

Electrical Information

Main Menu

- [Safety Start Module](#)
- [Electric Start Battery](#)
- [Fuses](#)
- [Relay](#)

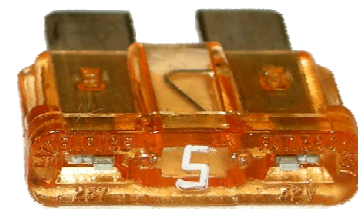
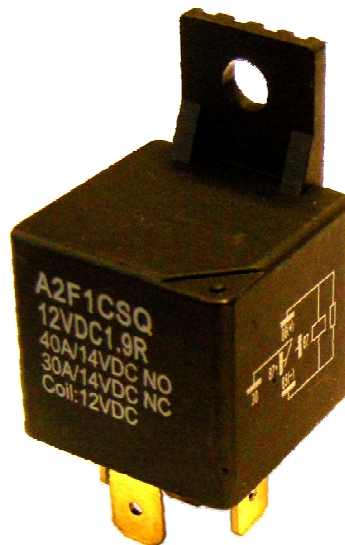
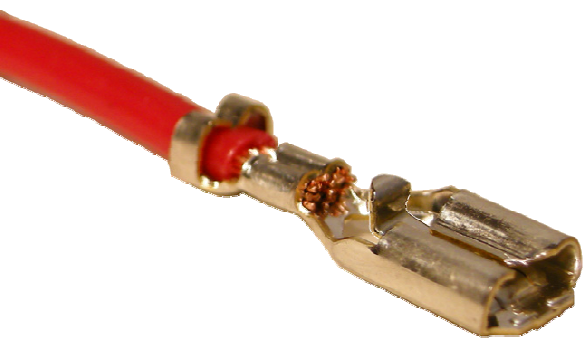
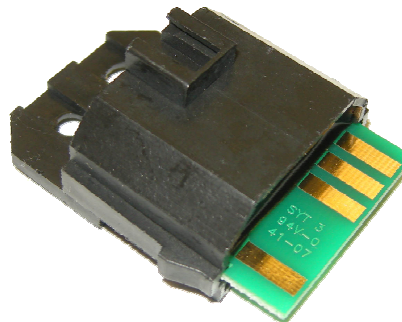

[PRIMARY MENU](#)

[LRV MENU](#)

Electrical Information

- There is a safety start module in the ignition system.
- The safety start module prevents the engine from starting unless the engagement clutch is in the 'OFF' position and the brake/clutch pedal is fully depressed.
- The engine still has the ability to turn over using the ignition switch or pull start cord but will not start until the conditions above are met.
- The safety start module is only active when starting the engine!

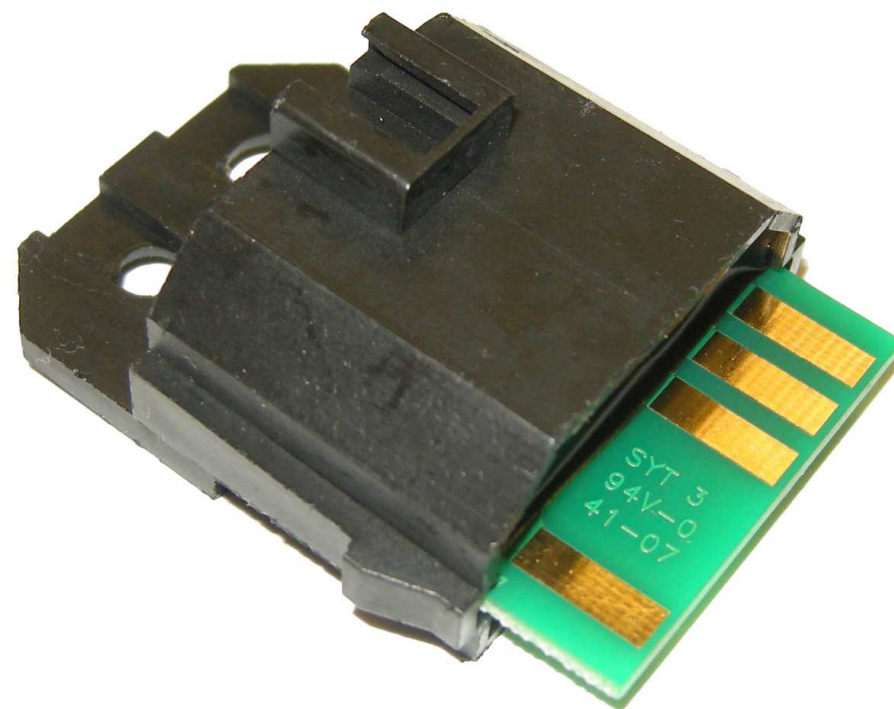

[RETURN TO
MAIN MENU](#)

Electrical Information

- We can use the electrical schematic to show the function of the module.

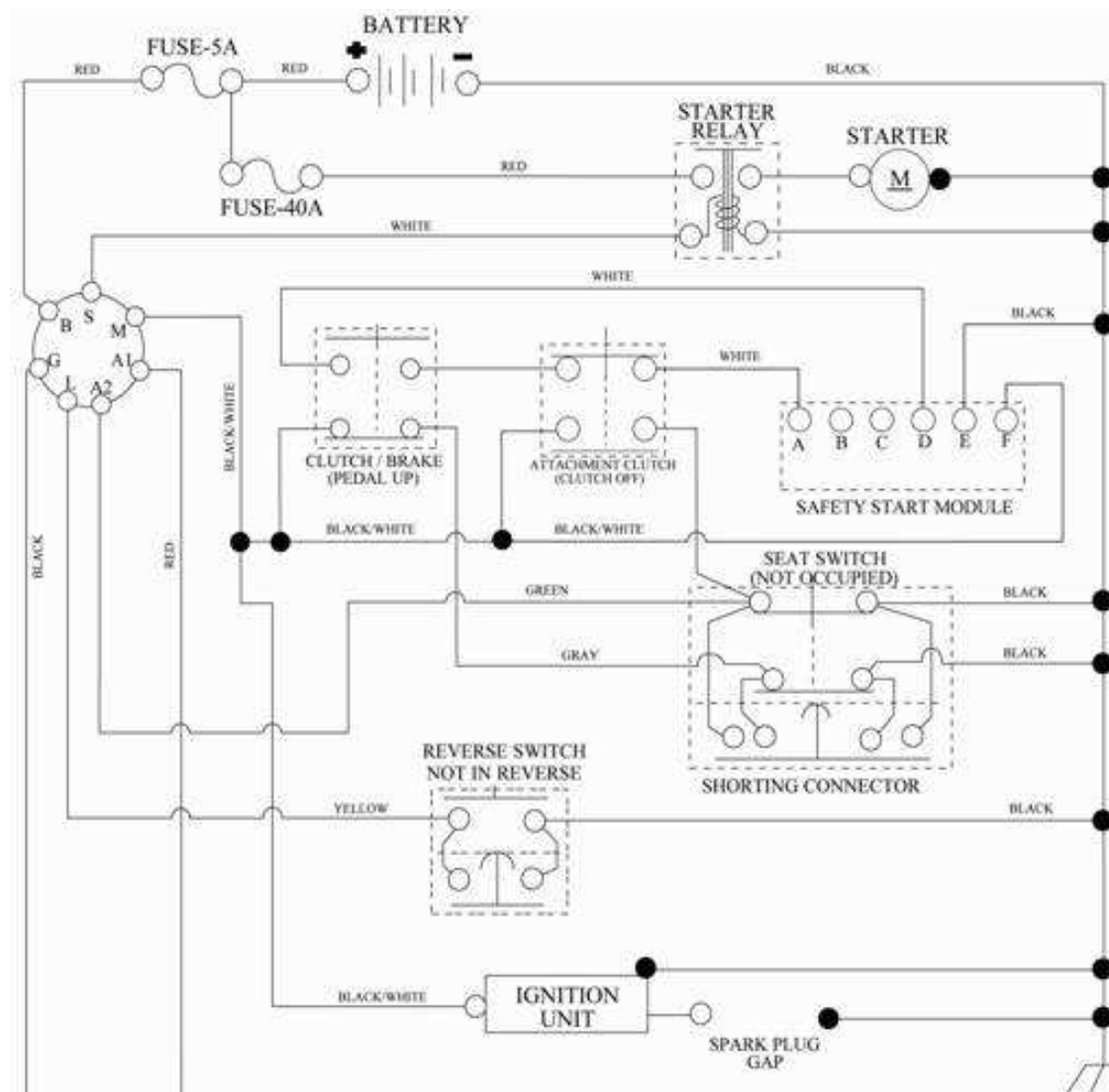

[RETURN TO
MAIN MENU](#)

Electrical Information

- This module is on the electrical harness so that the engine can not be started if either the clutch/brake pedal or the attachment clutch is in the engaged position.
- Note the two blue arrows. These are the interlock switches for the clutch/brake pedal and the attachment clutch.
- The clutch/brake interlock switch is 'open' because the drive system is engaged.
- Because one of the interlock switches is 'open', the module prevents the engine from starting by grounding the engine kill wire.

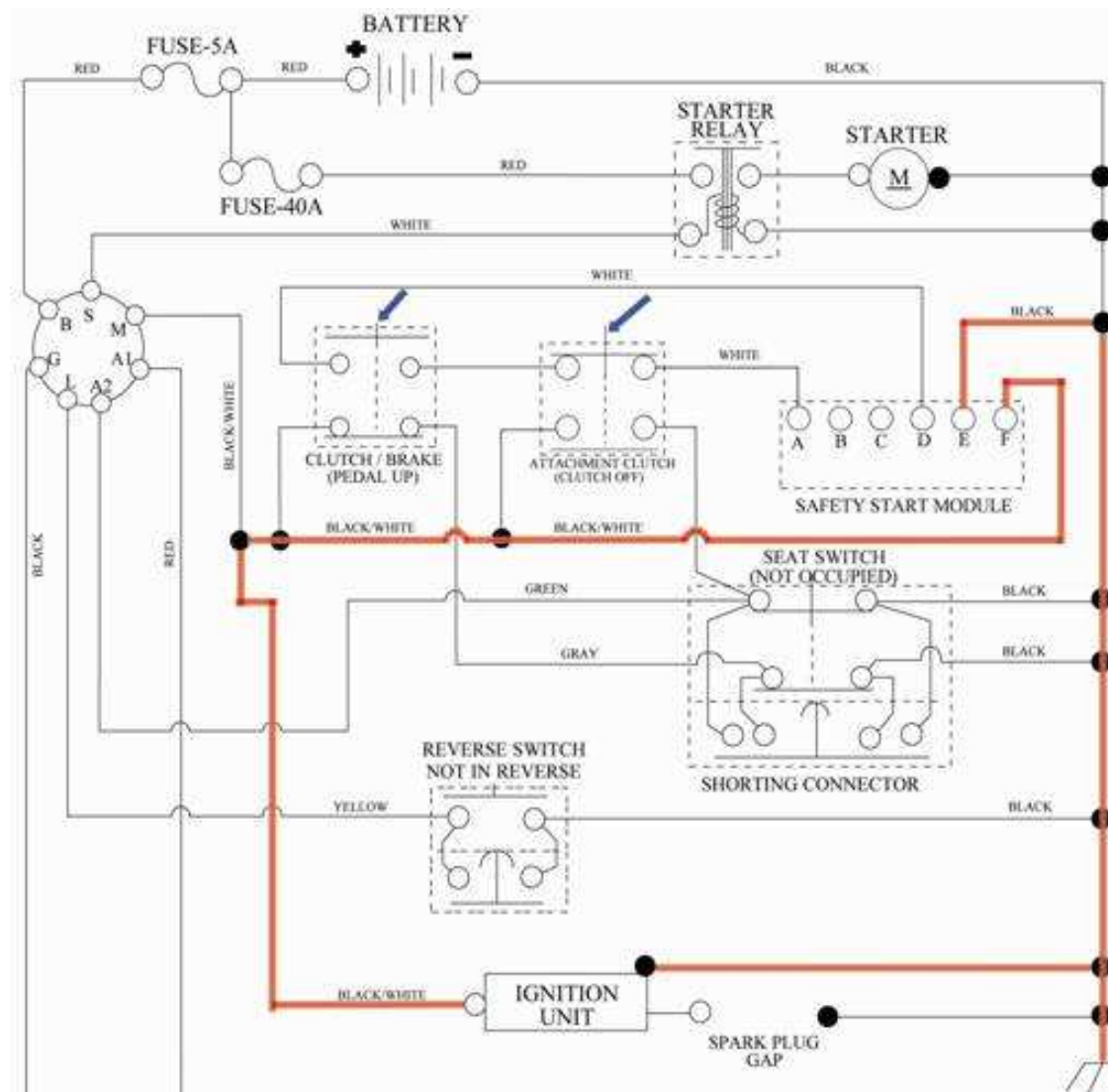

[RETURN TO
MAIN MENU](#)

Electrical Information

- When the ground drive and the attachment clutch are disengaged, the interlock switches are closed.
- This opens the 'ignition kill' switch in the module so that the engine can be started.
- Once the engine has started the module is no longer an active part of the system until the engine is shut off again.

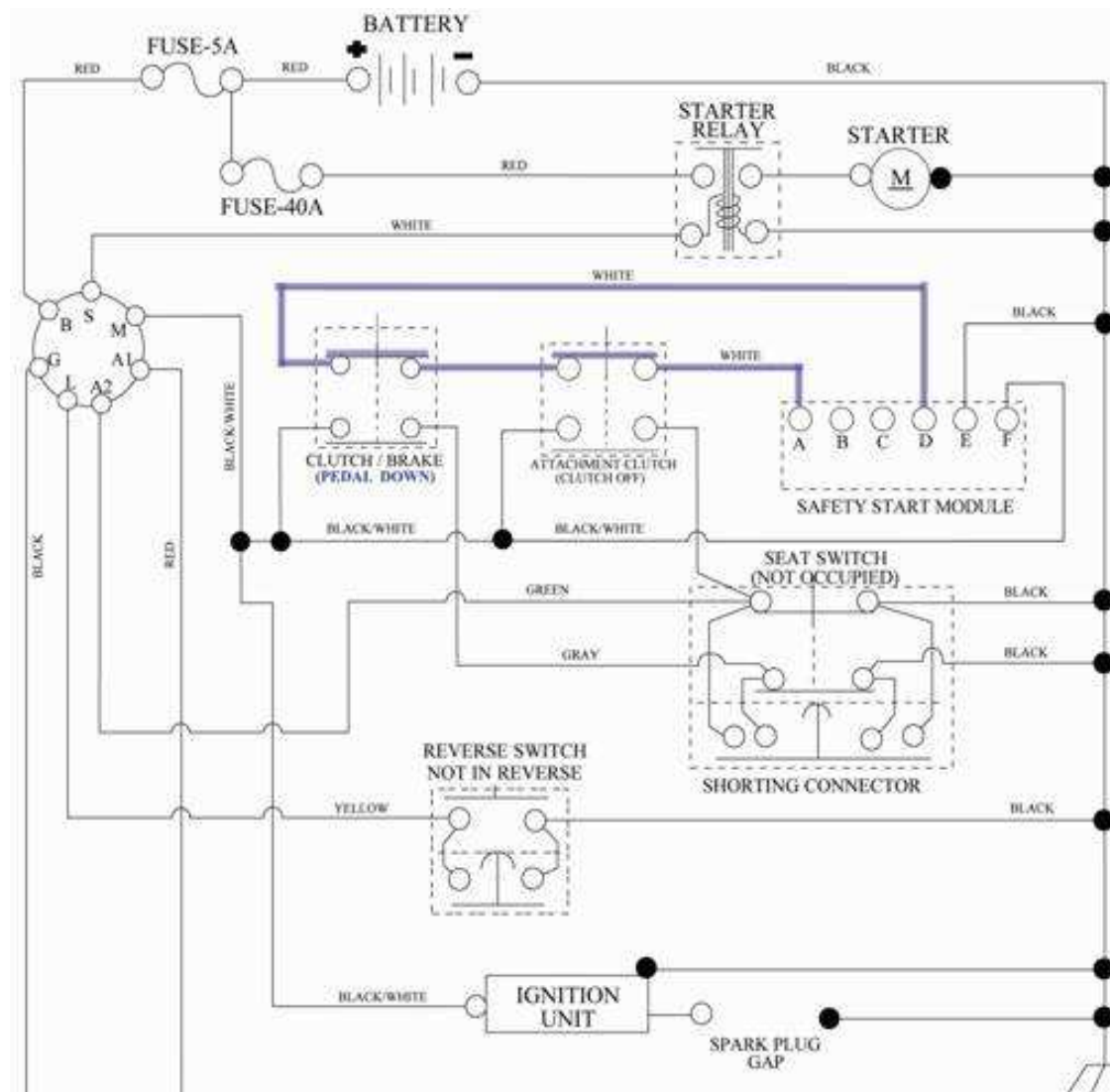

[RETURN TO
MAIN MENU](#)

Electrical Information



- The module is tied to the electrical harness with a plastic tie.

[RETURN TO
MAIN MENU](#)

Electrical Harness Note

- The end of the electrical harness is connected to the normally open ROS interlock switch on the transmission shift arm.
- The transmission shift arm and the rear carrier brace must be removed to access the ROS interlock switch or the end of the electrical harness.

SHIFT ARM

ROS INTERLOCK SWITCH

REAR CARRIER BRACE

[RETURN TO
MAIN MENU](#)

Electrical Harness Note

- Harness routing

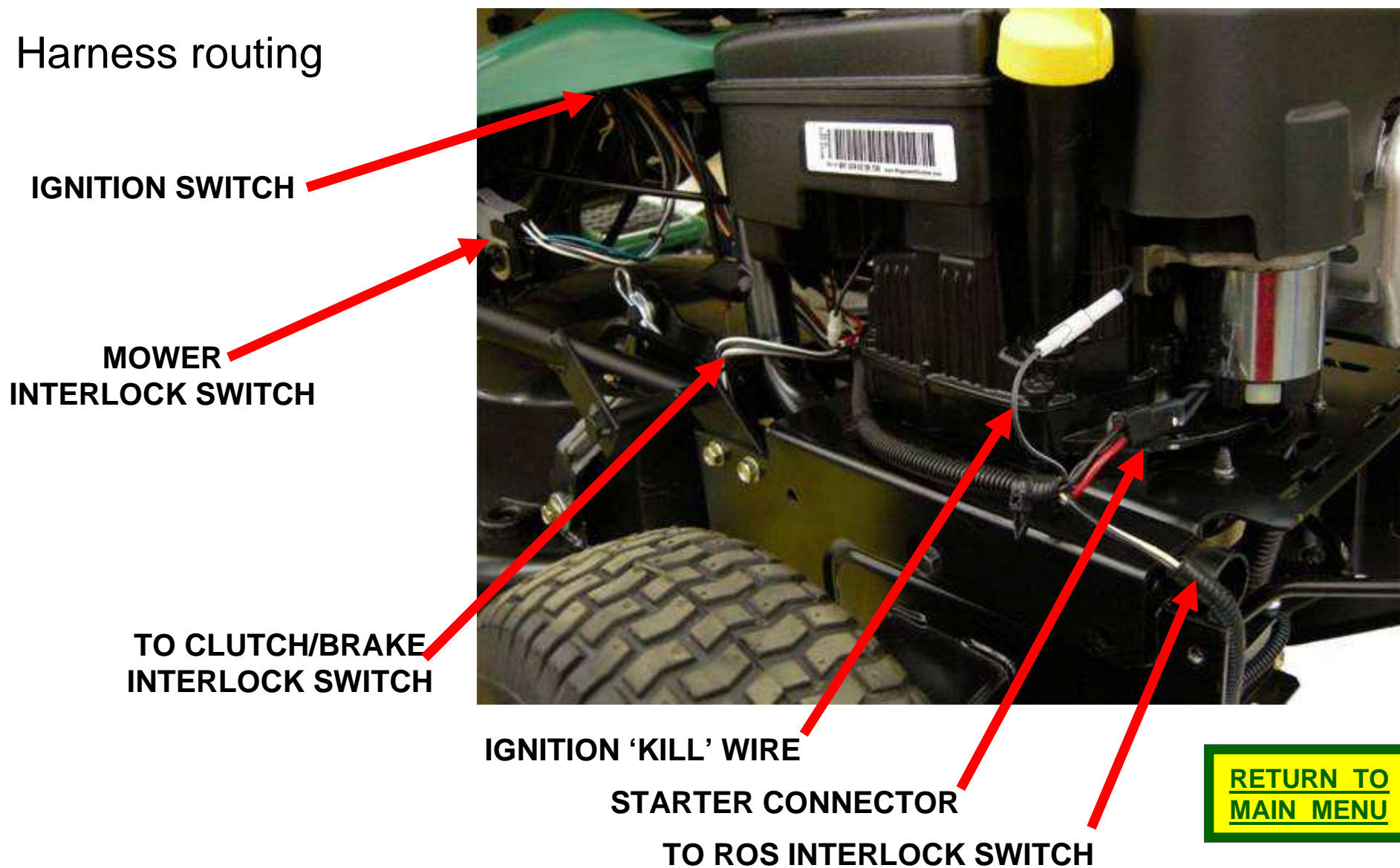

Electrical Information



- The LRV has both a recoil starter and an electric starter for the engine.
- This battery is used for the electric starter.

[RETURN TO
MAIN MENU](#)

Electrical Information

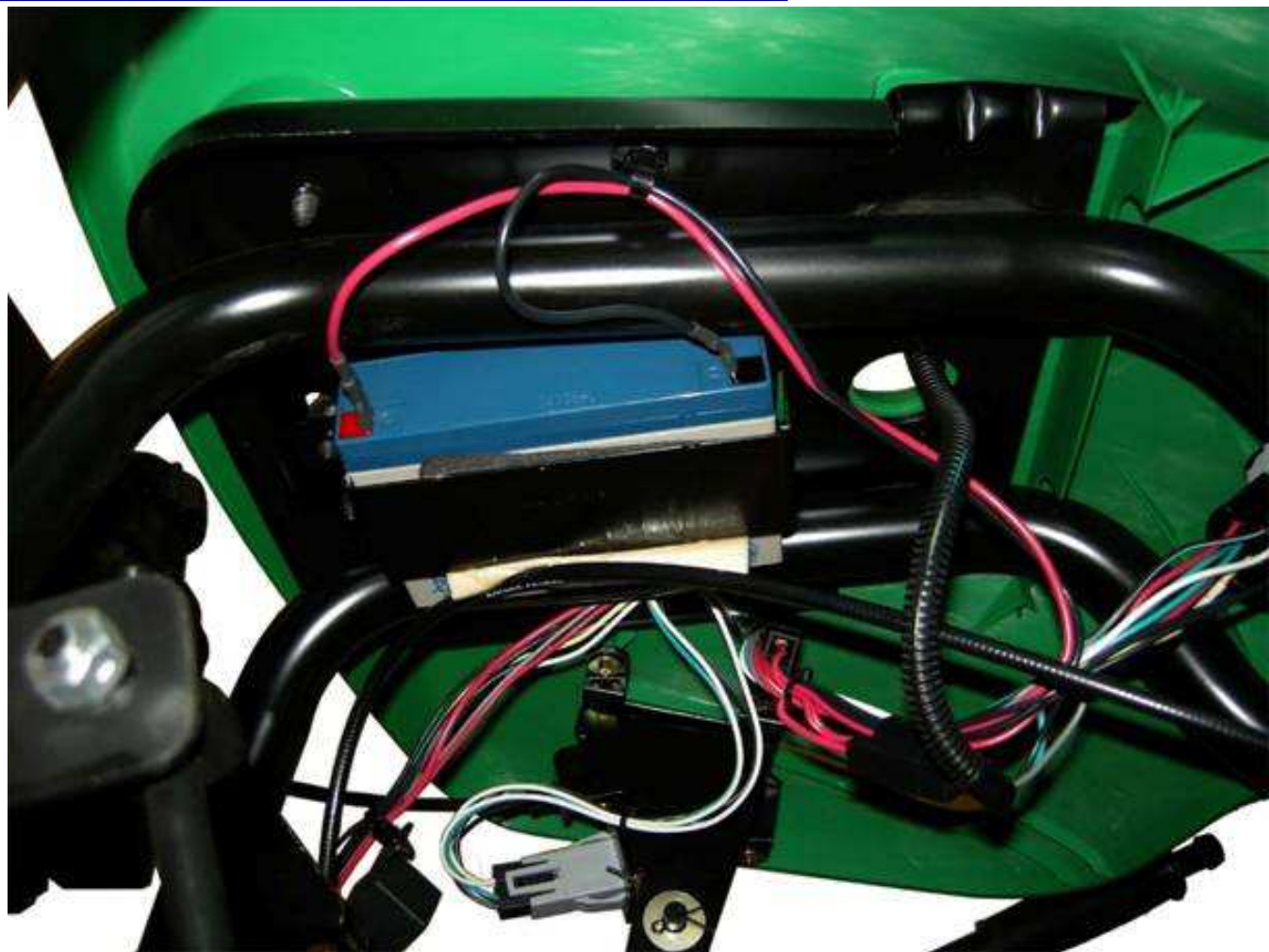

- The battery is located under the fender.

[RETURN TO
MAIN MENU](#)

Electrical Information

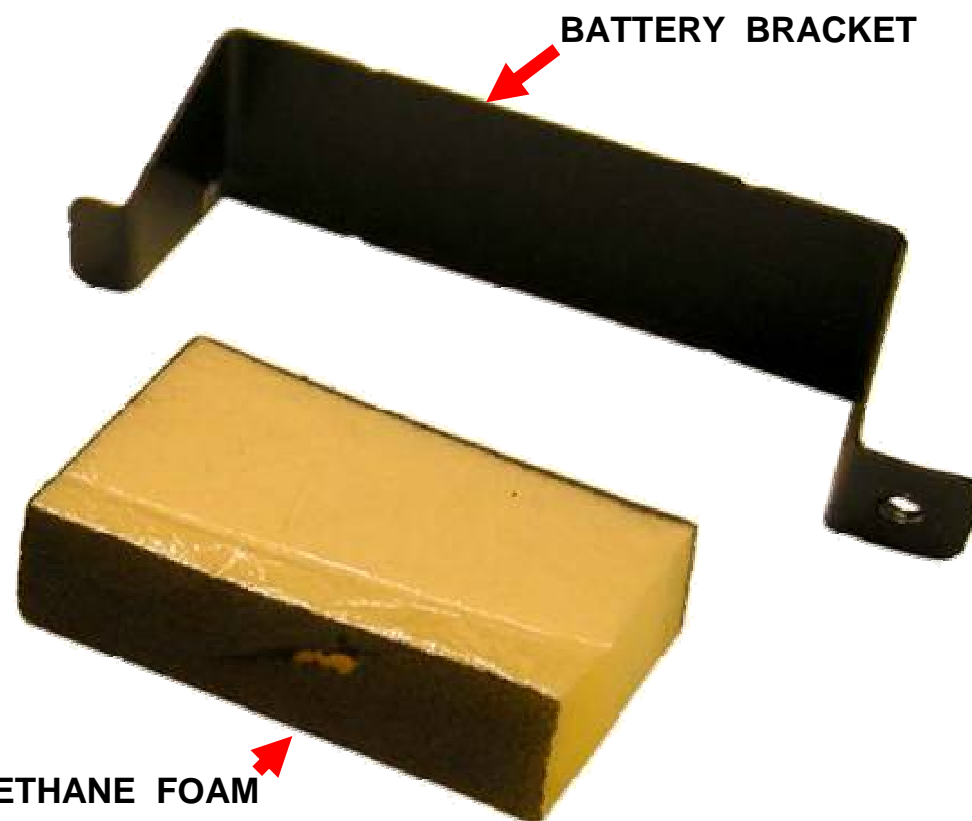

- There is a battery bracket used to mount the battery in position.
- The polyurethane foam is required to dampen vibration to the battery.

[RETURN TO
MAIN MENU](#)

Electrical Information

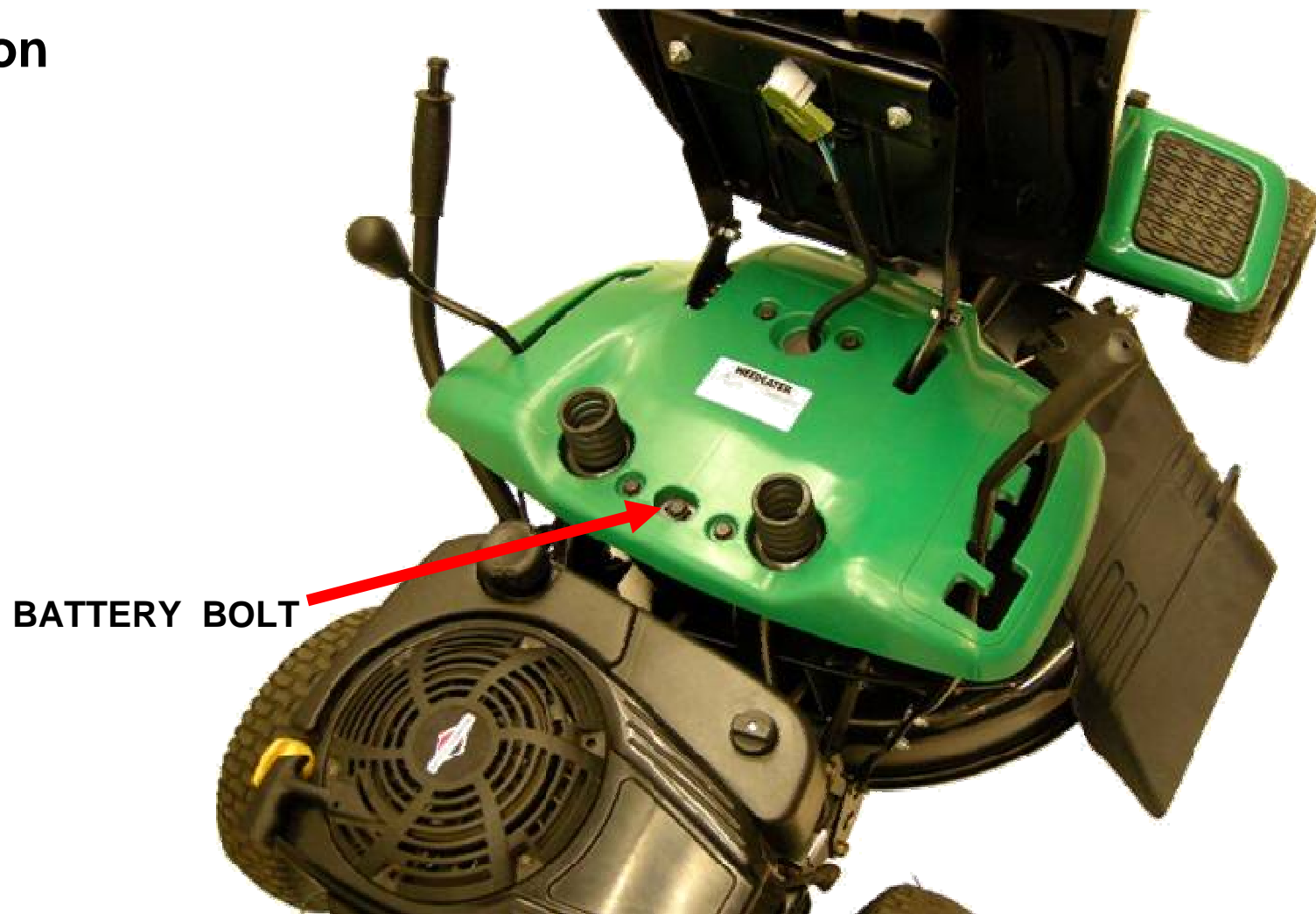

- The bolt securing the battery bracket is found on top of the fender.

[RETURN TO
MAIN MENU](#)

Electrical Information

BATTERY # 423264



- While removing or installing the battery, the mandrel cover is a convenient place to put the battery.
- For 2010, there is not a provision for external charging of the battery, without removing it from the LRV.

[RETURN TO
MAIN MENU](#)

Electrical Information

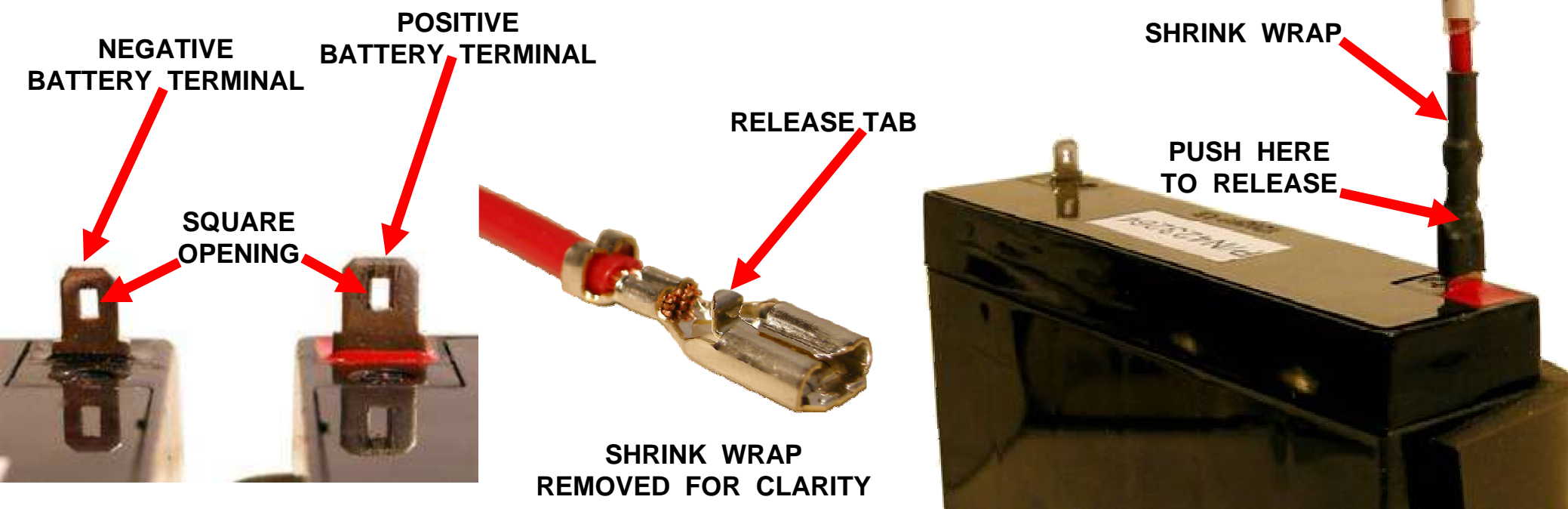

- Technicians will have difficulty removing the improved harness terminal receptacles from the battery terminals if they are not aware there is a tab to depress to release the terminal lock.
- Pinch with fingers to release.
- If the improved terminal receptacle is forced off the battery terminal, the locking feature will still function with less locking engagement.

[RETURN TO
MAIN MENU](#)

Electrical Information

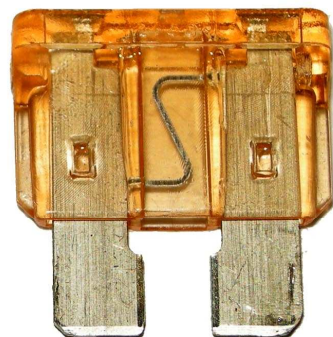

433330 5 AMP FUSE

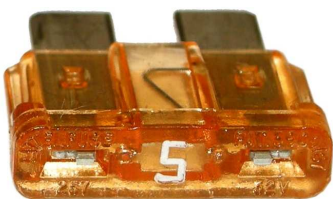

425937 40 AMP FUSE

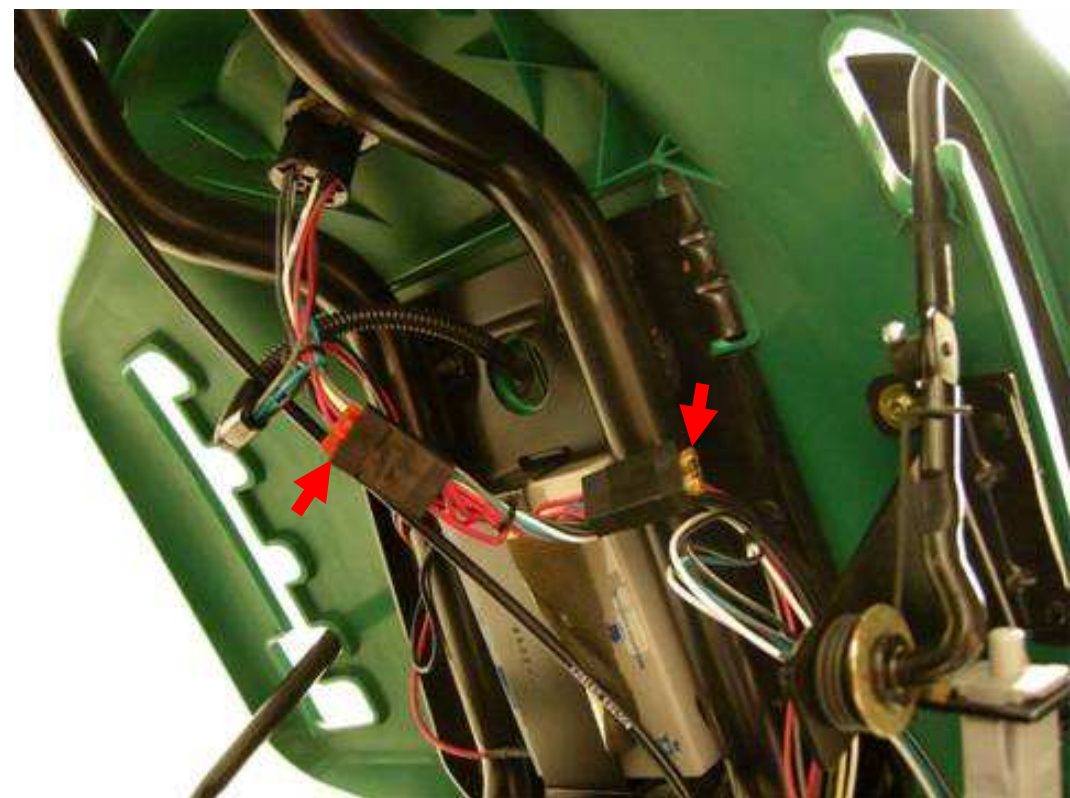

- There is a 40 AMP fuse in the start circuit.
- A 5 AMP fuse is in the charging circuit.

[RETURN TO
MAIN MENU](#)

Electrical Information

- The LRV will use a 40 AMP relay instead of a solenoid in the electric start circuit.

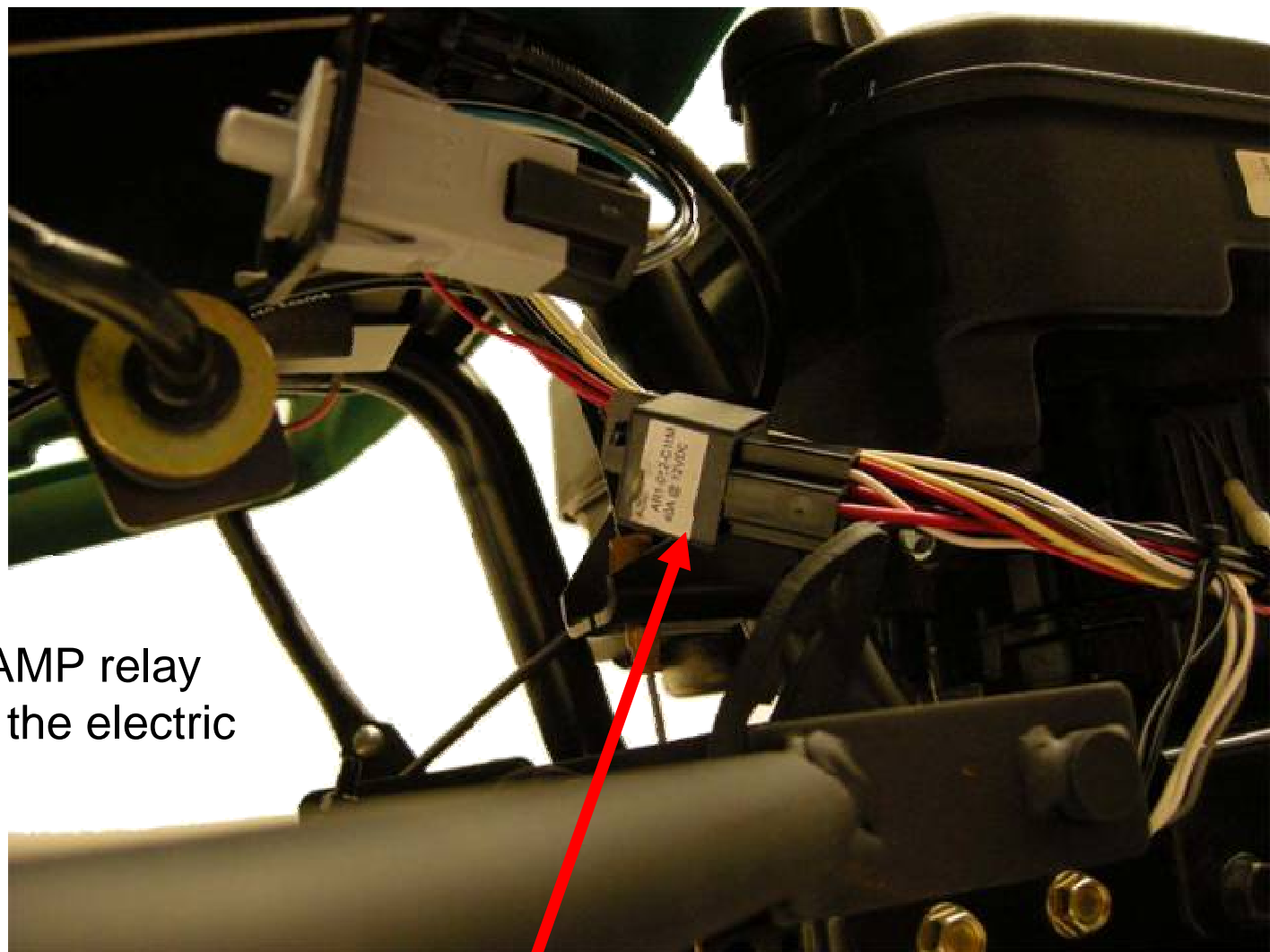

431542 RELAY – 40 AMP

[RETURN TO
MAIN MENU](#)

Electrical Information

431542 RELAY – 40 AMP

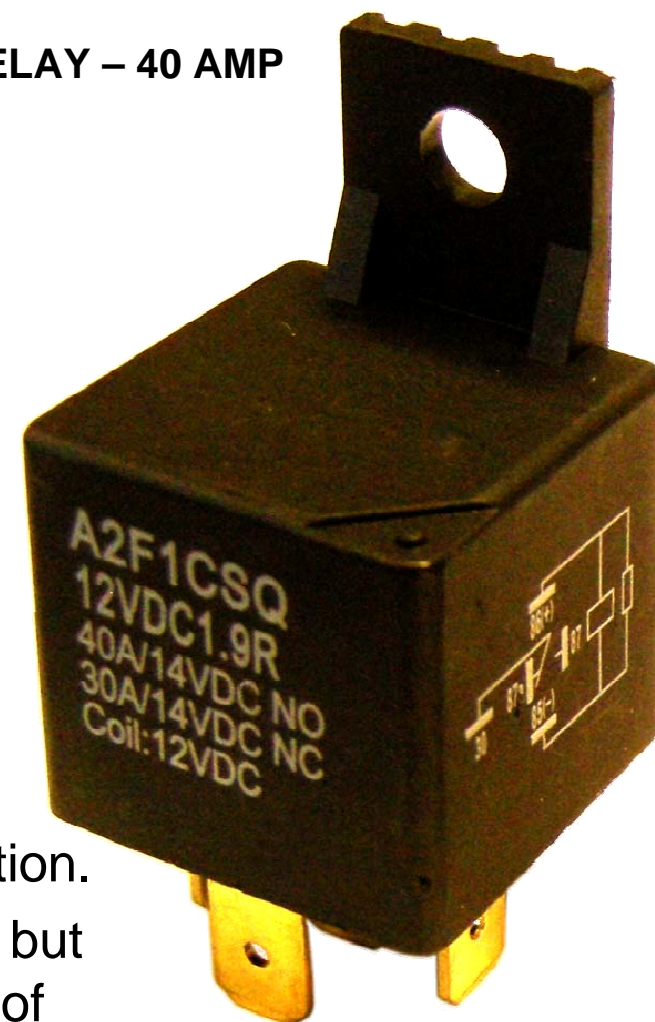

- Use only the 40 AMP relay specified for this application.
- Many relays look identical and attach the same way but are not designed to handle the high starter currents of the engine.
- An undersized relay can lead to contact welding preventing the starter motor from disengaging.

[RETURN TO
MAIN MENU](#)

Electrical Information

The End

PRIMARY MENU

LRV MENU

RETURN TO
MAIN MENU