

# REPAIR PARTS SNOW THROWER -- MODEL NUMBER PP10527ES (96192002001)

## AUGER HOUSING / IMPELLER ASSEMBLY

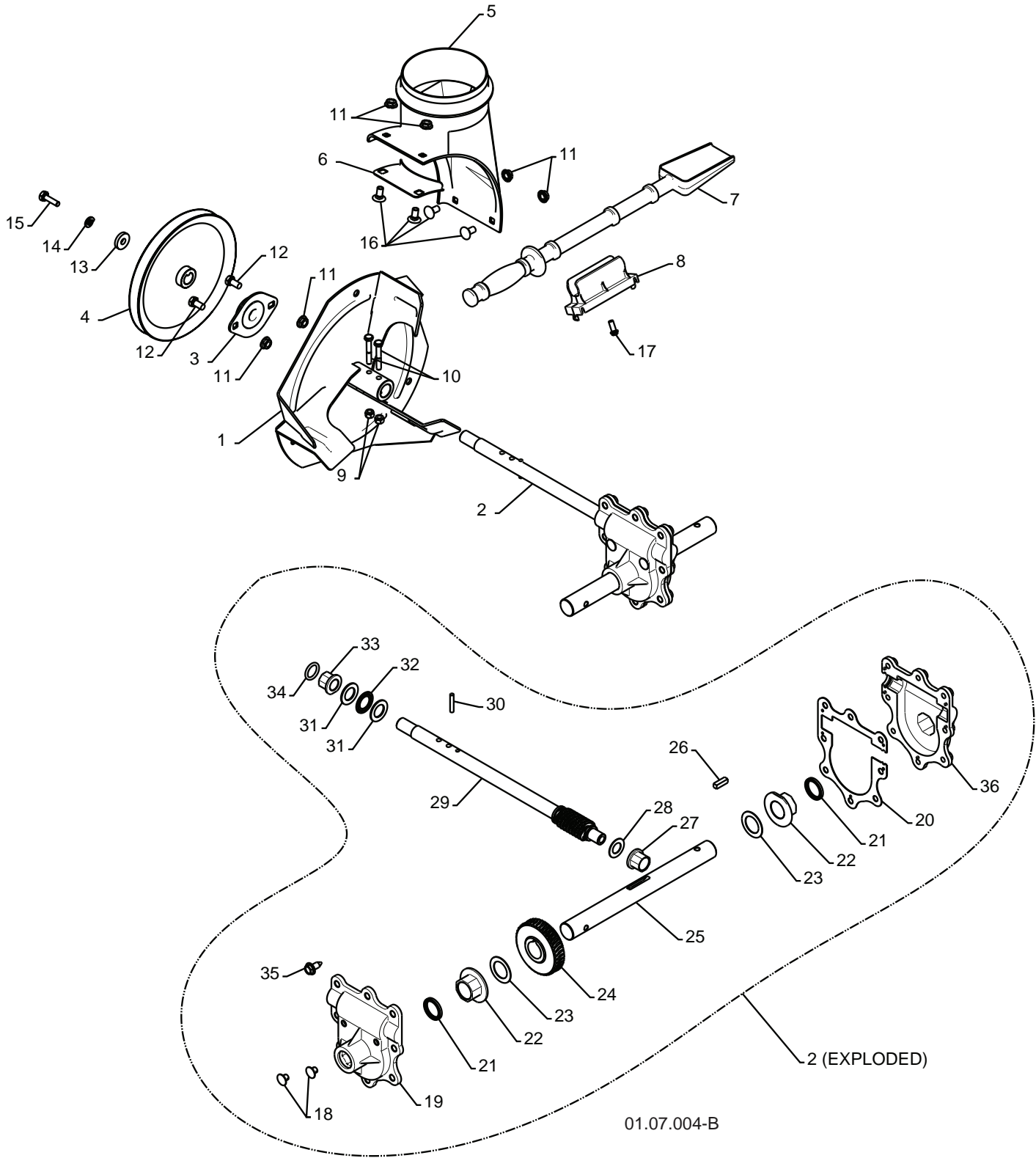

01.07.004-B

**NOTE:** All component dimensions given in U.S. inches. 1 inch = 25.4 mm  
**IMPORTANT:** Use only Original Equipment Manufacturer (O.E.M.) replacement parts.  
 Failure to do so could be hazardous, damage your snow thrower and void your warranty.

# REPAIR PARTS SNOW THROWER -- MODEL NUMBER PP10527ES (96192002001)

## AUGER HOUSING / IMPELLER ASSEMBLY

KEY NO.	PART NO.	DESCRIPTION
1	175321X479	IMPELLER
2	196710	GEARBOX ASSEMBLY
3	188909	BEARING
4	191079	IMPELLER PULLEY
5	175322	DISCHARGE BASE
6	178675X008	CORNER BRACKET
7	192199	CLEAN OUT TOOL
8	405400	TOOL CLIP
9	73800400	NUT 1/4-20
10	74780426	SCREW 1/4-20 X .625
11	155377	NUT 5/16-18
12	163183	SCREW 5/16-18 X .625
13	19111507	WASHER
14	10040500	LOCKWASHER 5/16
15	74940516	SCREW 5/16-18 X 1.00
16	180355	CARRIAGE BOLT
17	194189	SCREW 13-16 X .625
18	407760	PLUG
19	407761	GEARBOX COVER RH
20	407766	GASKET
21	407770	SEAL
22	407762	BEARING
23	174697	THRUST WASHER 1.00
24	407763	WORM GEAR
25	407764	AUGER SHAFT
26	189282	SQUARE KEY
27	407758	BEARING
28	174683	THRUST WASHER
29	407757	IMPELLER SHAFT
30	7836M	ROLL PIN
31	174681	THRUST WASHER
32	174684	THRUST BEARING
33	407769	BEARING
34	407768	O-RING
35	407767	SCREW 5/16-18 X .750
36	407765	GEARBOX COVER LH

**NOTE:** All component dimensions given in U.S. inches. 1 inch = 25.4 mm  
**IMPORTANT:** Use only Original Equipment Manufacturer (O.E.M.) replacement parts.  
 Failure to do so could be hazardous, damage your snow thrower and void your warranty.

**REPAIR PARTS SNOW THROWER -- MODEL NUMBER PP10527ES (96192002001)**  
**AUGER HOUSING / IMPELLER ASSEMBLY**

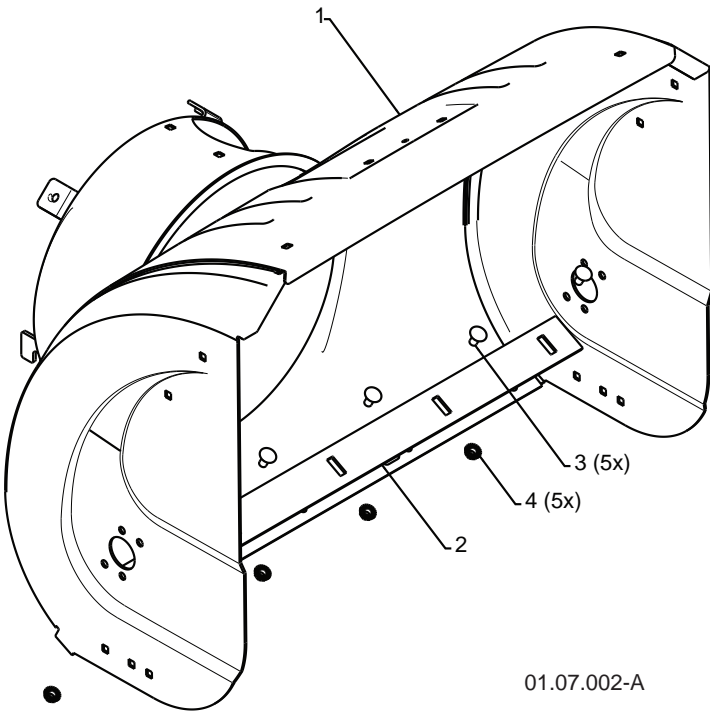

KEY NO.	PART NO.	DESCRIPTION
1	404929X428	AUGER HOUSING 27
2	404932X479	SCRAPER BAR
3	72270505	CARRIAGE BOLT 5/16-18 X .625
4	155377	NUT 5/16-18

01.07.002-A

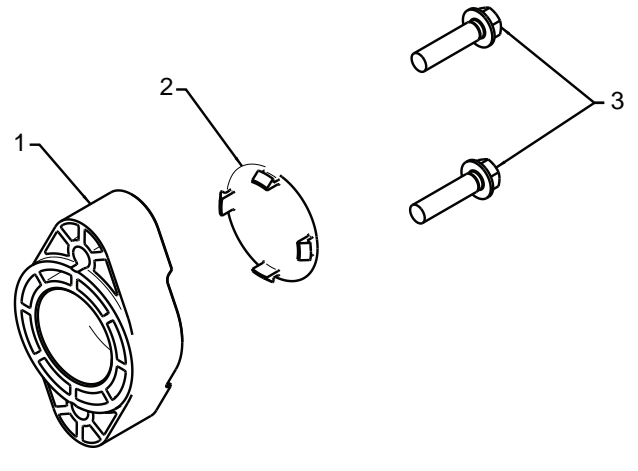

KEY NO.	PART NO.	DESCRIPTION
1	420478	AUGER BEARING
2	411939	BEARING PLUG
3	179582	SCREW 5/16-18 X 1.00

01.07.024-B

**NOTE:** All component dimensions given in U.S. inches. 1 inch = 25.4 mm  
**IMPORTANT:** Use only Original Equipment Manufacturer (O.E.M.) replacement parts. Failure to do so could be hazardous, damage your snow thrower and void your warranty.

# REPAIR PARTS SNOW THROWER -- MODEL NUMBER PP10527ES (96192002001)

## AUGER HOUSING / IMPELLER ASSEMBLY

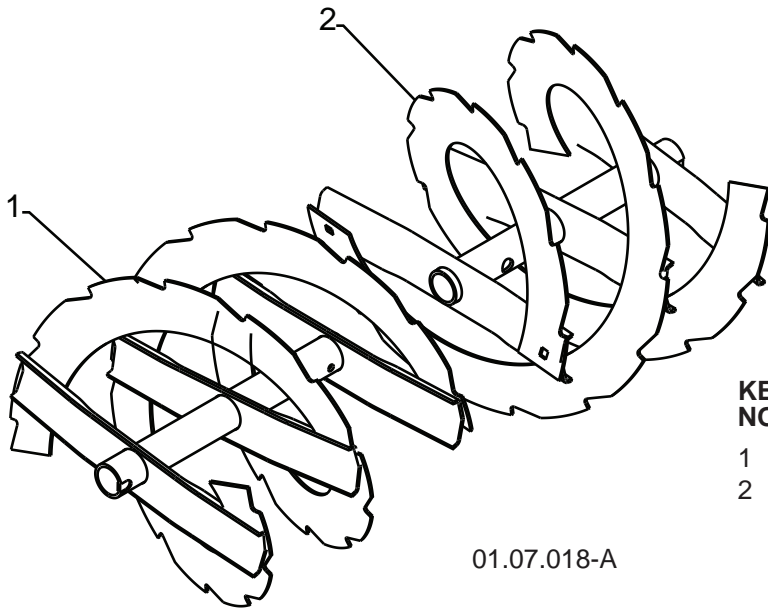

KEY NO.	PART NO.	DESCRIPTION
1	420495X479	AUGER 27 LH
2	420496X479	AUGER 27 RH

01.07.018-A

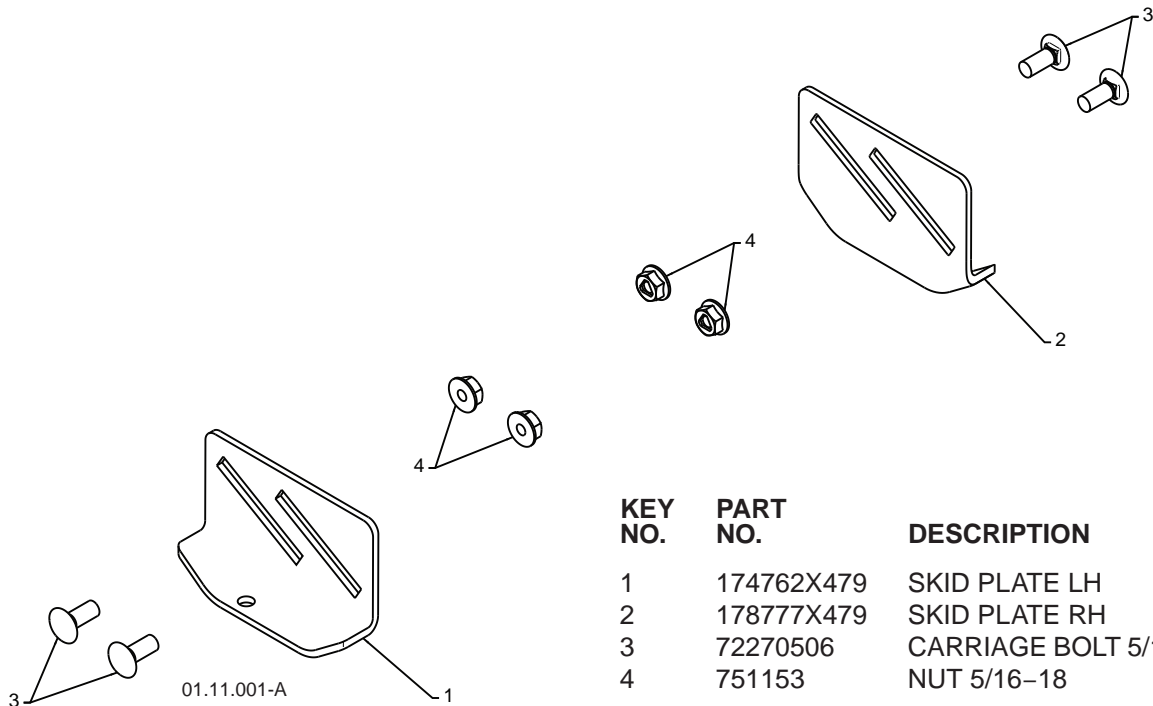

KEY NO.	PART NO.	DESCRIPTION
1	174762X479	SKID PLATE LH
2	178777X479	SKID PLATE RH
3	72270506	CARRIAGE BOLT 5/16-18 X .75
4	751153	NUT 5/16-18

01.11.001-A

**NOTE:** All component dimensions given in U.S. inches. 1 inch = 25.4 mm  
**IMPORTANT:** Use only Original Equipment Manufacturer (O.E.M.) replacement parts.  
 Failure to do so could be hazardous, damage your snow thrower and void your warranty.

# REPAIR PARTS SNOW THROWER -- MODEL NUMBER PP10527ES (96192002001)

## CONTROL PANEL / CHUTE

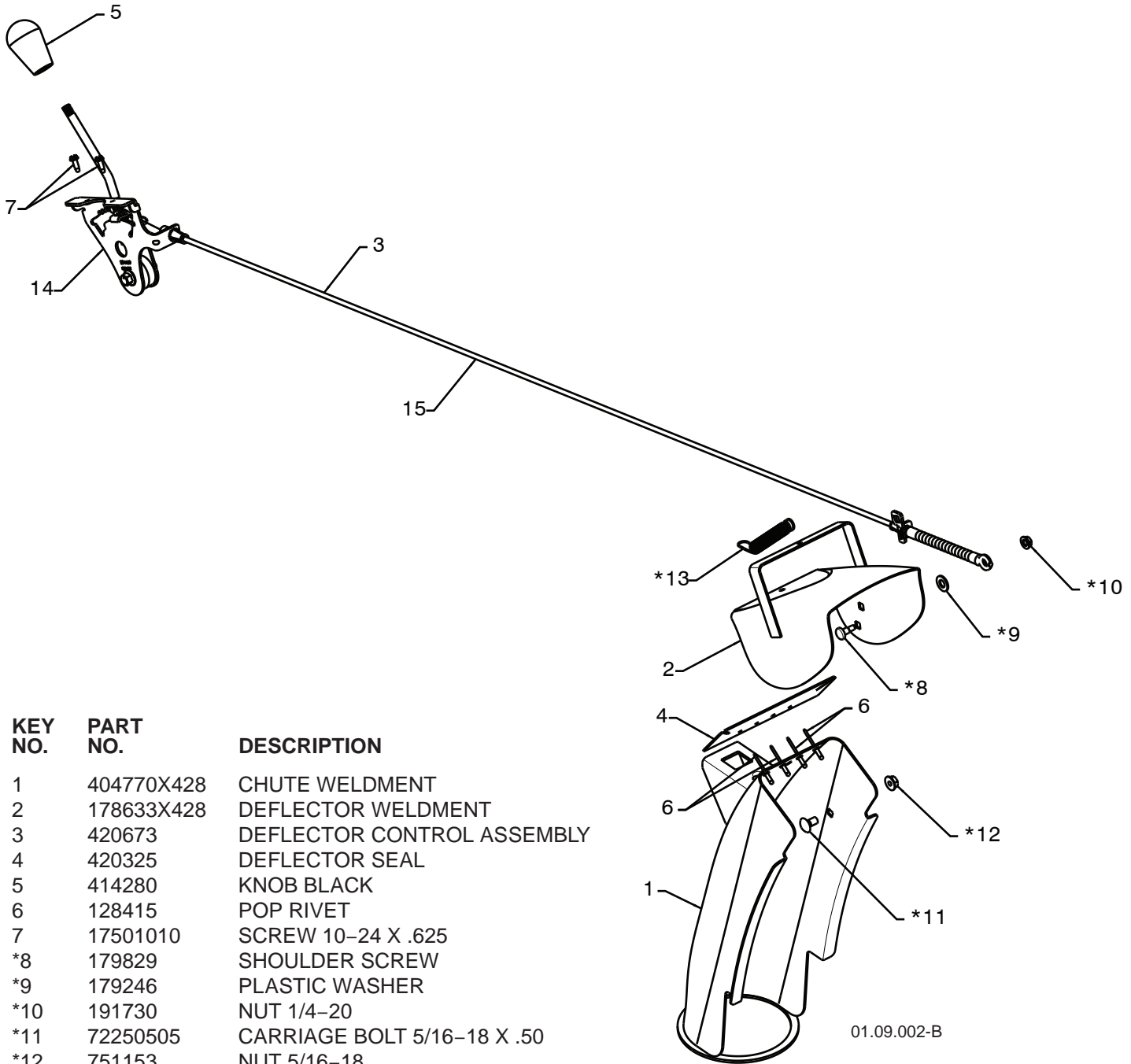

KEY NO.	PART NO.	DESCRIPTION
1	404770X428	CHUTE WELDMENT
2	178633X428	DEFLECTOR WELDMENT
3	420673	DEFLECTOR CONTROL ASSEMBLY
4	420325	DEFLECTOR SEAL
5	414280	KNOB BLACK
6	128415	POP RIVET
7	17501010	SCREW 10-24 X .625
*8	179829	SHOULDER SCREW
*9	179246	PLASTIC WASHER
*10	191730	NUT 1/4-20
*11	72250505	CARRIAGE BOLT 5/16-18 X .50
*12	751153	NUT 5/16-18
*13	184505	DEFLECTOR SPRING
14	420679	(SERVICE PART) DEFLECTOR CONTROL HEAD
15	420672	(SERVICE PART) DEFLECTOR CONTROL CABLE

### NOTE:

1. ALL ITEMS INDICATED WITH AN \* ARE PROVIDED IN THE BAG OF ITEMS SHIPPED LOOSE WITH PRODUCT.
2. ITEMS 14 AND 15 ARE SERVICE PART NUMBERS TO ALLOW PURCHASE OF INDIVIDUAL ITEMS IF NECESSARY.

**NOTE:** All component dimensions given in U.S. inches. 1 inch = 25.4 mm  
**IMPORTANT:** Use only Original Equipment Manufacturer (O.E.M.) replacement parts.  
 Failure to do so could be hazardous, damage your snow thrower and void your warranty.

# REPAIR PARTS SNOW THROWER -- MODEL NUMBER PP10527ES (96192002001)

## CONTROL PANEL / CHUTE

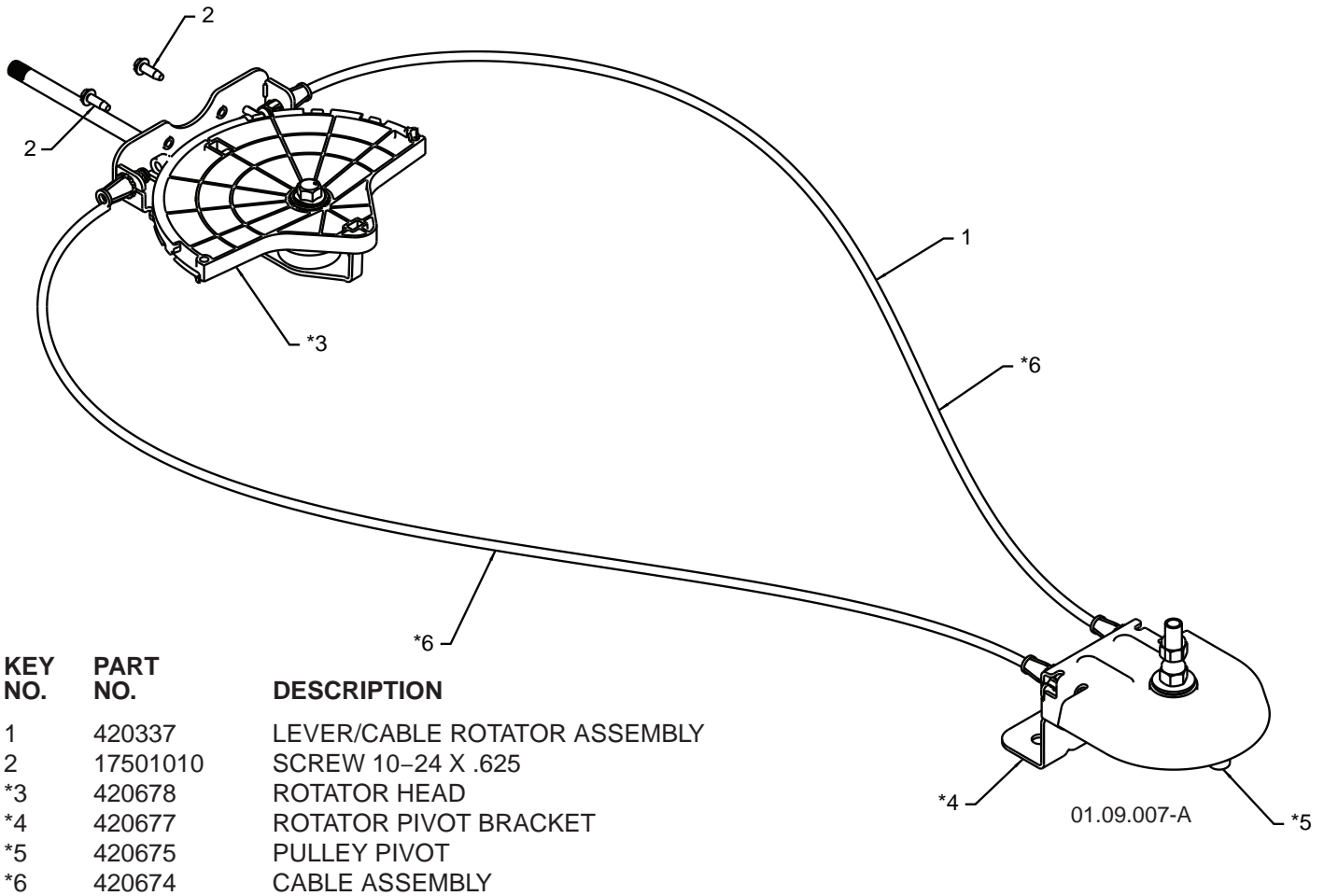

KEY NO.	PART NO.	DESCRIPTION
1	420337	LEVER/CABLE ROTATOR ASSEMBLY
2	17501010	SCREW 10-24 X .625
*3	420678	ROTATOR HEAD
*4	420677	ROTATOR PIVOT BRACKET
*5	420675	PULLEY PIVOT
*6	420674	CABLE ASSEMBLY

**NOTES:**

1. ITEMS INDICATED WITH AN \* ARE LISTED AS REFERENCE FOR SERVICE PARTS ONLY.

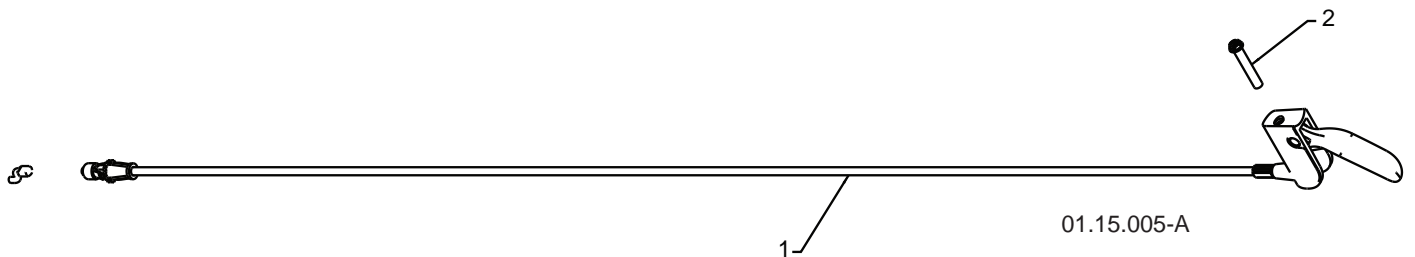

KEY NO.	PART NO.	DESCRIPTION
1	188303	STEER CABLE
2	74041024	SCREW 10-24 X 1.50

**NOTE:** All component dimensions given in U.S. inches. 1 inch = 25.4 mm  
**IMPORTANT:** Use only Original Equipment Manufacturer (O.E.M.) replacement parts.  
 Failure to do so could be hazardous, damage your snow thrower and void your warranty.

# REPAIR PARTS SNOW THROWER -- MODEL NUMBER PP10527ES (96192002001) HANDLES

KEY NO.	PART NO.	DESCRIPTION
1	419798X479	LOOP HANDLE LH
2	419799X479	LOOP HANDLE RH
3	74780524	SCREW 5/16-18 X 1.50
4	74780528	SCREW 5/16-18 X 1.75
5	751153	NUT 5/16-18

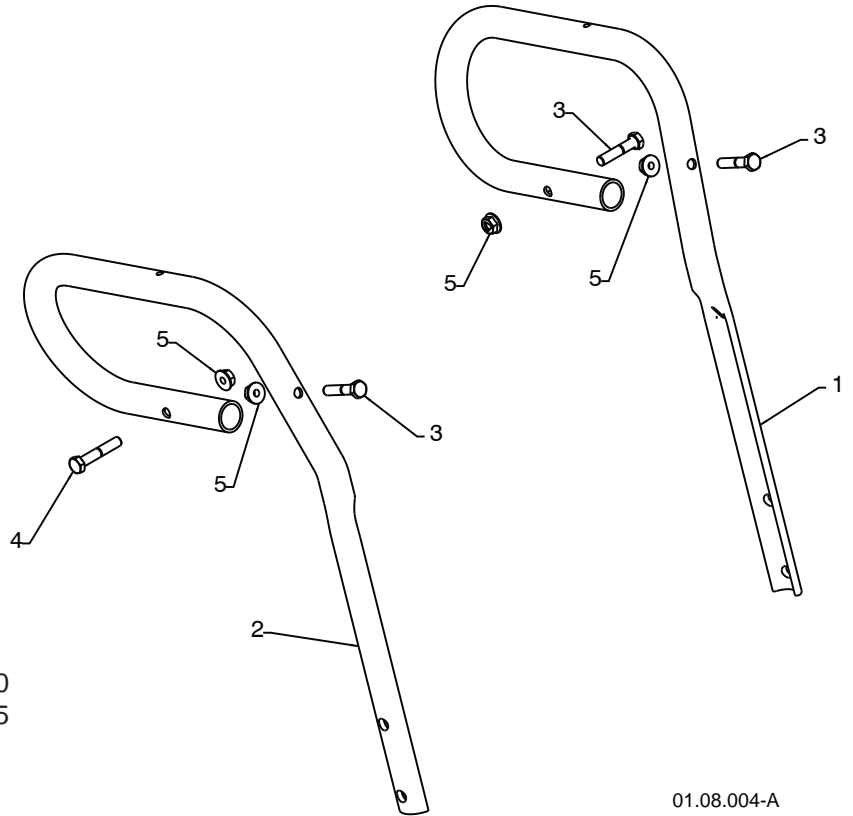

01.08.004-A

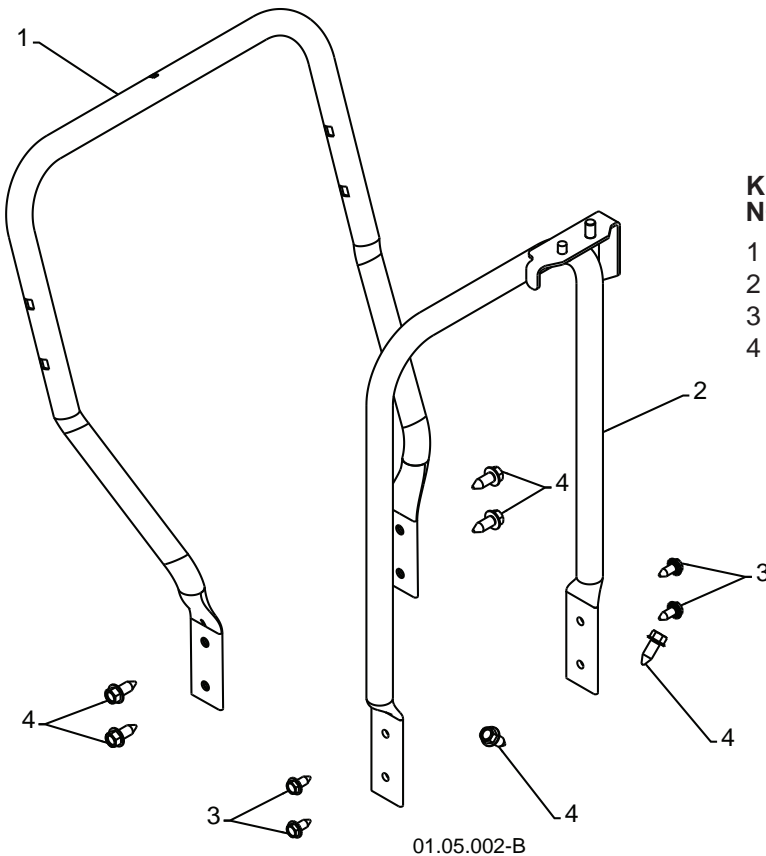

KEY NO.	PART NO.	DESCRIPTION
1	419797X479	LOWER HANDLE
2	405784X479	PIVOT SUPPORT WELDMENT
3	150078	SCREW 5/16-18 X .750
4	17000616	SCREW 3/8-16 X 1.00

01.05.002-B

**NOTE:** All component dimensions given in U.S. inches. 1 inch = 25.4 mm  
**IMPORTANT:** Use only Original Equipment Manufacturer (O.E.M.) replacement parts.  
 Failure to do so could be hazardous, damage your snow thrower and void your warranty.

# REPAIR PARTS SNOW THROWER -- MODEL NUMBER PP10527ES (96192002001) HANDLES

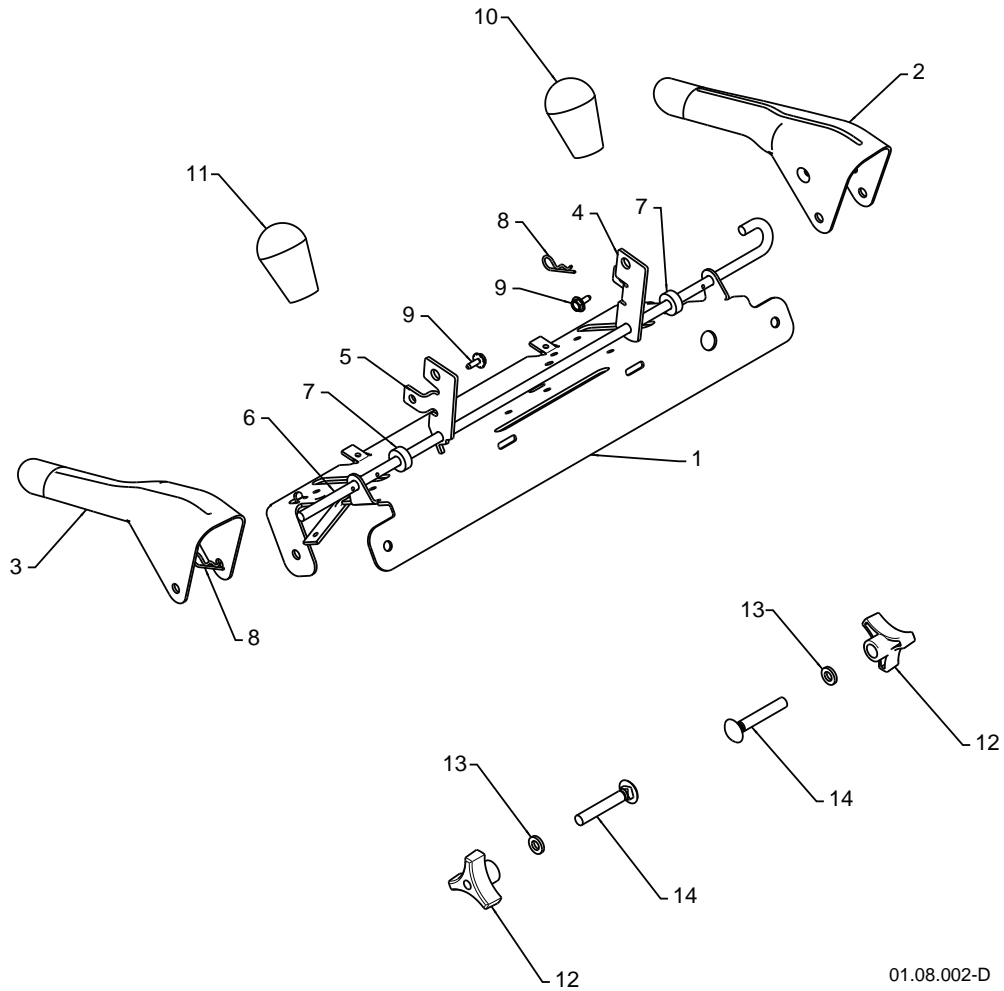

01.08.002-D

KEY NO.	PART NO.	DESCRIPTION
1	412683X479	CONTROL PANEL
2	412681X479	CONTROL LEVER LH
3	412682X479	CONTROL LEVER RH
4	412679X008	TRACTION ROD ARM
5	420889X008	IMPELLER ROD ARM
6	412677	INTERLOCK ROD
7	412680	SPACER
8	169675	RETAINER
9	17060408	SCREW 1/4-20 X .50
10	414280	KNOB BLACK
11	414281	KNOB RED
12	178899	HANDLE KNOB
13	19131316	WASHER 3/8
14	72120618	CARRIAGE BOLT 3/8-16 X 2.25

**NOTE:** All component dimensions given in U.S. inches. 1 inch = 25.4 mm  
**IMPORTANT:** Use only Original Equipment Manufacturer (O.E.M.) replacement parts.  
 Failure to do so could be hazardous, damage your snow thrower and void your warranty.



# REPAIR PARTS SNOW THROWER -- MODEL NUMBER PP10527ES (96192002001)

## HANDLES

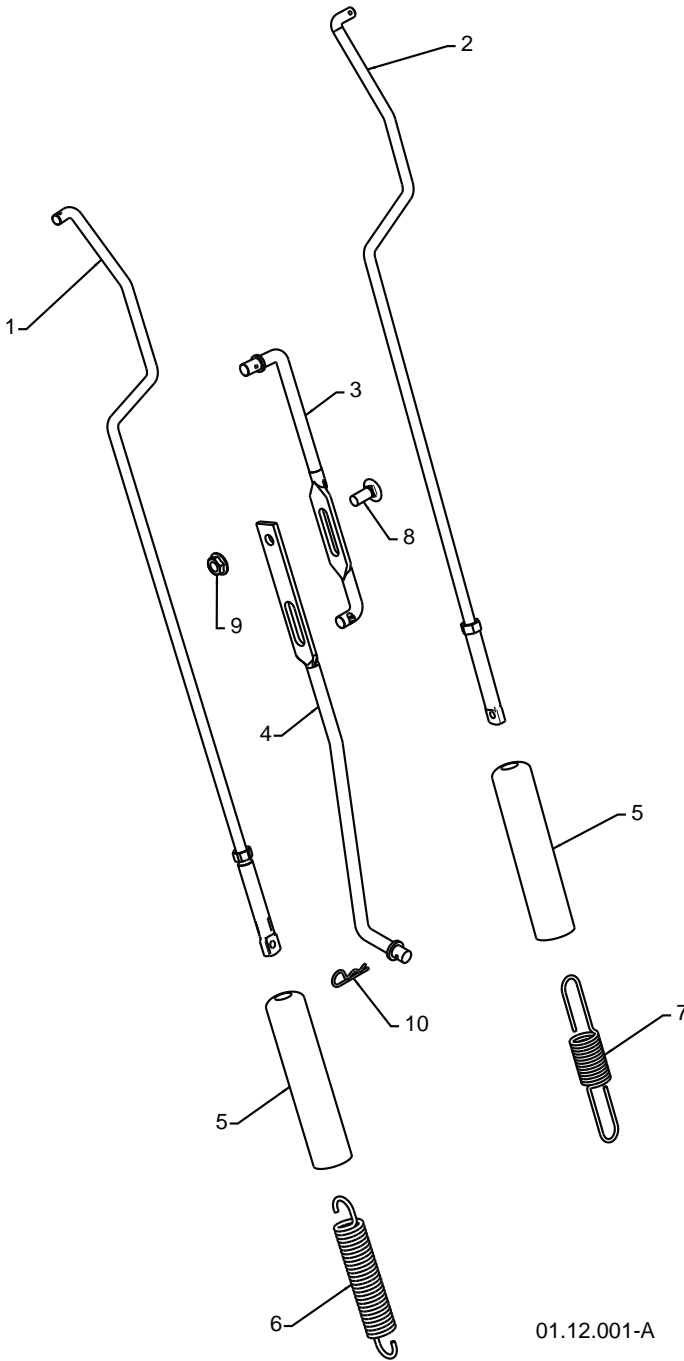

KEY NO.	PART NO.	DESCRIPTION
1	180480	IMPELLER ROD ASSEMBLY
2	405740	TRACTION ROD ASSEMBLY
3	180445	SHIFTER ROD TOP
4	187716	SHIFTER ROD BOTTOM
5	180447	SPRING SLEEVE
6	178669	IMPELLER SPRING
7	180926	TRACTION SPRING
8	72270506	CARRIAGE BOLT 5/16-18 X .75
9	155377	NUT 5/16-18
10	169675	RETAINER

01.12.001-A

**NOTE:** All component dimensions given in U.S. inches. 1 inch = 25.4 mm  
**IMPORTANT:** Use only Original Equipment Manufacturer (O.E.M.) replacement parts.  
 Failure to do so could be hazardous, damage your snow thrower and void your warranty.

# REPAIR PARTS SNOW THROWER -- MODEL NUMBER PP10527ES (96192002001) HANDLES

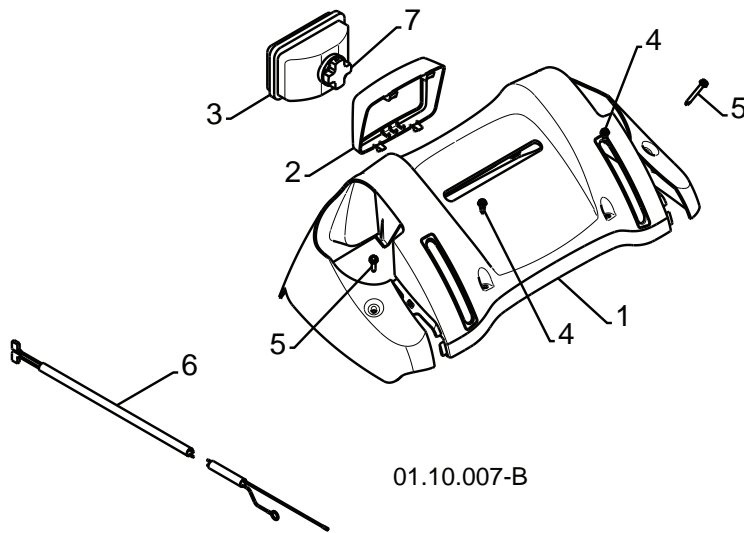

01.10.007-B

KEY NO.	PART NO.	DESCRIPTION
1	182906	CONSOLE PANEL
2	178668	HEADLIGHT BEZEL
3	180927	FLOOD HEADLIGHT
4	184471	SHOULDER SCREW 10-24X.625
5	175262	SCREW 10-24 X 1.25
6	178770	WIRE HARNESS
7	183784	BULB

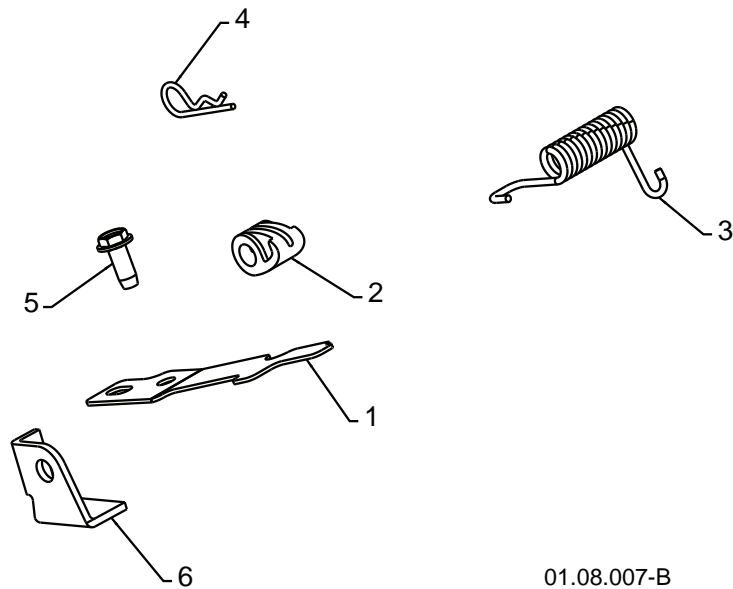

01.08.007-B

KEY NO.	PART NO.	DESCRIPTION
1	412675X004	INTERLOCK SPRING
2	414572	INTERLOCK CAM
3	178831	TORSION SPRING
4	169675	RETAINER
5	17060410	SCREW 1/4-20 X .625
6	421252X004	INTERLOCK STOP

**NOTE:** All component dimensions given in U.S. inches. 1 inch = 25.4 mm  
**IMPORTANT:** Use only Original Equipment Manufacturer (O.E.M.) replacement parts.  
 Failure to do so could be hazardous, damage your snow thrower and void your warranty.

# REPAIR PARTS SNOW THROWER -- MODEL NUMBER PP10527ES (96192002001)

## DRIVE

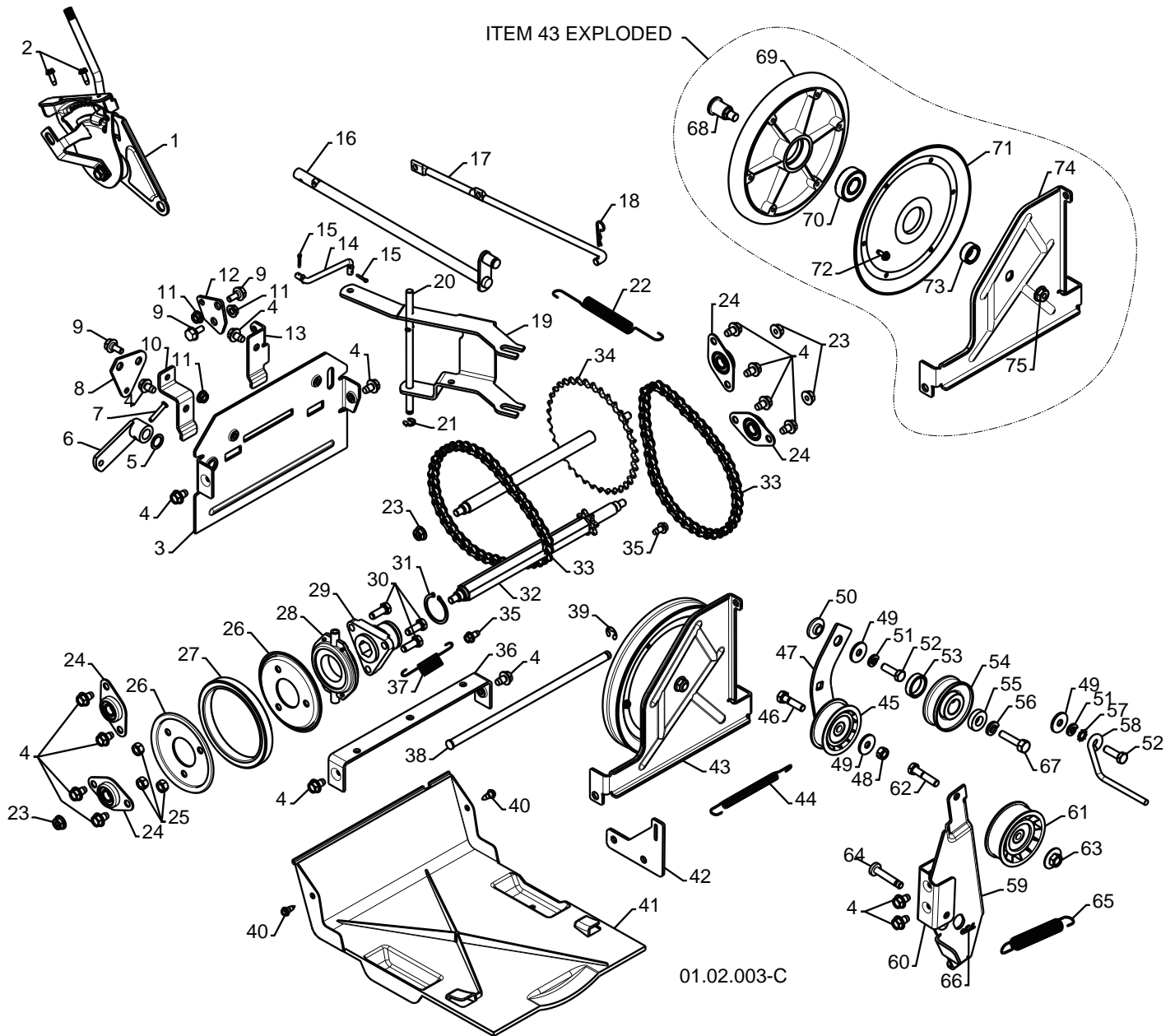

**NOTE:** All component dimensions given in U.S. inches. 1 inch = 25.4 mm  
**IMPORTANT:** Use only Original Equipment Manufacturer (O.E.M.) replacement parts.  
 Failure to do so could be hazardous, damage your snow thrower and void your warranty.

# REPAIR PARTS SNOW THROWER -- MODEL NUMBER PP10527ES (96192002001)

## DRIVE

KEY NO.	PART NO.	DESCRIPTION	KEY NO.	PART NO.	DESCRIPTION
1	198474	SPEED SELECTOR ASSEMBLY	39	12000007	E-RING .375
2	17501010	SCREW 10-24 X .625	40	184471	SHOULDER SCREW
3	402685X428	END PLATE	41	410877	BOTTOM PAN
4	17490508	SCREW 5/16-18 X .50	42	413429X479	SPRING BRACKET
5	57079	WASHER	43	402689	DRIVE PLATE ASSEMBLY
6	405485	CONTROL ARM	44	414557	IDLER SPRING
7	198580	CLEVIS PIN	45	180522	IDLER PULLEY
8	403097X004	SHIFTER PLATE	46	74780520	SCREW 5/16-18 X 1.25
9	402881	SHOULDER BOLT	47	187786	IDLER ARM
10	403096X004	SHIFTER BRACKET	48	73930500	NUT 5/16-18
11	191730	NUT 1/4-20	49	59289	WASHER
12	402856X004	CLUTCH PLATE	50	175331	PIVOT BUSHING
13	416717X004	CLUTCH BRACKET	51	10040500	LOCKWASHER 5/16
14	187101	SHIFTER LINK	52	74610516	SCREW 5/16-18 X 1.00
15	700279	RETAINER	53	409475	SPACER
16	406109	CONTROL SHAFT	54	180478	TRACTION PULLEY
17	402568	CLUTCH ROD	55	400026	WASHER 3/8
18	169675	RETAINER	56	850263	LOCKWASHER 3/8
19	401732	SHIFTER YOKE	57	11050500	LOCKWASHER
20	402310	PIVOT ROD	58	155452	BELT GUIDE
21	402882	RETAINER	59	419925X479	IDLER ARM
22	402878	RETURN SPRING	60	175324X479	IDLER BRACKET
23	751153	NUT 5/16-18	61	180523	IDLER PULLEY
24	408981	BEARING	62	74780524	SCREW 5/16-18 X 1.50
25	73930500	NUT 5/16-18	63	166785	NUT 5/16-18
26	198176X479	RUBBER WHEEL PLATE	64	175330	PIN IDLER PIVOT
27	179831	RUBBER RING	65	178828	IDLER SPRING
28	175344	BEARING	66	85179	RETAINER
29	178613	WHEEL HUB	67	851084	SCREW 3/8-24 X 1.375
30	74760514	SCREW 5/16-18-.875	68	402504	PULLEY SHAFT
31	12000012	RETAINER RING	69	401820	DRIVE PLATE
32	402187	HEX SHAFT	70	198791	BEARING
33	401619	CHAIN	71	402393	PULLEY HALF
34	417234	SPROCKET SHAFT	72	17541008	SCREW 10-24 X .50
35	17490408	SCREW 1/4-20 X .50	73	402511	SPACER BEARING
36	401984X479	SHIFTER BRACKET	74	418894	SWING PLATE
37	180135	SPRING	75	132010	NUT 3/8-16
38	402652	PLATE PIVOT ROD			

**NOTE:** All component dimensions given in U.S. inches. 1 inch = 25.4 mm

**IMPORTANT:** Use only Original Equipment Manufacturer (O.E.M.) replacement parts. Failure to do so could be hazardous, damage your snow thrower and void your warranty.

# REPAIR PARTS SNOW THROWER -- MODEL NUMBER PP10527ES (96192002001) DRIVE

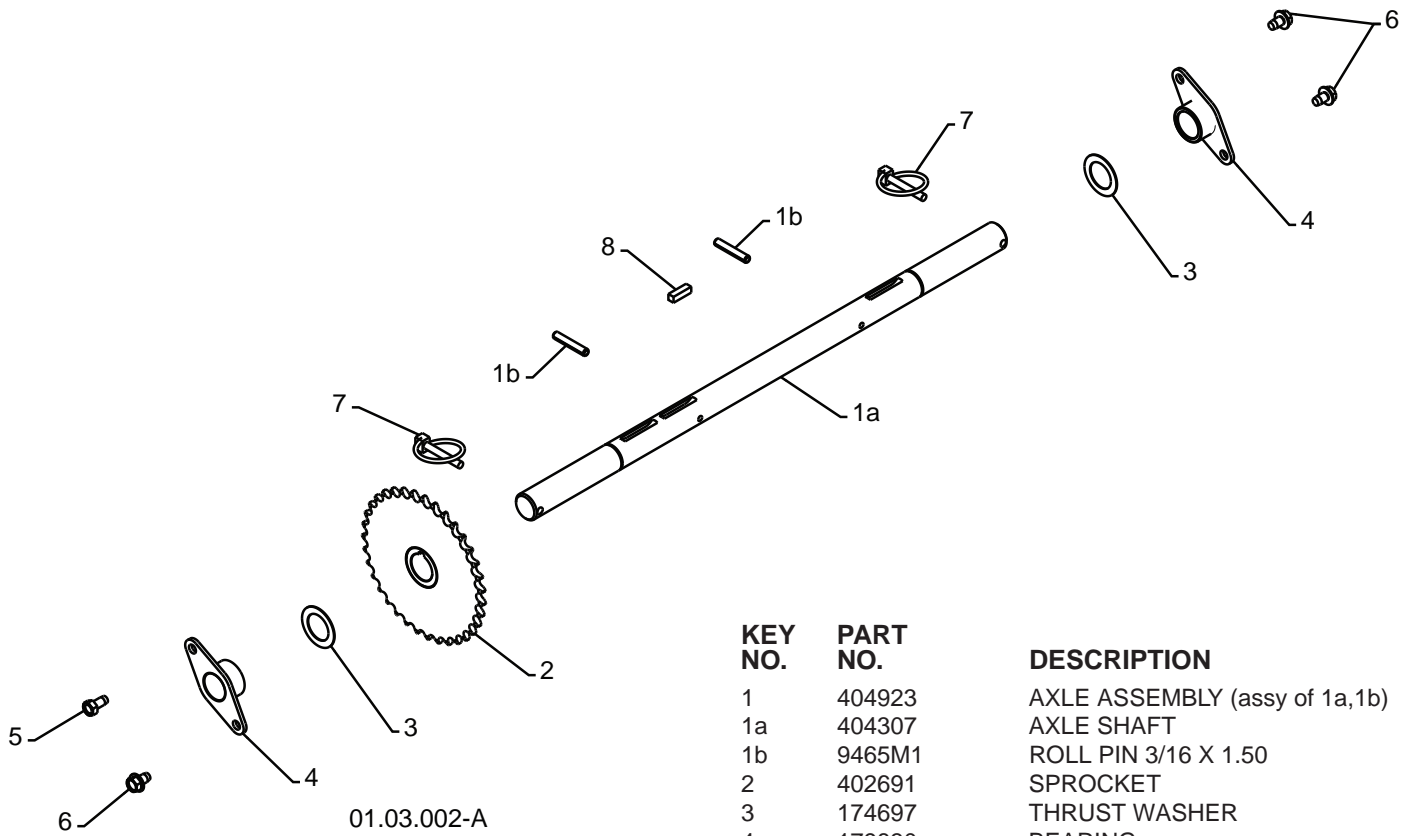

KEY NO.	PART NO.	DESCRIPTION
1	404923	AXLE ASSEMBLY (assy of 1a,1b)
1a	404307	AXLE SHAFT
1b	9465M1	ROLL PIN 3/16 X 1.50
2	402691	SPROCKET
3	174697	THRUST WASHER
4	179830	BEARING
5	146315	SCREW 5/16-18 X .625
6	17490508	SCREW 5/16-18 X .500
7	155443	KLIK PIN 1/4 X 1.50
8	189282	SQUARE KEY

**NOTE:** All component dimensions given in U.S. inches. 1 inch = 25.4 mm  
**IMPORTANT:** Use only Original Equipment Manufacturer (O.E.M.) replacement parts.  
 Failure to do so could be hazardous, damage your snow thrower and void your warranty.

# REPAIR PARTS SNOW THROWER -- MODEL NUMBER PP10527ES (96192002001)

## CHASSIS / ENGINE / PULLEYS

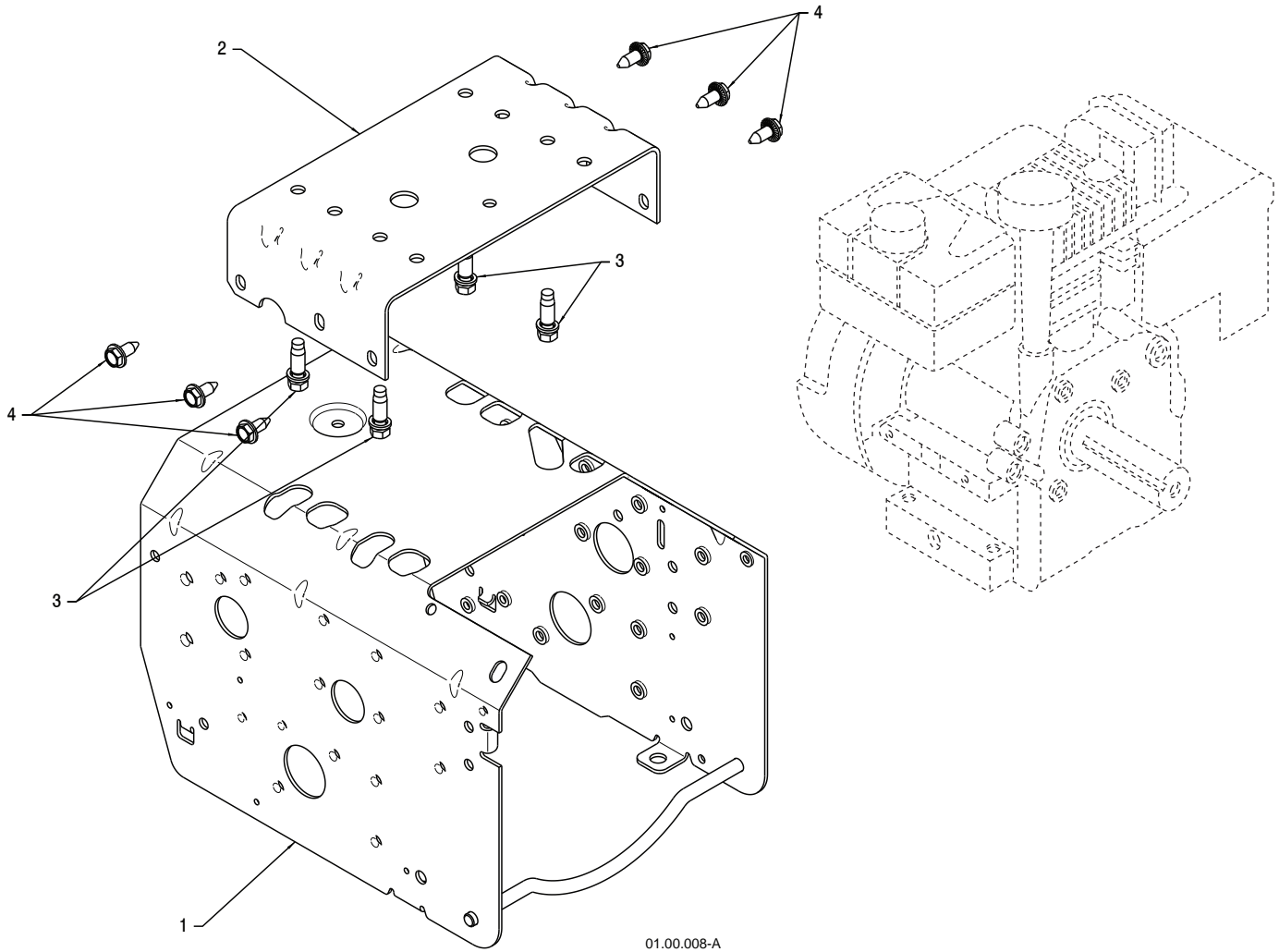

KEY NO.	PART NO.	DESCRIPTION
-	-----	ENGINE, TEC (MODEL LH358SA-159628A)
1	409346X428	FRAME
2	417014X428	ENGINE MOUNT PLATE
3	150406	BOLT 3/8-16
4	150078	SCREW 5/16-18 X .750

**NOTE:** All component dimensions given in U.S. inches. 1 inch = 25.4 mm  
**IMPORTANT:** Use only Original Equipment Manufacturer (O.E.M.) replacement parts.  
 Failure to do so could be hazardous, damage your snow thrower and void your warranty.

**REPAIR PARTS SNOW THROWER -- MODEL NUMBER PP10527ES (96192002001)**  
**CHASSIS / ENGINE / PULLEYS**

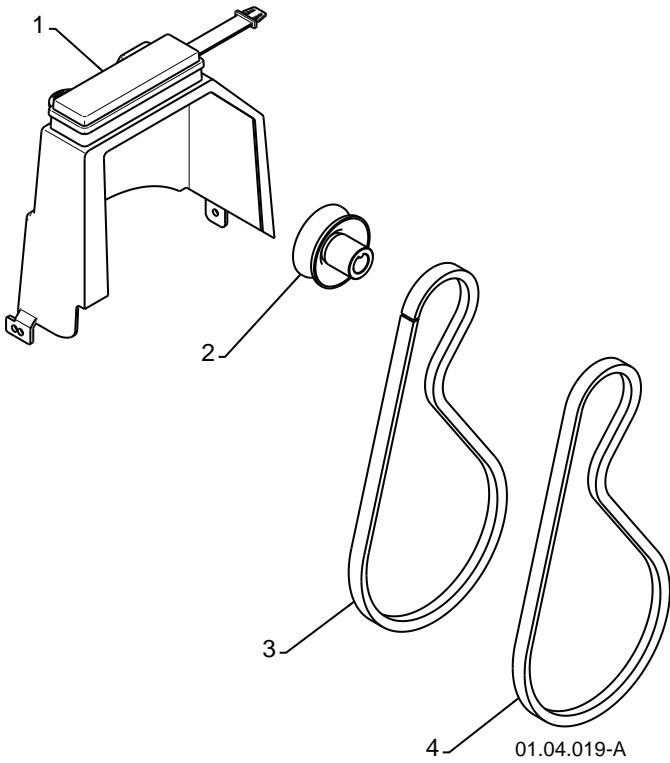

KEY NO.	PART NO.	DESCRIPTION
1	192213	BELT COVER
2	179157	IMPELLER PULLEY
3	419744	TRACTION BELT
4	408007	IMPELLER BELT

**NOTE:** All component dimensions given in U.S. inches. 1 inch = 25.4 mm  
**IMPORTANT:** Use only Original Equipment Manufacturer (O.E.M.) replacement parts.  
 Failure to do so could be hazardous, damage your snow thrower and void your warranty.

# REPAIR PARTS SNOWTHROWER -- MODEL NUMBER PP10527ES (96192002001)

## WHEELS

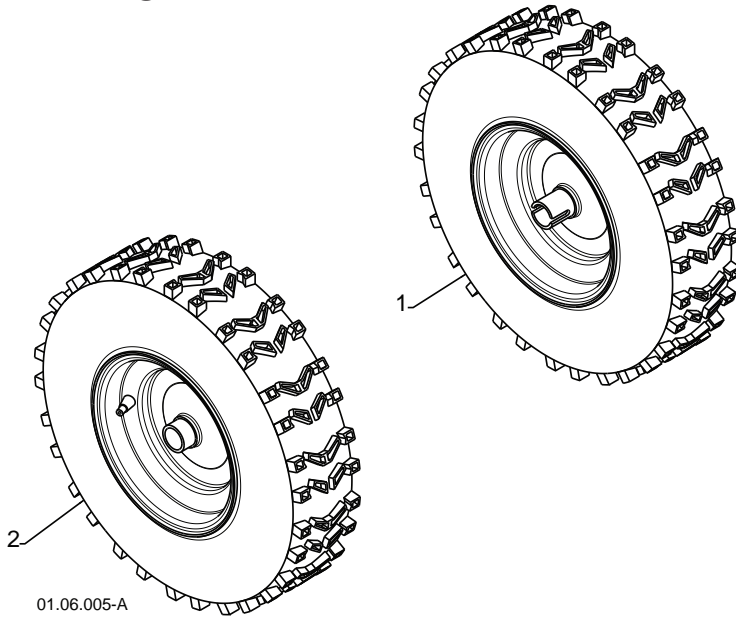

KEY NO.	PART NO.	DESCRIPTION
1	192092X421	WHEEL 16 X 4.80 X LH
2	192093X421	WHEEL 16 X 4.80 X RH

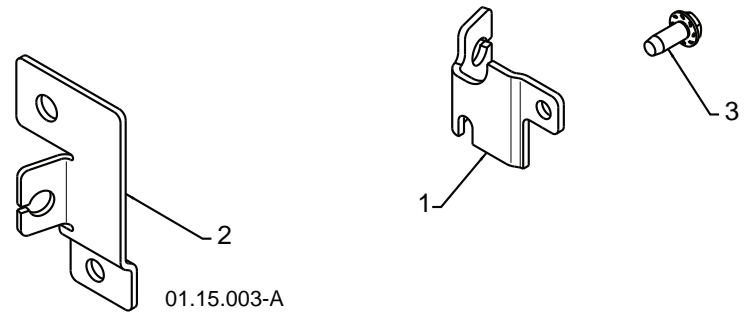

KEY NO.	PART NO.	DESCRIPTION
1	410293	CABLE BRACKET LH
2	410294	CABLE BRACKET RH
3	17060410	SCREW 1/4-20 X .625

**NOTE:** All component dimensions given in U.S. inches. 1 inch = 25.4 mm  
**IMPORTANT:** Use only Original Equipment Manufacturer (O.E.M.) replacement parts.  
 Failure to do so could be hazardous, damage your snow thrower and void your warranty.



# REPAIR PARTS SNOW THROWER -- MODEL NUMBER PP10527ES (96192002001)

## WHEELS

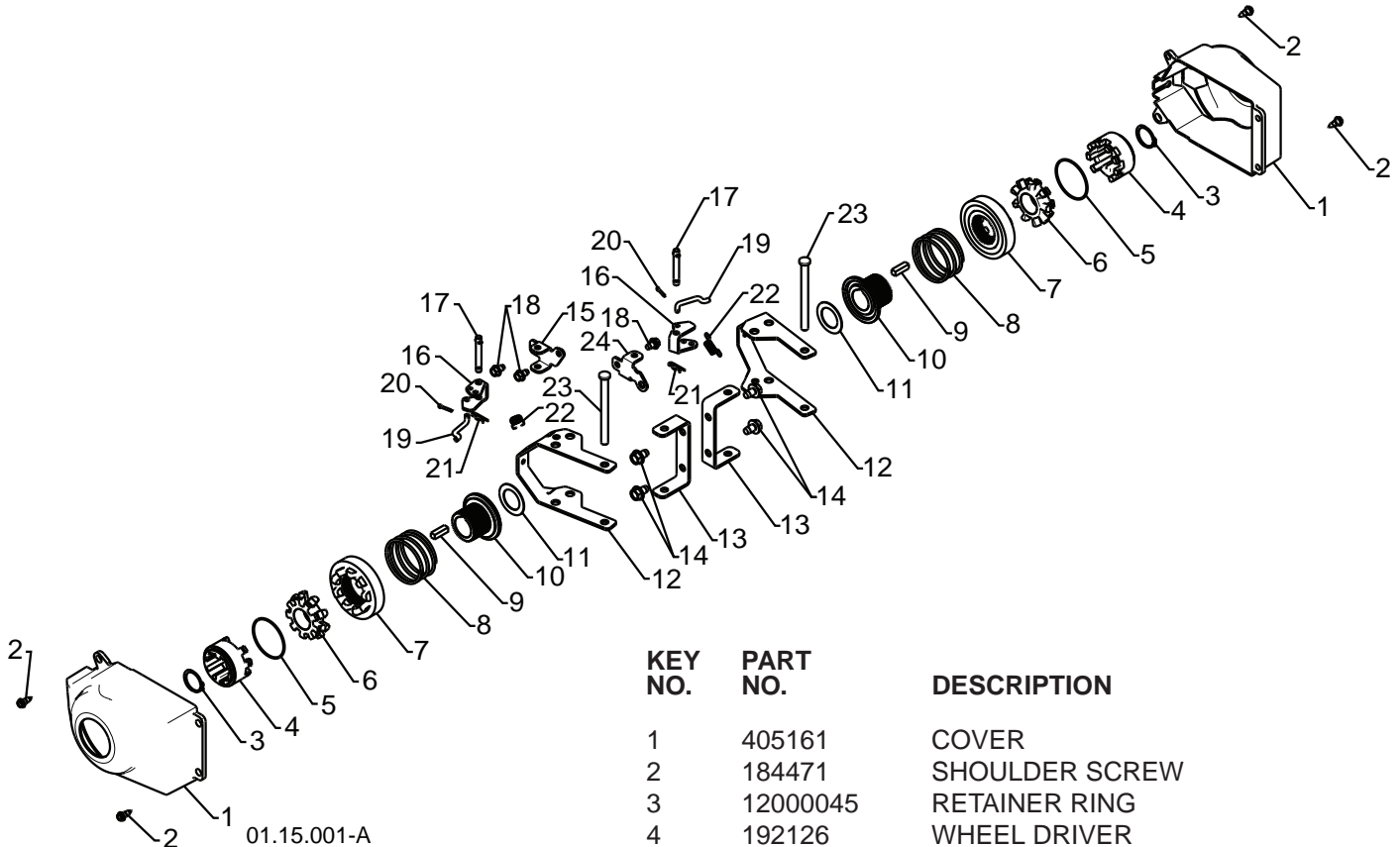

KEY NO.	PART NO.	DESCRIPTION
1	405161	COVER
2	184471	SHOULDER SCREW
3	12000045	RETAINER RING
4	192126	WHEEL DRIVER
5	182466	RETAINER RING
6	187622	WHEEL LOBE
7	194941	CLUTCH SLIDE
8	179139	SPRING
9	189282	SQUARE KEY
10	194940	AXLE LOBE
11	174697	THRUST WASHER
12	193506X479	STEERING YOKE
13	179148X479	STEERING BRACKET
14	17490508	SCREW 5/16-18 X .50
15	194943X008	PIVOT BRACKET
16	194944X008	BELLCRANK
17	181847	BELLCRANK PIN
18	17600406	SCREW 1/4-20 X .375
19	405077	STEERING LINK
20	700279	RETAINER
21	85179	RETAINER
22	193885	SPRING
23	182015	LEVER PIN
24	194939X008	PIVOT BRACKET

**NOTE:** All component dimensions given in U.S. inches. 1 inch = 25.4 mm  
**IMPORTANT:** Use only Original Equipment Manufacturer (O.E.M.) replacement parts.  
 Failure to do so could be hazardous, damage your snow thrower and void your warranty.

# REPAIR PARTS SNOW THROWER -- MODEL NUMBER PP10527ES (96192002001)

## BAG OF PARTS

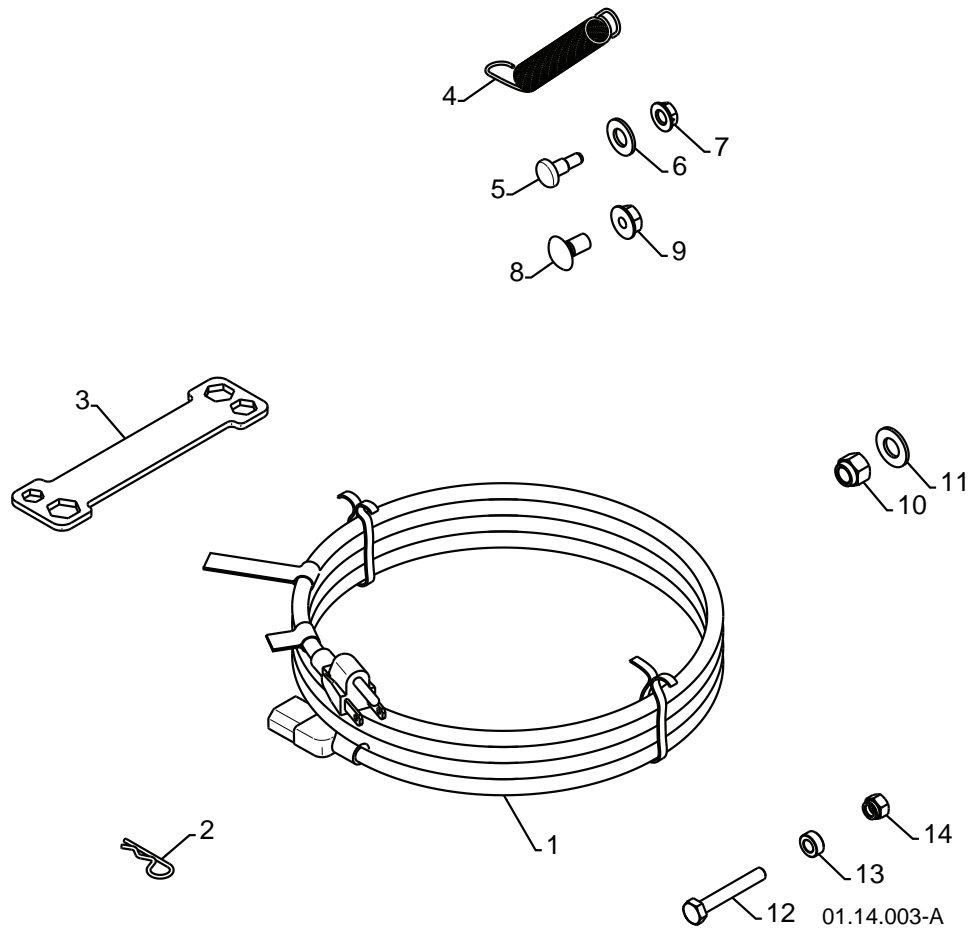

KEY NO.	PART NO.	DESCRIPTION	KEY NO.	PART NO.	DESCRIPTION
1	198563	POWER CORD	8	72250505	CARRIAGE BOLT 5/16-18 X 5/8
2	169675	RETAINER PIN	9	751153	LOCKNUT 5/16-18
3	180684	WRENCH	10	73800600	LOCKNUT 3/8-16
4	184505	REMOTE SPRING	11	19131316	WASHER 3/8
5	179829	SHOULDER BOLT 1/4-20	12	198636	SHEAR BOLT 1/4-20 X 1-3/4
6	179246	NYLON WASHER 1/4-20	13	198638	SPACER
7	191730	LOCKNUT 1/4-20	14	73800400	LOCKNUT 1/4-20

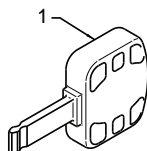

01.14.008-A

KEY NO.	PART NO.	DESCRIPTION
1	35062	SAFETY IGNITION KEY

**NOTE:** All component dimensions given in U.S. inches. 1 inch = 25.4 mm  
**IMPORTANT:** Use only Original Equipment Manufacturer (O.E.M.) replacement parts.  
 Failure to do so could be hazardous, damage your snow thrower and void your warranty.

# REPAIR PARTS SNOW THROWER -- MODEL NUMBER PP10527ES (96192002001)

## DECALS

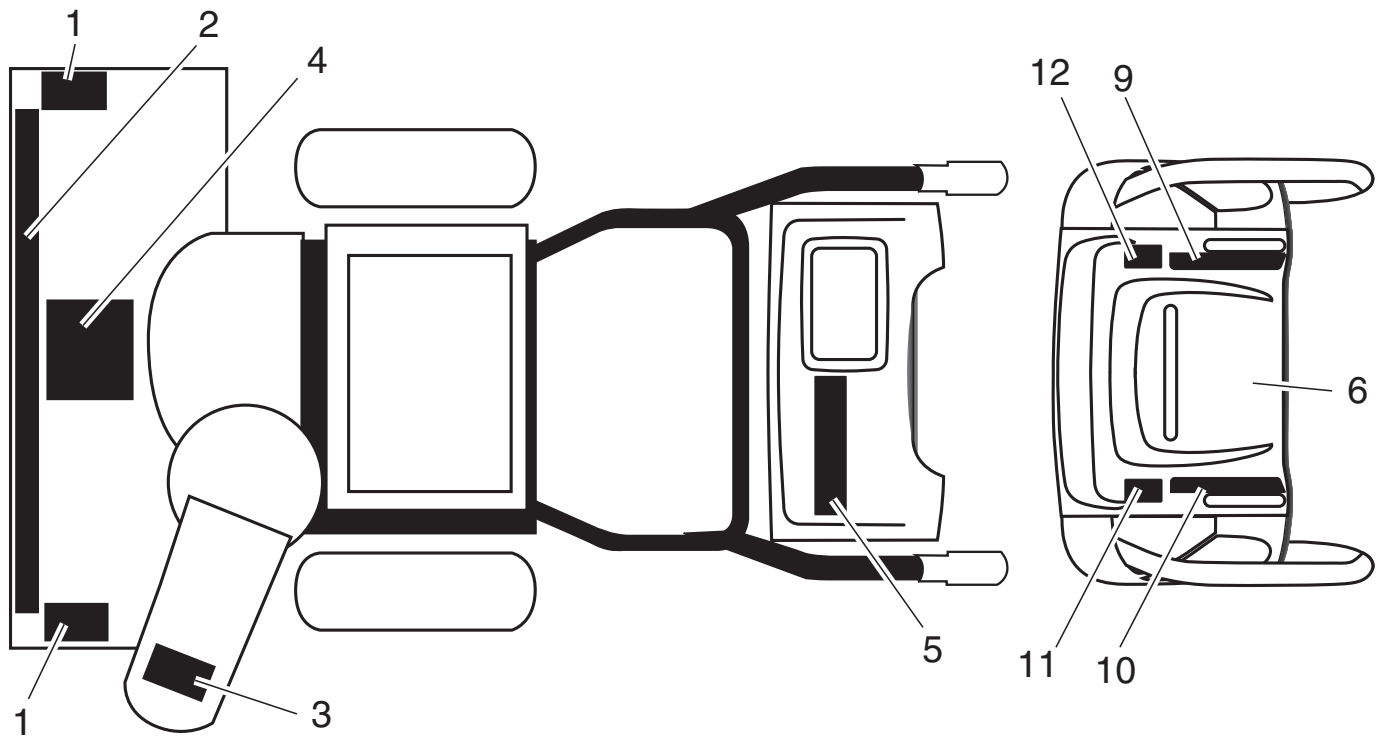

KEY NO.	PART NO.	DESCRIPTION
1	181037	DECAL, DANGER
2	406940	DECAL, POULAN PRO
3	181035	DECAL, DANGER, DEFLECTOR
4	181042	DECAL, DANGER
5	406941	DECAL, POUON PRO
6	181033	DECAL, INSTRUCTION
9	415475	DECAL, SPEED CONTROL
10	183730	DECAL, REMOTE DEFLECTOR CONTROL
11	415399	DECAL, LH TRIGGER
12	415398	DECAL, RH TRIGGER
--	421281	OWNER'S MANUAL, ENGLISH
--	421282	OWNER'S MANUAL, FRENCH

**NOTE:** All component dimensions given in U.S. inches. 1 inch = 25.4 mm  
**IMPORTANT:** Use only Original Equipment Manufacturer (O.E.M.) replacement parts.  
 Failure to do so could be hazardous, damage your snow thrower and void your warranty.

---

# SERVICE NOTES

---

## LIMITED WARRANTY

The Manufacturer warrants to the original consumer purchaser that this product as manufactured is free from defects in materials and workmanship. For a period of two (2) years from date of purchase by the original consumer purchaser, we will repair or replace, at our option, without charge for parts or labor incurred in replacing parts, any part which we find to be defective due to materials or workmanship. This Warranty is subject to the following limitations and exclusions.

1. This warranty does not apply to the engine or components parts thereof. Please refer to the applicable manufacturer's warranty on these items.
2. Transportation charges for the movement of any power equipment unit or attachment are the responsibility of the purchaser. Transportation charges for any parts submitted for replacement under this warranty must be paid by the purchaser unless such return is requested by the manufacturer.
3. The Warranty period for any products used for rental or commercial purposes is limited to 90 days from the date of original purchase.
4. This Warranty applies only to products which have been properly assembled, adjusted, operated, and maintained in accordance with the instructions furnished. This Warranty does not apply to any product which has been subjected to alteration, misuse, abuse, improper assembly or installation, delivery damage, or to normal wear of the product.
5. Exclusions: Excluded from this Warranty are belts, shear pins, normal wear, normal adjustments, standard hardware and normal maintenance.
6. In the event you have a claim under this Warranty, you must return the product to an authorized service dealer.

Should you have any unanswered questions concerning this Warranty, please contact:

Poulan Pro  
Customer Service Department  
1030 Stevens Creek Road  
Augusta, GA 30907 USA

In Canada contact:  
Poulan Pro, Customer Service Department  
5855 Terry Fox Way  
Mississauga, Ontario  
L5V 3E4

giving the complete mfg. ID#, serial number and date of purchase of your product and the name and address of the authorized dealer from whom it was purchased.

THIS WARRANTY DOES NOT APPLY TO INCIDENTAL OR CONSEQUENTIAL DAMAGES AND ANY IMPLIED WARRANTIES ARE LIMITED TO THE SAME TIME PERIODS STATED HEREIN FOR OUR EXPRESSED WARRANTIES. Some areas do not allow the limitation of consequential damages or limitations of how long an implied Warranty may last, so the above limitations or exclusions may not apply to you. This Warranty gives you specific legal rights, and you may have other rights which vary from locale to locale.

This is a limited Warranty within the meaning of that term as defined in the Magnuson-Moss Act of 1975.

# Poulan PRO