

Ref #	Part Number	Qty	Description
1	74610644		"BOLT,HEX"
2	9536H		WHEEL.GAGE.STL.WH
3	101061N		PIVOT ROD LT
4	73680600		SUB= 73690600
5	1663J		ROD PLUNGER T
6	7740J		SUB= 9479R
7	71669		SPRING LT
8	667J		NLA
9	19111216		WASHER M
11	72937		QUADRANT ASSY
12	67337		PIVOT ROD SUP T
13	72140505		BOLT
14	73680500		SUB= 73690500
15	71300		ADJ ROD LT
16	71301		TRUNION T
17	76020312		SUB= 3145
18	73800600		NUT
19	1747J		GRIP LT
20	74230416		SCREW
21	19091616		WASHER
22	73680400		SUB= 73690400
23	122279X		SWAY CABLE
24	72915		PARALLEL ROD ASSY
25	71297		PARALLEL LINK T
26	74760512		BOLT
27	71616		NLA
28	76020416		PIN COTTER 1/8
28A	19151216		WASHER
28B	72140506		BOLT
29	106577X		BRAKE.ASSY.LT.
31	71525		ROD.BRAKE.BLADE.L
32	71524		ROD.BRAKE.BLADE.R
33	62828		V BELT LT
34	121687X		"JACKSHAFT.38""LT"
35	17490612		SCREW
36	17490620		SCREW
37	100668L		SUPPORT PLATE LT
38	121595X		HOUSING
39	8055J		RUNNER T
43	71276		NLA
44	71277		NLA
45	71278		CHANNEL
46	71298		NLA
47	71299		NLA
48	72240608		BOLT
49	19131407		SUB= 55611
50	120626X		SUB= 126338X
51	74610624		BOLT.3/8-24X1-1/2
52	19133808		WASHER T
53	102811X		DEFLECTOR
54	121981X		SUB= 71526
55	121980X		HINGE ROD
56	120244X		BRACKET LT
57	19111016		WASHER
58	10030600		SUB= 10040600
59	19131316		WASHER
60	7375H		BUSHING M
61	7810H		GRIPCO NUT
62	107339X		DECAL HYT
64	110452X		NUT PUSH M

Ref #	Part Number	Qty	Description
64	110452X		NUT PUSH M
65	101062K		BUSHING LT
66	19131614		WASHER
67	105304X		CAP-SLEEVE LT
68	19171616		WASHER

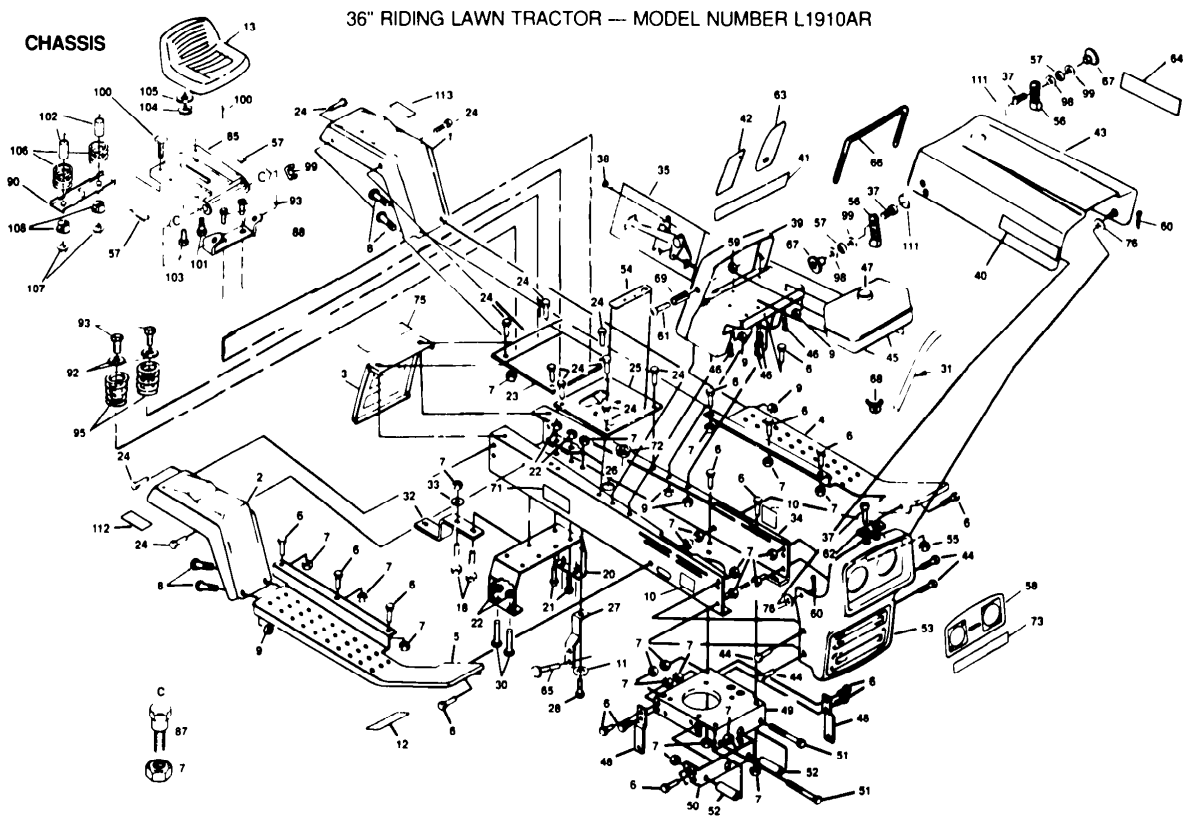

Ref #	Part Number	Qty	Description
1	388J366		FENDER
2	389J366		FENDER
3	120019X		REAR COVER T
4	1539J		SUB= 1539J363
5	1540J		SUB= 1540J363
6	74760512		BOLT
7	73680500		SUB= 73690500
8	74760508		BOLT
10	105788X		NLA
11	19112410		WASHER
12	1133J		SUB= 101892X
13	121076X		SUB= 140119
18	74780520		BOLT
20	5929J		SUPPORT LT
21	74760616		BOLT
22	73680600		SUB= 73690600
23	121783X		SUB= 122464X
24	17490508		SCREW LT
25	120435X015		CHASSIS CVR
26	5930J		PLATE
27	120821X		AXLE LT
28	74760516		SUB= 77394
30	74760644		BOLT
31	7119J		SUB= 295J
32	71205		TOW HITCH
33	19122006		WASHER
34	120394X		CHASSIS
35	121734X		SUB= 132768
37	74191008		SCREW
38	17080408		SCREW
39	120016X		DASH T
40	109322X		DECAL
41	1136J		NLA
42	120086X		NLA
43	104355X366		HOOD WELDMENT
44	98000131		NLA
45	73427		TANK.FUEL.LT
46	17760412		SCREW LT
47	74145		FUEL CAP
48	71190		BRAKE ROD BRA T
49	1839J		ENGINE BASE
50	71178		ROCKER BAR SUPP
51	74760848		SUB= 64606
52	67151		ROCKER PIVOT LT
53	109734X		GRILL FRAME
54	74307		NLA
55	4632H		NUT STD
56	109808X		HOOD LATCH T
57	121251X		STRIP FORM
58	109324X		NLA
59	73731000		NUT
60	76020312		SUB= 3145
61	74981020		SCREW
62	470J		HOOD BUMPER
63	120357X		DECAL
64	109321X		NLA
65	17490512		SCREW
66	8937R		SUB= 892J
67	2029J		WELDNUT
68	6999R		SUB= 123487X

Ref #	Part Number	Qty	Description
68	6999R		SUB= 123487X
69	7206J		SPACER LT
71	7827J		DECAL
73	104290X		DECAL LT
75	109323X		NLA
76	19111216		WASHER M
85	121247X		SUB= 155925
87	105529X		SUB= 139888
88	105513X		SUB= 140551
90	121246X		BRKT SWITCH
92	19131614		WASHER
93	17490616		SCREW GTV
95	121067X		SPRING T
98	19060716		NLA
99	110357X		WASHER LT
100	72170410		BOLT
101	121144X		SUB= 127018X
102	121249X		SPACER SPLIT
103	74780816		BOLT
104	10040800		LOCKWASHER
105	19171912		WASHER
106	121250X		SPRING
107	73900400		NUT T
108	121248X		BUSHING
111	110356X		SNAP CAP LT
112	106974X		SUB= 133796
113	110327X		DECAL

36" RIDING LAWN TRACTOR — MODEL NUMBER L1910AR

CLUTCH-BRAKE DRIVE

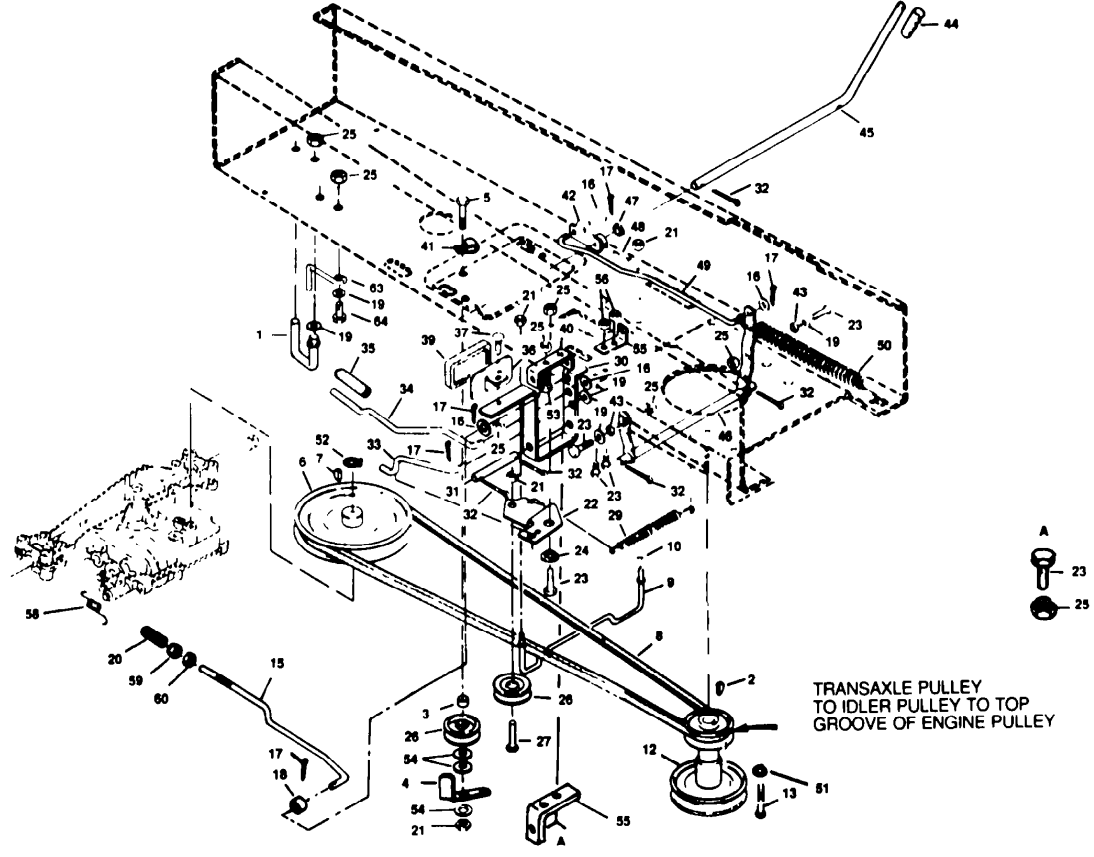

Ref #	Part Number	Qty	Description
1	5942J		BELT GUIDE T
3	122086X		SPACER
4	6278J		BELT KEEPER T
5	74760565		SUB= 74930624
6	5925J		PULLEY-TRANS T
7	2228M		SUB= 2228M1
8	121979X		SUB= 144200
9	71241		MID BELT GUIDE LT
10	19131416		WASHER
12	121351X		SUB= 139417
13	74770728		BOLT RER
15	120297X		NLA
16	19131216		WASHER
17	76020312		SUB= 3145
18	19111212		WASHER
19	19111216		WASHER M
20	106888X		SPRING ROD LT
21	73680600		SUB= 73690600
22	71201		IDLER BRACKET
23	74760512		BOLT
24	71202		BUSHING
25	73680500		SUB= 73690500
26	67400		SUB= 104679X
27	74760624		SUB= 74930624
29	2044J		IDLER SPRING
30	6048J		FOOT PEDAL LT
31	71223		NLA
32	76020416		PIN COTTER 1/8
33	74419		SUB= 7717J
34	373J		PARK BRK ROD T
35	7821J		SUB= 71226
36	71222		PEDAL PLATE LT
37	72140506		BOLT
39	67365		FOOT PAD LT
40	71199		PEDAL BRACKET T
42	73229		NLA
43	71195		NLA
44	7822J		SUB= 71246
45	71242		CLUTCH HANDLE L
46	71191		NLA
47	19171616		WASHER
48	2364J		SUB= 2882J
49	74474		BALDE ROD LT
50	71248		NLA
51	10040700		LOCKWASHER
52	12000028		SUB= 2267J
53	74780512		BOLT
54	19131210		WASHER
55	71204		SWITCH BRKT
56	73680500		SUB= 73690500
58	110422X		SUB= 146682
59	73680600		SUB= 73690600
60	73350600		NUT
63	105597X		BELT RETAINER GT
64	74760516		SUB= 77394



**ELECTRIC AND ENGINE**

**36" RIDING LAWN TRACTOR — MODEL NUMBER L1910AR**

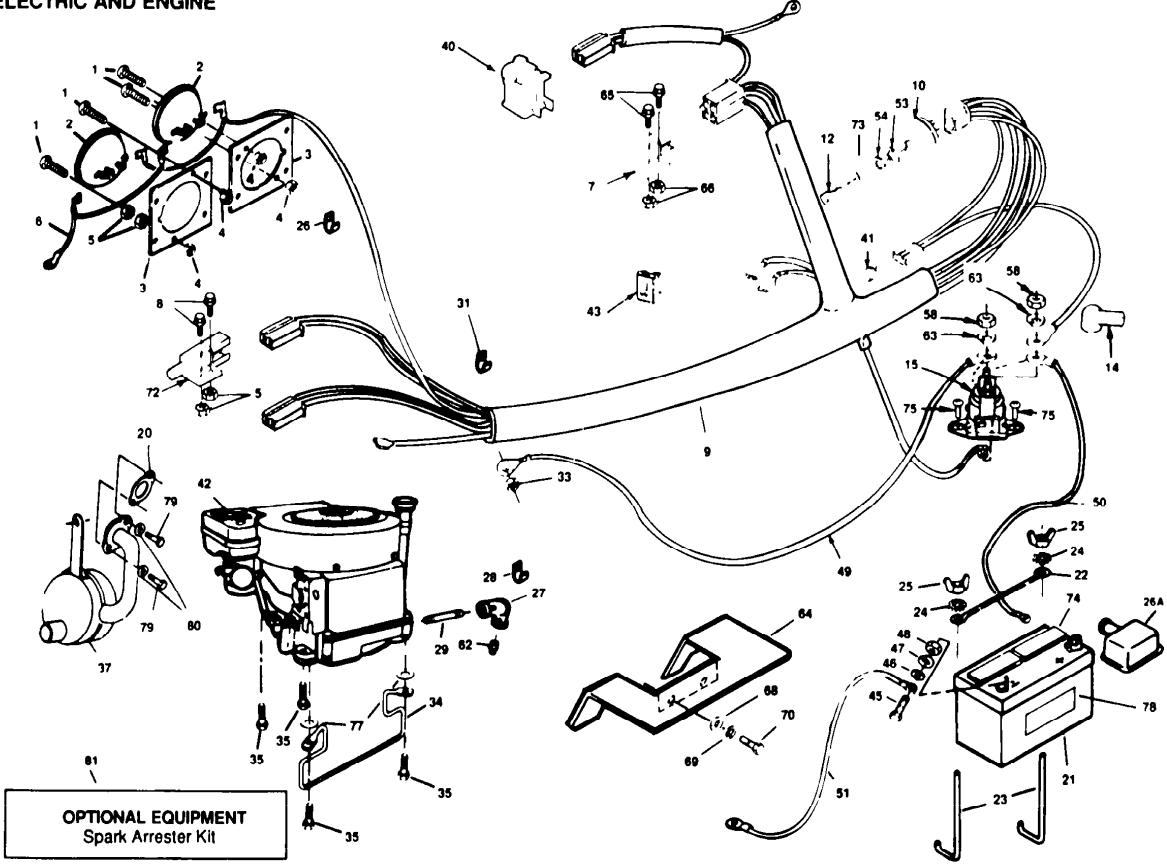

Ref #	Part Number	Qty	Description
1	74291016		NLA
2	6774R		SUB= 60941
3	73025		SUB= 2702J
4	4632H		NUT STD
5	73731000		NUT
6	71706		WIRE ASSY
7	109553X		SWITCH INTERLOCKT
8	74191008		SCREW
9	121354X		HARNNESS
10	4406R		SUB= STD365402
12	7552H		SUB= STD365410
14	719J		SUB= 154336
15	109081X		SUB= 146154
17	73510400		NUT
20	1407J		SUB= 272293
21	121310X		SUB= 123888X
22	110134X		ROD T
23	70456		"BOLT, BATTERY"
24	11030400		LOCKWASHER GT
25	73490400		SUB= 146525
26	2521R		CLIP SB
26A	225J		BATTERY TERMINAL COVER
27	13200300		ELBOW
28	5320R		INSUL CLIP T
29	13280324		PIPE NIPPLE
31	6794R		SUB= 2751R
33	53490		NUT
34	1795J		BELT KEEPER LT
35	17490624		SCREW LT
37	109560X		MUFFLER LT
40	121305X		SWITCH SEAT
41	108824X		FUSE HYT
42	252707		ENGINE-B&S
43	110712X		SWITCH LT
45	74760412		BOLT LT
46	19091016		WASHER
47	10040400		LOCKWASHER
48	73220400		SUB= 50675
49	2957J		"CABLE T, BATTERY"
50	4559J		SUB= 597J
51	596J		SUB= 2955J
53	19221616		WASHER T
54	109788X		SUB= 124211X
58	73350400		NUT
62	91084		PLUG OIL DRAIN
63	10090400		SUB= 10040400
64	109730X		SHIELD HEAT LT
65	71031008		SCREW
66	73951000		"NUT,KEPS"
68	19101216		WASHER
69	10040400		LOCKWASHER
70	74780416		NLA
72	104445X		SWITCH-INTER. GT
73	109787X		SUB= 147626
74	121300X		CAP BATTERY
75	74230408		"SCREW,MACHINE"
77	19131210		WASHER
78	121549X		DECAL
79	74760512		BOLT
80	10040500		LOCKWASHER

Ref #	Part Number	Qty	Description
80	10040500		LOCKWASHER
81	100092M		SPARK ARRESTER KIT
	121345X		NLA
	122126X		OWNER'S MANUAL
	101539X		SHEET INSTR LT
	101572X		SHEET-INSTRUCTION (FRENCH)

### SCHEMATIC DIAGRAM

36" RIDING LAWN TRACTOR — MODEL NUMBER L1910AR

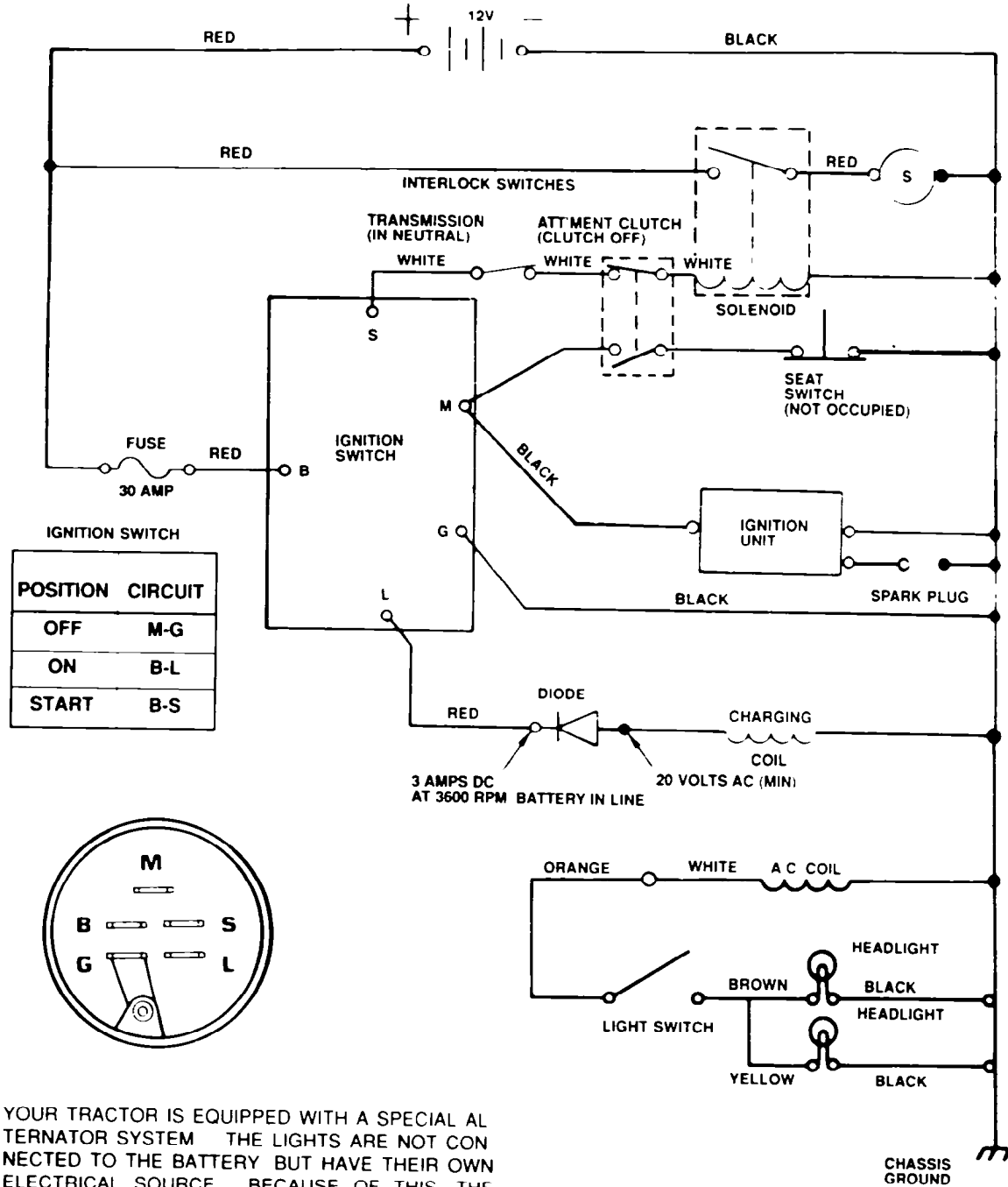

YOUR TRACTOR IS EQUIPPED WITH A SPECIAL ALTERNATOR SYSTEM. THE LIGHTS ARE NOT CONNECTED TO THE BATTERY BUT HAVE THEIR OWN ELECTRICAL SOURCE. BECAUSE OF THIS THE BRIGHTNESS OF THE LIGHTS WILL CHANGE WITH THE ENGINE SPEED. AT IDLE SPEED THE LIGHTS WILL DIM AS THE ENGINE IS SPEEDED UP THE LIGHTS WILL BECOME THEIR BRIGHTEST.

**WIRING INSULATED CLIPS**  
 If Insulated Clips and Cable Ties were removed for servicing of unit they should be replaced to properly secure your wiring.

Ref #	Part Number	Qty	Description
			REFER TO IMAGE

36" RIDING LAWN TRACTOR — MODEL NUMBER L1910AR

STEERING AND WHEELS

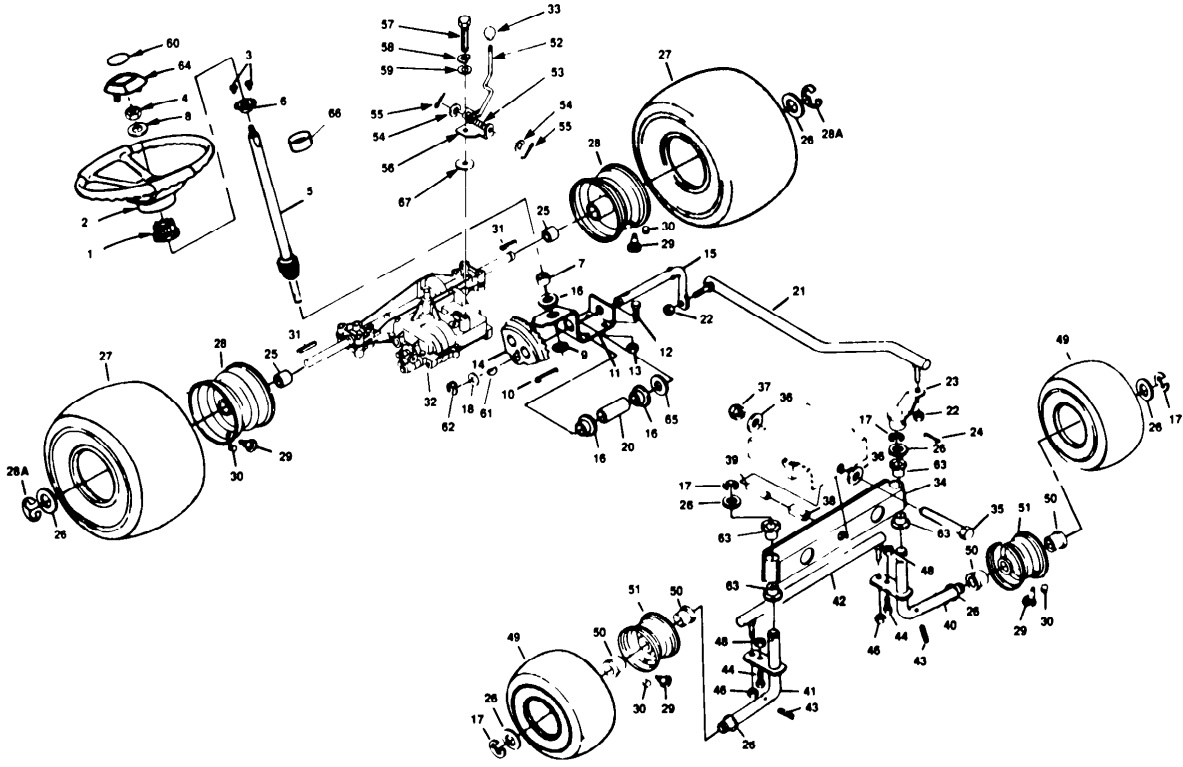

Ref #	Part Number	Qty	Description
1	100711L		ADAPTER LT
2	100713N		SUB= 150547
3	17431008		SUB= 98000165
4	73940800		SUB= 73360800
5	677A208		STEERING SHFT LT
6	1554J		SUB= 155108
7	74580		SHAFT SPACER LT
8	100712K		WASHER
9	19212013		WASHER
10	1572H		SUB= 2882J
11	120017X		STEERING BRKT T
12	74760512		BOLT
13	73680500		SUB= 73690500
14	101060M		GEAR LT
15	101429X		STEERING ROD LT
16	71208		BUSHING
17	12000029		RING
18	19211621		WASHER
20	101171K		SPACER LT
21	71219		NLA
22	7810H		GRIPCO NUT
23	71185		STEERING ARM T
24	62079		SPIROL PIN
25	109502X		SPACER LT
26	121749X		WASHER
27	71653		SUB= 122074X
	4445H1		TUBE.4.0/4.8-8
28	71652		SUB= 106108X427
28A	12000001		E-RING LT
29	65139		VALVE STEM LT
30	59192		VALVE CAP
31	2703J		SUB= 123583X
32	4360-6		TRANSAXLE ASSY
33	106279X		CONTROL KNOB LT
34	104532X		SUB= 108894X
35	74760848		SUB= 64606
36	19171416		WASHER
37	73680800		NUT LTV
38	67151		ROCKER PIVOT LT
39	71188		PIVOT SPACER LT
40	677A169		KINGPIN ASSY LH
41	677A168		NLA
42	73240		TIR ROD LT
43	9530R		SUB= 5142H
44	74760612		SUB= 74780612
46	73810500		NUT.LOCK.5/16-24
48	73680600		SUB= 73690600
49	71651		SUB= 122073X
	4479R		SUB= 59904
50	625J		"LT, BEARING"
51	677A98		RIM ASSY LT
52	121407X		NLA
53	105700X		SPRING LT
54	19151216		WASHER
55	76020416		PIN COTTER 1/8
56	106632X		SHIFT PLATE LT
57	71040412		SUB= 74550412
58	10040400		LOCKWASHER
59	19091210		WASHER LT
60	109325X		SUB= 127075

Ref #	Part Number	Qty	Description
60	109325X		SUB= 127075
61	2228M		SUB= 2228M1
62	12000040		KLIP RING
63	3366R		COL. SRTG. BEAR.
64	100710L		INSERT-WHEEL LT
65	19211616		WASHER LT
66	109420X		SLEEVE LT



### 11 H.P. RIDING LAWN TRACTOR -- MODEL NUMBER L1910AR

#### TRANSAXLE FOOTE - MODEL NUMBER 4360-6

WARRANTY SERVICE MUST BE PERFORMED BY AN  
AUTHORIZED FOOTE DEALER (REFER TO PAGE 37)

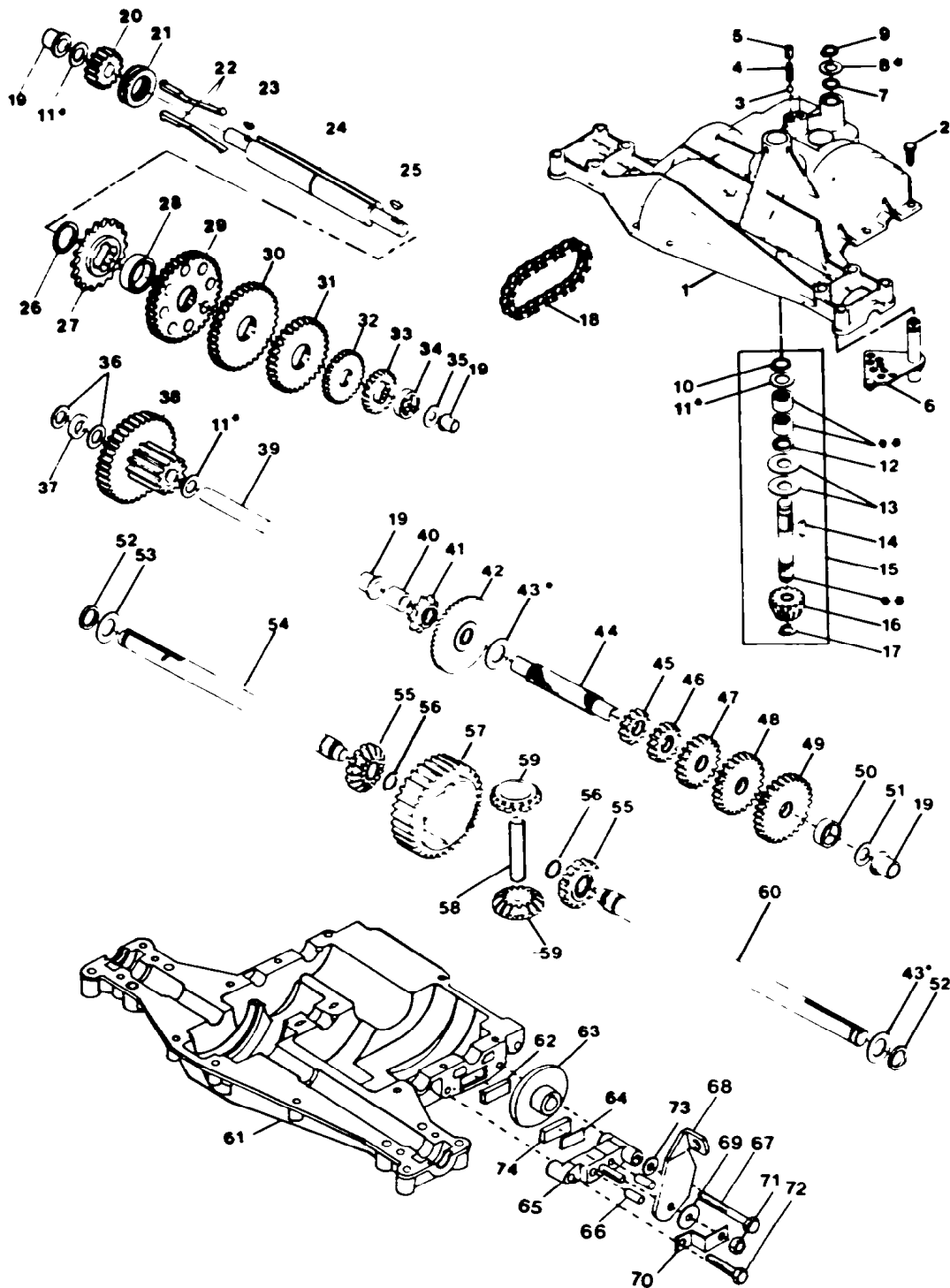

Ref #	Part Number	Qty	Description
1	3865		HOUSING UPPER
2	1919		SCREW
3	1151		BALL DETENT
4	3626		SPRING, DETENT
5	3623		SCREW, SET
6	4336		ASSY SHIFTER
7	3884		O-RING
8	3885		WASHER PLAIN
8A	3886		WASHER PLAIN
8B	3887		WASHER PLAIN
8C	3888		WASHER PLAIN
8D	3889		WASHER PLAIN
8E	3121		WASHER PLAIN
8F	3890		WASHER PLAIN
9	1100		RING RETAINING
10	1099		RING RETAINING
11	1959		WASHER PLAIN
11A	1441		WASHER PLAIN
11B	1423		WASHER, PLAIN .632 X 1.00 X .026
11C	1082		WASHER PLAIN
11D	1424		WASHER PLAIN
11E	1068		WASHER PLAIN
11F	1425		WASHER PLAIN
11G	1358		WASHER PLAIN
11H	1145		WASHER, PLAIN .632 X 1.00 X .060
11I	1319		WASHER PLAIN
12	3312		O-RING
13	3876		WASHER, PLAIN .632 X 1.38 X .046
14	1374		KEY WOODRUFF #9
15	4134		ASSY KIT INPUT SHAFT
16	3590		PINION, BEVEL, 14 TEETH
17	3624		RING, RETAINING
18	3625		CHAIN, 24 PITCHES
19	1542		BEARING, FLANGE
20	3773		GEAR SPUR, 14 TEETH
21	3631		COLLAR CLUTCH
22	3828		KEY CLUTCH
23	1369		KEY WOODRUFF #3
24	3883		SHAFT INTERMEDIATE
25	1375		KEY, WOODRUFF, #61
26	3627		RING, RETAINING
27	3830		SPROCKET, 18 TEETH
28	3841		SPACER
29	3786		GEAR, SPUR, 37 TEETH
30	3867		GEAR, SPUR, 30 TEETH
31	3783		GEAR, SPUR, 25 TEETH
32	3869		GEAR, SPUR, 22 TEETH
33	3741		GEAR SPUR
34	3715		SPACER
35	3628		WASHER, PLAIN .640 X 1.37 X .061
36	1423		WASHER, PLAIN .632 X 1.00 X .026
37	3422		SPACER .630 X 1.00 X .169
38	4286		ASSY GEAR COMB 12&35 TEETH
39	3877		SHAFT IDLER
40	3901		SPACER .635 X .875 X .755
41	3645		SPROCKET, 9 TEETH
42	3853		GEAR, BEVEL, 42 TEETH
43	3749		WASHER PLAIN
43A	3652		WASHER PLAIN
43B	3693		WASHER PLAIN

Ref #	Part Number	Qty	Description
43B	3693		WASHER PLAIN
43C	3653		WASHER PLAIN
43D	3408		WASHER PLAIN
43E	3732		WASHER PLAIN
43F	3184		WASHER, PLAIN .758 X 1.25 X .031
43G	3733		WASHER PLAIN
43H	3198		WASHER PLAIN
43I	3734		WASHER PLAIN
43J	3735		WASHER PLAIN
43K	3736		WASHER PLAIN
43L	3180		WASHER PLAIN
44	3882		SHAFT, DRIVE
45	3646		GEAR, SPUR, 12 TEETH
46	3866		GEAR, SPUR, 20 TEETH
47	3719		GEAR, SPUR, 25 TEETH
48	3868		GEAR, SPUR, 28 TEETH
49	3683		GEAR, SPUR, 31 TEETH
50	3714		SPACER
51	1145		WASHER, PLAIN .632 X 1.00 X .060
52	3191		SEAL FELT
53	3180		WASHER PLAIN
54	3880		AXLE LEFT HAND
55	3780		GEAR, MITER, 15 TEETH
56	3656		RING, RETAINING
57	3839		GEAR, SPUR, 32 TEETH
58	3919		SHAFT, CROSS
59	3781		GEAR, MITER, 15 TEETH
60	3881		AXLE, R.H.
61	3864		HOUSING LOWER
62	3920		PUCK, FRICTION
63	3276		DISC, BRAKE
64	3758		SPACER
65	3916		JAW, BRAKE
66	3843		PIN, DOWEL
67	3915		SCREW TAPPING
68	3768		LEVER, ACTUATING
69	3760		WASHER, PLAIN .321 X 1.00 X .055
70	3917		BRACKET, ANTI-ROTATION
71	3847		LOCKNUT 5/16-24
72	3724		SCREW TAPPING
73	3906		WASHER PLAIN
74	3907		PUCK, FRICTION
75	4300		GREASE