

Poulan

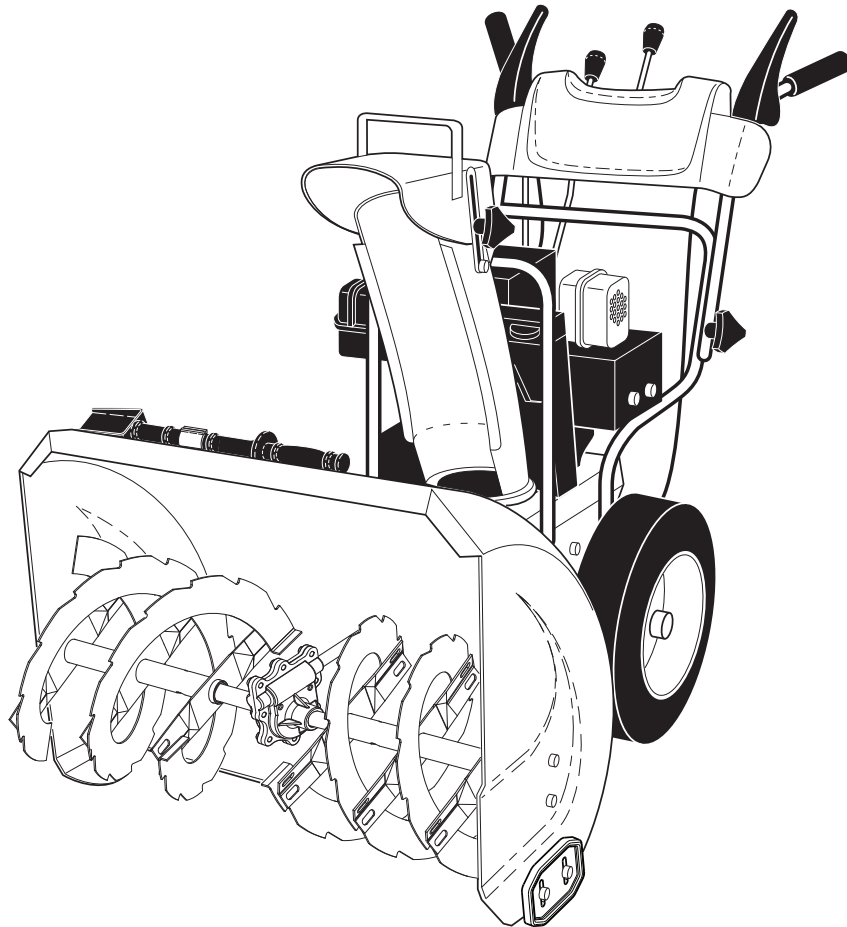

PART'S MANUAL

**MODEL NUMBER:
P14530ES
SNOW THROWER**

⚠ WARNING:
Read the Owner's Manual and follow all Warnings and Safety Instructions. Failure to do so can result in serious injury.

Always Wear Eye Protection During Operation

Gasoline containing up to 10% ethanol (E10) is acceptable for use in this machine. The use of any gasoline exceeding 10% ethanol (E10) will void the product warranty.

REPAIR PARTS SNOW THROWER - MODEL P14530ES (96198004502)
AUGER HOUSING / IMPELLER ASSEMBLY

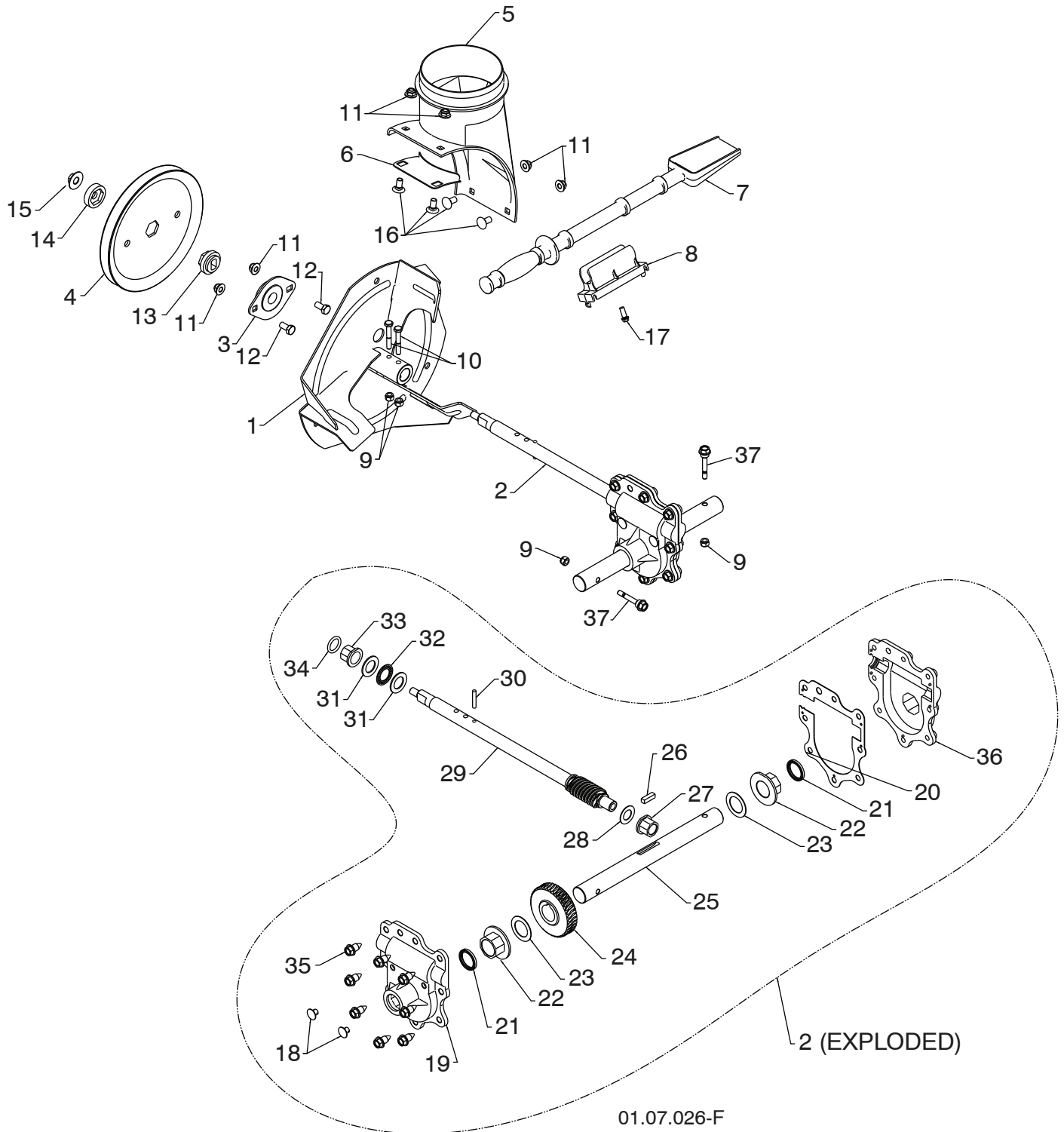

01.07.026-F

NOTE: All component dimensions given in U.S. inches. 1 inch = 25.4 mm
IMPORTANT: Use only Original Equipment Manufacturer (O.E.M.) replacement parts.
 Failure to do so could be hazardous, damage your snow thrower and void your warranty.

REPAIR PARTS SNOW THROWER - MODEL P14530ES (96198004502)
AUGER HOUSING / IMPELLER ASSEMBLY

KEY NO.	PART NO.	DESCRIPTION
1	532 18 41-05	IMPELLER
2	532 42 71-48	GEARBOX ASSEMBLY
3	532 18 89-09	BEARING
4	532 42 71-46	IMPELLER PULLEY
5	532 44 24-38	DISCHARGE BASE
6	532 18 40-95	CORNER BRACKET
7	532 19 21-99	CLEAN OUT TOOL
8	532 40 54-00	TOOL CLIP
9	873 80 04-00	NUT 1/4-20
10	874 78 04-26	SCREW 1/4-20 X .625
11	532 42 79-42	NUT 5/16-18
12	532 16 31-83	SCREW 5/16-18 X .625
13	532 42 71-45	IMPELLER HUB
14	532 42 71-54	IMPELLER SLEEVE
15	532 14 52-12	FLANGE NUT 3/8-16
16	532 18 03-55	CARRIAGE BOLT
17	532 19 41-89	SCREW 13-16 X .625
18	532 40 77-60	PLUG
19	532 42 73-02	GEARBOX COVER RH
20	532 42 73-45	GASKET
21	532 40 77-70	SEAL
22	532 40 77-62	BEARING
23	532 17 46-97	THRUST WASHER 1.00
24	532 40 77-63	WORM GEAR
25	532 40 77-64	AUGER SHAFT
26	532 18 92-82	SQUARE KEY
27	532 40 77-58	BEARING
28	532 17 46-83	THRUST WASHER
29	532 42 71-47	IMPELLER SHAFT
30	532 18 42-05	ROLL PIN
31	532 17 46-81	THRUST WASHER
32	532 17 46-84	THRUST BEARING
33	532 40 77-69	BEARING
34	532 40 77-68	O-RING
35	532 40 77-67	SCREW 5/16-18 X .750
36	532 42 73-17	GEARBOX COVER LH
37	532 19 20-90	SHEAR BOLT

NOTE: All component dimensions given in U.S. inches. 1 inch = 25.4 mm
IMPORTANT: Use only Original Equipment Manufacturer (O.E.M.) replacement parts.
 Failure to do so could be hazardous, damage your snow thrower and void your warranty.

REPAIR PARTS SNOW THROWER - MODEL P14530ES (96198004502)
AUGER HOUSING / IMPELLER ASSEMBLY

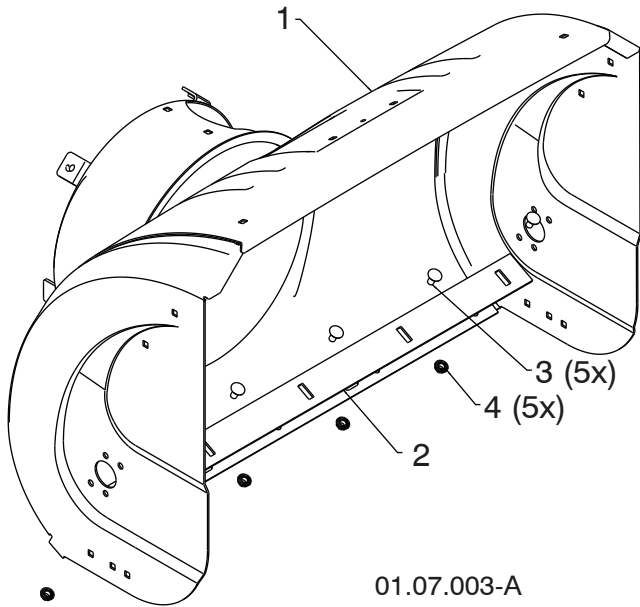

KEY NO.	PART NO.	DESCRIPTION
1	532 41 52-91	AUGER HOUSING
2	532 40 76-45	SCRAPPER BAR
3	872 27 05-05	CARRIAGEBOLT 5/16-18X.625
4	532 15 53-77	NUT 5/16-18

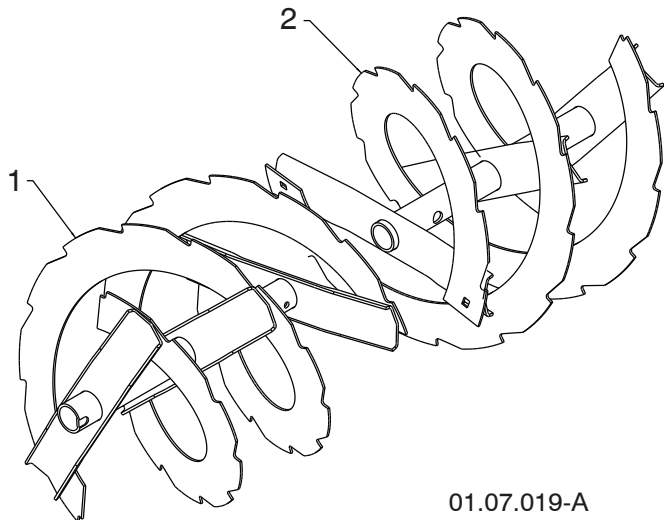

KEY NO.	PART NO.	DESCRIPTION
1	532 42 11-24	AUGER ASSEMBLY 30 LH
2	532 42 11-25	AUGER ASSEMBLY 30 RH

NOTE: All component dimensions given in U.S. inches. 1 inch = 25.4 mm
IMPORTANT: Use only Original Equipment Manufacturer (O.E.M.) replacement parts.
 Failure to do so could be hazardous, damage your snow thrower and void your warranty.

REPAIR PARTS SNOW THROWER - MODEL P14530ES (96198004502)
AUGER HOUSING / IMPELLER ASSEMBLY

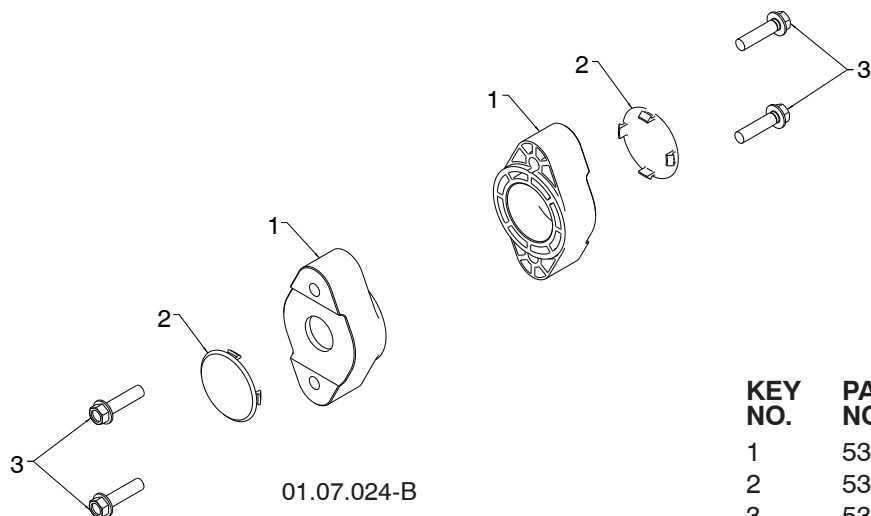

KEY NO.	PART NO.	DESCRIPTION
1	532 42 04-78	AUGER BEARING
2	532 41 19-39	BEARING PLUG
3	532 17 95-82	SCREW 5/16-18 X 1.00

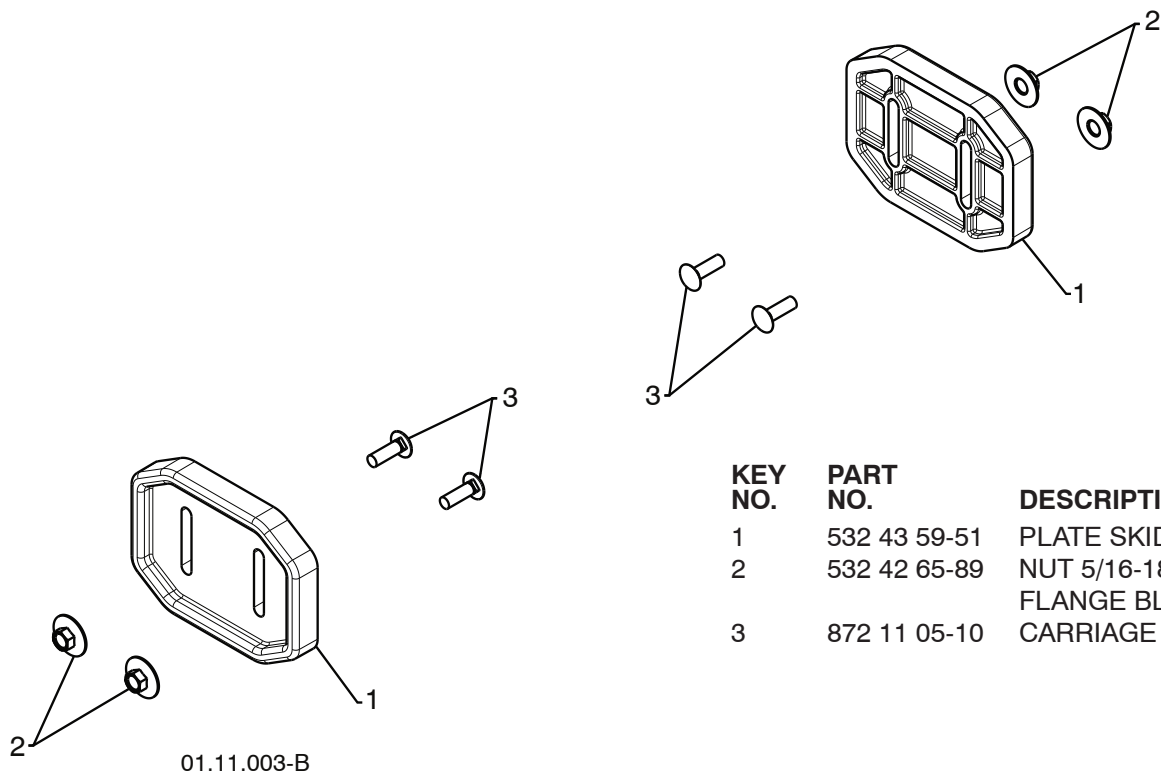

KEY NO.	PART NO.	DESCRIPTION
1	532 43 59-51	PLATE SKID PLASTIC HDPE
2	532 42 65-89	NUT 5/16-18 LARGE HEX FLANGE BLK
3	872 11 05-10	CARRIAGE BOLT 5/16-18 X 1.25

NOTE: All component dimensions given in U.S. inches. 1 inch = 25.4 mm
IMPORTANT: Use only Original Equipment Manufacturer (O.E.M.) replacement parts.
 Failure to do so could be hazardous, damage your snow thrower and void your warranty.

REPAIR PARTS SNOW THROWER - MODEL P14530ES (96198004502)
CONTROL PANEL / DISCHARGE CHUTE

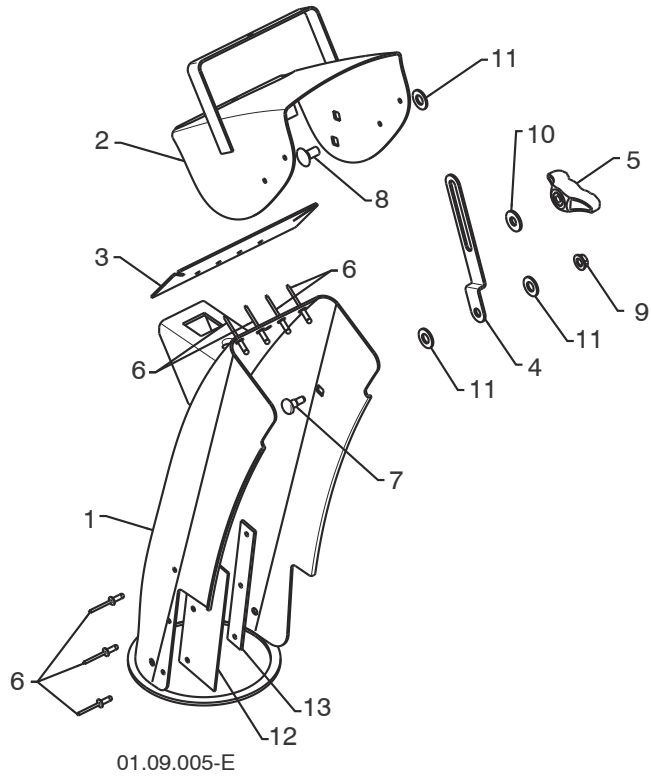

KEY NO.	PART NO.	DESCRIPTION
1	532 44 36-24	CHUTE WELDMENT
2	532 18 45-11	DEFLECTOR WELDMENT
3	532 42 03-25	DEFLECTOR SEAL
4	532 18 41-14	STRAP
5	532 19 19-38	KNOB BLACK
6	532 12 84-15	POP RIVET
7	532 18 56-00	SHOULDER BOLT 1/4-20 X .704
8	872 27 05-05	CARRIAGE BOLT 5/16-18 X .625
9	532 19 17-30	NUT 1/4-20
10	532 15 54-15	WASHER
11	532 17 92-46	PLASTIC WASHER
12	532 43 03-24	CHUTE SNOW SHIELD
13	532 42 17-28	SHIELD RETAINER STRAP

NOTE: All component dimensions given in U.S. inches. 1 inch = 25.4 mm
IMPORTANT: Use only Original Equipment Manufacturer (O.E.M.) replacement parts.
 Failure to do so could be hazardous, damage your snow thrower and void your warranty.

REPAIR PARTS SNOW THROWER - MODEL P14530ES (96198004502)
CONTROL PANEL / DISCHARGE CHUTE

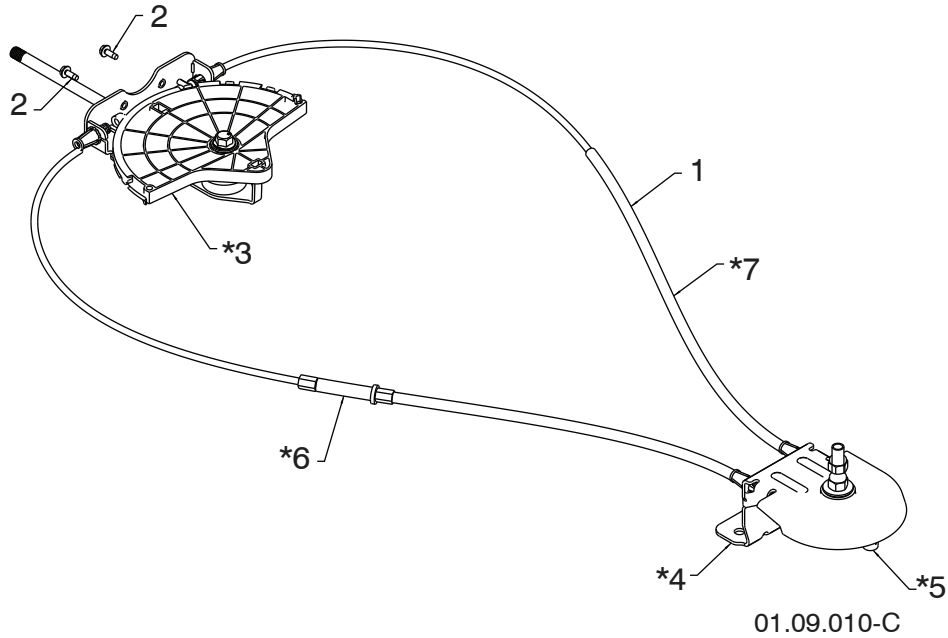

KEY NO.	PART NO.	DESCRIPTION
1	532 42 82-72	LEVER/CABLE ROTATOR ASSEMBLY
2	817 54 10-08	SCREW 10-24 X .625
*3	532 42 06-78	ROTATOR HEAD
*4	532 40 59-32	ROTATOR PIVOT BRACKET
*5	532 42 06-75	PULLEY PIVOT
*6	532 42 82-73	CABLE ASSEMBLY ADJUSTABLE
*7	532 42 83-10	CABLE ASSEMBLY HEAT SHIELD

NOTES:

1. ITEMS INDICATED WITH AN * ARE LISTED AS REFERENCE FOR SERVICE PARTS ONLY.

NOTE: All component dimensions given in U.S. inches. 1 inch = 25.4 mm
IMPORTANT: Use only Original Equipment Manufacturer (O.E.M.) replacement parts.
 Failure to do so could be hazardous, damage your snow thrower and void your warranty.

REPAIR PARTS HANDLES

SNOW THROWER - MODEL P14530ES (96198004502)

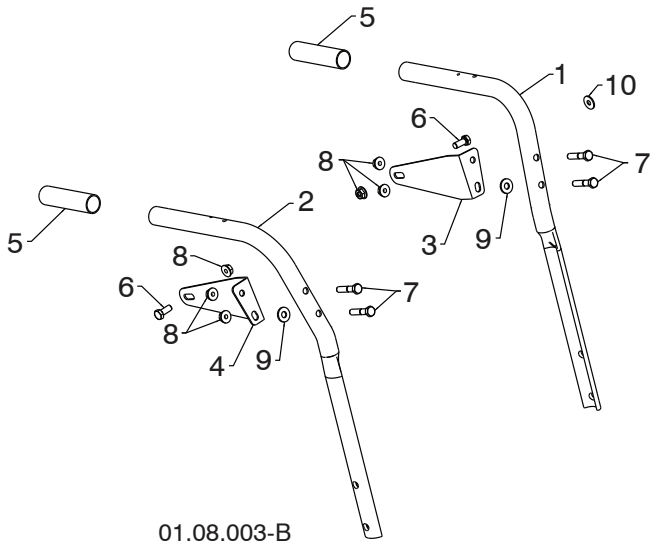

KEY NO.	PART NO.	DESCRIPTION
1	532 42 10-69	PLOW HANDLE LH
2	532 42 10-70	PLOW HANDLE RH
3	532 42 91-48	PANEL BRACKET LH
4	532 42 91-49	PANEL BRACKET RH
5	532 19 95-13	HANDLE GRIP
6	874 78 05-12	SCREW 5/16-18 X .750
7	874 78 05-24	SCREW 5/16-18 X 1.50
8	532 75 11-53	NUT 5/16-18
9	532 15 54-15	WASHER
10	532 05 38-47	WASHER

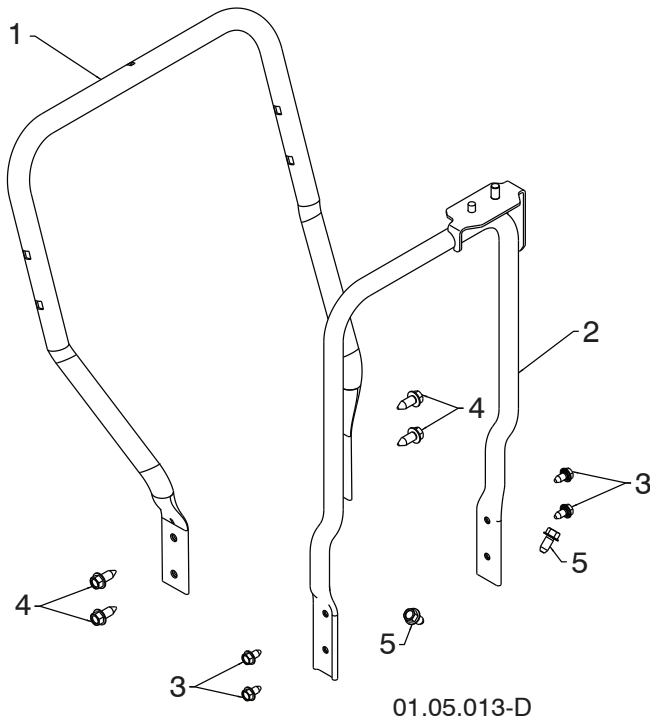

KEY NO.	PART NO.	DESCRIPTION
1	585 23 81-02	LOWER HANDLE
2	532 44 36-17	PIVOT SUPPORT WELDMENT
3	817 00 05-10	SCREW 5/16-18 X .750
4	817 00 06-16	SCREW 3/8-16 X 1.00
5	817 00 06-12	SCREW 3/8-16 X .750

NOTE: All component dimensions given in U.S. inches. 1 inch = 25.4 mm
IMPORTANT: Use only Original Equipment Manufacturer (O.E.M.) replacement parts.
 Failure to do so could be hazardous, damage your snow thrower and void your warranty.

REPAIR PARTS HANDLES

SNOW THROWER - MODEL P14530ES (96198004502)

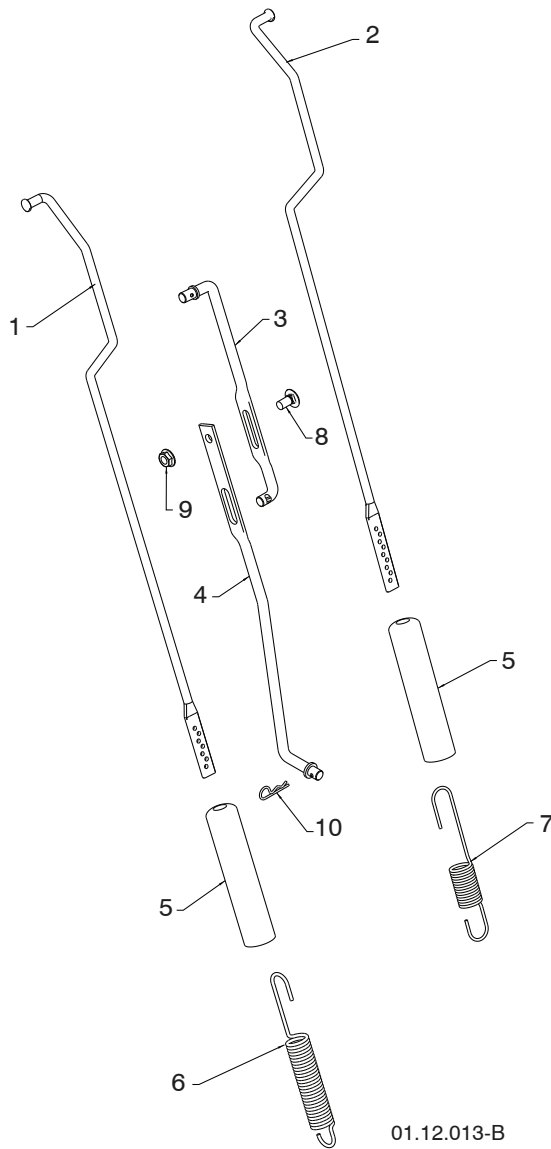

KEY NO.	PART NO.	DESCRIPTION
1	584 80 87-01	IMPELLER ROD ASSEMBLY
2	584 80 88-01	TRACTION ROD ASSEMBLY
3	532 18 04-45	SHIFTER ROD TOP
4	532 18 77-16	SHIFTER ROD BOTTOM
5	532 18 04-47	SPRING SLEEVE
6	580 79 62-01	SPRING CONTROL ROD
7	580 80 21-01	SPRING TRACTION ROD
8	872 27 05-05	CARRIAGE BOLT 5/16-18 X .750
9	532 15 53-77	NUT 5/16-18
10	532 16 96-75	RETAINER

01.12.013-B

NOTE: All component dimensions given in U.S. inches. 1 inch = 25.4 mm
IMPORTANT: Use only Original Equipment Manufacturer (O.E.M.) replacement parts.
 Failure to do so could be hazardous, damage your snow thrower and void your warranty.

**REPAIR PARTS
HANDLES**

SNOW THROWER - MODEL P14530ES (96198004502)

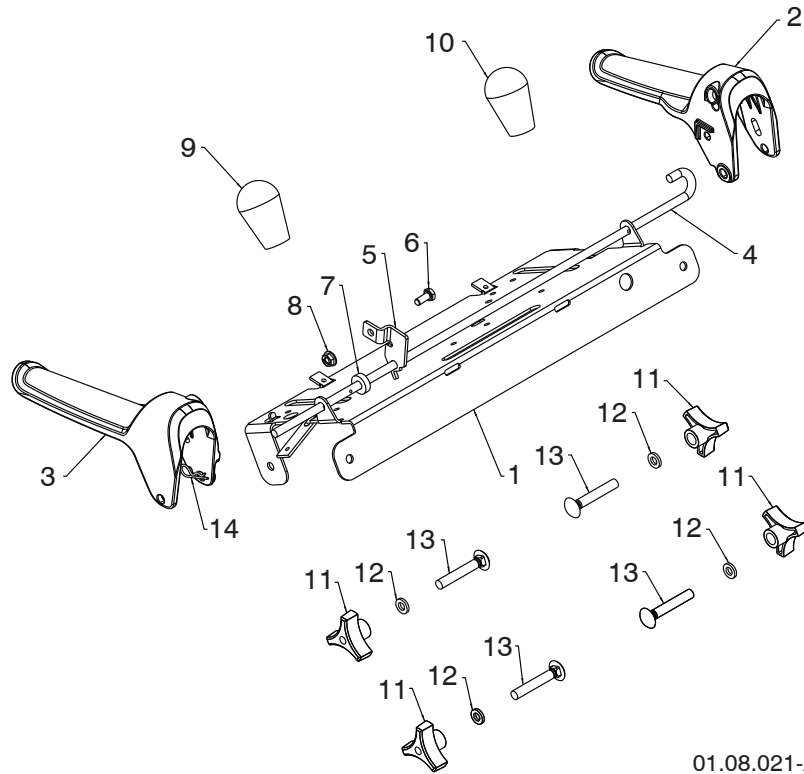

01.08.021-A

KEY NO.	PART NO.	DESCRIPTION
1	585 19 88-02	CONTROL PANEL
2	581 77 98-01	LH CONTROL LEVER
3	581 77 97-01	RH CONTROL LEVER
4	584 80 90-01	INTERLOCK CONTROL ROD
5	585 00 47-01	INTERLOCK BRACKET
6	874 78 04-10	1/4-20 X .625 HEX HEAD SCREW
7	532 42 16-13	SPACER
8	532 08 83-49	1/4-20 FLANGE NUT (TOP LOCK)
9	532 41 42-81	KNOB RED
10	532 41 42-80	KNOB BLACK
11	532 17 88-99	HANDLE KNOB
12	819 13 13-16	3/8 WASHER
13	872 12 06-18	CARRIAGE BOLT 3/8-16 X 2.25
14	532 16 96-75	RETAINER

NOTE: All component dimensions given in U.S. inches. 1 inch = 25.4 mm
IMPORTANT: Use only Original Equipment Manufacturer (O.E.M.) replacement parts.
 Failure to do so could be hazardous, damage your snow thrower and void your warranty.

REPAIR PARTS HANDLES

SNOW THROWER - MODEL P14530ES (96198004502)

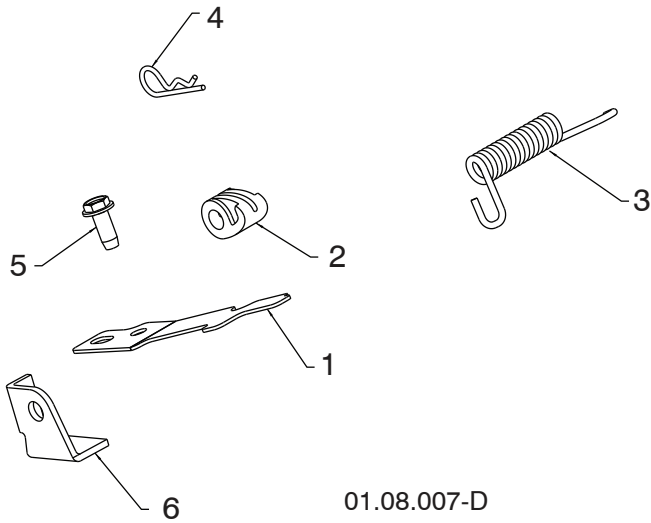

01.08.007-D

KEY NO.	PART NO.	DESCRIPTION
1	532 41 62-88	INTERLOCK SPRING
2	532 44 52-91	INTERLOCK CAM
3	532 44 32-15	TORSION SPRING
4	532 16 96-75	RETAINER
5	817 06 04-10	SCREW 1/4-20 X .625
6	532 42 18-14	INTERLOCK STOP

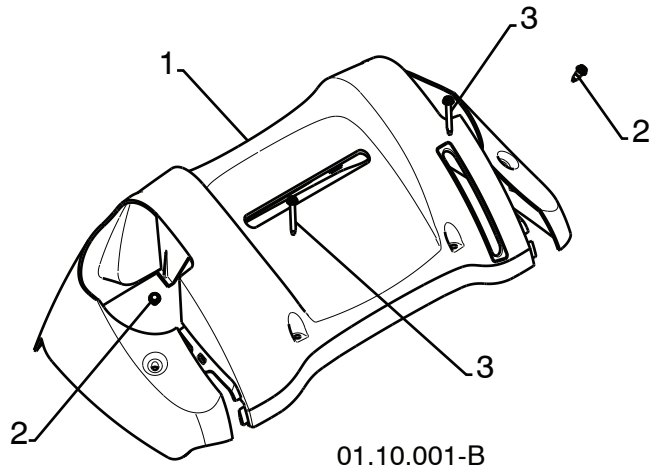

01.10.001-B

KEY NO.	PART NO.	DESCRIPTION
1	532 18 33-52	CONSOLE PANEL
2	532 18 44-71	SCREW 10-24 X .625
3	532 17 52-62	SCREW 10-24 X 1.25

NOTE: All component dimensions given in U.S. inches. 1 inch = 25.4 mm
IMPORTANT: Use only Original Equipment Manufacturer (O.E.M.) replacement parts.
 Failure to do so could be hazardous, damage your snow thrower and void your warranty.

REPAIR PARTS
DRIVE

SNOW THROWER - MODEL P14530ES (96198004502)

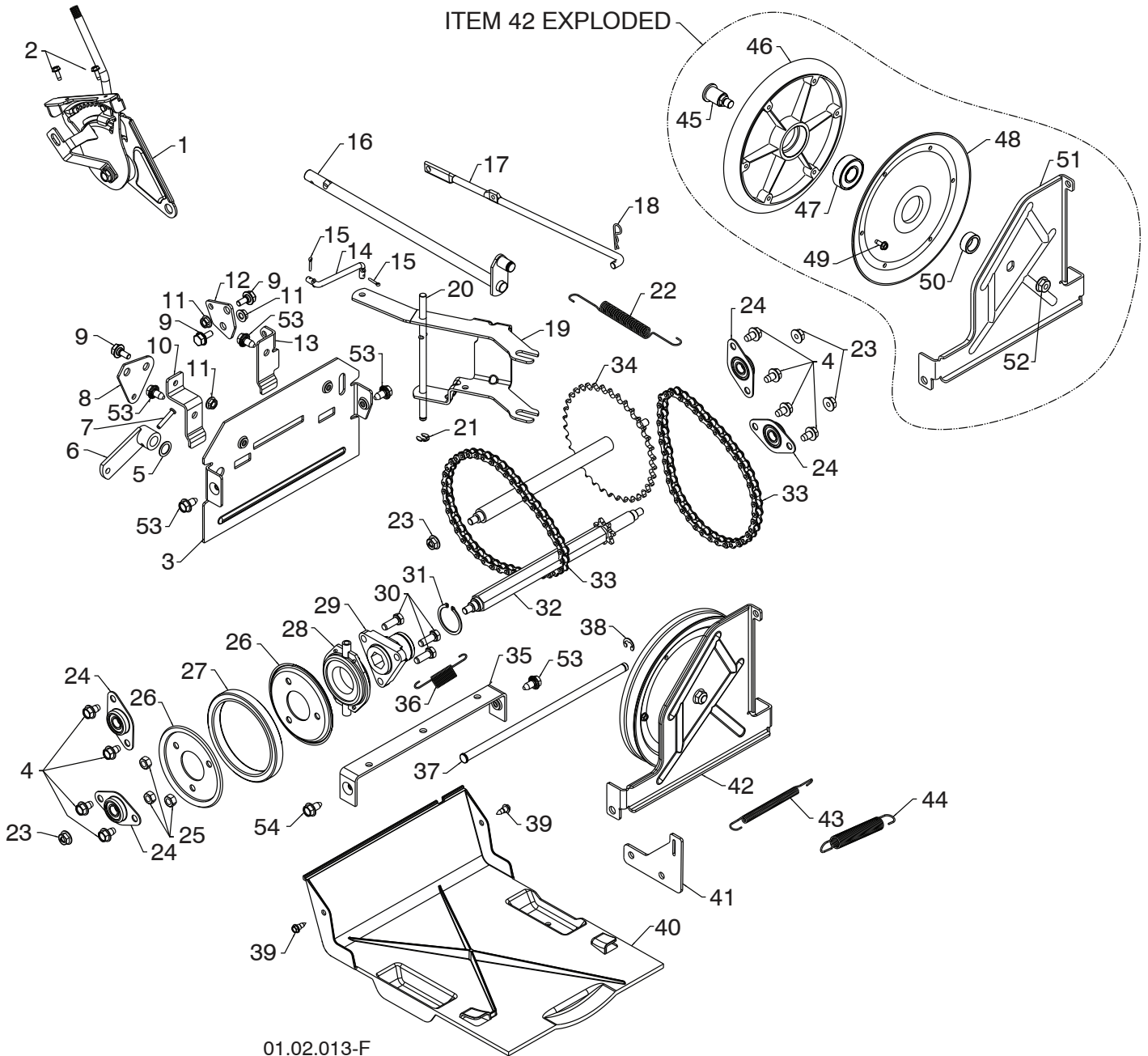

NOTE: All component dimensions given in U.S. inches. 1 inch = 25.4 mm
IMPORTANT: Use only Original Equipment Manufacturer (O.E.M.) replacement parts.
 Failure to do so could be hazardous, damage your snow thrower and void your warranty.

REPAIR PARTS DRIVE

SNOW THROWER - MODEL P14530ES (96198004502)

KEY NO.	PART NO.	DESCRIPTION	KEY NO.	PART NO.	DESCRIPTION
1	532 19 88-75	SPEED SELECTOR ASSEMBLY	28	532 17 53-44	BEARING
2	817 54 10-08	THRED ROLLING SCREW 10-24 X .500	29	532 17 86-13	WHEEL HUB
3	532 41 54-31	END PLATE	30	874 76 05-14	SCREW 5/16-18-.875
4	817 49 05-08	SCREW 5/16-18 X .50	31	812 00 00-12	RETAINER RING
5	532 05 70-79	WASHER	32	532 40 21-87	SPROCKET SHAFT
6	532 40 54-85	CONTROL ARM	33	532 40 16-19	CHAIN
7	532 19 85-80	CLEVIS PIN	34	532 43 73-03	SPROCKET WELDMENT
8	532 41 54-50	SHIFTER PLATE	35	532 41 54-29	SHIFTER BRACKET
9	532 40 28-81	SHOULDER BOLT	36	532 18 01-35	SPRING
10	532 41 54-33	SHIFTER BRACKET	37	532 40 26-52	PLATE PIVOT ROD
11	532 19 17-30	NUT 1/4-20	38	532 42 82-88	E-RING .375
12	532 41 54-35	CLUTCH PLATE	39	532 18 44-71	SHOULDER SCREW
13	532 41 68-64	CLUTCH BRACKET	40	532 41 08-77	BOTTOM PAN
14	532 18 71-01	SHIFTER LINK	41	532 41 66-82	SPRING BRACKET
15	532 70 02-79	RETAINER	42	532 40 26-89	DRIVE PLATE ASSEMBLY
16	532 42 75-42	CONTROL SHAFT	43	532 41 45-57	IDLER SPRING
17	532 40 25-68	CLUTCH ROD	44	532 17 88-28	IDLER SPRING
18	532 16 96-75	RETAINER	45	532 40 25-04	PULLEY SHAFT
19	581 42 25-01	SHIFTER YOKE	46	532 40 18-20	DRIVE PLATE
20	532 40 23-10	PIVOT ROD	47	532 19 87-91	BEARING
21	812 00 00-36	RETAINER	48	532 40 23-93	PULLEY HALF
22	532 40 28-78	RETURN SPRING	49	817 54 10-08	SCREW 10-24 X .50
23	532 75 11-53	NUT 5/16-18	50	532 40 25-11	SPACER BEARING
24	532 40 89-81	BEARING	51	532 42 29-41	SWING PLATE
25	873 93 05-00	NUT 5/16-18	52	532 13 20-10	NUT 3/8-16
26	532 19 95-09	RUBBER WHEEL PLATE	53	532 42 88-67	SCREW 5/16-18 X .750
27	585 02 10-01	RUBBER RING	54	817 00 05-10	BOLT 5/16-18 X .625

NOTE: All component dimensions given in U.S. inches. 1 inch = 25.4 mm

IMPORTANT: Use only Original Equipment Manufacturer (O.E.M.) replacement parts. Failure to do so could be hazardous, damage your snow thrower and void your warranty.

**REPAIR PARTS
DRIVE**

SNOW THROWER - MODEL P14530ES (96198004502)

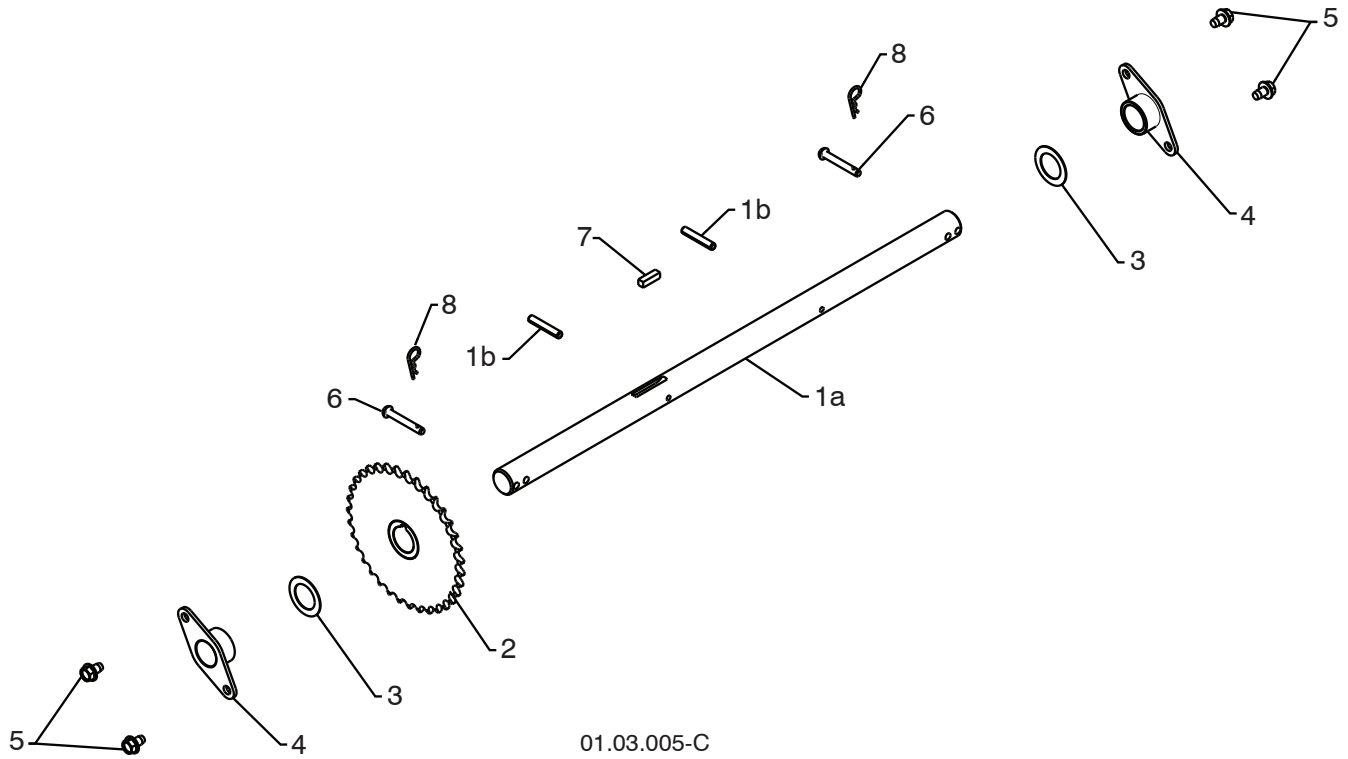

01.03.005-C

KEY NO.	PART NO.	DESCRIPTION
1	532 18 82-26	AXLE ASSEMBLY (assy of 1a,1b)
1a	532 17 93-52	AXLE SHAFT
1b	532 18 42-06	ROLL PIN 3/16
2	532 40 26-91	SPROCKET
3	532 44 49-49	THRUST WASHER
4	532 17 98-30	BEARING
5	817 49 05-08	BOLT 5/16-18 X .500
6	532 17 12-71	PIN
7	532 18 92-82	SQUARE KEY
8	532 12 47-88	RETAINER PIN

NOTE: All component dimensions given in U.S. inches. 1 inch = 25.4 mm
IMPORTANT: Use only Original Equipment Manufacturer (O.E.M.) replacement parts.
 Failure to do so could be hazardous, damage your snow thrower and void your warranty.

REPAIR PARTS

SNOW THROWER - MODEL P14530ES (96198004502)

CHASSIS / ENGINE / PULLEYS

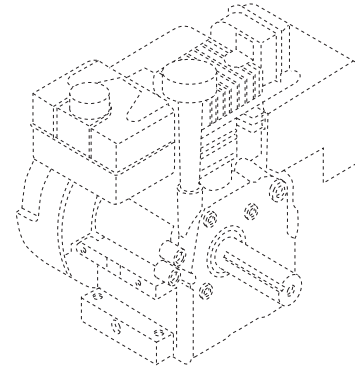
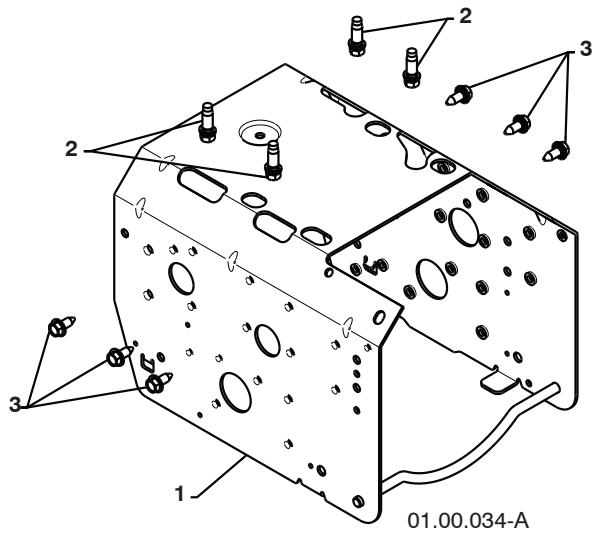

KEY NO.	PART NO.	DESCRIPTION
--	580 42 61-01	LCT COMPLETE ENGINE PW2HK19850781DE
1	532 42 92-75	FRAME
2	532 15 04-06	BOLT 3/8-16
3	532 42 88-67	SCREW 5/16-18 X .750

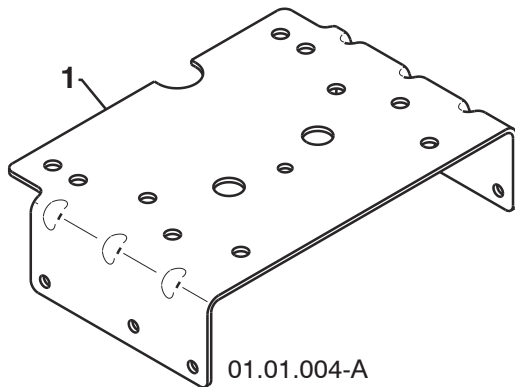

KEY NO.	PART NO.	DESCRIPTION
1	532 43 07-64	ENGINE MOUNTING PLATE

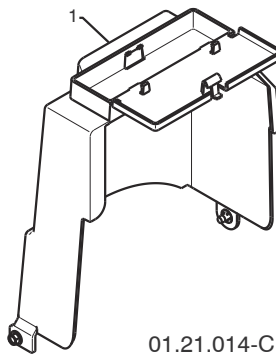

KEY NO.	PART NO.	DESCRIPTION
1	532 42 86-85	COVER ASSEMBLY

NOTE: All component dimensions given in U.S. inches. 1 inch = 25.4 mm
IMPORTANT: Use only Original Equipment Manufacturer (O.E.M.) replacement parts. Failure to do so could be hazardous, damage your snow thrower and void your warranty.

REPAIR PARTS

SNOW THROWER - MODEL P14530ES (96198004502)

CHASSIS / ENGINE / PULLEYS

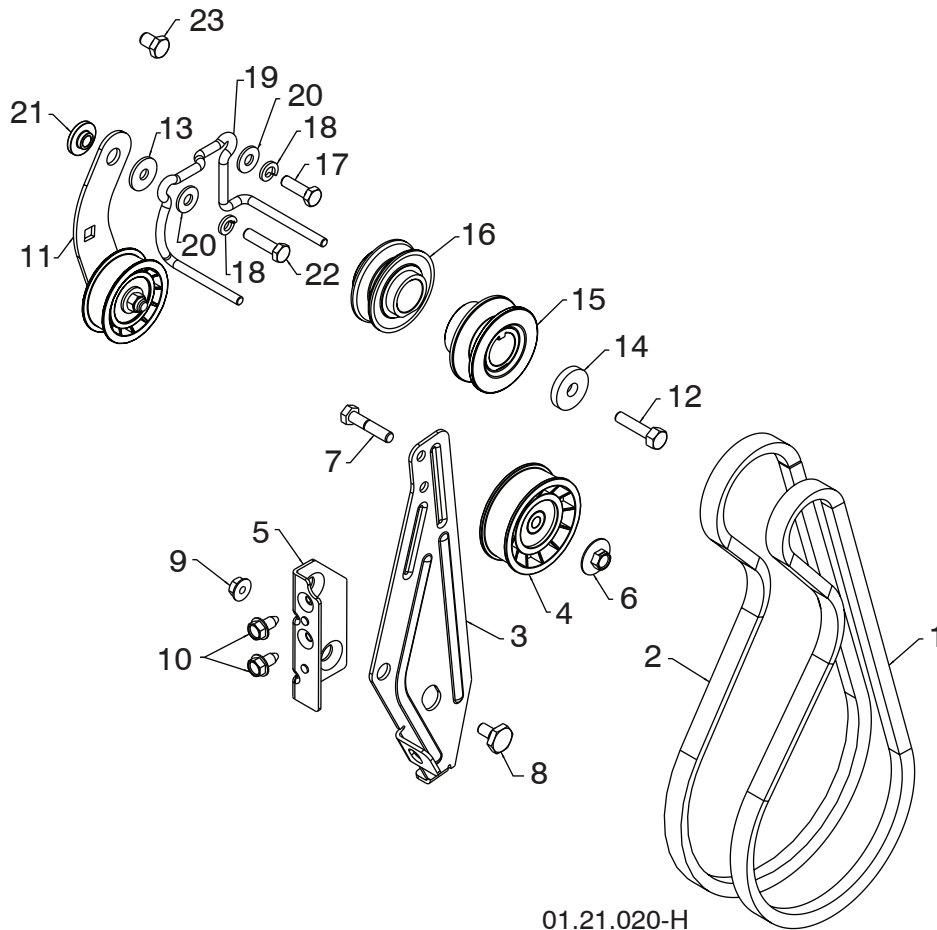

01.21.020-H

KEY NO.	PART NO.	DESCRIPTION	KEY NO.	PART NO.	DESCRIPTION
1	532 43 07-84	IMPELLER BELT	12	532 85 10-84	SCREW 3/8-24 X 1.375
2	532 42 73-04	TRACTION BELT	13	532 05 92-89	WASHER
3	584 23 24-02	IDLER ARM BRACKET	14	819 13 20-05	WASHER
4	532 18 05-23	IDLER PULLEY	15	585 20 02-01	PULLEY ENG IMPELLER
5	532 42 39-90	IDLER BRACKET	16	585 02 93-01	PULLEY ENG TRACTION
6	532 42 65-89	NUT 5/16-18	17	874 61 05-16	SCREW 5/16-24 X 1.00
7	874 78 05-24	SCREW 5/16-18 X 1.50	18	810 04 05-00	LOCKWASHER 5/16
8	532 42 42-97	SHOULDER BOLT 5/16-18 X .50	19	585 05 82-01	BELT GUIDE
9	532 75 11-53	NUT 5/16-18 LOCK	20	532 15 54-15	WASHER 5/16
10	817 00 05-10	SCREW 5/16-18 HEX	21	532 17 53-31	IDLER BUSHING
11	585 23 84-01	TRACTION IDLER BRACKET ASM	22	874 61 05-20	SCREW 5/16-24 X 1.25
			23	874 76 06-08	SCREW 3/8-16 X .500

NOTE: All component dimensions given in U.S. inches. 1 inch = 25.4 mm

IMPORTANT: Use only Original Equipment Manufacturer (O.E.M.) replacement parts. Failure to do so could be hazardous, damage your snow thrower and void your warranty.

**REPAIR PARTS
WHEELS**

SNOW THROWER - MODEL P14530ES (96198004502)

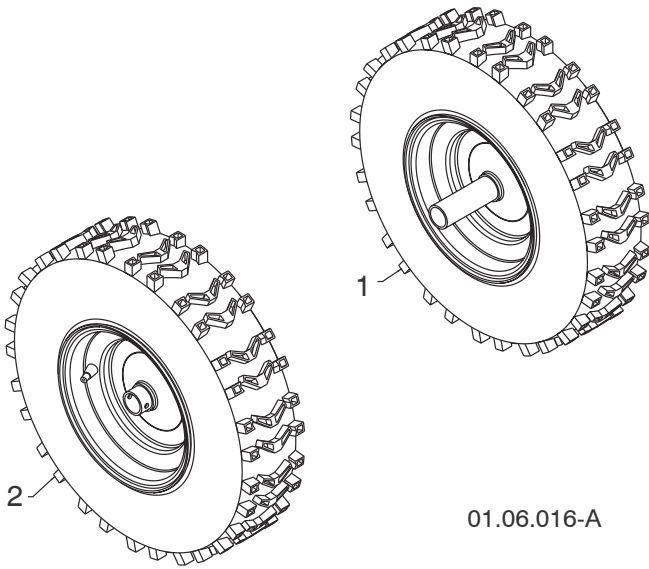

KEY NO.	PART NO.	DESCRIPTION
1	532 44 87-14	WHEEL ASSEMBLY LH
2	532 44 87-15	WHEEL ASSEMBLY RH

01.06.016-A

NOTE: All component dimensions given in U.S. inches. 1 inch = 25.4 mm
IMPORTANT: Use only Original Equipment Manufacturer (O.E.M.) replacement parts.
Failure to do so could be hazardous, damage your snow thrower and void your warranty.

REPAIR PARTS
BAG OF PARTS

SNOW THROWER - MODEL P14530ES (96198004502)

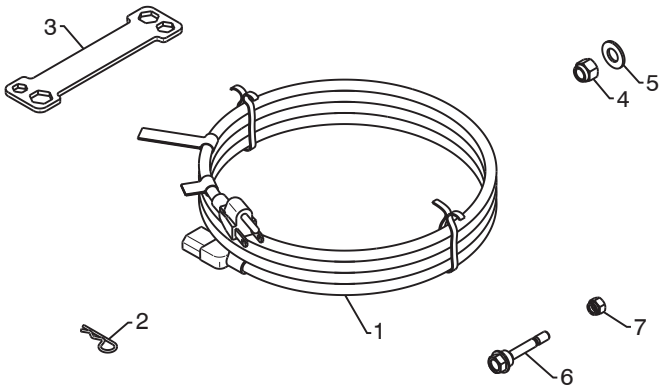

01.14.004-B

KEY NO.	PART NO.	DESCRIPTION
1	532 19 85-63	POWER CORD
2	532 16 96-75	RETAINER PIN
3	532 42 91-12	WRENCH
4	873 80 06-00	LOCKNUT 3/8-16
5	819 13 13-16	WASHER 3/8
6	532 19 20-90	SHEAR BOLT 1/4-20 X 1-3/4
7	873 80 04-00	LOCKNUT 1/4-20

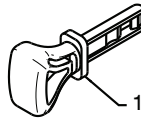

01.14.009-B

KEY NO.	PART NO.	DESCRIPTION
1	532 44 30-59	SAFETY IGNITION KEY KIT

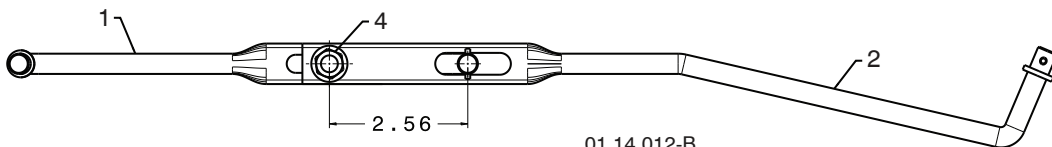
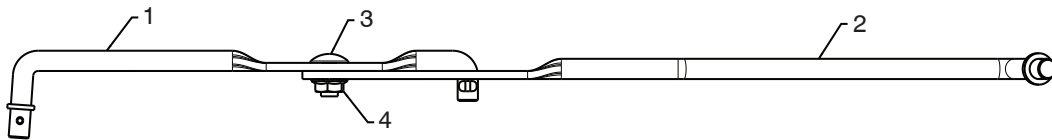

01.14.012-B

KEY NO.	PART NO.	DESCRIPTION
1	532 18 04-45	SHIFTER ROD TOP
2	532 18 77-16	SHIFTER ROD BOTTOM
3	872 27 05-05	CARRIAGE BOLT 5/16-18 X .75
4	532 15 53-77	NUT 5/16-18

NOTE: All component dimensions given in U.S. inches. 1 inch = 25.4 mm
IMPORTANT: Use only Original Equipment Manufacturer (O.E.M.) replacement parts.
 Failure to do so could be hazardous, damage your snow thrower and void your warranty.

**REPAIR PARTS
DECALS**

SNOW THROWER - MODEL P14530ES (96198004502)

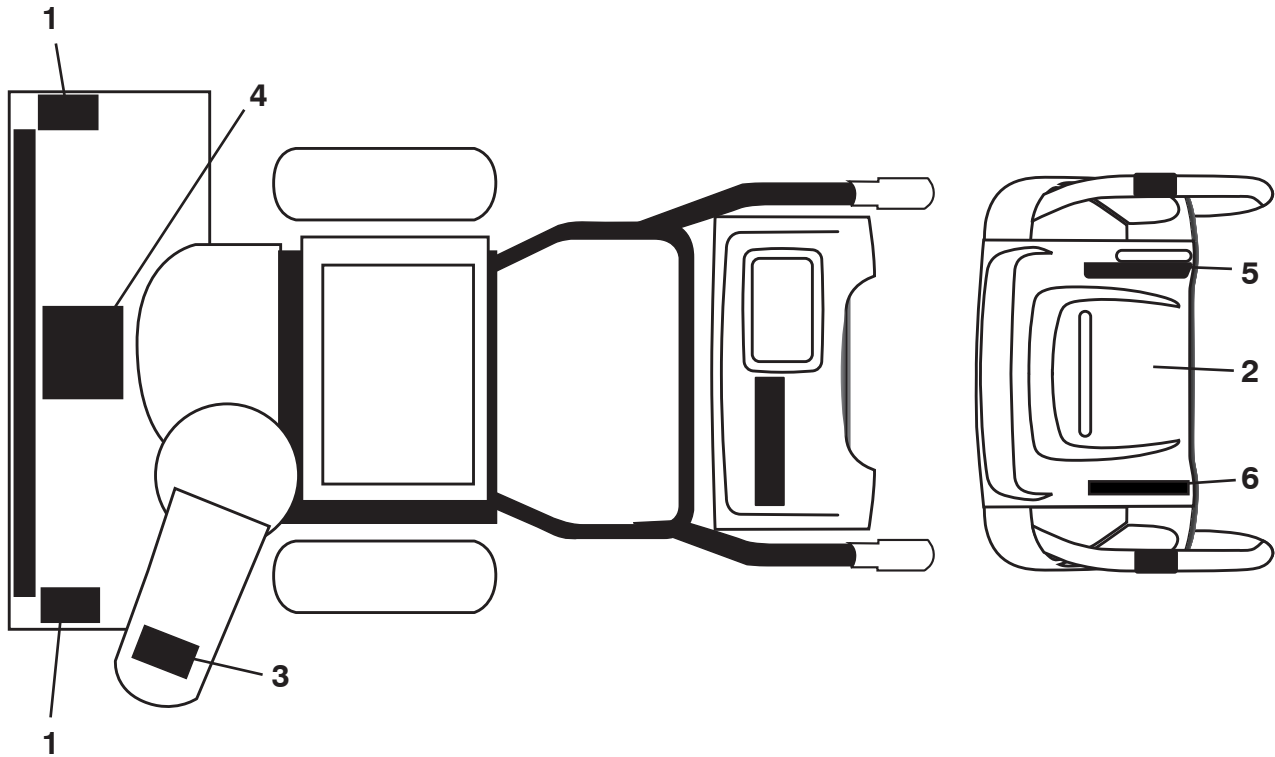

KEY NO.	PART NO.	DESCRIPTION
1	532 18 10-37	DECAL, DANGER
2	532 18 10-33	DECAL, CONSOLE INSTRUCTION E/F
3	532 18 10-35	DECAL, DANGER, DEFLECTOR
4	532 18 10-42	DECAL, DANGER
5	581 43 01-01	DECAL, CONSOLE RT SPEED LEVER POWERSTEERING
6	581 43 01-02	DECAL, CONSOLE LT DEFLECTOR LEVER POWERSTEERING
--	580 92 59-27	OWNER'S MANUAL, ENGLISH
--	580 92 60-32	OWNER'S MANUAL, FRENCH

NOTE: All component dimensions given in U.S. inches. 1 inch = 25.4 mm
IMPORTANT: Use only Original Equipment Manufacturer (O.E.M.) replacement parts.
 Failure to do so could be hazardous, damage your snow thrower and void your warranty.

SERVICE NOTES

SERVICE NOTES

LIMITED WARRANTY

The Manufacturer warrants to the original consumer purchaser that this product as manufactured is free from defects in materials and workmanship. For a period of two (2) years from date of purchase by the original consumer purchaser, we will repair or replace, at our option, without charge for parts or labor incurred in replacing parts, any part which we find to be defective due to materials or workmanship. This Warranty is subject to the following limitations and exclusions.

1. This warranty does not apply to the engine, transaxle/transmission components, battery (except as noted below) or components parts thereof. Please refer to the applicable manufacturer's warranty on these items.
2. Transportation charges for the movement of any power equipment unit or attachment are the responsibility of the purchaser. Transportation charges for any parts submitted for replacement under this warranty must be paid by the purchaser unless such return is requested by the manufacturer.
3. Battery Warranty: On products equipped with a Battery, we will replace, without charge to you, any battery which we find to be defective in manufacture, during the first ninety (90) days of ownership. After ninety (90) days, we will exchange the Battery, charging you 1/12 of the price of a new Battery for each full month from the date of the original sale. Battery must be maintained in accordance with the instructions furnished.
4. The Warranty period for any products used for rental or commercial purposes is limited to 90 days from the date of original purchase.
5. This Warranty applies only to products which have been properly assembled, adjusted, operated, and maintained in accordance with the instructions furnished. This Warranty does not apply to any product which has been subjected to alteration, misuse, abuse, improper assembly or installation, delivery damage, or to normal wear of the product.
6. Exclusions: Excluded from this Warranty are belts, blades, blade adapters, normal wear, normal adjustments, standard hardware and normal maintenance.
7. In the event you have a claim under this Warranty, you must return the product to an authorized service dealer.

Should you have any unanswered questions concerning this Warranty, please contact:

HOP
Outdoor Products Customer Service Dept.
9335 Harris Corners Parkway
Charlotte, NC 28269 USA

In Canada contact:
HOP
5855 Terry Fox Way
Mississauga, Ontario
L5V 3E4

giving the model number, serial number and date of purchase of your product and the name and address of the authorized dealer from whom it was purchased.

THIS WARRANTY DOES NOT APPLY TO INCIDENTAL OR CONSEQUENTIAL DAMAGES AND ANY IMPLIED WARRANTIES ARE LIMITED TO THE SAME TIME PERIODS STATED HEREIN FOR OUR EXPRESSED WARRANTIES. Some areas do not allow the limitation of consequential damages or limitations of how long an implied Warranty may last, so the above limitations or exclusions may not apply to you. This Warranty gives you specific legal rights, and you may have other rights which vary from locale to locale.

This is a limited Warranty within the meaning of that term as defined in the Magnuson-Moss Act of 1975.

Poulan