

Poulan

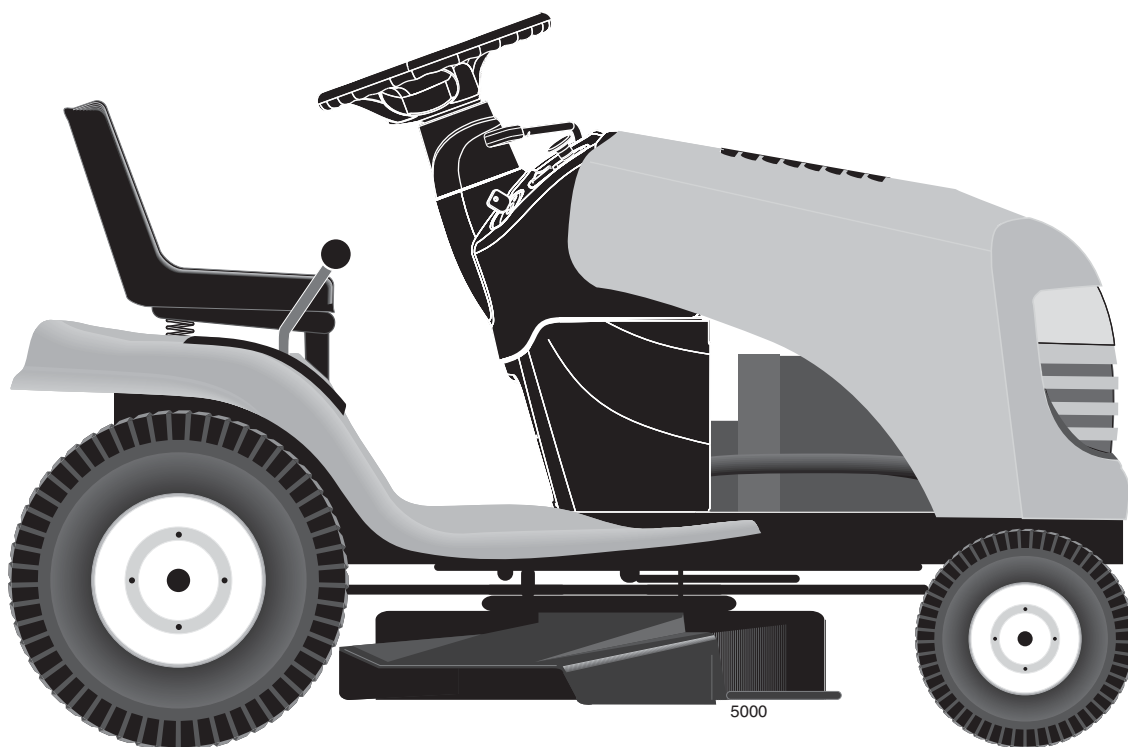

REPAIR PARTS MANUAL

MODEL:

PO175A42LT

LAWN TRACTOR

ALWAYS WEAR EYE PROTECTION DURING OPERATION

Visit our website: www.poulan.com



WARNING:

Read this Manual and follow all Warnings and Safety Instructions. Failure to do so can result in serious injury.

HOW TO USE THIS MANUAL

This manual is designed to provide the customer with a means to identify the parts on his/her tractor when ordering repair parts. The illustrations may or may not represent the actual assemblies; therefore, it is not recommended to use this manual as a guide to assemble or disassemble the tractor. Some hardware and parts are drawn larger in order to more readily identify them.

Each tractor has its own model number.

The model number for your tractor can be found on the fender under the seat.

When ordering parts, always give the following information:

- Product - "Tractor"
- MODEL NUMBER - "PO175A42LT (96048002400)"
- Part Number
- Part Description

TABLE OF CONTENTS

SCHEMATIC	3
ELECTRICAL.....	4-5
CHASSIS	6-7
DRIVE.....	8-9
ENGINE.....	10-11
STEERING	12-13
MOWER DECK	14-15
MOWER LIFT.....	16
SEAT	17
DECALS.....	18
PARTS AND SERVICE.....	20

TRACTOR - MODEL NO. PO175A42LT (96048002400), PRODUCT NO. 960 48 00-24 SCHEMATIC

SCH11

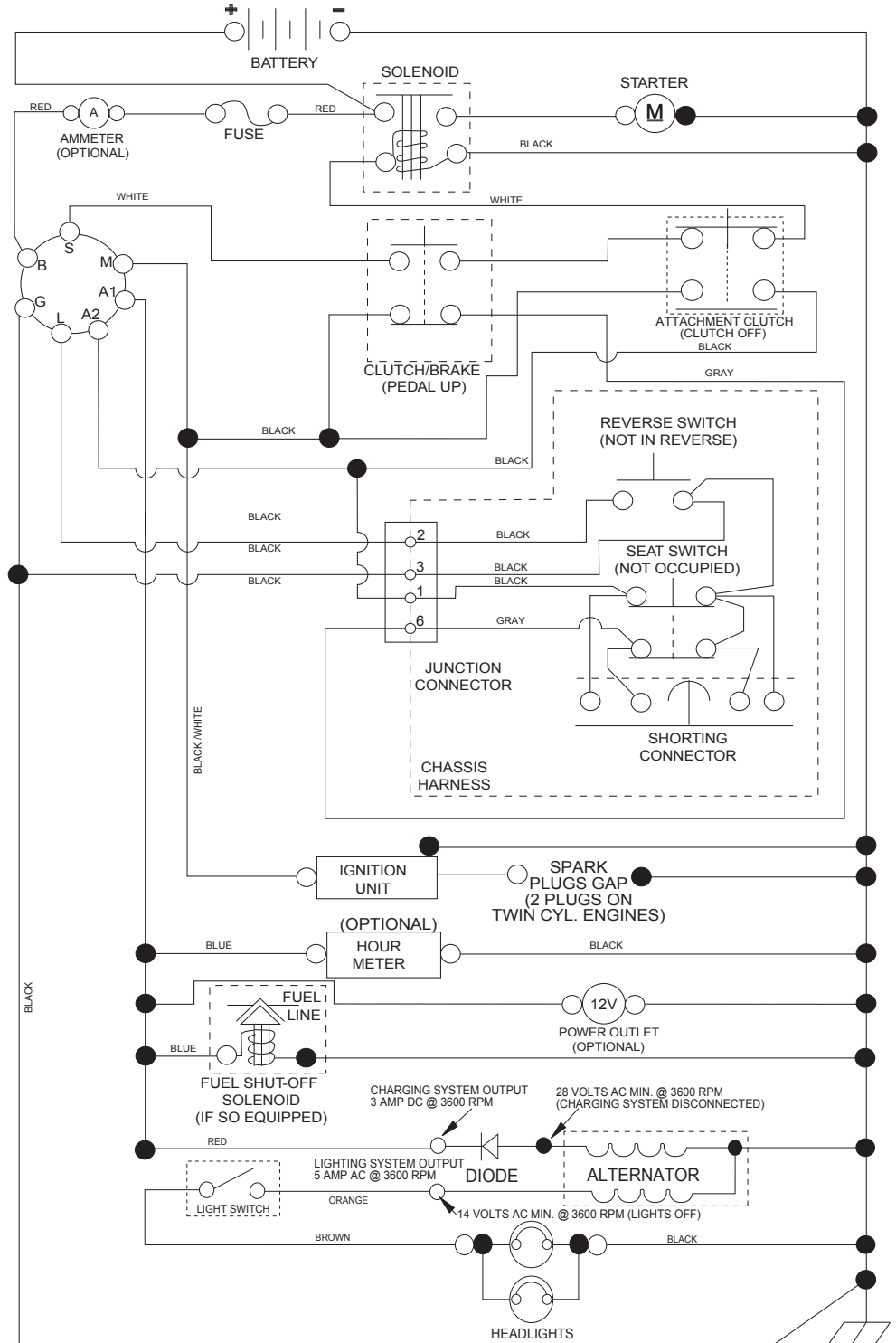

NOTE
YOUR TRACTOR IS EQUIPPED WITH A SPECIAL ALTERNATOR SYSTEM. THE LIGHTS ARE NOT CONNECTED TO THE BATTERY, BUT HAVE THEIR OWN ELECTRICAL SOURCE. BECAUSE OF THIS, THE BRIGHTNESS OF THE LIGHTS WILL CHANGE WITH ENGINE SPEED. AT IDLE THE LIGHTS WILL DIM. AS THE ENGINE IS SPEEDED UP, THE LIGHTS WILL BECOME THEIR BRIGHTEST.

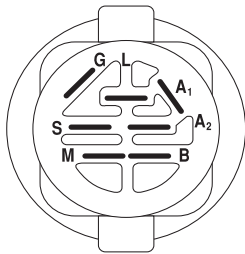

IGNITION SWITCH

POSITION	CIRCUIT "MAKE"
OFF	M+G+A1
RUN/OVERRIDE	B+A1
RUN	B+A1 L+A2
START	B + S + A1

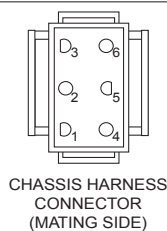

WIRING INSULATED CLIPS
NOTE: IF WIRING INSULATED CLIPS WERE REMOVED FOR SERVICING OF UNIT, THEY SHOULD BE RE-INSTALLED TO PROPERLY SECURE YOUR WIRING.

NON-REMOVABLE CONNECTIONS

REMOVABLE CONNECTIONS

TRACTOR - MODEL NO. PO175A42LT (96048002400), PRODUCT NO. 960 48 00-24
ELECTRICAL

T06S

With 12V Outlet Option

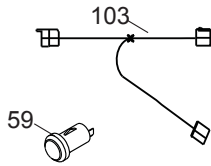

With Service Minder Option

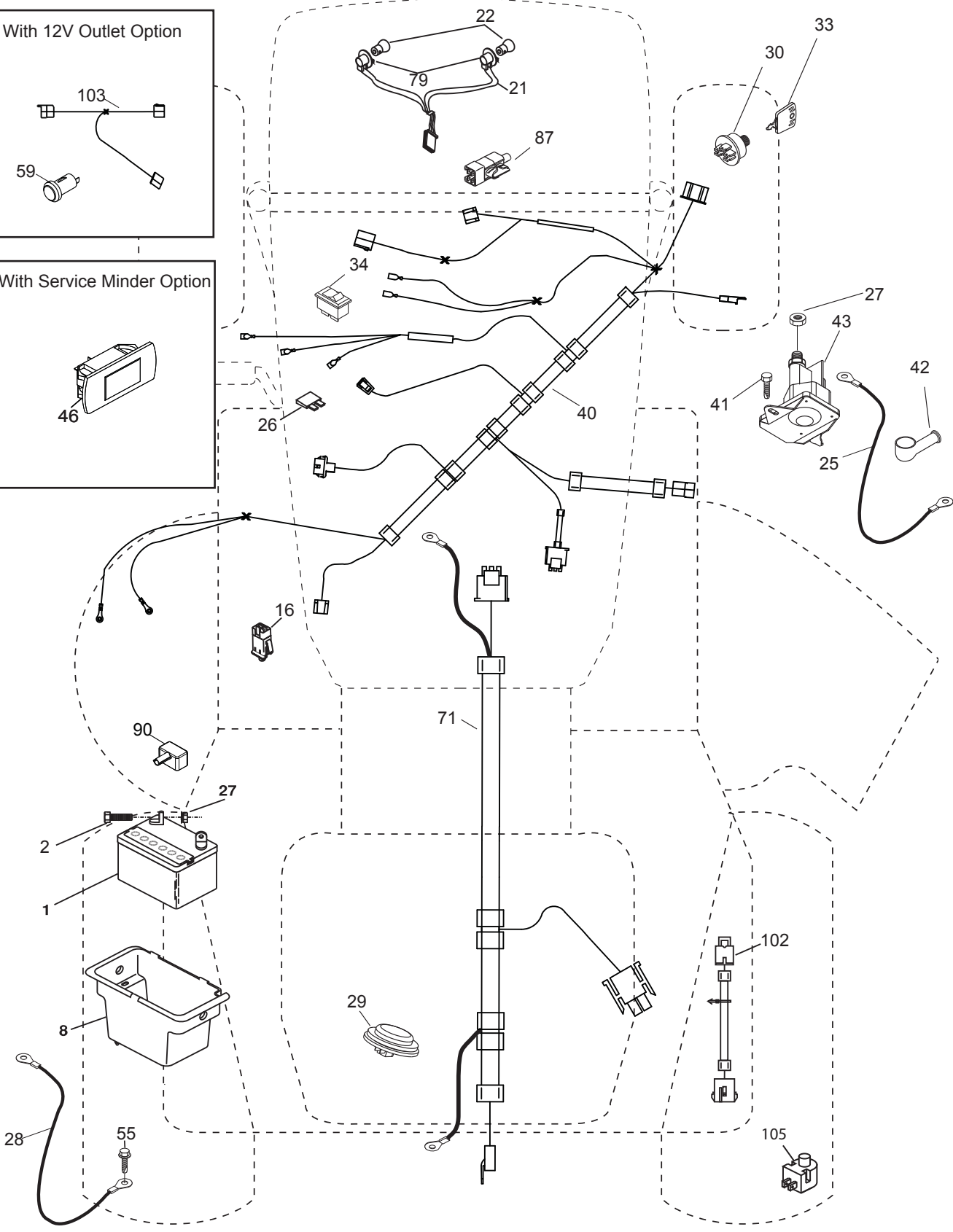
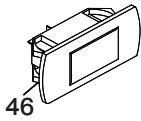

**TRACTOR - MODEL NO. PO175A42LT (96048002400), PRODUCT NO. 960 48 00-24
ELECTRICAL**

KEY NO.	PART NO.	DESCRIPTION
1	532 16 34-65	Battery
2	874 76 04-12	Bolt Hex Hd 1/4-20 unc x 3/4
8	532 19 32-28	Box Battery
16	532 17 61-38	Switch Interlock
21	532 17 56-88	Harness Socket Light
22	532 00 41-52	Bulb, Light #1156
25	532 41 28-94	Cable Starter 6 Ga. BL/Red 14.5
26	532 17 51-58	Fuse
27	873 51 04-00	Nut Keps Hex 1/4-20 unc
28	532 19 88-85	Cable Ground 18" Rear Battery Blk 6 Ga.
29	532 19 27-49	Switch Seat
30	532 19 33-50	Switch Ign
33	532 41 19-35	Key/Chain
34	532 11 07-12	Switch Light/Reset
40	532 40 10-98	Harness Ign
41	817 72 04-08	Screw 1/4-20 unc x 1/2
42	532 13 15-63	Cover Terminal Red
43	532 19 25-07	Solenoid
55	817 06 05-12	Screw 5/16-18 x 3/4
71	532 44 15-44	Harness Ign. Chass.
79	532 17 52-42	Socket Asm. Bulb
87	532 19 78-02	Switch Interlock Clutch
90	532 43 53-95	Cover Terminal
102	532 41 97-81	Pigtail Rev. GT Vatr.
105	532 40 75-68	Switch Reverse

NOTE: All component dimensions given in U.S. inches
1 inch = 25.4 mm

**TRACTOR - MODEL NO. PO175A42LT (96048002400), PRODUCT NO. 960 48 00-24
CHASSIS**

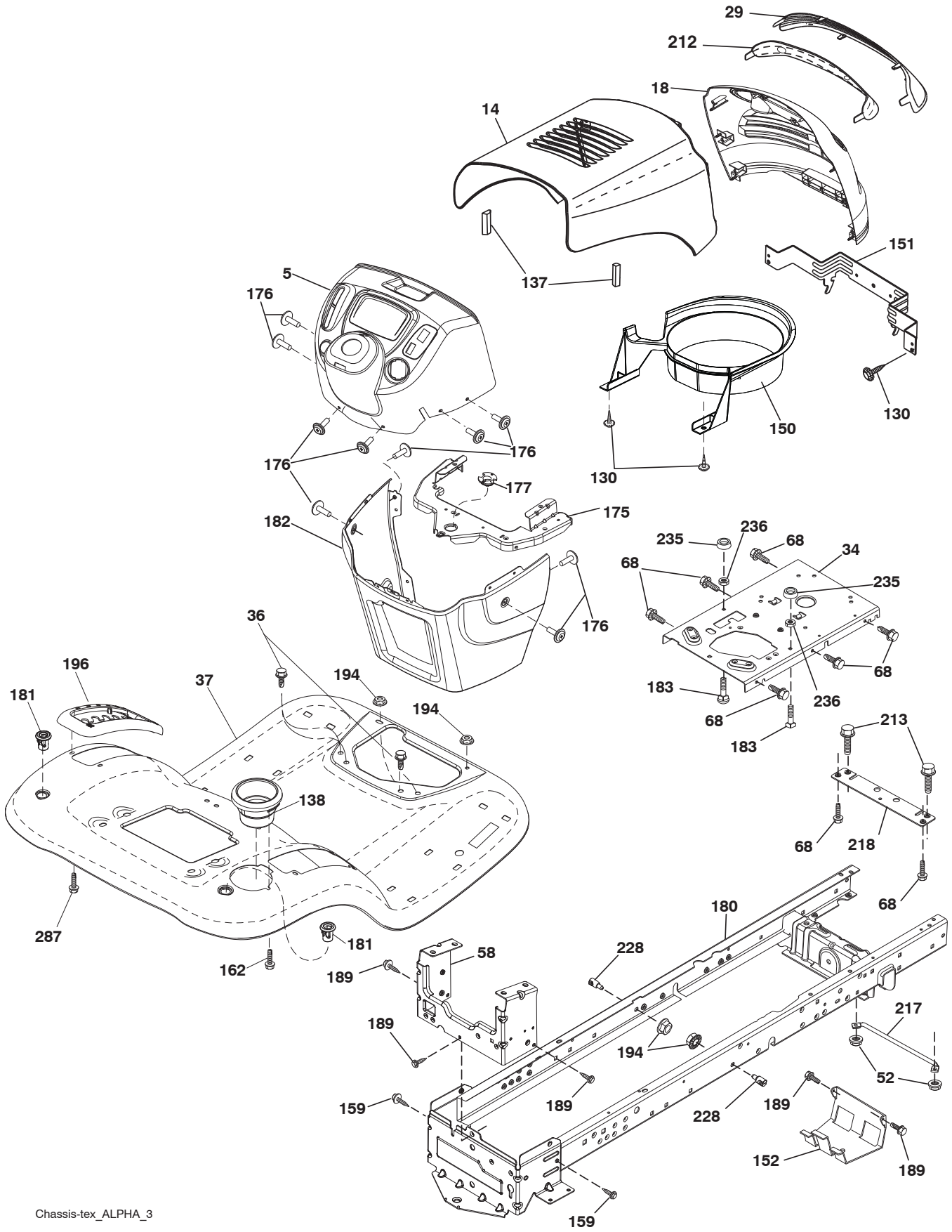

**TRACTOR - MODEL NO. PO175A42LT (96048002400), PRODUCT NO. 960 48 00-24
CHASSIS**

KEY NO.	PART NO.	DESCRIPTION
5	532 41 17-64	Dash
14	532 40 61-79	Hood
18	532 42 67-41	Grille
29	532 18 75-69	Insert Reflective
34	532 19 61-25	Plate Engine
36	817 06 05-12	Screw 5/16-18 x 3/4
37	532 42 09-86	Fender
52	873 68 05-00	Nut Crown Lock 5/16-18
58	532 41 22-80	Drawbar Upper
68	817 49 05-08	Screw Thdrol. 5/16-18 x 1/2
130	532 41 63-58	Screw #10 x 0.750
137	532 18 49-21	Bumper Hood
138	532 40 97-30	Cupholder
150	532 18 44-61	Duct Intake Air
151	532 18 75-68	Bracket Pivot
152	532 19 95-35	Shield Browning
159	817 00 06-12	Screw 3/8-16 x 3/4
162	532 14 24-32	Screw 1/4 x 1/2
175	532 19 32-43	Crossmember
176	532 40 07-76	Screw 10-24 x 5/8
177	532 19 52-28	Bushing Steering
180	532 41 50-63	Chassis
181	532 40 30-25	Bushing Mtg. Fender Crgo.
182	532 19 30-57	Dash Lower
183	874 52 05-20	Bolt 5/16-18 x 1-1/4
189	817 00 05-12	Screw 5/16-18 x 3/4
194	873 90 05-00	Nut Lock Hex Flange 5/16-18
196	532 41 45-79	Console Asm. Deck Lift
212	532 19 54-02	Lens Bar
213	874 76 05-12	Bolt Hex Hd. 5/16-18 unc x 3/4
217	532 40 91-67	Rod Pivot Hood
218	532 19 63-95	X-Piece Hood Stop
228	532 19 51-61	Stud Fastener
235	532 40 61-29	Spacer Fender
236	873 93 05-00	Nut Lock 5/16-18
287	817 60 04-06	Screw 1/4-20 x 3/8

NOTE: All component dimensions given in U.S. inches
1 inch = 25.4 mm

TRACTOR - MODEL NO. PO175A42LT (96048002400), PRODUCT NO. 960 48 00-24
DRIVE

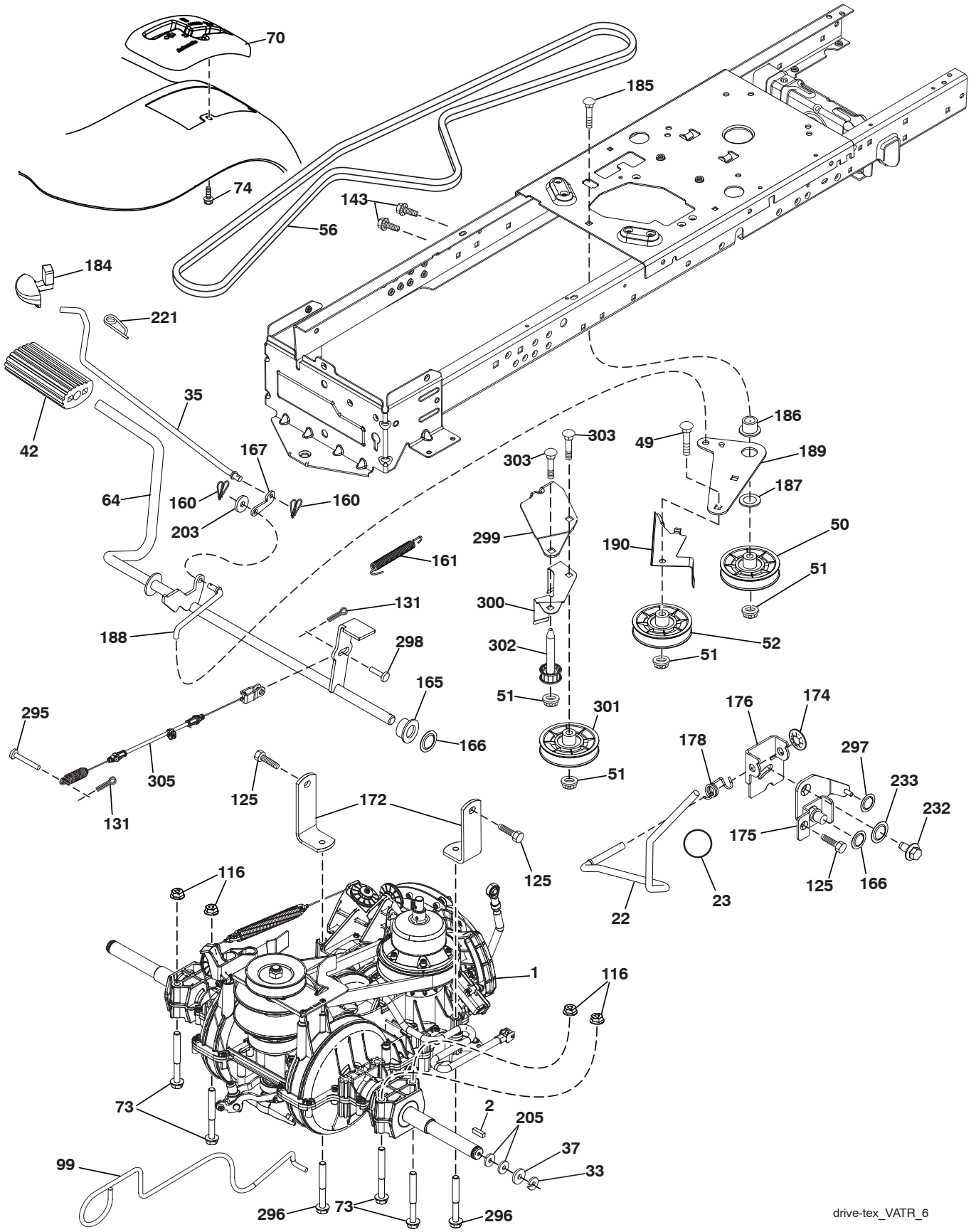

drive-tex_VATR_6

TRACTOR - MODEL NO. PO175A42LT (96048002400), PRODUCT NO. 960 48 00-24 DRIVE

KEY NO.	PART NO.	DESCRIPTION	KEY NO.	PART NO.	DESCRIPTION
1	-----	Transmission, Gentrans (415663) (Order parts from transaxle manufacturer.)	175	532 41 56-77	Shaft Asm Shift
2	532 12 35-83	Key.Square .2.0 x .1845/.1865	176	532 19 62-14	Arm.Clevis.Rod.Shift
22	532 42 10-63	Rod Shift	178	532 19 74-56	Spring.Shift.Gt.2006
23	532 10 69-33	Knob	184	532 44 15-04	Handle.Parking Brake
33	812 00 00-01	E-Ring. #5133-75	185	872 11 06-22	Bolt.Rdhd.3/8-16Unc x 2-3/4 Gr.5
35	532 19 77-22	Rod.Brake.Parking. Lt.Tex	186	532 19 43-21	Spacer.Retainer
37	532 12 17-49	Washer.25/32 X 1 1/4 x 16 Ga.	187	819 13 32-10	Washer.13/32 x 2 x 10 Ga.
42	532 12 48-72	Cover.Pedal.Blk.Round	188	532 19 43-23	Link.Clutch.Ground Drive
49	872 11 06-14	Bolt.Rdhd.3/8-16Uncx1-3/4.Gr 5	189	532 19 43-17	Bellcrank.Grounddrive.Nstg/Nstl
50	532 19 43-27	Idler.Flat.910"Offset	190	532 19 43-18	Keeper.Bellcrank.Drive.Ground
51	873 90 06-00	Nut, Hex, Flangelock 3/8-16	203	819 11 11-16	Washer 11/32 x 11/16 x 16 Ga.
52	532 19 43-26	Idler.V-Groove.Offset	205	532 12 17-48	Washer.25/32 x 1-5/8 x 16Ga.
56	532 19 72-53	Belt.Drive.100.97"	221	532 40 31-87	Retainer.Spring.Clip.Handle
64	532 19 62-00	Shaft Asm.Pedal.Brake Control	232	874 78 07-16	Bolt.Fin Hex.7/16-14 x 1 Gr5
70	532 44 03-23	Console	233	532 40 52-96	Washer.Serrated
73	874 49 05-44	Bolt.Hex.Flghd.5/16-18.Gr.5	295	532 42 03-06	Pin Clevis 183 Od x 1.260 Long
74	532 14 24-32	Screw.Hex.Wsh.Hi-Lo.1/4x1/2unc	296	532 42 04-71	Screw Thdrol 5/16-18 x 3
99	532 42 73-40	Rod Bypass	297	532 42 02-23	Nut Push 1/4
116	873 90 05-00	Nut, Lock Hex Flange 5/16-18 unc	298	532 41 56-94	Pin Clevis Cbl. Brk. Variator
125	817 00 05-12	Screw.5/16-18x3/4.Smgml.Tap/Bl	299	532 41 56-83	Bracket Mount Idler
131	876 02 03-12	Pin Cotter 3/32/ x 3/4	300	532 41 56-81	Keeper Idler Rear
143	817 49 05-08	Screw.Thdrol.5/16-18 x 1/2 Tytt	301	532 41 56-80	Pulley Idler V-Groove
160	532 16 94-84	Retainer.Clip(M).Dia.290	302	532 41 56-66	Pulley Idler Flat 2.0 Od
161	532 10 57-09	Spring.Return.Clutch.6.75	303	872 11 06-18	Bolt Rdhd Sgnk 3/8-16 x 2-1/4
165	532 19 62-12	Bushing.Shaft.Brake.Hand Contr	305	532 41 56-92	Cable Brake Variator
166	532 42 91-64	Nut Push .625			
167	532 40 52-57	Latch.Brake.Parking			
172	532 41 56-64	Strap Torque LH/RH			
174	532 19 72-89	Nut.Push..500			

NOTE: All component dimensions given in U.S. inches
1 inch = 25.4 mm

**TRACTOR - MODEL NO. PO175A42LT (96048002400), PRODUCT NO. 960 48 00-24
ENGINE**

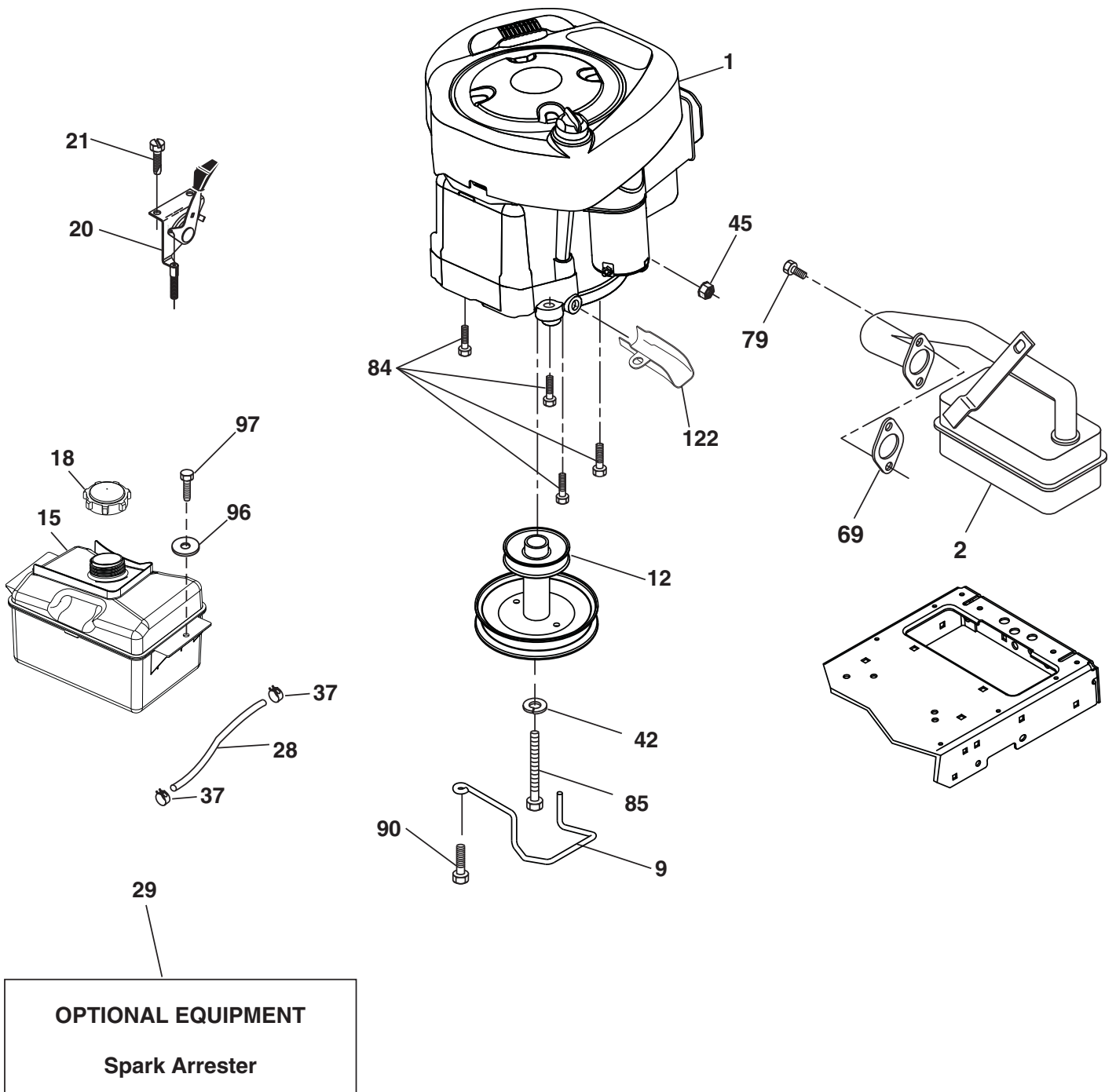

engine-tex_BS_36

TRACTOR - MODEL NO. PO175A42LT (96048002400), PRODUCT NO. 960 48 00-24 ENGINE

KEY NO.	PART NO.	DESCRIPTION
1	-----	Engine, B&S 31C707-3487-G1 (438654) (Order parts from engine manufacturer.)
2	532 13 73-52	Muffler Exhaust B&S
9	532 19 43-19	Keeper Belt
12	532 40 19-85	Pulley Engine
15	532 40 75-45	Tank Fuel Front
18	532 43 02-20	Cap Asm Fuel
20	532 17 05-51	Control Th/ch Flag
21	817 72 04-08	Screw Hex Thd Cut 1/4-20 x 1/2
28	532 40 11-37	Line Fuel
29	532 13 71-80	Kit Spark Arrestor (Flat Scrn)
37	532 12 34-87	Clamp Hose
42	810 04 07-00	Washer Lock 7/16
45	873 51 04-00	Nut Keps Hex 1/4-20 unc
69	532 16 52-91	Gasket Eng 1 313 Id Tin Plated
79	532 19 23-34	Screw Socket Head 5/16-18 x 3/4
84	817 06 06-20	Screw 3/8-16 x 1-1/4
85	532 17 39-37	Bolt Hex 7/16-20 x 4 Gr. 5-1.5 THR
90	817 00 06-16	Screw 3/8-16 x 1
96	819 09 14-16	Washer 9/32 x 7/8 x 16 Ga.
97	817 67 04-12	Screw Thdrol 1/4-20 x 3/4
122	532 42 19-22	Extension Drain Oil

NOTE: All component dimensions given in U.S. inches
1 inch = 25.4 mm

For engine service and replacement parts, call the toll free number for your engine manufacturer listed below:

Briggs & Stratton 1-800-233-3723

Engine Power Rating Information

The gross power rating for individual gas engine models is labeled in accordance with SAE (Society of Automotive Engineers) code J1940 (Small Engine Power & Torque Rating Procedure), and rating performance has been obtained and corrected in accordance with SAE J1995 (Revision 2002-05). Torque values are derived at 3060 RPM; horsepower values are derived at 3600 RPM. Actual gross engine power will be lower and is affected by, among other things, ambient operating conditions and engine-to-engine variability. Given both the wide array of products on which engines are placed and the variety of environmental issues applicable to operating the equipment, the gas engine will not develop the rated gross power when used in a given piece of power equipment (actual "on-site" or net power). This difference is due to a variety of factors including, but not limited to, accessories (air cleaner, exhaust, charging, cooling, carburetor, fuel pump, etc.), application limitations, ambient operating conditions (temperature, humidity, altitude), and engine-to-engine variability. Due to manufacturing and capacity limitations, Briggs & Stratton may substitute an engine of higher rated power for this Series engine.

TRACTOR - MODEL NO. PO175A42LT (96048002400), PRODUCT NO. 960 48 00-24
STEERING ASSEMBLY

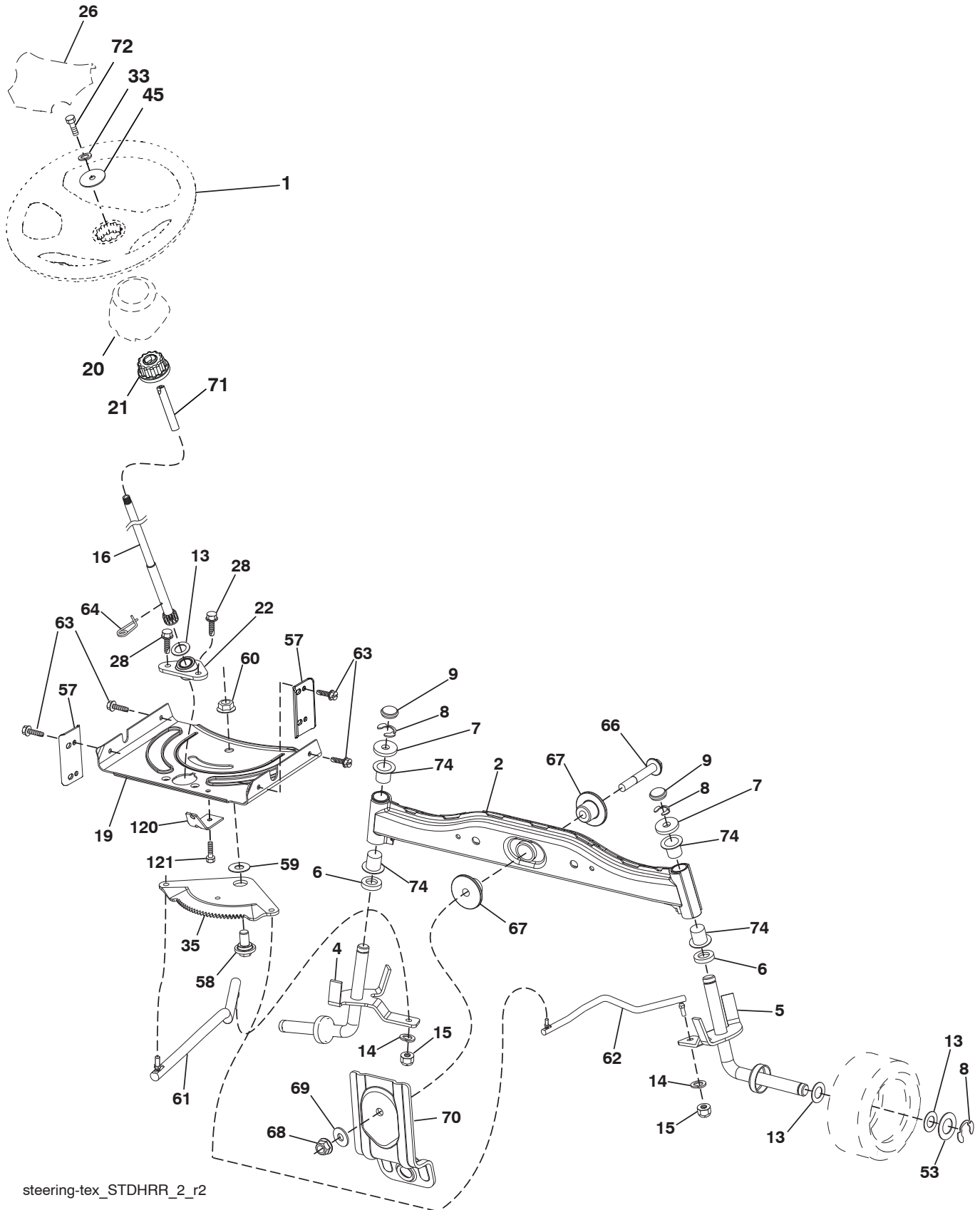

steering-tex_STDHRR_2_r2

**TRACTOR - MODEL NO. PO175A42LT (96048002400), PRODUCT NO. 960 48 00-24
STEERING ASSEMBLY**

KEY NO.	PART NO.	DESCRIPTION
1	532 42 45-43	Wheel, Steering
2	532 41 81-68	Axle Asm., Front
4	532 40 30-87	Spindle Asm., LH
5	532 40 30-88	Spindle Asm., RH
6	532 12 49-31	Washer Thrust 0.75 x 1.23
7	532 12 17-48	Washer 25/32 x 1-5/8 x 16 Ga.
8	812 00 00-29	Ring, Clip #T5304-75
9	532 12 12-32	Cap, Spindle
13	532 12 17-49	Washer 25/32 x 1-1/4 x 16 Ga.
14	810 04 06-00	Washer Lock 3/8
15	873 54 06-00	Nut, Crown Lock 3/8-24 unf
16	532 42 93-74	Shaft Steering
19	532 19 47-29	Plate Steering
20	532 41 12-91	Boot Steering
21	532 18 67-37	Adapter, Wheel Steering
22	532 42 05-37	Strg. Supt. Lower
26	532 42 46-91	Insert, Wheel Steering
28	817 00 06-12	Screw 3/8-16 x 3/4
33	810 04 05-00	Washer Lock 5/16
35	532 19 47-32	Gear, Sector Plate
45	819 11 38-12	Washer 11/32 ID x 2-3/8 OD x 12 Ga.
53	532 18 89-67	Washer Hardened .793 x 1.637 x .060
57	532 40 74-65	Bracket Upstop
58	532 19 47-47	Bolt Shoulder Sector Pivot CFM
59	532 19 47-48	Washer Thrust Sector Steering
60	873 97 10-00	Nut Flange Lock 5/8-11
61	532 19 47-40	Draglink, LH
62	532 19 47-41	Draglink, RH
63	817 00 05-12	Screw 5/16-18 x 3/4
64	532 19 98-49	Retainer Clip Spring Steering
66	871 02 07-48	Bolt Hex Fghd 7/16-14 x 3 Serr
67	532 19 47-37	Bushing PM Front Axle
68	873 90 07-00	Nut Lock Flange 7/16-14 Gr. 5
69	532 19 91-62	Washer 1.5 x .505 x .118
70	532 19 61-97	Bracket Deck Susp. Front
71	532 19 07-52	Shaft Extension Steering
72	532 42 89-82	Bolt Fin Hx 5/16-18 x 4 w/Patch
74	532 12 49-37	Bearing Col. Strg.
120	532 41 56-89	Bracket Locator
121	817 49 05-08	Screw 5/16-18 x 1/2

NOTE: All component dimensions given in U.S. inches
1 inch = 25.4 mm

**TRACTOR - MODEL NO. PO175A42LT (96048002400), PRODUCT NO. 960 48 00-24
MOWER DECK**

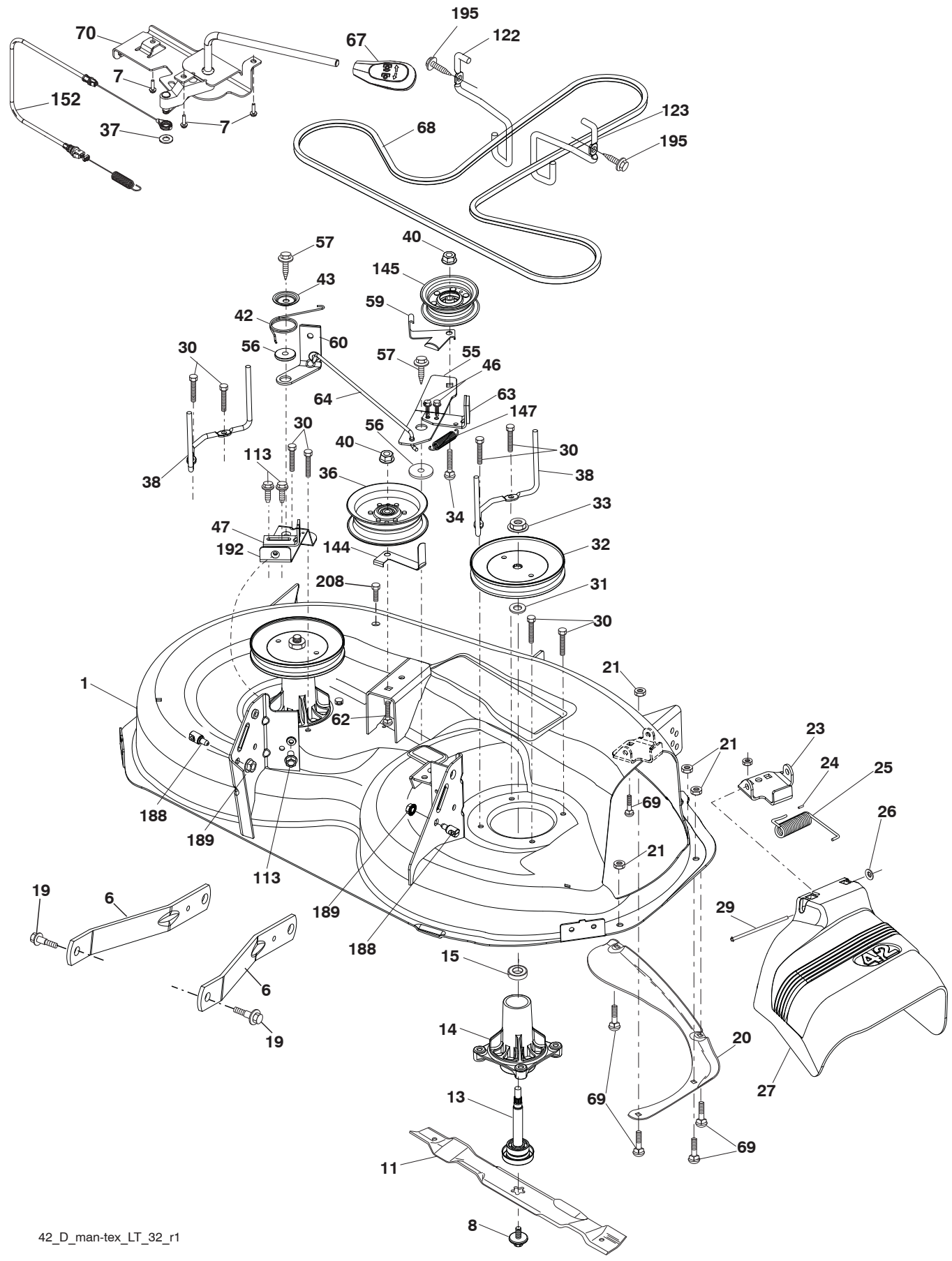

42_D_man-tex_LT_32_r1

**TRACTOR - MODEL NO. PO175A42LT (96048002400), PRODUCT NO. 960 48 00-24
MOWER DECK**

KEY NO.	PART NO.	DESCRIPTION	KEY NO.	PART NO.	DESCRIPTION
1	532 19 99-11	Mower Housing	56	532 19 90-92	Spacer, Retainer
6	532 19 51-86	Arm Suspension	57	817 00 06-16	Screw Hexwsh Thd 3/8-16 x 1
7	532 41 63-58	Screw #10 x 0.750 BOS Thread	59	532 14 10-43	Guard, Tuv Idler (94)
8	532 19 30-03	Bolt/Washer Asm 7/16-20 unf	60	532 19 72-61	Arm Brake Mower
11	532 13 89-71	Blade, 42" Hi-Lift (For bagging or discharge)	62	872 11 06-16	Bolt Rdhd Sqnk 3/8-16 unc x 2
13	532 19 28-72	Shaft Assembly, Mandrel	63	532 19 94-77	Arm Brake Mower
14	532 18 72-81	Housing, Mandrel	64	532 19 97-90	Linkage Brake
15	532 11 04-85	Bearing, Ball, Mandrel	67	532 40 30-12	Handle, Clutch Cable
19	532 19 65-39	Bolt, Shoulder	68	532 42 96-36	V-Belt
20	532 15 97-70	Baffle, Vortex	69	872 14 05-05	Bolt Rdhd Sqnk 5/16-18 x 5/8
21	873 68 05-00	Nut, Crownlock 5/16-18 unc	70	532 19 83-32	Clutch Asm. Manual
23	532 19 25-57	Bracket, Deflector	113	817 00 05-10	Screw 5/16-18
24	532 10 53-04	Cap, Sleeve	122	532 19 72-58	Keeper Belt Eng. LH
25	532 19 70-26	Spring, Torsion, Deflector	123	532 19 72-59	Keeper Belt Eng. RH
26	532 11 04-52	Nut, Push	144	532 19 92-04	Keeper Belt
27	532 40 30-04	Shield, Deflector	145	532 19 31-97	Pulley Idler Primary
29	532 13 14-91	Rod, Hinge	147	532 40 19-71	Spring Return
30	532 17 39-84	Screw Thdrol Rolling Wsh Hd	152	532 43 51-11	Cable Clutch Manual w/Spr.
31	532 18 76-90	Washer, Spacer	188	532 19 51-61	Stud Fastener
32	532 19 74-73	Pulley, Mandrel	189	873 90 05-00	Nut Lock Hex Flange
33	532 40 02-34	Nut, Toplock, Flanged	192	532 19 72-60	Bracket Brake Stand LH
34	872 11 06-12	Bolt Carr Sh. 3/8-16 x 1-1/2 Gr. 5	195	817 00 06-12	Screw Hexwsh Thdr 3/8-16 x 3/4
36	532 19 73-79	Pulley, Idler 4.50 RAW	208	817 67 06-08	Screw Thdrol 3/8-16 x 1/2
37	819 13 13-16	Washer 13/32 x 13/16 x 16 Ga.	--	532 19 28-70	Mandrel Assembly (Includes housing, shaft assembly, and bearing only - pulley/nut/washer and blade bolt/washers not included)
38	532 43 25-20	Keeper Belt Mandrel	--	532 41 52-41	Replacement Mower, Complete
40	873 90 06-00	Nut, Lock Flg. 3/8-16 unc			
42	532 19 84-10	Spring Torsion Brake			
43	532 19 72-56	Spring Torsion Retainer			
46	532 13 77-29	Screw Thd Roll 1/4-20 x 5/8			
47	532 19 72-50	Bracket Clutch Cable			
55	532 43 71-10	Arm, Idler			

NOTE: All component dimensions given in U.S. inches
1 inch = 25.4 mm

**TRACTOR - MODEL NO. PO175A42LT (96048002400), PRODUCT NO. 960 48 00-24
MOWER LIFT**

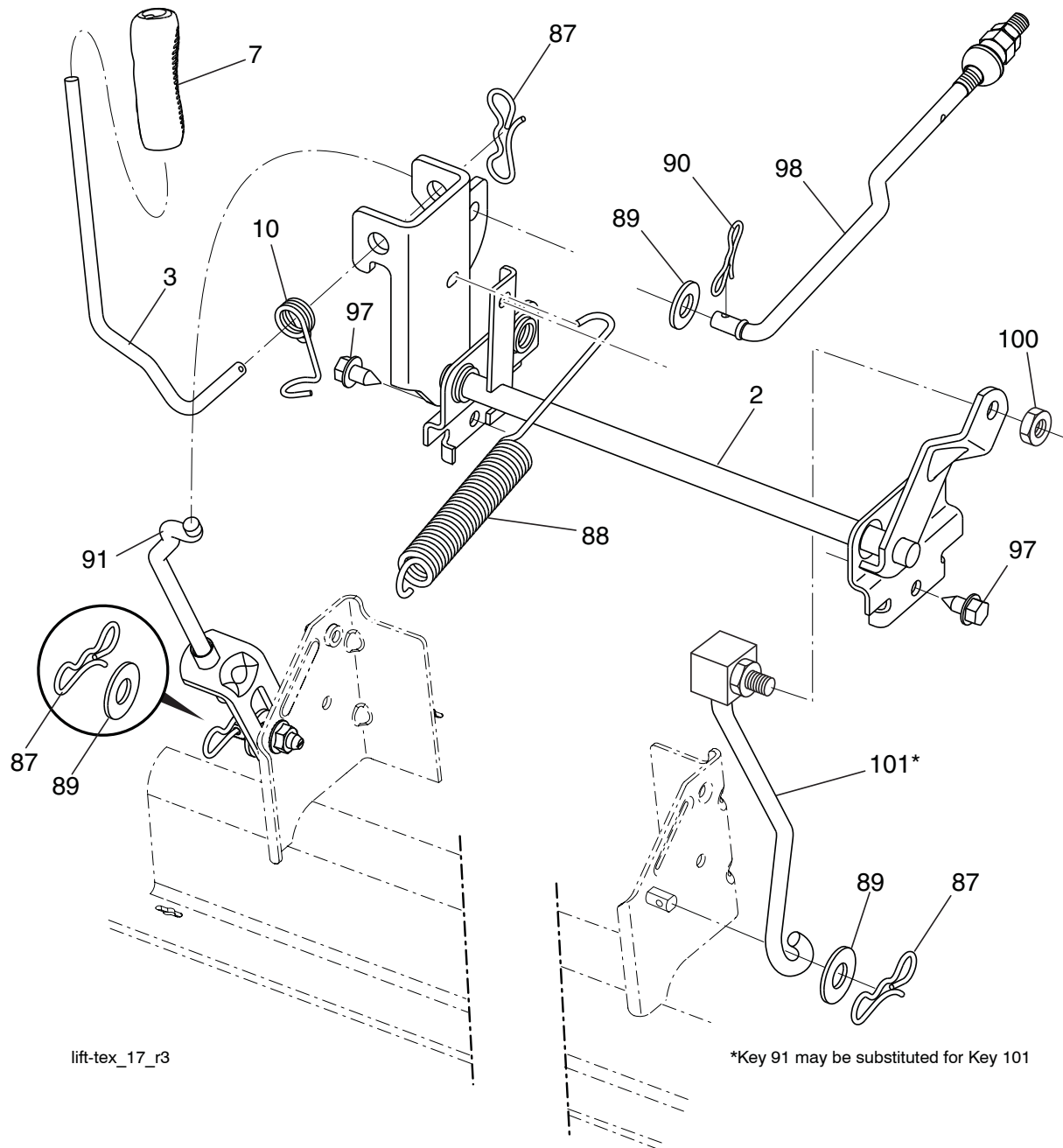

KEY NO.	PART NO.	DESCRIPTION
2	532 42 20-27	Shaft Asm., Cross Lift
3	532 19 52-31	Lever Asm., Lift RH
7	532 41 15-55	Grip, Lever
10	532 19 63-14	Spring Torsion
87	532 19 42-09	Pin Cotter 7/16 Bow Tie Lock
88	532 41 07-10	Spring Lift Assist
89	819 19 19-12	Washer Clear Zinc
90	532 19 42-08	Pin Cotter 5/16 Bow Tie Lock

KEY NO.	PART NO.	DESCRIPTION
91	532 19 51-81	Link Lift Susp Mower Rear
97	817 00 06-12	Screw 3/8-16 x .75 Smgml Tap/R.Z
98	532 19 52-70	Link Lift Susp. Front Mower
100	873 93 06-00	Nut Centerlock 3/8 -16 unc
101	532 40 70-03	Link Asm. Lift Fixed

NOTE: All component dimensions given in U.S. inches
1 inch = 25.4 mm

**TRACTOR - MODEL NO. PO175A42LT (96048002400), PRODUCT NO. 960 48 00-24
SEAT ASSEMBLY**

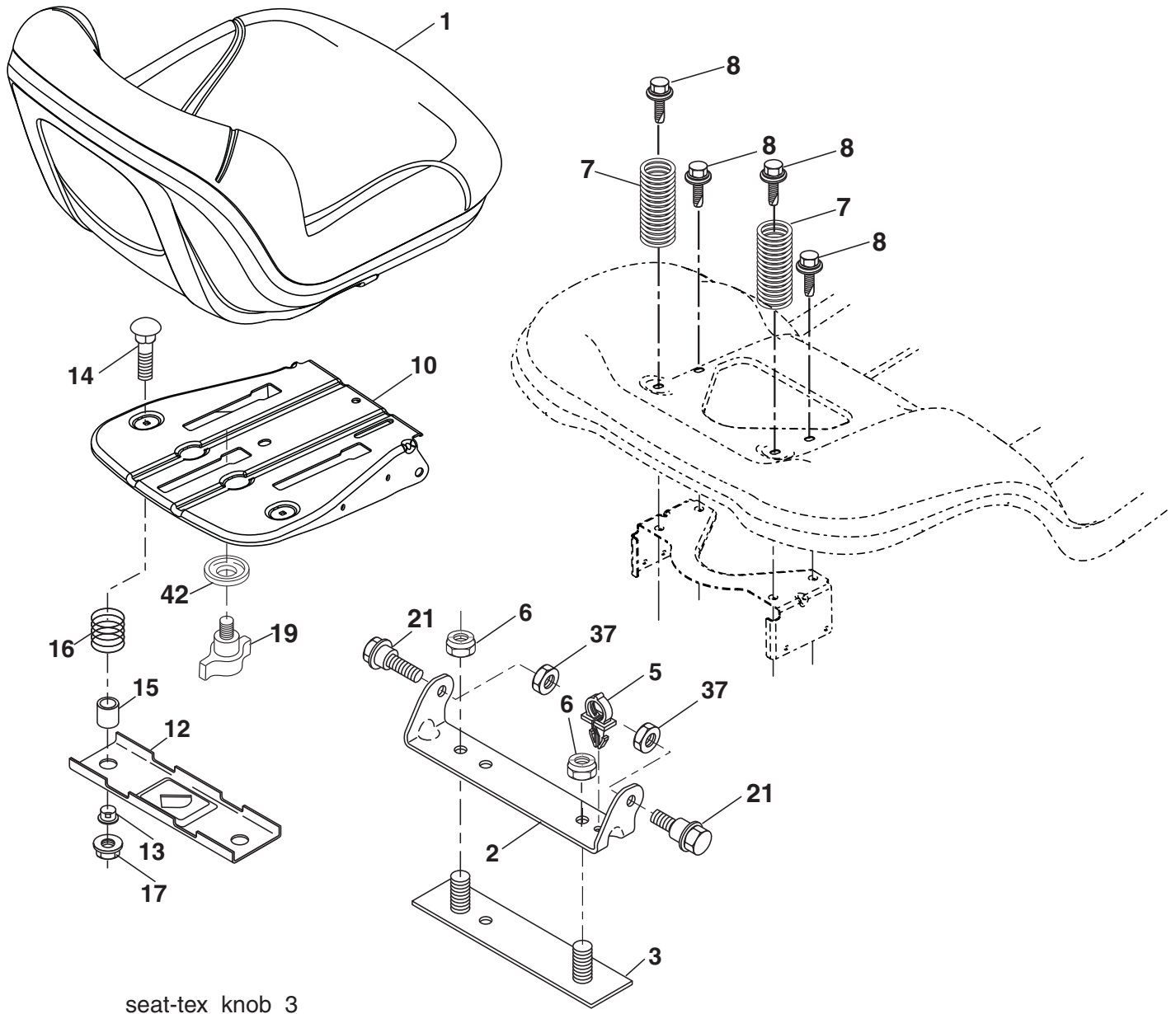

seat-tex_knob_3

KEY NO.	PART NO.	DESCRIPTION
1	532 40 30-17	Seat
2	532 18 01-66	Bracket Pivot Fender
3	532 14 06-75	Strap, Asm Fender
5	532 14 50-06	Clip Push-in Hinged
6	873 80 06-00	Nut, Lock w/Ins. 3/8-16 unc
7	532 12 41-81	Spring, Seat Cprsn
8	532 17 18-77	Bolt 5/16-18 unc x 3/4 w/Sems
10	532 44 18-05	Pan, Seat
12	532 19 93-70	Bracket Mnt.
13	532 12 12-48	Bushing Snap
14	872 05 04-12	Bolt 1/4-20 x 1-1/2

KEY NO.	PART NO.	DESCRIPTION
15	532 13 43-00	Spacer Split
16	532 12 37-40	Spring CPRSN Plate
17	532 12 39-76	Nut Lock 1/4
19	532 19 93-72	Knob Seat
21	532 17 18-52	Bolt, Shoulder 5/16-18
37	873 80 05-00	Nut, Lock 5/16-18 unc
42	532 19 93-71	Cup Washer

NOTE: All component dimensions given in U.S. inches
1 inch = 25.4 mm

**TRACTOR - MODEL NO. PO175A42LT (96048002400), PRODUCT NO. 960 48 00-24
DECALS**

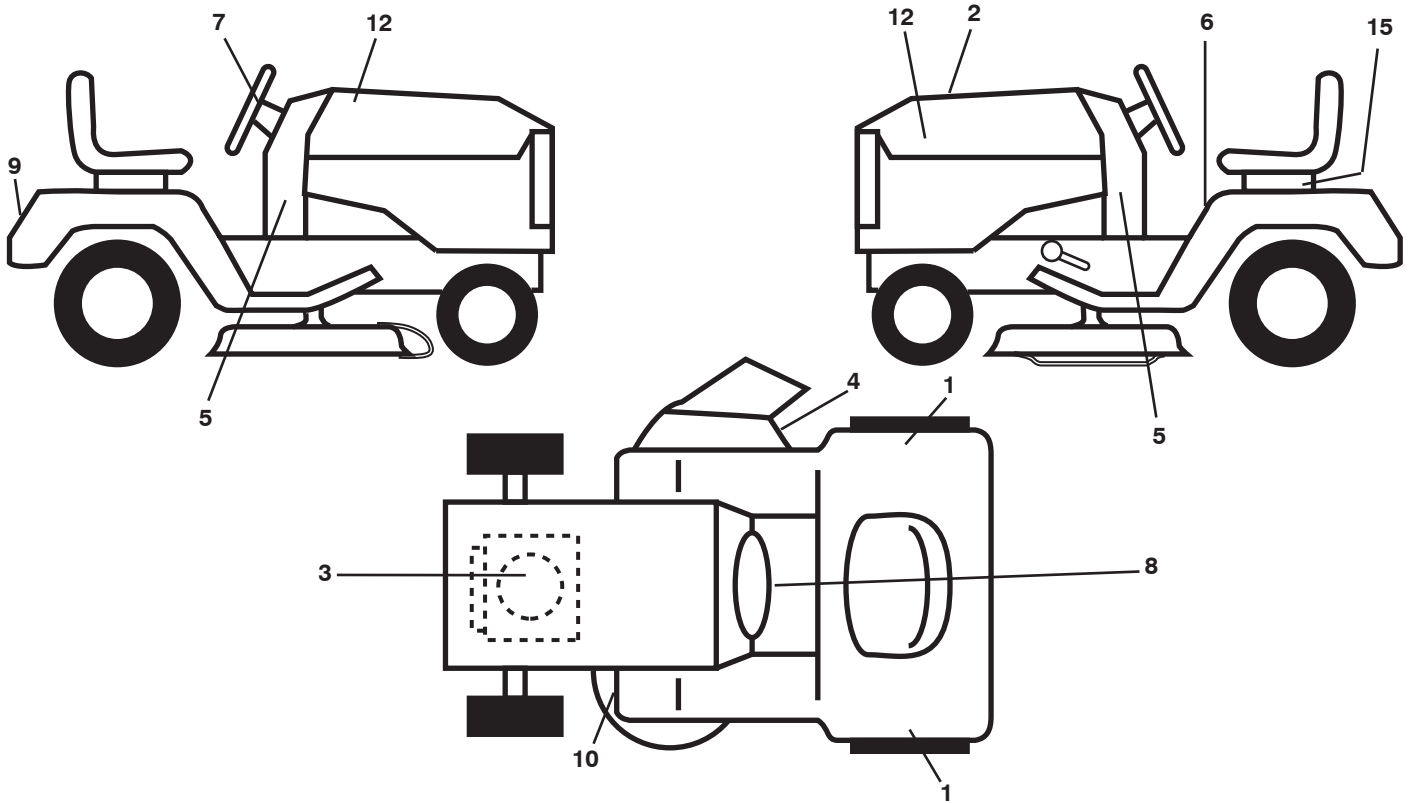

KEY NO.	PART NO.	DESCRIPTION
1	532 44 68-01	Decal, Fender RH/LH Set
	532 44 66-06	Decal, Replacement
3	532 43 10-92	Decal, Engine HP
4	532 17 05-63	Decal, Warning
5	532 43 20-72	Decal, Dash Lower
6	532 41 16-58	Decal, Fender Warning (E&F)
7	532 43 19-82	Decal, Ins Str Wh
8	532 43 52-86	Decal, Warn. Spark
9	532 43 19-86	Decal, Fender

KEY NO.	PART NO.	DESCRIPTION
10	532 16 03-96	Decal, V-Belt Sch.
12	532 43 19-83	Decal, Hood RH/LH
15	532 14 50-05	Decal, Caution, Battery
--	532 16 69-60	Decal, Bypass
--	532 40 95-05	Pad Footrest LH
--	532 41 12-73	Pad Footrest RH
--	532 44 67-45	Manual, Operator's, (English/French)
--	532 44 67-46	Manual, Parts, (English /French)

WHEELS & TIRES

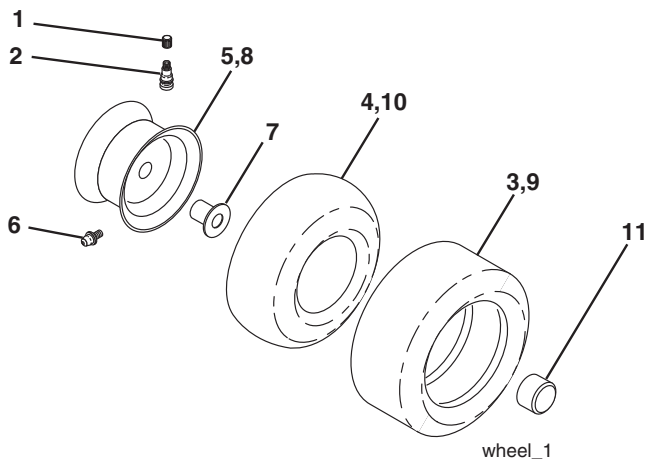

KEY NO.	PART NO.	DESCRIPTION
1	532 05 91-92	Cap, Tire Valve
2	532 06 51-39	Stem, Valve
3	532 10 62-22	Tire, Front
4	532 05 99-04	Tube, Front (Service item only)
5	532 18 33-37	Rim Assembly, 6" Front
6	532 12 49-57	Fitting, Grease (Front wheel only)
7	532 12 49-59	Bearing, Flange (Front wheel only)
8	532 19 33-38	Rim Assembly, 8" Rear
9	532 42 05-31	Tire, Rear
10	532 12 49-26	Tube, Rear (Service item only)
11	532 17 50-39	Cap, Hub Axle
--	532 14 43-34	Sealant, Tire (10 oz. Tube)

SERVICE NOTES

Poulan

PARTS AND SERVICE

This product has been expertly engineered and carefully manufactured to rigid quality standards. As with all mechanical products, some adjustments or part replacement may be necessary during the life of your unit.

For Parts and service, contact our authorized distributor: call 1-800-849-1297

- For replacement parts, have available the following information:
 - a. Model Number/Manufacturer's I.D. Number
 - b. Description of part.

For Technical Assistance: call 1-800-829-5886

For a Parts Manual, go to our website: www.poulan.com

NOTE: HOP provides parts and service through its authorized distributors and dealers; therefore, all requests for parts and service should be directed to your local dealer(s). The philosophy of HOP is to continually improve all of its products. If the operating characteristics or the appearance of your product differs from those described in this Manual, please contact your local dealer for updated information and assistance.

poulan

L'ENTRETIEN ET LES PIÈCES DE RECHANGE

Ce produit, conçu avec les soins les plus attentifs, est fabriqué en accord avec des standards stricts. Comme pour tous les produits avec des parties mobiles, il peut être nécessaire pendant la durabilité de votre machine d'effectuer des ajustements ou le remplacement de certaines pièces .

Pour les pièces de rechange et l'entretien, contactez notre concessionnaire autorisé: appelez 1-800-849-1297

• Pour les pièces de rechange, ayez près de vous:

a. Numéro du modèle/Référence numéro du fabricant

b. Description de la pièce

Pour l'assistance technique: appelez 1-800-829-5886

Pour un manuel de pièces, allez à notre site web: www.poulan.com

N.B.: HOP assure la distribution des pièces de rechange et l'entretien de ses produits par l'intermédiaire des concessionnaires et des distributeurs agréés; par conséquent toute demande de pièces ou d'entretien doit être adressée directement au distributeur agréé le plus proche. La philosophie de HOP est d'améliorer en permanence la gamme complète de ses produits. Si les caractéristiques ou l'apparence de votre outil sont différentes de celles décrites dans ce Manuel, contactez S.V.P. votre concessionnaire pour les informations et l'assistance concernant les mises à jour.

DÉCALCOMANIE

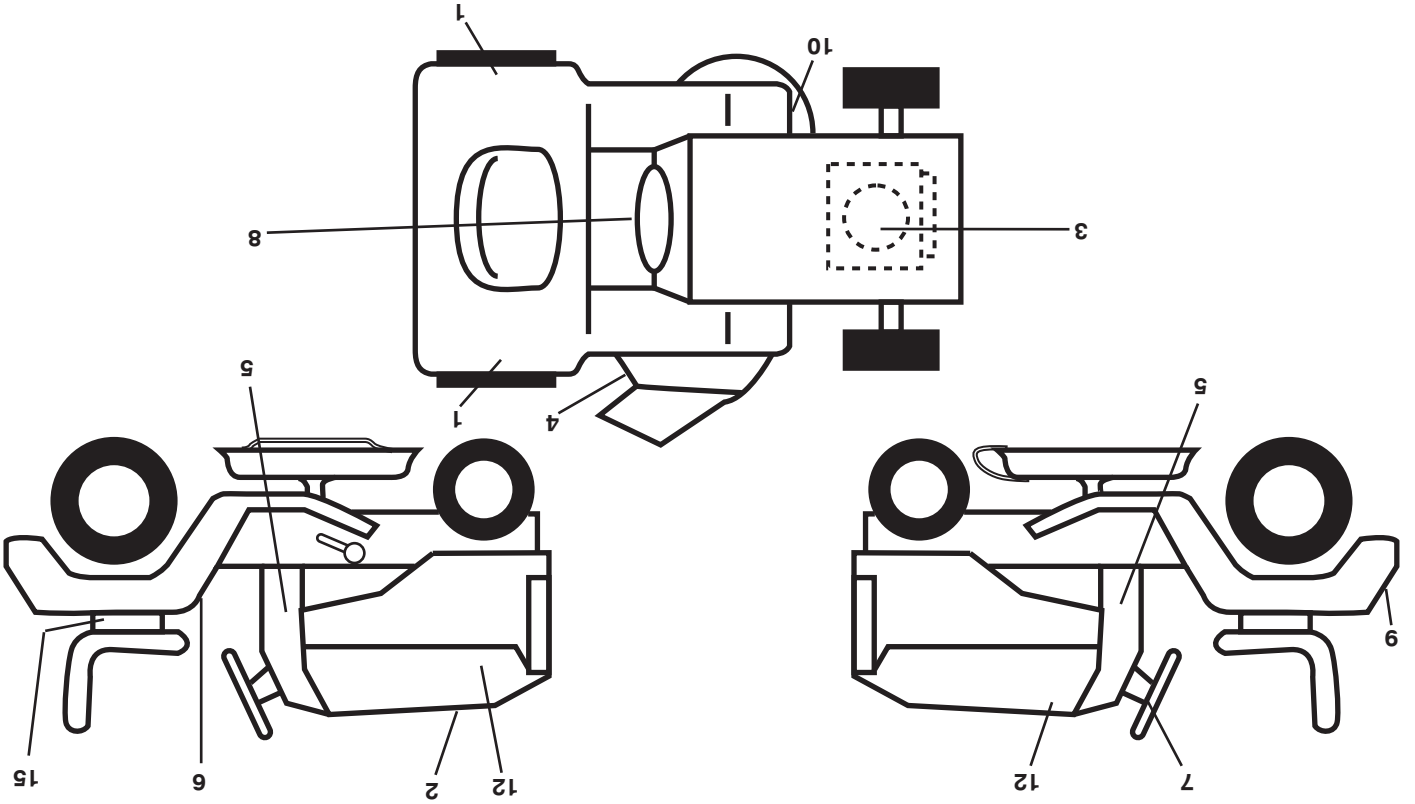

NO. DE DÉ	REF. PIÈCE	DESCRIPTION
10	532 16 03-96	Décalcomanie de la courroie trapézoïdale
12	532 43 19-83	Décalcomanie du capot C.D./C.G.
15	532 14 50-05	Décalcomanie de la batterie
15	532 16 69-60	Décalcomanie
15	532 40 95-05	Coussin Du Repos-Pied CG.
15	532 41 12-73	Coussin Du Repos-Pied CD
15	532 44 67-45	Manuel de L'Opérateur (Anglais/Français)
15	532 44 67-46	Manuel des Pièces de Remplacement (Anglais/Français)

NO. DE DÉ	REF. PIÈCE	DESCRIPTION
1	532 44 68-01	Décalcomanie du aile C.D./C.G.
2	532 44 66-06	Décal, Remplacement
3	532 43 10-92	Décalcomanie du moteur C.V.
4	532 17 05-63	Décalcomanie d'avertissement
5	532 43 20-72	Décalcomanie tableau de bord
6	532 41 16-58	Décalcomanie d'avertissement
7	532 43 19-82	Décalcomanie de volant de direction
8	532 43 52-86	Décalcomanie d'avertissement
9	532 43 19-86	Décalcomanie du aile

ROUES & PNEUS

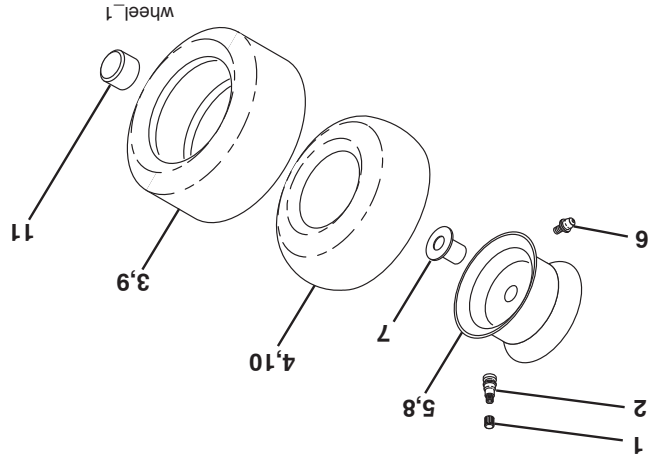

NO. DE DÉ	REF. PIÈCE	DESCRIPTION
1	532 05 91-92	Capuchon de valve
2	532 06 51-39	Tubulure de la valve
3	532 10 62-22	Pneu antérieur
4	532 05 99-04	Chambre à air antérieure
5	532 18 33-37	Pneu F T
6	532 12 49-57	Graisseur (roue antérieure seulement)
7	532 12 49-59	Palier à bride (roue antérieure seulement)
8	532 19 33-38	Ensemble de la jante arrière de 150 x 10
9	532 42 05-31	Pneu arrière
10	532 12 49-26	Chambre à air arrière (non fournie)
11	532 17 50-39	Chapeau de l'essieu
--	532 14 43-34	Joint d'étanchéité de pneu (tube de .30L [10 oz. Tube])

REMARQUE: Toutes les dimensions de composant sont données en pouces E.-U. -- 1 pouce = 25,4 mm.

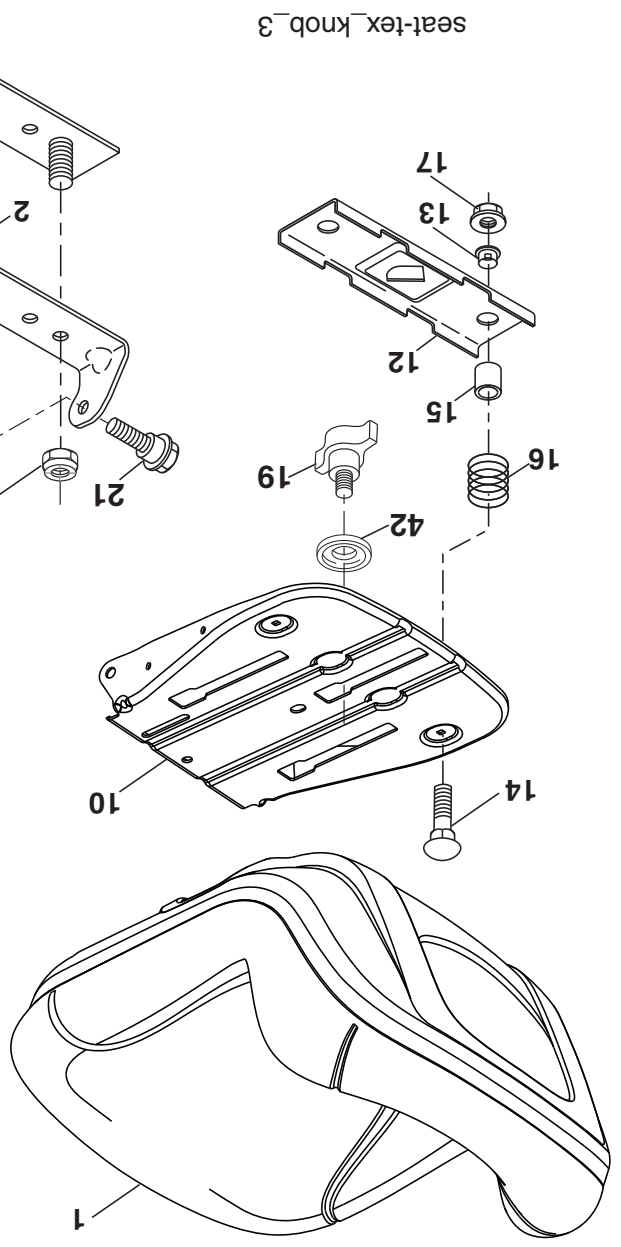

NO. DE PIÈCE	DESCRIPTION
1	Siège
2	Support de pivot
3	Attache De L'ensemble De L'aile
4	Boulon 1/4 - 20 X 1-1/2
5	Collier presse
6	Ecrou 3/8-16 unc
7	Ressort
8	Boulon 5/16-18 unc x 3/4
9	Rondelle
10	Bac Du Siège
11	Ressort
12	Support
13	Douille Fendue De Bouton-Pression
14	Boulon 1/4 - 20 X 1-1/2

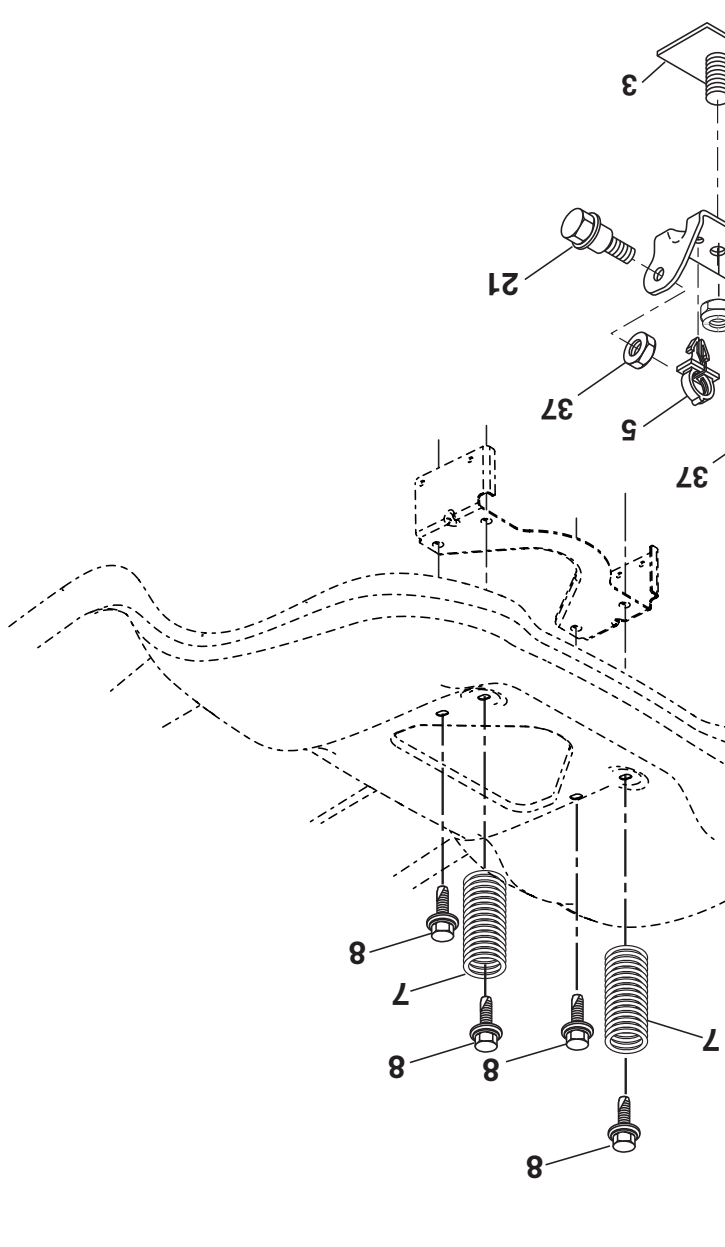

NO. DE PIÈCE	DESCRIPTION
15	Entretoise
16	Ressort 1,310 Ja.
17	Ecrou 1/4 Cat. 5
18	Boulon 5/16-18
19	Bouton Du Siège
20	Ressort 12 39-76
21	Boulon 5/16-18
37	Ecrou 5/16-18 unc
42	Rondelle

REMARQUE: Toutes les dimensions de composant sont données en pouces E.-U. -- 1 pouce = 25,4 mm.

TRACTEUR-NO. DE MODELE PO175A42LT (96048002400), NO. DE PRODUIT 9604800-24

LEVAGE DE TONDEUSE

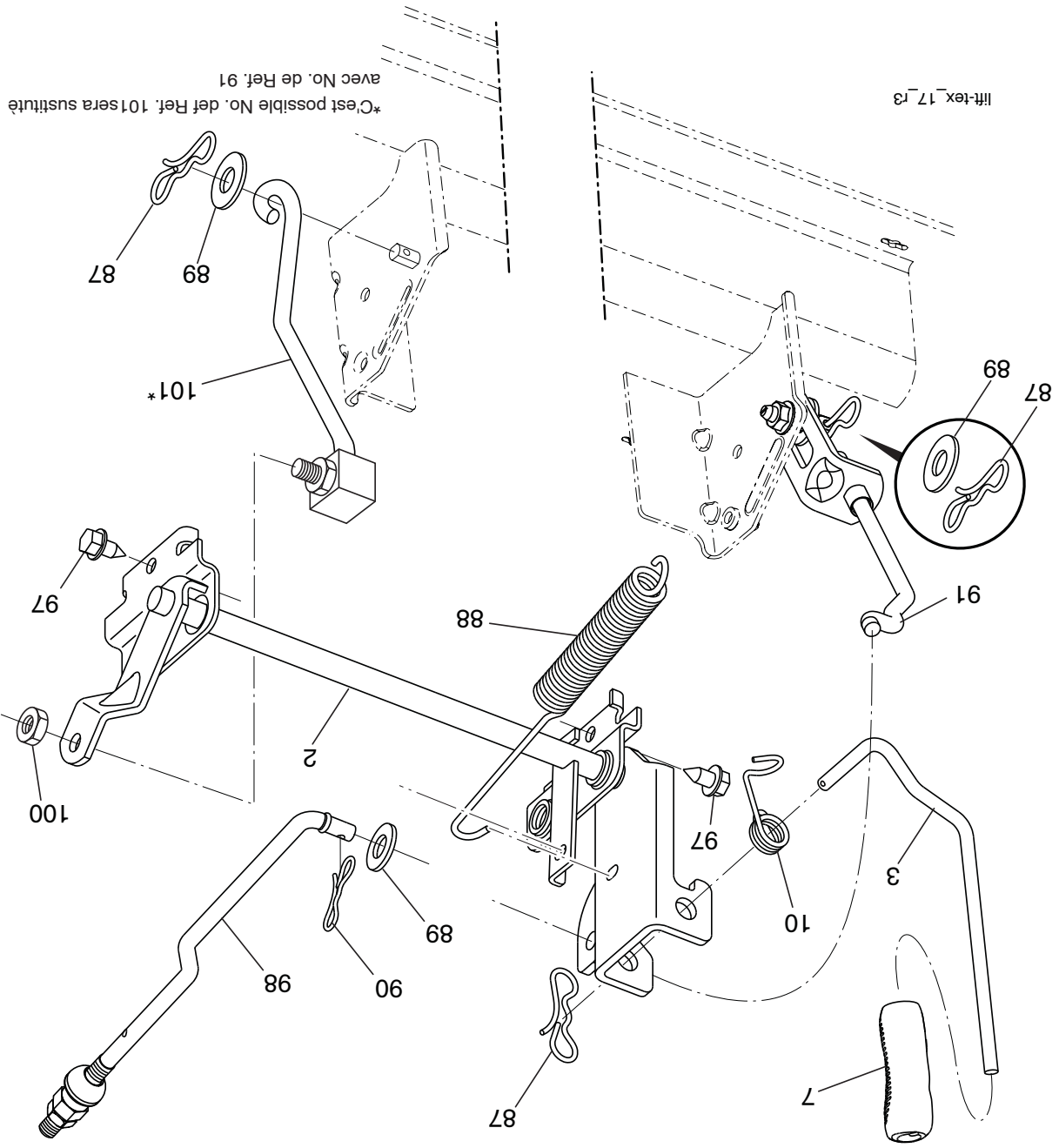

*C'est possible No. de Ref. 101 sera substitué avec No. de Ref. 91

NO. DE PIÈCE	DESCRIPTION
2	Ensemble de l'arbre de levage
3	Levier de l'ensemble, C.D.
7	Axe
10	Ressort De Torsion
10	Ressort De Torsion
87	Goupille Fendue 7/16
88	Ressort
88	Ressort
89	Rondelle
90	Goupille Fendue 5/16

NO. DE PIÈCE	DESCRIPTION
91	Levier De Levage
97	Vis 3/8-16 x .75
98	Levier De Levage
98	Levier De Levage
100	Ecrou 3/8 -16 unc
101	Ensemble du Levier De Levage

REMARQUE: Toutes les dimensions de composant sont données en pouces E.-U. -- 1 pouce = 25,4 mm.

NO. DE PIECE	DESCRIPTION	NO. DE PIECE	DESCRIPTION
1	532 19 99-11 Carter De Tondeuse	56	532 19 90-92 Entretien
6	532 19 51-86 Bras De Suspension	57	817 00 06-16 Vis 3/8-16 x 1
7	532 41 63-58 Vis #10 x 0.750	59	532 14 10-43 Protecteur TUV du galet-tendeur
8	532 19 30-03 Boulon/Rondelle 7/16 - 20 unft	60	532 19 72-61 Bras du frein
11	532 13 89-71 Lame	62	872 11 06-16 Boulon 3/8-16 unc x 2
13	532 19 28-72 Abre/Mandrin	63	532 19 94-77 Bras de tondeuse
14	532 18 72-81 Boitier/Mandrin	64	532 19 97-90 Combinaison du frein
15	532 11 04-85 Roulement à billes/Mandrin	67	532 40 30-12 Poignée
19	532 19 65-39 Boulon	68	532 42 96-36 Courroie trapézoïdale
20	532 15 97-70 Chicane	69	872 14 05-05 Boulon 5/16-18 x 5/8
21	873 68 05-00 Ecroû 5/16-18 unc	70	532 19 83-32 Ensemble de l'embrayage
23	532 19 25-57 Support	113	817 00 05-10 Vis 5/16-18
24	532 10 53-04 Chapeau	122	532 19 72-58 Guide courroie du moteur CG
25	532 19 70-26 Ressort de torsion	123	532 19 72-59 Guide courroie du moteur CD
26	532 11 04-52 Ecroû	144	532 19 92-04 Guide courroie
27	532 40 30-04 Défecteur de la glissière	145	532 19 31-97 Poulie
29	532 13 14-91 Tige	147	532 40 19-71 Ressort
30	532 17 39-84 Vis	152	532 43 51-11 Ensemble du Embrayage
31	532 18 76-90 Rondelle	188	532 19 51-61 Goujon
32	532 19 74-73 Poulie/Mandrin	189	873 90 05-00 Ecroû
33	532 40 02-34 Ecroû	192	532 19 72-60 Support CG
34	872 11 06-12 Boulon 3/8-16 x 1-1/2 Cat. 5	195	817 00 06-12 Vis 3/8-16 x 3/4
36	532 19 73-79 Poulie	208	817 67 06-08 Vis 3/8-16 x 1/2
37	819 13 13-16 Rondelle 13/32 x 13/16 x 16 Ja.	- -	532 19 28-70 Ensemble du mandrin (Inclut boitier, ensemble arbe, et palier seulement
38	532 43 25-20 Guide courroie du mandril	- -	873 90 06-00 Ecroû 3/8-16 unc
40	873 90 06-00 Ecroû 3/8-16 unc	- -	532 19 84-10 Ressort de torsion
42	532 19 84-10 Ressort de torsion	- -	532 41 52-41 REMPLACER TONDEUSE
43	532 19 72-56 Ressort de torsion	- -	532 41 52-41 REMPLACER TONDEUSE
46	532 13 77-29 Vis 1/4-20 x 5/8	- -	532 41 52-41 REMPLACER TONDEUSE
47	532 19 72-50 Support	- -	532 41 52-41 REMPLACER TONDEUSE
55	532 43 71-10 Bras du galet-tendeur	- -	532 41 52-41 REMPLACER TONDEUSE

REMARQUE: Toutes les dimensions de composant sont données en pouces E.-U. -- 1 pouce = 25,4 mm.

NO. DE PIECE	DESCRIPTION
1	Volant de direction 532 42 45-43
2	Ensemble d'essieu antérieur 532 41 81-68
4	Ensemble de broche C.G. 532 40 30-87
5	Ensemble de broche C.D. 532 40 30-88
6	Rondelle 0,75 x 1,23 532 12 49-31
7	Rondelle 25/32 x 1-5/8 x 16 Ja. 532 12 17-48
8	Pince #T5304-75 812 00 00-29
9	Capuchon De Broche 532 12 12-32
13	Rondelle 25/32 x 1-1/4 x 16 Ja. 532 12 17-49
14	Rondelle 3/8 810 04 06-00
15	Ecrox 3/8-24 un† 873 54 06-00
16	Arbre De Direction 532 42 93-74
19	Plaque De Direction 532 19 47-29
20	Bote De Direction 532 41 12-91
21	Adaptateur du volant de direction 532 18 67-37
22	Support 532 42 05-37
26	Insert de chapeau du volant de direction 532 42 46-91
28	Vis 3/8-16 x 3/4 817 00 06-12
33	Rondelle 5/16 810 04 05-00
35	Secteur Denté 532 19 47-32
45	Rondelle 11/32 x 2-3/8 x 12 Ja. 819 11 38-12
53	Rondelle .793 x 1.637 x .060 532 18 89-67
57	Support 532 40 74-65
58	Boulon 532 19 47-47
59	Rondelle 532 19 47-48
60	Ecrox 5/8-11 873 97 10-00
61	Barre De Direction C.G. 532 19 47-40
62	Barre De Direction C.D. 532 19 47-41
63	Vis 5/16-18 x 3/4 817 00 05-12
64	Pince D' Arrêtair 532 19 98-49
66	Boulon 7/16-14 x 3 871 02 07-48
67	Coussinet 532 19 47-37
68	Ecrox 7/16-14 Cat. 5 873 90 07-00
69	Rondelle 1.5 x .505 x .118 532 19 91-62
70	Support 532 19 61-97
71	Arbre De Rallonge De Direction 532 19 07-52
72	Boulon 5/16-18 x 4 532 42 89-82
74	Pallier 532 12 49-37
120	Support 532 41 56-89
121	Vis 5/16-18 x 1/2 817 49 05-08

REMARQUE: Toutes les dimensions de composant sont données en pouces E.-U. -- 1 pouce = 25,4 mm.

TRACTEUR-NO. DE MODELE PO175A42LT (96048002400), NO. DE PRODUIT 9604800-24

ENSEMBLE DE LA DIRECTION

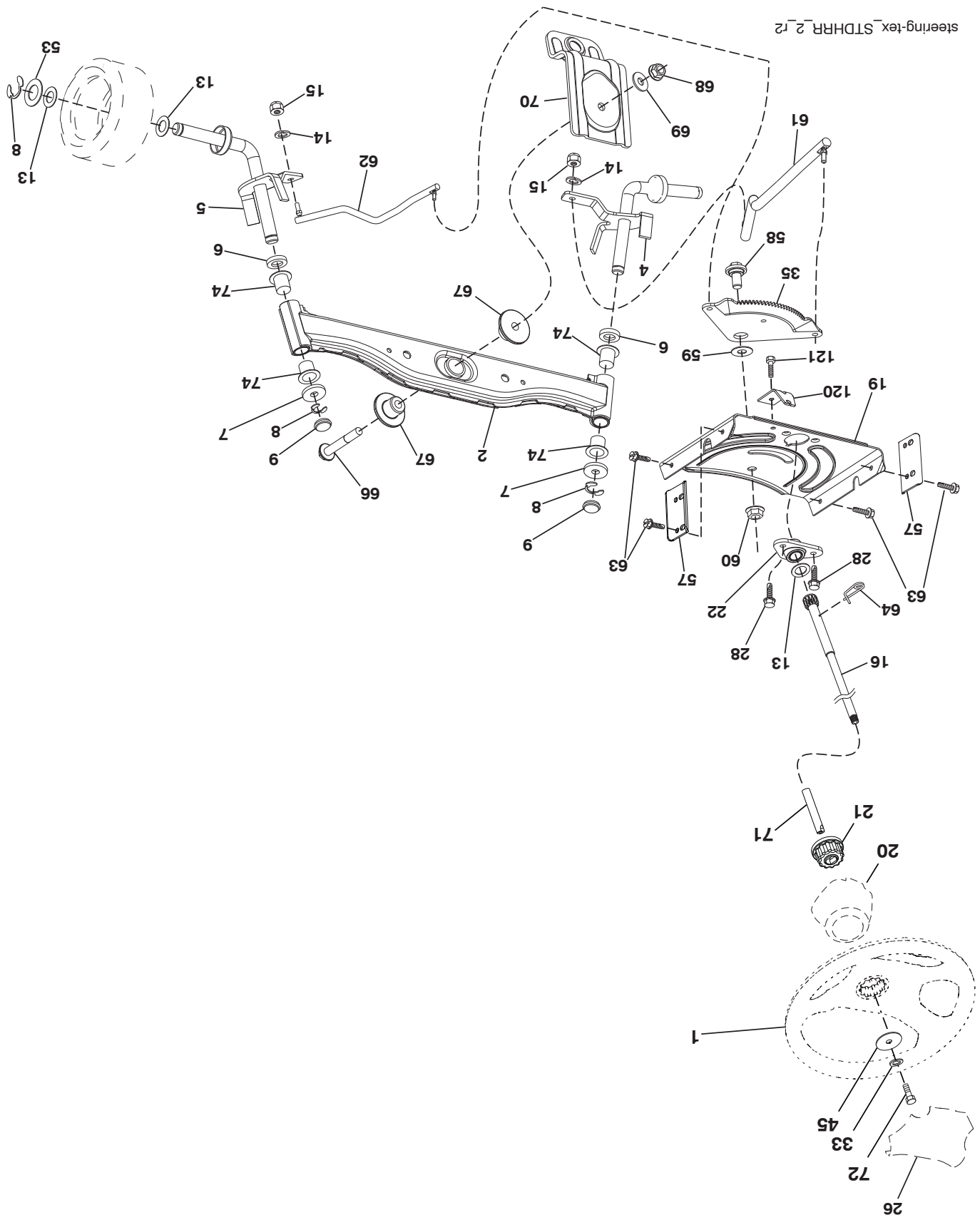

NO. DE REF. PIÈCE	DESCRIPTION
1	Moteur Briggs No. de Modèles 1C707-3487-G1 (438654) (Commandez les pièces du fabricant du moteur)
2	Silencieux
9	Guide Courroie Du Moteur
12	Pouille
15	Réservoir d'essence 1.5
18	Bouchon de réservoir d'essence
20	Commande Des Gaz/Starter
21	Vis #10 x 0.750
28	Conduite d'essence
29	Pare-Étincelles
37	Bride de serrage du tuyau
42	Rondelle 7/16
45	Écrou 1/4-20 unc
69	Garniture
79	Vis 5/16 - 18 x .75
84	Vis 3/8-16 x 1-1/4
85	Boulon 7/16-20 x 4 Cat. 5-1.5
90	Vis 3/8-16 x 1
96	Rondelle 9/32 x 7/8 x 16 Ja.
97	Vis 1/4-20 x 3/4
122	Bec de vidange d'huile

REMARQUE: Toutes les dimensions de composant sont données en pouces E.-U. — 1 pouce = 25,4 mm.

Pour des pièces de service et de rechange de moteur, réclamez le numéro de téléphone libre pour votre fabricant de moteur énuméré ci-dessous:

Briggs & Stratton 1-800-233-3723

Informations concernant la puissance théorique du moteur

La puissance brute pour chaque Modèle de moteur à essence est indiquée conformément au code J1940 (procédure de calcul de la puissance et du couple des petits moteurs) de la SAE (Society of Automotive Engineers) et les performances théoriques ont été obtenues et corrigées selon SAE J1995 (révision 2002-05). Les valeurs de couple sont calculées sur la base de 3060tr/min et celles de puissance sur la base de 3600tr/min. La puissance brute réelle du moteur peut être plus faible notamment à cause des conditions de fonctionnement et des variations d'un moteur à l'autre. Compte tenu de la grande variété de machines sur lesquelles nos moteurs sont utilisés et du nombre de problèmes environnementaux applicables au fonctionnement des équipements, il se peut que le moteur à essence ne développe pas sa puissance théorique une fois qu'il est monté sur une machine particulière (puissance nette ou réelle «sur site»). Cette différence s'explique par un grand nombre de facteurs, tels que (liste non limitative): accessoires d'utilisation (température, admission, refroidissement, carburateur, pompe à essence, etc.), limites d'utilisation, conditions ambiantes d'utilisation (température, humidité, altitude) et variations d'un moteur à l'autre. Pour des raisons de fabrication et de capacité limitées, Briggs & Stratton est susceptible de remplacer ce Modèle par un moteur plus puissant.

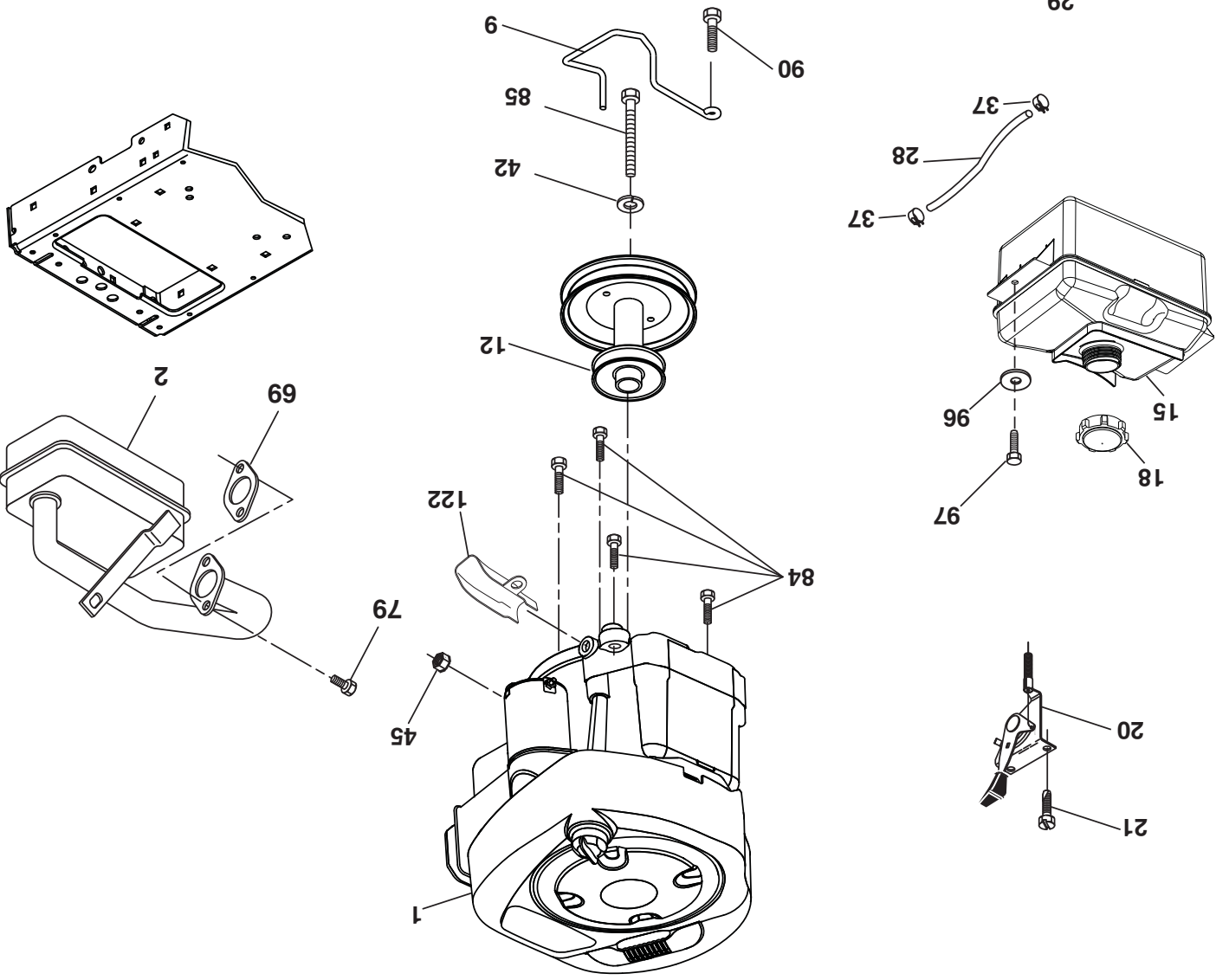

engine-tex_BS_36

EQUIPMENT FACULTATIF
PARA-ÉTINCELLES

NO.	DÉ	REF.	DESCRIPTION
NO	DE	PIECE	
1	---	---	Transmission, Gentrans (415663) (Commandez Les Pièces Du Fabricant Du Transmission.)

2	532	12 35-83	Ciè
22	532	42 10-63	Tige Du Changement De Vitesse
23	532	10 69-33	Bouton
33	812	00 00-01	Anneau "E"
35	532	19 77-22	Tige Frein De Stationnement
37	532	12 17-49	Rondelle 25/32 X 1-1/4 X 16 Ja.
42	532	12 48-72	Couverture De La Pédale
49	872	11 06-14	Boulon
50	532	19 43-27	Poulie
51	873	90 06-00	Ecron 3/8-16
52	532	19 43-26	Galet-Tendeur
56	532	19 72-53	Courroie D'entraînement
64	532	19 62-00	Ensemble De L'arbre
70	532	44 03-23	Console
73	874	49 05-44	Boulon 5/16-18 Cat. 5
74	532	14 24-32	Vis 1/4 X 1/2
99	532	42 73-40	Tige
116	873	90 05-00	Ecron 5/16-18
125	817	00 05-12	Vis 5/16-18 X 3/4
131	876	02 03-12	Goupille fendue 3/32/ x 3/4
143	817	49 05-08	Vis 5/16-18 x 1/2 Tytt
160	532	16 94-84	Pince D'Arrêt, Collier De Retenue
161	532	10 57-09	Ressort De Rappel D'embrayage
165	532	19 62-12	Coussinet
166	532	42 91-64	Ecron .625
167	532	40 52-57	Loquet
172	532	41 56-64	Attache De Torsion
174	532	19 72-89	Ecron
175	532	41 56-77	Bras D'embrayage
176	532	19 62-14	Bras du Tige D'embrayage
178	532	19 74-56	Ressort D'embrayage
184	532	44 15-04	Guidon frien
185	872	11 06-22	Boulon
186	532	19 43-21	Entretoise
187	819	13 32-10	Rondelle
188	532	19 43-23	Raccord
189	532	19 43-17	Levier Coude
190	532	19 43-18	Guidon Levier Coude
203	819	11 11-16	Rondelle 11/32 X 11/16 X 16 Ja.
205	532	12 17-48	Rondelle 25/32 X 1-5/8 X 16 Ja.
221	532	40 31-87	Pince
232	874	78 07-16	Boulon 7/16-14 X 1 Cat. 5
233	532	40 52-96	Rondelle
295	532	42 03-06	Axe de chape
296	532	42 04-71	Vis 5/16-18 x 3
297	532	42 02-23	Ecron 1/4
298	532	41 56-94	Axe de chape
299	532	41 56-83	Support
300	532	41 56-81	Guide-courroie
301	532	41 56-80	Poulie
302	532	41 56-66	Poulie
303	872	11 06-18	Boulon 3/8-16 x 2-1/4
305	532	41 56-92	Câble

REMARQUE: Toutes les dimensions de composant sont données en pouces E.-U. -- 1 pouce = 25,4 mm.

TRACTEUR-NO. DE MODELE PO175A42LT (96048002400), NO. DE PRODUIT 9604800-24

ENTRAINMENT

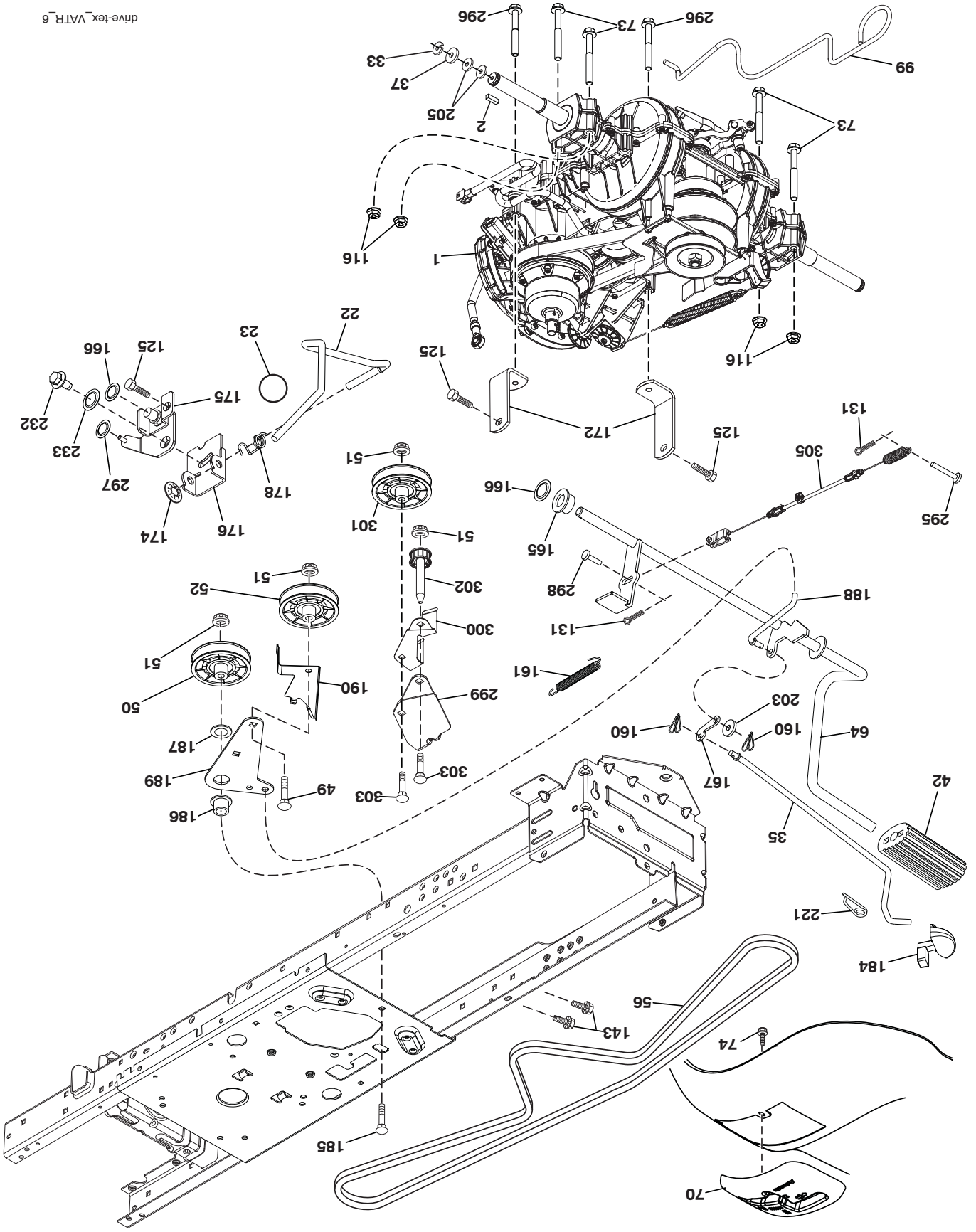

drive-lex_VATR_6

NO. NO.
 DE DE
 REF. REF.
 PIECE DESCRIPTION

5	532 41 17-64	Pare-Chocs
14	532 40 61-79	Capot
18	532 42 67-41	Calandre
29	532 18 75-69	Insert
34	532 19 61-25	Plaque Du Motor
36	817 06 05-12	Vis 5/16-18 X 3/4
37	532 42 09-86	Aile
52	873 68 05-00	Ecrou 5/16-18
58	532 41 22-80	Barre D'attelage
68	817 49 05-08	Vis 5/16-18 X 1/2
130	532 41 63-58	Vis #10 X 0.750
137	532 18 49-21	Pare-Chocs
138	532 40 97-30	Godet
150	532 18 44-61	Canalisation d'admission d'air
151	532 18 75-68	Support
152	532 19 95-35	Deflecteur
159	817 00 06-12	Vis 3/8-16 X 3/4
162	532 14 24-32	Vis 1/4 X 1/2
175	532 19 32-43	Traverse Moyenne
176	532 40 07-76	Vis 10-24 X 5/8
177	532 19 52-28	Coussinet
180	532 41 50-63	Chassis
181	532 40 30-25	Coussinet
182	532 19 30-57	Tableau De Bord
183	874 52 05-20	Boulon 5/16-18 X 1-1/4
189	817 00 05-12	Vis 5/16-18 X 3/4
194	873 90 05-00	Ecrou 5/16-18
196	532 41 45-79	Ensamble levier de levage
212	532 19 54-02	Lentille
213	874 76 05-12	Boulon 5/16-18 X 3/4
217	532 40 91-67	Tige
218	532 19 63-95	X Pare-Chocs Arrêt
228	532 19 51-61	Attache A Tenon
235	532 40 61-29	Entretoise De L'aile
236	873 93 05-00	Ecrou 5/16-18
287	817 60 04-06	Vis 1/4-20 X 3/8

REMARQUE: Toutes les dimensions de composant sont donnees en pouces E.-U. -- 1 pouce = 25,4 mm.

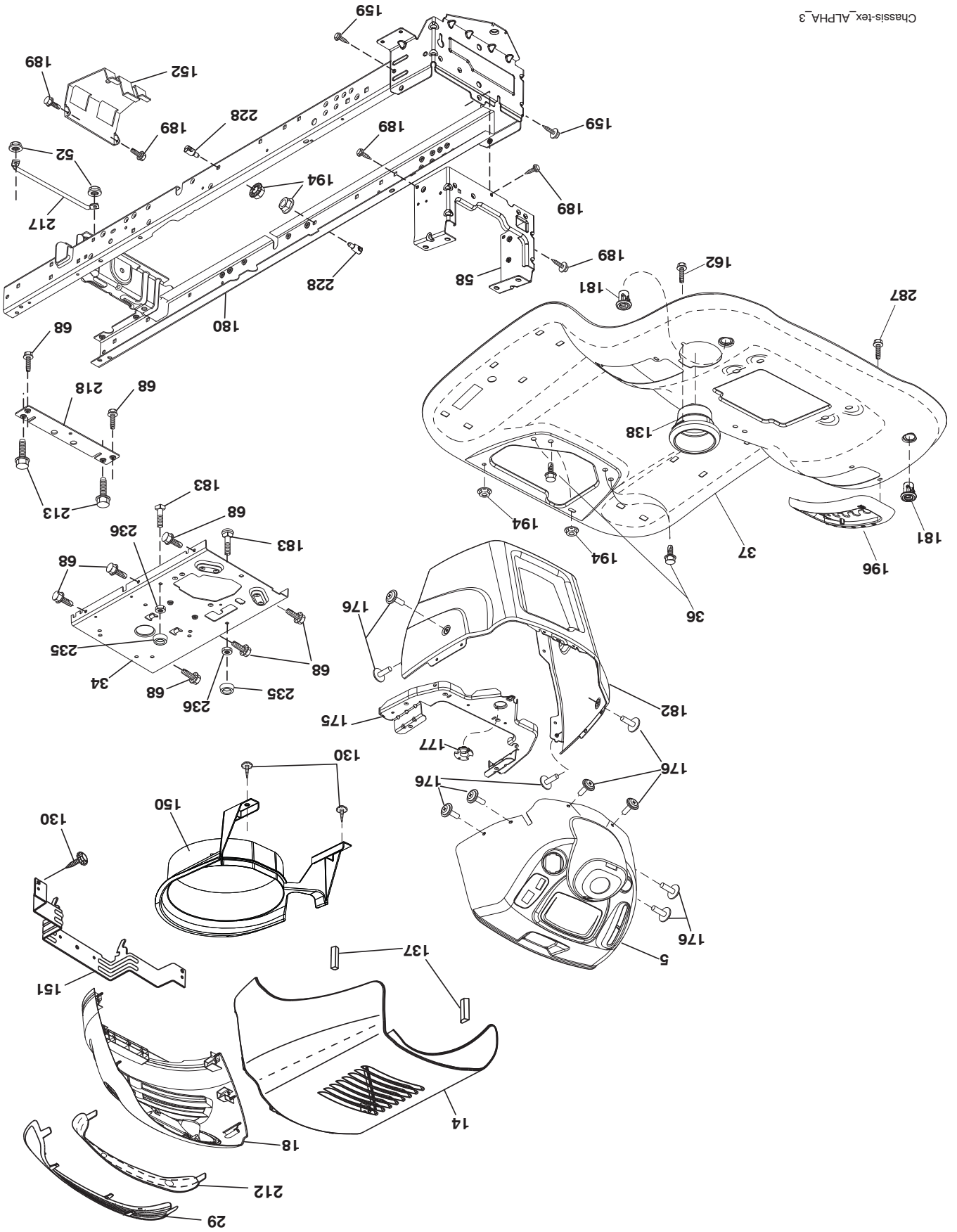

NO. DE PIECE	DESCRIPTION	REF.
1	Batterie	532 16 34-65
2	Boulon 1/4-20 Unc X 3/4	874 76 04-12
8	Bac De Batterie	532 19 32-28
16	L'Interrupteur De Verrouillage	532 17 61-38
21	Harnais d'allongement des phares	532 17 56-88
22	Poire	532 00 41-52
25	Câble 6 Ja.	532 41 28-94
26	Fusible	532 17 51-58
27	Ecroû 1/4-20 Unc	873 51 04-00
28	Câble 18" 6 Ja.	532 19 88-85
29	Interrupteur Du Siège	532 19 27-49
30	Interrupteur Ign	532 19 33-50
33	Cle/Châin	532 41 19-35
34	Interrupteur de lumière	532 11 07-12
40	Harnais	532 40 10-98
41	Vis 1/4-20 Unc X 1/2	817 72 04-08
42	Couverture	532 13 15-63
43	Solénoïde	532 19 25-07
55	Vis 5/16-18 X 3/4	817 06 05-12
71	Harnais	532 44 15-44
79	Montre/ Poire	532 17 52-42
87	Interrupteur	532 19 78-02
90	Couverture	532 43 53-95
102	Harnais	532 41 97-81
105	Interrupteur	532 40 75-68

REMARQUE: Toutes les dimensions de composant sont données en pouces E.-U. -- 1 pouce = 25,4 mm.

COMMENT UTILISER CE MANUEL

Ce manuel a été dessiné pour fournir le client avec les moyens d'identification des pièces de détails du tracteur quand il/elle a besoin de commander les pièces de rechange. Les illustrations ne peuvent pas représenter exactement le modèle que vous avez acheté. N'utilisez pas ce manuel comme un guide dans le montage et/ou démontage de votre tracteur. La visserie montrée est plus grande pour faciliter l'identification.

Chaque tracteur a un numéro de modèle particulier.

Le numéro de modèle du produit se trouvera sur l'aile, dessous le siège.

Lorsque vous commandez des pièces de rechange, donnez toujours les renseignements suivants:

- Produit - "Tracteur"
- Numéro du Modèle - "P0175A42LT (96048002400)"
- Numéro de la Pièce
- Description de la Pièce

TABLE DE MATIERES

SCHEMA.....	3
ELECTRIQUE.....	4-5
CHASSIS/ENCEINTES.....	6-7
ENTRAÎNEMENT.....	8-9
MOTEUR.....	10-11
ENSEMBLE DE LA DIRECTION.....	12-13
CARTER DE TONDEUSE.....	14-15
LEVIER DE LEVAGE DE LA TONDEUSE.....	16
ENSEMBLE DU SIÈGE.....	17
DECALCOMANIES.....	18
L'ENTRETIEN ET LES PIÈCES DE RECHANGE.....	20

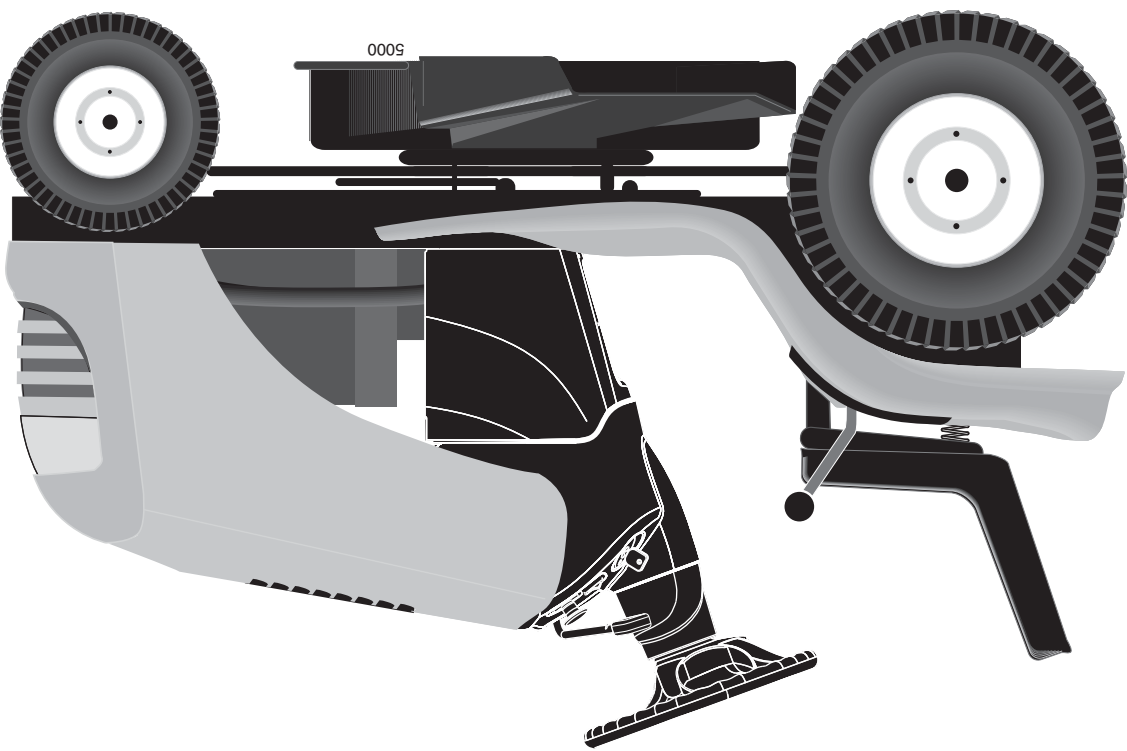

MANUEL DE PARTIES DE RÉPARATION

MODÈLE:

P0175A42LT
TRACTEUR DE PELOUSE

PORTEZ TOUJOURS DES LUNETTES DE SÉCURITÉ LORS DE L'UTILISATION.

Visitez notre site web : www.poulan.com

532 44 67-46

09.28.11 BD
Imprimé en los E.E.U.U.

AVERTISSEMENT:  Lisez soigneusement le Manuel suivez tous les Avertissements et les Instructions de Sécurité. Les blessures sérieuses peuvent en résulter si vous ne lisez pas ces Avertissements et Instructions de Sécurité.