

WHEEL ADJUSTERS

IDLER WHEEL
ADJUSTER

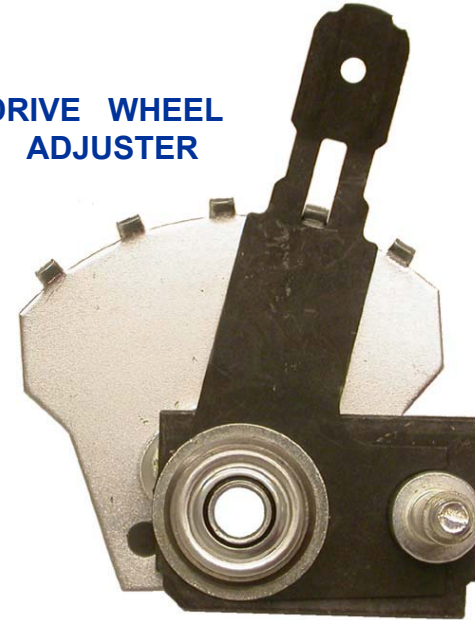

DRIVE WHEEL
ADJUSTER



Wheel adjusters are used to adjust the wheel position so that grass is cut at different heights, usually between 1 ½ and 4 inches.

- The simplest and lowest cost wheel adjusters are shoulder bolts that attach directly to the housing.
 - To change the mowing height, the customer must use wrenches to move shoulder bolts to different holes in the housing.
 - Few customers buy mowers with wheels bolted to the housing.
- There are wheel adjusters for idler wheels.
- The wheel adjusters used with drive wheels have a bearing.

WHEEL ADJUSTERS



When you have the gear teeth worn on a drive wheel, what problems do you look for?

WHEEL ADJUSTERS

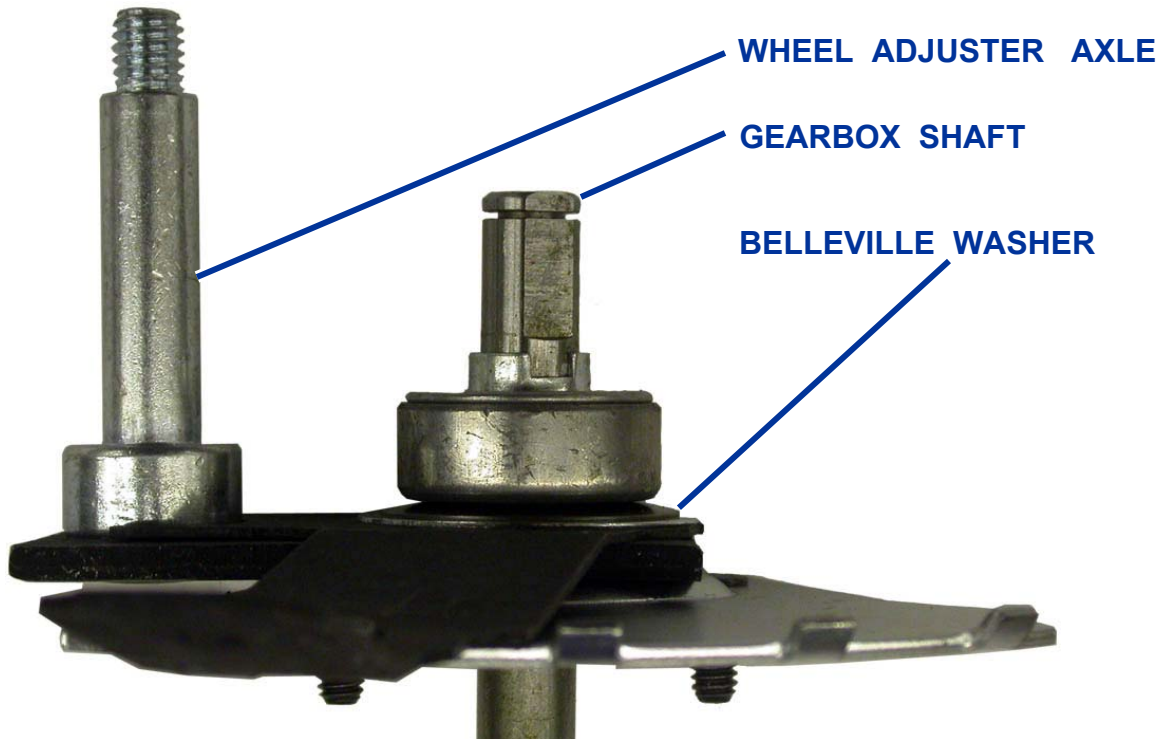

Items to check:

- If there is trash inside, inspect and if needed change the dust cover.
- Remove the pinion and inspect the alignment of the gearbox shaft and the wheel adjuster axle. They should be parallel.
 - If the shafts are not parallel, there will be wear to the plastic gear teeth on drive wheel.
 - The axle arm can be straightened, If the Belleville washer is keeps tension on the adjuster assembly,
 - If the axle is not hardened, you will have to polish off any distortion.

WHEEL ADJUSTERS

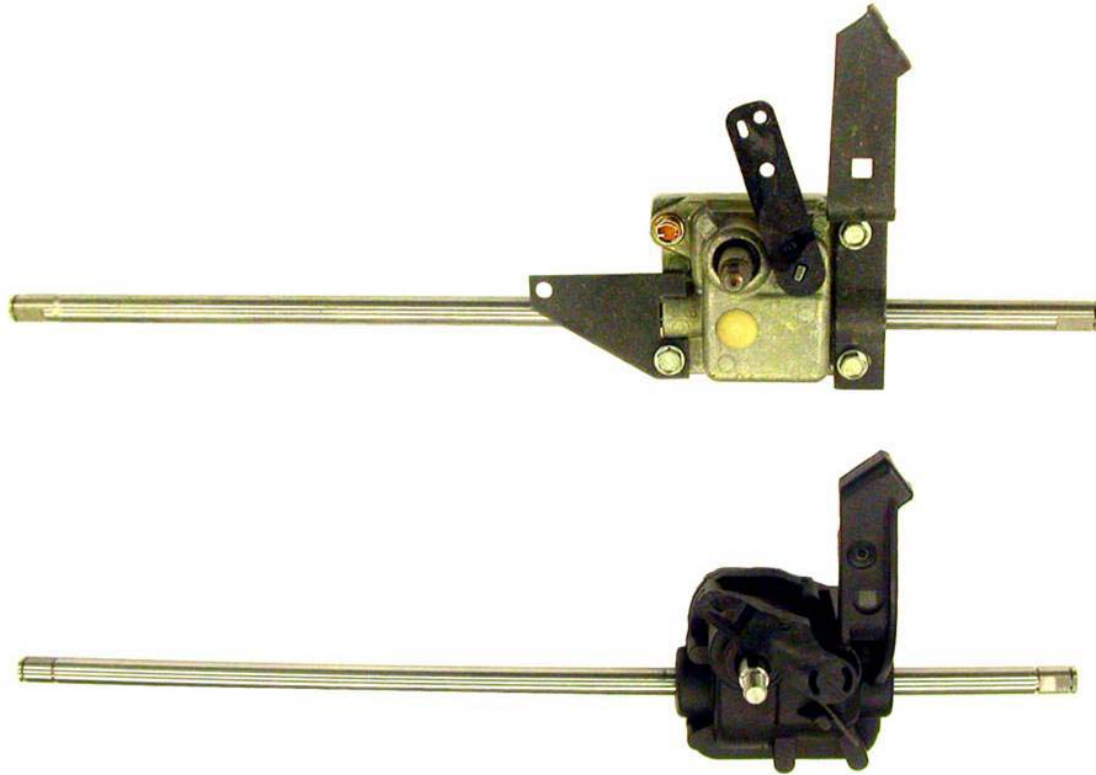

SYMPTOMS:

1. The drive system works intermittently, possibly only a few seconds at a time.
or
2. The gearbox appears to be locked up.

Before changing a gearbox, check the ball bearings in the wheel adjusters.
(needs to be checked while dis-assembled)

WHEEL ADJUSTERS

If the ball bearings in the wheel adjuster have failed or are near failure:

- If the ball bearings lock up or seize, the drive system will also be locked up.
- If the ball bearings are grabbing, the drive system will work intermittently.
- From outward appearances the problem will be the gearbox or transmission.

As this must be inspected while disassembled, the installer should check the bearings.

Inspect ball bearings for:

- Wear and holes in the seal
- Allows noticeable gearbox shaft movement

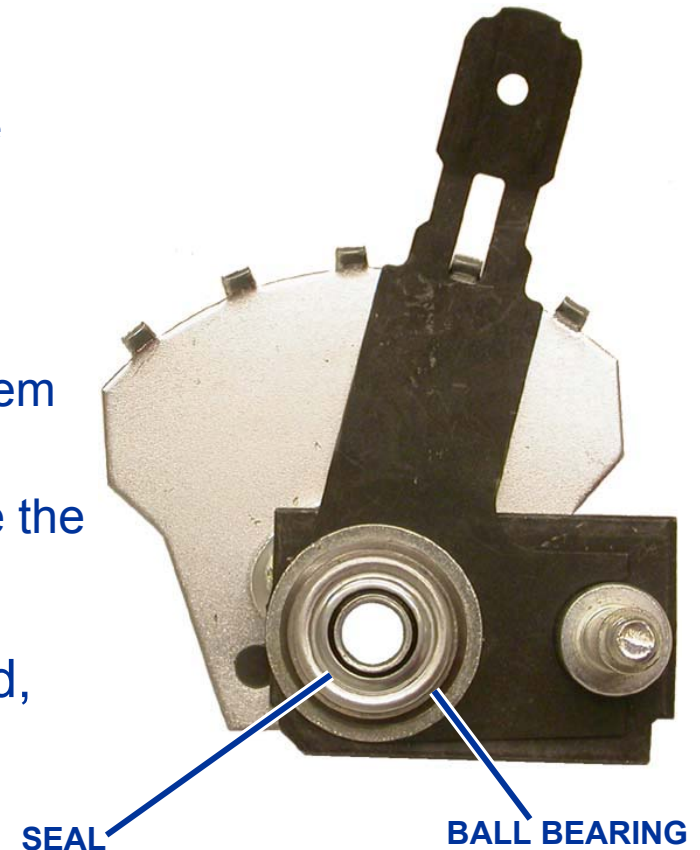

WHEEL ADJUSTERS

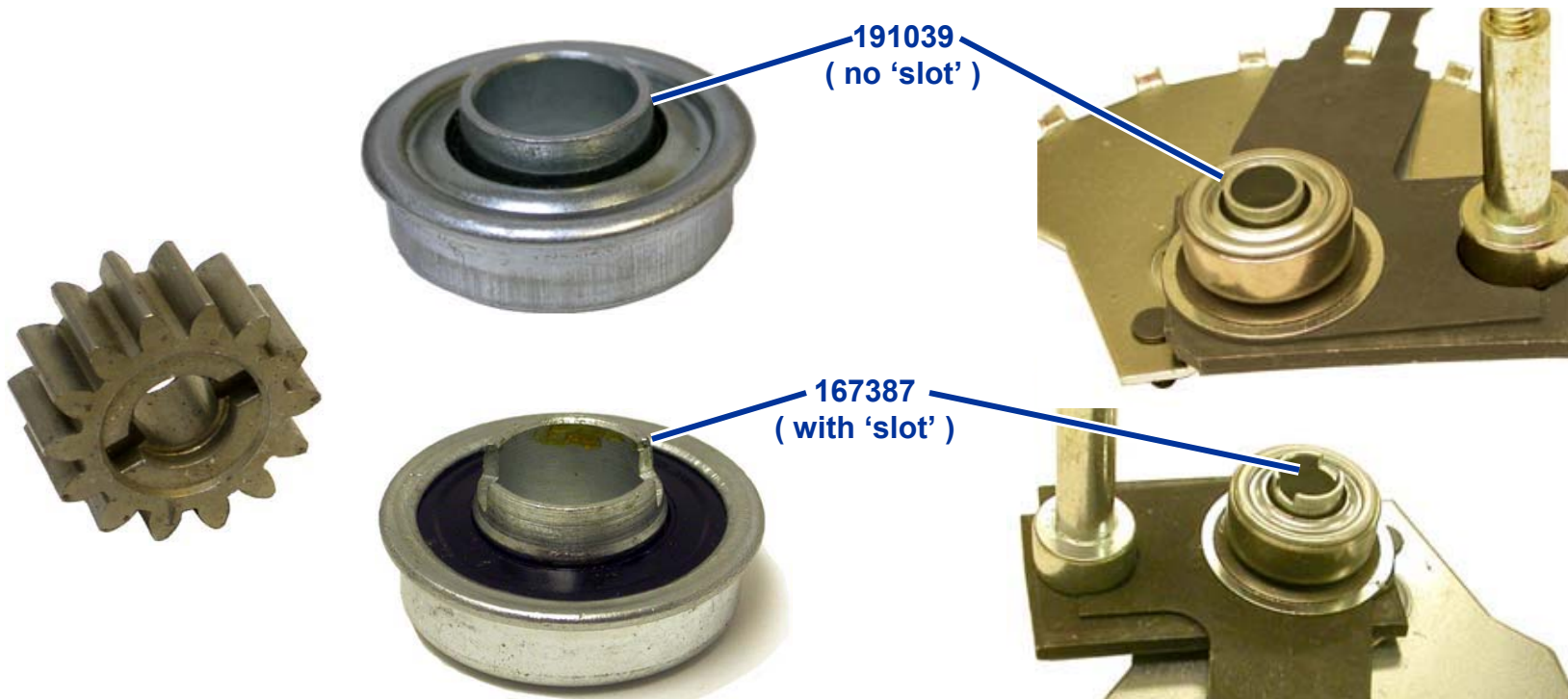

The ball bearing can be replaced:

- On product made before 2005, 167387 ball bearing with 'slot' can be used for front drive self propelled wheel adjuster repair.
- On product 2005 and newer, a 191039 bearing will be used in the wheel adjuster. (no slot)
- The bearing in the wheel adjuster must match the pinion assembled next to it. If the parts do not match, you will have trouble getting the e-ring installed.

WHEEL ADJUSTERS



Put wheel adjuster in a vise.

WHEEL ADJUSTERS

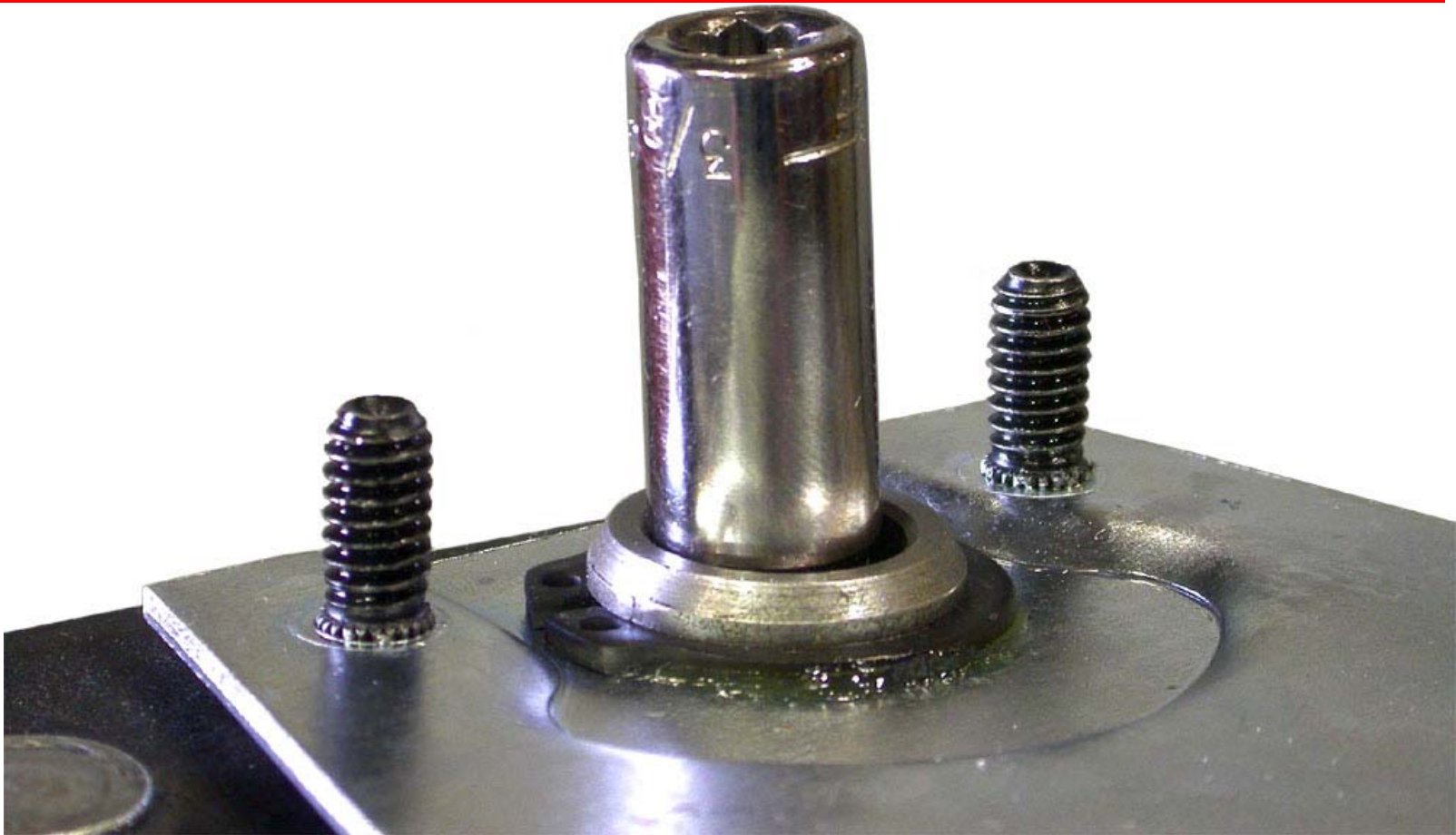

Use a 3/8 inch deep well socket and a hammer to remove the bearing.

WHEEL ADJUSTERS

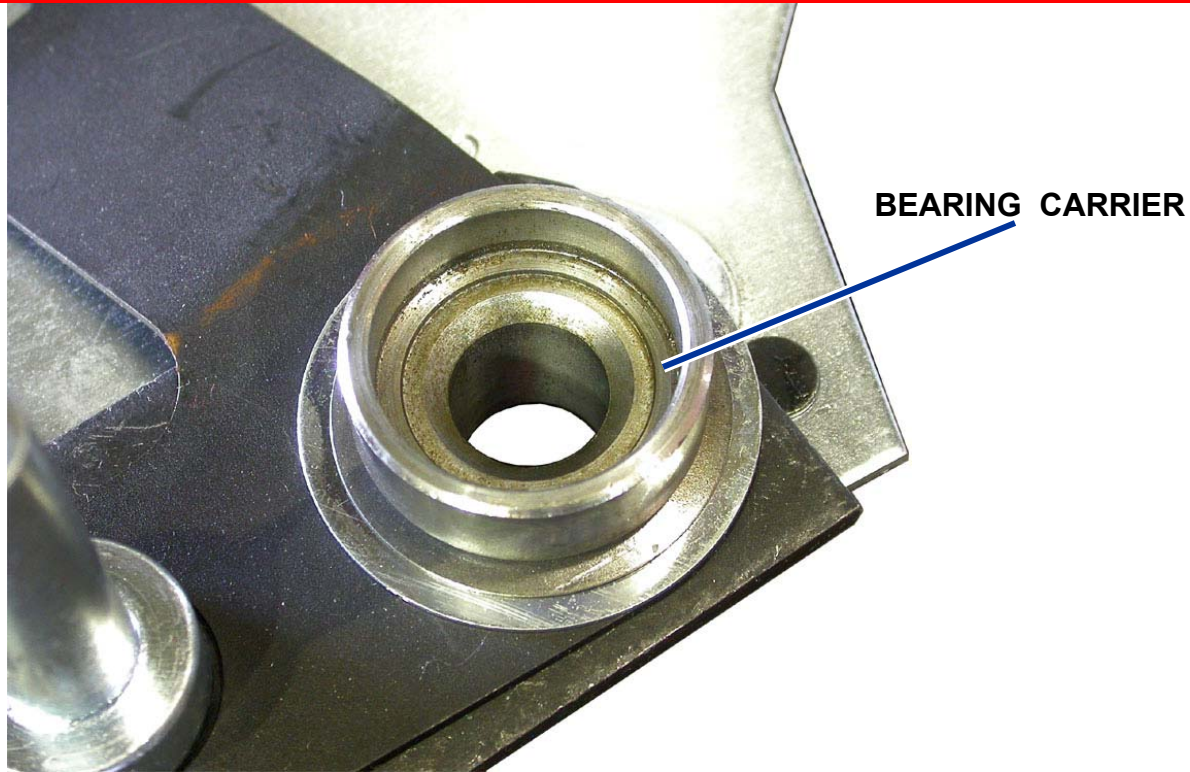

Inspect for any distortion or damage where the bearing carrier would be unusable.

WHEEL ADJUSTERS

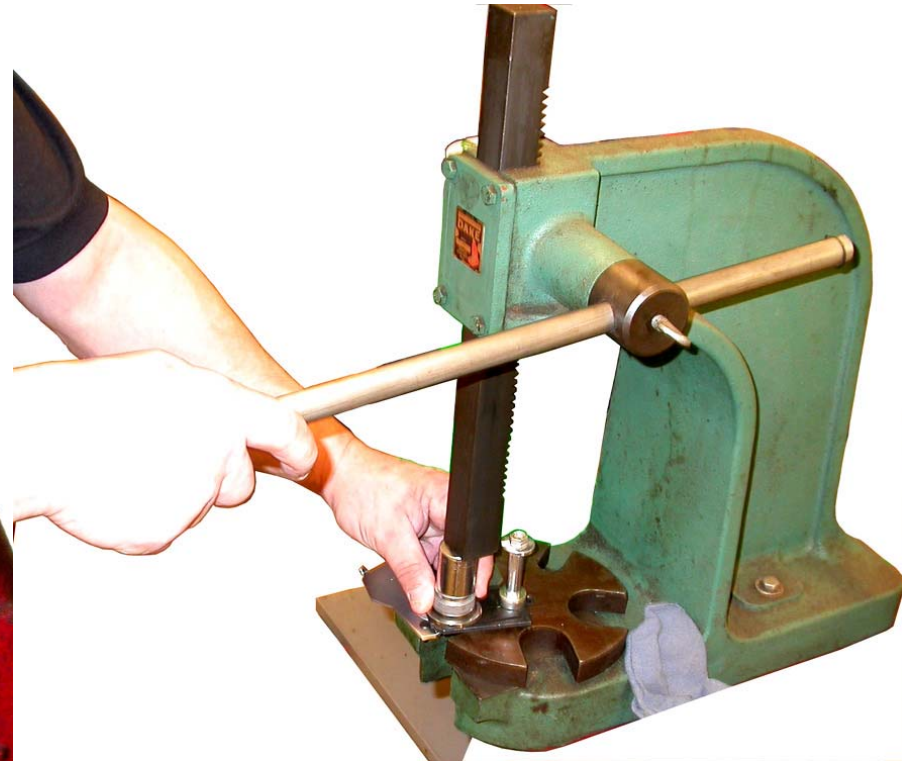
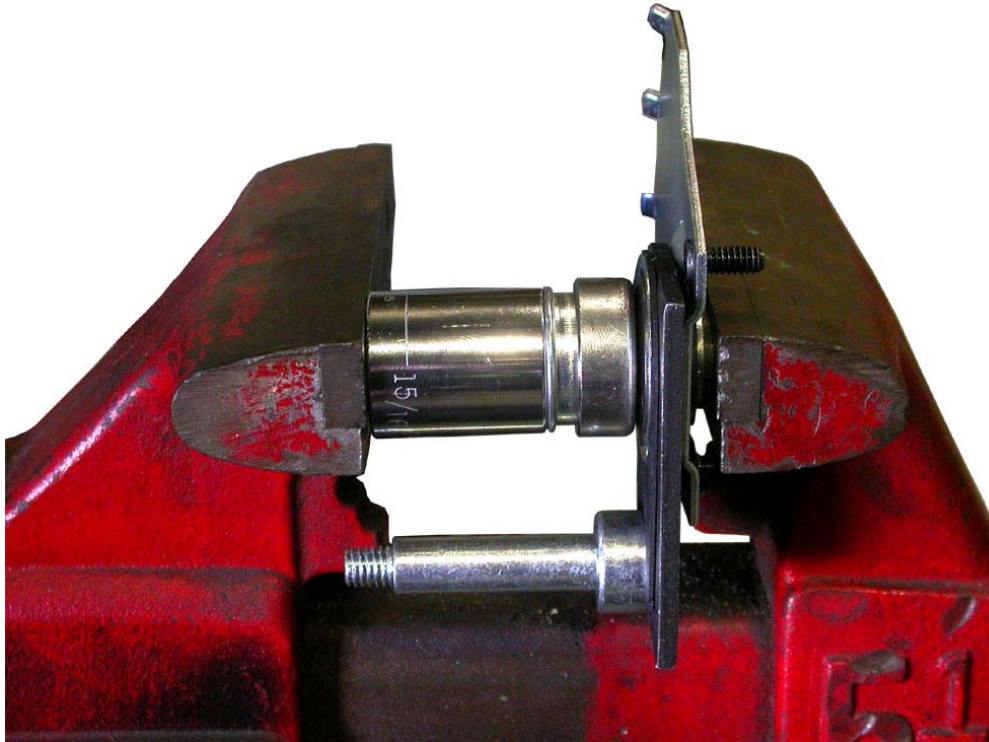

- Use a 15 / 16 inch socket to press in the bearing without damaging the bearing.
- An arbor press can also be used to install the bearing.

WHEEL ADJUSTERS

LEFT FRONT OR
RIGHT REAR
ADJUSTER



RIGHT FRONT OR
LEFT REAR
ADJUSTER



- These are the most common style of idler wheel adjusters used on Source 917 walk behind mowers.
- Left side and right side wheel adjusters are made from the same parts.
- The difference is how the adjuster is assembled.

WHEEL ADJUSTERS

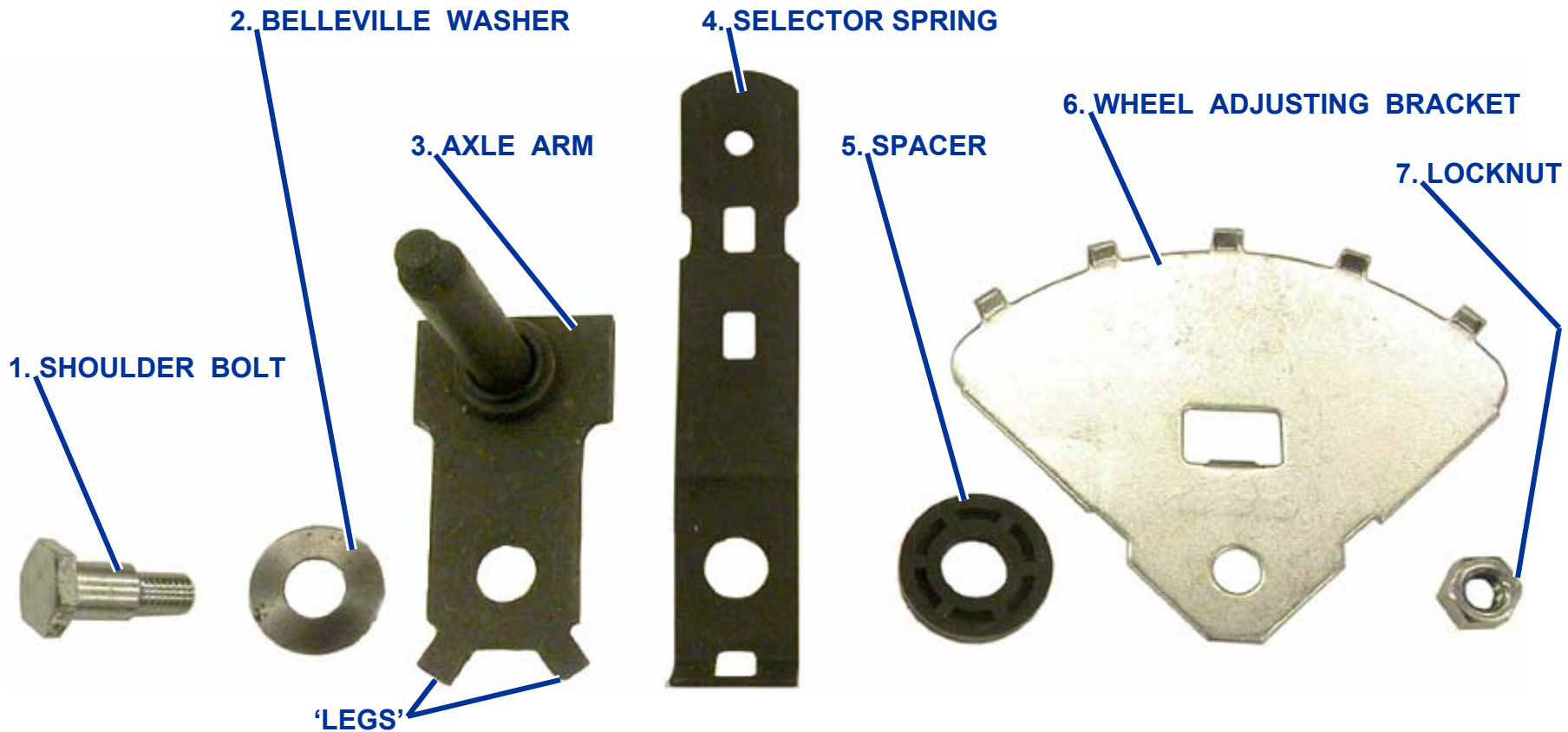

- Idler wheel adjusters like these are assembled in the above sequence.
- There are other ways to assemble the parts incorrectly
- There are two 'legs' on the axle arm
 - By assembling to the other 'leg' the direction of the adjuster is reversed.

WHEEL ADJUSTERS

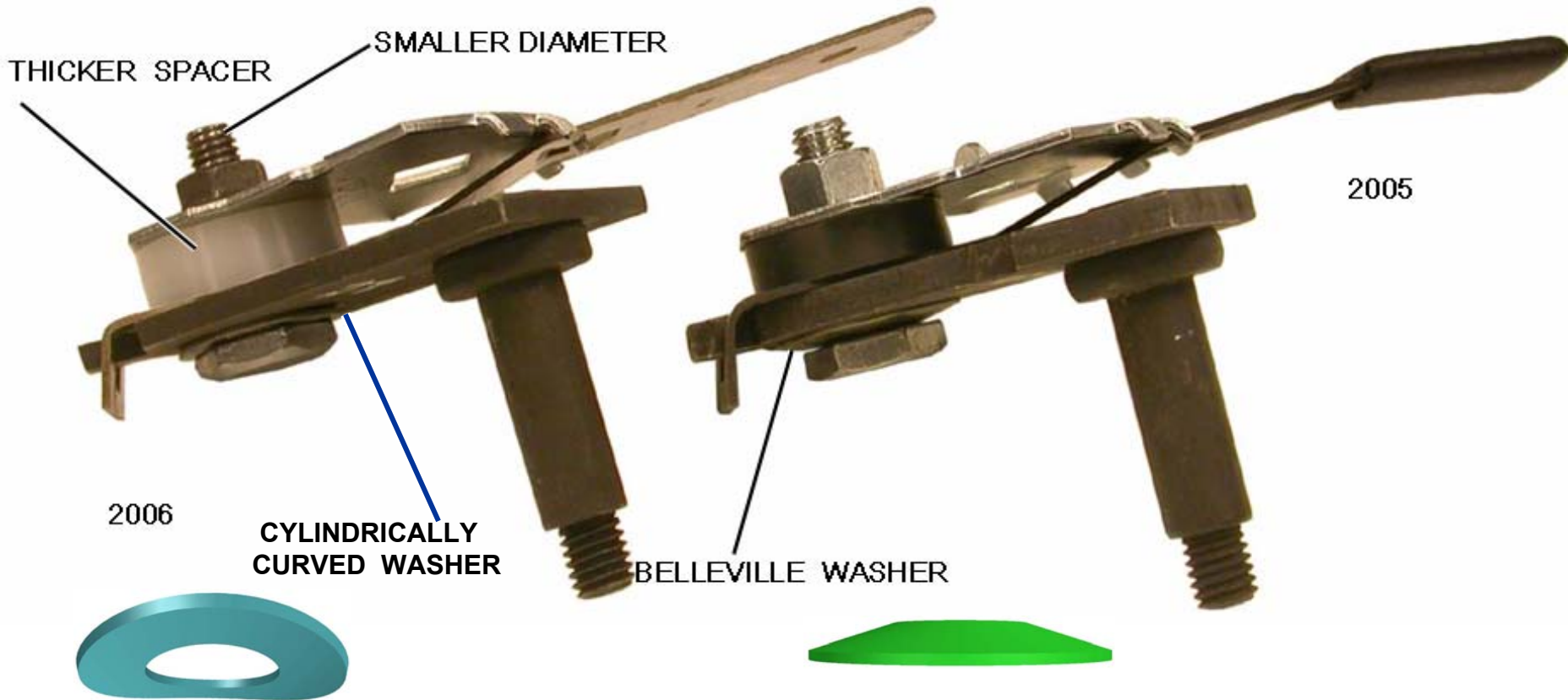

- In 2006 improvements were made to wheel adjusters.
- The parts are not interchangeable.
- Use only the parts specified in the parts list.
- The assembly sequence is the same.

WHEEL ADJUSTERS

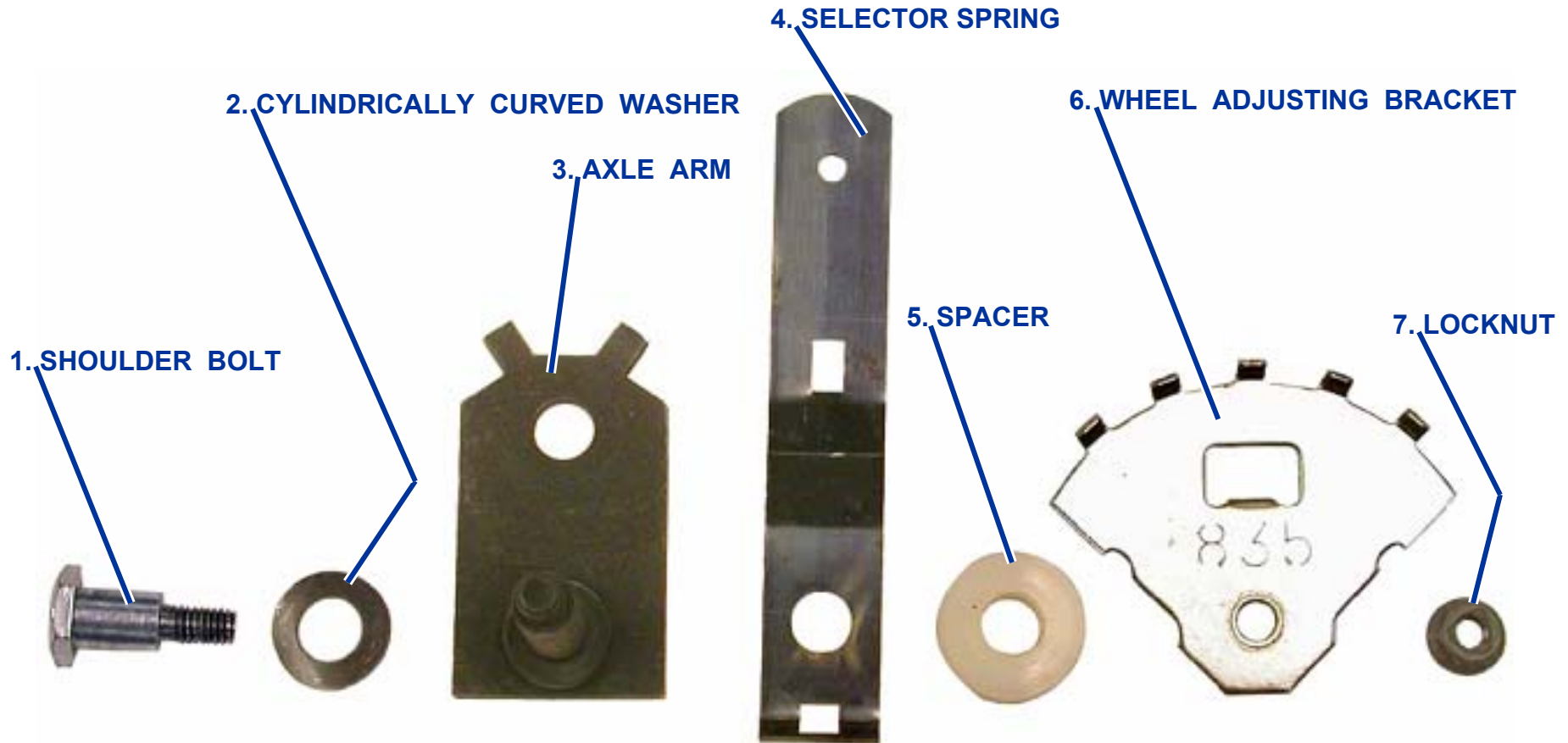

- Idler wheel adjusters for mowers 2006 and newer
- Assembly sequence