

PARTS AND SERVICE

This product has been expertly engineered and carefully manufactured to rigid quality standards. As with all mechanical products, some adjustments or part replacement may be necessary during the life of your unit.

For Parts and service, contact our authorized distributor: call 1-800-849-1297

- For replacement parts, have available the following information:
 - a. Model Number/Manufacturer's I.D. Number
 - b. Description of part.

For Technical Assistance: call 1-800-829-5886

For a Parts Manual, go to our website: www.weedeater.com

NOTE: HOP provides parts and service through its authorized distributors and dealers; therefore, all requests for parts and service should be directed to your local dealer(s). The philosophy of HOP is to continually improve all of its products. If the operating characteristics or the appearance of your product differs from those described in this Manual, please contact your local dealer for updated information and assistance.

L'ENTRETIEN ET LES PIÈCES DE RECHANGE

Ce produit, conçu avec les soins les plus attentifs, est fabriqué en accord avec des standards stricts. Comme pour tous les produits avec des parties mobiles, il peut être nécessaire pendant la durabilité de votre machine d'effectuer des ajustements ou le remplacement de certaines pièces.

Pour les pièces de rechange et l'entretien, contactez notre concessionnaire autorisé: appelez 1-800-849-1297

- Pour les pièces de rechange, ayez près de vous:
 - A. Numéro du modèle/Référence numéro du fabricant
 - B. Description de la pièce

Pour l'assistance technique: appelez 1-800-829-5886

Pour un manuel de pièces, allez à notre site web: www.weedeater.com

N.B.: HOP assure la distribution des pièces de rechange et l'entretien de ses produits par l'intermédiaire des concessionnaires et des distributeurs agréés; par conséquent toute demande de pièces ou d'entretien doit être adressée directement au distributeur agréé le plus proche. La philosophie de HOP est d'améliorer en permanence la gamme complète de ses produits. Si les caractéristiques ou l'apparence de votre outil sont différentes de celles décrites dans ce Manuel, contactez S.V.P. votre concessionnaire pour les informations et l'assistance concernant les mises à jour.

WEEDEATER®
One

WEEDEATER®
One



**PLEASE NOTE:
SOME DRAWINGS
AND
DESCRIPTIONS
ARE NOT ON THE
SAME PAGE ON
THIS IPL**

**Repair Parts Manual
Manuel Des Pièces**
WE261 / 96028000103



Please read the operator's manual carefully and make sure you understand the instructions before using the machine.

Lire et suivre toutes les règles de sécurité et les consignes avant d'opérer cet équipement.

Patents Pending

HOW TO USE THIS MANUAL

This manual is designed to provide the customer with a means to identify the parts on his/her tractor when ordering repair parts. The illustrations may or may not represent the actual assemblies; therefore, it is not recommended to use this manual as a guide to assemble or disassemble the tractor. Some hardware and parts are drawn larger in order to more readily identify them.

Each tractor has its own model number.

The model number for your tractor can be found on the fender under the seat.

When ordering parts, always give the following information:

- Product - "TRACTOR"
- MODEL NUMBER - "WE261" (96028000103)"
- Part Number
- Part Description

TABLE OF CONTENTS

SCHEMATIC..... 3
 ELECTRICAL..... 4-5
 CHASSIS..... 6-7
 DRIVE..... 8-9
 STEERING..... 10-11
 MOWER DECK..... 12-13
 DECAL..... 14
 PARTS AND SERVICE..... BACK PAGE

COMMENT UTILISER CE MANUEL

Ce manuel a été dessiné pour fournir le client avec les moyens d'identification des pièces de détachées du tracteur quand il/elle a besoin de commander les pièces de rechange. Les illustrations ne peuvent pas représenter exactement le modèle que vous avez acheté. N'utilisez pas ce manuel comme un guide dans le montage et/ou démontage de votre tracteur. La visserie montrée est plus grande pour faciliter l'identification.

Chaque tracteur a un numéro de modèle particulier.

Le numéro de modèle du produit se trouvera sur l'aile, dessous le siège.

Lorsque vous commandez des pièces de rechange, donnez toujours les renseignements suivants:

- Produit - "Tracteur"
- NUMÉRO DU MODÈLE - "WE261 (96028000103)"
- Numéro de la Pièce
- Description de la Pièce

TABLE DE MATIERES

SCHÉMA..... 15
 ELECTRIQUE..... 16-17
 CHÂSSIS/ENCEINTES..... 18-19
 ENTRAÎNEMENT..... 20-21
 ENSEMBLE DE LA DIRECTION..... 22-23
 PLATEAU DE COUPE..... 24-25
 DECALCOMANIES 26
 L'ENTRETIEN ET LES PIÈCES DE RECHANGE..... VERSO DE LA PAGE

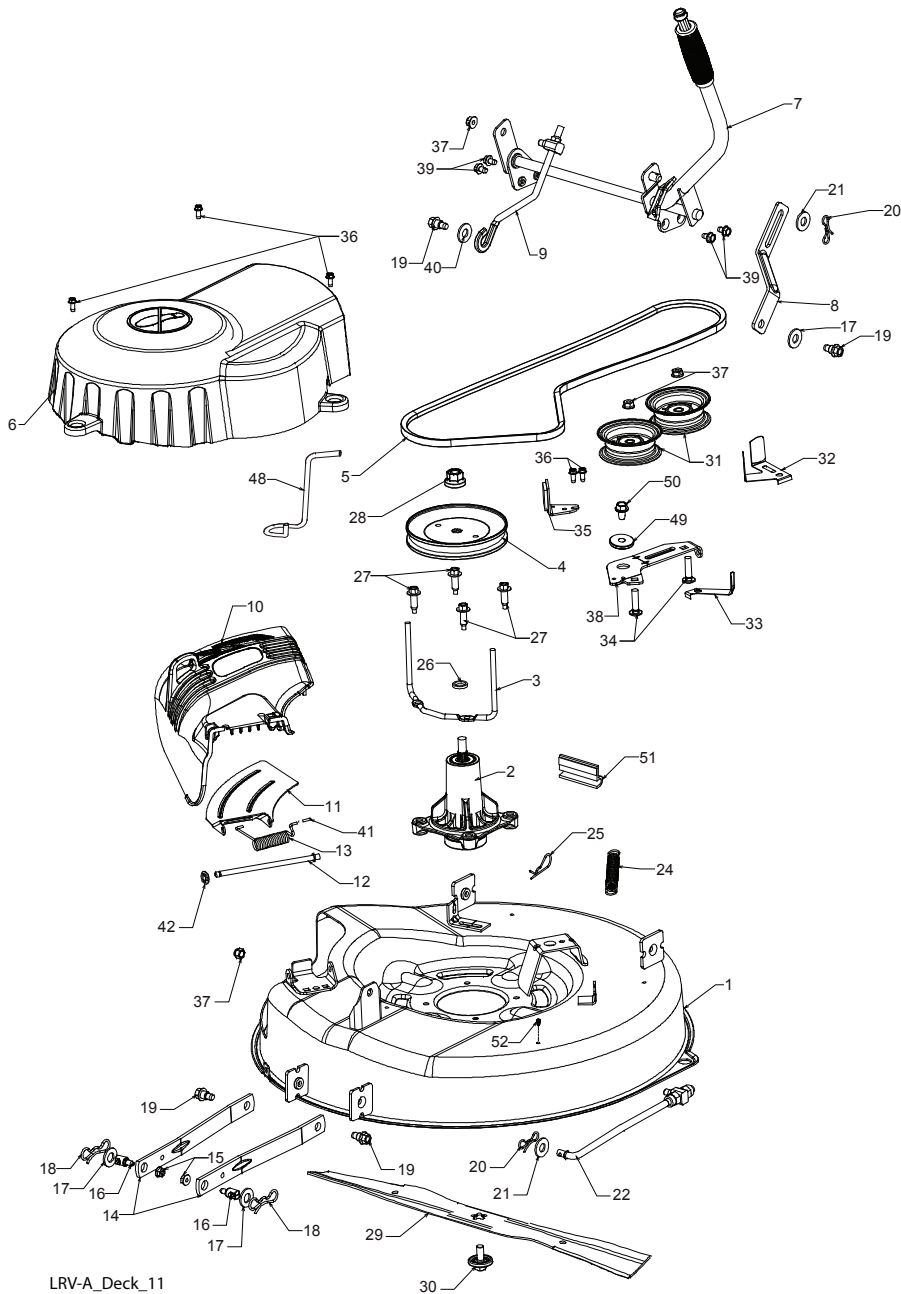

LRV-A_Deck_11

ELECTRICAL PARTS

KEY PART NO. NO.

DESCRIPTION

1	532 43 70-70	BATTERY
2	532 42 54-16	FOAM, POLYURETHANE
3	532 19 33-50	SWITCH, IGN, DLTA, P-IN, ROS
4	532 41 19-33	KEY/CHAIN
5	532 43 33-30	FUSE, 5A
6	532 42 59-37	FUSE, 40A
7	532 16 07-84	SWITCH, PLUNGER, NO, OLIVE
8	532 43 15-42	RELAY, 40A
9	532 10 95-53	SWITCH, INTLK,CL, MWR, GRY
10	532 17 61-38	SWITCH, INTERLOCK, NONC,GRAY
11	532 43 18-46	MODULE, STARTING, RECOIL, LRV
12	532 19 27-49	SWITCH, SEAT, DP, ROS
13	532 42 84-77	HARNESS, IGN, ELECTSTART, LRV
14	532 10 97-48	RELAY

NOTE: All component dimensions given in U.S. inches
1 inch = 25.4 mm

FRAME, ENGINE, SEAT PARTS

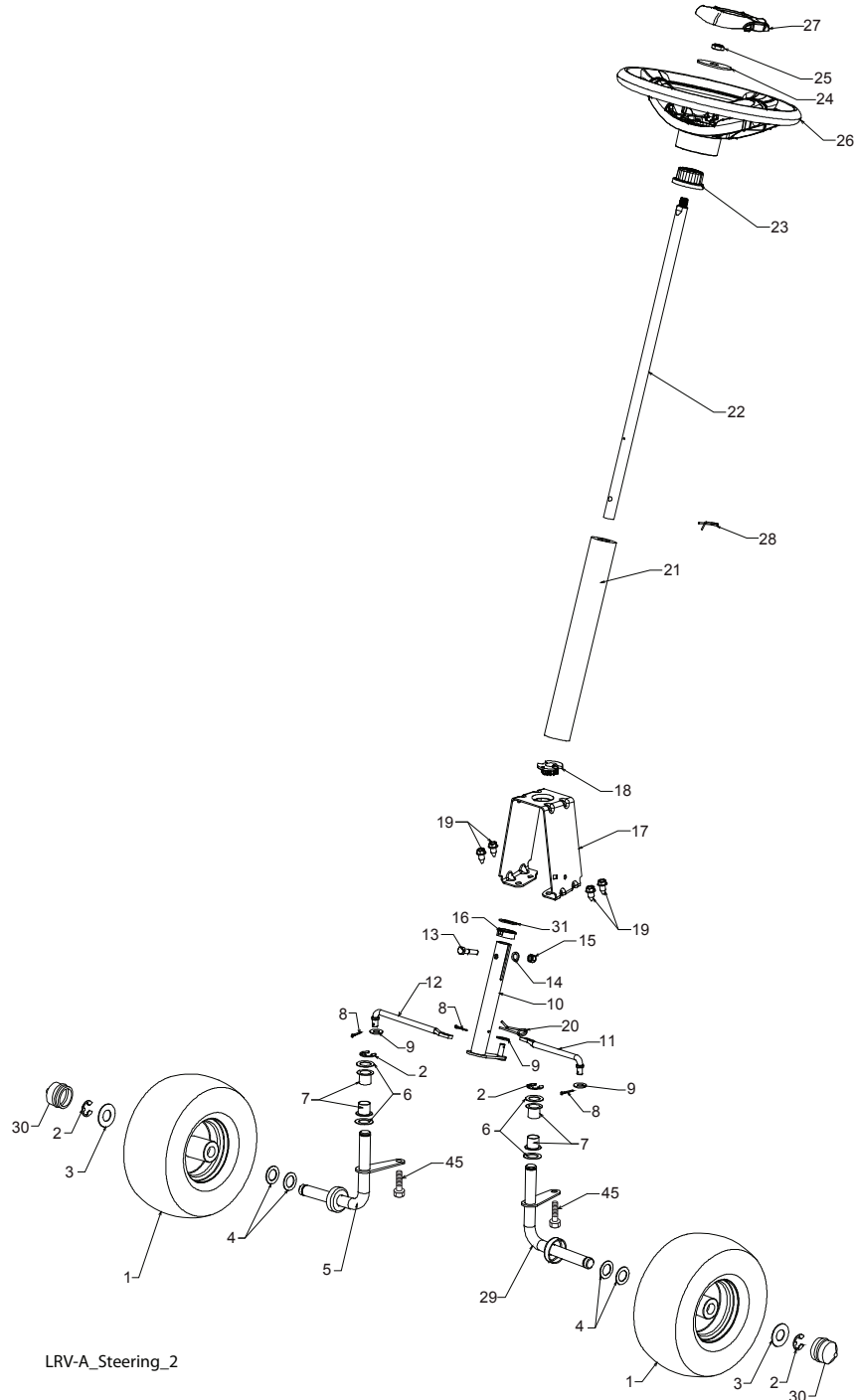

LRV-A_Steering_2

KEY PART NO.	NO.	DESCRIPTION
1	532 42 80-48	WELDMENT, CHASSIS
2	532 43 98-16	SUPPORT, AXLE RH
3	532 43 98-12	SUPPORT, AXLE LH
4	532 42 83-46	SHIELD, TRANSAXLE FRONT
5	532 42 81-10	BRACE, AXLE CROSS
6	532 42 81-09	COVER, FRICTION DRIVE
7	532 42 80-40	PLATE, ENGINE
8	532 42 85-76	BRACKET, CHASSIS FRONT
9	532 42 88-56	BRACKET, STEERING SUPPORT
10	532 19 55-30	PAN, SEAT
11	532 17 46-48	BRACKET, SWITCH MOUNTING
12	532 42 82-48	BOOT, DUST
13	532 43 64-96	COVER, FOOT REST
14	532 42 82-50	STRUCTURE, FOOT REST
15	532 42 82-49	SUPPORT, FOOT REST
16	532 43 64-97	FENDER, CONTROL
17	532 42 83-48	GUARD, ENGINE
18	-----	ENGINE 12S907-1463-B1 (435674) (ORDER PARTS FROM ENGINE MANUFACTURER.)
19	532 42 89-86	KEEPER, BELT
20	532 42 80-46	BRACKET, BATTERY
21	532 42 98-15	LEVER, SWITCH
22	532 42 88-26	DECK CLUTCH ASM
23	532 14 98-46	KNOB
24	532 41 63-58	SCREW, NO. 10
25	872 14 04-24	BOLT, CARRIAGE 1/4-20 X 3
26	873 51 04-00	NUT, 1/4-20
27	532 43 00-87	SPACER, ENGINE
28	532 42 83-01	DISC, FRICTION ASM
29	532 43 08-17	BOLT, SCKT HD 3/8-24 X 1 .25
30	532 43 04-70	BEARING
31	532 43 73-22	SPACER, NEUTRAL
32	532 15 04-06	BOLT 3/8-16 X 1.280
33	532 12 41-81	SPRING, SEAT
34	532 12 12-50	SPRING
35	872 05 04-12	BOLT, 1/4-20 X 1 1/2
36	532 12 70-18	BOLT, SHOULDER
37	819 17 19-12	WASHER, 17/32 X 1 3/16
38	532 16 63-69	KNOB, SEAT
39	532 13 43-00	SPACER
40	532 12 12-48	BUSHING, NYLON SNAP
41	532 12 39-76	NUT, LOCK
42	532 17 18-52	BOLT, 5/16-18 SHOULDER
43	873 80 05-00	NUT, 5/16-18
44	532 44 06-91	SEAT
45	817 00 05-12	BOLT, 5/16-18 X 3/4
46	817 49 05-08	BOLT, 5/16-18 X 1/2
47	532 08 67-77	SCREW
48	532 40 89-81	BEARING, FLANGE, BALL
49	817 06 05-16	SCREW, 5/16-18 X1
50	532 16 54-92	BOLT, SHOULDER, 5/16-18 X .561
52	532 14 50-06	CLIP PUSH-IN HINGED

NOTE: All component dimensions given in U.S. inches
1 inch = 25.4 mm

DRIVE (TRANSMISSION)
PARTS

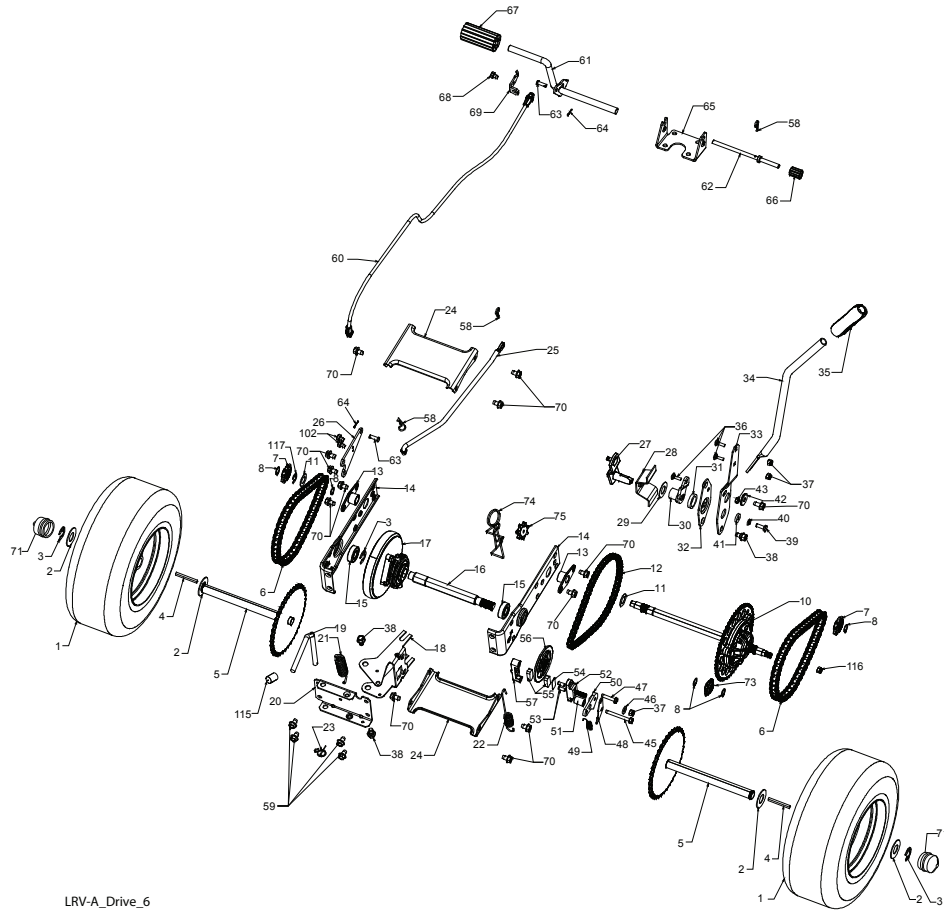

LRV-A_Drive_6

KEY PART NO.	NO.	DESCRIPTION	KEY PART NO.	NO.	DESCRIPTION
--	532 43 61-44	SERVICE KIT, TRANSAXLE	42	532 16 60-02	WASHER, SERRATED
1	532 43 64-98	WHEEL ASM (REAR)	43	873 68 04-00	NUT, CROWN LOCK 1 1/4-20
2	532 12 17-48	WASHER, 16 GA.	45	817 49 04-36	SCREW 1/4-20 X 2 114
3	812 00 00-01	E-CLIP	46	819 09 10-16	WASHER
4	532 12 35-83	KEY, SQUARE	47	817 49 04-20	SCREW, 1/4-20 X 1 1/2
5	532 42 79-39	WELDMNT. DRIVE AXLE	48	532 43 02-49	PLATE BRAKE ANTI - ROTATE
6	532 42 80-69	CHAIN DRIVE	49	532 43 02-45	SPRING, BRAKE RETURN
7	532 42 78-73	SPROCKET. 9 TOOTH SPLINED	50	532 42 80-21	ARM, BRAKE
8	812 10 00-09	RING, SNAP	51	532 43 02-47	SPACER RETURN
10	532 42 88-76	DIFFERENTIAL ASM	52	532 42 80-78	CALIPER, BRAKE ASM
11	532 00 13-70	WASHER, THRUST	53	877 01 08-10	PIN, DOWEL 1/4
12	532 43 06-45	CHAIN, PRIMARY DRIVE	54	532 42 80-19	PLATE, BRAKE PAD
13	532 43 08-45	BUSHING	55	532 42 80-17	PUCK BRAKE
14	532 43 85-68	BRACKET, CARRIER	56	532 43 52-53	ROTOR, BRAKE
15	532 12 47-93	BEARING ASM	57	532 42 80-16	CAP, BRAKE CALIPER
16	532 42 79-26	SHAFT INPUT	58	532 12 47-88	PIN, RETAINER
17	532 43 72-81	WHEEL, FRICTION A5M	59	817 49 05-08	BOLT, 5/16-16 X 1 1/2
18	532 42 47-59	ARM, SHIFT	60	532 44 08-55	CABLE, BRAKE
19	532 43 08-70	ROD, BYPASS	61	532 42 79-45	WELDMENT, PEDAL
20	532 42 79-97	BRACE CARRIER REAR	62	532 42 96-78	ROD, PARKING BRAKE
21	532 42 80-77	SPRING, CARRIER	63	877 10 08-12	PIN, .25 X .75 CLEVIS
22	532 42 80-76	SPRING, BRAKE	64	532 42 10-76	PIN, COTTER 5/64 X 3/4
23	532 43 13-74	SPRING, BYPASS	65	532 42 93-25	BRACKET, BRAKE SUPPORT
24	532 42 79-95	BRACE CARRIER BOX	66	532 42 96-94	COVER PEDAL
25	532 42 83-03	LINK, SHIFT	67	532 42 96-93	COVER, BRAKE PEDAL
26	532 42 98-16	ARM, CLUTCH	68	817 49 04-06	SCREW, 1/4-20 X 3/8
27	532 42 90-53	WELDMENT SHIFT LEVER	69	532 42 80-70	BRAKE CABLE MOUNT
28	532 42 83-02	SUPPORT, SHIFT LEVER	70	817 00 05-12	BOLT, 5/16-18 X 3/4
29	532 17 48-40	WASHER, NYLON	71	532 43 64-99	CAP HUB AXLE
30	532 44 43-04	HUB SHIFT LEVER	73	532 42 95-19	SPROCKET II TOOTH SPLINED
31	532 42 90-55	SPACER, NYLON	74	532 43 78-41	TENSION LRV CHAIN
32	532 42 84-64	MNTG BRKT. SHIFT ARM	75	532 43 34-95	SPROCKET IDLER
33	532 42 84-61	BRACKET, SHIFTER FLEX	102	532 08 67-77	THREAD CUTTER
34	532 42 84-62	TUBE SHIFT ARM	115	532 14 00-62	CAP PLUNGER
35	532 41 15-55	GRIP, HANDLE	116	873 90 06-00	NUT LOCK FLG 3/8-16 UNC
36	872 11 04-06	BOLT, CARRIAGE -1 1/4-20X3/4	117	812 00 00-40	RING KLIP #T5304-62
37	873 80 04-00	NUT NYLON LOCK 1 1/4-20			
38	532 16 54-92	BOLT, SHOULDER			
39	874 78 04-12	BOLT, 1/4-20 X 3/4			
40	810 04 04-00	WASHER, LOCK			
41	819 09 12-10	WASHER FLAT			

NOTE: All component dimensions given in U.S. inches
1 inch = 25.4 mm

STEERING PARTS

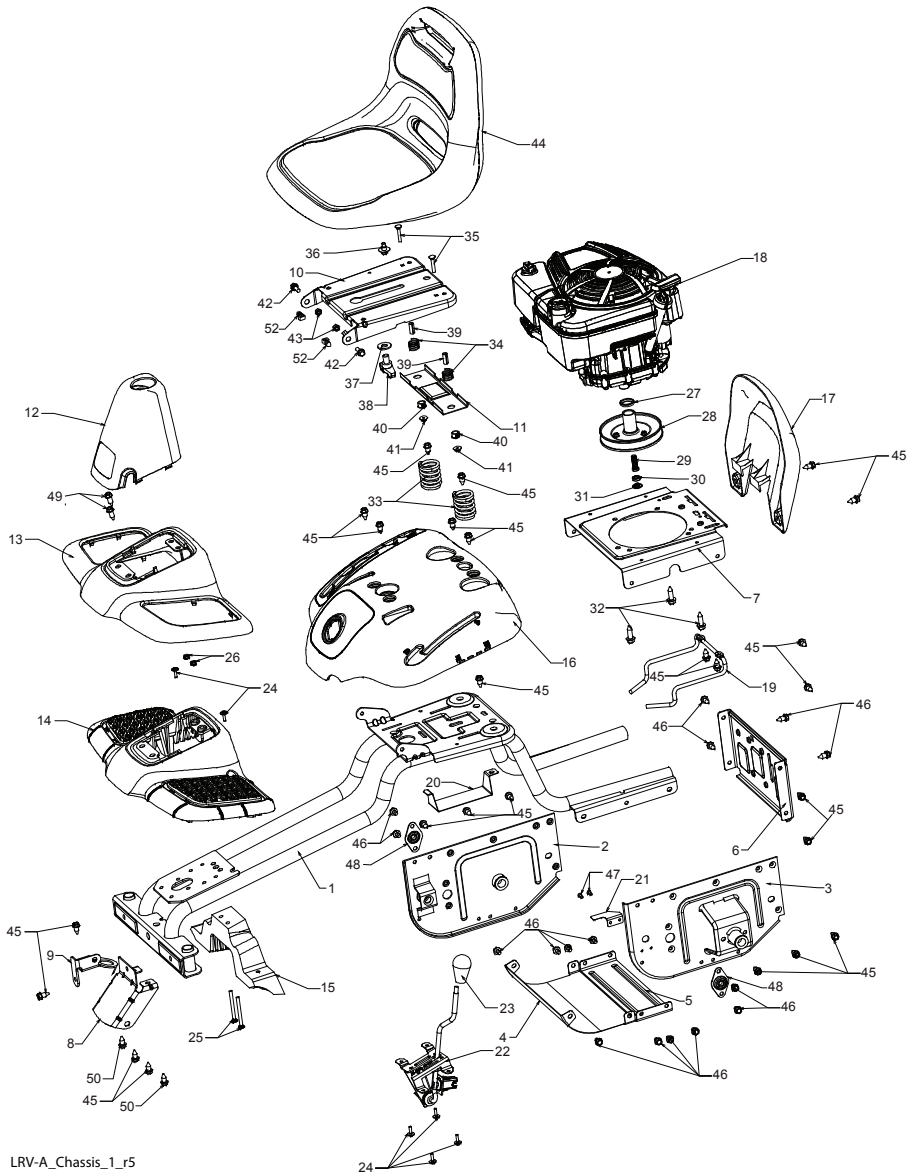

KEY NO.	PART NO.	DESCRIPTION
1	532 43 65-00	WHEEL ASM (FRONT)
2	812 00 00-01	E-CLIP
3	532 18 89-67	WASHER, HARDENED
4	532 12 17-49	WASHER, 1/4 X 3/4
5	532 43 53-24	SPINDLE, RH
6	532 12 49-31	WASHER, HARDENED THRUST
7	532 12 49-37	BUSHING, STEERING COLUMN
8	532 42 10-76	PIN, 5/64 X 3/4 COTTER
9	819 13 14-14	WASHER
10	532 42 80-57	WELDMENT, LWR STRG SHAFT
11	532 42 80-35	LINK, STRNG LH
12	532 42 80-36	LINK, STRNG RH
13	874 78 05-24	BOLT, 5/16-18 X 1 1/2
14	819 13 10-16	WASHER
15	873 80 05-00	NUT, 5/16-18
16	532 42 80-44	BUSHING, STEERING SNAP
17	532 42 82-52	SUPPORT, UPPER STEERING
18	532 19 52-27	BUSHING, UPPER STEERING
19	817 00 05-12	BOLT, 5/16-18 X 3/4
20	532 42 80-45	CLIP, RETAINER SPRING
21	532 42 83-47	COVER, STEERING COLUMN
22	532 42 82-13	SHAFT, STEERING
23	532 43 77-47	ADAPTER, STEERING WHEEL
24	819 18 38-12	WASHER, 9/16 X 2 3/8 12 GA.
25	873 94 08-00	NUT, JAM LOCK 1/2-20
26	532 44 16-14	WHEEL, STEERING
27	532 44 16-15	CAP, STEERING WHEEL
28	532 19 98-49	CLIP, RETAINER SPRING
29	532 43 53-23	SPINDLE, LH
30	532 43 64-99	CAP, HUB, AXLE
31	819 34 32-10	WASHER 1-1/16 X 2 X 10 GA
45	532 16 54-92	BOLT SHOULDER 5/16-18 X .561

NOTE: All component dimensions given in U.S. inches
1 inch = 25.4 mm

Deck Parts

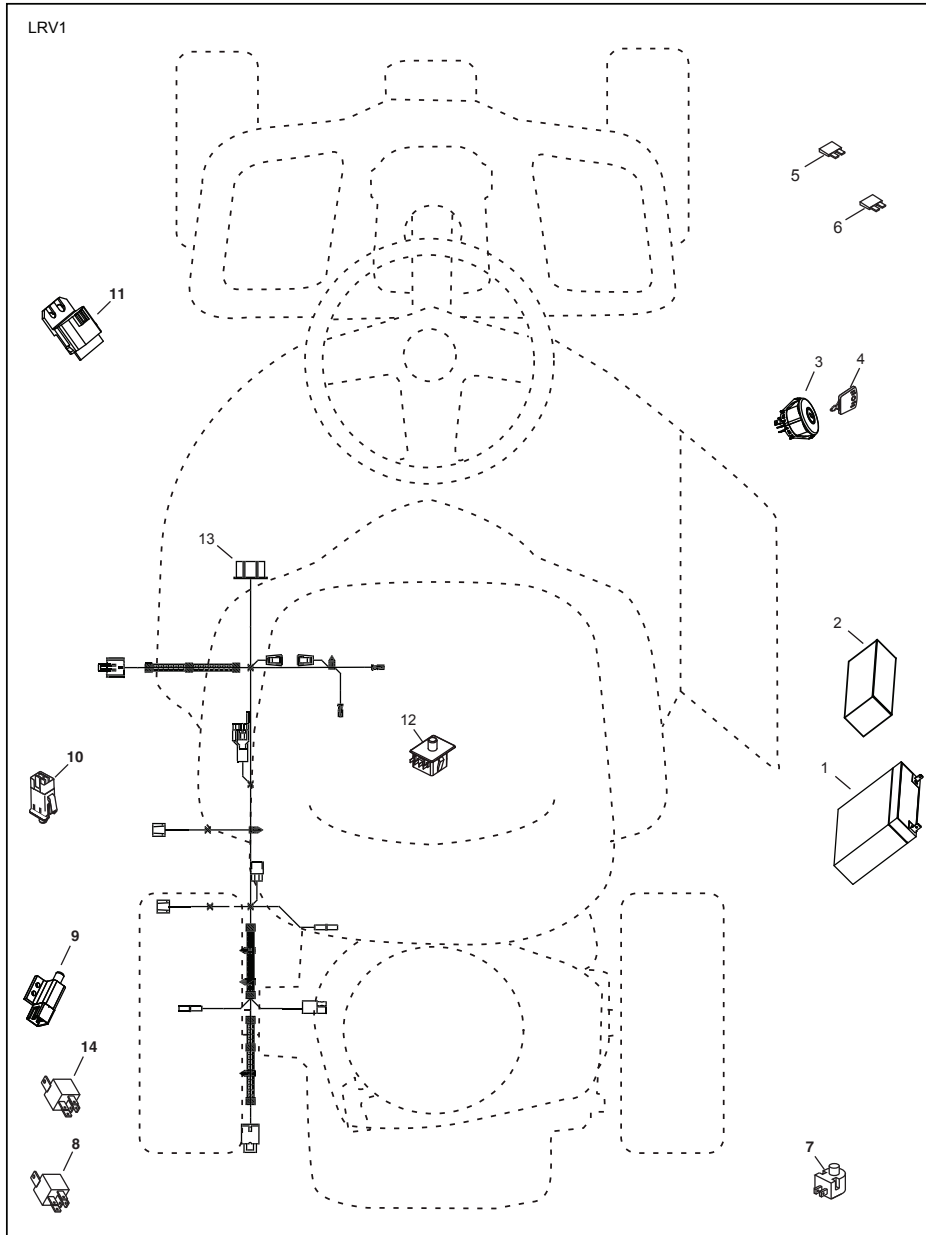

KEY NO.	PART NO.	DESCRIPTION
1	532 42 81-93	DECK, 26"
2	532 19 28-70	MANDREL ASM
3	532 43 25-20	KEEPER, BELT
4	532 43 25-94	PULLEY, MANDREL
5	532 42 85-78	BELT
6	532 42 82-42	COVER, MANDREL
7	532 43 86-91	LIFT ASM, DECK
8	532 42 91-95	LINK, DECK LIFT
9	532 42 93-97	LINK, ADJUSTABLE
10	532 43 89-23	DEFLECTOR
11	532 42 89-68	SUPPORT, DEFLECTOR
12	532 13 14-91	ROD, HINGE
13	532 19 70-26	SPRING, TORSION
14	532 41 88-63	ARM, MOWER SUPPORT
15	873 90 05-00	NUT, LOCK
16	532 19 51-61	STUD
17	819 19 19-12	WASHER
18	532 19 42-09	PIN
19	532 19 65-39	BOLT, SHOULDER
20	532 19 42-08	PIN
21	819 17 19-12	WASHER, 17/32 X 1 3/16
22	532 42 93-50	LINK, DECK
24	532 42 95-31	SPRING, DECK
25	532 12 47-88	PIN
26	532 18 76-90	SPACER, MANDREL
27	532 17 39-84	BOLT, MANDREL
28	532 40 02-34	NUT, LOCK
29	532 42 85-00	BLADE
30	532 19 30-03	BOLT, BLADE
31	532 19 31-97	PULLEY, IDLER
32	532 14 10-43	GUARD, IDLER
33	532 19 34-14	KEEPER, BELT IDLER
34	872 11 06-12	BOLT, 3/8-16 X 1 1/2
35	532 19 94-70	ARM, BRAKE
36	532 13 77-29	SCREW, 1/4-20 X 5/8
37	873 90 06-00	NUT, 3/8-16 FLANGE
38	532 42 84-35	ARM, IDLER
39	817 49 05-08	BOLT, 5/16-18 X 1/2
40	819 17 16-16	WASHER, 16 GA.
41	532 10 53-04	CAP, SLEEVE
42	532 11 04-52	NUT, PUSH
48	532 43 86-10	KEEPER BELT
49	532 19 90-92	SPACER RETAINER
50	817 00 06-16	SCREW 3/8-16 X 1
51	532 40 47-42	BUMPER
52	817 67 06-08	SCREW 3/8-16 X 1/2

NOTE: All component dimensions given in U.S. inches
1 inch = 25.4 mm

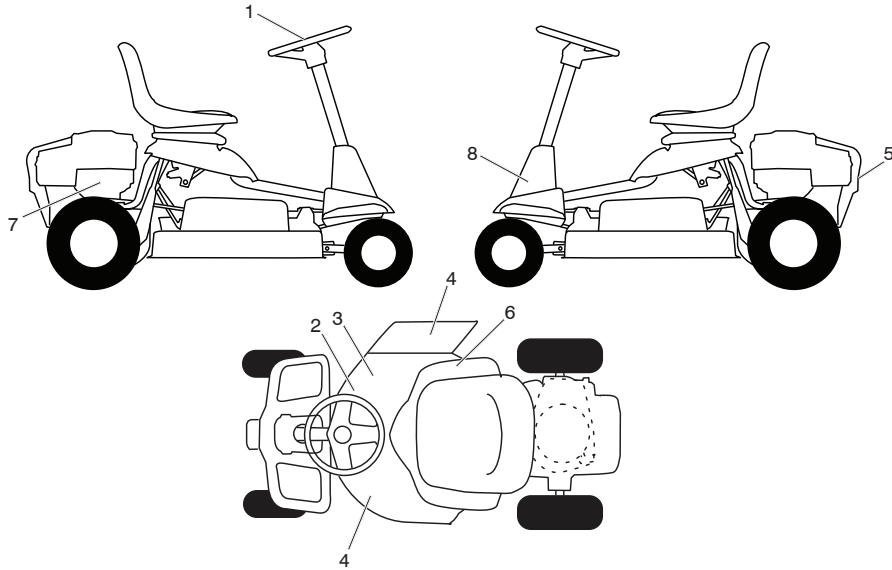

KEY PART NO.	NO.	DESCRIPTION
1	532 43 05-88	DECAL, STEERING WHEEL
2	532 43 35-96	DECAL, V-BELT SCH 30"
3	532 42 51-13	DECAL, WARN. DEFLECT/CTFGR
4	532 44 07-79	DECAL, DECK/DEFLECTOR
5	532 43 57-08	DECAL, WARN. ENGINEGUARD
6	532 43 67-55	DECAL
7	532 43 52-86	DECAL, WARNING SPARK ARRESTOR
8	532 43 73-12	DECAL, STEERING BRKT INSTALL
--	532 43 24-79	DECAL, BYPASS
--	580 30 37-26	MANUAL OPERATOR'S ENGLISH/FRENCH
--	580 30 84-26	MANUAL PART'S ENGLISH/FRENCH

NOTE: All component dimensions given in U.S. inches
1 inch = 25.4 mm

SCH21-f

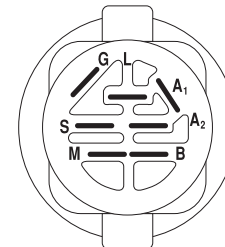
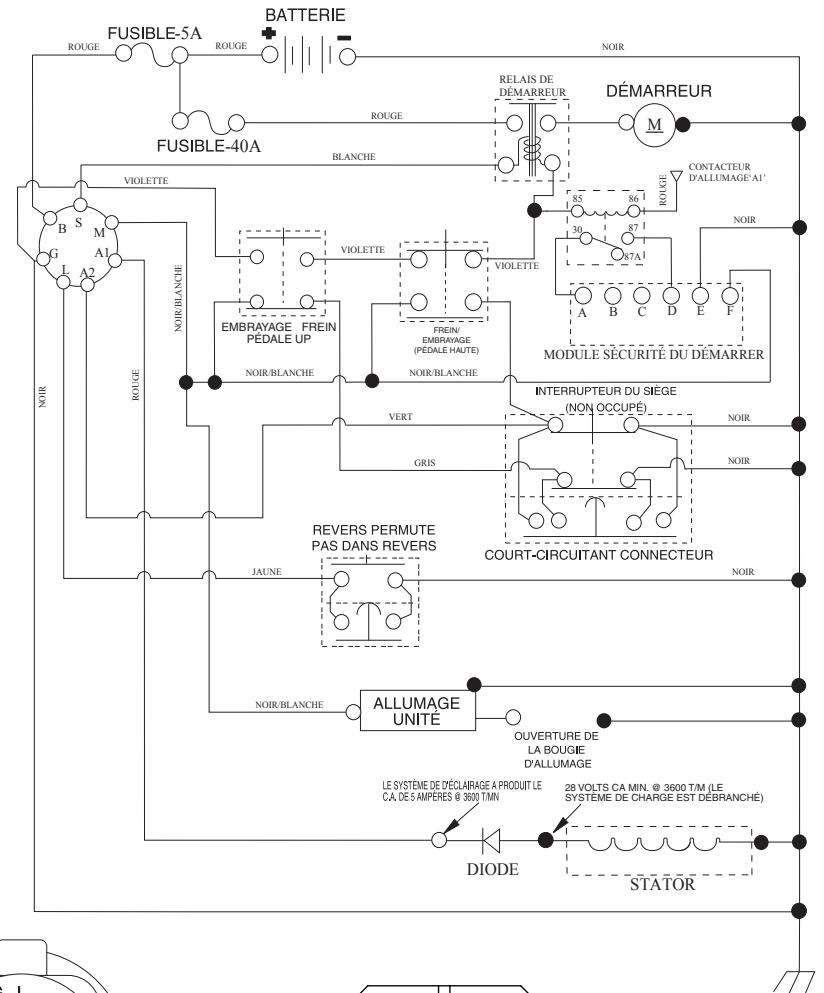

CONTACTEUR D'ALLUMAGE

POSITION	CIRCUIT "FAITS"
ARRÊT	M+G+A1
MARCHE/ALLUMAGE	B+A1
MARCHE	B+A1 L+A2
DÉMARRAGE	B + S + A1

PINCES ISOLÉES
REMARQUE: SI LES PINCES
ISOLÉES ONT ÉTÉ ENLEVÉES POUR L'ENTRETIEN DU MODÈLE,
ELLES DOIVENT ÊTRE REMISES EN PLACE POUR ASSURER LE
BON FONCTIONNEMENT DU CÂBLAGE.

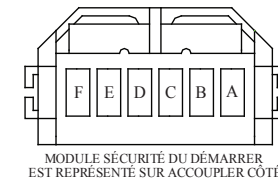

MODULE SÉCURITÉ DU DÉMARRER
EST REPRÉSENTÉ SUR ACCOUPLES CÔTÉ

AMOVIBLES
CONNECTEURS

NON-AMOVIBLES
CONNECTEURS