

TRACTOR -- MODEL NUMBER CHD14542A

CHASSIS AND ENCLOSURES

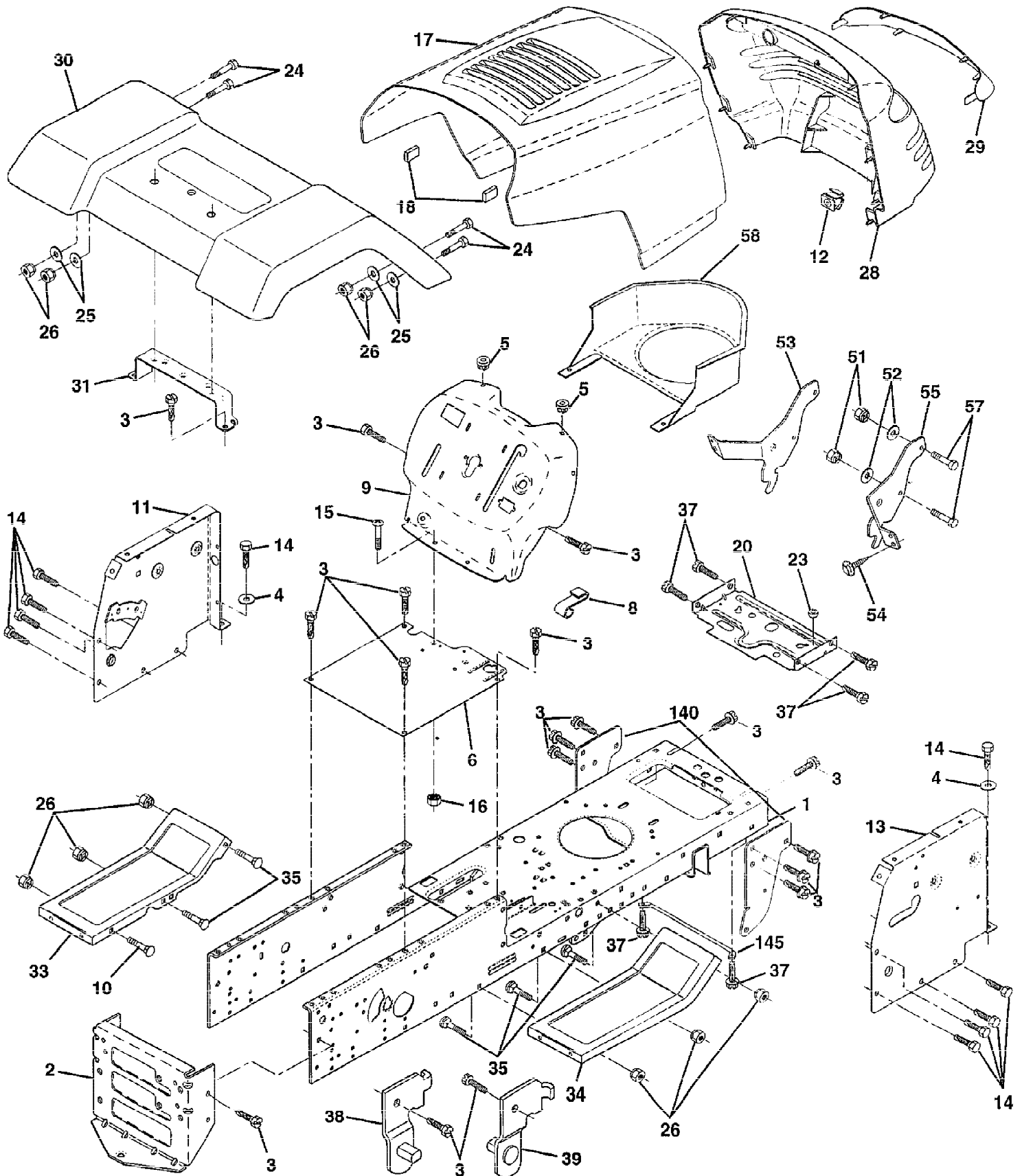

| Ref # | Part Number | Qty | Description |
|-------|-------------|-----|---------------------------|
| 1 | 165480 | | CHASSIS.STAMPING |
| 2 | 140356 | | SUB= 145009 |
| 3 | 17490612 | | SCREW |
| 4 | 19131216 | | WASHER |
| 5 | 155272 | | BUMPER-HOOD/DASH |
| 6 | 155923 | | SADDLE |
| 8 | 155138 | | CLIP.RETAINER |
| 9 | 161937X011 | | DASH SILKSCREEN |
| 10 | 72140608 | | SUB= 72110608 |
| 11 | 155927 | | "PANEL-DASH,LH" |
| 12 | 145660 | | CLIP.TINNERMAN |
| 13 | 169117X010 | | PANEL.ASM.SLKSCR.DASH.RH |
| 14 | 17490608 | | SCREW LT |
| 15 | 74180512 | | SCREW |
| 16 | 73510500 | | NUT |
| 17 | 159639X428 | | "HOOD W/TRIM,MS428" |
| 18 | 126938X | | SUB= 532126938 |
| 20 | 156437 | | "PLATE-MTG,BATT/FU" |
| 23 | 124028X | | SUB= 532124028 |
| 24 | 74780616 | | BOLT |
| 25 | 19131312 | | WASHER |
| 26 | 73800600 | | NUT |
| 28 | 157373 | | GRILLE-MS428 |
| 29 | 140273X599 | | LENS.GRILLE.PRIVATE LABEL |
| 30 | 166886X428 | | FENDER ASM. |
| 31 | 136619 | | BRKT FENDER |
| 33 | 105476X428 | | FOOTREST LH |
| 34 | 105475X428 | | FOOTREST RH |
| 35 | 72110606 | | BOLT |
| 37 | 17490508 | | SCREW LT |
| 38 | 139886 | | BRACKET ASM LH |
| 39 | 139887 | | BRACKET ASM RH |
| 51 | 73800400 | | NUT |
| 52 | 19091416 | | WASHER |
| 53 | 144697 | | BRACKET.GRILLE.LH |
| 54 | 161464 | | SCREW.HEX.WS.HD |
| 55 | 144696 | | BRACKET.GRILLE.RH |
| 57 | 74780412 | | SUB= 74780414 |
| 58 | 150127 | | AIR DUCT |
| 140 | 158418 | | BRKT SUSPENSION |
| 145 | 156524 | | "ROD POVOT,CHASSIS" |
| | 5479J | | PLUG BUTTON T |

TRACTOR - - MODEL NUMBER CHD14542A

DECALS

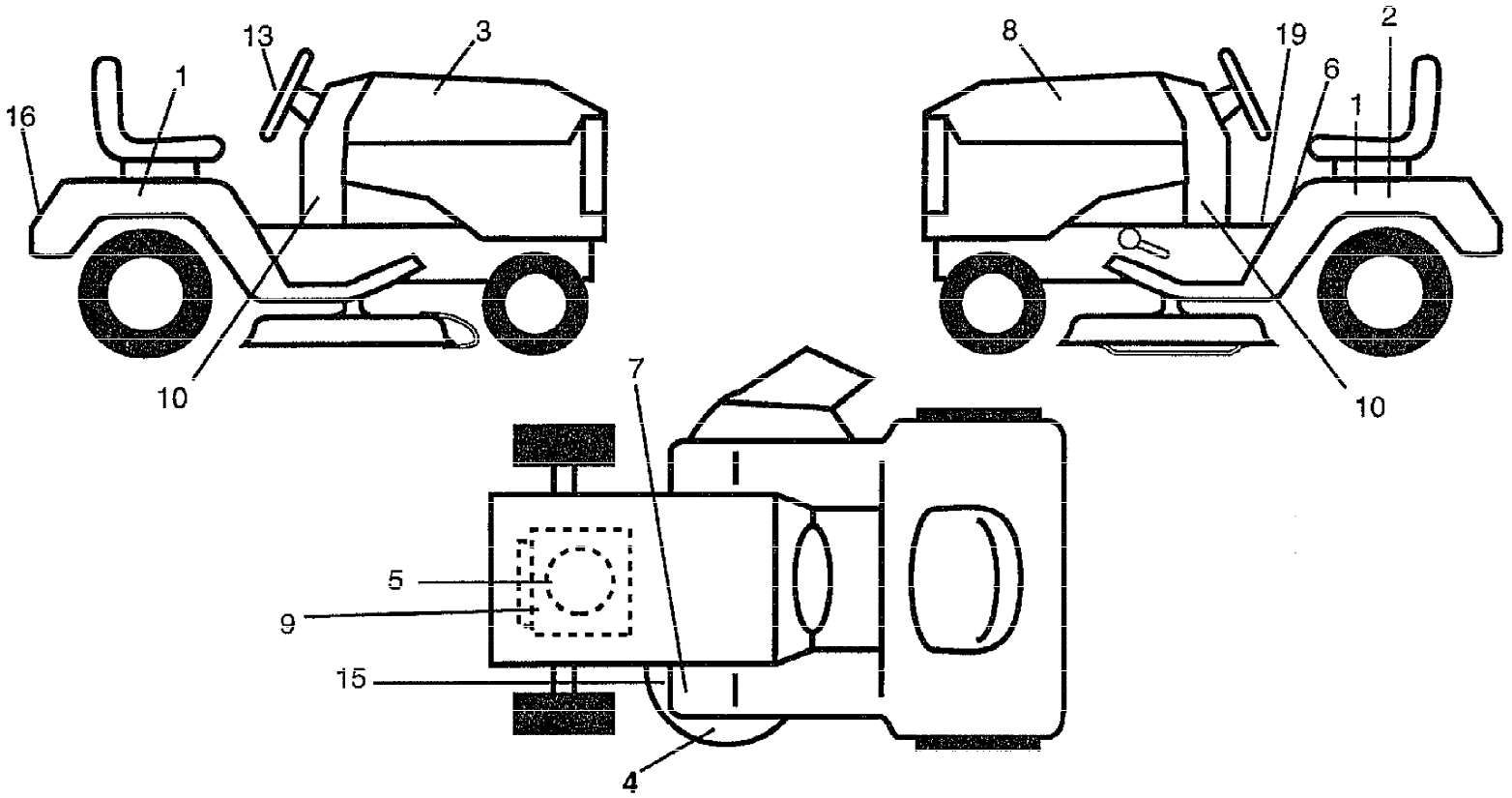

| Ref # | Part Number | Qty | Description |
|-------|-------------|-----|-----------------------|
| 1 | 166265 | | DECAL.FENDER.SD.LAWN |
| 2 | 145005 | | DECAL.BATRY.3-3908 |
| 3 | 167374 | | DECAL HOOD RH |
| 4 | 158169 | | "DECAL DECK,MULCH" |
| 5 | 165352 | | DECAL.ENGINE |
| 6 | 157140 | | DECAL.CAUT.ENG/FR |
| 7 | 101892X | | DECAL T |
| 8 | 167375 | | DECAL HOOD LH |
| 9 | 166221 | | DECAL.REPLACEMENT.ENG |
| 10 | 167376 | | DECAL DASH PNL |
| 13 | 158168 | | "DECAL WHEEL,STEER" |
| 15 | 160396 | | "DECAL-SCHEM,BELT" |
| 16 | 158166 | | "DECAL FENDER,LOGO" |
| 19 | 157163 | | "DECAL.OPER,SDL" |
| | 138311 | | DECAL HANDLE LIFT |
| | 168301 | | MANUAL, OWNER'S |
| | 168302 | | MANUAL.O.CHD14542A.E |
| | C42 | | GRASS CATCHER |
| | MK42 | | MULCH KIT W/BLADES |

| Ref # | Part Number | Qty | Description |
|-------|-------------|-----|-----------------------------|
| 1 | SUPPLIER | | CHECK WITH SUPPLIER |
| 2 | 146682 | | SPRING.BRAKE.RETU |
| 3 | 123666X | | PULLEY TRANS |
| 4 | 12000028 | | SUB= 2267J |
| 5 | 121520X | | STRAP TORQUE |
| 6 | 17490512 | | SCREW |
| 8 | 165619 | | ROD.SHIFT.FENDER.ADJ.LT.CRD |
| 10 | 76020416 | | PIN COTTER 1/8 |
| 11 | 105701X | | WASH-SHFT PLT LT |
| 13 | 74550412 | | BOLT.1/4-28.W/PAT |
| 14 | 10040400 | | LOCKWASHER |
| 18 | 74780616 | | BOLT |
| 19 | 73800600 | | NUT |
| 21 | 106933X | | KNOB T (1/2-HOLE) |
| 22 | 130804 | | BRAKE ROD |
| 24 | 73350600 | | NUT |
| 25 | 106888X | | SPRING ROD LT |
| 26 | 19131316 | | WASHER |
| 27 | 76020412 | | COTTER PIN |
| 28 | 145204 | | ROD.BRAKE.PARK.LT |
| 29 | 71673 | | PLUNGER CAP T |
| 30 | 130807 | | TRANSAXLE MTG BKT |
| 31 | 127275X | | "KEEPER,BELT LH T" |
| 32 | 74760512 | | BOLT |
| 34 | 155071 | | SHAFT ASM-PEDAL F |
| 35 | 120183X | | NYLON BEARING |
| 36 | 19211616 | | WASHER LT |
| 37 | 1572H | | SUB= 2882J |
| 38 | 131494 | | FLAT IDLER PULLEY |
| 39 | 74760644 | | BOLT |
| 40 | 4470J | | SPACER T |
| 41 | 165838 | | "KEEPER,BELT.IDLER FLAT" |
| 42 | 19131312 | | WASHER |
| 47 | 127783 | | SUB= 139245 |
| 48 | 154407 | | BELLCRANK.CLUTCH |
| 49 | 123205X | | RETAIN BELT |
| 50 | 74760624 | | SUB= 74930624 |
| 51 | 73680600 | | SUB= 73690600 |
| 52 | 73680500 | | SUB= 73690500 |
| 53 | 105710X | | "LINK, CLUTCH T" |
| 55 | 105709X | | "SPRING, RETURN LT" |
| 56 | 74760620 | | SUB= 74780620 |
| 57 | 130801 | | SUB= 138255 |
| 58 | 127274X | | "KEEPER,BELT RH T" |
| 59 | 140312 | | KEEPER BELT CNTSP |
| 61 | 17490612 | | SCREW |
| 62 | 8883R | | PEDAL COVER T |
| 63 | 140186 | | PULLEY.ENGINE |
| 64 | 71170764 | | BOLT |
| 65 | 10040700 | | LOCKWASHER |
| 66 | 154778 | | KEEPER-BELT |
| 70 | 134683 | | KEEPER BELT ENG |
| 72 | 19132012 | | WASHER |

| Ref # | Part Number | Qty | Description |
|-------|-------------|-----|----------------------------|
| 74 | 137057 | | SPACER AXLE |
| 75 | 121749X | | WASHER |
| 76 | 12000001 | | E-RING LT |
| 77 | 123583X | | SQUARE KEY |
| 78 | 121748X | | WASHER |
| 79 | 2228M | | SUB= 2228M1 |
| 80 | 131486 | | "ROD,LINK SHIFT" |
| 81 | 165594 | | SHAFT.ASM.CROSS |
| 82 | 123782X | | "SPRING,TORSION" |
| 83 | 19171216 | | WASHER |
| 84 | 166228 | | LINK.TRANSAXLE |
| 85 | 150360 | | NUT.CNT.LOCK.1/4 |
| 89 | 139964X428 | | CONSOLE.SHIFT.SLT |
| 90 | 124346X | | NUT |
| 96 | 4497H | | RETAINER M |
| 112 | 19091210 | | WASHER LT |
| 113 | 127285X | | "STRAP,TORQUE" |
| 116 | 72110610 | | BOLT RDHD 3/8-16 |
| 145 | 74490540 | | BOLT.HEX.FLGHD |
| 150 | 165850 | | BUSHING.BELLCRANK.GRD.DR |
| 151 | 19133210 | | WASHER |
| 156 | 166002 | | WASHER.SRRTD.5/16 |
| 158 | 165589 | | BRKT.SHIFT.MOUNT |
| 159 | 165494 | | HUB.SHIFT |
| 160 | 19292016 | | WASHER |
| 161 | 72140406 | | BOLT T |
| 162 | 73680400 | | SUB= 73690400 |
| 163 | 74780416 | | NLA |
| 164 | 19091010 | | WASHER.5/8X.281X10GA |
| 165 | 165623 | | BRKT.PIVOT.LEVER |
| 166 | 166880 | | SCREW.5/16-18X5/8 |
| 168 | 165492 | | BOLT.SHOULDER.5/16-18X.561 |
| 169 | 165581 | | PLATE.FASTENING |
| 171 | 17490608 | | SCREW LT |

TRACTOR - - MODEL NUMBER CHD14542A

ELECTRICAL

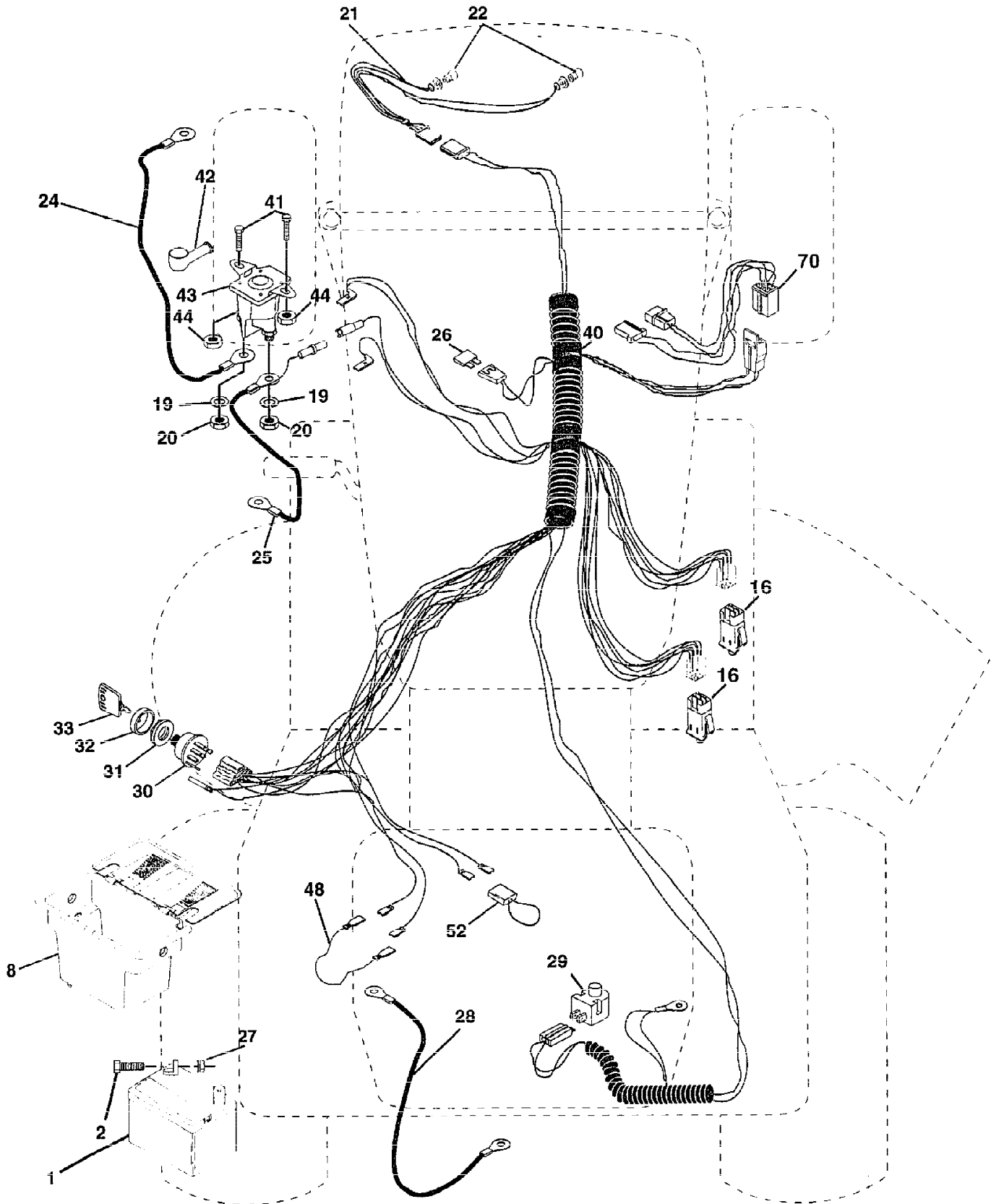

| Ref # | Part Number | Qty | Description |
|-------|-------------|-----|---------------------------|
| 1 | 144925 | | SUB= 123899X |
| 2 | 74760412 | | BOLT LT |
| 8 | 156417 | | "CASE,BATTERY.MECH" |
| 16 | 153664 | | SWITCH INTERLOCK |
| 19 | 10090400 | | SUB= 10040400 |
| 20 | 73350400 | | NUT |
| 21 | 166181 | | HARNESS.ASM.LIGHT W/4152J |
| 22 | 4152J | | HEADLAMP BULB |
| 24 | 4799J | | "CABLE T, BATTERY" |
| 25 | 146147 | | CABLE.BTRY.6GA.RD |
| 26 | 166180 | | FUSE.15 AMP |
| 27 | 73510400 | | NUT |
| 28 | 4207J | | CABLE T |
| 29 | 121305X | | SWITCH SEAT |
| 30 | 140301 | | SWITCH IGN 4POS |
| 31 | 124211X | | NUT IGNITION |
| 32 | 141226 | | COVER KEY SWITCH |
| 33 | 122147X | | KEY |
| 40 | 166145 | | HARNESS.IGNITION |
| 41 | 71110408 | | BOLT HXHD FIN |
| 42 | 131563 | | SUB= 154336 |
| 43 | 145673 | | SUB= 146154 |
| 44 | 73640400 | | NUT HXKEP 1/4X20 |
| 48 | 140844 | | ADAPTER AMMETER |
| 52 | 141940 | | PROTECTION LOOP |
| 70 | 166659 | | HARNESS.ENGINE.B&S |

TRACTOR - - MODEL NUMBER CHD14542A

ENGINE

NOTE: All component dimensions given in U.S. inches
1 inch = 25.4 mm.

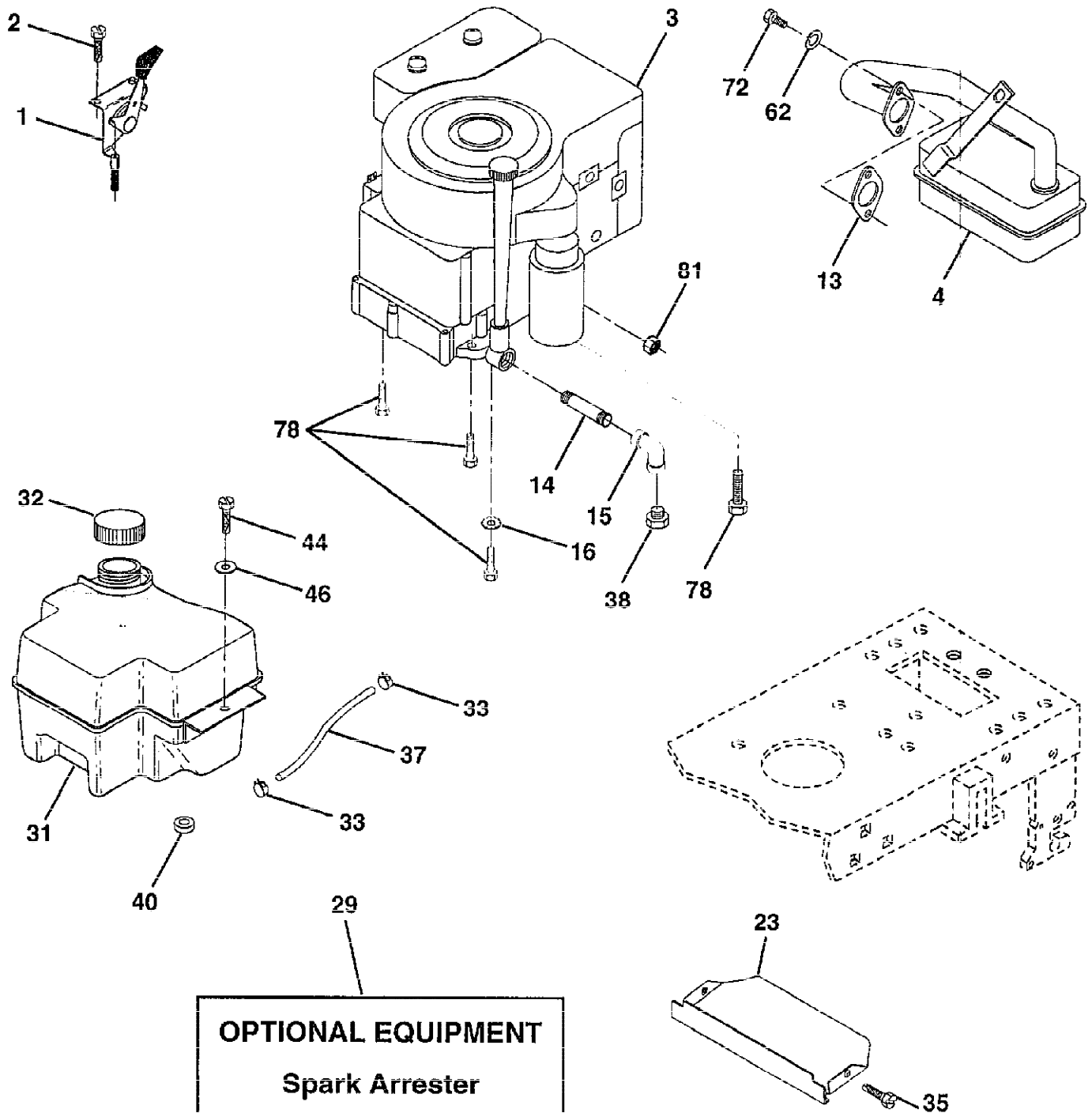

| Ref # | Part Number | Qty | Description |
|-------|-------------|-----|---------------------|
| 1 | 140310 | | CONTROL THROTTLE |
| 2 | 17720410 | | SCREW LT |
| 3 | SUPPLIER | | CHECK WITH SUPPLIER |
| 4 | 137352 | | MUFFLER |
| 13 | 165291 | | SUB= 272293 |
| 14 | 13280324 | | PIPE NIPPLE |
| 15 | 13200300 | | ELBOW |
| 16 | 11050600 | | LOCKWASHER |
| 23 | 159880 | | SHIELD.BRN/DBR.GD |
| 29 | 137180 | | SUB= 532137180 |
| 31 | 161911 | | TANK.FUEL.FRONT. |
| 32 | 140527 | | CAP ASM FUEL |
| 33 | 123487X | | HOSE CLAMP |
| 35 | 17490512 | | SCREW |
| 37 | 137040 | | LINE FUEL |
| 38 | SUPPLIER | | CHECK WITH SUPPLIER |
| 40 | 124028X | | SUB= 532124028 |
| 44 | 17490412 | | SCREW HEX CRT |
| 46 | 19091416 | | WASHER |
| 62 | 10040500 | | LOCKWASHER |
| 72 | 71070512 | | SCREW |
| 78 | 17490620 | | SCREW |
| 81 | 128861 | | NUT |

TRACTOR - - MODEL NUMBER CHD14542A

LIFT

NOTE: All component dimensions given in U.S. inches
1 inch = 25.4 mm

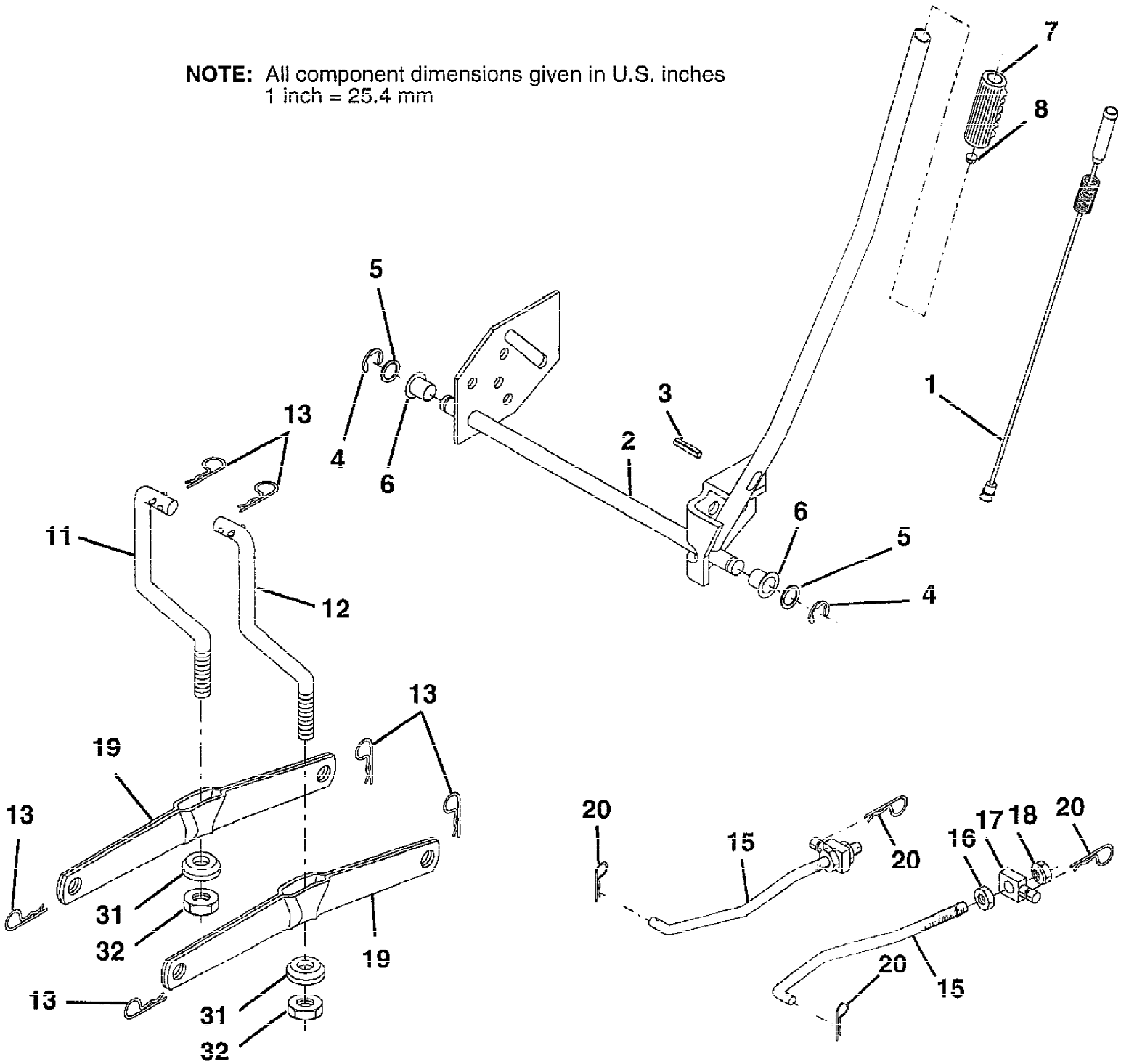

| Ref # | Part Number | Qty | Description |
|-------|-------------|-----|---------------------|
| 1 | 159460 | | WIRE ASM W.SPRING |
| 2 | 159471 | | "SHAFT ASM LIFT,RH" |
| 3 | 105767X | | PIN-GROOVE LT |
| 4 | 12000002 | | SUB= 2225J |
| 5 | 19211621 | | WASHER |
| 6 | 120183X | | NYLON BEARING |
| 7 | 109413X | | GRIP |
| 8 | 124526X | | SUB= 125925X |
| 11 | 139865 | | SUB= 918139865 |
| 12 | 139866 | | SUB= 151140 |
| 13 | 4939M | | SUB= 85902 |
| 15 | 127218 | | LINK.FRONT |
| 16 | 73350800 | | NUT |
| 17 | 130171 | | TRUNION |
| 18 | 73680800 | | NUT LTV |
| 19 | 139868 | | ARM SUSP REAR |
| 20 | 163552 | | RETAINER SPRING |
| 31 | 140302 | | BEARING PVT LH |
| 32 | 73540600 | | NUT.CROWNLOCK.3/8 |

TRACTOR -- MODEL NUMBER CHD14542A

MOWER DECK

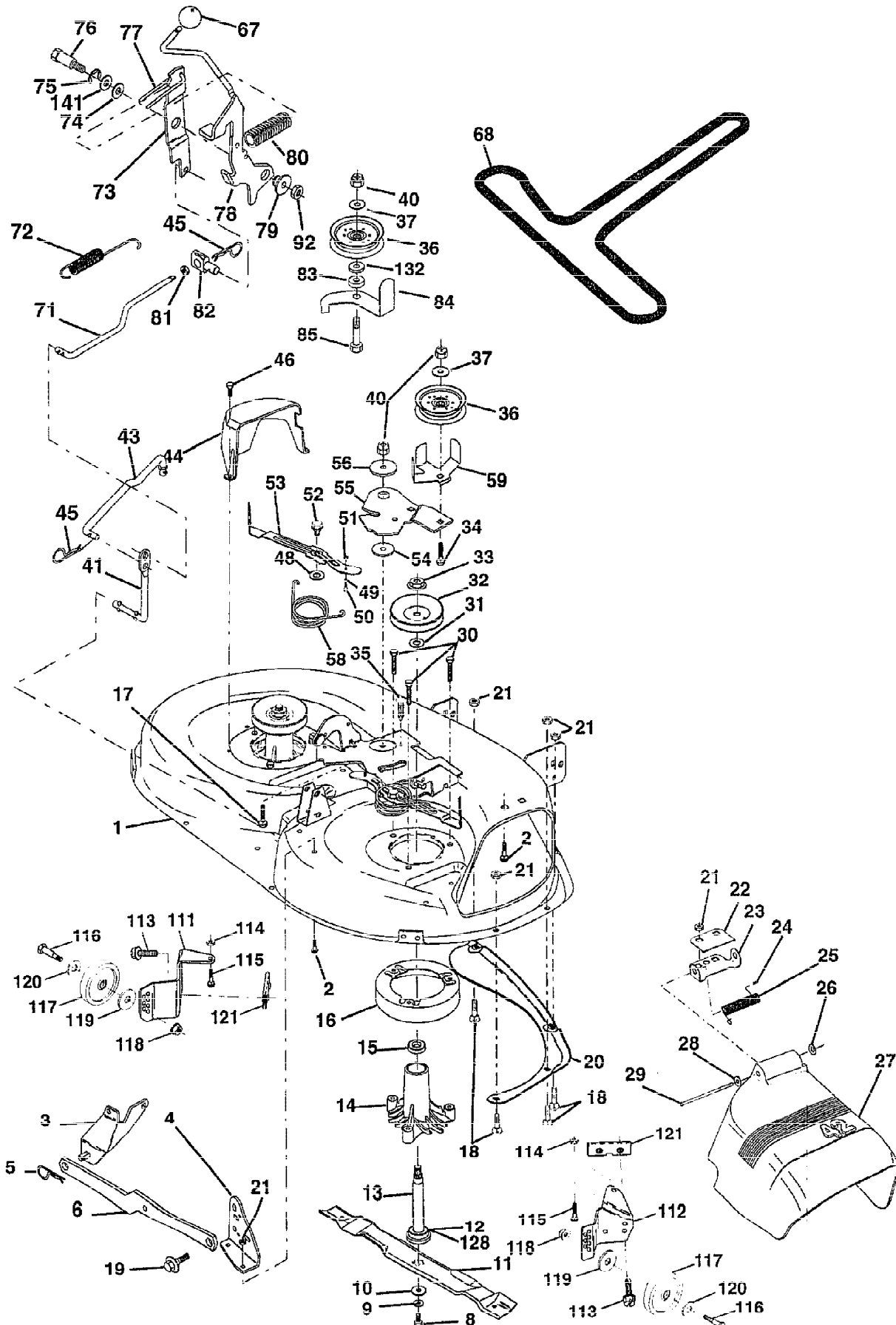

| Ref # | Part Number | Qty | Description |
|-------|-------------|-----|---------------------|
| 1 | 164961 | | "HOUSING ASSY.42"" |
| 2 | 72140506 | | BOLT |
| 3 | 138017 | | BRKT ASM SWAY BAR |
| 4 | 138440 | | BRKT DECK SW BAR |
| 5 | 4939M | | SUB= 85902 |
| 6 | 130832 | | SUB= 130833 |
| 8 | 850857 | | BLADE BOLT |
| 9 | 10030600 | | SUB= 10040600 |
| 10 | 140296 | | WASHER.HARD.BLADE |
| 11 | 138498 | | "BLADE.42"" HIPERF" |
| 12 | 129895 | | BEARING.BALL |
| 13 | 137645 | | SUB= 137646 |
| 14 | 128774 | | HSG ASM MANDREL |
| 15 | 110485X | | BEARING |
| 16 | 140329 | | STRIPPER RND MWR |
| 17 | 72110610 | | BOLT RDHD 3/8-16 |
| 18 | 72140505 | | BOLT |
| 19 | 132827 | | BOLT SHD 5/16-18 |
| 20 | 159770 | | BAFFLE VORTEX 42 |
| 21 | 73680500 | | SUB= 73690500 |
| 22 | 134753 | | STIFFENER BRKT |
| 23 | 131267 | | DEFLECTOR BRKT |
| 24 | 105304X | | CAP-SLEEVE LT |
| 25 | 123713X | | SPRING TORSION |
| 26 | 110452X | | NUT PUSH M |
| 27 | 130968 | | DEFLECTOR.SHIELD |
| 28 | 19111016 | | WASHER |
| 29 | 131491 | | HINGE ROD |
| 30 | 157722 | | "SCREW-THD ROLL,WA" |
| 31 | 129963 | | WASHER |
| 32 | 153535 | | PULLEY.MANDREL.42 |
| 33 | 137266 | | SUB= 139729 |
| 34 | 72110614 | | BOLT |
| 35 | 133835 | | XMAS TREE FASTNER |
| 36 | 131494 | | FLAT IDLER PULLEY |
| 37 | 19131316 | | WASHER |
| 40 | 73680600 | | SUB= 73690600 |
| 41 | 133551 | | PIVOT ROD |
| 43 | 140083 | | ROD CLUTCH W/NIBS |
| 44 | 140088 | | GUARD MAND LH BLK |
| 45 | 4497H | | RETAINER M |
| 46 | 137729 | | SCREW.1/4-20X5/8 |
| 48 | 133944 | | HARD SMALL WASHER |
| 49 | 155066 | | ROLLER ASM-CAM |
| 50 | 131340 | | SHOULDER BOLT |
| 51 | 69180 | | LOCKNUT |
| 52 | 139888 | | BOLT.SHLD.5/16-18 |
| 53 | 131845 | | BRAKE PAD ARM ASM |
| 54 | 133943 | | HARDENED WASHER |
| 55 | 155046 | | ARM-IDLER |
| 56 | 122052X | | SPACER RETAINER |
| 58 | 140086 | | SPRING TORSN BRAK |
| 59 | 141043 | | GUARD IDLER TUV |

| Ref # | Part Number | Qty | Description |
|-------|-------------|-----|-----------------------------|
| 67 | 162132 | | KNOB.RD.7/16-14 |
| 68 | 144200 | | BELT.V.T-PATH |
| 71 | 142427 | | ROD CLUTCH 38/42 |
| 72 | 131870 | | RETURN SPRING |
| 73 | 127847 | | CLUTCH ARM SECOND |
| 74 | 121748X | | WASHER |
| 75 | 12000029 | | RING |
| 76 | 128903 | | SHOULDER BOLT |
| 77 | 127845 | | SPRING KEEPER |
| 78 | 160570 | | LEVER.ASM.CLUTCH |
| 79 | 127498 | | BUSHING |
| 80 | 153701 | | SPRING.CLUTCH.MWR |
| 81 | 73350600 | | NUT |
| 82 | 142028 | | TRUNION ADJ |
| 83 | 120958X | | WASHER |
| 84 | 156084 | | "KEEPER-BELT,FIXED" |
| 85 | 72140620 | | BOLT |
| 92 | 73800600 | | NUT |
| 111 | 155197 | | BRACKET.GWHL.LH. |
| 112 | 155198 | | BRACKET.GWHL.RH. |
| 113 | 17490512 | | SCREW |
| 114 | 73510500 | | NUT |
| 115 | 72110504 | | SUB= 872110504 |
| 116 | 4898H | | BOLT M |
| 117 | 105455X | | WHEEL.GAGE.BLK.PL |
| 118 | 73930600 | | LOCKNUT |
| 119 | 19121414 | | WASHER |
| 120 | 19171512 | | WASHER |
| 121 | 143723 | | BRACKET.EXTRD.GWL |
| 128 | 153390 | | WASHER.FELT. |
| 132 | 19132203 | | WASHER GT |
| 141 | 6266H | | WASHER .T |
| | 130794 | | MANDREL ASM |
| | 164962 | | "DECK.MOWER SERV.42"" MECH" |

TRACTOR - MODEL NUMBER CHD14542A

SCHEMATIC

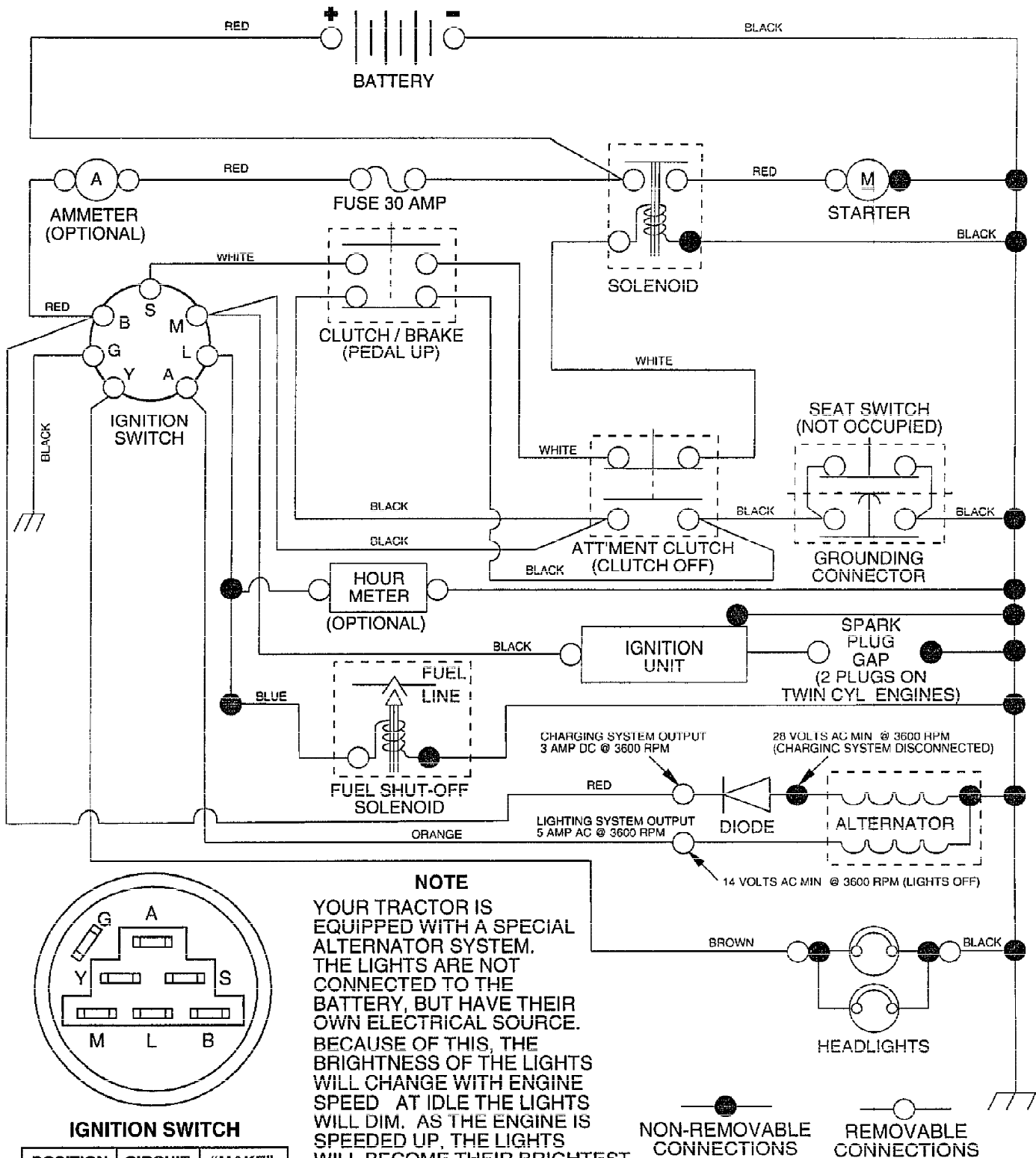

| Ref # | Part Number | Qty | Description |
|-------|-------------|-----|----------------|
| | REFER | | REFER TO IMAGE |

TRACTOR - - MODEL NUMBER CHD14542A

SEAT ASSEMBLY

NOTE: All component dimensions given in U.S. inches
1 inch = 25.4 mm.

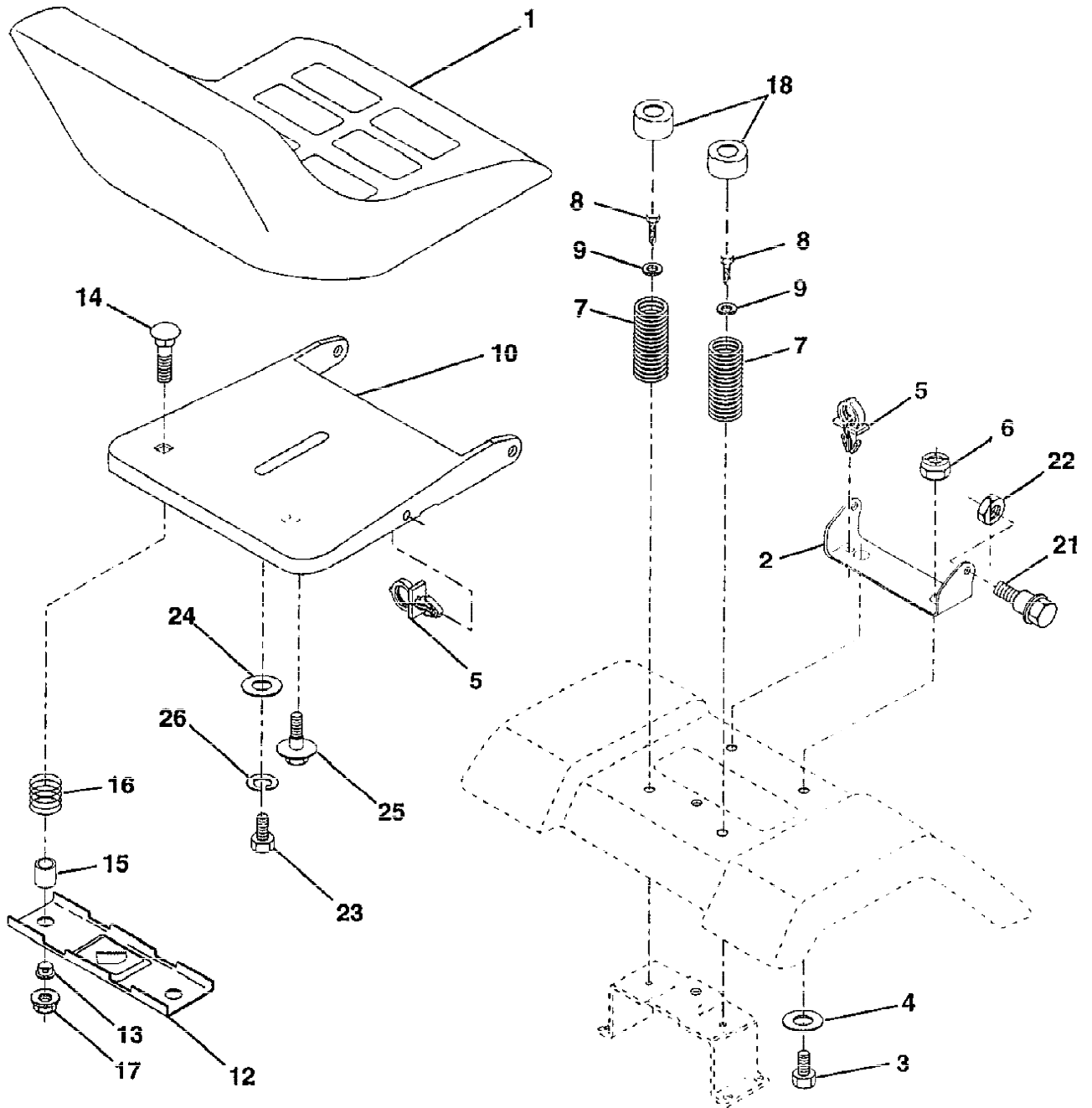

| Ref # | Part Number | Qty | Description |
|-------|-------------|-----|-------------------|
| 1 | 140116 | | SEAT |
| 2 | 140551 | | BRACKET PVT SEAT |
| 3 | 74760616 | | BOLT |
| 4 | 19131610 | | WASHER PM |
| 5 | 145006 | | CLIP.PUSH-IN.HING |
| 6 | 73800600 | | NUT |
| 7 | 124181X | | SPRING COMPRESSIO |
| 8 | 17490616 | | SCREW GTV |
| 9 | 19131614 | | WASHER |
| 10 | 155925 | | PAN-SEAT |
| 12 | 121246X | | BRKT SWITCH |
| 13 | 121248X | | BUSHING |
| 14 | 72050412 | | BOLT-RD HD SQ NK |
| 15 | 134300 | | SPLIT SPACER |
| 16 | 121250X | | SPRING |
| 17 | 123976X | | SUB= 73900400 |
| 18 | 124238X | | CAP SPRING |
| 21 | 153236 | | "BOLT,SHOULDER" |
| 22 | 73800500 | | NUT |
| 23 | 74780814 | | BOLT |
| 24 | 19171912 | | WASHER |
| 25 | 127018X | | "BOLT,SHOULDER" |
| 26 | 10040800 | | LOCKWASHER |

| Ref # | Part Number | Qty | Description |
|-------|-------------|-----|------------------------|
| 1 | 140044 | | WHEEL STR AYP BLK |
| 2 | 154427 | | AXLE ASM |
| 3 | 156483 | | SPINDLE.ASM.LH |
| 4 | 157473 | | "SPINDLE ASM,RH" |
| 5 | 6266H | | WASHER .T |
| 6 | 121748X | | WASHER |
| 7 | 19272016 | | WASHER |
| 8 | 12000029 | | RING |
| 9 | 3366R | | COL. SRTG. BEAR. |
| 10 | 156438 | | DRAGLINK-STAMPED |
| 11 | 10040600 | | LOCKWASHER |
| 13 | 154779 | | BEARING AXLE |
| 15 | 73901000 | | "NUT-LOC,FLANGE LT" |
| 17 | 156546 | | SHAFT ASM STEERIN |
| 18 | 57079 | | THRUST WASHER |
| 19 | 160395 | | SUPPORT.SHAFT.STEER |
| 22 | 165857 | | SCREW.HX.WSH.HD |
| 23 | 165851 | | SHAFT.ASM.PITMAN |
| 25 | 154406 | | BRKT-STEERING |
| 26 | 126847X | | BUSHING.DRAGLINK |
| 27 | 136874 | | GEAR SECTOR |
| 28 | 19131416 | | WASHER |
| 29 | 17490612 | | SCREW |
| 30 | 76020412 | | COTTER PIN |
| 32 | 130465 | | TIE ROD |
| 36 | 155099 | | BUSHING.STEERING |
| 37 | 152927 | | "SCREW-TT,10-32 FL" |
| 38 | 140045 | | CAP STEER AYP |
| 39 | 19133808 | | WASHER T |
| 40 | 7810H | | GRIPCO NUT |
| 41 | 100711L | | ADAPTER LT |
| 42 | 145054 | | BOOT.STEER.PL |
| 43 | 121749X | | WASHER |
| 44 | 153720 | | EXT SHAFT STEERIN |
| 46 | 121232X | | CAP |
| 47 | 6855M | | ZERK M |
| 51 | 73800500 | | NUT |
| 54 | 74780520 | | BOLT |
| 62 | 156594 | | KIT STEERING ASM |
| 63 | 74780616 | | BOLT |
| 65 | 154780 | | SPACER AXLE |
| 66 | 154404 | | "BEARING-ARM,PITMA" |
| 67 | 74781044 | | BOLT |
| 68 | 154429 | | BRACE AXLE |
| 79 | 19132012 | | WASHER |
| 80 | 74950612 | | BOLT.HX.NYLON3/8-16X3/ |

TRACTOR - - MODEL NUMBER CHD14542A

WHEELS & TIRES

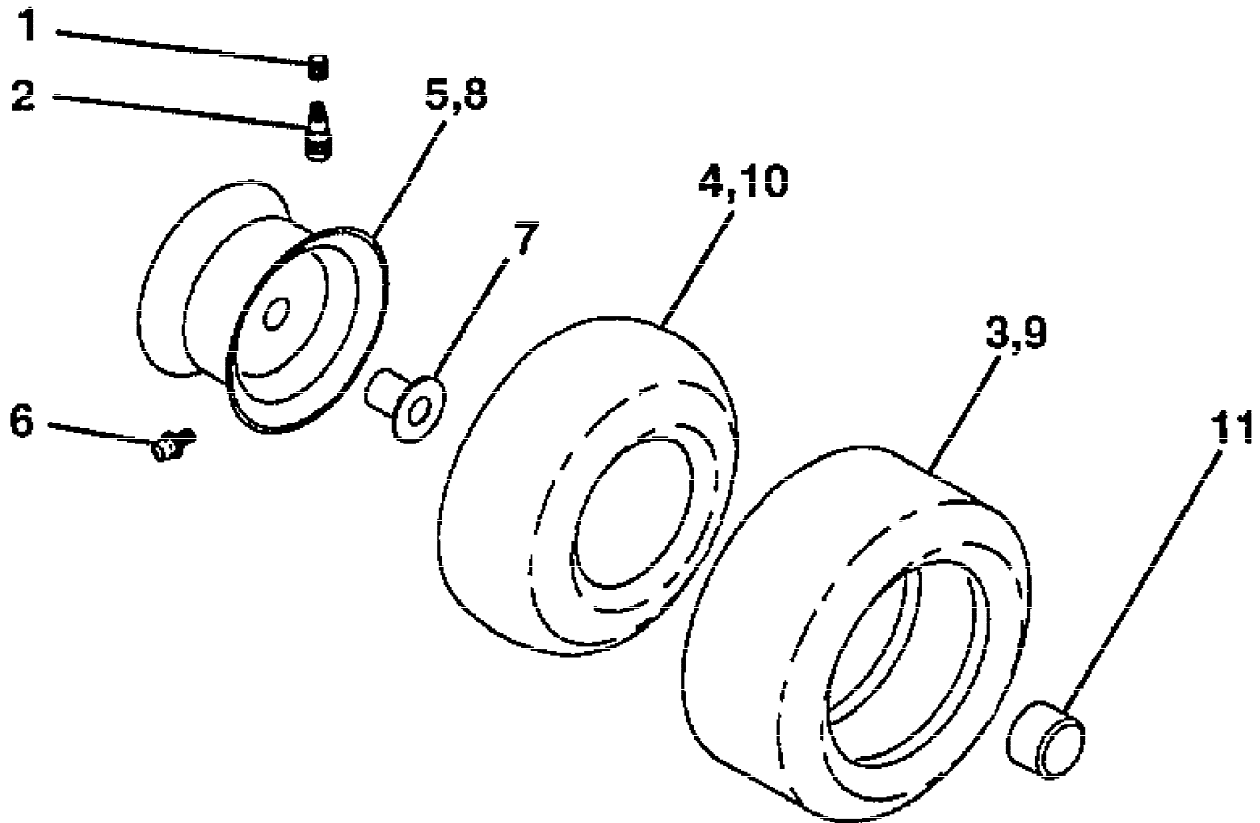

NOTE: All component dimensions given in U.S. inches
1 inch = 25.4 mm.

| Ref # | Part Number | Qty | Description |
|-------|-------------|-----|--------------------------|
| 1 | 59192 | | VALVE CAP |
| 2 | 65139 | | VALVE STEM LT |
| 3 | 106222X | | SUB= 122073X |
| 4 | PARTSIMAGE | | REFER TO PARTS IMAGE |
| 4 | 59904 | | TUBE.5.3/4.5/6 |
| 5 | 106732X427 | | "RIM ASM 6"" FRT" |
| 6 | 278H | | FITTING LT |
| 7 | 9040H | | "FLANGE, BEARING" |
| 8 | 106108X427 | | "RIM AS 8"" REAR" |
| 9 | 106268X | | SUB= 122074X |
| 10 | PARTSIMAGE | | REFER TO PARTS IMAGE |
| 10 | 7152J | | TUBE.18X9.5-8 |
| 11 | 104757X | | HUB CAP |
| | 144334 | | SEALANT.TIRE 10 OZ. TUBE |