

TRACTOR - MODEL NUMBER  
CHASSIS AND ENCLOSURES

(PP16H46B), PRODUCT NO. 954 19 00-12

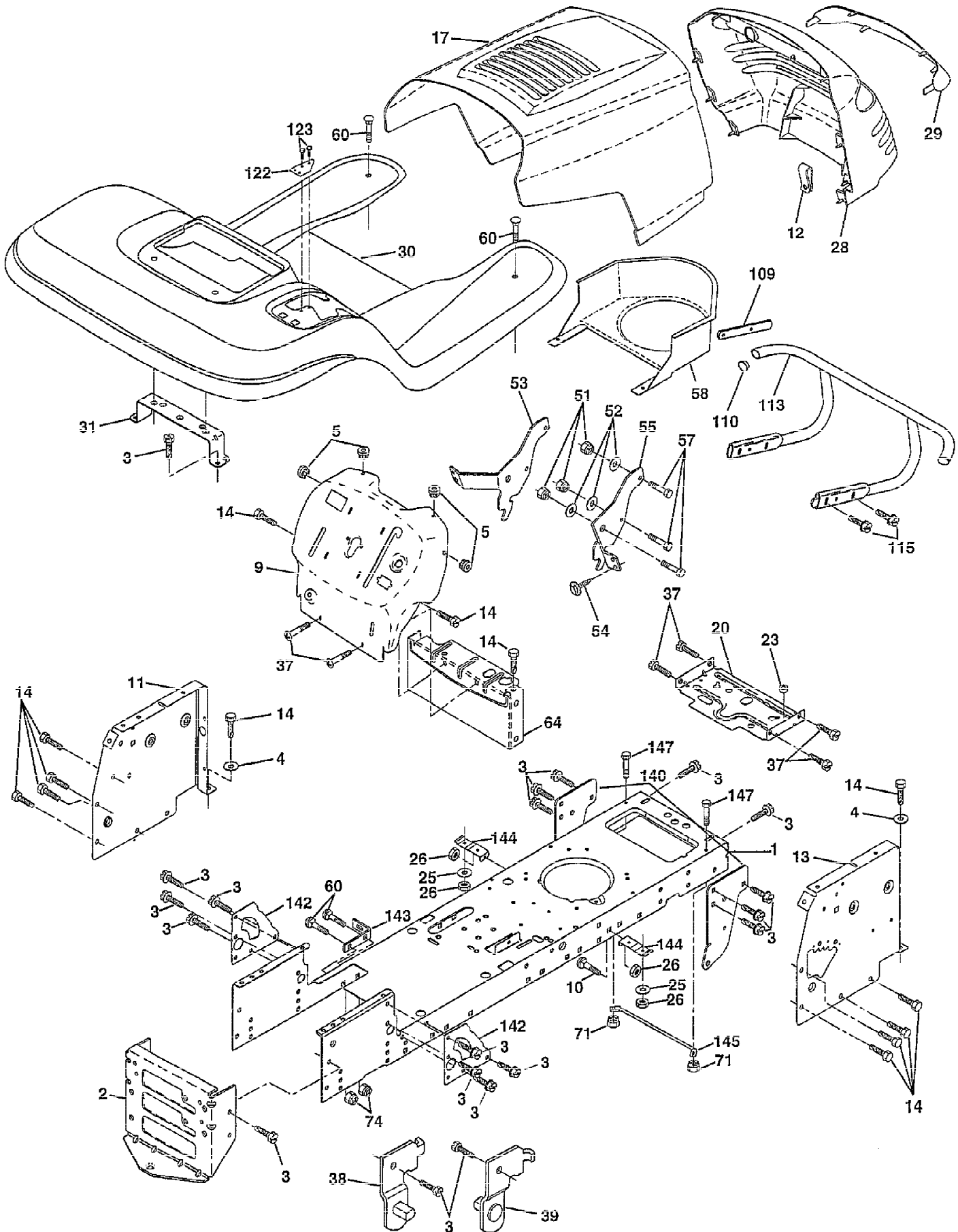

Ref #	Part Number	Qty	Description
1	159527		CHASSIS
3	140356		SUB= 145009
3	17490612		SCREW
4	19131216		WASHER
5	155272		BUMPER-HOOD/DASH
9	154793X010		DASH SLKSCR
10	72140608		SUB= 72110608
11	155927		"PANEL-DASH,LH"
12	145660		CLIP.TINNERMAN
13	155936		"PANEL-DASH,RH"
14	17490608		SCREW LT
17	139394X428		SUB= 159639X428
20	156437		"PLATE-MTG,BATT/FU"
23	124028X		SUB= 532124028
25	19131312		WASHER
26	73800600		NUT
28	157373		GRILLE-MS428
29	140273		LENS GRILLE
30	151287X505		FENDER/FOOTREST
31	139976		BRACKET SUPT FEND
37	17490508		SCREW LT
38	139886		BRACKET ASM LH
39	139887		BRACKET ASM RH
51	73800400		NUT
52	19091416		WASHER
53	144697		BRACKET.GRILLE.LH
54	17030814		SUB= 91817030814
55	144696		BRACKET.GRILLE.RH
57	74780412		SUB= 74780414
58	150127		AIR DUCT
60	72140606		BOLT
64	154798		DASH-LOWER
71	73680400		SUB= 73690400
74	73680600		SUB= 73690600
109	141461		BRACKET.EXT.BUMP.
110	143679		PLUG.PLASTIC
113	150300		BUMPER.ASM
115	17490620		SCREW
122	157301		"BRKT SHIFT,LT"
123	152927		"SCREW-TT,10-32 FL"
140	158418		BRKT SUSPENSION
142	156095		PLATE.REINFORCMT
143	154966		"BRKT-S'BAR,CHASSI"
144	154207		BRKT-FOOTREST
145	156524		"ROD POVOT,CHASSIS"
147	74760412		BOLT LT
	5479J		PLUG BUTTON T

**TRACTOR - MODEL NUMBER (PP16H46B), PRODUCT NO. 954 19 00-12**  
**DECALS**

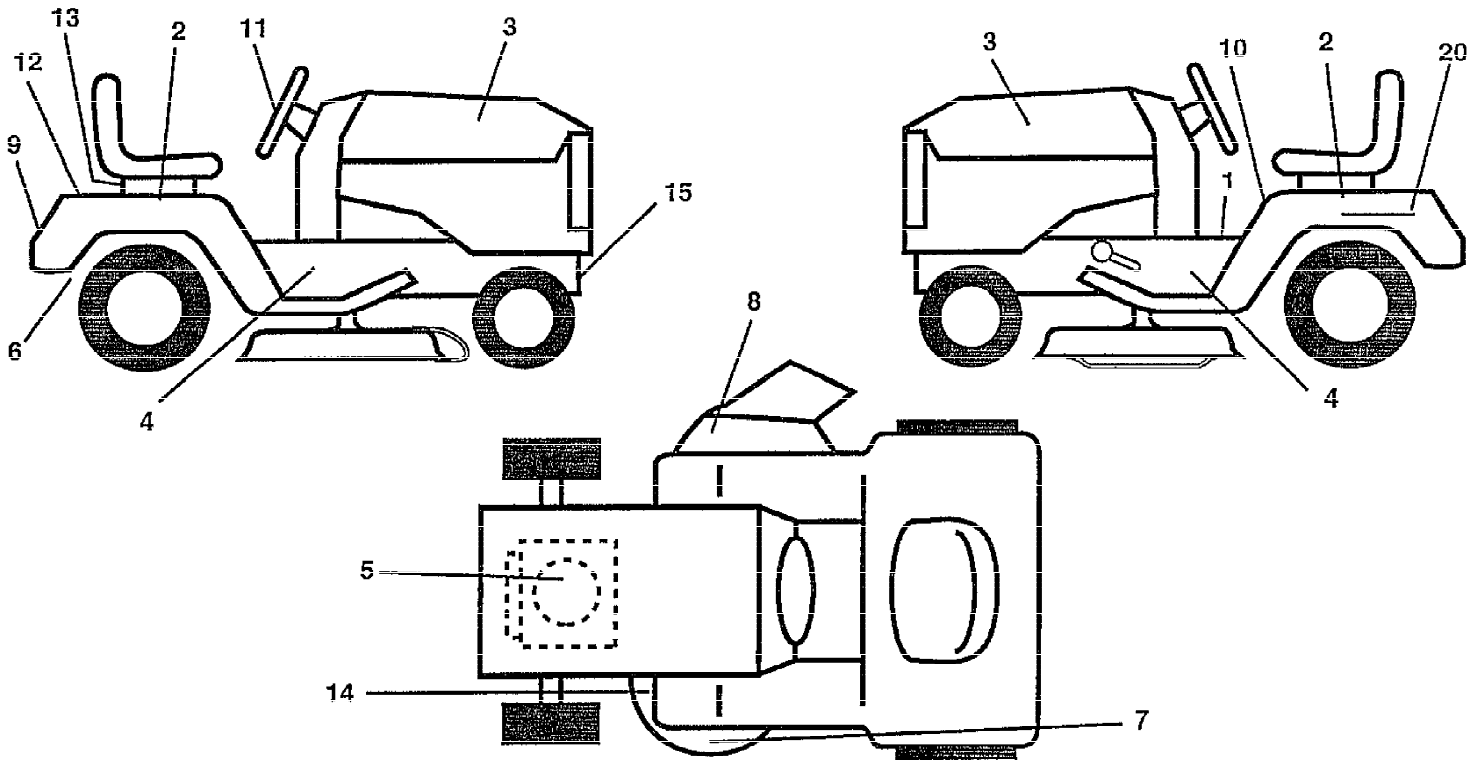

Ref #	Part Number	Qty	Description
1	157032		"DECAL FENDER,OPER"
2	158051		DECAL FENDER AUTO
3	158049		DECAL HOOD PREDAT
4	158052		"DECAL CHASSIS 46""
5	273210		DECAL, ENGINE B&S
6	142341		DECAL DRAWBAR LH
7	134999		"DECAL,ENVIRO DECK"
8	137259		"DECAL, WARNING"
9	158361		DECAL FENDER DOME
10	157140		DECAL.CAUT.ENG/FR
11	158048		DECAL INS STRG WH
12	158050		DECAL FENDER PRED
13	150496		RETAINER-SPRING
14	139346		"DECAL.V.BELT.44""
15	158058		DECAL CHASSIS PRE
20	145005		DECAL.BATRY.3-3908
	154515		"PAD-FOOTREST,LH"
	154516		"PAD-FOOTREST, RH"
	138311		DECAL HANDLE LIFT
	159852		MANUAL.O.PP16H46B
	159853		MANUAL.O.PP16H46B
	LSB42		SNOW THROWER
	LCO5		WHEEL WEIGHTS
	LCO6		TIRE CHAINS

TRACTOR - MODEL NUMBER

(PP16H46B), PRODUCT NO. 954 19 00-12

DRIVE

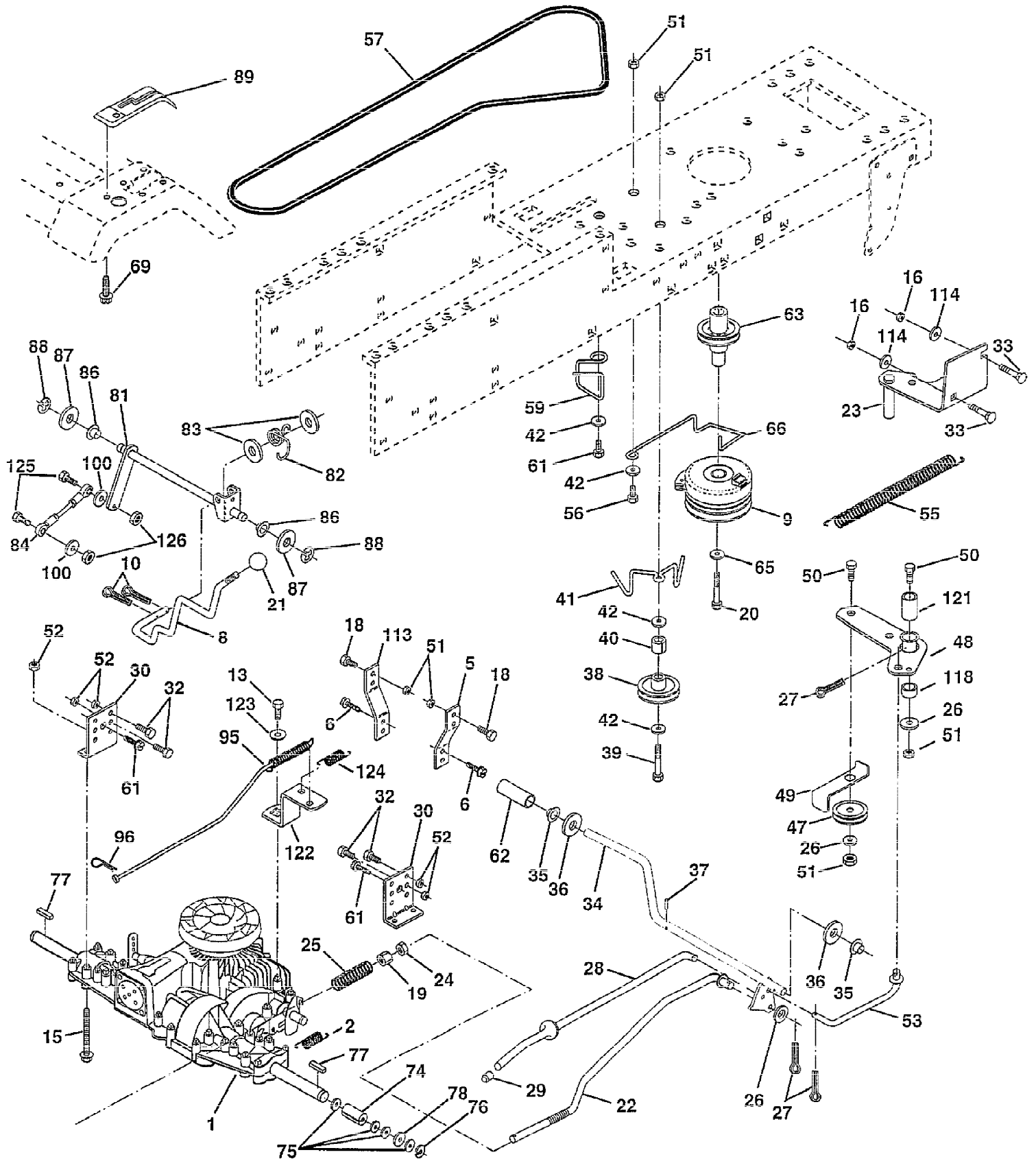

Ref #	Part Number	Qty	Description
1	PARTSIMAGE		REFER TO PARTS IMAGE
1	SUPPLIER		CHECK WITH SUPPLIER
2	146682		SPRING.BRAKE.RETU
3	143995		PULLEY.TRANSAXLE
5	121520X		STRAP TORQUE
6	17490512		SCREW
8	154792		"ROD SHIFT,FENDER"
9	145028		CLUTCH.ELECT.EVX.
10	76020416		PIN COTTER 1/8
13	74550412		BOLT.1/4-28.W/PAT
15	74490544		BOLT.HX.FLG.5/16
16	73800500		NUT
18	74780616		BOLT
19	73800600		NUT
20	150280		BOLT.7/16-20X4.25
21	121274X		KNOB.DUCKHEAD.1/2
22	130804		BRAKE ROD
23	154978		BRACKET.CLUT.MTG.
24	73350600		NUT
25	106888X		SPRING ROD LT
26	19131316		WASHER
27	76020412		COTTER PIN
28	145204		ROD.BRAKE.PARK.LT
29	71673		PLUNGER CAP T
30	130807		TRANSAXLE MTG BKT
32	74760512		BOLT
33	72140506		BOLT
34	155071		SHAFT ASM-PEDAL F
35	120183X		NYLON BEARING
36	19211616		WASHER LT
37	1572H		SUB= 2882J
38	123674X		PULLEY.IDLER.FLAT
39	74760644		BOLT
40	4470J		SPACER T
41	154777		SUB= 165692
42	19131312		WASHER
47	127783		SUB= 139245
48	154604		BELLCRANK ASM
49	123205X		RETAIN BELT
50	74760624		SUB= 74930624
51	73680600		SUB= 73690600
52	73680500		SUB= 73690500
53	105710X		"LINK, CLUTCH T"
55	105709X		"SPRING, RETURN LT"
56	74760620		SUB= 74780620
57	156971		"V-BELT,GRD DRIVE"
59	140312		KEEPER BELT CNTSP
61	17490612		SCREW
62	8883R		PEDAL COVER T
63	145868		PULLEY.CLUTCH.EVX
65	10040700		LOCKWASHER
66	154778		KEEPER-BELT
74	156972		"SPACER AXLE,PVST"

Ref #	Part Number	Qty	Description
75	121749X		WASHER
76	12000001		E-RING LT
77	123583X		SQUARE KEY
78	121748X		WASHER
81	156969		SHAFT ASM CROSS
82	123782X		"SPRING,TORSION"
83	19171216		WASHER
84	156962		"ROD TIE, PVST 20""
86	71208		BUSHING
87	19212016		WASHER D
88	12000008		KLIP RING
89	154882		SUB= 158388
90	124346X		NUT
95	156970		ROAD ASM BYPASS
96	4497H		RETAINER M
100	19111216		WASHER M
113	127285X		"STRAP,TORQUE"
114	19111214		WASHER
118	154774		SPACER-BELLCRANK
121	154419		NYLINER-CLUTCHING
122	156963		"PLATE-BYPASS,PVST"
123	19091016		WASHER
125	74780516		SUB= 77394
126	1685H		SUB= 68478

TRACTOR - MODEL NUMBER  
ELECTRICAL

(PP16H46B), PRODUCT NO. 954 19 00-12

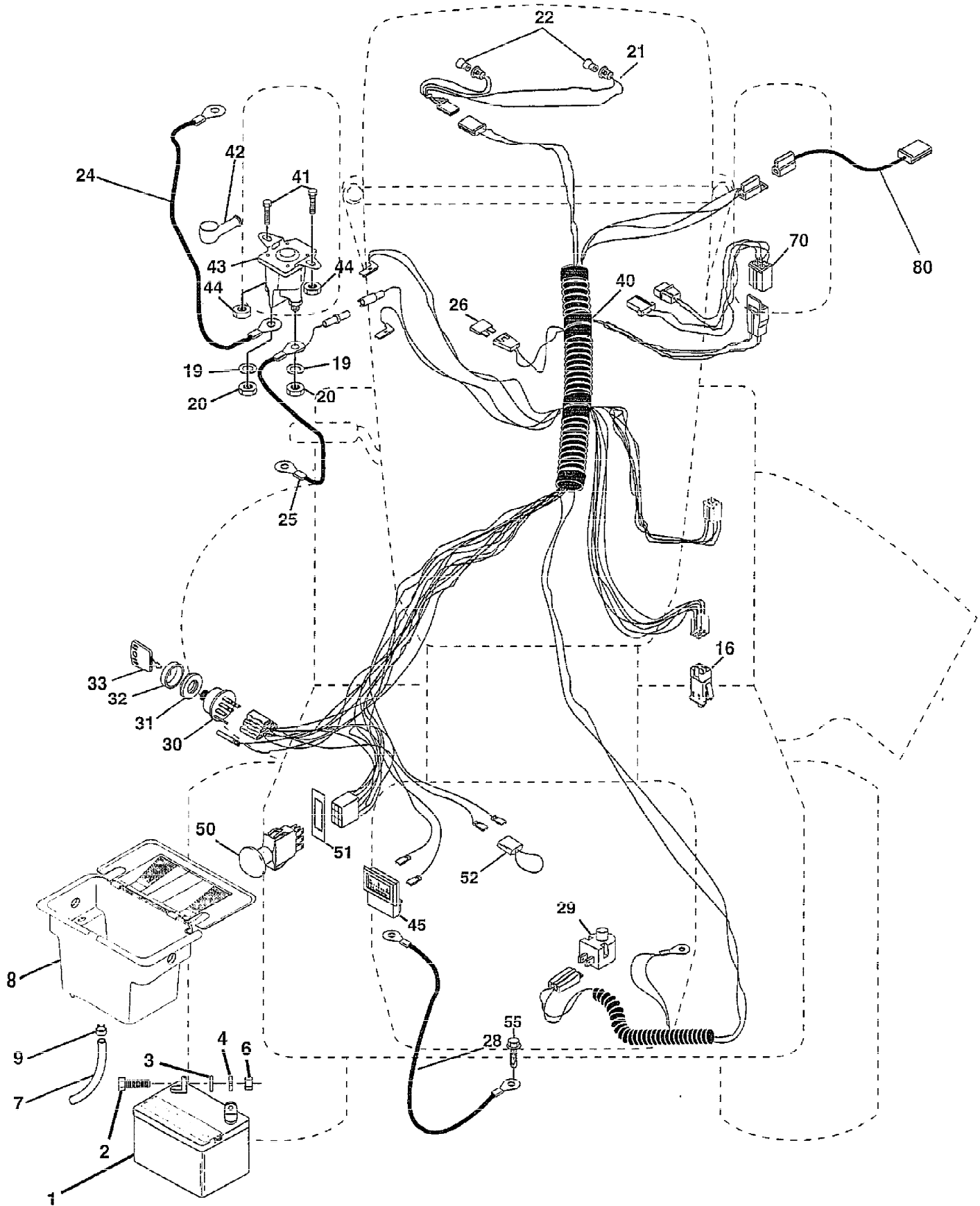



Ref #	Part Number	Qty	Description
1	144926		SUB= 123899X
2	74760412		BOLT LT
3	19091016		WASHER
4	10040400		LOCKWASHER
6	73220400		SUB= 50675
7	109238X		TUBE T
8	156417		"CASE,BATTERY.MECH"
9	109596X		HOSE CLAMP T
16	153664		SWITCH INTERLOCK
19	10090400		SUB= 10040400
20	73350400		NUT
21	136850		"HARNES, LIGHT SOC"
22	4152J		HEADLAMP BULB
24	4799J		"CABLE T, BATTERY"
25	146147		CABLE.BTRY.6GA.RD
26	108824X		FUSE HYT
28	4207J		CABLE T
29	121305X		SWITCH SEAT
30	140301		SWITCH IGN 4POS
31	124211X		NUT IGNITION
32	141226		COVER KEY SWITCH
33	122147X		KEY
40	158684		HARNES IGNITION
41	71110408		BOLT HXHD FIN
42	131563		SUB= 154336
43	145673		SUB= 146154
44	73640400		NUT HXKEP 1/4X20
45	121433X		SUB= 122822X
50	154959		PTO SWITCH.BLK
51	140405		RING RETAIN PTO
52	141940		PROTECTION LOOP
70	140422		HARNES.ENG.DUAL
80	146685		HARNES.CLUT.EVX.

TRACTOR - MODEL NO.

(PP16H46B), PRODUCT NO. 954 19 00-12

ENGINE

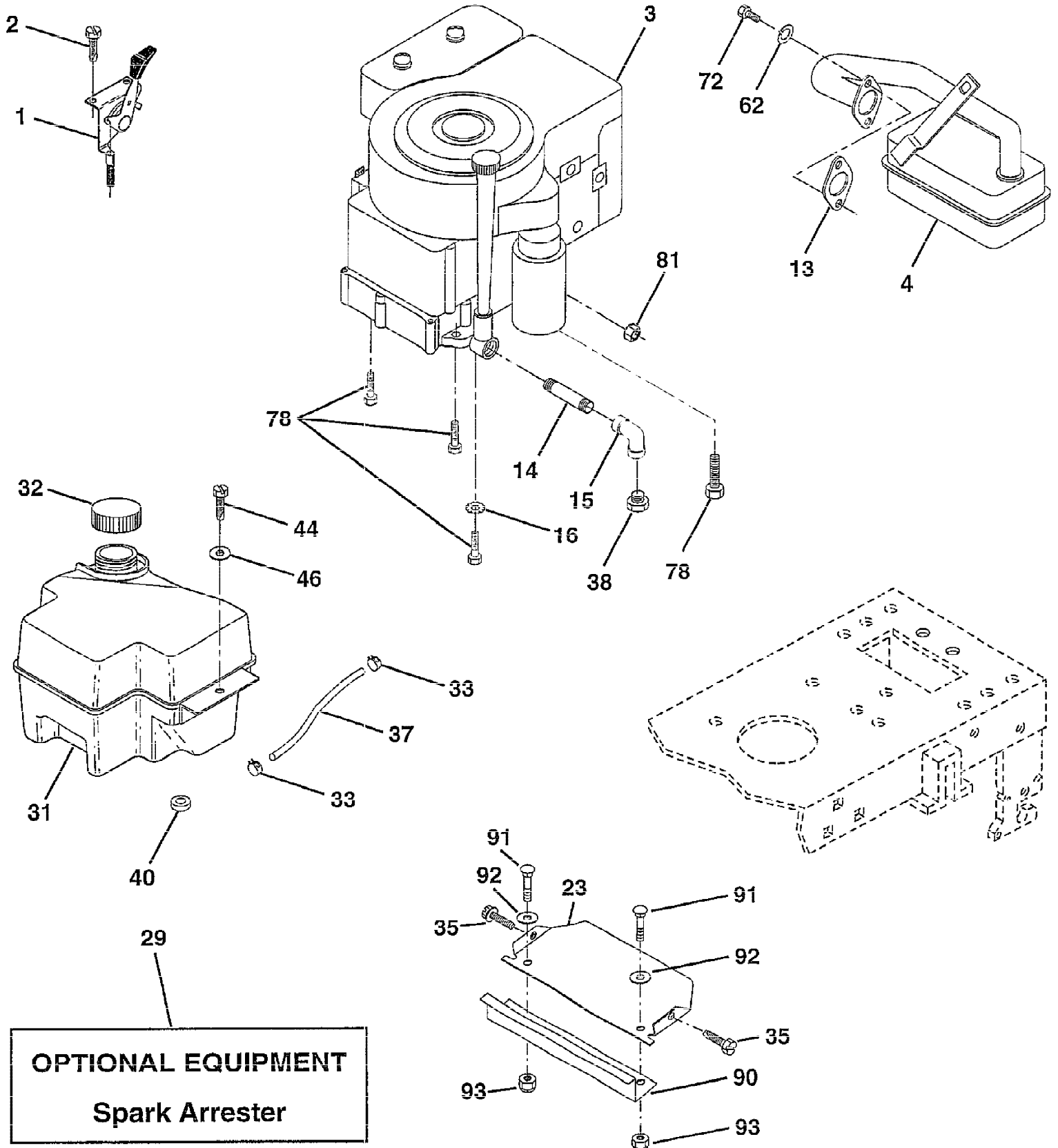

Ref #	Part Number	Qty	Description
1	140310		CONTROL THROTTLE
2	17720410		SCREW LT
3	SUPPLIER		CHECK WITH SUPPLIER
4	137352		MUFFLER
13	272293		GASKET ENG 1 313 LD TIN PLATED
14	13280324		PIPE NIPPLE
15	13200300		ELBOW
16	11050600		LOCKWASHER
23	156123		SHIELD-HEAT
29	137180		SUB= 532137180
31	140280		SUB= 161911
32	140527		CAP ASM FUEL
33	123487X		HOSE CLAMP
35	17490512		SCREW
37	137040		LINE FUEL
38	SUPPLIER		CHECK WITH SUPPLIER
40	124028X		SUB= 532124028
44	17490412		SCREW HEX CRT
46	19091416		WASHER
49	17490616		SCREW GTV
62	10040500		LOCKWASHER
72	71070512		SCREW
78	17490620		SCREW
81	128861		NUT
90	159520		GUARD-DEBRIS
91	7110408		BOLT BLK FIN HEX 1/4-20 UNCX 1/2
92	19091016		WASHER
93	123976X		SUB= 73900400

TRACTOR - MODEL NO.  
MOWER DECK

(PP16H46B), PRODUCT NO. 954 19 00-12

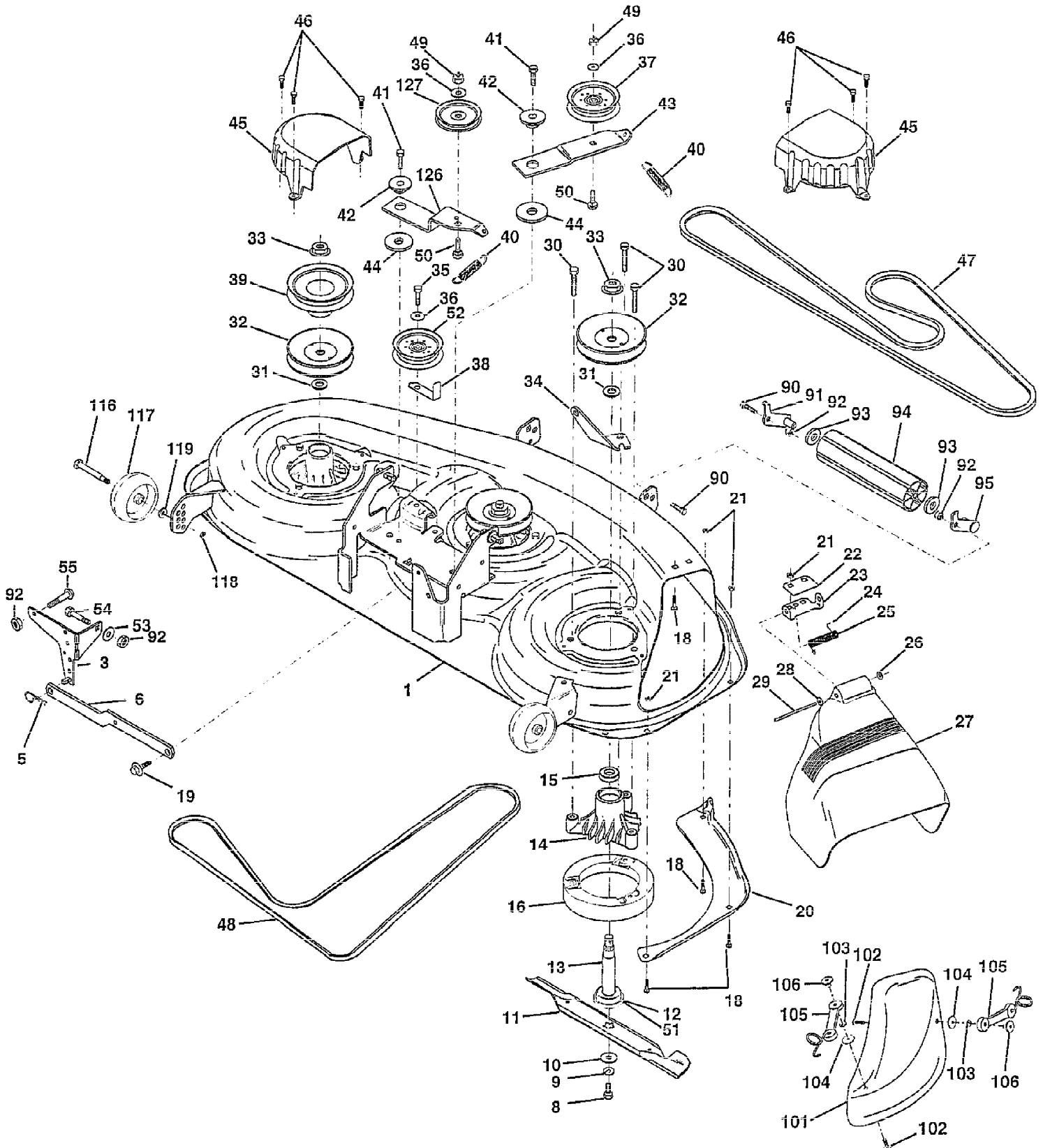

Ref #	Part Number	Qty	Description
1	156948		"MOWER ASM 46""
3	138457		BRKT.ASM.SW.44/50
5	4939M		SUB= 85902
6	130832		SUB= 130833
8	850857		BLADE BOLT
9	10030600		SUB= 10040600
10	140296		WASHER.HARD.BLADE
11	152443		SUB= 918152443
12	129895		BEARING.BALL
13	137553		SHAFT.ASM.W/BRNG
14	137152		HOUSING.MAND.44.V
15	110485X		BEARING
16	140329		STRIPPER RND MWR
18	72140505		BOLT
19	132827		BOLT SHD 5/16-18
20	145055		BAFFLE.VORTEX.46
21	73680500		SUB= 73690500
22	134753		STIFFENER BRKT
23	131267		DEFLECTOR BRKT
24	105304X		CAP-SLEEVE LT
25	123713X		SPRING TORSION
26	110452X		NUT PUSH M
27	157788		SHIELD DEFLECTOR
28	19111016		WASHER
29	131491		HINGE ROD
30	138776		SUB= 157722
31	129963		WASHER
32	153531		PULLEY.MAND.36/46
33	137266		SUB= 139729
34	144945		ANCHOR.SPRING.46
35	17490628		SCREW LT
36	19131316		WASHER
37	131494		FLAT IDLER PULLEY
38	156086		"KEEPER BELT, IDLER"
39	144917		PULLEY.DRV.DCK.46
40	137273		"SPRING.SEC.44""VEN"
41	17490620		SCREW
42	122052X		SPACER RETAINER
43	144949		ARM.IDLER.DECK.46
44	133943		HARDENED WASHER
45	145059		COVER.MANDREL.46
46	137729		SCREW.1/4-20X5/8
47	144959		BELT-V.SEC.46.KEL
48	139573		BELT V PRIM 50
49	73680600		SUB= 73690600
50	72110612		BOLT.3/8-16X1.50
51	153390		WASHER.FELT.
52	156493		"PULLEY IDLER,FLAT"
53	19131312		WASHER
54	74780616		BOLT
55	72140608		SUB= 72110608
90	74760616		BOLT
91	132274		SUB= 532132274

Ref #	Part Number	Qty	Description
92	73800600		NUT
93	19171416		WASHER
94	132264		SUB= 532132264
95	132273		SUB= 532132273
101	145579		COVER.MULCHING.
102	71161010		SCREW
103	10071000		LOCKWASHER
104	19061216		WASHER #10
105	130758		SUB= 160793
106	2029J		WELDNUT
116	146851		BOLT.SHOULDER
117	146850		WHEEL.GUAGE.MED.
118	73930600		LOCKNUT
119	19121414		WASHER
126	144948		ARM.IDLER.PRIM.46
127	146763		PULLEY.IDLER.4.25
	143651		MANDREL SERV ASM
	158851		"MOWER SERVICE 46""

TRACTOR - MODEL NO.  
MOWER LIFT

(PP16H46B), PRODUCT NO. 954 19 00-12

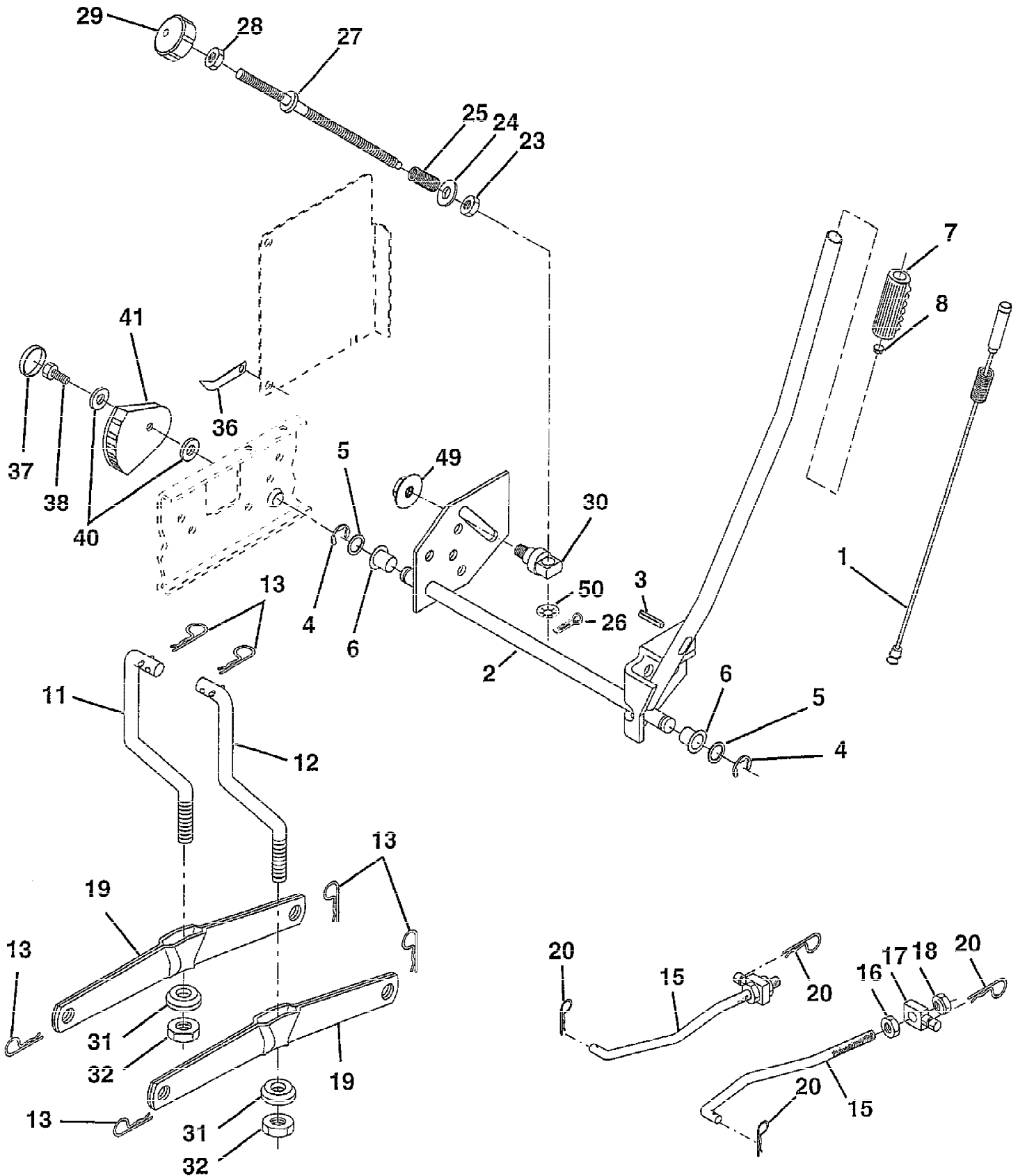

Ref #	Part Number	Qty	Description
1	159460		WIRE ASM W.SPRING
2	159471		"SHAFT ASM LIFT,RH"
3	105767X		PIN-GROOVE LT
4	12000002		SUB= 2225J
5	19211621		WASHER
6	120183X		NYLON BEARING
7	109413X		GRIP
8	124526X		SUB= 125925X
10	122512X		SUB= 532122512
11	139865		SUB= 918139865
12	139866		SUB= 151140
13	4939M		SUB= 85902
15	127218		LINK.FRONT
16	73350800		NUT
17	130171		TRUNION
18	73800800		NUT.LK.W/WSH.1/2.
19	139868		ARM SUSP REAR
20	3146R		RETAINER.SPRING
23	110807X		NUT T
24	19131016		WASHER
25	2876H		SPRING T
26	76020308		SUB= 3145
27	126971X		SUB= 532126971
28	73350600		NUT
29	138057		KNOB INF 3/8-16
30	150233		TRUNNION
31	140302		BEARING PVT LH
32	73540600		NUT.CROWNLOCK.3/8
36	155097		POINTER-INDICAT
37	123935X		"PLUG,HOLE"
38	17490512		SCREW
40	19112410		WASHER
41	155098		INDICATOR HEIGHT
49	145212		NUT.HXFLG.LOCK.
50	110452X		NUT PUSH M



TRACTOR - MODEL NO.

(PP16H46B), PRODUCT NO. 954 19 00-12

PEERLESS TRANSAXLE - MODEL NUMBER 205-026B

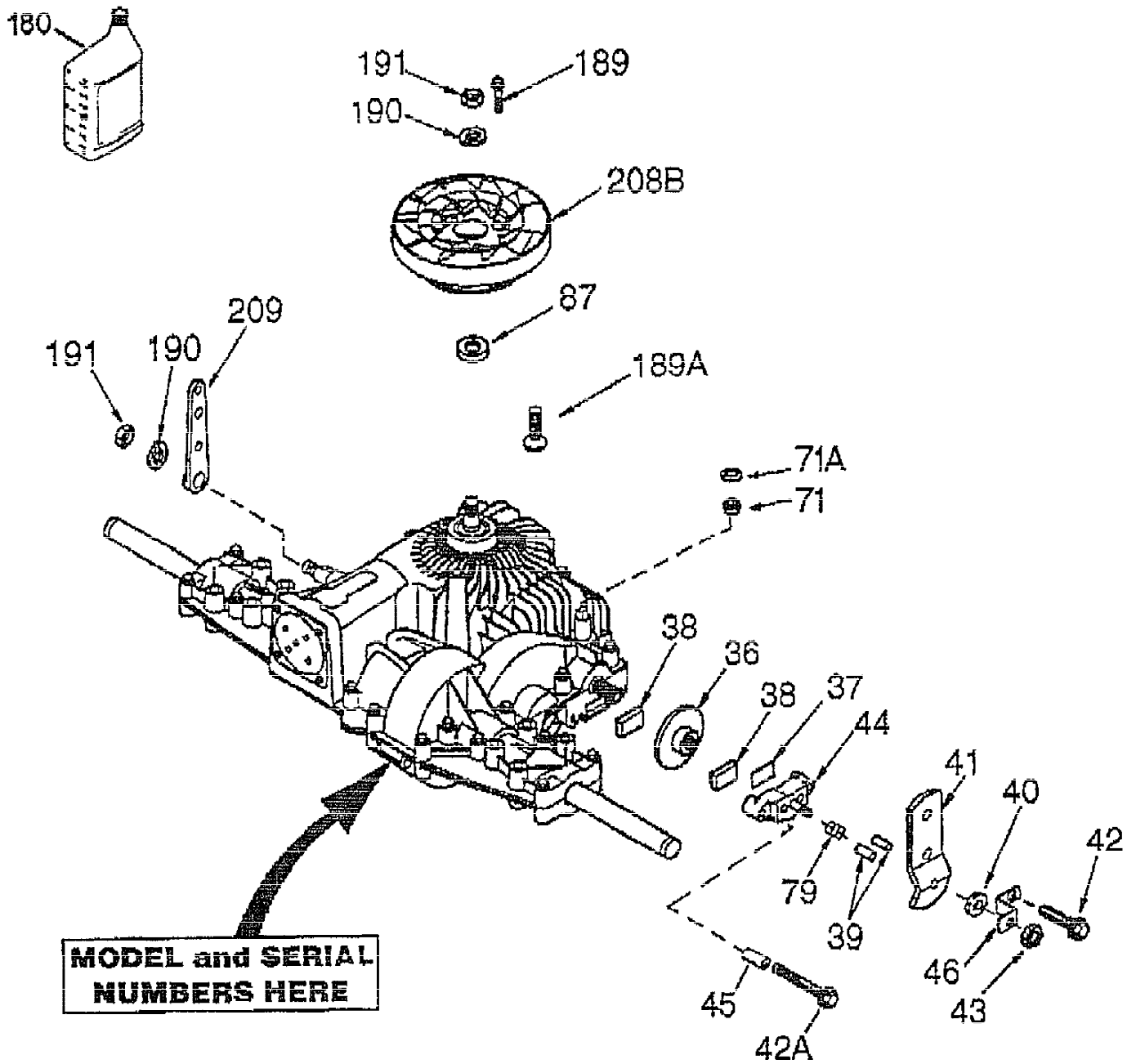

Ref #	Part Number	Qty	Description
	205-026B		TRANSAXLE, PEERLESS
36	790075		BRAKE DISC
37	790007		PLATE BRAKE PAD
38	799021		BRAKE PAD
39	786026		PIN DOWEL
40	792076A		WASHER
41	790085		BRAKE LEVER
42	792073		SCREW, 1/4-20 X 1-1/4
42A	792085A		SCREW, 1/4-20 X 2-1/4
43	792075		LOCKNUT 5/16-24
44	790025		HOLDER BRAKE PAD
45	786066		SPACER
46	790086		BRAKE LEVER BRACKET
71	788069		SEAL SQUARE CUT
71A	792162		PUSHNUT
79	792144		SPRING
87	788035		OIL SEAL
180	730229A		GEAR OIL 80W90
189	792168		DRIVE SCREW
189A	792169		SCREW
190	792150		LOCKWASHER
191	792151		NUT
208B	798025		FAN/COUPLING
209	798024		CONTROL LEVER

**TRACTOR - MODEL NUMBER**  
**SEAT ASSEMBLY**

**(PP16H46B), PRODUCT NO. 954 19 00-12**

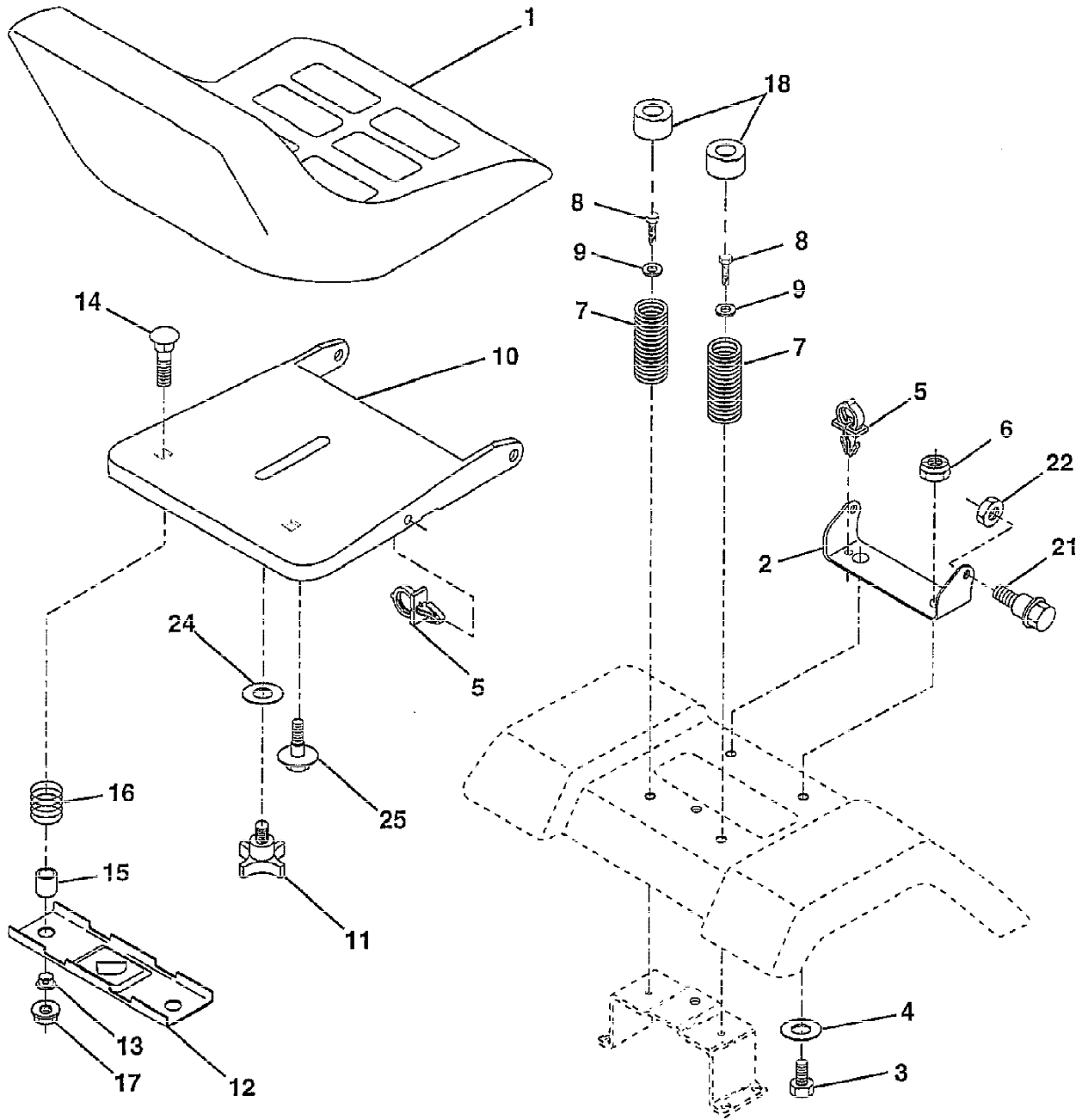

Ref #	Part Number	Qty	Description
1	140118		SEAT.2500/1516.BK
2	140551		BRACKET PVT SEAT
3	74760616		BOLT
4	19131610		WASHER PM
5	145006		CLIP.PUSH-IN.HING
6	73800600		NUT
7	124181		SPRING, COMPRESSION, SEAT
8	17490616		SCREW GTV
9	19131614		WASHER
10	155925		PAN-SEAT
11	120068X		"KNOB 1/2" YT"
12	121246X		BRKT SWITCH
13	121248X		BUSHING
14	72050411		SUB= 872050411
15	121249X		SPACER SPLIT
16	123740X		SPRING COMPRESSED
17	123976X		SUB= 73900400
18	124238X		CAP SPRING
21	153236		"BOLT,SHOULDER"
22	73800500		NUT
24	19171912		WASHER
25	127018X		"BOLT,SHOULDER"

TRACTOR - MODEL NUMBER  
STEERING ASSEMBLY

(PP16H46B), PRODUCT NO. 954 19 00-12

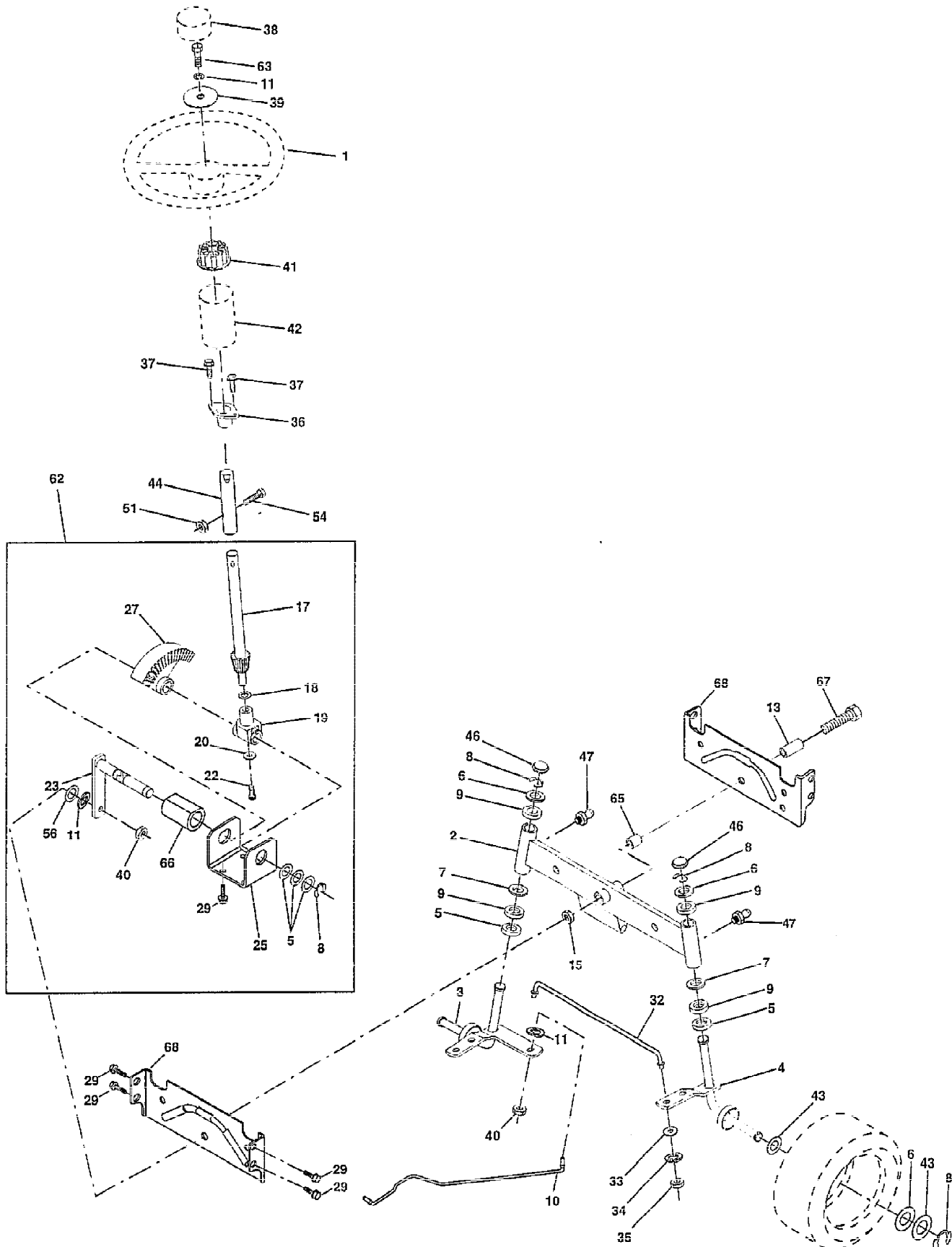

Ref #	Part Number	Qty	Description
1	121472X		SUB= 150546
2	154427		AXLE ASM
3	156483		SPINDLE.ASM.LH
4	157473		"SPINDLE ASM,RH"
5	6266H		WASHER .T
6	121748X		WASHER
7	19272016		WASHER
8	12000029		RING
9	3366R		COL. SRTG. BEAR.
10	156438		DRAGLINK-STAMPED
11	10040600		LOCKWASHER
13	154779		BEARING AXLE
15	73901000		"NUT-LOC,FLANGE LT"
17	156546		SHAFT ASM STEERIN
18	57079		THRUST WASHER
19	124035		SUPPORT SHAFT
20	126684		WASHER SHIM 1/4 X 5/8 X 062
22	71200410		SCREW HEX SOC1/4-
23	127501		SUB= 918127501
25	154406		BRKT-STEERING
27	136874		GEAR SECTOR
29	17490612		SCREW
32	139929		ROD.TIE.19.75
33	19111216		WASHER M
34	10040500		LOCKWASHER
35	73810500		NUT.LOCK.5/16-24
36	155099		BUSHING.STEERING
37	152927		"SCREW-TT,10-32 FL"
38	126805X		"INSERT,STR WHEEL"
39	19133808		WASHER T
40	7810H		GRIPCO NUT
41	100711L		ADAPTER LT
42	145054		BOOT.STEER.PL
43	121749X		WASHER
44	153720		EXT SHAFT STEERIN
46	121232X		CAP
47	6855M		ZERK M
51	73800500		NUT
54	74780520		BOLT
62	156594		KIT STEERING ASM
63	74780616		BOLT
65	154780		SPACER AXLE
66	154404		"BEARING-ARM,PITMA"
67	74781044		BOLT
68	154429		BRACE AXLE

# WHEELS & TIRES

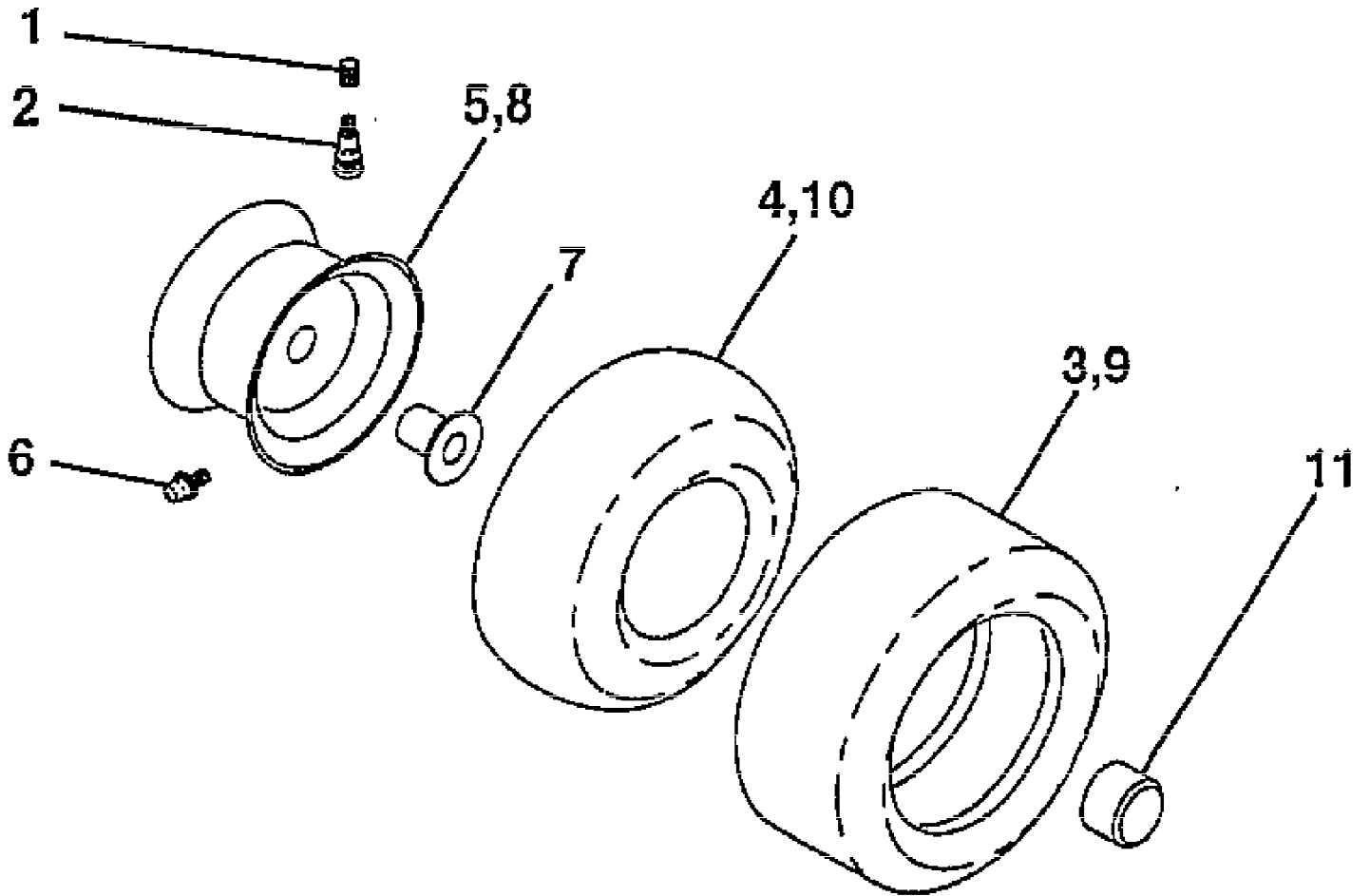

Ref #	Part Number	Qty	Description
1	59192		VALVE CAP
2	65139		VALVE STEM LT
3	106222X		SUB= 122073X
4	PARTSIMAGE		REFER TO PARTS IMAGE
4	59904		TUBE.5.3/4.5/6
5	106732X417		"RIM,FRT T"
6	278H		FITTING LT
7	9040H		"FLANGE, BEARING"
8	106108X417		"RIM 8""
9	122082X		SUB= 918122082X
10	PARTSIMAGE		REFER TO PARTS IMAGE
10	7152J		TUBE.18X9.5-8
11	104757X		HUB CAP
	144334		SEALANT.TIRE 10 OZ. TUBE