

Get it fixed, at your home or ours!

Just Call:

1-800-4-MY-HOME®

(1-800-469-4663)

24 hours a day, 7 days a week

For the repair of major brand appliances **in your own home...**
no matter who made it, no matter who sold it!

For your nearest **Sears Parts and Service** location,
to bring in products like vacuums, lawn equipment and electronics.

For **Sears Parts & Service**, to order the replacement parts,
accessories and owner's manuals that you need to do-it-yourself.

www.sears.ca

To purchase or inquire about a Sears Maintenance Agreement, call:

1-800-361-6665

9 a.m. – 8 p.m. EST, Mon. – Fri., 4 p.m. Sat.

Pour service en français:

1-800-LE-FOYER^{MC}

(1-800-533-6937)

www.sears.ca



Owner's Manual

CRAFTSMAN®

**6.75 HORSEPOWER
21" MULTI-CUT
POWER-PROPELLED
ROTARY LAWN MOWER**

Model No.
944.361281

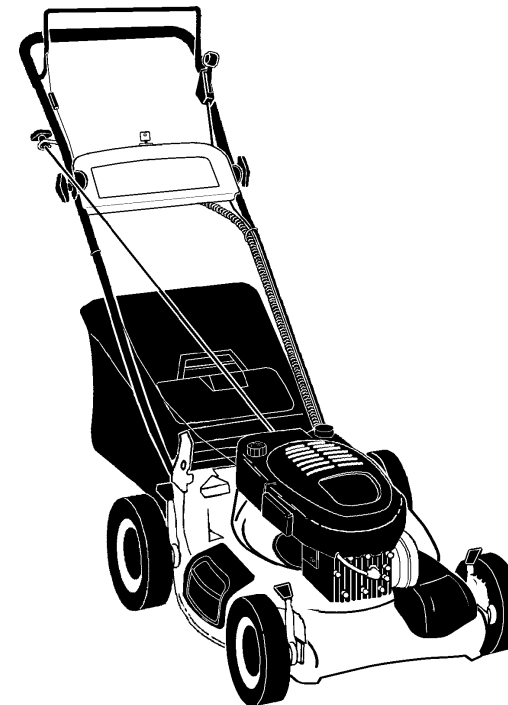

- **Safety**
- **Assembly**
- **Operation**
- **Maintenance**
- **Repair Parts**

The D.O.M. decal includes engine life specifications for the emissions-related useful life period of your engine. This period relates to the emission compliance life as certified by EPA/CARB. To find the life period specification for your engine, please match one of the following letters with the letter printed on your D.O.M. decal: (C) 125 hours, (B) 250 hours, (A) 500 hours.

CAUTION:

Read and follow all
Safety Rules and Instructions
before operating this equipment

Sears Canada, Inc., Toronto, Ontario M5B 2B8

® / TM Trademarks of Sears, Roebuck and Co. used under license by Sears Canada

MC / ^{MD} Marque de commerce / déposée de Sears, Roebuck and Co. utilisée en vertu d'une licence de Sears Canada

© Sears

TABLE OF CONTENTS

| | | | |
|----------------------------|-------|-------------------------------|------------|
| Warranty | 2 | Product Specifications | 12 |
| Safety Rules | 2-4 | Service and Adjustments | 15 |
| Assembly | 4-5 | Storage | 16-17 |
| Operation | 6-10 | Troubleshooting | 17-18 |
| Maintenance Schedule | 11 | Repair Parts | 19-27 |
| Maintenance | 11-14 | Parts Ordering | Back Cover |

WARRANTY

LIMITED TWO YEAR WARRANTY ON CRAFTSMAN POWER MOWER

For Two years from date of purchase Sears Canada, Inc. will repair or replace at Sears option free of charge parts which are defective as a result of material or workmanship. **COMMERCIAL OR RENTAL USE:**

Warranty on Power Mower (Gas) will be ninety (90) days from date of purchase if used for commercial or rental purposes.

This Warranty does **NOT** cover:

- Pre-delivery set-up.
- Expendable items which become worn during normal use, such as rotary mower blades, blade adapters, belts, air cleaners and spark plug.
- Repairs necessary because of operator abuse or negligence, including bent crankshafts and the failure to maintain the equipment according to the instructions contained in the owner's manual.

Warranty service is available by returning the Craftsman Power Mower to the nearest Sears Service Centre/Department in Canada. This warranty applies only while this product is in use in Canada.

This warranty is in addition to any statutory warranty and does not exclude or limit legal rights you may have but shall run concurrently with applicable provincial legislation. Furthermore, some provinces do NOT allow limitation on how long an implied warranty will last so the above limitations may not apply to you.

SEARS CANADA, INC., TORONTO, ONTARIO M5B 2B8

SAFETY RULES

IMPORTANT: This cutting machine is capable of amputating hands and feet and throwing objects. Failure to observe the following safety instructions could result in serious injury or death.

I. GENERAL OPERATION

- Read, understand, and follow all instructions on the machine and in the manual(s) before starting. Be thoroughly familiar with the controls and the proper use of the machine before starting.
- Do not put hands or feet near or under rotating parts. Keep clear of the discharge opening at all times.
- Only allow responsible individuals, who are familiar with the instructions, to operate the machine.
- Clear the area of objects such as rocks, toys, wire, bones, sticks, etc., which could be picked up and thrown by the blade.
- Be sure the area is clear of other people before mowing. Stop machine if anyone enters the area.
- Do not operate the mower when barefoot or wearing open sandals. Always wear substantial foot wear.
- Do not pull mower backwards unless absolutely necessary. Always look down and behind before and while moving backwards.
- Do not operate the mower without proper guards, plates, grass catcher or other safety protective devices in place.
- See manufacturer's instructions for proper operation and installation of accessories. Only use accessories approved by the manufacturer.
- Stop the blade(s) when crossing gravel drives, walks, or roads.
- Stop the engine (motor) whenever you leave the equipment, before cleaning the mower or unclogging the chute.

CRAFTSMAN 4-CYCLE ENGINE

MODEL NUMBER 143.016734

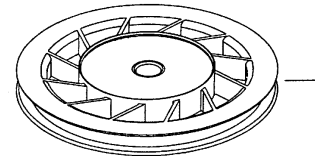
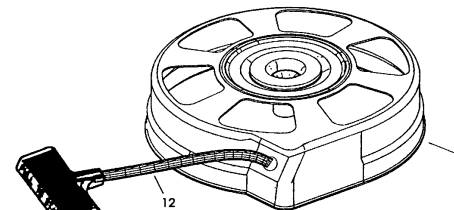
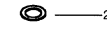
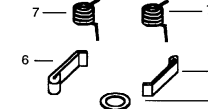
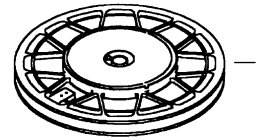
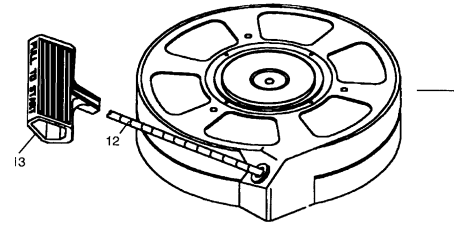

| KEY NO. | PART NO. | DESCRIPTION |
|---------|----------|--|
| — | 590702 | Recoil Starter |
| 1 | 590599A | Spring Pin (Includes Key #4) |
| 2 | 590600 | Washer |
| 3 | 590696 | Retainer |
| 4 | 590601 | Washer |
| 5 | 590697 | Brake Spring |
| 6 | 590698 | Starter Dog |
| 7 | 590699 | Dog Spring |
| 8 | 590700 | Pulley & Rewind Spring Assembly |
| 11 | 590703 | Starter Housing Assembly (40 degree grommet) |
| 12 | 590535 | Starter Rope (.98" x 9/64" diameter) |
| 13 | 590701 | Starter Handle |

| KEY NO. | PART NO. | DESCRIPTION |
|---------|----------|--|
| -- | 590739 | Rewind Starter |
| 3 | 590740 | Retainer |
| 6 | 590616 | Starter Dog |
| 7 | 590617 | Dog Spring |
| 8 | 590618A | Pulley & Rewind Spring Assembly |
| 11 | 590638 | Starter Housing Assembly (40 degree grommet) |
| 12 | 590535 | Starter Rope (.98" x 9/64" diameter) |
| 13 | 590701 | Starter Handle |
| 14 | 590760 | Spring Clip |

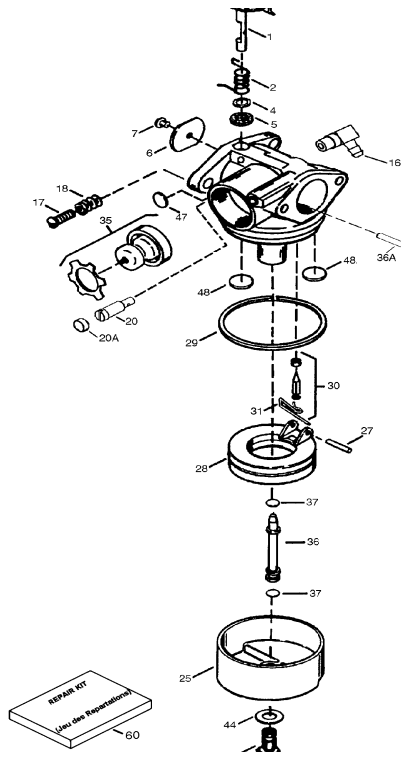

| KEY NO. | PART NO. | DESCRIPTION |
|---------|----------|---|
| --- | 640271 | Carburetor (Includes Key Number 184 of Engine Parts List) |
| 1 | 31615 | Throttle Shaft & Lever Assembly |
| 2 | 31767 | Throttle Return Spring |
| 4 | 631184 | * Dust Seal Washer |
| 5 | 631183 | * Dust Seal (Throttle) |
| 6 | 640070 | Throttle Shutter |
| 7 | 650506 | * Shutter Screw |
| 16 | 631807 | Fuel Fitting |
| 17 | 651025 | Throttle Crack/Idle Speed Screw |
| 18 | 630766 | Tension Spring |
| 20 | 640027 | Idle Restrictor Screw |
| 20A | 640200 | Idle Restrictor Scrw Cap (Black) |
| 25 | 631867 | Float Bowl |
| 27 | 631024 | * Float Shaft |
| 28 | 632019 | Float |
| 29 | 631028 | * Float Bowl "O" Ring |
| 30 | 631021 | * Inlet Needle, Seat, & Clip (Incl. 31) |
| 31 | 631022 | Spring Clip |
| 35 | 640259 | Primer Bulb/Retainer Ring |
| 36 | 640080 | Main Nozzle Tube |
| 36A | 632766 | Carburetor Tube |
| 37 | 632547 | * "O" Ring, Main Nozzle Tube |
| 40 | 640030 | High Speed Bowl Nut |
| 44 | 27110A | * Bowl Nut Washer |
| 47 | 630748 | * Welch Plug, Idle Mixture Well |
| 48 | 631027 | * Welch Plug, Atmospheric Vent |
| 60 | 632760B | Repair kit (Incl. Items Marked *) |

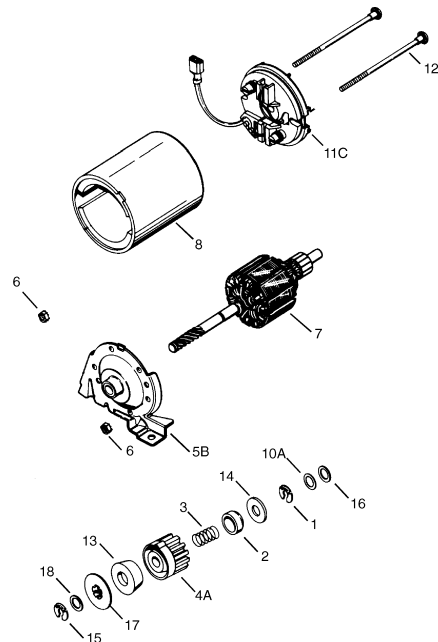

| KEY NO. | PART NO. | DESCRIPTION |
|---------|----------|--|
| -- | 35709 | Electric Starter (12 Volt) |
| 1 | 34955 | Retainer Ring |
| 2 | 34950 | Spring Retainer |
| 3 | 34954 | Spring |
| 4A | 34949A | Gear |
| 5B | 34953 | Drive End Cap Assembly |
| 6 | 33450 | Lock Nut |
| 7 | 34944 | Armature |
| 8 | 34945 | Housing Ass'y. |
| 10A | 590500 | Thrust Washer |
| 11C | 35714 | Commutator End Cap Assembly (Includes brushes) |
| 12 | 34947 | Bolt, 10-32 x 3-3/16" |
| 13 | 34946 | Pinion Driver |
| 14 | 34951 | Cup Washer |
| 15 | 34952 | Retainer Ring |
| 16 | 34948 | Washer |
| 17 | 34953 | Drive Nut |
| 18 | 590608 | Washer |

- Shut the engine (motor) off and wait until the blade comes to complete stop before removing grass catcher.
- Mow only in daylight or good artificial light.
- Do not operate the machine while under the influence of alcohol or drugs.
- Never operate machine in wet grass. Always be sure of your footing; keep a firm hold on the handle and walk; never run.
- Disengage the self-propelled mechanism or drive clutch on mowers so equipped before starting the engine (motor).
- If the equipment should start to vibrate abnormally, stop the engine (motor) and check immediately for the cause. Vibration is generally a warning of trouble.
- Always wear safety goggles or safety glasses with side shields when operating mower.

II. SLOPE OPERATION

Slopes are a major factor related to slip and fall accidents which can result in severe injury. All slopes require extra caution. If you feel uneasy on a slope, do not mow it.

DO:

- Mow across the face of slopes: never up and down. Exercise extreme caution when changing direction on slopes.
- Remove obstacles such as rocks, tree limbs, etc.
- Watch for holes, ruts, or bumps. Tall grass can hide obstacles.

DO NOT:

- Do not trim near drop-offs, ditches or embankments. The operator could lose footing or balance.
- Do not trim excessively steep slopes.
- Do not mow on wet grass. Reduced footing could cause slipping.

III. CHILDREN

Tragic accidents can occur if the operator is not alert to the presence of children. Children are often attracted to the machine and the mowing activity. *Never* assume that children will remain where you last saw them.

- Keep children out of the trimming area and under the watchful care of another responsible adult.
- Be alert and turn machine off if children enter the area.

- Before and while walking backwards, look behind and *down* for small children.
- Never allow children to operate the machine.
- Use extra care when approaching blind corners, shrubs, trees, or other objects that may obscure vision.

IV. SERVICES

- Use extra care in handling gasoline and other fuels. They are flammable and vapors are explosive.
 - Use only an approved container.
 - Never remove gas cap or add fuel with the engine running. Allow engine to cool before refueling. Do not smoke.
 - Never refuel the machine indoors.
 - Never store the machine or fuel container inside where there is an open flame, such as a water heater.
- Never run a machine inside a closed area.
- Never make adjustments or repairs with the engine (motor) running. Disconnect the spark plug wire, and keep the wire away from the plug to prevent accidental starting.
- Keep nuts and bolts, especially blade attachment bolts, tight and keep equipment in good condition.
- Never tamper with safety devices. Check their proper operation regularly.
- Keep machine free of grass, leaves, or other debris build-up. Clean oil or fuel spillage. Allow machine to cool before storing.
- Stop and inspect the equipment if you strike an object. Repair, if necessary, before restarting.
- Never attempt to make wheel height adjustments while the engine (motor) is running.
- Grass catcher components are subject to wear, damage, and deterioration, which could expose moving parts or allow objects to be thrown. Frequently check components and replace with manufacturer's recommended parts, when necessary.
- Mower blades are sharp and can cut. Wrap the blade(s) or wear gloves, and use extra caution when servicing them.
- Do not change the engine governor setting or overspeed the engine.

⚠ Look for this symbol to point out important safety precautions. It means **CAUTION!!! BECOME ALERT!!! YOUR SAFETY IS INVOLVED.**

⚠ CAUTION: Always disconnect spark plug wire and place wire where it cannot contact spark plug in order to prevent accidental starting when setting up, transporting, adjusting or making repairs.

⚠ CAUTION: Muffler and other engine parts become extremely hot during operation and remain hot after engine has stopped. To avoid severe burns on contact, stay away from these areas.



ASSEMBLY

Read these instructions and this manual in its entirety before you attempt to assemble or operate your new lawn mower.

IMPORTANT: This lawn mower is shipped **WITHOUT OIL OR GASOLINE** in the engine.

Your new lawn mower has been assembled at the factory with the exception of those parts left unassembled for shipping purposes. All parts such as nuts, washers, bolts, etc., necessary to complete the assembly have been placed in the parts bag. To ensure safe and proper operation of your lawn mower, all parts and hardware you assemble must be tightened securely. Use the correct tools as necessary to ensure proper tightness.

TO REMOVE LAWN MOWER FROM CARTON

1. Remove loose parts included with mower.
2. Cut down two end corners of carton and lay end panel down flat.
3. Remove all packing materials except padding between upper and lower handle and padding holding operator presence control bar to upper handle.
4. Roll lawn mower out of carton and check carton thoroughly for additional loose parts.

HOW TO SET UP YOUR LAWN MOWER

TO UNFOLD HANDLE

IMPORTANT: Unfold handle carefully so as not to pinch or damage control cables.

1. Raise handles until lower handle section locks into place in mowing position.
2. Remove protective padding, raise upper handle section into place on lower handle and tighten both handle knobs.
3. Remove handle padding holding operator presence control bar to upper handle.

Your lawn mower handle can be adjusted for your mowing comfort. Refer to "ADJUST HANDLE" in the Service and Adjustments section of this manual.

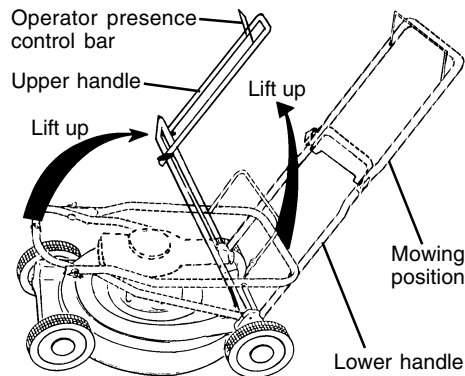

CRAFTSMAN 4-CYCLE ENGINE

MODEL NUMBER 143.016734

| KEY NO. | PART NO. | DESCRIPTION | KEY NO. | PART NO. | DESCRIPTION |
|---------|----------|--|---------|----------|---|
| 1 | 37465 | Cylinder (Includes Key #2 & 20) | 184 | 26756 | * Carburetor To Intake Pipe Gasket |
| 2 | 26727 | Dowel Pin | 185 | 37466 | Intake Pipe |
| 6 | 33734 | Breather Element | 186 | 32653 | Governor Link |
| 7 | 36557 | Breather Ass'y. (Incl. 6 & 12A) | 189 | 650831 | Screw, 1/4-20 x 1/2" |
| 12 | 36775 | Breather Tube | 191 | 36559 | S.E. Brake Bracket (Includes #195) |
| 12A | 36558 | Breather Cover & Tube (Incl. 12B) | 195 | 610973 | Terminal |
| 12B | 36694 | Breather Tube Elbow | 207 | 34336 | Throttle Link |
| 14 | 28277 | Washer | 216 | 33086 | R.P.M. Adjusting Lever |
| 15 | 30589 | Governor Rod (Includes Key #14) | 223 | 650451 | Screw, 1/4-20 x 1" |
| 16 | 34839A | Governor Lever | 224 | 36786 | Intake Pipe Gasket |
| 17 | 31335 | Governor Lever Clamp | 238 | 650932 | Screw, 10-32 x 49/64" |
| 18 | 651018 | Screw, T-15, 8-32 x 19/64" | 239 | 34338 | * Air Cleaner Gasket |
| 19 | 36281 | Extension Spring | 241 | 36919 | Air Cleaner Collar |
| 20 | 32600 | Oil Seal | 245 | 36905 | Air Cleaner Filter |
| 30 | 37464 | Crankshaft | 250 | 37122 | Air Cleaner Cover |
| 40 | 40027 | Piston, Pin & Ring Set (Std.) | 260 | 36980 | Blower Housing |
| 41 | 40042 | Piston & Pin Ass'y. (Std.) (Incl. 43) | 261 | 30200 | Screw, 10-24 x 9/16" |
| 42 | 40006 | Ring Set (Std.) | 262 | 650831 | Screw, 1/4-20 x 1/2" |
| 43 | 20381 | Piston Pin Retaining Ring | 263A | 37184 | Starter Grill |
| 45 | 36777 | Connecting Rod Ass'y. (Incl. 46) | 275 | 37462 | Muffler |
| 46 | 32610A | Connecting Rod Bolt | 277 | 650988 | Screw, 1/4-20 x 2-5/16" |
| 48 | 27241 | Valve Lifter | 285 | 35000A | Starter Cup |
| 50 | 37460 | Camshaft Exhaust(MCR) (Includes Key Number 104) | 287 | 650926 | Screw, 8-32 x 21/64" |
| 52 | 29914 | Oil Pump Assembly | 290 | 29774 | Fuel Line |
| 69 | 37609 | * Mounting Flange Gasket | 292 | 26460 | Fuel Line Clamp |
| 70 | 37608 | Mounting Flange (Incl. 72 thru 83) | 298 | 28763 | Screw, 10-32 x 35/64" |
| 72 | 37614 | Oil Drain Plug | 300 | 36916 | Fuel Tank (Includes #292 & 301) |
| 75 | 27897 | Oil Seal | 301 | 37656 | Fuel Cap Assembly |
| 80 | 30574A | Governor Shaft | 305 | 35647 | Oil Fill Tube |
| 81 | 30590A | Washer | 306 | 37610 | * "O"-Ring |
| 82 | 30591 | Governor Gear Assembly (Incl. 81) | 307 | 35499 | "O"-Ring |
| 83 | 30588A | Governor Spool | 309 | 650562 | Screw, 10-32 x 1/2" |
| 86 | 650488 | Screw, 1/4-20 x 1-1/4" | 309A | 650783 | Screw, 10-24 x 3/4" |
| 89 | 611004 | Flywheel Key | 310 | 35648 | Dipstick |
| 90 | 611150 | Flywheel | 311A | 37611 | Hold Down Bracket |
| 92 | 650815 | Belleville Washer | 313 | 34080 | Spacer |
| 93 | 650816 | Flywheel Nut | 314 | 650767 | Lockwasher & Screw 8-32 x 27/64" |
| 104 | 443C | Solid State Ignition | 315 | 36952 | Coil |
| 101 | 610118 | Spark Plug Cover | 322 | 35013 | Body Connector |
| 103 | 651007 | Screw, T-15, 10-24 x 15/16" | 322A | 610885 | Body Connector |
| 104 | 37480 | Cam Bushing | 325 | 35249 | Spring Clip |
| 110 | 37047 | Ground Wire | 347 | 65038 | Screw, 10-32 x 51/64" |
| 110A | 36953 | Wire Ass'y | 370A | 36261 | Lubrication Decal |
| 110B | 36954 | Wire Ass'y | 370C | 37318 | Primer Decal (3 X) |
| 119 | 36787 | * Cylinder Head Gasket | 370R | 37317 | Warning Decal |
| 120 | 36825 | Cylinder Head | 380 | 640271 | Carburetor (Includes Key No. 184) |
| 125 | 36780 | Exhaust Valve (1/32" OS) (Includes Key Number 151) | 390 | 590739 | Rewind Starter |
| | 37288 | Intake Valve (Std.) (Incl. 151) | 395 | 35709 | Electric Motor |
| 126 | 37289 | Screw, 5/16-18 x 1-1/2" | 400 | 37613 | Gasket Set (Incl. Items Marked*) |
| 130 | 6021A | Resistor Spark Plug (RJ19LM4) | 416 | 36085 | Spark Arrestor Kit (Optional) (Includes Key Number 417) |
| 135 | 37598 | Valve Spring | 417 | 650760 | Screw, 8-32 x 3/8" (Optional) |
| 150 | 31672 | Valve Spring Cap | 900 | 750865 | Replacement S/B order from 71-999 |
| 151 | 31673 | Intake Valve Seal | 900 | 750867A | Rep. Engine order from 71-999 |
| 151A | 40017 | Valve Cover Gasket | -- | -- | RPM High 2900 to 3200 |
| 169 | 36783 | Valve Cover | | | |
| 172 | 36784 | Screw, 10-24 x 9/16" | | | |
| 174 | 30200 | Nut & Lock Washer, 1/4-28 | | | |
| 178 | 29752 | Screw, 1/4-28 x 7/8" | | | |
| 182 | 6201 | | | | |

NOTE: This engine could have been built with 590702 starter.

NOTE: All component dimensions given in U.S. inches
1 inch = 25.4 mm

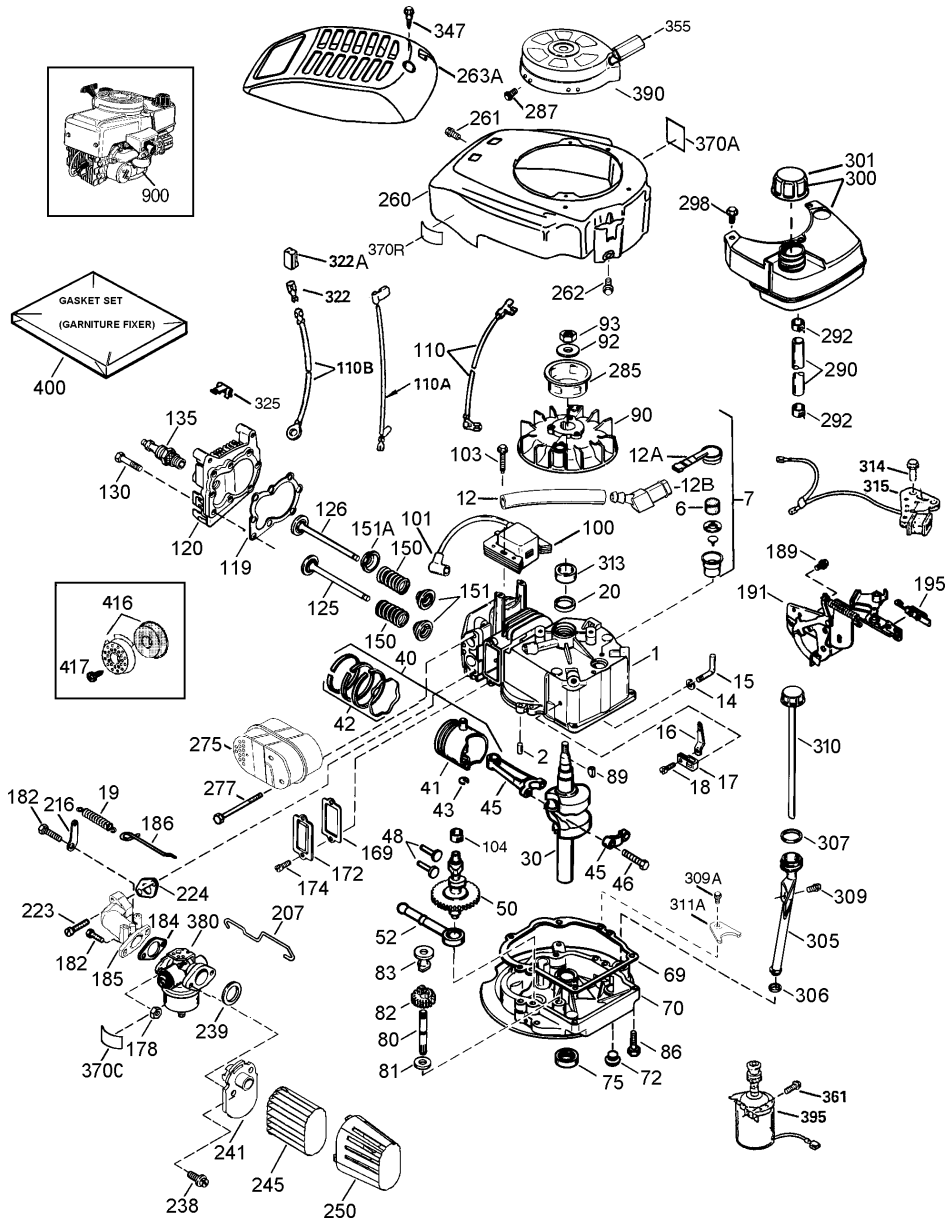

TO ASSEMBLE GRASS CATCHER

1. Put grass catcher frame into grass bag with rigid part of bag on the bottom. Make sure the frame handle is outside of the bag top.
 2. Slip vinyl bindings over frame.
- NOTE:** If vinyl bindings are too stiff, hold them in warm water for a few minutes. If bag gets wet, let it dry before using.
- CAUTION:** Do not run your lawn mower without clipping deflector or approved grass catcher in place. Never attempt to operate the lawn mower with the rear door removed or propped open.

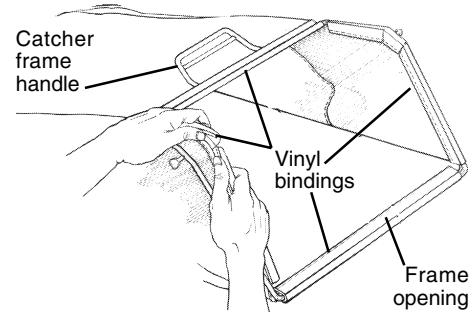

TO INSTALL ATTACHMENTS

Your lawn mower was shipped ready to be used as a mulcher. To convert to bagging or discharging, see "TO CONVERT MOWER" in the Operation section of this manual.

TO PREPARE BATTERY

- NOTE:** Your battery must be charged before you can start your lawn mower.
1. Disconnect engine battery connector (male) from battery connector (female)
 2. Connect battery charger connector (male) to battery connector (female).
 3. Plug battery charger into 110 volt A.C. outlet.
 4. Leave battery charger connected for 24 hours before starting your engine for the first time.
 5. After charging, connect engine connector (male) to battery connector (female).

Your engine has an integral alternator for partial charging. Connect your battery charger to charge battery as required.

IMPORTANT: The engine alternator will not charge a discharged battery. At the end of the mowing season the battery should be charged for 48 hours to protect the battery during winter storage.

CAUTION: Always disconnect the engine connector (male) from the battery connector (female) to prevent accidental starting when transporting or storing your lawn mower after the season.

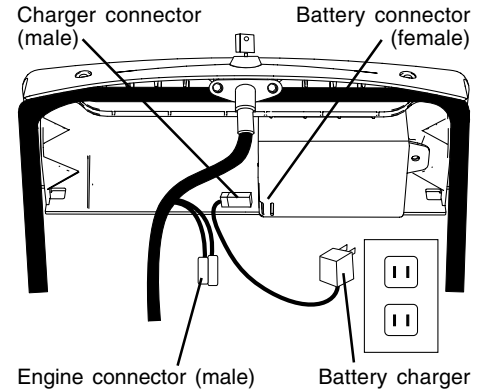

OPERATION

KNOW YOUR LAWN MOWER

READ THIS OWNER'S MANUAL AND SAFETY RULES BEFORE OPERATING YOUR LAWN MOWER. Compare the illustrations with your lawn mower to familiarize yourself with the location of various controls and adjustments. Save this manual for future reference.

These symbols may appear on your lawn mower or in literature supplied with the product. Learn and understand their meaning.

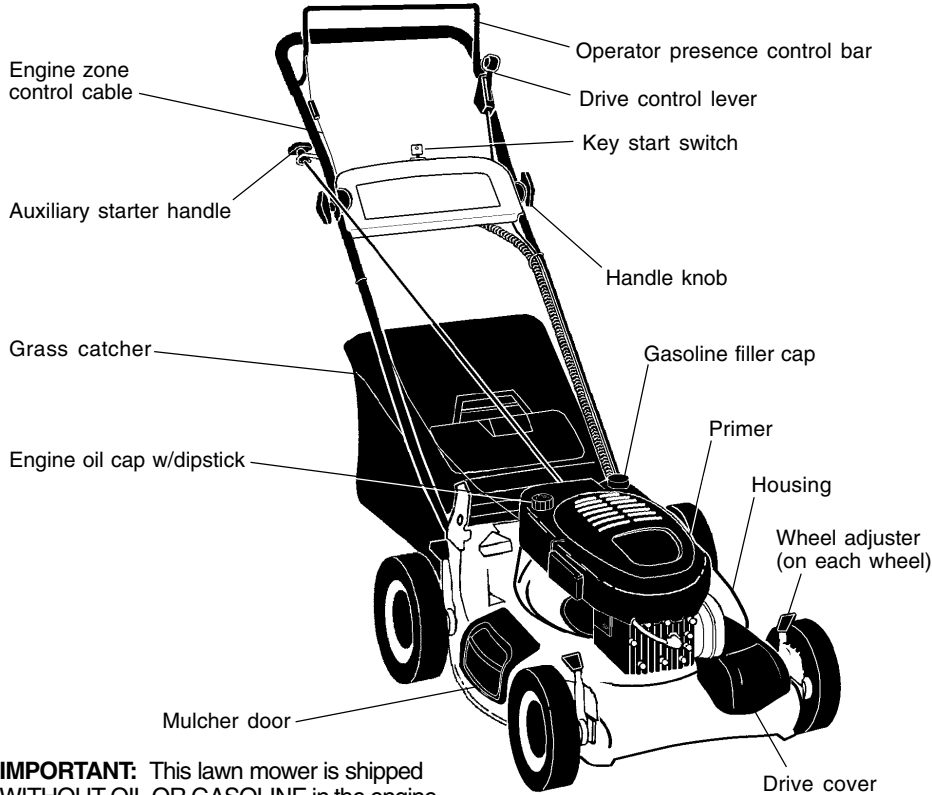
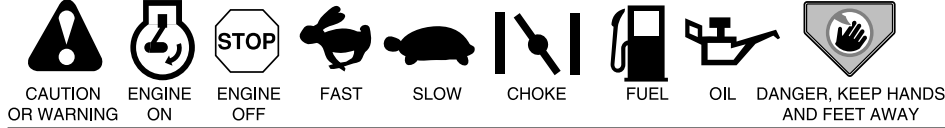

IMPORTANT: This lawn mower is shipped WITHOUT OIL OR GASOLINE in the engine.

MEETS CPSC SAFETY REQUIREMENTS

Sears rotary walk-behind power lawn mowers conform to the safety standards of the American National Standards Institute and the U.S. Consumer Product Safety Commission. The blade turns when the engine is running.

Operator presence control bar - must be held down to the handle to start the engine. Release to stop the engine.
Primer - pumps additional fuel from the carburetor to the cylinder for use when starting a cold engine.
Auxiliary starter handle - used for starting the engine.

Drive control lever – used to engage power-propelled forward motion lawn mower.
Key start switch– used for starting the engine.
Mulcher door – allows conversion to discharging or bagging operation.

CRAFTSMAN ROTARY LAWN MOWER -- MODEL NUMBER 944.361281

| KEY NO. | PART NO. | DESCRIPTION | KEY NO. | PART NO. | DESCRIPTION |
|---------|----------|---------------------------------------|---------|----------|---------------------------------|
| 1 | 145755 | Control Cable Assembly | 28 | 175065 | Drive Cover |
| 3 | 751152 | Locknut #10-24 | 31 | 132010 | Hex Flange Nut |
| 4 | 158755 | Hex Washer Head Screw 1/4-20 x 2.12 | 32 | 137052 | Drive Pulley |
| 5 | 175436 | V-Belt | 36 | 151521 | Wheel Adjuster Assembly (Left) |
| 6 | 150495 | Spring Retainer | 36 | 175258 | Gear Case Assembly |
| 8 | 175012 | Hubcap | 37 | 137090 | Spring |
| 9 | 145212 | Locknut | 38 | 63601 | Locknut 1/4-20 |
| 11 | 150340 | Wheel & Tire Assembly | 40 | 75192 | Spring |
| 12 | 12000058 | E-Ring | 41 | 151520 | Wheel Adjuster Assembly (Right) |
| 13 | 137054 | Pinion | 54 | 177426 | Grassbag Assembly |
| 14 | 88080 | Dust Cover | 55 | 175739 | Driveshaft Cover |
| 15 | 88118 | Felt Washer | 57 | 175058 | Frame |
| 16 | 67725 | Washer 1/2 x 1-1/2 x .134 | | | |
| 18 | 701037 | Selector Knob | | | |
| 26 | 175262 | Pan Head Tapping Screw #10-24 x 2-3/4 | | | |

NOTE: All component dimensions given in U.S. inches.
 1 inch = 25.4 mm

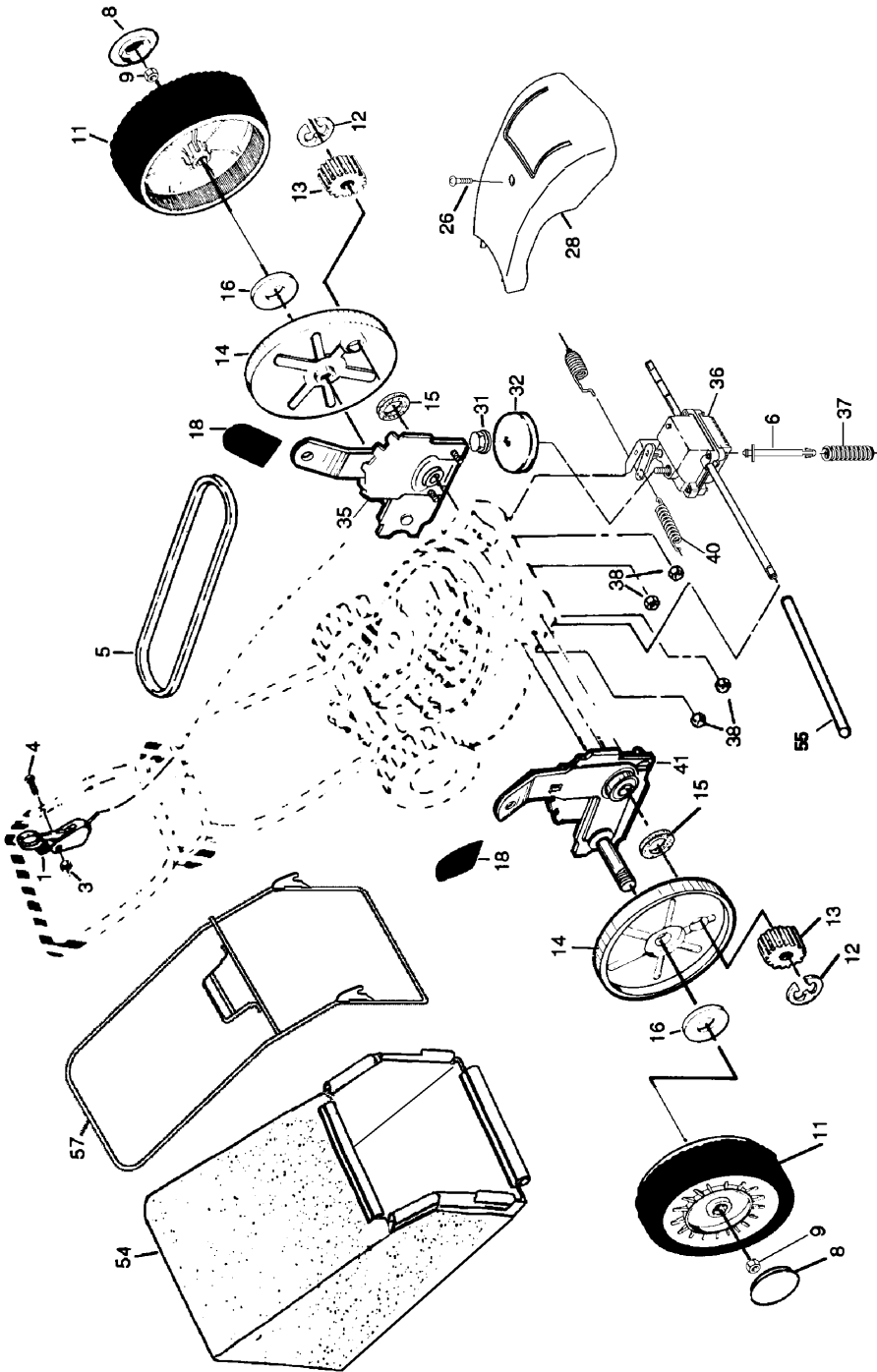

The operation of any lawn mower can result in foreign objects thrown into the eyes, which can result in severe eye damage.

Always wear safety glasses or eye shields while operating your lawn mower or performing any adjustments or repairs. We recommend a wide vision safety mask over spectacles or standard safety glasses.

HOW TO USE YOUR LAWN MOWER ENGINE SPEED

The engine speed was set at the factory for optimum performance. Speed is not adjustable.

ENGINE ZONE CONTROL

CAUTION: Federal regulations require an engine control to be installed on this lawn mower in order to minimize the risk of blade contact injury. Do not under any circumstances attempt to defeat the function of the operator control. The blade turns when the engine is running.

- Your lawn mower is equipped with an operator presence control bar which requires the operator to be positioned behind the lawn mower handle to start and operate the lawn mower.

DRIVE CONTROL

- Self-propelling is controlled by holding the operator presence control bar down to the handle and pushing the drive control lever forward until it clicks; then releasing the lever.
- Forward motion will stop when the operator presence control bar is released. To stop forward motion without stopping engine, release the operator presence control bar slightly until the drive control disengages. Hold operator presence control bar down against handle to continue mowing without self-propelling.

- To keep drive control engaged when turning corners, push down on handle and lift front wheels off ground while turning lawn mower.

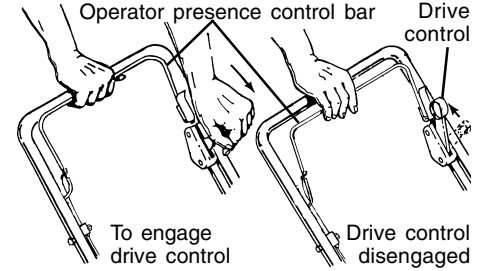

TO ADJUST CUTTING HEIGHT

Raise wheels for low cut and lower wheels for high cut. Adjust cutting height to suit your requirements. Medium position is best for most lawns.

- To change cutting height, squeeze adjuster lever toward wheel. Move wheel up or down to suit your requirements. Be sure all wheels are in the same setting.

NOTE: Adjuster is properly positioned when plate tab inserts into hole in lever. Also, 9-position adjusters (if so equipped) allow lever to be positioned between the plate tabs.

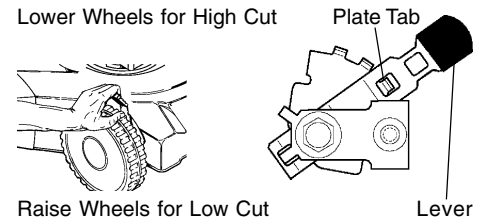

TO CONVERT MOWER

Your lawn mower was shipped ready to be used as a mulcher. To convert to bagging or discharging:

REAR BAGGING

- Lift rear door of the lawn mower and place the grass catcher frame hooks onto the door pivot pins.
- To convert to mulching or discharging operation, remove grass catcher and close rear door.

SIDE DISCHARGING

- Rear door must be closed.
- Open mulcher door and install discharge deflector under guard as shown.
- Mower is now ready for discharging operation.
- To convert to mulching or bagging operation, discharge deflector must be removed and mulcher door must be closed.

SIMPLE STEPS TO REMEMBER WHEN CONVERTING YOUR LAWN MOWER

FOR MULCHING -

1. Rear door closed.
2. Mulcher door closed.

FOR REAR BAGGING -

1. Grass catcher installed.
2. Mulcher door closed.

FOR SIDE DISCHARGING -

1. Rear door closed.
2. Side discharge deflector installed.

CAUTION: Do not run your lawn mower without rear door closed or approved grass catcher in place. Never attempt to operate the lawn mower with the rear door removed or propped open.

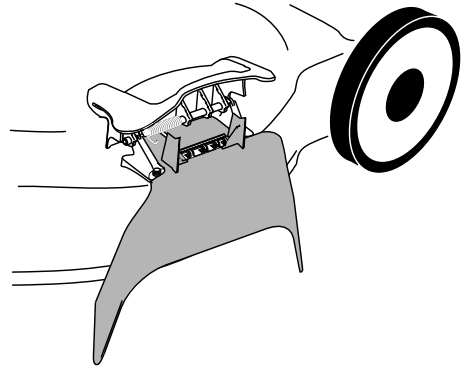
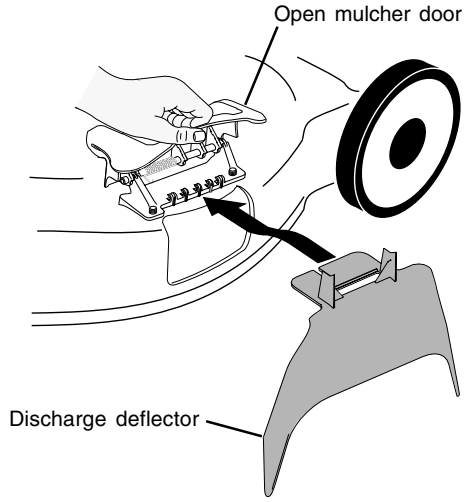
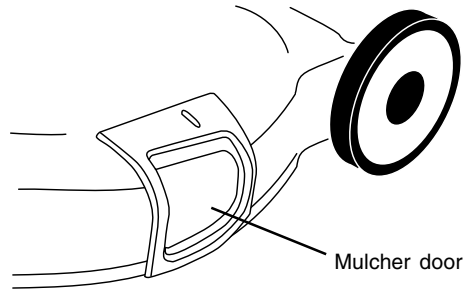
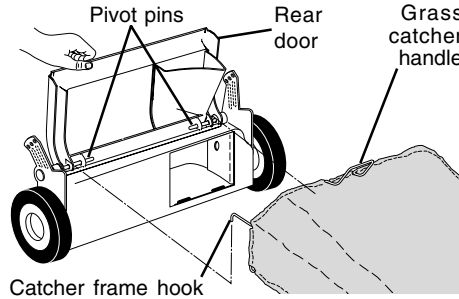

CRAFTSMAN ROTARY LAWN MOWER -- MODEL NUMBER 944.361281

| KEY PART NO. NO. | DESCRIPTION | KEY PART NO. NO. | DESCRIPTION |
|------------------|--|------------------|--|
| 1 | 175391X479 Upper Handle | 35 | 175012 Hubcap |
| 2 | 175245X479 Lower Handle | 36 | 165912 Bolt |
| 3 | 169780 Control Bar | 38 | 176185 Washer |
| 4 | 156577 Engine Zone Control Cable | 39 | 176235 Push Nut |
| 5 | 171407 Handle Bolt | 43 | 175083 Bottom Belt Cover |
| 6 | 136376 Handle Knob | 44 | 177433 Lawn Mower Housing (Incl. Key #10, 11, 12 & 45) |
| 7 | 51793 Hairpin Cotter | 45 | 107339X Danger/Decal |
| 8 | 66426 Wire Tie | 46 | 851514 Blade Adapter |
| 9 | 175794 Rear Door Kit (Incl. Key #16 & 17) | 47 | 175064 Blade 21" |
| 10 | 128415 Pop Rivet | 48 | 851074 Hardened Washer |
| 11 | 175069X479 Support Bracket LH | 49 | 850263 Helical Washer 3/8-24 x 1-3/8 Gr. 8 |
| 12 | 175070X479 Support Bracket RH | 50 | 851084 Hex Head Machine Screw 3/8-24 x 1-3/8 Gr. 8 |
| 13 | 17060410 Screw 14-20 x 5/8 | 78 | 179752 Handle Adjuster Assembly, LH |
| 14 | 175082X479 Handle Bracket Assembly (Left) | 79 | 179753 Handle Adjuster Assembly, RH |
| 15 | 175081X479 Handle Bracket Assembly (Right) | 85 | 175551 Bolt, Shoulder |
| 16 | 175243 Spring LH | 86 | 17411312 Screw, Hex Head |
| 17 | 175244 Spring RH | 87 | 175273 Box, Battery |
| 18 | 63601 Keps Locknut 1/4-20 | 88 | 750909 Battery |
| 19 | 153638 Rope Guide | 89 | 175271 Trim Plate |
| 20 | 178398 Rear Skirt | 90 | 141841 Screw |
| 21 | 88652 Hinge Screw 1/4-20 x 1-1/4 | 91 | 175552 Control Cable (Includes Key) |
| 22 | 85543 Engine Pulley | 92 | 111549X Charger, Battery |
| 23 | 87677 Hi-Pro Key #505 | 93 | 175066 Mulcher Door |
| 24 | 150406 Engine-Craftsman-Model No. 143.016734 | 94 | 175735 Hinge Bracket |
| 25 | 83923 Hex Head Thread Rolling Screw 3/8-16 x 1-1/8 | 95 | 175285 Spring |
| 26 | 150341 Wheel | 96 | 175650 Rod, Hinge |
| 27 | 175231 Shoulder Bolt | 98 | 86353 Connector, Mounting Clip |
| 28 | 132004 Nut, Hex 1/4-20 | 99 | 175071 Discharge Deflector |
| 29 | 165761X004 Axle Arm Assembly RR | - - | 162300 Warning Decal (Not Shown) |
| 30 | 701037 Selector Knob | - - | 179363 Owner's Manual (English) |
| 31 | 175060X004 Selector Spring | - - | 179364 Owner's Manual (French) |
| 32 | 165762X004 Axle Arm Assembly LR | | |
| 34 | | | |

NOTE: All component dimensions given in U.S. inches.
1 inch = 25.4 mm

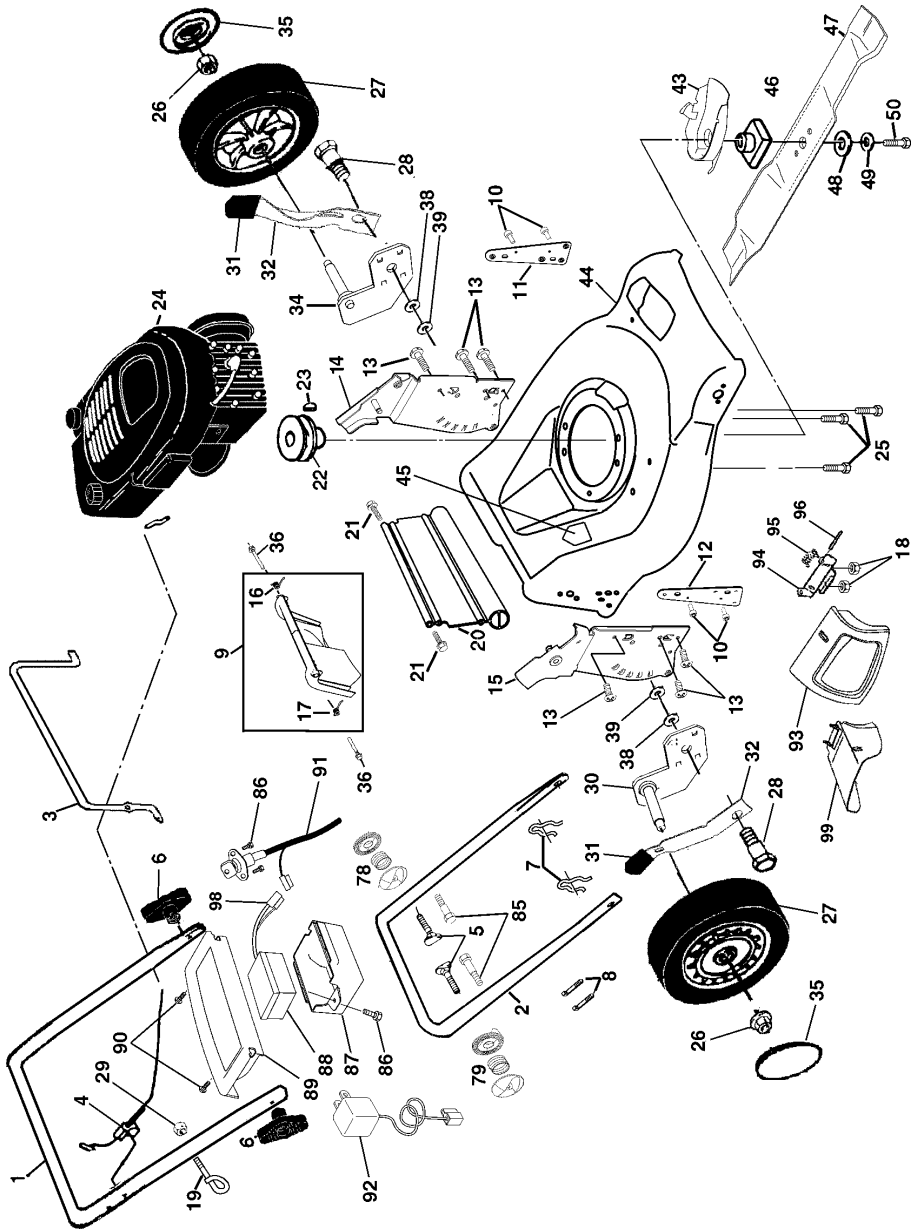

BEFORE STARTING ENGINE

ADD OIL

Your lawnmower is shipped without oil in the engine. Engine holds 20 oz. of oil. For type and grade of oil to use, see "ENGINE" in Maintenance section of this manual.

1. Be sure lawnmower is level and area around oil fill is clean.
2. Remove engine oil cap and fill to the full line on the dipstick. Pour oil slowly. Do not over fill.

NOTE: Allow oil to settle down into engine for accurate reading. To read proper level, tighten engine oil cap, then remove it to read the dipstick.

3. Reinstall engine oil cap and tighten.
 - Check oil level before each use. Add oil if needed. Fill to full line on dipstick.
 - Change the oil after every 25 hours of operation or each season. You may need to change the oil more often under dusty, dirty conditions.

ADD GASOLINE

- Fill fuel tank. Use fresh, clean, regular unleaded gasoline with a minimum of 87 octane. Do not mix oil with gasoline. Purchase fuel in quantities that can be used within 30 days to assure fuel freshness.

⚠WARNING: Experience indicates that alcohol blended fuels (called gasohol or using ethanol or methanol) can attract moisture which leads to separation and formation of acids during storage. Acidic gas can damage the fuel system of an engine while in storage. To avoid engine problems, the fuel system should be emptied before storage of 30 days or longer. Drain the gas tank and let it run until the fuel lines and carburetor are empty. Use fresh fuel next season. See Storage Instructions for additional information. Never use engine or carburetor cleaner products in the fuel tank or permanent damage may occur.

⚠CAUTION: Fill to bottom of gas tank filler neck. Do not overfill. Wipe off any spilled oil or fuel. Do not store, spill or use gasoline near an open flame.

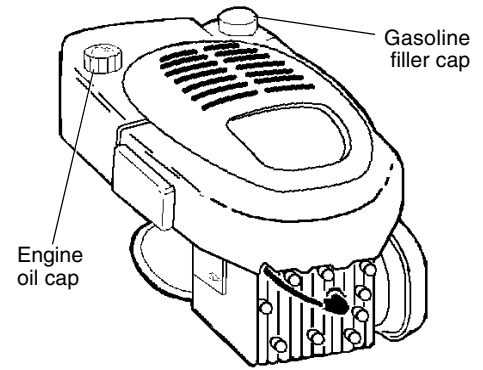

TO START ENGINE

NOTE: Due to protective coatings on the engine, a small amount of smoke may be present during the initial use of the product and should be considered normal.

1. To start a cold engine, push primer three (3) times before trying to start. Use a firm push. This step is not usually necessary when starting an engine which has already run for a few minutes.
2. Hold operator presence control bar down to the handle.
3. Turn electric start key clockwise to crank engine.

IMPORTANT: Do not crank engine more than five continuous seconds between each time you try to start. Wait 5 to 10 seconds between each attempt.

1. To start engine using the auxiliary starter handle, follow the steps above. Exchange the use of the start key for starter handle. Pull starter handle quickly. Do not allow starter rope to snap back.

TO STOP ENGINE

- To stop engine, release operator presence control bar.

NOTE: In cooler weather it may be necessary to repeat priming steps. In warmer weather over priming may cause flooding and engine will not start. If you do flood engine wait a few minutes before attempting to start and do not repeat priming steps.

MOWING TIPS

- Under certain conditions, such as very tall grass, it may be necessary to raise the height of cut to reduce pushing effort and to keep from overloading the engine and leaving clumps of grass clippings. It may also be necessary to reduce ground speed and/or run the lawn mower over the area a second time.
- For extremely heavy cutting, reduce the width of cut by overlapping previously cut path and mow slowly.
- For better grass bagging and most cutting conditions, the engine speed should be set in the fast position.
- Pores in cloth grass catchers can become filled with dirt and dust with use and catchers will collect less grass. To prevent this, regularly hose catcher off with water and let dry before using.
- Keep top of engine around starter clear and clean of grass clippings and chaff. This will help engine air flow and extend engine life.

MULCHING MOWING TIPS

IMPORTANT: For best performance, keep mower housing free of built-up grass and trash. See "CLEANING" in Maintenance section of this manual.

- The special mulching blade will recut the grass clippings many times and reduce them in size so that as they fall onto the lawn they will disperse into the grass and not be noticed. Also, the mulched grass will biodegrade quickly to provide nutrients for the lawn. Always mulch with your highest engine (blade) speed as this will provide the best recutting action of the blades.
- Avoid cutting your lawn when it is wet. Wet grass tends to form clumps and interferes with the mulching action. The best time to mow your lawn is the early afternoon. At this time the grass has dried and the newly cut area will not be exposed to the direct sun.
- For best results, adjust the lawn mower cutting height so that the lawn mower cuts off only the top one-third of the grass blades. If the lawn is overgrown it will be necessary to raise the height of cut to reduce pushing effort and to keep from overloading the engine and leaving clumps of mulched grass. For extremely heavy mulching, reduce your width of cut by overlapping previously cut path and mow slowly.
- Certain types of grass and grass conditions may require that an area be mulched a second time to completely hide the clippings. When doing a second cut, mow across or perpendicular to the first cut path.
- Change your cutting pattern from week to week. Mow north to south one week then change to east to west the next week. This will help prevent matting and graining of the lawn.

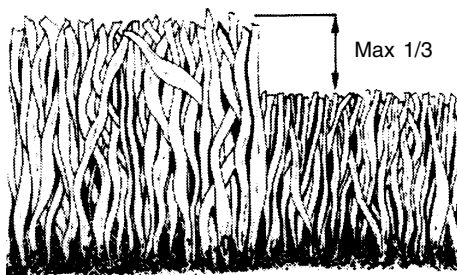

REPAIR PARTS

CRAFTSMAN ROTARY LAWN MOWER -- MODEL NUMBER 944.361281 GEAR CASE ASSEMBLY -- PART NUMBER 175258

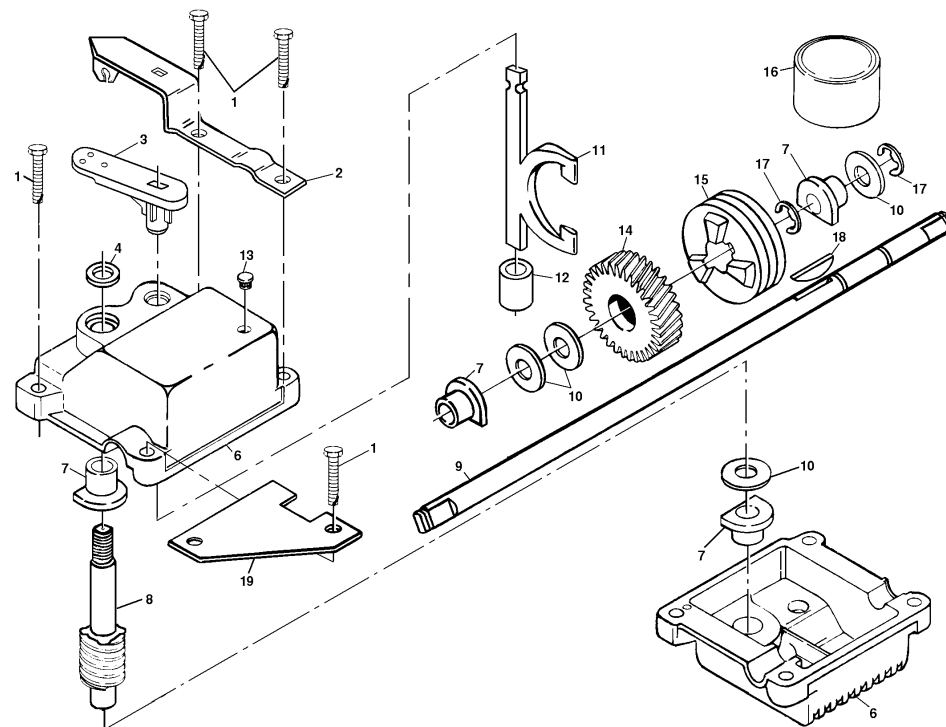

| KEY NO. | PART NO. | DESCRIPTION |
|---------|------------|--|
| 1 | 17490416 | Tapping Screw 1/4-20 x 1-1/4 |
| 2 | 175248X004 | Engagement Bracket |
| 3 | 137053 | Shifter |
| 4 | 57072 | Seal |
| 6 | 48373 | Gear Case Halves Kit (Includes Key Nos. 4 and 7) |
| 7 | 77881 | Bearing |
| 8 | 137051 | Worm Shaft |
| 9 | 175257 | Drive Shaft |
| 10 | 57079 | Hardened Washer |
| 11 | 131484 | Clutch Yoke |
| 12 | 700343 | Bushing |
| 13 | 86447 | Plug |
| 14 | 137050 | Helical Gear |
| 15 | 750436X | Clutch Jaw |
| 16 | 750369 | Grease |
| 17 | 12000003 | E-Ring |
| 18 | 850848 | Hi-Pro Key |
| 19 | 81585X004 | Spring Bracket |

NOTE: All component dimensions given in U.S. inches.
1 inch = 25.4 mm

PRODUCT SPECIFICATIONS

| | |
|---|---|
| SERIAL NUMBER: | |
| DATE OF PURCHASE: | |
| GASOLINE CAPACITY/TYPE: | 1.5 QUARTS (UNLEADED REGULAR) |
| OIL TYPE (API-SF-SJ): | SAE 30 (ABOVE 32°F); SAE 5W-30 (BELOW 32°F) |
| OIL CAPACITY: | 20 OUNCES |
| SPARK PLUG (GAP: .045") | CHAMPION RESISTOR TYPE RJ19LM4 |
| BLADE BOLT TORQUE: | 35-40 FT. LBS. |
| <ul style="list-style-type: none"> The model and serial numbers will be found on a decal on the rear of the mower housing. Record both serial number and date of purchase in space provided above. | |

LAWNMOWER

Always observe safety rules when performing any maintenance.

TIRES

- Keep tires free of gasoline, oil, or insect control chemicals which can harm rubber.
- Avoid stumps, stones, deep ruts, sharp objects and other hazards that may cause tire damage.

BLADE CARE

For best results, mower blade must be kept sharp. Replace bent or damaged blades.

TO REMOVE BLADE

1. Disconnect spark plug wire from spark plug and place wire where it cannot come in contact with spark plug.
2. Turn lawn mower on its side. Make sure air filter and carburetor are up.
3. Use a wood block between blade and mower housing to prevent blade from turning when removing blade bolt.

- NOTE:** Protect your hands with gloves and/or wrap blade with heavy cloth.
4. Remove blade bolt by turning counter-clockwise.
 5. Remove blade and attaching hardware (bolt, lock washer and hardened washer).

NOTE: Remove the blade adapter and check the key inside hub of blade adapter. The key must be in good condition to work properly. Replace adapter if damaged.

TO REPLACE BLADE

1. Position the blade adapter on the engine crankshaft. Be sure key in adapter and crankshaft keyway are aligned.
2. Position blade on the blade adapter aligning the two (2) holes in the blade with the raised lugs on the adapter.
3. Be sure the trailing edge of blade

- (opposite sharp edge) is up toward the engine.
4. Install the blade bolt with the lock washer and hardened washer into blade adapter and crankshaft.
 5. Use block of wood between blade and lawn mower housing and tighten the blade bolt, turning clockwise.
- The recommended tightening torque is 35-40 ft. lbs.

IMPORTANT: Blade bolt is grade 8 heat treated.

TO SHARPEN BLADE

NOTE: We do not recommend sharpening blade - but if you do, be sure the blade is balanced.

Care should be taken to keep the blade balanced. An unbalanced blade will cause eventual damage to lawn mower or engine.

- The blade can be sharpened with a file or on a grinding wheel. Do not attempt to sharpen while on the mower.
- To check blade balance, drive a nail into a beam or wall. Leave about one inch of the straight nail exposed. Place center hole of blade over the head of the nail. If blade is balanced, it should remain in a horizontal position. If either end of the blade moves downward, sharpen the heavy end until the blade is balanced.

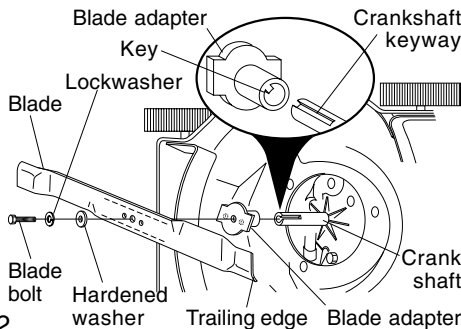

CYLINDER

1. Remove spark plug.
2. Pour one ounce (29 ml) of oil through spark plug hole into cylinder.
3. Pull starter handle slowly a few times to distribute oil.
4. Replace with new spark plug.

BATTERY

Disconnect the battery from the engine connector and charge battery 48 hours.

OTHER

- Do not store gasoline from one season to another.
- Replace your gasoline can if your can starts to rust. Rust and/or dirt in your gasoline will cause problems.

- If possible, store your unit indoors and cover it to give protection from dust and dirt.
- Cover your unit with a suitable protective cover that does not retain moisture. Do not use plastic. Plastic cannot breathe, which allows condensation to form and will cause your unit to rust.

IMPORTANT: Never cover mower while engine and exhaust areas are still warm.

CAUTION: Never store the lawn mower with gasoline in the tank inside a building where fumes may reach an open flame or spark. Allow the engine to cool before storing in any enclosure.

TROUBLESHOOTING CHART

| PROBLEM | CAUSE | CORRECTION |
|-----------------------|---|---|
| Does not start | <ol style="list-style-type: none"> 1. Dirty air filter. 2. Out of fuel. 3. Stale fuel. 4. Water in fuel. 5. Spark plug wire is disconnected. 6. Bad spark plug. 7. Loose blade or broken blade adapter. 8. Control bar in released position. 9. Control bar defective. | <ol style="list-style-type: none"> 1. Clean/replace air filter. 2. Fill fuel tank. 3. Drain tank and refill with fresh, clean fuel. 4. Drain fuel tank and carburetor and refill tank with fresh gasoline. 5. Connect wire to plug. 6. Replace spark plug. 7. Tighten blade bolt or replace blade adapter. 8. Depress control bar to handle. 9. Replace control bar. |
| Loss of power | <ol style="list-style-type: none"> 1. Rear of lawn mower housing or cutting blade dragging in heavy grass. 2. Cutting too much grass. 3. Dirty air filter. 4. Buildup of grass, leaves, and trash under mower. 5. Too much oil in engine. 6. Walking speed too fast. | <ol style="list-style-type: none"> 1. Set to "Higher Cut" position. 2. Set to "Higher Cut" position. 3. Clean/replace air filter. 4. Clean underside of mower housing. 5. Check oil level. 6. Cut at slower walking speed. |

STORAGE

Immediately prepare your lawn mower for storage at the end of the season or if the unit will not be used for 30 days or more.

LAWN MOWER

When lawn mower is to be stored for a period of time, clean it thoroughly, remove all dirt, grease, leaves, etc. Store in a clean, dry area.

1. Clean entire lawn mower (See "CLEANING" in the Maintenance section of this manual).
2. Lubricate as shown in the Maintenance section of this manual.
3. Be sure that all nuts, bolts, screws, and pins are securely fastened. Inspect moving parts for damage, breakage and wear. Replace if necessary.
4. Touch up all rusted or chipped paint surfaces; sand lightly before painting.

HANDLE

You can fold your lawn mower handle for storage.

1. Squeeze the bottom ends of the lower handle toward each other until the lower handle clears the handle bracket, then move handle forward.
2. Loosen upper handle mounting bolts enough to allow upper handle to be folded back.

IMPORTANT: When folding the handle for storage or transportation, be sure to fold the handle as shown or you may damage the control cables.

- When setting up your handle from the storage position, the lower handle will automatically lock into the mowing position.

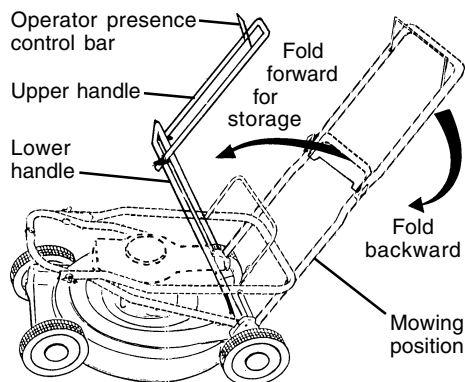
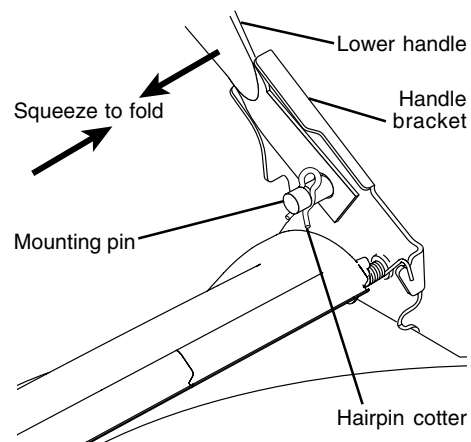

ENGINE

FUEL SYSTEM

IMPORTANT: It is important to prevent gum deposits from forming in essential fuel system parts such as carburetor, fuel filter, fuel hose or tank during storage. Also, experience indicates that alcohol blended fuels (called gasohol or using ethanol or methanol) can attract moisture which leads to separation and formation of acids during storage. Acidic gas can damage the fuel system of an engine while in storage.

1. Drain the fuel tank.
 2. Start the engine and let it run until the fuel lines and carburetor are empty.
- Never use engine or carburetor cleaner products in the fuel tank or permanent damage may occur.
 - Use fresh fuel next season.

NOTE: Fuel stabilizer is an acceptable alternative in minimizing the formation of fuel gum deposits during storage. Add stabilizer to gasoline in fuel tank or storage container. Always follow the mix ratio found on stabilizer container. Run engine at least 10 minutes after adding stabilizer to allow the stabilizer to reach the carburetor. Do not drain the gas tank and carburetor if using fuel stabilizer.

ENGINE OIL

Drain oil (with engine warm) and replace with clean engine oil. (See "ENGINE" in the Maintenance section of this manual).

GRASS CATCHER

- The grass catcher may be hosed with water, but must be dry when used.
- Check your grass catcher often for damage or deterioration. Through normal use it will wear. If catcher needs replacing, replace only with a manufacturer approved replacement catcher. Give the lawn mower model number when ordering.

ENGINE

LUBRICATION

Use only high quality detergent oil rated with API service classification SF-SJ. Select the oil's SAE viscosity grade according to your expected operating temperature.

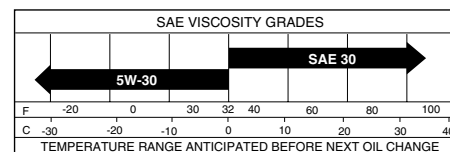

NOTE: Although multi-viscosity oils (5W30, 10W30 etc.) improve starting in cold weather, these multi-viscosity oils will result in increased oil consumption when used above 32°F. Check your engine oil level more frequently to avoid possible engine damage from running low on oil.

Change the oil after every 25 hours of operation or at least once a year if the lawn mower is not used for 25 hours in one year.

Check the crankcase oil level before starting the engine and after each five (5) hours of continuous use. Tighten oil plug securely each time you check the oil level.

TO CHANGE ENGINE OIL

- NOTE:** Before tipping lawn mower to drain oil, drain fuel tank by running engine until fuel tank is empty.
1. Disconnect spark plug wire from spark plug and place wire where it cannot come in contact with spark plug.
 2. Remove engine oil cap; lay aside on a clean surface.
 3. Tip lawn mower on its side as shown and drain oil into a suitable container. Rock lawn mower back and forth to remove any oil trapped inside of engine.
 4. Wipe off any spilled oil on lawn mower and on side of engine.

5. Fill engine with oil. (See "ADD OIL" in the Operation section of this manual.)
6. Reconnect spark plug wire to spark plug.

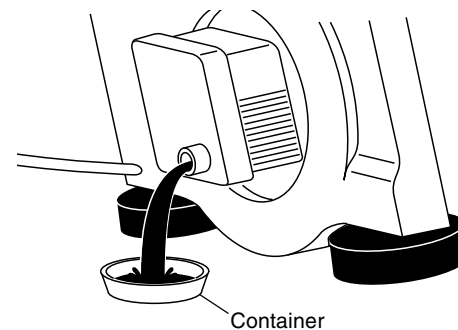

AIR FILTER

Your engine will not run properly and may be damaged by using a dirty air filter. Replace the air filter every year or after every 100 hours of operation, more often if you mow in very dusty, dirty conditions. Do not wash air filter.

TO CHANGE AIR FILTER

1. Remove the air filter by turning clockwise to the stop and pull away from collar.
2. Remove filter from inside of cover.
3. Clean the inside of the cover and the collar to remove any dirt accumulation.
4. Insert new filter into cover.
5. Put air filter cover and filter into collar aligning the tab with the slot.
6. Push in on cover and turn counter-clockwise to tighten.

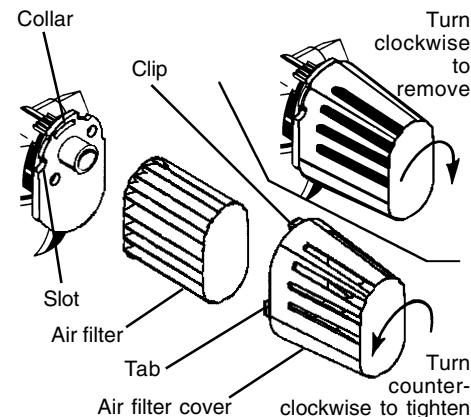

MUFFLER

Inspect and replace corroded muffler as it could create a fire hazard and/or damage.

SPARK PLUG

Replace spark plug at the beginning of each mowing season or after every 100 hours of operation, whichever ever occurs first. Spark plug type and gap setting are shown in "PRODUCT SPECIFICATIONS" section of this manual.

CLEANING

IMPORTANT: For best performance, keep mower housing free of built-up grass and trash. Clean the underside of your mower after each use.

CAUTION: Disconnect spark plug wire from spark plug and place wire where it cannot come in contact with the spark plug.

- Clean the underside of your lawn mower by scraping to remove build-up of grass and trash.
- Clean engine often to keep trash from accumulating. A clogged engine runs hotter and shortens engine life.
- Keep finished surfaces and wheels free of all gasoline, oil, etc.
- We do not recommend using a garden hose to clean lawn mower unless the electrical system, muffler, air filter and carburetor are covered to keep water out. Water in engine can result in shortened engine life.

CLEAN UNDER DRIVE COVER

Clean under drive cover at least twice a season. Scrape underside of cover with putty knife or similar tool to remove any build-up of trash or grass on underside of drive cover.

SERVICE AND ADJUSTMENTS

CAUTION: Before performing any service and adjustments:

1. Release control bar and stop engine.
2. Make sure the blade and all moving parts have completely stopped.
3. Disconnect spark plug wire from spark plug and place where it cannot come in contact with plug.

LAWN MOWER

TO ADJUST CUTTING HEIGHT

See "TO ADJUST CUTTING HEIGHT" in the Operation section of this manual.

REAR DEFLECTOR

The rear deflector, attached between the rear wheels of your lawn mower, is provided to minimize the possibility that objects will be thrown out the rear of the lawn mower into the operator's mowing position. If the rear deflector becomes damaged, it should be replaced.

TO REMOVE/REPLACE DRIVE BELT

1. Remove drive cover. Remove belt from gearcase pulley by pushing down on pulley and rolling belt off it.
2. Turn lawn mower on its side with air filter and carburetor up.
3. Remove blade.
4. Remove debris shield.
5. Remove belt from engine pulley on crankshaft.
6. Install new belt by reversing above steps.
7. Always use factory approved belt to assure fit and long life.

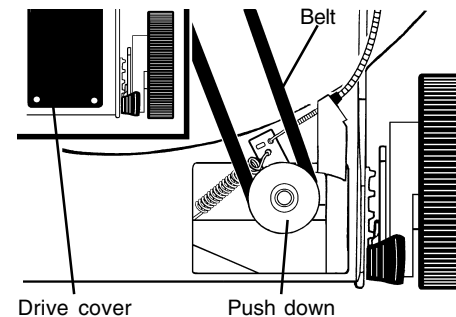

TO ADJUST HANDLE

The upper handle may be adjusted to four (4) different height positions.

1. Loosen both handle knobs only enough to allow the upper handle to pivot to the desired adjustment position.
2. Tighten both handle knobs securely.

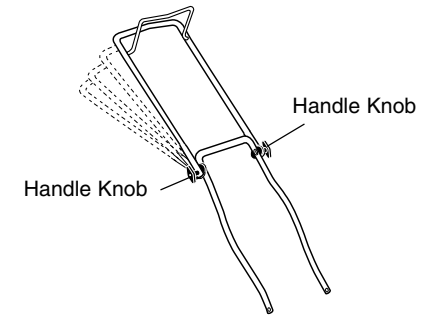

ENGINE

ENGINE SPEED

Your engine speed has been factory set. Do not attempt to increase engine speed or it may result in personal injury. If you believe that the engine is running too fast or too slow, take your lawn mower to a Sears or other qualified service center for repair and adjustment.

CARBURETOR

Your carburetor has a non-adjustable fixed main jet for mixture control. If your engine does not operate properly due to suspected carburetor problems, take your lawn mower to a Sears or other qualified service center for repair and/or adjustment.

IMPORTANT: Never tamper with the engine governor, which is factory set for proper engine speed. Overspeeding the engine above the factory high speed setting can be dangerous. If you think the engine-governed high speed needs adjusting, contact a Sears or other qualified service center, which has proper equipment and experience to make any necessary adjustments.