

Owner's Manual



ROTARY LAWN MOWER

5.5 Horsepower

21" Multi-Cut

Model No.

944.364542



CAUTION:

Read and follow all
Safety Rules and Instructions
before operating this equipment

Sears Canada, Inc., Toronto, Ontario M5B 2B8

TABLE OF CONTENTS

Warranty	2	Maintenance	11-14
Safety Rules	2-3	Service and Adjustments.....	14-15
Product Specifications	4	Storage	16-17
Assembly/Pre-Operation	4-5	Troubleshooting	18-19
Operation.....	6-10	Repair Parts.....	20-27
Maintenance Schedule	11	Sears Service	Back Cover

WARRANTY

LIMITED TWO YEAR WARRANTY ON CRAFTSMAN POWER MOWER

For two years from date of purchase Sears Canada, Inc. will repair or replace at Sears option free of charge parts which are defective as a result of material or workmanship.

COMMERCIAL OR RENTAL USE:

Warranty on Power Mower (Gas) will be ninety (90) days from date of purchase if used for commercial or rental purposes.

This Warranty does NOT cover:

- Pre-delivery set-up.
- Expendable items which become worn during normal use, such as rotary mower blades, blade adapters, belts, air cleaners and spark plug.
- Repairs necessary because of operator abuse or negligence, including bent crankshafts and the failure to maintain the equipment according to the instructions contained in the owner's manual.

Warranty service is available by returning the Craftsman Power Mower to the nearest Sears Service Centre/Department in Canada. This warranty applies only while this product is used in Canada.

This warranty is in addition to any statutory warranty and does not exclude or limit legal rights you may have but shall run concurrently with applicable provincial legislation. Furthermore, some provinces do NOT allow limitation on how long an implied warranty will last so the above limitations may not apply to you.

Sears Canada, Inc., Toronto, Ontario M5B 2B8

SAFETY RULES

IMPORTANT: This cutting machine is capable of amputating hands and feet and throwing objects. Failure to observe the following safety instructions could result in serious injury or death.

⚠ Look for this symbol to point out important safety precautions. It means **CAUTION!!! BECOME ALERT!!! YOUR SAFETY IS INVOLVED.**

⚠ CAUTION: Always disconnect spark plug wire and place wire where it cannot contact spark plug in order to prevent accidental starting when setting up, transporting, adjusting or making repairs.

⚠ CAUTION: Muffler and other engine parts become extremely hot during operation and remain hot after engine has stopped. To avoid severe burns on contact, stay away from these areas.



I. GENERAL OPERATION

- Read, understand, and follow all instructions on the machine and in the manual(s) before starting. Be thoroughly familiar with the controls and the proper use of the machine before starting.
- Do not put hands or feet near or under rotating parts. Keep clear of the discharge opening at all times.
- Only allow responsible individuals, who are familiar with the instructions, to operate the machine.
- Clear the area of objects such as rocks, toys, wire, bones, sticks, etc., which could be picked up and thrown by the blade.
- Be sure the area is clear of other people before mowing. Stop machine if anyone enters the area.

- Do not operate the mower when bare-foot or wearing open sandals. Always wear substantial foot wear.
- Do not pull mower backwards unless absolutely necessary. Always look down and behind before and while moving backwards.
- Do not operate the mower without proper guards, plates, grass catcher or other safety protective devices in place.
- See manufacturer's instructions for proper operation and installation of accessories. Only use accessories approved by the manufacturer.
- Stop the blade(s) when crossing gravel drives, walks, or roads.
- Stop the engine (motor) whenever you leave the equipment, before cleaning the mower or unclogging the chute.
- Shut the engine (motor) off and wait until the blade comes to complete stop before removing grass catcher.
- Mow only in daylight or good artificial light.
- Do not operate the machine while under the influence of alcohol or drugs.
- Never operate machine in wet grass. Always be sure of your footing: keep a firm hold on the handle and walk; never run.
- Disengage the self-propelled mechanism or drive clutch on mowers so equipped before starting the engine (motor).
- If the equipment should start to vibrate abnormally, stop the engine (motor) and check immediately for the cause. Vibration is generally a warning of trouble.
- Always wear safety goggles or safety glasses with side shields when operating mower.

II. SLOPE OPERATION

Slopes are a major factor related to slip and fall accidents which can result in severe injury. All slopes require extra caution. If you feel uneasy on a slope, do not mow it.

- Mow across the face of slopes: never up and down. Exercise extreme caution when changing direction on slopes.
- Remove obstacles such as rocks, tree limbs, etc.
- Watch for holes, ruts, or bumps. Tall grass can hide obstacles.

DO NOT:

- Do not trim near drop-offs, ditches or embankments. The operator could lose footing or balance.
- Do not trim excessively steep slopes.
- Do not mow on wet grass. Reduced footing could cause slipping.

III. CHILDREN

Tragic accidents can occur if the operator is not alert to the presence of children. Children are often attracted to the machine and the mowing activity. *Never* assume that children will remain where you last saw them.

- Keep children out of the trimming area and under the watchful care of another responsible adult.
- Be alert and turn machine off if children enter the area.
- Before and while walking backwards, look behind and *down* for small children.
- Never allow children to operate the machine.
- Use extra care when approaching blind corners, shrubs, trees, or other objects that may obscure vision.

IV. SERVICE

- Use extra care in handling gasoline and other fuels. They are flammable and vapors are explosive.
 - Use only an approved container.
 - Never remove gas cap or add fuel with the engine running. Allow engine to cool before refueling. Do not smoke.
 - Never refuel the machine indoors.
 - Never store the machine or fuel container inside where there is an open flame, such as a water heater.
- Never run a machine inside a closed area.
- Never make adjustments or repairs with the engine (motor) running. Disconnect the spark plug wire, and keep the wire away from the plug to prevent accidental starting.
- Keep nuts and bolts, especially blade attachment bolts, tight and keep equipment in good condition.
- Never tamper with safety devices. Check their proper operation regularly.
- Keep machine free of grass, leaves, or other debris build-up. Clean oil or fuel spillage. Allow machine to cool before storing.
- Stop and inspect the equipment if you strike an object. Repair, if necessary, before restarting.
- Never attempt to make wheel height adjustments while the engine (motor) is running.
- Grass catcher components are subject to wear, damage, and deterioration, which could expose moving parts or allow objects to be thrown. Frequently check components and replace with manufacturer's recommended parts, when necessary.
- Mower blades are sharp and can cut. Wrap the blade(s) or wear gloves, and use extra caution when servicing them.
- Do not change the engine governor setting or overspeed the engine.

PRODUCT SPECIFICATIONS

Serial Number:	
Date of Purchase:	
Gasoline Capacity / Type:	0,94 Litres (Unleaded Regular)
Oil Capacity:	0,5 Litres
Oil Type (API SG–SL):	SAE 30 (above 0°C/32°F) or SAE 10W-30
Spark Plug (Gap: 0,76 mm)	NGK BPR6ES
Valve Clearance (± 0.04 mm):	Intake: 0.015 mm; Exhaust: 0.020 mm
Blade Bolt Torque:	35-40 ft. lbs. (47-54 N-m)
<ul style="list-style-type: none">• The model and serial numbers will be found on a decal on the rear of the lawn mower housing. Record both serial number and date of purchase in space provided above.	

ASSEMBLY / PRE-OPERATION

Read these instructions and this manual in its entirety before you attempt to assemble or operate your new lawn mower.

IMPORTANT: This lawn mower is shipped WITHOUT OIL OR GASOLINE in the engine.

Your new lawn mower has been assembled at the factory with the exception of those parts left unassembled for shipping purposes. All parts such as nuts, washers, bolts, etc., necessary to complete the assembly have been placed in the parts bag. To ensure safe and proper operation of your lawn mower, all parts and hardware you assemble must be tightened securely. Use the correct tools as necessary to ensure proper tightness.

TO REMOVE MOWER FROM CARTON

1. Remove loose parts included with mower.
2. Cut down two end corners of carton and lay end panel down flat.
3. Remove all packing materials except padding between upper and lower handle and padding holding operator presence control bar to upper handle.
4. Roll mower out of carton and check carton thoroughly for additional loose parts.

HOW TO SET UP YOUR MOWER

TO UNFOLD HANDLE

IMPORTANT: Unfold handle carefully so as not to pinch or damage control cables.

1. Raise lower handle section to operating position and squeeze the bottom ends of lower handle towards each other until the pin in handle can be inserted into one of the three height adjustment holes.
2. Remove protective padding, raise upper handle section into place on lower handle and tighten both handle knobs.
3. Remove any packing material from around control bar.

Your lawn mower handle can be adjusted for your mowing comfort. Refer to "ADJUST HANDLE" in the Service and Adjustments section of this manual.

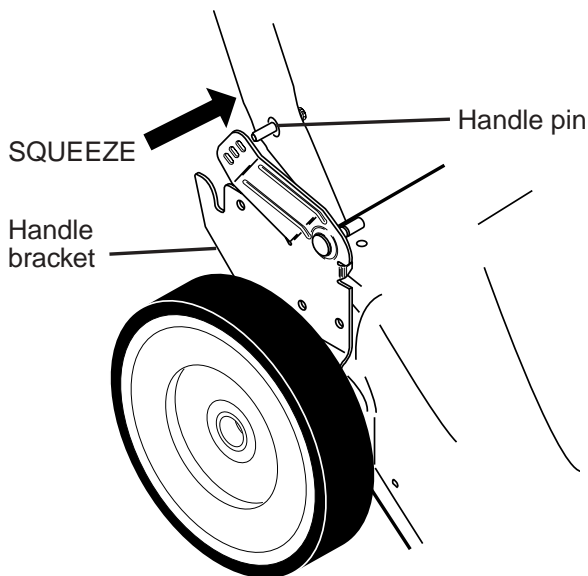
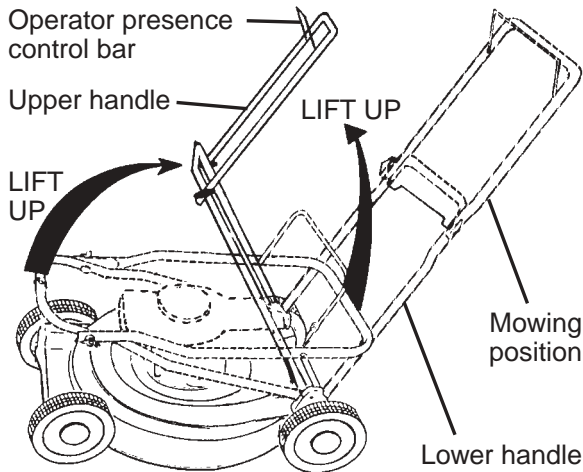

TO ASSEMBLE GRASS CATCHER

1. Put grass catcher frame into grass bag with rigid part of bag on the bottom. Make sure the frame handle is outside of the bag top.

2. Slip vinyl bindings over frame.

NOTE: If vinyl bindings are too stiff, hold them in warm water for a few minutes. If bag gets wet, let it dry before using.

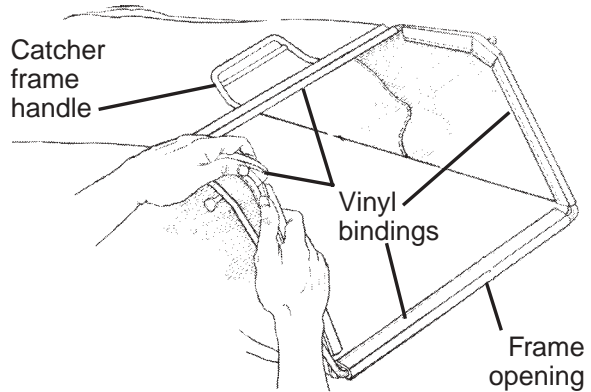

TO INSTALL ATTACHMENTS

Your lawn mower was shipped ready to be used as a mulcher. To convert to bagging, see "TO CONVERT MOWER" in the Operation section of this manual.

OPERATION

KNOW YOUR LAWN MOWER

READ THIS OWNER'S MANUAL AND ALL SAFETY RULES BEFORE OPERATING YOUR LAWN MOWER. Compare the illustrations with your lawn mower to familiarize yourself with the location of various controls and adjustments. Save this manual for future reference.

These symbols may appear on your lawn mower or in literature supplied with the product. Learn and understand their meaning.

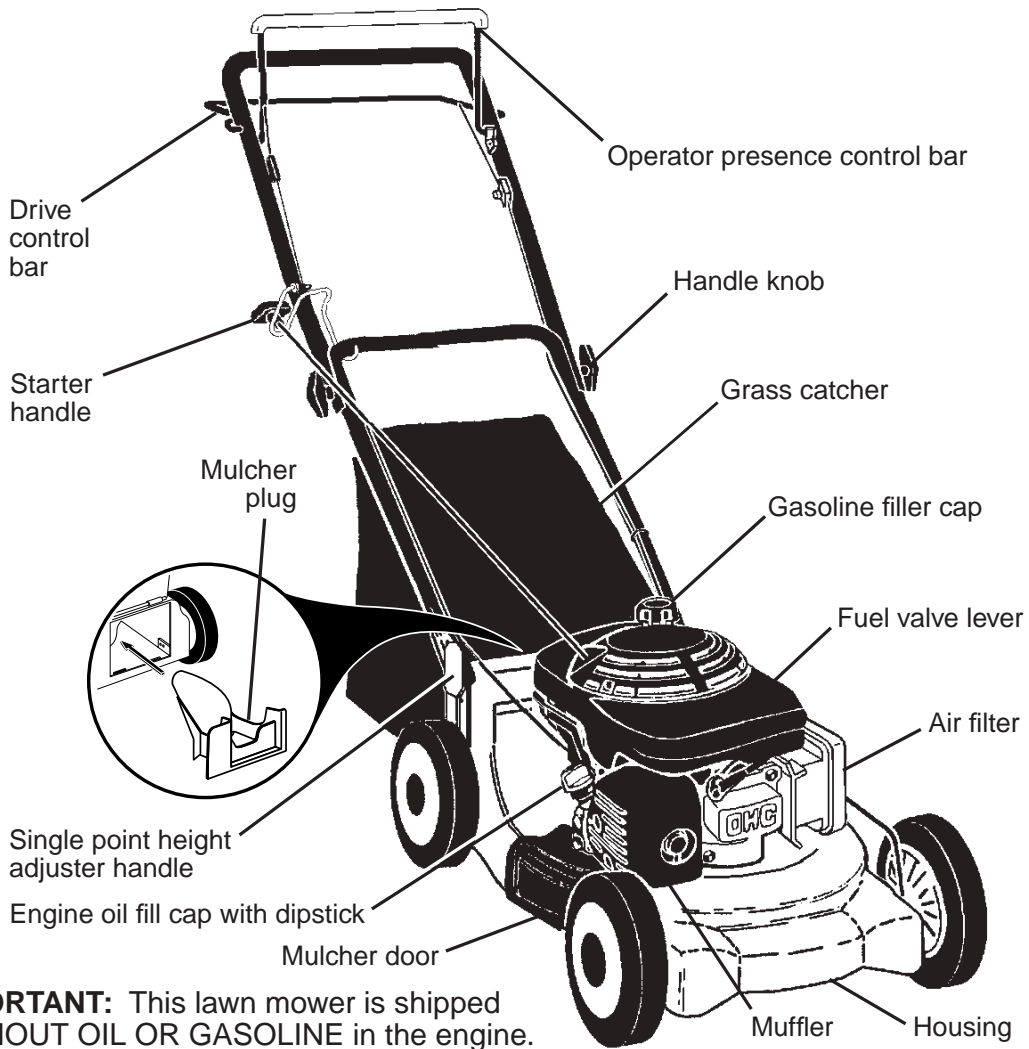
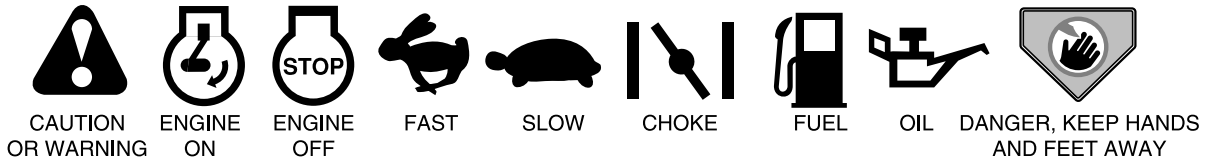

IMPORTANT: This lawn mower is shipped WITHOUT OIL OR GASOLINE in the engine.

MEETS CPSC SAFETY REQUIREMENTS

Sears rotary walk-behind power lawn mowers conform to the safety standards of the American National Standards Institute and the U.S. Consumer Product Safety Commission. The blade turns when the engine is running.

Operator presence control bar – must be held down to the handle to start the engine. Release to stop the engine.
Drive control bar – used to engage power-propelled forward motion of mower.
Single point height adjuster – used to adjust cutting height of lawn mower.

Starter handle – used for starting engine.
Mulcher door – allows conversion to discharging or bagging operation.
Mulcher plug – located at the rear discharge opening. Must be removed when converting to bagging operation.



The operation of any lawn mower can result in foreign objects thrown into the eyes, which can result in severe eye damage. Always wear safety glasses or eye shields while operating your lawn mower or performing any adjustments or repairs. We recommend standard safety glasses or a wide vision safety mask worn over spectacles.

HOW TO USE YOUR LAWN MOWER ENGINE SPEED

The engine speed was set at the factory for optimum performance. Speed is not adjustable.

ENGINE ZONE CONTROL

CAUTION: Federal regulations require an engine control to be installed on this lawn mower in order to minimize the risk of blade contact injury. Do not under any circumstances attempt to defeat the function of the operator control. The blade turns when the engine is running.

- Your lawn mower is equipped with an operator presence control bar which requires the operator to be positioned behind the lawn mower handle to start and operate the lawn mower.

DRIVE CONTROL

- Self-propelling is controlled by holding the operator presence control bar down to the handle and pulling the drive control bar up to the handle. The closer to the handle the bar is pulled, the faster the unit will travel.
- Forward motion will stop when either the operator presence control bar or drive control bar are released. To stop forward motion without stopping engine, release the drive control bar only. Hold operator presence control bar down against handle to continue mowing without self-propelling.

NOTE: If after releasing the drive control the mower will not roll backwards, push the mower forward slightly to disengage drive wheels.

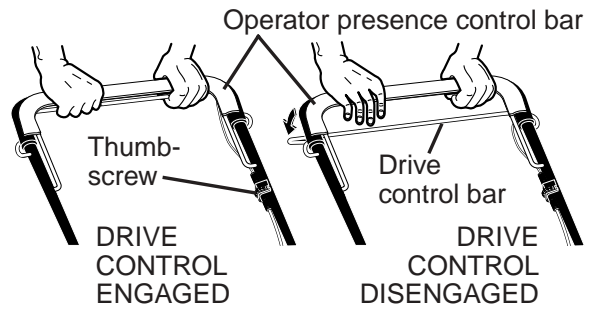

DRIVE CONTROL ADJUSTMENT

Over time, the drive control system may become "loose", resulting in decreased speed. There is a thumbscrew on the underside of the drive control housing to increase tension on the drive cable. Proceed as follows:

1. Turn unit off and disconnect spark plug wire from spark plug.
2. Rotate thumbscrew counter-clockwise to tighten the drive cable.
3. Operate mower to test drive speed.
4. If condition fails to improve after the above steps (forward speed remains the same), your drive belt is worn and should be replaced.

NOTE: If mower begins to "creep" forward, the drive cable is too tight. Rotate thumbscrew clockwise to loosen drive cable.

TO ADJUST CUTTING HEIGHT

All four wheels are adjusted by a single lever.

- Pull adjuster lever toward wheel. To raise mower, move lever forward to desired position. To lower mower, move the lever toward the rear.

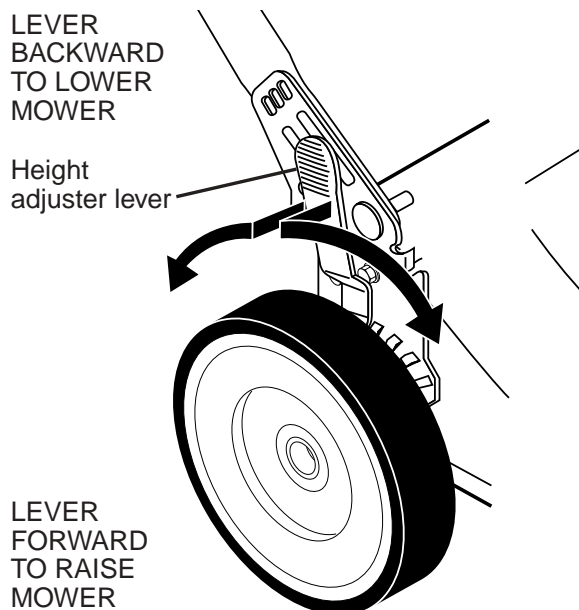

TO ATTACH GRASS CATCHER

1. Lift the rear door of the lawn mower and place the grass catcher frame side hooks onto the door pivot pins.
2. The grass catcher is secured to the lawn mower housing when the rear door is lowered onto the grass catcher frame.

⚠CAUTION: Do not run your lawn mower without mulcher plug, clipping deflector or approved grass catcher in place. Never attempt to operate the lawn mower with the rear door removed or propped open.

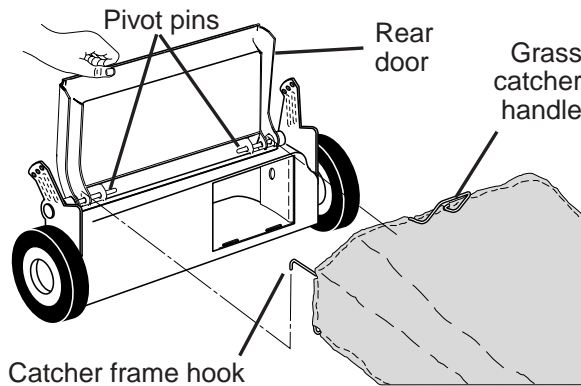

TO EMPTY GRASS CATCHER

1. Lift up on grass catcher using the frame handle.
2. Remove grass catcher with clippings from under lawn mower handle.
3. Empty clippings from bag using both frame handle and bag handle.

NOTE: Do not drag the bag when emptying; it will cause unnecessary wear.

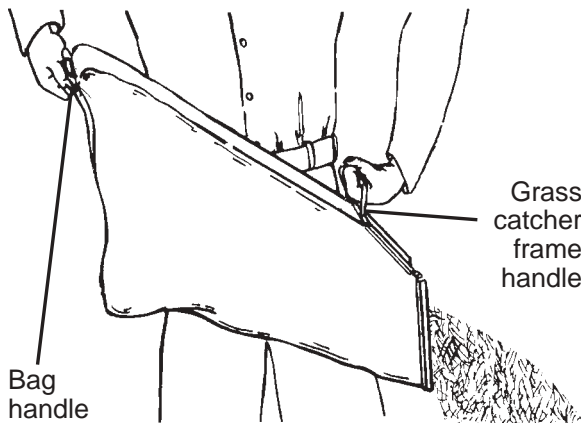

TO CONVERT MOWER

Your lawn mower was shipped ready to be used as a mulcher. To convert to bagging or discharging:

REAR BAGGING

- Open rear door and remove mulcher plug. Store mulcher plug in a safe place.
- You can now install the grass catcher or optional clipping deflector.
- To convert to mulching or discharging operation, install mulcher plug into rear discharge opening of mower.

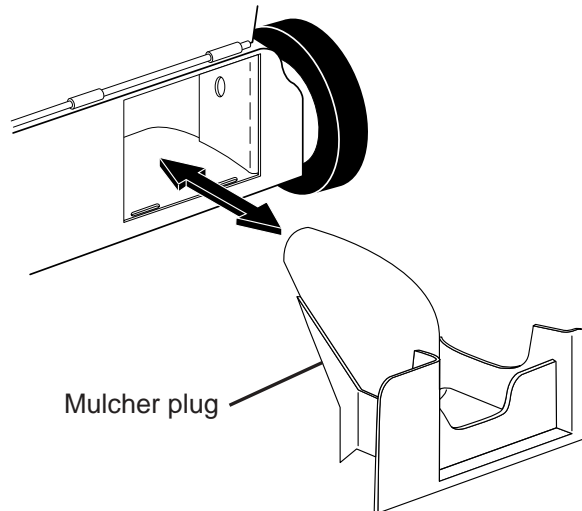

SIDE DISCHARGING

- Mulcher plug must be installed into rear discharge opening of mower.
- Open mulcher door and install discharge deflector under door as shown.
- Mower is now ready for discharging operation.
- To convert to mulching or bagging operation, discharge deflector must be removed and mulcher door closed.

SIMPLE STEPS TO REMEMBER WHEN CONVERTING YOUR LAWN MOWER

FOR MULCHING -

1. Rear mulcher plug installed.
2. Mulcher door closed.

FOR REAR BAGGING -

1. Rear mulcher plug removed.
2. Grass catcher installed.
3. Mulcher door closed.

FOR SIDE DISCHARGING -

1. Rear mulcher plug installed.
2. Discharge deflector installed.

CAUTION: Do not run your lawn mower without mulcher plug, clipping deflector or approved grass catcher in place. Never attempt to operate the lawn mower with the rear door removed or propped open.

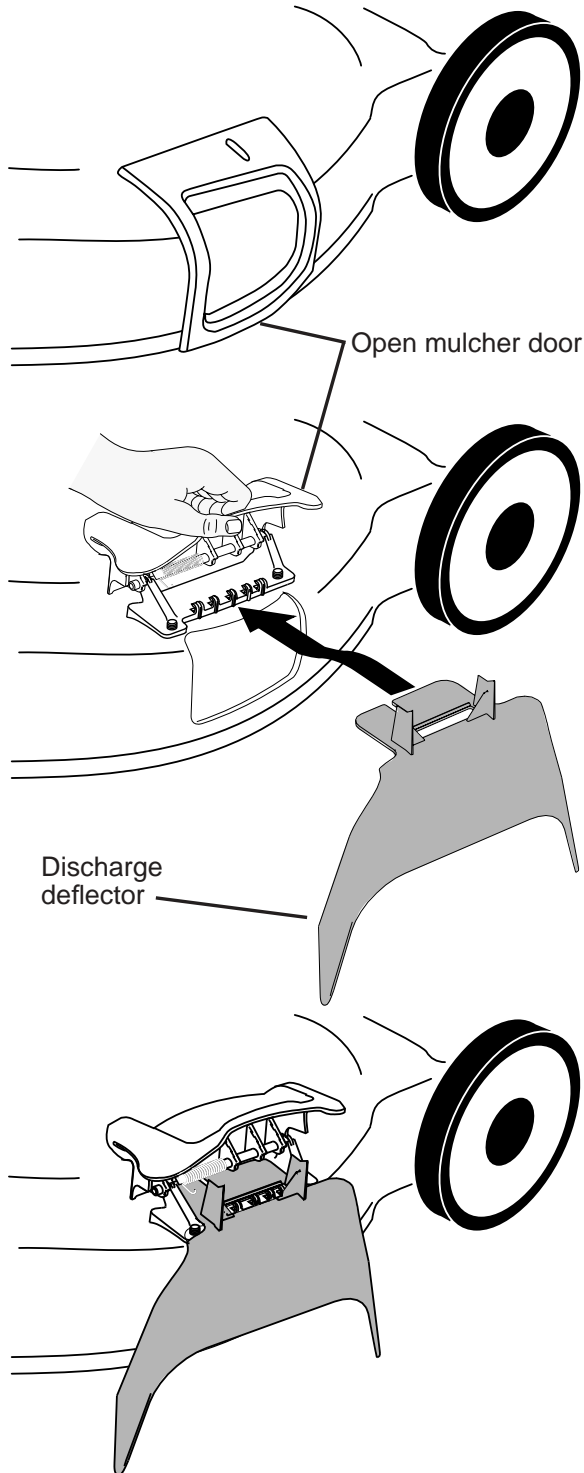

BEFORE STARTING ENGINE

ADD OIL

Your lawnmower is shipped without oil in the engine. For type and grade of oil to use, see "ENGINE" in the Maintenance section of this manual.

CAUTION: DO NOT overfill engine with oil, or it will smoke on startup.

1. Be sure lawnmower is level.
2. Remove oil fill cap/dipstick from oil fill spout.
3. You receive a container of oil with the unit. Slowly pour the entire container down the oil fill spout into the engine.
4. Insert and tighten oil fill cap/dipstick.

IMPORTANT:

- Check oil level before each use. Add oil if needed. Fill to full line on dipstick.
- Change the oil after every 25 hours of operation or each season. You may need to change the oil more often under dusty, dirty conditions. See "TO CHANGE ENGINE OIL" in the Maintenance section of this manual.

ADD GASOLINE

- Fill fuel tank to bottom of tank filler neck. Do not overfill. Use fresh, clean, regular unleaded gasoline with a minimum of 87 octane. Do not mix oil with gasoline. Purchase fuel in quantities that can be used within 30 days to assure fuel freshness.

CAUTION: Wipe off any spilled oil or fuel. Do not store, spill or use gasoline near an open flame.

CAUTION: Alcohol blended fuels (called gasohol or using ethanol or methanol) can attract moisture which leads to separation and formation of acids during storage. Acidic gas can damage the fuel system of an engine while in storage. To avoid engine problems, the fuel system should be emptied before storage of 30 days or longer. Empty the gas tank, start the engine and let it run until the fuel lines and carburetor are empty. Use fresh fuel next season. See Storage Instructions for additional information. Never use engine or carburetor cleaner products in the fuel tank or permanent damage may occur.

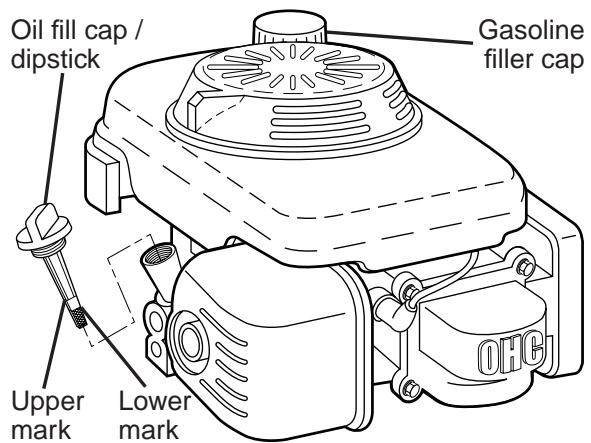

TO STOP ENGINE

- To stop engine, release operator presence control bar. Wait until blade and all moving parts have stopped and turn fuel valve to OFF position if you do not intend to restart the engine soon.

TO START ENGINE

NOTE: Due to protective coatings on the engine, a small amount of smoke may be present during the initial use of the product and should be considered normal.

1. Be sure fuel valve is in the ON position.
2. Move choke lever to ON (|↘|) position.
3. Hold operator presence control bar down to the handle and pull starter handle quickly. Do not allow starter rope to snap back.

NOTE: The choke lever automatically begins moving to the OFF position when operator presence control bar is held down to handle.

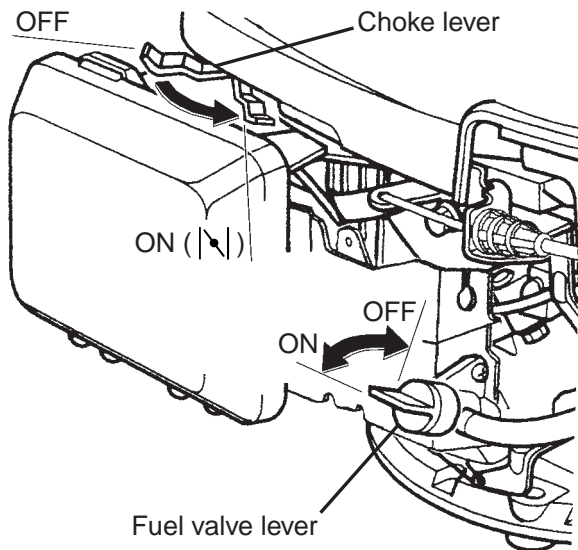

MOWING TIPS

- Under certain conditions, such as very tall grass, it may be necessary to raise the height of cut to reduce pushing effort and to keep from overloading the engine and leaving clumps of grass clippings. It may also be necessary to reduce ground speed and/or run the lawn mower over the area a second time.
- For extremely heavy cutting, reduce the width of cut by overlapping previously cut path and mow slowly.
- For better grass bagging and most cutting conditions, the engine speed should be set in the FAST position.

- Pores in cloth grass catchers can become filled with dirt and dust with use and catchers will collect less grass. To prevent this, regularly hose catcher off with water and let dry before using.
- Keep top of engine around starter clear and clean of grass clippings and chaff. This will help engine air flow and extend engine life.

MULCHING MOWING TIPS

IMPORTANT: For best performance, keep mower housing free of built-up grass and trash. See "CLEANING" in the Maintenance section of this manual.

- The special mulching blade will recut the grass clippings many times and reduce them in size so that as they fall onto the lawn they will disperse into the grass and not be noticed. Also, the mulched grass will biodegrade quickly to provide nutrients for the lawn. Always mulch with your highest engine (blade) speed as this will provide the best recutting action of the blades.
- Avoid cutting your lawn when it is wet. Wet grass tends to form clumps and interferes with the mulching action. The best time to mow your lawn is the early afternoon. At this time the grass has dried, yet the newly cut area will not be exposed to direct sunlight.
- For best results, adjust the lawn mower cutting height so that the lawn mower cuts off only the top one-third of the grass blades. If the lawn is overgrown it will be necessary to raise the height of cut to reduce pushing effort and to keep from overloading the engine and leaving clumps of mulched grass. For extremely heavy grass, reduce your width of cut by overlapping previously cut path and mow slowly.



- Certain types of grass and grass conditions may require that an area be mulched a second time to completely hide the clippings. When doing a second cut, mow across (perpendicular) to the first cut path.
- Change your cutting pattern from week to week. Mow north to south one week then change to east to west the next week. This will help prevent matting and graining of the lawn.

MAINTENANCE

MAINTENANCE SCHEDULE		BEFORE EACH USE	AFTER EACH USE	EVERY 10 HOURS	EVERY 25 HOURS OR SEASON	EVERY 100 HOURS	BEFORE STORAGE
LAWN MOWER	Check for Loose Fasteners	✓					✓
	Clean / Inspect Grass Catcher *	✓	✓				✓
	Check Tires	✓					
	Check Drive Wheels ***	✓					
	Clean Lawn Mower ****		✓				✓
	Clean under Drive Cover ***			✓			
	Check Drive Belt / Pulleys ***				✓		
	Check / Sharpen / Replace Blade				✓ ₃		
ENGINE	Lubrication				✓		
	Clean and Recharge Battery **				✓		✓ ₄
	Check Engine Oil level	✓ ₅					
	Change Engine Oil				✓ _{1,2}		
	Clean Air Filter				✓ ₂		
	Inspect Muffler				✓		
	Replace Spark Plug					✓	
	Replace Air Filter Paper Cartridge					✓ ₂	
Empty fuel system or add Stabilizer						✓	

- * (if so equipped)
- ** Electric-Start mowers
- *** Power-Propelled mowers
- **** Use a scraper to clean under deck
- 1 - Change more often if operating under a heavy load or in high outdoor temperatures.
- 2 - Service more often if operating in dirty or dusty conditions.
- 3 - Replace blades more often when mowing in sandy soil.
- 4 - Charge 48 hours at end of season.
- 5 - And after each 5 hours of use.

GENERAL RECOMMENDATIONS

The warranty on this lawn mower does not cover items that have been subjected to operator abuse or negligence. To receive full value from the warranty, operator must maintain unit as instructed in this manual.

Some adjustments will need to be made periodically to properly maintain your unit.

At least once a season, check to see if you should make any of the adjustments described in the Service and Adjustments section of this manual.

- At least once a year, replace the spark plug, clean or replace air filter element and check blade for wear. A new spark plug and clean/new air filter element assure proper air-fuel mixture and help your engine run better and last longer.
- Follow the maintenance schedule in this manual.

BEFORE EACH USE

- Check engine oil level.
- Check for loose fasteners.

LUBRICATION

Keep unit well lubricated (See "LUBRICATION CHART").

LUBRICATION CHART

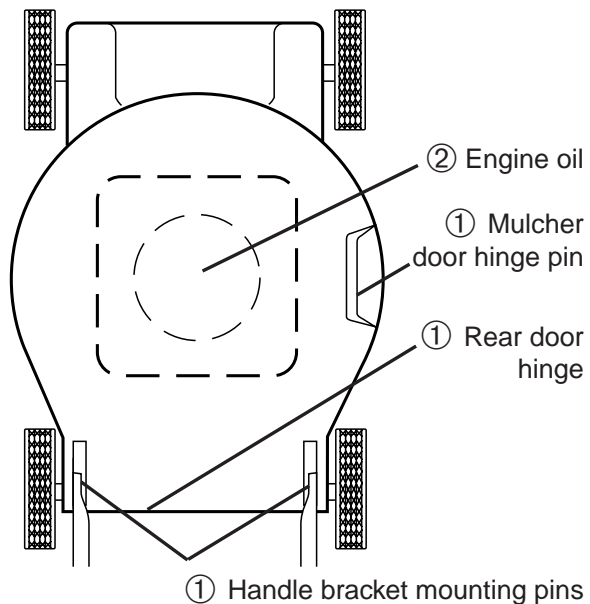

- ① Spray lubricant
- ② See "ENGINE" in Maintenance section.

IMPORTANT: Do not oil or grease plastic wheel bearings. Viscous lubricants will attract dust and dirt that will shorten the life of the self-lubricating bearings. If you feel they must be lubricated, use only a dry, powdered graphite type lubricant sparingly.

LAWN MOWER

Always observe safety rules when performing any maintenance.

TIRES

- Keep tires free of gasoline, oil, or insect control chemicals which can harm rubber.
- Avoid stumps, stones, deep ruts, sharp objects and other hazards that may cause tire damage.

DRIVE WHEELS

Check rear drive wheels each time you mow to be sure they move freely. The wheels not turning freely means trash, grass cuttings, etc., may be inside the drive wheel and dust cover area and must be cleaned out to free drive wheels. If necessary to clean the drive wheels, check both rear wheels.

BLADE CARE

For best results, blade must be kept sharp. Replace a bent or damaged blade.

TO REMOVE BLADE

1. Disconnect spark plug wire from spark plug and place wire where it cannot come in contact with plug.
2. Turn lawn mower on its side. Make sure air filter and carburetor are up.
3. Use a wood block between blade and mower housing to prevent blade from turning when removing blade bolt.

NOTE: Protect your hands with gloves and/or wrap blade with heavy cloth.

4. Remove blade bolt by turning counter-clockwise.
5. Remove blade and attaching hardware (bolt, lock washer, hardened washer).

NOTE: Remove the blade adapter and check the key inside hub of blade adapter. The key must be in good condition to work properly. Replace adapter if damaged.

TO REPLACE BLADE

1. Position the blade adapter on the engine crankshaft. Be sure key in adapter and crankshaft keyway are aligned.
 2. Position blade on the blade adapter aligning the two (2) holes in the blade with the raised lugs on the adapter.
 3. Be sure the trailing edge of blade (opposite sharp edge) is up toward the engine.
 4. Install the blade bolt with the lock washer and hardened washer into blade adapter and crankshaft.
 5. Use block of wood between blade and lawn mower housing and tighten the blade bolt, turning clockwise.
- The recommended tightening torque is 35-40 ft. lbs. / 47-54 N-m.

IMPORTANT: Blade bolt is heat treated. If bolt needs replacing, replace only with approved bolt shown in the Repair Parts section of this manual.

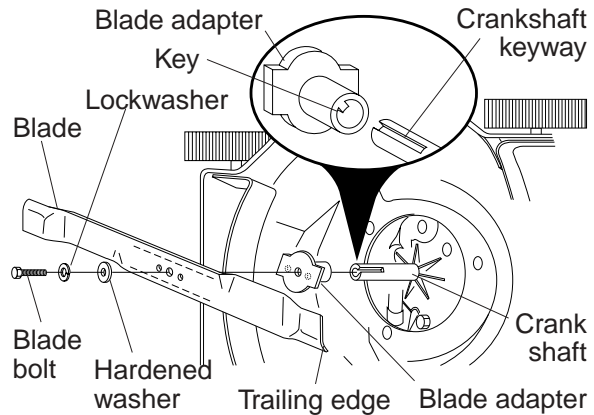

TO SHARPEN BLADE

NOTE: We do not recommend sharpening blade - but if you do, be sure the blade is balanced. Care should be taken to keep the blade balanced. An unbalanced blade will cause eventual damage to lawn mower or engine.

- The blade can be sharpened with a file or on a grinding wheel. Do not attempt to sharpen while on the mower.
- To check blade balance, drive a nail into a beam or wall. Leave about one inch of the straight nail exposed. Place center hole of blade over the head of the nail. If blade is balanced, it should remain in a horizontal position. If either end of the blade moves downward, sharpen the heavy end until the blade is balanced.

GRASS CATCHER

- The grass catcher may be hosed with water, but must be dry when used.
- Check your grass catcher often for damage or deterioration. Through normal use it will wear. If catcher needs replacing, replace only with approved replacement catcher shown in the Repair Parts section of this manual. Give the lawn mower model number when ordering.

GEAR CASE

- To keep your drive system working properly, the gear case and area around the drive should be kept clean and free of trash build-up. Clean under the drive cover twice a season.
- The gear case is filled with lubricant to the proper level at the factory. The only time the lubricant needs attention is if service has been performed on the gear case.
- If lubricant is required, use only Texaco Starplex Premium 1 Grease, Part No. 750369. Do not substitute.

ENGINE

Maintenance, repair, or replacement of the emission control devices and systems, which are being done at the customer's expense, may be performed by any non-road engine repair establishment or individual. Warranty repairs must be performed by an authorized engine manufacturer's service outlet.

LUBRICATION

Use only high quality detergent oil rated with API service classification SG-SL. Select the oil's SAE viscosity grade according to your expected operating temperature.

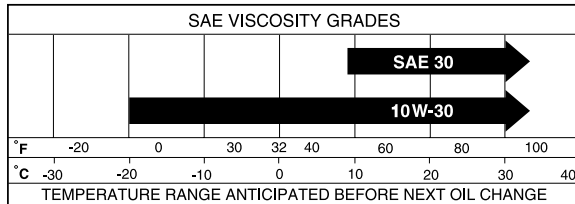

NOTE: Multi-viscosity oils (5W30, 10W30 etc.) improve starting in cold weather, and you should check your engine oil level frequently to avoid possible engine damage from running low on oil.

Change the oil after every 25 hours of operation or at least once a year if the lawn mower is not used for 25 hours in one year. Check the crankcase oil level before starting the engine and after each five (5) hours of continuous use. Tighten oil plug securely each time you check the oil level.

TO CHANGE ENGINE OIL

NOTE: Before tipping lawn mower to drain oil, empty fuel tank by running engine until fuel tank is empty.

1. Disconnect spark plug wire from spark plug and place wire where it cannot come in contact with plug.
2. Remove oil fill cap/dipstick; lay aside on a clean surface.
3. Tip lawn mower on its side as shown and drain oil into a suitable container. Rock lawn mower back and forth to remove any oil trapped inside of engine.

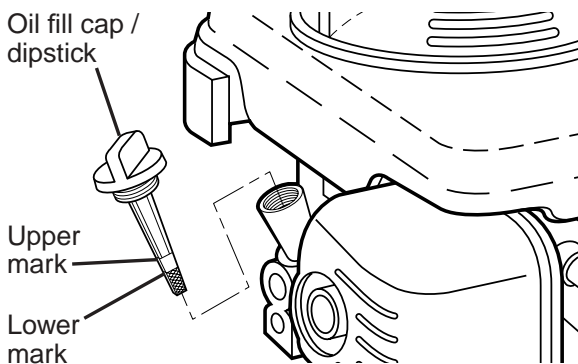

4. Wipe off any spilled oil from lawn mower or side of engine.
5. Fill engine with oil. Slowly pour oil down the oil fill spout into the engine.
6. Wait one minute to allow oil to settle. Use gauge on oil fill cap/dipstick for checking level. Insert dipstick into the tube and rest the oil fill cap on the tube. DO NOT thread the cap into the tube when taking reading.
7. Continue adding small amounts of oil and rechecking the dipstick until it reads full. DO NOT overfill, or engine will smoke on startup.
8. Always be sure to retighten oil fill cap/dipstick before starting engine.
9. Reconnect spark plug wire to spark plug.

AIR FILTER

Your engine will not run properly and may be damaged by using a dirty air filter. Replace the air filter every 100 hours of operation or every season, whichever occurs first. Service air cleaner more often under dusty conditions.

TO CLEAN AIR FILTER

1. Remove cover.
2. Carefully remove cartridge.
3. Clean by gently tapping on a flat surface. If very dirty, replace cartridge.

CAUTION: Petroleum solvents, such as kerosene, are not to be used to clean cartridge. They may cause deterioration of the cartridge. Do not oil cartridge. Do not use pressurized air to clean or dry cartridge.

4. Install cartridge, then replace cover.

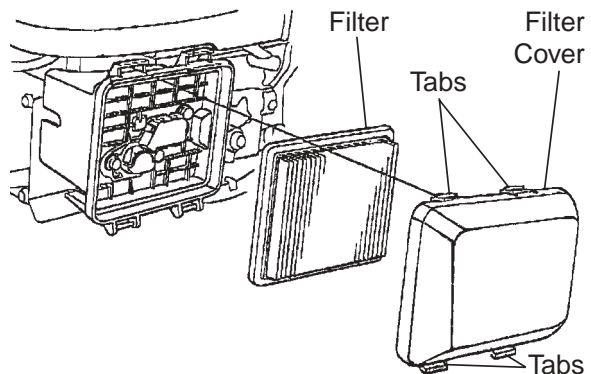

MUFFLER

Inspect and replace corroded muffler as it could create a fire hazard and/or damage.

SPARK PLUG

Replace spark plug at the beginning of each mowing season or after every 100 hours of operation, whichever occurs first. Spark plug type and gap setting are shown in the "PRODUCT SPECIFICATIONS" section of this manual.

CLEANING

IMPORTANT: For best performance, keep mower housing free of built-up grass and trash. Clean the underside of your mower after each use.

CAUTION: Disconnect spark plug wire from spark plug and place wire where it cannot come in contact with plug.

- Clean underside of mower by scraping to remove build-up of grass and trash.
- Clean engine often to keep trash from accumulating. A clogged engine runs hotter and shortens engine life.

- Keep finished surfaces and wheels free of all gasoline, oil, etc.
- We do not recommend using a garden hose to clean lawn mower unless the electrical system, muffler, air filter and carburetor are covered to keep water out. Water in engine can result in shortened engine life.

CLEAN UNDER DRIVE COVER

Clean under drive cover at least twice a season. Scrape underside of cover with putty knife or similar tool to remove any build-up of trash or grass on underside of drive cover.

SERVICE AND ADJUSTMENTS

WARNING: To avoid serious injury, before performing any service or adjustments:

1. Release control bar and stop engine.
2. Make sure the blade and all moving parts have completely stopped.
3. Disconnect spark plug wire from spark plug and place wire where it cannot come in contact with plug.

LAWN MOWER

TO ADJUST CUTTING HEIGHT

See "TO ADJUST CUTTING HEIGHT" in the Operation section of this manual.

REAR DEFLECTOR

The rear deflector, attached between the rear wheels of your mower, is provided to minimize the possibility that objects will be thrown out of the rear of the mower into the operator mowing position. If the deflector becomes damaged, it should be replaced.

TO REMOVE DRIVE BELT

1. Disconnect spark plug wire from spark plug and place wire where it cannot come in contact with plug.
2. Remove screws retaining drive cover (not shown); and remove drive cover from lawn mower housing.
3. Remove drive cable from anchor, then detach spring from idler arm assembly.

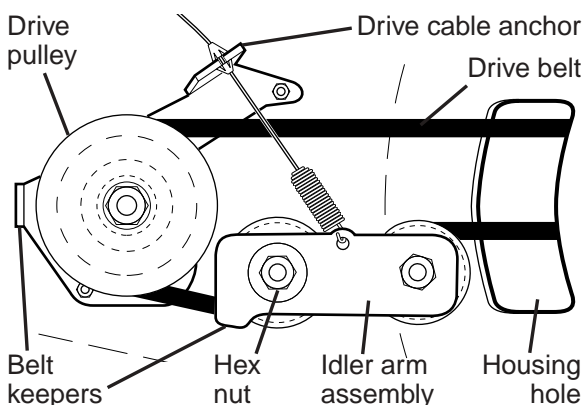

4. Remove idler arm assembly from housing by removing hex nut; then remove drive belt from drive pulley, belt keepers and idler arm assembly.
5. Turn lawn mower on its side. Make sure air filter and carburetor are up.
6. Use a wood block between blade and mower housing to prevent blade from turning when removing blade bolt.

NOTE: Protect your hands with gloves and/or wrap blade with heavy cloth.

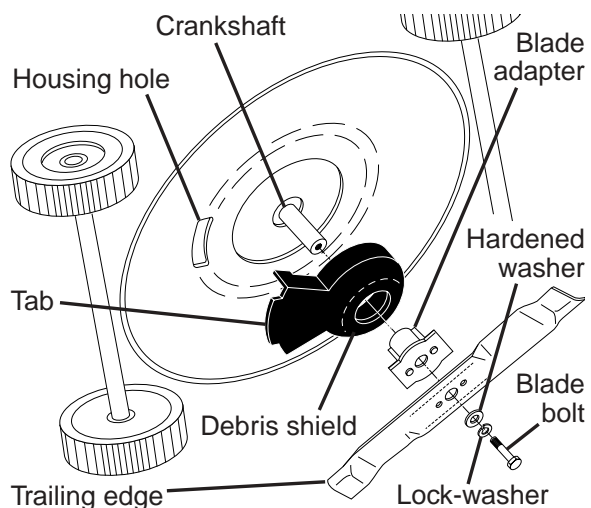

7. Remove blade bolt.
8. Remove blade, attaching hardware (bolt, lock washer and hardened washer), blade adapter and debris shield. Note that the debris shield has a tab which fits into the housing hole.
9. Remove drive belt from engine pulley; discard old belt.

TO REPLACE DRIVE BELT

1. Place new drive belt on engine pulley.
2. Route the other end of the new drive belt through hole in housing.
3. Return mower to upright position.
4. Install new drive belt into idler arm assembly, then around the drive pulley. Be sure belt is inside of belt keepers.
5. Reattach idler arm assembly with hex nut previously removed.
6. Turn lawn mower on its side. Make sure air filter and carburetor are up.
7. Reattach debris shield to housing with tab of debris shield in housing hole.
8. Position blade on the blade adapter aligning the two (2) holes in the blade with the raised lugs on the adapter.
9. Be sure the trailing edge of blade (opposite sharp edge) is up toward the engine as shown.
10. Install the blade bolt with the lock washer and hardened washer into blade adapter and crankshaft.
11. Use block of wood between blade and lawn mower housing and tighten the blade bolt, turning clockwise.
 - The recommended tightening torque is 35-40 ft. lbs.

TO ADJUST HANDLE

The handle on your lawn mower has three (3) height positions - adjust to height that suits you.

- Squeeze the bottom ends of lower handle towards each other until the pin in handle can be inserted into one of the three height adjustment holes.

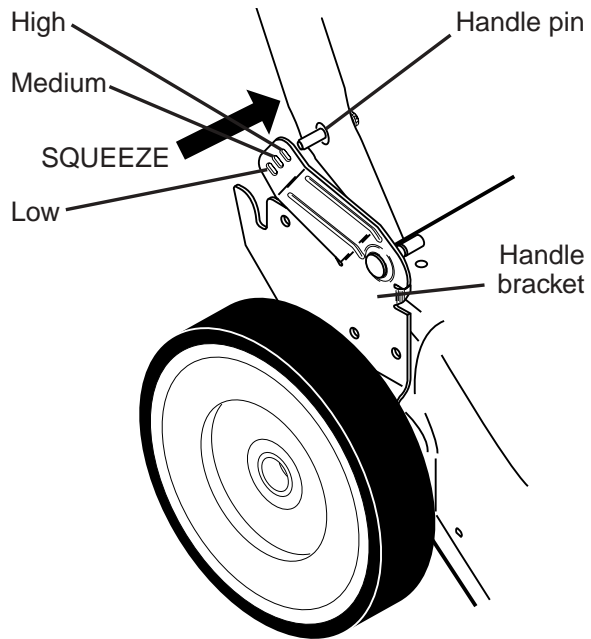

ENGINE

Maintenance, repair, or replacement of the emission control devices and systems, which are being done at the customer's expense, may be performed by any non-road engine repair establishment or individual. Warranty repairs must be performed by an authorized engine manufacturer's service outlet.

ENGINE SPEED

Your engine speed has been factory set. Do not attempt to increase engine speed or it may result in personal injury. If you believe that the engine is running too fast or too slow, take your lawn mower to a Sears or other qualified service center for repair and adjustment.

CARBURETOR

Your carburetor is not adjustable. If your engine does not operate properly due to suspected carburetor problems, take your lawn mower to a Sears or other qualified service center for repair or adjustment.

IMPORTANT: Never tamper with the engine governor, which is factory set for proper engine speed. Overspeeding the engine above the factory high speed setting can be dangerous. If you think the engine-governed high speed needs adjusting, contact a Sears or other qualified service center, which has proper equipment and experience to make any necessary adjustments.

STORAGE

Immediately prepare your lawn mower for storage at the end of the season or if the unit will not be used for 30 days or more.

LAWN MOWER

When lawn mower is to be stored for a period of time, clean it thoroughly, remove all dirt, grease, leaves, etc. Store in a clean, dry area.

1. Clean entire lawn mower (See "CLEANING" in the Maintenance section of this manual).
2. Lubricate as shown in the Maintenance section of this manual.
3. Be sure that all nuts, bolts, screws, and pins are securely fastened. Inspect moving parts for damage, breakage and wear. Replace if necessary.
4. Touch up all rusted or chipped paint surfaces; sand lightly before painting.

HANDLE

You can fold your mower handle for storage.

NOTE: The upper handle has an "anti-fold" bracket located on the right side of the handle. This bracket prevents the upper handle from folding forward, which helps protect control cable(s) from damage.

1. Loosen the two (2) handle knobs on sides of the upper handle and allow handle to fold down to the rear.
 2. Squeeze the bottom ends of lower handle toward each other until pins in handle clear the brackets and pivot entire handle assembly forward and allow it to rest on mower.
- When setting up your handle from the storage position, you must manually lock lower handle into mowing position.

IMPORTANT: When folding the handle for storage or transportation, be sure to fold the handle as shown or you may damage the control cables.

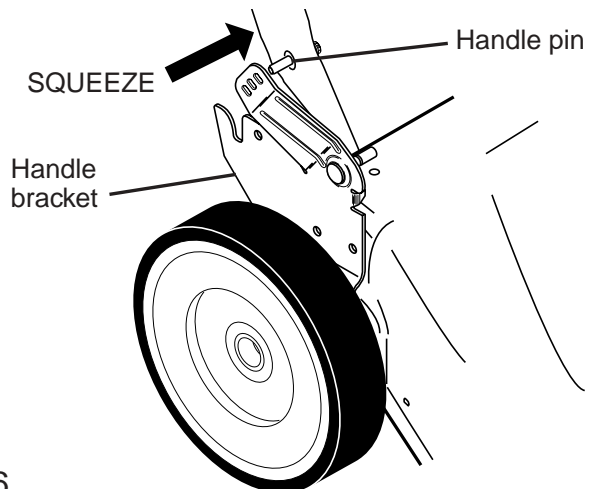
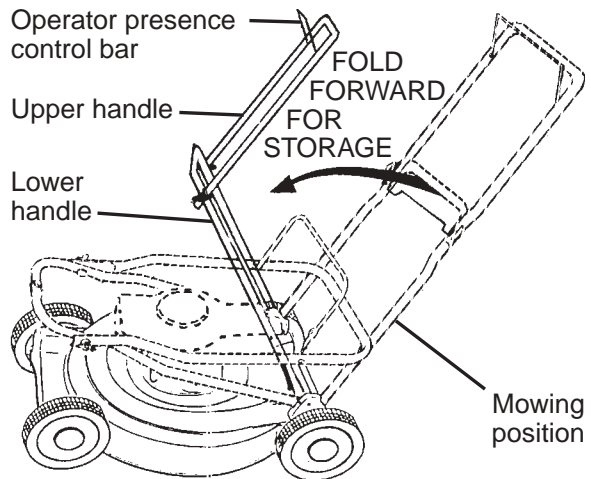

ENGINE

FUEL SYSTEM

IMPORTANT: It is important to prevent gum deposits from forming in essential fuel system parts such as carburetor, fuel filter, fuel hose or tank during storage.

Also, alcohol blended fuels (called gasohol or using ethanol or methanol) can attract moisture which leads to separation and formation of acids during storage. Acidic gas can damage the fuel system of an engine while in storage.

- Empty the fuel tank by starting the engine and letting it run until the fuel lines and carburetor are empty.
- Never use engine or carburetor cleaner products in the fuel tank or permanent damage may occur.
- Use fresh fuel next season.

NOTE: Fuel stabilizer is an acceptable alternative in minimizing the formation of fuel gum deposits during storage. Add stabilizer to gasoline in fuel tank or storage container. Always follow the mix ratio found on stabilizer container. Run engine at least 10 minutes after adding stabilizer to allow the stabilizer to reach the carburetor. Do not empty the gas tank and carburetor if using fuel stabilizer.

ENGINE OIL

Drain oil (with engine warm) and replace with clean engine oil. (See "ENGINE" in the Maintenance section of this manual).

CYLINDER

1. Remove spark plug.
2. Pour 29 ml of oil through spark plug hole into cylinder.
3. Pull starter handle slowly a few times to distribute oil.
4. Replace with new spark plug.

OTHER

- Do not store gasoline from one season to another.
- Replace your gasoline can if your can starts to rust. Rust and/or dirt in your gasoline will cause problems.
- If possible, store your unit indoors and cover it to protect it from dust and dirt.
- Cover your unit with a suitable protective cover that does not retain moisture. Do not use plastic. Plastic cannot breathe, which allows condensation to form and will cause your unit to rust.

IMPORTANT: Never cover mower while engine and exhaust areas are still warm.

⚠CAUTION: Never store the lawn mower with gasoline in the tank inside a building where fumes may reach an open flame or spark. Allow the engine to cool before storing in any enclosure.

TROUBLESHOOTING - See appropriate section in manual unless directed to a Sears Service Centre.

PROBLEM	CAUSE	CORRECTION
Does not start	<ol style="list-style-type: none"> 1. Dirty air filter. 2. Out of fuel. 3. Stale fuel. 4. Water in fuel. 5. Spark plug wire is disconnected. 6. Bad spark plug. 7. Loose blade or broken blade adapter. 8. Control bar in released position. 9. Control bar defective. 10. Fuel valve lever (if so equipped) in OFF position. 11. Weak battery (if equipped). 12. Disconnected battery connector (if equipped). 	<ol style="list-style-type: none"> 1. Clean/replace air filter. 2. Fill fuel tank. 3. Empty fuel tank and refill tank with fresh, clean gasoline. 4. Empty fuel tank and refill tank with fresh, clean gasoline. 5. Connect wire to plug. 6. Replace spark plug. 7. Tighten blade bolt or replace blade adapter. 8. Depress control bar to handle. 9. Replace control bar. 10. Turn fuel valve lever to the ON position. 11. Charge battery. 12. Connect battery to engine.
Loss of power	<ol style="list-style-type: none"> 1. Rear of lawn mower housing or cutting blade dragging in heavy grass. 2. Cutting too much grass. 3. Dirty air filter. 4. Buildup of grass, leaves, and trash under mower. 5. Too much oil in engine. 6. Walking speed too fast. 	<ol style="list-style-type: none"> 1. Raise cutting height. 2. Raise cutting height. 3. Clean/replace air filter. 4. Clean underside of mower housing. 5. Check oil level. 6. Cut at slower walking speed.

TROUBLESHOOTING - See appropriate section in manual unless directed to a Sears Service Centre.

PROBLEM	CAUSE	CORRECTION
Poor cut – uneven	<ol style="list-style-type: none"> 1. Worn, bent or loose blade. 2. Wheel heights uneven. 3. Buildup of grass, leaves and trash under mower. 	<ol style="list-style-type: none"> 1. Replace blade. Tighten blade bolt. 2. Set all wheels at same height. 3. Clean underside of mower housing.
Excessive vibration	<ol style="list-style-type: none"> 1. Worn, bent or loose blade. 2. Bent engine crankshaft. 	<ol style="list-style-type: none"> 1. Replace blade. Tighten blade bolt. 2. Contact a Sears or other qualified service center.
Starter rope hard to pull	<ol style="list-style-type: none"> 1. Engine flywheel brake is on when control bar is released. 2. Bent engine crankshaft. 3. Blade adapter broken. 4. Blade dragging in grass. 	<ol style="list-style-type: none"> 1. Depress control bar to upper handle before pulling starter rope. 2. Contact a Sears or other qualified service center. 3. Replace blade adapter. 4. Move lawn mower to cut grass or to hard surface.
Grass catcher not filling (If so equipped)	<ol style="list-style-type: none"> 1. Cutting height too low. 2. Lift on blade worn off. 3. Catcher not venting air. 	<ol style="list-style-type: none"> 1. Raise cutting height. 2. Replace blade. 3. Clean grass catcher.
Hard to push	<ol style="list-style-type: none"> 1. Grass is too high or wheel height is too low. 2. Rear of lawn mower housing or cutting blade dragging in grass. 3. Grass catcher too full. 4. Handle height position not right for you. 	<ol style="list-style-type: none"> 1. Raise cutting height. 2. Raise rear of lawn mower housing one (1) setting higher. 3. Empty grass catcher. 4. Adjust handle height to suit.
Loss of drive or slowing of drive speed	<ol style="list-style-type: none"> 1. Belt wear. 2. Belt off of pulley. 3. Drive cable worn or broken. 4. “Loose” drive control system. 	<ol style="list-style-type: none"> 1. Check/replace drive belt. 2. Check/reinstall drive belt. 3. Replace drive cable. 4. Adjust drive control.

REPAIR PARTS

CRAFTSMAN ROTARY LAWN MOWER -- MODEL NUMBER 944.364542

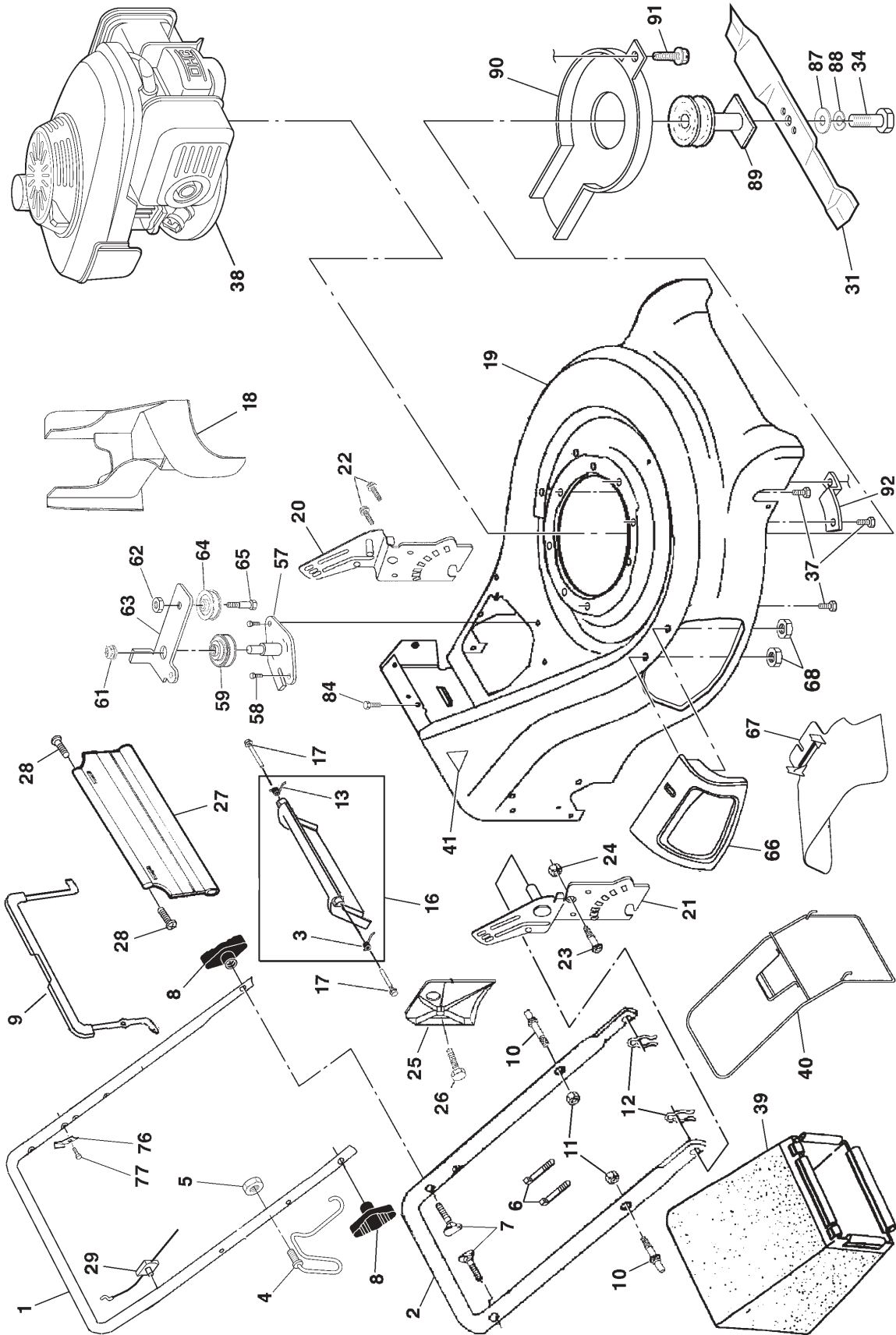

CRAFTSMAN ROTARY LAWN MOWER - - MODEL NUMBER 944.364542

KEY PART NO.	DESCRIPTION	KEY PART NO.	DESCRIPTION
1	189663X479 Handle, Upper	38	Engine, Honda, Model Number GCV160-AS3A (See Breakdown)
2	161105X479 Handle, Lower	39	Grassbag
3	186053 Spring, Rear Door, RH	40	Frame, Grassbag
4	186079 Rope Guide / Anti-Fold Bracket	41	Danger Decal
5	132004 Nut, Hex, with Lockwasher Insert 1/4-20	57	Bracket Assembly
6	66426 Wire, Tie	58	Screw
7	191574 Bolt, Handle 5/16-18 x 2-5/8	59	Pulley, V-Groove, Idler
8	189713X428 Knob, Handle	61	Flanged Nut
9	182810 Control Bar	62	Locknut
10	188821 Bolt, Carriage	63	Idler Arm
11	73930500 Nut, Hex, with Lockwasher Insert 5/16-18 UNC	64	Idler Pulley
12	51793 Cotter, Hairpin	65	Shoulder Bolt
13	186052 Spring, Rear Door, LH	66	Mulcher Door Assembly
16	185855X428 Kit, Rear Door (Includes Springs)	67	Discharge Guard
17	184193 Bolt, Rear Door	68	Nut, Hex
18	187535 Plug, Mulcher	76	Bracket, Upstop
19	181965 Kit, Housing	77	Screw
20	187249X479 Handle Bracket Assembly, LH	84	Screw
21	187250X479 Handle Bracket Assembly, RH	87	Washer
22	150078 Screw, Hex Washer Head	88	Washer, Lock
23	163183 Bolt, Hex Head 5/16-18 x 5/8	89	Blade Adapter / Pulley
24	73800500 Nut, Hex, with Lockwasher Insert 5/16-18	90	Debris Shield
25	161333 Baffle, Side	91	Screw
26	163409 Screw #12 x 5/8	92	Mounting Bracket, Debris Shield
27	188986 Skirt, Rear	--	Warning Decal (not shown)
28	88652 Screw, Hinge 1/4-20 x 1.25	--	Owner's Manual, English
29	191221 Cable, Engine Zone Control	--	Owner's Manual, French
31	189028 Blade, 21"		
34	851084 Bolt, Hex Head		
37	150406 Bolt, Engine		

NOTE: All component dimensions given in U.S. inches.
1 inch = 25.4 mm

CRAFTSMAN ROTARY LAWN MOWER -- MODEL NUMBER 944.364542

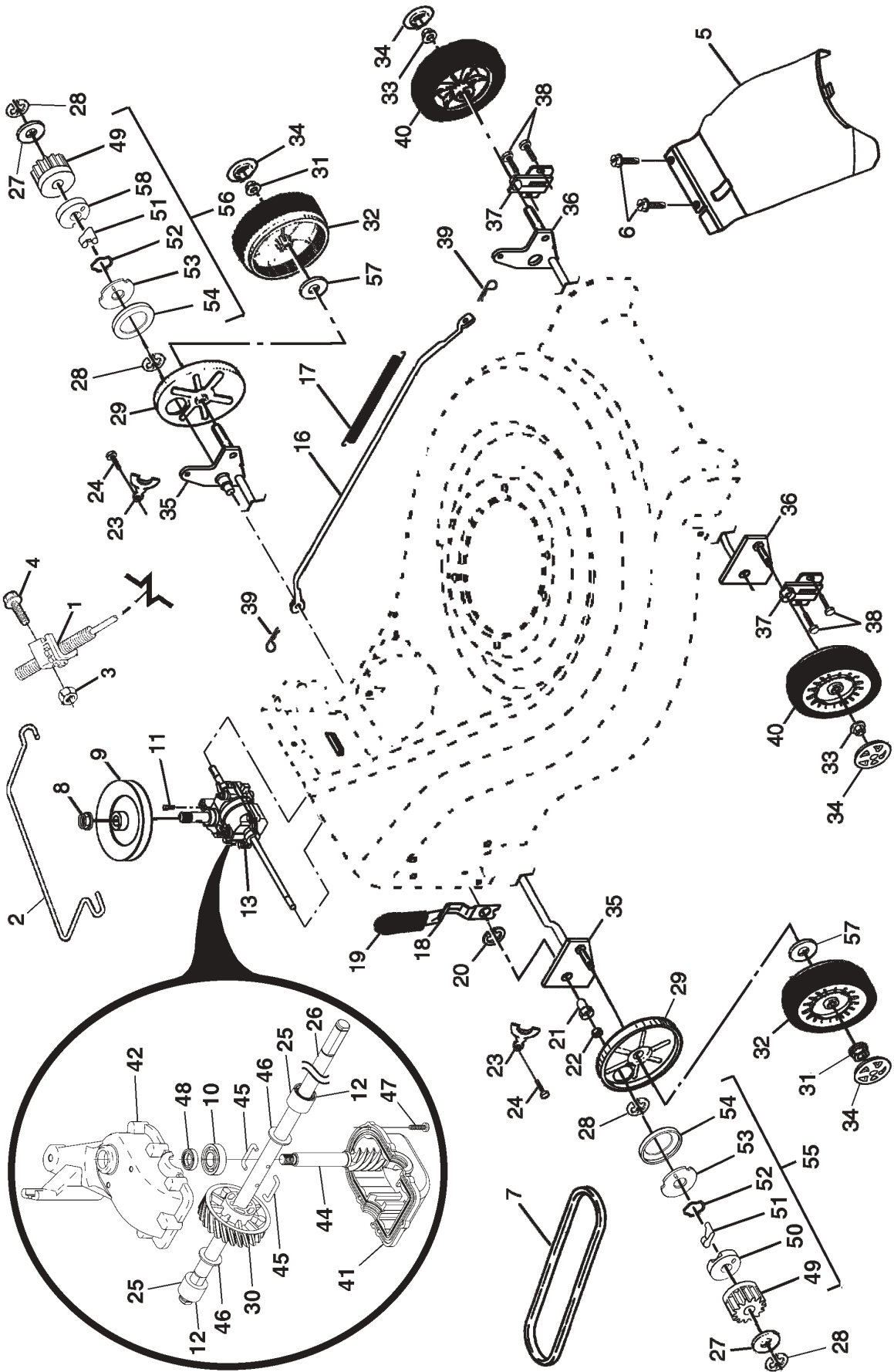

CRAFTSMAN ROTARY LAWN MOWER - - MODEL NUMBER 944.364542

KEY PART NO. NO.	DESCRIPTION	KEY PART NO. NO.	DESCRIPTION
1	189181	32	180774
2	189952X428	33	83923
3	751152	34	180626
4	185681	35	189180X004
5	161537X428	36	160786X004
6	750634	37	161463
7	182212	38	163409
8	132010	39	700279
9	189408	40	150339
10	183506	41	187530
11	187653	42	187531
12	183508	44	187533
13	188645	45	183505
16	161584	46	183509
17	161602	47	183513
18	189953X004	48	183514
19	167650	49	175103
20	12000022	50	175102
21	163365	51	175098
22	169911	52	188291
23	161118X004	53	175104
24	57808	54	184172
25	183511	55	188330
26	191249	56	188331
27	52160	57	67725
28	12000058	58	175105
29	189403		
30	187532		
31	145212		
	Drive Control Assembly		Wheel 9 x 2
	Control Bar, Drive		Nut, Flangelock 3/8-16
	Nut, Hex		Hubcap, Mag, Platinum
	Screw		Shaft Assembly, Rear
	Cover Drive		Shaft Assembly, Front
	Screw, Threaded, Rolled #10-25 x .50		Retainer, Front Shaft
	V-Belt		Screw #12 x 5/8
	Nut, Flangelock, Zinc Plated 3/8-16		Clip, Retainer
	Pulley, Drive		Wheel 8 x 2
	Bearing, Ball		* Case, Lower
	Screw		* Case, Upper
	Seal, Output Shaft		Shaft, Input
	Gear Case Assembly, Complete		Wire, Formed
	Rod, Connecting		Washer
	Spring, Extension		Screw
	Spring, Selector		Seal, Input Shaft
	Knob, Selector Spring		Pinion, Gear
	E-Ring 7/8		Retainer, Drive, RH
	Bearing, Support		Pawl
	Bearing, Ball		Spring, Torsion
	Retainer, Drive Assembly		Disc, Drive
	Screw, Tapping, Hex Head 1/4-20 x .75		Seal, Friction
	Bushing		Pinion Assembly, RH
	Shaft, Output		Pinion Assembly, LH
	Washer, Shim (as required)		Washer
	E-Ring 7/16		Retainer, Drive, LH
	Cover, Dust, Wheel		
	Gear, 24 Teeth		
	Nut, Flangelock		

* Use Dow Corning #709 to reseal Gear Case Halves.

NOTE: All component dimensions given in U.S. inches.
1 inch = 25.4 mm

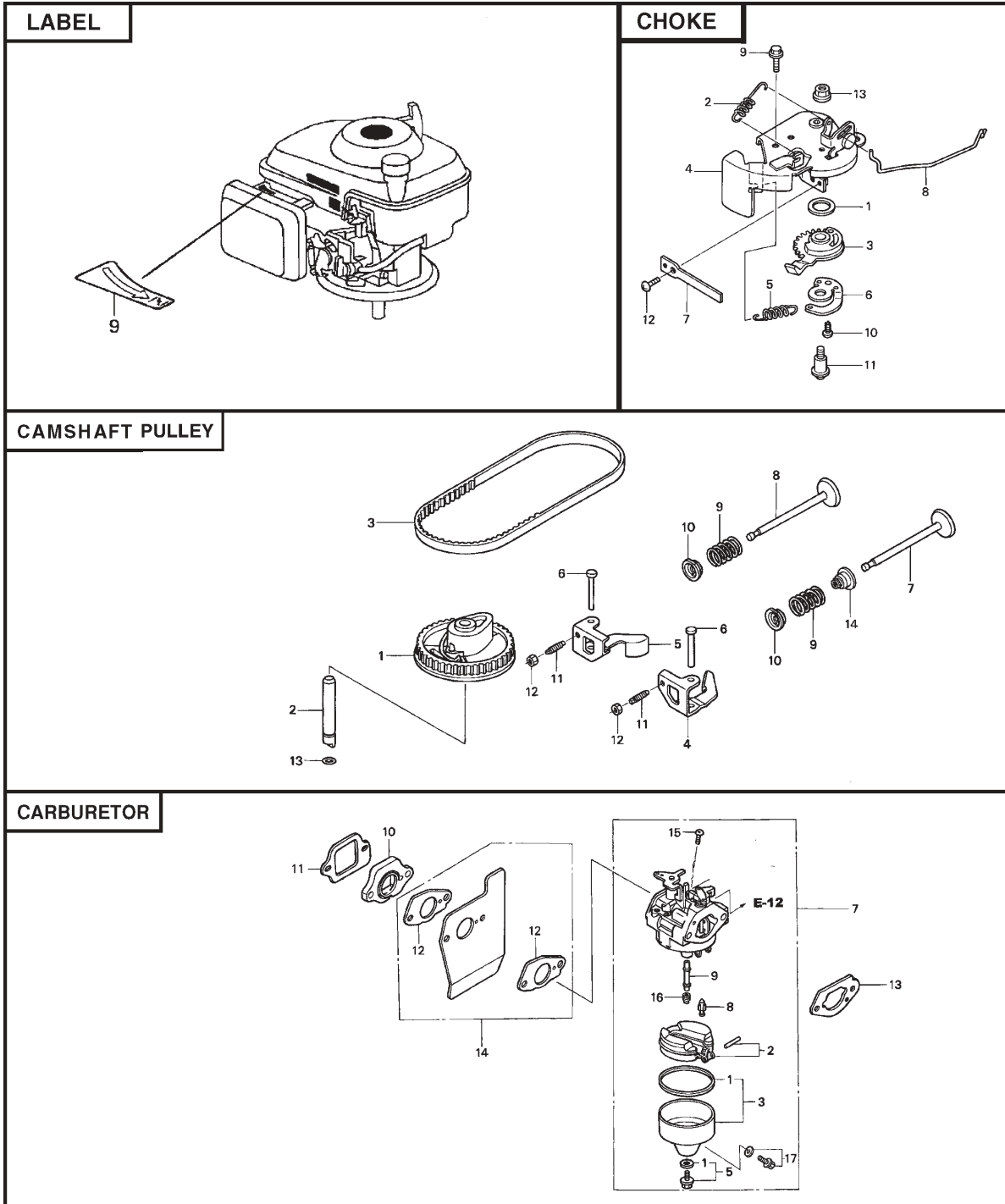

FAN COVER

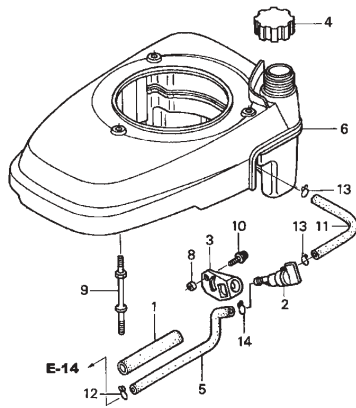

RECOIL STARTER

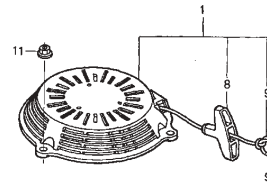

AIR CLEANER

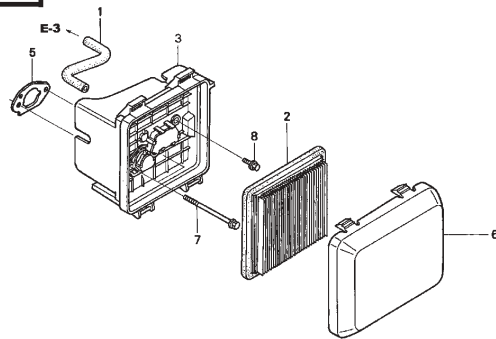

FLYWHEEL

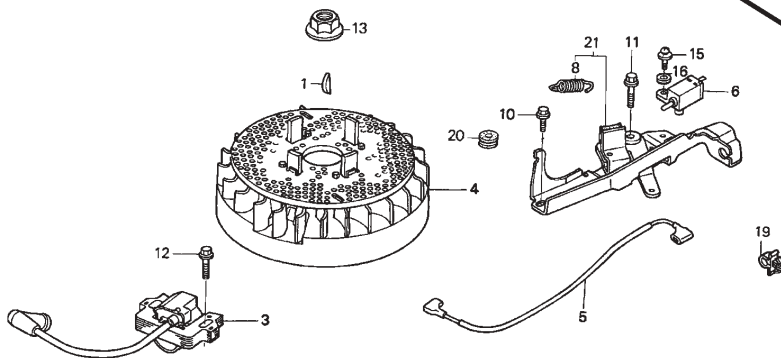

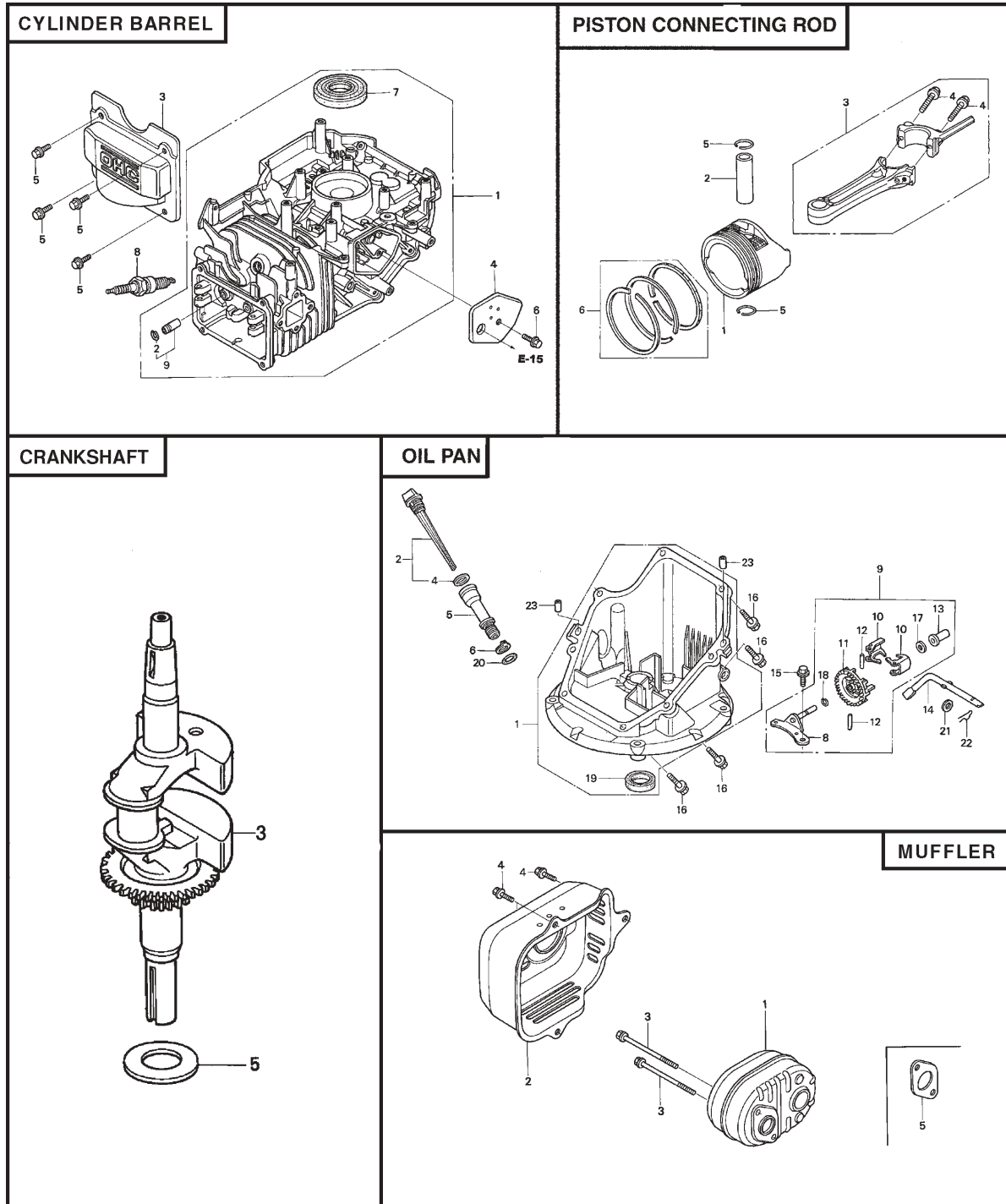

CHOKE

KEY NO.	PART NO.	DESCRIPTION
1	7257157	Seal, Choke Lever
2	4209581	Spring, Cable Return
3	7257165	Lever, Choke
4	7257173	Base Comp., Choke
5	7257181	Spring, Choke Lever
6	7257199	Hook, Choke Spring
7	7257207	Plate, Choke
8	7229867	Rod, Stop
9	0747733	Bolt, Flange #6 x 16
10	3674413	Screw, Tapping #4 x 8 (PO)
11	2544690	Screw, Pan Head #5 x 19
12	0369017	Screw, Pan Head #4 x 8
13	0636951	Nut, Flange 5 mm

CAMSHAFT PULLEY

KEY NO.	PART NO.	DESCRIPTION
1	7049679	Pulley Comp., Camshaft
2	5580063	Shaft, Cam Pulley
3	7058985	Belt, Timing (84HU7 G-200)
4	5580089	Rocker Arm, Intake Valve
5	5580097	Rocker Arm, Exhaust Valve
6	5580105	Shaft, Rocker Arm
7	5580113	Valve, Intake
8	5580121	Valve, Exhaust
9	5580139	Spring, Valve
10	1426980	Retainer, Intake Valve Spring
11	0294819	Screw, Tappet Adjusting
12	0004598	Nut, Tappet Adjusting
13	6315873	O-Ring 6.8 x 1.9 (ARAI)
14	6839831	Seal, Valve Stem

LABELS

KEY NO.	PART NO.	DESCRIPTION
9	7400187	Mark, Choke Indication

CARBURETOR

KEY NO.	PART NO.	DESCRIPTION
1	3088416	Packing Set
2	5580162	Float Set
3	3465879	Chamber Set, Float
5	1441518	Screw Set
7	7301138	Carburetor Assembly (BB62G A)
8	5580212	Valve, Float
9	5580220	Nozzle, Main
10	5580238	Insulator, Carburetor
11	5580246	Packing, Insulator
12	4581120	Packing, Carburetor
13	5580253	Packing, Carburetor
14	5580535	Guide Comp., Air
15	0639419	Screw, Pan Head #5 x 6
16	0635474	Jet, Main #60
	0635482	Jet, Main #62
	0636126	Jet, Main #65
17	1672187	Screw Set, Drain

FAN COVER

KEY NO.	PART NO.	DESCRIPTION
1	3683646	Rubber Supporter (107 mm)
2	7357379	Cock Assembly, Fuel
3	5189352	Bracket, Fuel Cock
4	6673289	Cap Assembly, Fuel Tank
5	5580469	Tube, Fuel
6	7399371	Cover Comp., Fan (T89)
8	6978399	Collar, Fuel Cock
9	5581004	Bolt, Stud
10	0671636	Screw, Washer Head #5 x 10
11	6754279	Tube, Fuel Tank
12	0250647	Clip, Tube (B8)
13	0250985	Clip, Tube (1310)
14	0053447	Clip, Tube (C9)

AIR CLEANER

KEY NO.	PART NO.	DESCRIPTION
1	5720289	Tube, Breather
2	6718159	Element, Air Cleaner
3	5580410	Case Assembly, Air Cleaner
5	5664560	Packing, Air Cleaner
6	6673255	Cover, Air Cleaner
7	5580964	Bolt, Flange #6 x 86 (CT200)
8	2374742	Bolt, Flange #6 x 14

RECOIL STARTER

KEY NO.	PART NO.	DESCRIPTION
1	6092886	Starter Assembly, Recoil
8	5580634	Grip, Starter
9	5580642	Rope, Recoil Starter
11	6478812	Nut, Flange 6 mm

PISTON / CONNECTING ROD

KEY NO.	PART NO.	DESCRIPTION
1	5580014	Piston
2	1426576	Pin, Piston
3	5580022	Rod Assembly, Connecting
4	1431055	Bolt, Connecting Rod
5	2605517	Clip, Piston Pin 13 mm
6	5655949	Ring Set, Piston (Riken)
	7154727	Ring Set, Piston (Teikoku)

CYLINDER BARREL

KEY NO.	PART NO.	DESCRIPTION
1	6842413	Barrel Assembly, Cylinder
2	2399780	Clip, Valve Guide
3	5579990	Cover, Head
4	5580006	Cover Comp., Breather
5	0636845	Bolt, Flange #6 x 12 (CT200)
6	0803619	Bolt, Flange #6 x 14 (CT200)
7	5581038	Oil Seal 25A x 62 x 6
8	1441112	Plug, Spark (BPR6ES) (NGK)
9	1899848	Guide, Exhaust Valve (O.S.)

FLYWHEEL

KEY NO.	PART NO.	DESCRIPTION
1	0348433	Key, Special, Woodruff #25 x 18
3	6859722	Coil Assembly, Ignition
4	6859714	Flywheel Assembly
5	6315816	Cord, Stop Switch
6	5580683	Switch Assembly, Engine Stop
8	5580790	Spring, Brake Lever
10	0803619	Bolt, Flange #6 x 14 (CT200)
11	1725050	Bolt, Flange #6 x 23 (CT200)
12	0671552	Bolt, Flange #6 x 20 (CT200)
13	0442038	Nut, Special 14 mm
15	0485946	Screw, Washer Head #4x12
16	1510361	Washer, Plain 4 mm
19	1824630	Clip A, Cable
20	1240845	Grommet A, Rear Cover
21	7301591	Brake Sub-Assembly

CRANKSHAFT

KEY NO.	PART NO.	DESCRIPTION
3	5664495	Crankshaft Comp.
5	5581012	Washer, Thrust

OIL PAN

KEY NO.	PART NO.	DESCRIPTION
1	6771489	Pan Assembly, Oil
2	5716915	Gauge Assembly, Oil Level
4	1452754	Packing, Oil Filler cap
5	5664503	Extension, Oil Filler
6	5664511	Washer, Extension Rock
8	6384341	Shaft Comp., Governor Holder
9	6384333	Governor Assembly
10	5580287	Weight, Governor
11	5580295	Holder, Governor Weight
12	1427244	Pin, Governor Weight
13	1427251	Slider, Governor
14	5580303	Shaft, Governor Arm
15	0803619	Bolt, Flange #6 x 14 (CT200)
16	0748111	Bolt, Flange #6 x 25
17	2413862	Washer, Thrust 6 mm
18	2456697	Clip, Governor Holder
19	5581046	Oil Seal 28 x 41.25 x 6
20	1377704	O-Ring 14.8 x 2.4 (NOK)
21	0345900	Washer, Plain 6 mm
22	0115527	Pin, Lock 8 mm
23	1417369	Dowel Pin #8 x 20

MUFFLER

KEY NO.	PART NO.	DESCRIPTION
1	5580485	Muffler Comp.
2	5664610	Protector, Muffler (CBU)
3	5580972	Bolt, Flange #6 x 79 (CT200)
4	0636845	Bolt, Flange #6 x 12 (CT200)
5	5737457	Gasket, Muffler

Get it fixed, at your home or ours!

Just Call:

1-800-4-MY-HOME®

(1-800-469-4663)

24 hours a day, 7 days a week

For the repair of major brand appliances **in your own home...**
no matter who made it, no matter who sold it!

For your nearest **Sears Parts and Service** location,
to bring in products like vacuums, lawn equipment and electronics.

For **Sears Parts & Service**, to order the replacement parts,
accessories and owner's manuals that you need to do-it-yourself.

www.sears.ca

To purchase or inquire about a Sears Maintenance Agreement, call:

1-800-361-6665

9 a.m. – 11 p.m. Mon. – Fri., EST, 9 a.m. – 4 p.m. Sat.

Pour service en français:

1-800-LE-FOYER^{MC}

(1-800-533-6937)

www.sears.ca



® / ™ Trademarks of Sears, Roebuck and Co. used under license by Sears Canada

^{MD} Marque déposée / ^{MC} Marque de commerce de Sears, Roebuck and Co. utilisée en vertu d'une licence de Sears Canada