

Owner's Manual



ROTARY LAWN MOWER

6.5 Horsepower

21" Multi-Cut

Model No.

944.364580



CAUTION:

Read and follow all
Safety Rules and Instructions
before operating this equipment

Sears Canada, Inc., Toronto, Ontario M5B 2B8

TABLE OF CONTENTS

Warranty	2	Maintenance	11-14
Safety Rules	2-3	Service and Adjustments.....	14-16
Product Specifications	4	Storage	16-17
Assembly / Pre-Operation	4-5	Troubleshooting	17-18
Operation.....	6-10	Repair Parts.....	19-27
Maintenance Schedule	11	Sears Service	Back Cover

WARRANTY

LIMITED TWO YEAR WARRANTY ON CRAFTSMAN POWER MOWER

For Two years from date of purchase Sears Canada, Inc. will repair or replace at Sears option free of charge parts which are defective as a result of material or workmanship. COMMERCIAL OR RENTAL USE:

Warranty on Power Mower (Gas) will be ninety (90) days from date of purchase if used for commercial or rental purposes.

This Warranty does NOT cover:

- Pre-delivery set-up.
- Expendable items which become worn during normal use, such as rotary mower blades, blade adapters, belts, air cleaners and spark plug.
- Repairs necessary because of operator abuse or negligence, including bent crankshafts and the failure to maintain the equipment according to the instructions contained in the owner's manual.

Warranty service is available by returning the Craftsman Power Mower to the nearest Sears Parts & Repair Centre in Canada. This warranty applies only while this product is used in Canada.

This warranty is in addition to any statutory warranty and does not exclude or limit legal rights you may have but shall run concurrently with applicable provincial legislation. Furthermore, some provinces do NOT allow limitation on how long an implied warranty will last so the above limitations may not apply to you.

Sears Canada, Inc., Toronto, Ontario M5B 2B8

SAFETY RULES

IMPORTANT: This cutting machine is capable of amputating hands and feet and throwing objects. Failure to observe the following safety instructions could result in serious injury or death.

⚠ Look for this symbol to point out important safety precautions. It means CAUTION!!! BECOME ALERT!!! YOUR SAFETY IS INVOLVED.

⚠ WARNING: In order to prevent accidental starting when setting up, transporting, adjusting or making repairs, always disconnect spark plug wire and place wire where it cannot come in contact with plug.

⚠ CAUTION: Muffler and other engine parts become extremely hot during operation and remain hot after engine has stopped. To avoid severe burns on contact, stay away from these areas.



I. GENERAL OPERATION

- Read, understand, and follow all instructions on the machine and in the manual(s) before starting. Be thoroughly familiar with the controls and the proper use of the machine before starting.
- Do not put hands or feet near or under rotating parts. Keep clear of the discharge opening at all times.
- Only allow responsible individuals, who are familiar with the instructions, to operate the machine.
- Clear the area of objects such as rocks, toys, wire, bones, sticks, etc., which could be picked up and thrown by the blade.
- Be sure the area is clear of other people before mowing. Stop machine if anyone enters the area.
- Do not operate the mower when barefoot or wearing open sandals. Always wear substantial foot wear.

- Do not pull mower backwards unless absolutely necessary. Always look down and behind before and while moving backwards.
- Do not operate the mower without proper guards, plates, grass catcher or other safety protective devices in place.
- See manufacturer's instructions for proper operation and installation of accessories. Only use accessories approved by the manufacturer.
- Stop the blade(s) when crossing gravel drives, walks, or roads.
- Stop the engine (motor) whenever you leave the equipment, before cleaning the mower or unclogging the chute.
- Shut the engine (motor) off and wait until the blade comes to complete stop before removing grass catcher.
- Mow only in daylight or good artificial light.
- Do not operate the machine while under the influence of alcohol or drugs.
- Never operate machine in wet grass. Always be sure of your footing: keep a firm hold on the handle and walk; never run.
- Disengage the self-propelled mechanism or drive clutch on mowers so equipped before starting the engine (motor).
- If the equipment should start to vibrate abnormally, stop the engine (motor) and check immediately for the cause. Vibration is generally a warning of trouble.
- Always wear safety goggles or safety glasses with side shields when operating mower.

II. SLOPE OPERATION

Slopes are a major factor related to slip and fall accidents which can result in severe injury. All slopes require extra caution. If you feel uneasy on a slope, do not mow it.

DO:

- Mow across the face of slopes: never up and down. Exercise extreme caution when changing direction on slopes.
- Remove obstacles such as rocks, tree limbs, etc.
- Watch for holes, ruts, or bumps. Tall grass can hide obstacles.

DO NOT:

- Do not trim near drop-offs, ditches or embankments. The operator could lose footing or balance.
- Do not trim excessively steep slopes.
- Do not mow on wet grass. Reduced footing could cause slipping.

III. CHILDREN

Tragic accidents can occur if the operator is not alert to the presence of children. Children are often attracted to the machine and the mowing activity. *Never* assume that children will remain where you last saw them.

- Keep children out of the trimming area and under the watchful care of another responsible adult.
- Be alert and turn machine off if children enter the area.
- Before and while walking backwards, look behind and *down* for small children.
- Never allow children to operate machine.
- Use extra care when approaching blind corners, shrubs, trees, or other objects that may obscure vision.

IV. SERVICE

- Use extra care in handling gasoline and other fuels. They are flammable and vapors are explosive.
 - Use only an approved container.
 - Never remove gas cap or add fuel with the engine running. Allow engine to cool before refueling. Do not smoke.
 - Never refuel the machine indoors.
 - Never store the machine or fuel container inside where there is an open flame, such as a water heater.
- Never run a machine inside a closed area.
- Never make adjustments or repairs with the engine (motor) running. Disconnect the spark plug wire, and keep the wire away from the plug to prevent accidental starting.
- Keep nuts and bolts, especially blade attachment bolts, tight and keep equipment in good condition.
- Never tamper with safety devices. Check their proper operation regularly.
- Keep machine free of grass, leaves, or other debris build-up. Clean oil or fuel spillage. Allow machine to cool before storing.
- Stop and inspect the equipment if you strike an object. Repair, if necessary, before restarting.
- Never attempt to make wheel height adjustments while the engine (motor) is running.
- Grass catcher components are subject to wear, damage, and deterioration, which could expose moving parts or allow objects to be thrown. Frequently check components and replace with manufacturer's recommended parts, when necessary.
- Mower blades are sharp and can cut. Wrap the blade(s) or wear gloves, and use extra caution when servicing them.
- Do not change the engine governor setting or overspeed the engine.

PRODUCT SPECIFICATIONS

Serial Number:	
Date of Purchase:	
Gasoline Capacity / Type:	0,94 Litres (Unleaded Regular)
Oil Capacity:	0,5 Litres
Oil Type (API SG–SL):	SAE 30 (above 0°C/32°F) or SAE 10W-30
Spark Plug (Gap: 0,76 mm)	NGK BPR6ES
Valve Clearance (± 0.04 mm):	Intake: 0.015 mm; Exhaust: 0.020 mm
Blade Bolt Torque:	35-40 ft. lbs. (47-54 N-m)
• The model and serial numbers will be found on a decal on the rear of the lawn mower housing. Record both serial number and date of purchase in space provided above.	

ASSEMBLY / PRE-OPERATION

Read these instructions and this manual in its entirety before you attempt to assemble or operate your new lawn mower.

IMPORTANT: This lawn mower is shipped WITHOUT OIL OR GASOLINE in the engine.

Your new lawn mower has been assembled at the factory with the exception of those parts left unassembled for shipping purposes. To ensure safe and proper operation of your lawn mower, all parts and hardware you assemble must be tightened securely. Use the correct tools as necessary to ensure proper tightness. All parts such as nuts, washers, bolts, etc., necessary to complete the assembly have been placed in the parts bag.

TO REMOVE LAWN MOWER FROM CARTON

1. Remove loose parts included with mower.
2. Cut down two end corners of carton and lay end panel down flat.
3. Remove all packing materials except padding between upper and lower handle and padding holding operator presence control bar to upper handle.
4. Roll lawn mower out of carton and check carton thoroughly for additional loose parts.

HOW TO SET UP YOUR LAWN MOWER

TO UNFOLD HANDLE

IMPORTANT: Unfold handle carefully so as not to pinch or damage control cables.

1. Raise lower handle section to operating position and align hole in handle with one of the height positioning holes in handle bracket.
2. Insert handle bolt through handle and bracket and secure with knob.
3. Repeat for opposite side of handle.
4. Remove protective padding, raise upper handle section into place on lower handle and tighten both handle knobs.
5. Remove any packing material from around control bar.

Your lawn mower handle can be adjusted for your mowing comfort. Refer to “ADJUST HANDLE” in the Service and Adjustments section of this manual.

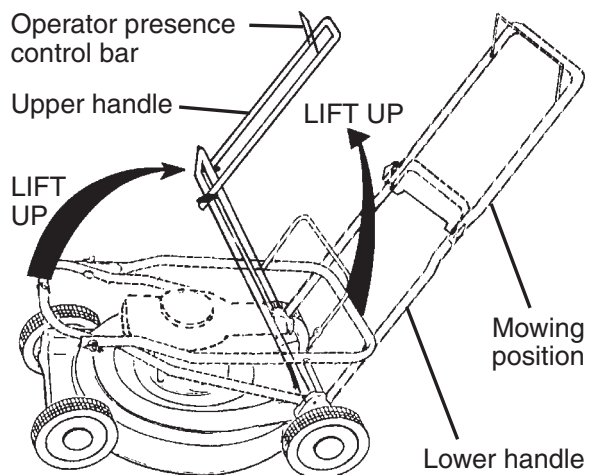

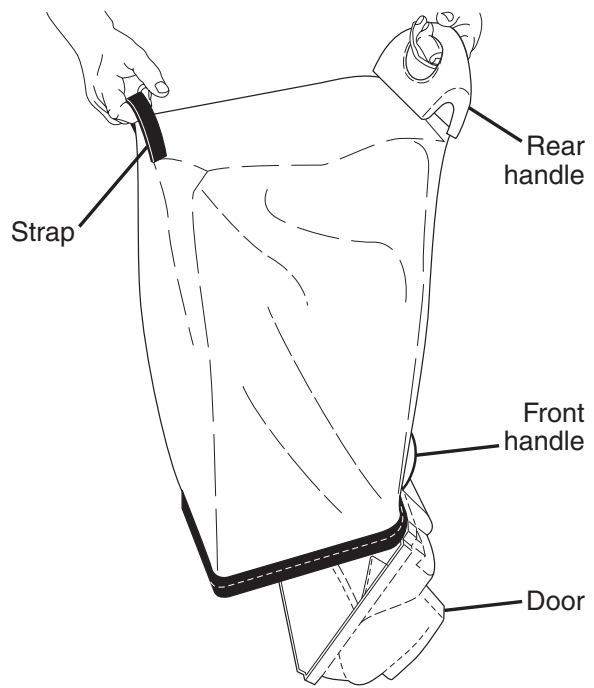
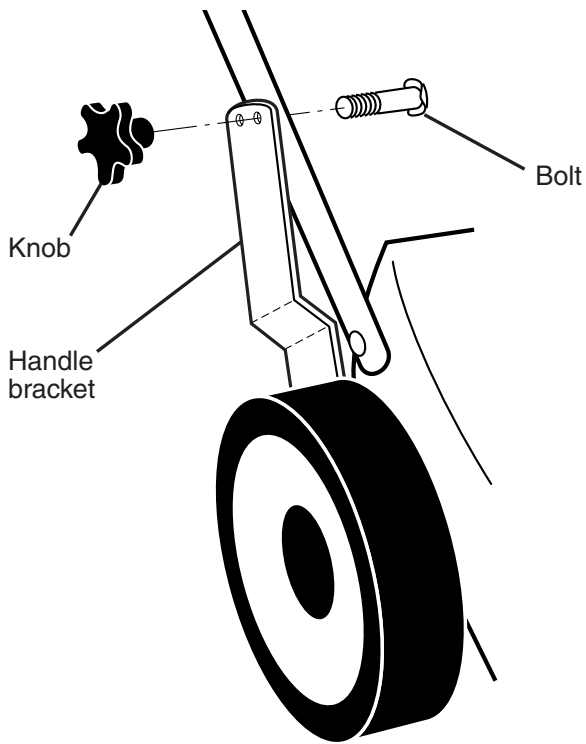

TO ASSEMBLE GRASS CATCHER

1. Slide grass catcher bag over the frame. Make sure the rear handle is on top (the same side as the front handle) and the strap is on the bottom.
2. Slip vinyl bindings over frame.

NOTE: If vinyl bindings are too stiff, hold them in warm water for a few minutes. If bag gets wet, let it dry before using.
3. Close grass catcher door.

NOTE: When fully closed, door will “snap” shut over frame and vinyl bindings.

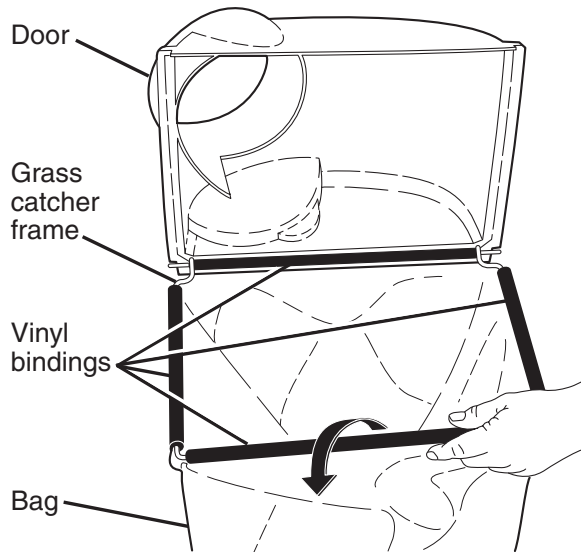

TO INSTALL ATTACHMENTS

Your lawn mower was shipped ready to be used as a mulcher. To convert mower to bagging or discharging, see “TO CONVERT MOWER” in the Operation section of this manual.

OPERATION

KNOW YOUR LAWN MOWER

READ THIS OWNER'S MANUAL AND ALL SAFETY RULES BEFORE OPERATING YOUR LAWN MOWER. Compare the illustrations with your lawn mower to familiarize yourself with the location of various controls and adjustments. Save this manual for future reference.

These symbols may appear on your lawn mower or in literature supplied with the product. Learn and understand their meaning.

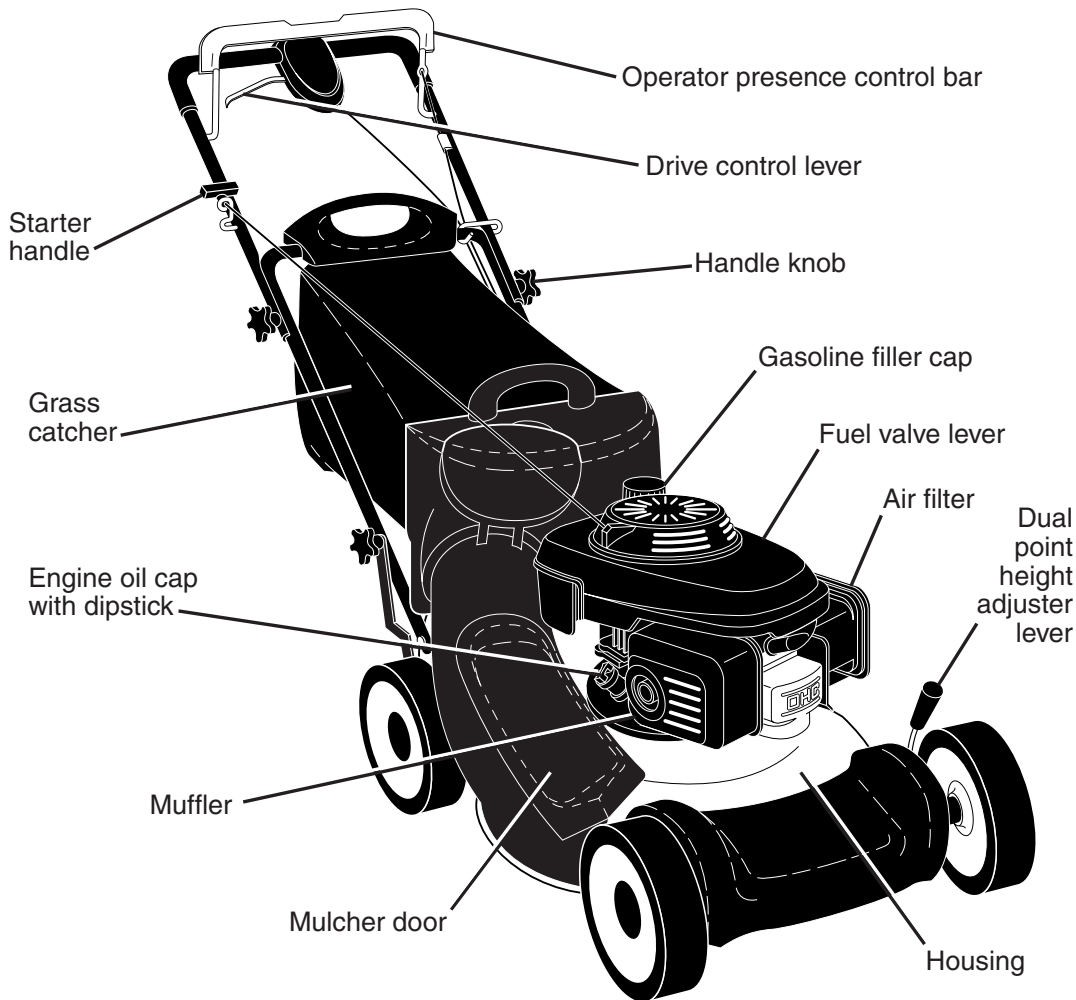
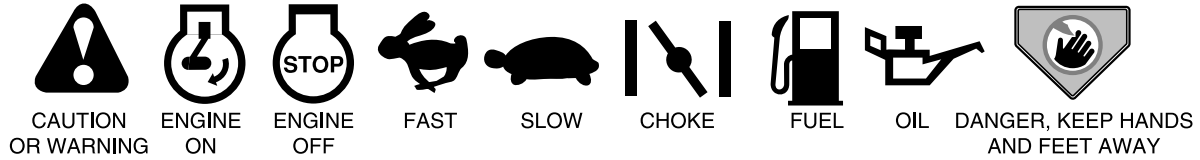

IMPORTANT: This lawn mower is shipped WITHOUT OIL OR GASOLINE in the engine.

MEETS CPSC SAFETY REQUIREMENTS

Sears rotary walk-behind power lawn mowers conform to the safety standards of the American National Standards Institute and the U.S. Consumer Product Safety Commission. The blade turns when the engine is running.

Operator presence control bar – must be held down to the handle to start the engine. Release to stop the engine.
Drive control lever – used to engage power-propelled forward motion of mower.

Starter handle – used for starting engine.
Mulcher door – allows conversion to discharging or bagging operation.
Dual point height adjuster – used to adjust cutting height of lawn mower.



The operation of any lawn mower can result in foreign objects thrown into the eyes, which can result in severe eye damage. Always

wear safety glasses or eye shields while operating your lawn mower or performing any adjustments or repairs. We recommend a standard safety glasses or wide vision safety mask worn over spectacles.

HOW TO USE YOUR LAWN MOWER ENGINE SPEED

The engine speed was set at the factory for optimum performance. Speed is not adjustable.

ENGINE ZONE CONTROL

CAUTION: Federal regulations require an engine control to be installed on this lawn mower in order to minimize the risk of blade contact injury. Do not under any circumstances attempt to defeat the function of the operator control. The blade turns when the engine is running.

- Your lawn mower is equipped with an operator presence control bar which requires the operator to be positioned behind the lawn mower handle to start and operate the lawn mower.

DRIVE CONTROL

- Self-propelling is controlled by holding the operator presence control bar down to the handle and pulling the drive control lever rearward to the handle. The farther toward the handle the lever is pulled, the faster the unit will travel.
- Forward motion will stop when either the operator presence control bar or drive control lever are released. To stop forward motion without stopping engine, release only the drive control lever. Hold operator presence control bar down against handle to continue mowing without self-propelling.

NOTE: If after releasing the drive control the mower will not roll backwards, push the mower forward slightly to disengage drive wheels.

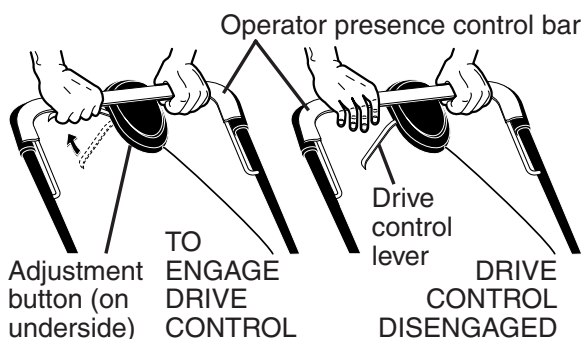

- To keep drive control engaged when turning corners, push down on the handle to lift the front wheels off the ground while turning lawn mower.

DRIVE CONTROL ADJUSTMENT

Over time, the drive control system may become “loose”, resulting in decreased speed. There is a button on the underside of the drive control housing to increase tension on the drive cable. Proceed as follows:

- Turn mower engine off and disconnect spark plug wire from spark plug.
- Pull out button on underside of drive control, then push it back in.
- Operate mower to see if drive speed has increased. If there is no increase, the drive belt is worn and needs to be replaced.

TO ADJUST CUTTING HEIGHT

Both front wheels are adjusted by a single lever on the left front wheel. Likewise, both rear wheels are adjusted by a single lever on the left rear wheel.

- Pull adjuster lever toward wheel. To raise mower, move lever forward to desired position. To lower mower, move the lever backward to desired position. Be sure to adjust both front and rear wheels to the same height.

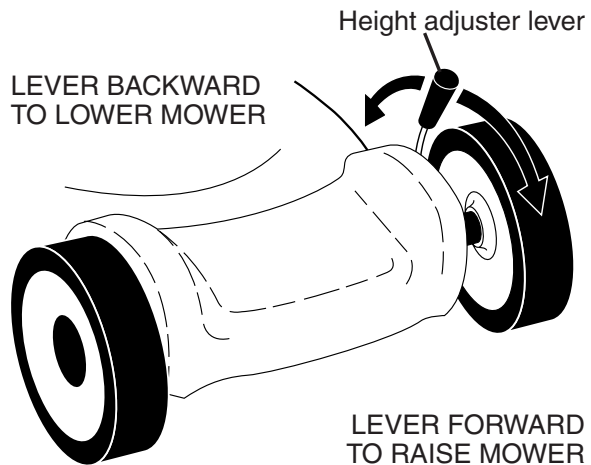

TO CONVERT MOWER

Your lawn mower was shipped ready to be used as a mulcher. To convert to rear bagging or side discharging:

REAR BAGGING

- Remove knob securing mulcher door to lawn mower housing.
- Open mulcher door and insert tabs of discharge chute into hinge bracket opening and position rear of chute over threaded stud.

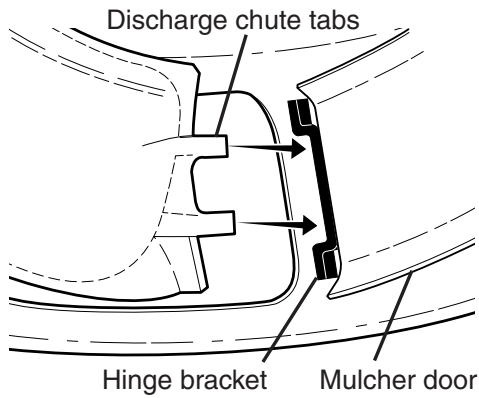

3. Secure rear of discharge chute to lawn mower housing with knob.
4. Place rear handle of grass catcher on the crossbar of the lawn mower's lower handle as shown.
5. Lift the round door of the discharge chute and place the grass catcher into place on the discharge chute.

NOTE: Be sure round door of discharge chute rests on grass catcher as shown.

- Mower is now ready for rear bagging operation.
- To convert to mulching operation, remove grass catcher and discharge chute. Secure mulcher door to mower housing with knob.
- To convert to side discharging operation, remove grass catcher and discharge chute. Install side discharge deflector and secure it to lawn mower housing with knob.

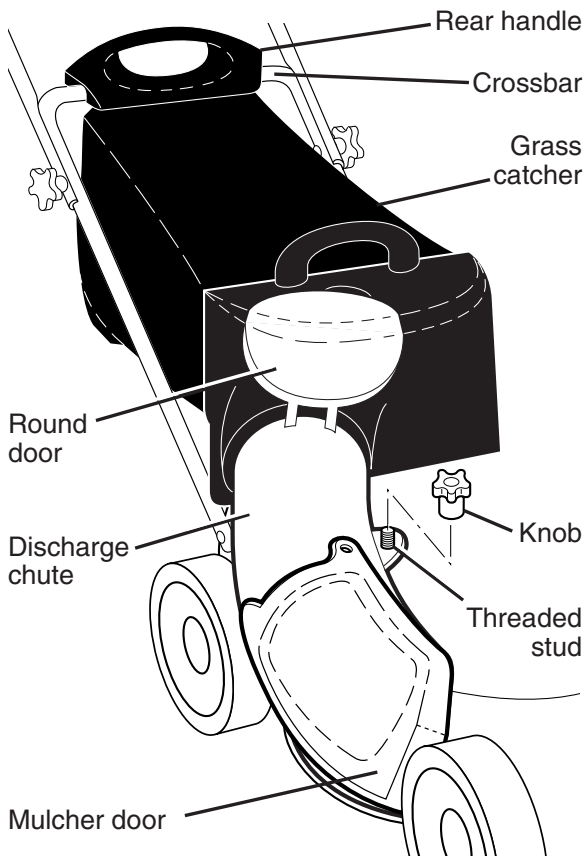

SIDE DISCHARGING

1. Grass catcher and discharge chute must be removed.
2. Open mulcher door and install front of side discharge deflector beneath it as shown.
3. Secure rear of side discharge deflector to lawn mower housing with knob.
 - Mower is now ready for side discharging operation.
 - To convert to mulching operation, side discharge deflector must be removed and mulcher door secured to mower housing with knob.
 - To convert to rear bagging operation, side discharge deflector must be removed; discharge chute and grass catcher installed and discharge chute secured to mower housing with knob.

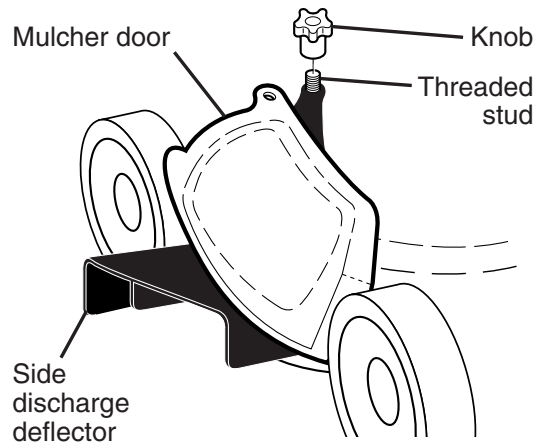

SIMPLE STEPS TO REMEMBER WHEN CONVERTING YOUR LAWN MOWER

FOR MULCHING -

1. Grass catcher, discharge chute and side discharge deflector removed.
2. Mulcher door secured to mower housing with knob.

FOR REAR BAGGING -

1. Side discharge deflector removed.
2. Grass catcher and discharge chute installed with discharge chute secured to lawn mower housing with knob.
3. Round door of discharge chute resting on top of grass catcher.

FOR SIDE DISCHARGING -

1. Grass catcher and discharge chute removed.
2. Side discharge deflector installed and secured to mower housing with knob.

CAUTION: Do not run your lawn mower without mulcher door closed; side discharge deflector installed, or discharge chute and approved grass catcher in place. Never attempt to operate the lawn mower with mulcher door or round door removed or propped open.

TO EMPTY GRASS CATCHER

1. Open round door of discharge chute to move starter rope out and away from grass catcher.

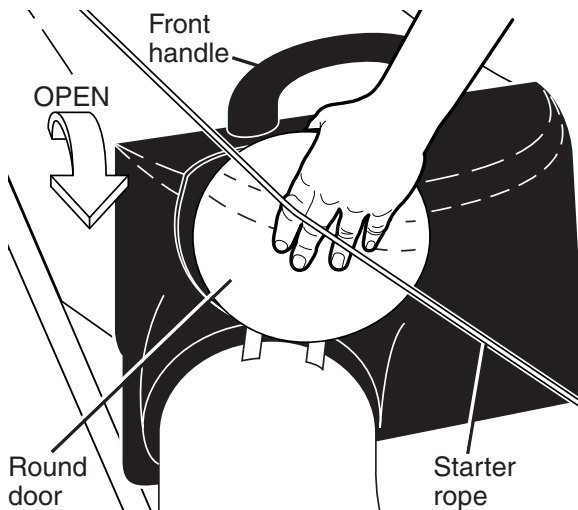

2. Remove grass catcher with clippings from lawn mower using both front and rear handles.
3. Empty clippings from grass catcher using both rear handle and strap. The weight of the grass will open the door.
4. Snap door shut over frame before installing grass catcher on mower.

NOTE: Do not drag the grass catcher when emptying; it will cause unnecessary wear.

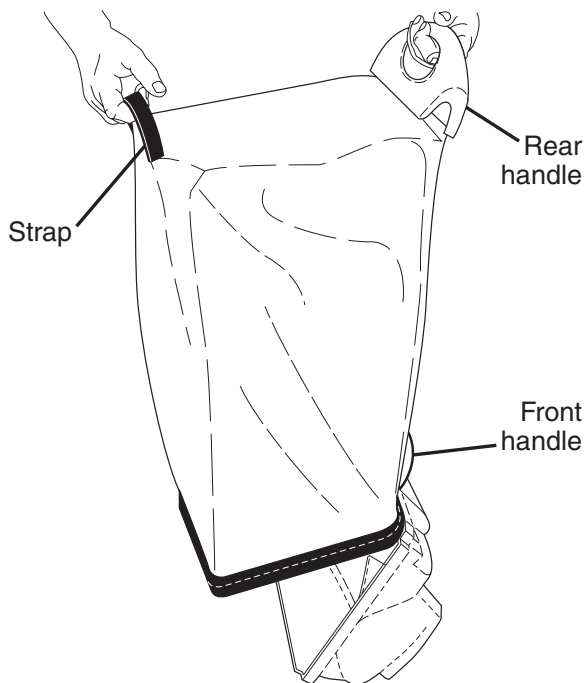

BEFORE STARTING ENGINE

ADD OIL

Your lawnmower is shipped without oil in the engine. For type and grade of oil to use, see "ENGINE" in the Maintenance section of this manual.

CAUTION: DO NOT overfill engine with oil, or it will smoke heavily from the muffler on startup.

1. Be sure lawnmower is level.
2. Remove oil dipstick from oil fill spout.
3. You receive a container of oil with the unit. Slowly pour the entire container down the oil fill spout into the engine.
4. Insert and tighten dipstick.

IMPORTANT:

- Check oil level before each use. Add oil if needed. Fill to full line on dipstick.
- Change the oil after every 25 hours of operation or each season. You may need to change the oil more often under dusty, dirty conditions. See "TO CHANGE ENGINE OIL" in the Maintenance section of this manual.

ADD GASOLINE

- Fill fuel tank to bottom of tank filler neck. Do not overfill. Use fresh, clean, regular unleaded gasoline with a minimum of 87 octane. Do not mix oil with gasoline. Purchase fuel in quantities that can be used within 30 days to assure fuel freshness.

CAUTION: Wipe off any spilled oil or fuel. Do not store, spill or use gasoline near an open flame.

CAUTION: Alcohol blended fuels (called gasohol or using ethanol or methanol) can attract moisture which leads to separation and formation of acids during storage. Acidic gas can damage the fuel system of an engine while in storage. To avoid engine problems, the fuel system should be emptied before storage of 30 days or longer. Empty the gas tank, start the engine and let it run until the fuel lines and carburetor are empty. Use fresh fuel next season. See Storage Instructions for additional information. Never use engine or carburetor cleaner products in the fuel tank or permanent damage may occur.

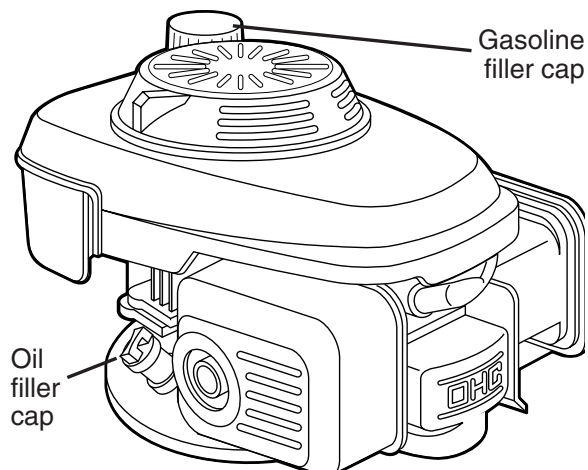

TO STOP ENGINE

- To stop engine, release operator presence control bar. Wait until blade and all moving parts have stopped and turn fuel valve to OFF position if you do not intend to restart the engine soon.

TO START ENGINE

NOTE: Due to protective coatings on the engine, a small amount of smoke may be present during the initial use of the product and should be considered normal.

1. Be sure fuel valve is in the ON position.
2. Move choke lever to ON () position.
3. Hold operator presence control bar down to the handle and pull starter handle quickly. Do not allow starter rope to snap back.

NOTE: The choke lever automatically begins moving to the OFF position when operator presence control bar is held down to handle.

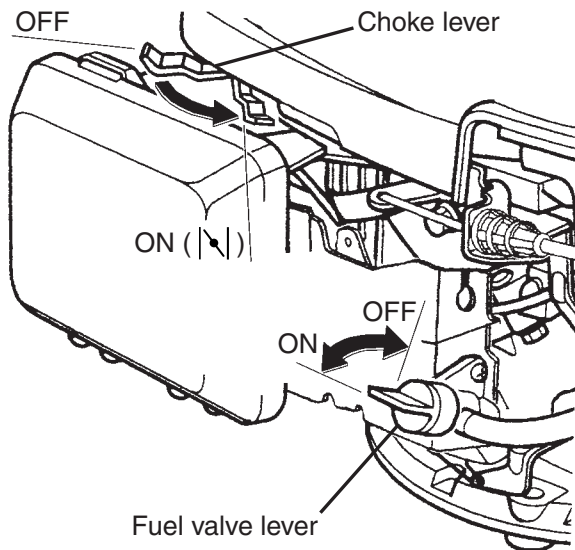

MOWING TIPS

- Under certain conditions, such as very tall grass, it may be necessary to raise the height of cut to reduce pushing effort and to keep from overloading the engine and leaving clumps of grass clippings. It may also be necessary to reduce ground speed and/or run the lawn mower over the area a second time.
- For extremely heavy cutting, reduce the width of cut by overlapping previously cut path and mow slowly.
- For better grass bagging and most cutting conditions, the engine speed should be set in the FAST position.
- Pores in cloth grass catchers can become filled with dirt and dust with use and catchers will collect less grass. To prevent this, regularly hose catcher off with water and let dry before using.

- Keep top of engine around starter clear and clean of grass clippings and chaff. This will help engine air flow and extend engine life.

MULCHING MOWING TIPS

IMPORTANT: For best performance, keep mower housing free of built-up grass and trash. See “CLEANING” in the Maintenance section of this manual.

- The special mulching blade will recut the grass clippings many times and reduce them in size so that as they fall onto the lawn they will disperse into the grass and not be noticed. Also, the mulched grass will biodegrade quickly to provide nutrients for the lawn. Always mulch with your highest engine (blade) speed as this will provide the best recutting action of the blades.
- Avoid cutting your lawn when it is wet. Wet grass tends to form clumps and interferes with the mulching action. The best time to mow your lawn is the early afternoon. At this time the grass has dried, yet the newly cut area will not be exposed to direct sunlight.
- For best results, adjust the lawn mower cutting height so that the lawn mower cuts off only the top one-third of the grass blades. If the lawn is overgrown it will be necessary to raise the height of cut to reduce pushing effort and to keep from overloading the engine and leaving clumps of mulched grass. For extremely heavy grass, reduce your width of cut by overlapping previously cut path and mow slowly.

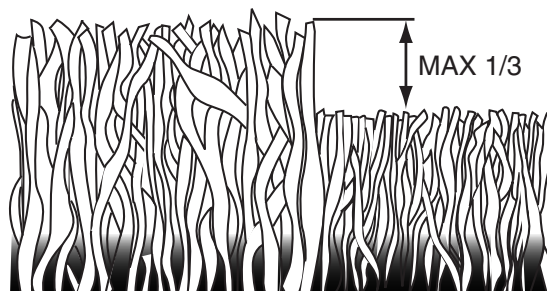

- Certain types of grass and grass conditions may require that an area be mulched a second time to completely hide the clippings. When doing a second cut, mow across (perpendicular) to the first cut path.
- Change your cutting pattern from week to week. Mow north to south one week then change to east to west the next week. This will help prevent matting and graining of the lawn.

MAINTENANCE

MAINTENANCE SCHEDULE		BEFORE EACH USE	AFTER EACH USE	EVERY 10 HOURS	EVERY 25 HOURS OR SEASON	EVERY 100 HOURS	BEFORE STORAGE
LAWNMOWER	Check for Loose Fasteners	✓					✓
	Clean / Inspect Grass Catcher *	✓	✓				✓
	Check Tires	✓					
	Check Drive Wheels ***	✓					
	Clean Lawn Mower ****		✓				✓
	Clean under Drive Cover ***			✓			
	Check Drive Belt / Pulleys ***				✓		
	Check / Sharpen / Replace Blade				✓ ₃		
ENGINE	Lubrication				✓		
	Clean and Recharge Battery **				✓		✓ ₄
	Check Engine Oil level	✓ ₅					
	Change Engine Oil				✓ _{1,2}		
	Clean Air Filter				✓ ₂		
	Inspect Muffler				✓		
	Replace Spark Plug					✓	
	Replace Air Filter Paper Cartridge					✓ ₂	
Empty fuel system or add Stabilizer						✓	

- * (if so equipped)
- ** Electric-Start mowers
- *** Power-Propelled mowers
- **** Use a scraper to clean under deck
- 1 - Change more often if operating under a heavy load or in high outdoor temperatures.
- 2 - Service more often if operating in dirty or dusty conditions.
- 3 - Replace blades more often when mowing in sandy soil.
- 4 - Charge 48 hours at end of season.
- 5 - And after each 5 hours of use.

GENERAL RECOMMENDATIONS

The warranty on this lawn mower does not cover items that have been subjected to operator abuse or negligence. To receive full value from the warranty, operator must maintain unit as instructed in this manual.

Some adjustments will need to be made periodically to properly maintain your unit.

At least once a season, check to see if you should make any of the adjustments described in the Service and Adjustments section of this manual.

- At least once a year, replace the spark plug, clean or replace air filter element and check blade for wear. A new spark plug and clean/new air filter element assure proper air-fuel mixture and help your engine run better and last longer.
- Follow the maintenance schedule in this manual.

BEFORE EACH USE

- Check engine oil level.
- Check for loose fasteners.

LUBRICATION

Keep unit well lubricated (See "LUBRICATION CHART").

LUBRICATION CHART

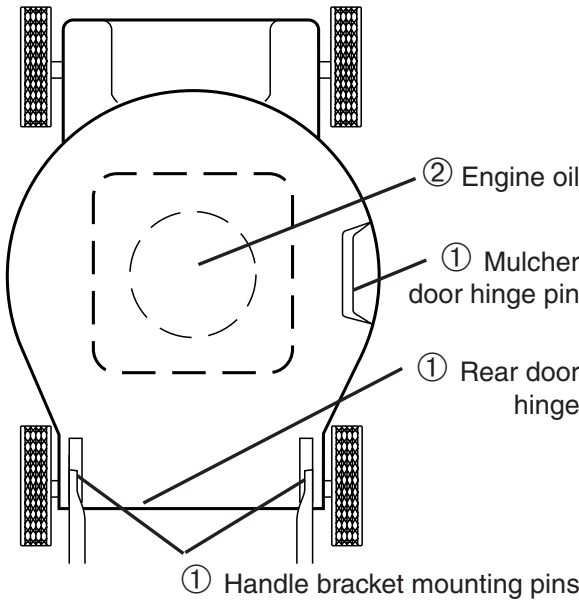

- ① Spray lubricant
- ② See "ENGINE" in Maintenance section.

IMPORTANT: Do not oil or grease plastic wheel bearings. Viscous lubricants will attract dust and dirt that will shorten the life of the self-lubricating bearings. If you feel they must be lubricated, use only a dry, powdered graphite type lubricant sparingly.

LAWN MOWER

Always observe safety rules when performing any maintenance.

TIRES

- Keep tires free of gasoline, oil, or insect control chemicals which can harm rubber.
- Avoid stumps, stones, deep ruts, sharp objects and other hazards that may cause tire damage.

DRIVE WHEELS

Check rear drive wheels each time you mow to be sure they move freely. The wheels not turning freely means trash, grass cuttings, etc., may be inside the drive wheel and dust cover area and must be cleaned out to free drive wheels.

BLADE CARE

For best results, mower blade must be kept sharp. Replace a bent or damaged blade.

TO REMOVE BLADE

1. Disconnect spark plug wire from spark plug and place wire where it cannot come in contact with plug.
2. Turn lawn mower on its side. Make sure air filter and carburetor are up.
3. Use a wood block between blade and mower housing to prevent blade from turning when removing blade bolt.

NOTE: Protect your hands with gloves and/or wrap blade with heavy cloth.

4. Remove blade bolt by turning counter-clockwise.
5. Remove blade and attaching hardware (bolt, lock washer, hardened washer).

TO REPLACE BLADE

1. Position blade on the blade adapter aligning the two (2) holes in the blade with the raised lugs on the adapter.
 2. Be sure the trailing edge of blade (opposite sharp edge) is up toward the engine.
 3. Install the blade bolt with the lock washer and hardened washer into blade adapter and crankshaft.
 4. Use block of wood between blade and lawn mower housing and tighten the blade bolt, turning clockwise.
- The recommended tightening torque is 35-40 ft. lbs.

IMPORTANT: Blade bolt is heat treated. If bolt needs replacing, replace only with approved bolt shown in the Repair Parts section of this manual.

TO SHARPEN BLADE

NOTE: We do not recommend sharpening the blade – but if you do, be sure the blade is balanced. Care should be taken to keep the blade balanced. An unbalanced blade will cause eventual damage to lawn mower or engine.

- The blade can be sharpened with a file or on a grinding wheel. Do not attempt to sharpen while on the mower.
- To check blade balance, drive a nail into a beam or wall. Leave about one inch of the straight nail exposed. Place center hole of blade over the head of the nail. If blade is balanced, it should remain in a horizontal position. If either end of the blade moves downward, sharpen the heavy end until the blade is balanced.

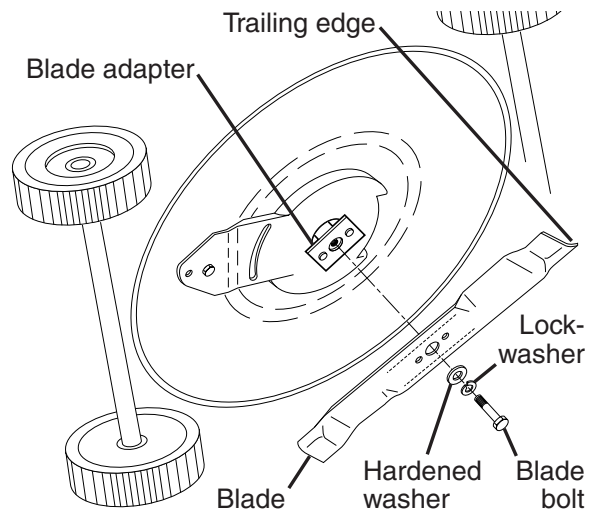

GRASS CATCHER

- The grass catcher may be hosed with water, but must be dry when used.
- Check your grass catcher often for damage or deterioration. Through normal use it will wear. If catcher needs replacing, replace only with approved replacement catcher shown in the Repair Parts section of this manual. Give the lawn mower model number when ordering.

GEAR CASE

- To keep your drive system working properly, the gear case and area around the drive should be kept clean and free of trash build-up. Clean under the drive cover twice a season.
- The gear case is filled with lubricant to the proper level at the factory. The only time the lubricant needs attention is if service has been performed on the gear case.
- If lubricant is required, use only Texaco Starplex Premium 1 Grease, Part No. 750369. Do not substitute.

ENGINE

Maintenance, repair, or replacement of the emission control devices and systems, which are being done at the customer's expense, may be performed by any non-road engine repair establishment or individual. Warranty repairs must be performed by an authorized engine manufacturer's service outlet.

⚠CAUTION: Disconnect spark plug wire from spark plug and place wire where it cannot come in contact with plug.

- Clean the underside of your lawn mower by scraping to remove build-up of grass and trash.
- Clean engine often to keep trash from accumulating. A clogged engine runs hotter and shortens engine life.
- Keep finished surfaces and wheels free of all gasoline, oil, etc.

- We do not recommend using a garden hose to clean lawn mower unless the electrical system, muffler, air filter and carburetor are covered to keep water out. Water in engine can result in shortened engine life.

CLEAN UNDER DRIVE COVER

Clean under drive cover at least twice a season. Scrape underside of cover with putty knife or similar tool to remove any build-up of trash or grass on underside of drive cover.

SERVICE AND ADJUSTMENTS

⚠WARNING: To avoid serious injury, before performing any service and adjustments:

1. Release control bar and stop engine.
2. Make sure the blade and all moving parts have completely stopped.
3. Disconnect spark plug wire from spark plug and place wire where it cannot come in contact with plug.

LAWN MOWER

TO ADJUST CUTTING HEIGHT

See "TO ADJUST CUTTING HEIGHT" in the Operation section of this manual.

REAR DEFLECTOR

The rear deflector, attached between the rear wheels of your mower, is provided to minimize the possibility that objects will be thrown out of the rear of the mower into the operator mowing position. If deflector becomes damaged, it should be replaced.

TO REMOVE DRIVE BELT

1. Disconnect spark plug wire from spark plug and place wire where it cannot come in contact with plug.
2. Remove screws retaining drive cover and remove drive cover from lawn mower housing (See Figure A).

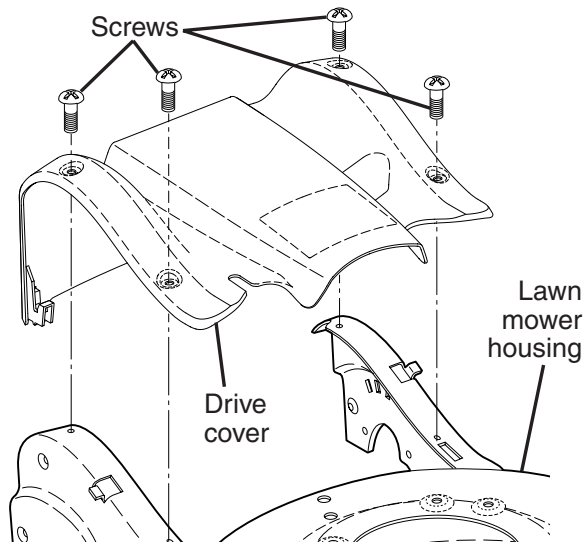

Figure A

3. Remove drive cable from anchor, then detach the drive cable spring from the idler arm assembly (See Figure B).

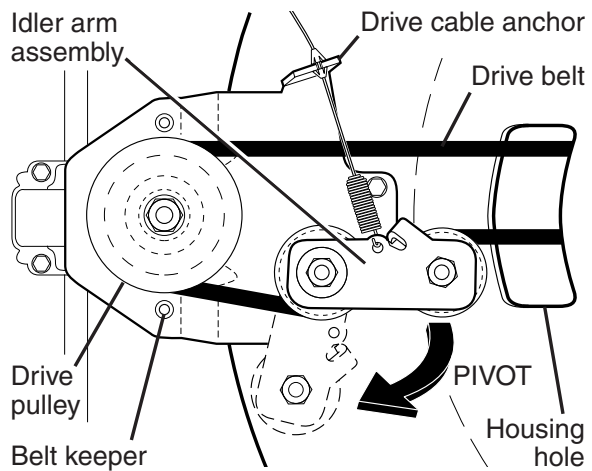

Figure B

4. Pivot idler arm assembly to slacken drive belt, then remove drive belt from drive pulley, belt keepers and idler arm.
5. Turn lawn mower on its side. Make sure air filter and carburetor are up.
6. Remove screw securing debris shield. Note that the debris shield has a tab which fits into a gap in the housing (See Figure C).

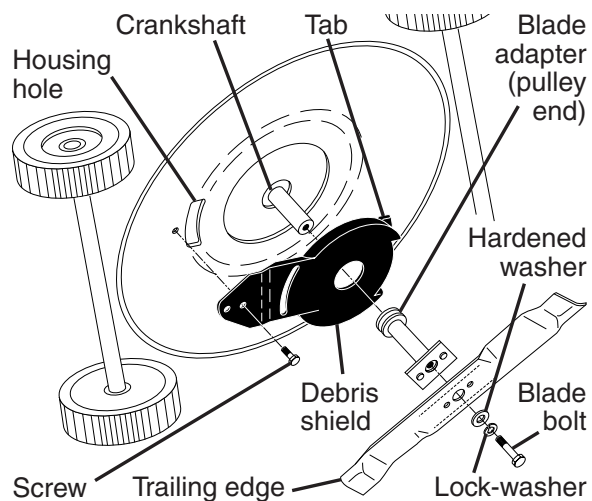

Figure C

7. Use a wood block between blade and mower housing to prevent blade from turning when removing blade bolt.
- NOTE:** Protect your hands with gloves and/or wrap blade with heavy cloth.
8. Remove blade bolt.
9. Remove blade, attaching hardware (bolt, lock washer and hardened washer), blade adapter and debris shield as one assembly.
10. Remove drive belt from blade adapter and debris shield; discard old belt.

TO REPLACE DRIVE BELT

1. Place new drive belt in the belt retainer of the debris shield. Be sure to route belt between belt keepers and through slot (See Figure D).

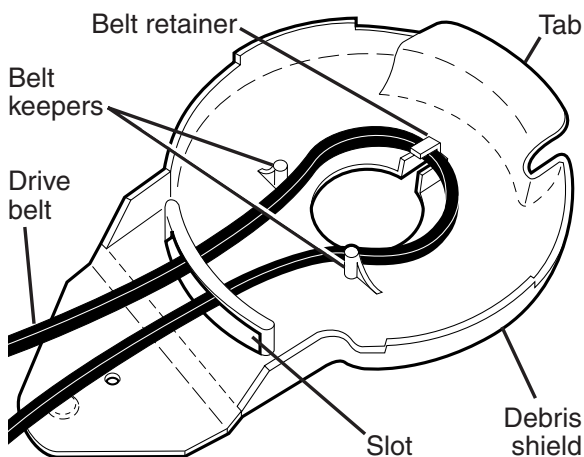

Figure D

2. Route the other end of the new drive belt through hole in housing.
3. Reattach debris shield to housing with screw previously removed. Be sure tab of debris shield is in gap of housing.
4. Position blade on the blade adapter aligning the two (2) holes in the blade with the raised lugs on the adapter.
5. Be sure the trailing edge of blade (opposite sharp edge) is up toward the engine (See Figure C).
6. Install the blade bolt with the lock washer and hardened washer into blade adapter and crankshaft.
7. Use block of wood between blade and lawn mower housing and tighten the blade bolt, turning clockwise.
 - The recommended tightening torque is 35-40 ft. lbs.

IMPORTANT: Blade bolt is heat treated. If bolt needs replacing, replace only with approved bolt shown in the Repair Parts section of this manual.

8. Return mower to upright position.

9. Install new drive belt into idler arm assembly, then around the drive pulley. Be sure belt is inside of belt keepers (See Figure B).

NOTE: Pulling on the drive belt (to install it on the drive pulley) will cause the other end of the belt to free itself from the debris shield retainer and properly seat itself in groove of pulley end of the blade adapter.

10. Reattach drive cable spring to the idler arm assembly, then reattach drive cable to anchor.
11. Reattach drive cover with screws previously removed.
12. Connect spark plug wire to spark plug.

TO ADJUST HANDLE

The handle on your lawn mower has multiple height positions - adjust to height that suits you.

1. Remove knob and carriage bolt on left side of the lower handle.
2. While holding handle assembly, remove knob and carriage bolt from right side. Align hole in handle with desired hole in handle bracket, then reassemble bolt and knob and tighten securely.
3. Align left side of handle with same positioning hole as right side and secure with bolt and knob.

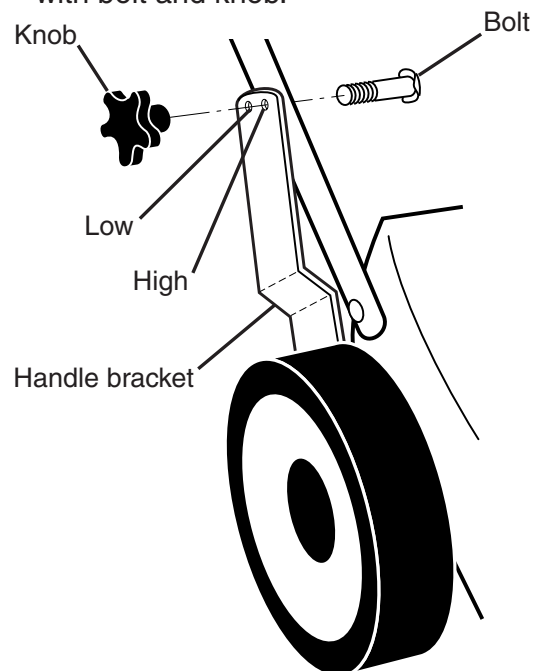

ENGINE

Maintenance, repair, or replacement of the emission control devices and systems, which are being done at the customer's expense, may be performed by any non-road engine repair establishment or individual. Warranty repairs must be performed by an authorized engine manufacturer's service outlet.

ENGINE SPEED

Your engine speed has been factory set. Do not attempt to increase engine speed or it may result in personal injury. If you believe that engine is running too fast or too slow, take your mower to a Sears or other qualified service center for repair and adjustment.

CARBURETOR

Your carburetor is not adjustable. If your engine does not operate properly due to suspected carburetor problems, take your lawn

mower to a Sears or other qualified service center for repair and/or adjustment.

IMPORTANT: Never tamper with the engine governor, which is factory set for proper engine speed. Overspeeding the engine above the factory high speed setting can be dangerous. If you think the engine-governed high speed needs adjusting, contact a Sears or other qualified service center, which has proper equipment and experience to make any necessary adjustments.

STORAGE

Immediately prepare your lawn mower for storage at the end of the season or if the unit will not be used for 30 days or more.

LAWN MOWER

When lawn mower is to be stored for a period of time, clean it thoroughly, remove all dirt, grease, leaves, etc. Store in a clean, dry area.

1. Clean entire lawn mower (See "CLEANING" in the Maintenance section of this manual).
2. Lubricate as shown in the Maintenance section of this manual.
3. Be sure that all nuts, bolts, screws, and pins are securely fastened. Inspect moving parts for damage, breakage and wear. Replace if necessary.
4. Touch up all rusted or chipped paint surfaces. Be sure to sand surface lightly before painting.

HANDLE

You can fold your lawn mower handle for storage.

NOTE: The upper handle has an "anti-fold" bracket located on the left side of the handle. This bracket prevents the upper handle from folding forward, which helps protect control cable(s) from damage.

1. Loosen the two (2) handle knobs on sides of the upper handle and allow handle to fold down to the rear.
2. Remove the two (2) handle knobs and carriage bolts on sides of the lower handle and pivot entire handle assembly forward and allow it to rest on mower.
3. Reinstall knobs and carriage bolts to lower handle or handle brackets for safe keeping.
- When setting up your handle from the storage position, you must manually lock lower handle into mowing position.

IMPORTANT: When folding the handle for storage or transportation, be sure to fold it as shown or you may damage the control cables.

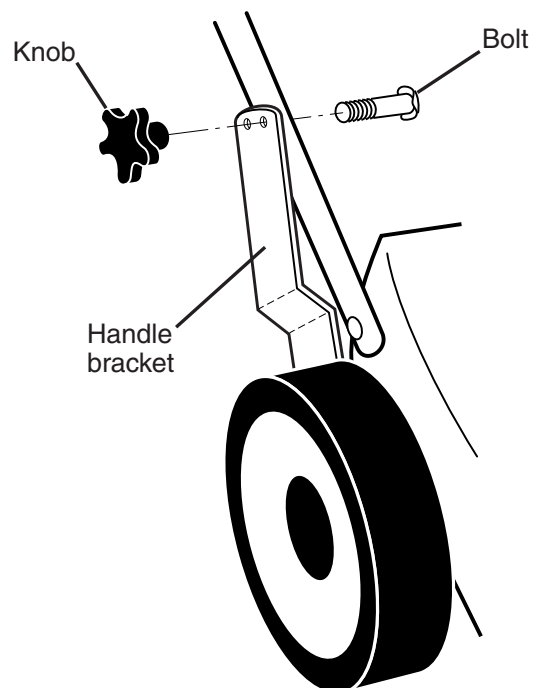
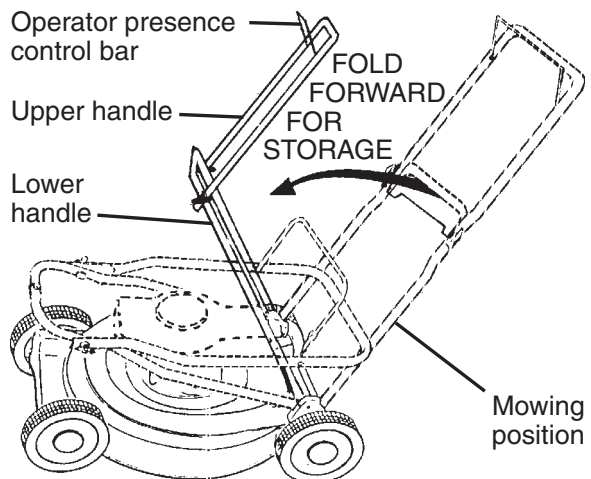

ENGINE

FUEL SYSTEM

IMPORTANT: It is important to prevent gum deposits from forming in essential fuel system parts such as carburetor, fuel filter, fuel hose, or tank during storage. Also, alcohol blended fuels (called gasohol or using ethanol or methanol) can attract moisture which leads to separation and formation of acids during storage. Acidic gas can damage the fuel system of an engine while in storage.

- Empty the fuel tank by starting the engine and letting it run until the fuel lines and carburetor are empty.
- Never use engine or carburetor cleaner products in the fuel tank or permanent damage may occur.
- Use fresh fuel next season.

NOTE: Fuel stabilizer is an acceptable alternative in minimizing the formation of fuel gum deposits during storage. Add stabilizer to gasoline in fuel tank or storage container. Always follow the mix ratio found on stabilizer container. Run engine at least 10 minutes after adding stabilizer to allow the stabilizer to reach the carburetor. Do not empty the gas tank and carburetor if using fuel stabilizer.

ENGINE OIL

Drain oil (with engine warm) and replace with clean engine oil. (See "ENGINE" in the Maintenance section of this manual).

CYLINDER

1. Remove spark plug.
2. Pour one ounce (29 ml) of oil through spark plug hole into cylinder.
3. Pull starter handle slowly a few times to distribute oil.
4. Replace with new spark plug.

OTHER

- Do not store gasoline from one season to another.
- Replace your gasoline can if your can starts to rust. Rust and/or dirt in your gasoline will cause problems.
- If possible, store your unit indoors and cover it to protect it from dust and dirt.
- Cover your unit with a suitable protective cover that does not retain moisture. Do not use plastic. Plastic cannot breathe, which allows condensation to form and will cause your unit to rust.

IMPORTANT: Never cover mower while engine and exhaust areas are still warm.

CAUTION: Never store the lawn mower with gasoline in the tank inside a building where fumes may reach an open flame or spark. Allow the engine to cool before storing in any enclosure.

TROUBLESHOOTING - See appropriate section in manual unless directed to a Sears Service Centre.

PROBLEM	CAUSE	CORRECTION
Does not start	<ol style="list-style-type: none">1. Dirty air filter.2. Out of fuel.3. Stale fuel.4. Water in fuel.5. Spark plug wire is disconnected.6. Bad spark plug.7. Loose blade or broken blade adapter.8. Control bar in released position.9. Control bar defective.10. Fuel valve lever (if so equipped) in OFF position.11. Weak battery (if equipped).12. Disconnected battery connector (if equipped).	<ol style="list-style-type: none">1. Clean/replace air filter.2. Fill fuel tank.3. Empty fuel tank and refill tank with fresh, clean gasoline.4. Empty fuel tank and refill tank with fresh, clean gasoline.5. Connect wire to plug.6. Replace spark plug.7. Tighten blade bolt or replace blade adapter.8. Depress control bar to handle.9. Replace control bar.10. Turn fuel valve lever to the ON position.11. Charge battery.12. Connect battery to engine.

TROUBLESHOOTING - See appropriate section in manual unless directed to a Sears Service Centre.

PROBLEM	CAUSE	CORRECTION
Loss of power	<ol style="list-style-type: none"> 1. Rear of mower housing or blade dragging in grass. 2. Cutting too much grass. 3. Dirty air filter. 4. Buildup of grass, leaves, and trash under mower. 5. Too much oil in engine. 6. Walking speed too fast. 	<ol style="list-style-type: none"> 1. Raise cutting height. 2. Raise cutting height. 3. Clean/replace air filter. 4. Clean underside of mower housing. 5. Check oil level. 6. Cut at slower walking speed.
Poor cut – uneven	<ol style="list-style-type: none"> 1. Worn, bent or loose blade. 2. Wheel heights uneven. 3. Buildup of grass, leaves and trash under mower. 	<ol style="list-style-type: none"> 1. Replace blade. Tighten blade bolt. 2. Set all wheels at same height. 3. Clean underside of mower housing.
Excessive vibration	<ol style="list-style-type: none"> 1. Worn, bent or loose blade. 2. Bent engine crankshaft. 	<ol style="list-style-type: none"> 1. Replace blade. Tighten blade bolt. 2. Contact a Sears or other qualified service center.
Starter rope hard to pull	<ol style="list-style-type: none"> 1. Engine flywheel brake is on when control bar is released. 2. Bent engine crankshaft. 3. Blade adapter broken. 4. Blade dragging in grass. 	<ol style="list-style-type: none"> 1. Depress control bar to upper handle before pulling the starter rope. 2. Contact a Sears or other qualified service center. 3. Replace blade adapter. 4. Move lawn mower to cut grass or to hard surface.
Grass catcher not filling (If so equipped)	<ol style="list-style-type: none"> 1. Cutting height too low. 2. Lift on blade worn off. 3. Catcher not venting air. 	<ol style="list-style-type: none"> 1. Raise cutting height. 2. Replace blade. 3. Clean grass catcher.
Hard to push	<ol style="list-style-type: none"> 1. Grass is too high or wheel height is too low. 2. Rear of mower housing or blade dragging in grass. 3. Grass catcher too full. 4. Handle height position not right for you. 	<ol style="list-style-type: none"> 1. Raise cutting height. 2. Raise rear of mower housing one (1) setting higher. 3. Empty grass catcher. 4. Adjust handle height to suit.
Loss of drive or slowing of drive speed	<ol style="list-style-type: none"> 1. Belt wear. 2. Belt off of pulley. 3. Drive cable worn or broken. 4. “Loose” drive control system. 	<ol style="list-style-type: none"> 1. Check/replace drive belt. 2. Check/reinstall drive belt. 3. Replace drive cable. 4. Adjust drive control.

REPAIR PARTS

CRAFTSMAN ROTARY LAWN MOWER - - MODEL NUMBER 944.364580 GEAR CASE ASSEMBLY - - PART NUMBER 188294

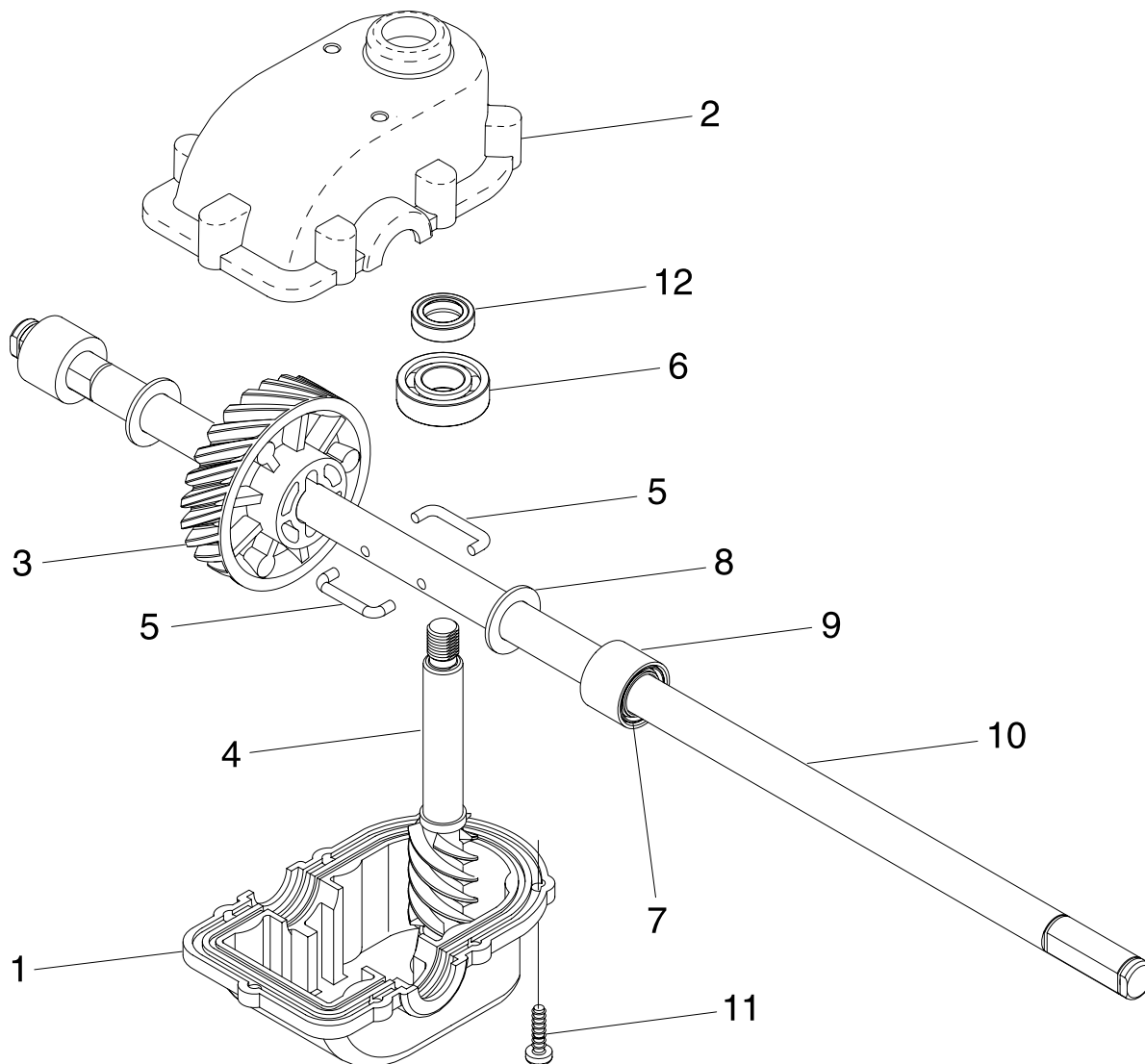

KEY NO.	PART NO.	DESCRIPTION
1	187530	Case, Lower
2	191245	Case, Upper
3	187532	Gear, 24 Teeth
4	191246	Shaft, Worm
5	183505	Wireform
6	183506	Bearing, Ball
7	183508	Seal, Output Shaft
8	183509	Washer
9	183511	Bushing
10	191247	Shaft, Output
11	183513	Screw
12	183514	Seal, Worm Shaft
--	750369	Grease, Texaco Starplex Premium 1 (Do not substitute) (1.4 ounce capacity)

NOTE: All component dimensions given in U.S. inches.
1 inch = 25.4 mm

CRAFTSMAN ROTARY LAWN MOWER -- MODEL NUMBER 944.364580

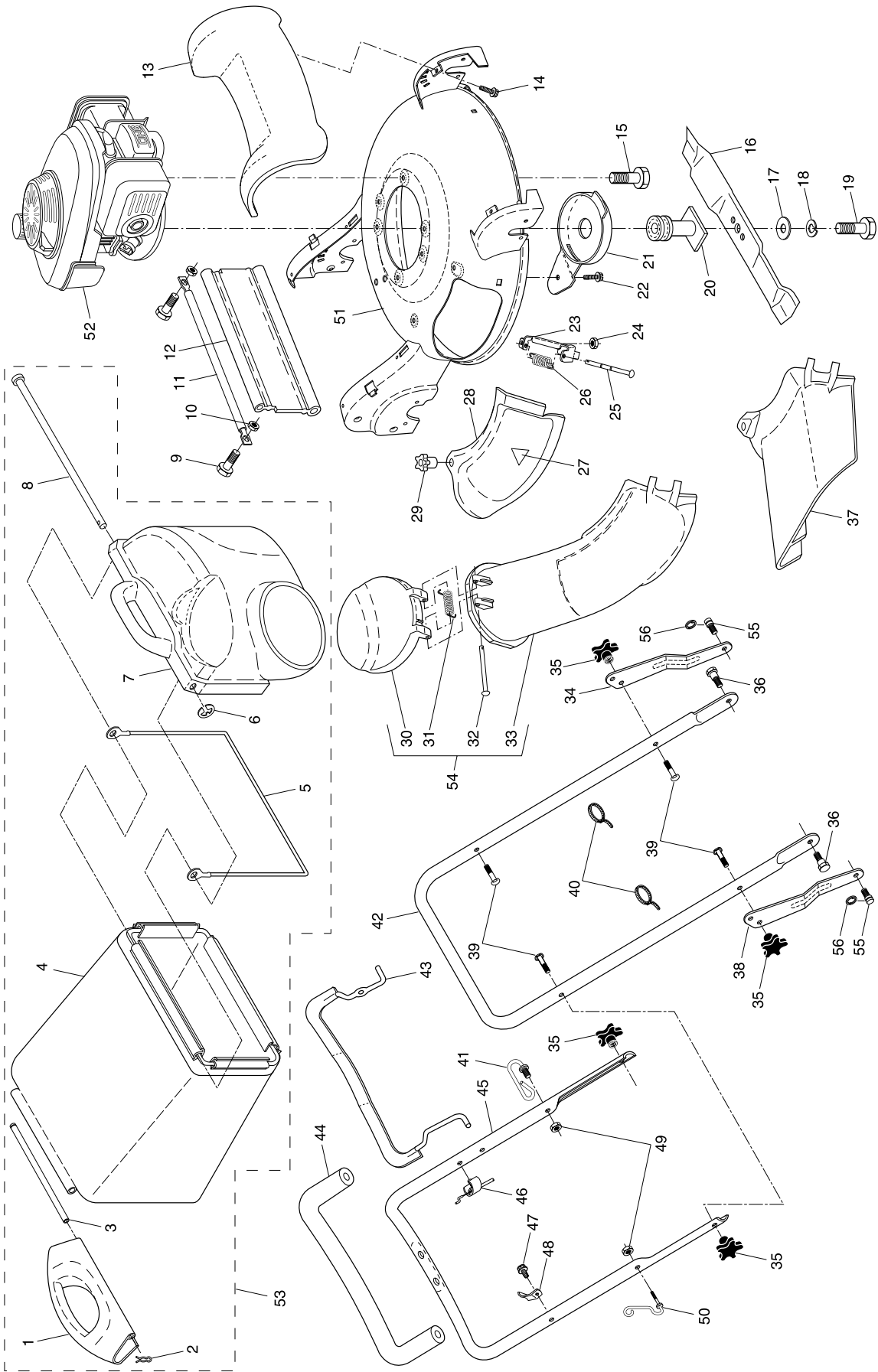

CRAFTSMAN ROTARY LAWN MOWER - - MODEL NUMBER 944.364580

KEY NO.	PART NO.	DESCRIPTION	KEY NO.	PART NO.	DESCRIPTION
1	188505X428	Handle, Grassbag, Rear	33	188504X428	Discharge Chute, Plastic
2	65322	Hairpin Cotter	34	187063X479	Adjustment Bracket, Lower Handle, LH
3	183483	Rod, Rear Handle, Grassbag	35	182398	Knob, Star
4	191271	Grassbag	36	183465	Bolt, Shoulder
5	188506	Frame, Grassbag	37	183613	Deflector, Discharge
6	12000014	E-Ring	38	187064X479	Adjustment Bracket, Lower Handle, RH
7	188498X428	Door, Grassbag	39	184568	Bolt, Handle
8	183479	Rod, Pivot	40	66426	Wire Tie
9	72140405	Screw	41	187162	Bracket, Anti-Fold
10	73800400	Nut, Hex	42	183464X479	Handle Assembly, Lower
11	188359X428	Tube, Rear Skirt	43	183474	Bail, Control
12	188503X428	Skirt, Rear	44	182748	Grip, Foam
13	183386	Cover, Front	45	184576	Handle Assembly, Upper (Includes Foam Grip)
14	184572	Screw, Hex Washer Head	46	183473	Cable, Engine Zone Control
15	150406	Bolt, Engine Mounting	47	184570	Screw
16	189028	Blade, 21"	48	86899X004	Bracket, Upstop
17	851074	Washer, Hardened	49	184569	Nut, Hex
18	850263	Washer, Lock	50	188501	Rope Guide
19	183431	Screw, Hex Head, Grade 8	51	190639	Kit, Housing
20	183428	Adapter, Blade	52	- - -	Engine, Honda, Model Number GCV190-AS3A (See Breakdown)
21	188510X428	Debris Shield	53	191272	Grassbag Assembly, Complete (Consists of Key Numbers 1-8)
22	17600406	Screw, Hex Head, Serrated	54	188614	Discharge Chute Assembly, Complete (Consists of Key Numbers 30-33)
23	183609	Mounting Bracket, Mulcher Door	55	188628	Stud, Shoulder, T45
24	751152	Nut, Hex	56	12000058	E-Ring, T45
25	183445	Rod, Hinge	- -	162300	Decal, Warning (not shown)
26	183446	Spring, Mulcher Door	- -	190637	Owner's Manual, English
27	107339X	Decal, Danger	- -	190638	Owner's Manual, French
28	188507X428	Mulcher Door			
29	183447	Knob			
30	188497X428	Door, Discharge Chute			
31	183478	Spring, Door, Discharge Chute			
32	183445	Rod, Door, Discharge Chute			

NOTE: All component dimensions given in U.S. inches.
1 inch = 25.4 mm

CRAFTSMAN ROTARY LAWN MOWER - - MODEL NUMBER 944.364580

KEY NO.	PART NO.	DESCRIPTION	KEY NO.	PART NO.	DESCRIPTION
1	183705	Drive Control Assembly, Complete (Consists of Key Numbers 2 through 7)	30	183457	Cover, Dust, Wheel
2	186297	Cover, Drive Control, Top	31	88348	Washer, Flat 3/8
3	187353	Pulley, Drive Control	32	188632	Wheel Assembly, Rear 9 x 2-1/4
4	190282	Lever, Drive Control (red)	33	83923	Nut, Hex
5	188276	Cover, Drive Control, Bottom	34	183442	Hubcap
6	181698	Screw, Torx Head #8-5/8	35	183437	Knob
7	184212X479	Bracket, Mounting, Drive Control	36	188291	Spring, Torsion
8	184987	Cap, Drive Control, Bottom	37	175098	Pawl
9	188280	Cable, Drive Control	38	12000058	E-Ring
10	188356X428	Cover Assembly, Drive	39	175103	Gear
11	184571	Screw	40	175105	Retainer, Drive, LH
12	12000012	Ring, Retaining	41	175104	Disc, Drive
13	183450	Screw	42	184172	Seal, Friction
14	187120	Bearing / Axle Support	43	188508X004	Lever, Selector, Wheel Height, Rear
15	188294	Gear Case Assembly (See Breakdown)	44	188509X004	Lever, Selector, Wheel Height, Front
16	132004	Nut, Hex	45	163409	Screw
17	189629X004	Bracket, Gear Case / Drive Pulley	46	184370	Wheel Assembly, Front 9 x 2-1/4
18	163409	Screw	47	183438	Bushing, Front Axle
19	189408	Pulley, Drive	48	169675	Retainer, Hairpin Cotter
20	132010	Nut, Hex, Flangelock	49	183692X004	Torque Shaft Assembly, Front
21	188611	Bolt, Idler	50	183688	Belt, Drive
22	184543	Pulley Assembly, V-Groove	51	188331	Pinion Assembly, LH
23	188152	O-Ring	52	175102	Retainer, Drive, RH
24	145212	Nut, Hex, Flangelock	53	183698X004	Rear Axle Assembly
25	73930500	Nut, Hex, Lock	54	188330	Pinion Assembly, RH
26	183700X004	Idler Arm	55	189835	Decal, Drive Control Operation
27	166043	Pulley, Idler	56	189836	Decal, Drive Control Adjustment (Bottom)
28	160829	Bolt, Hex Head, Shoulder	69	751068	Bearing, Ball (Wheel)
29	17060410	Screw 1/4-20 x 1/16			

NOTE: All component dimensions given in U.S. inches.
1 inch = 25.4 mm

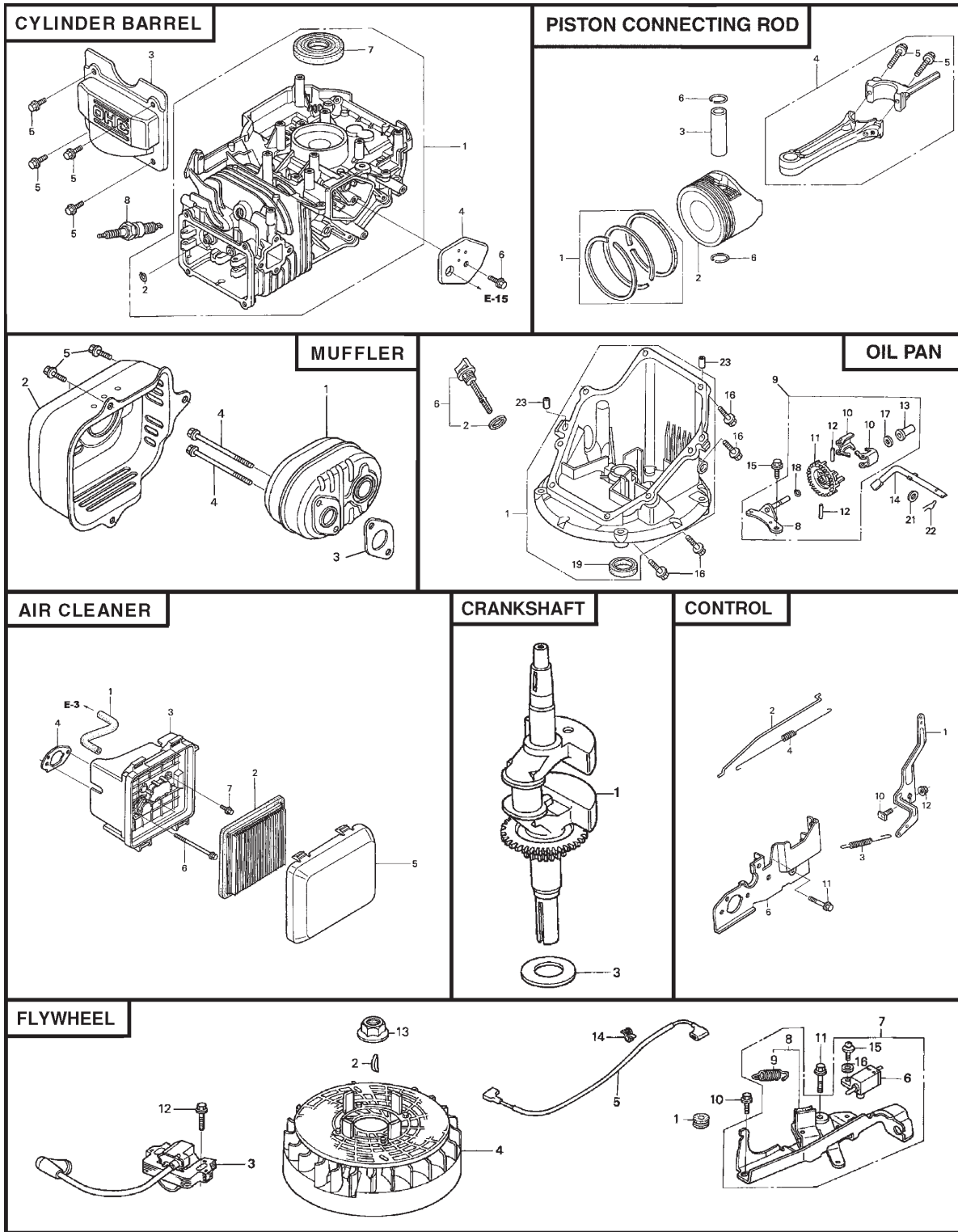

CYLINDER BARREL

KEY NO.	PART NO.	DESCRIPTION
1	7392236	Cylinder Assy
2	2399780	Clip, Valve Guide
3	5579990	Cover, Head
4	5580006	Cover, Breather (Breather Valve Assembly)
5	0636845	Bolt, Flange (#6 x 12) (CT200)
6	0803619	Bolt, Flange (#6 x 14)
7	5581038	Oil Seal (25.4 x 62 x 6)
8	1441112	Spark Plug (BPR6ES) (NGK)

PISTON / CONNECTING ROD

KEY NO.	PART NO.	DESCRIPTION
1	7357288	Ring Set, Piston (Teikoku)
2	7379696	Piston
3	7370133	Pin, Piston
4	7370141	Rod Assembly, Connecting
5	1431055	Bolt, Connecting Rod
6	2605517	Clip, Piston Pin (13 mm)

MUFFLER

KEY NO.	PART NO.	DESCRIPTION
1	7357403	Muffler
2	5580501	Protector, Muffler
3	5737457	Gasket, Muffler
4	5580972	Bolt, Flange (#6 x 79) (CT200)
5	0636845	Bolt, Flange (#6 x 12) (CT200)

OIL PAN

KEY NO.	PART NO.	DESCRIPTION
1	7392897	Pan Assembly, Oil
2	4497947	Gasket, Oil Filler Cap
6	5722996	Dipstick, Oil
8	6384341	Shaft, Governor Holder
9	6384333	Governor Assembly
10	5580287	Weight, Governor
11	5580295	Holder, Governor Weight
12	1427244	Pin, Governor Weight
13	1427251	Slider, Governor
14	5580303	Shaft, Governor Arm
15	0803619	Bolt, Flange (#6 x 14)
16	0748111	Bolt, Flange (#6 x 25)
17	2413862	Washer, Thrust (6 mm)
18	2456697	Clip, Governor Holder
19	5581046	Oil Seal (28 x 41.25 x 6)
21	0345900	Washer, Plain (6 mm)
22	0115527	Pin, Lock (8 mm)
23	1417369	Pin, Dowel (#8 x 20)

AIR CLEANER

KEY NO.	PART NO.	DESCRIPTION
1	5580154	Tube, Breather
2	6718159	Element, Air Cleaner
3	5580410	Case Assembly, Air Cleaner
4	5664560	Gasket, Air Cleaner
5	7356025	Cover, Air Cleaner "NH1" (Black)
	7399397	Cover, Air Cleaner "R280" (Power Red)
6	5580964	Bolt, Flange (#6 x 86) (CT200)
7	2374742	Bolt, Flange (#6 x 14)

CRANKSHAFT

KEY NO.	PART NO.	DESCRIPTION
1	7357312	Crankshaft (N3-type)
3	5581012	Washer, Thrust

CONTROL

KEY NO.	PART NO.	DESCRIPTION
1	6869630	Arm, Governor
2	7229859	Rod, Governor
3	5580345	Spring, Governor
4	5580352	Spring, Throttle Return
6	6978415	Base, Control
10	2418671	Bolt, Governor Arm
11	2488187	Bolt, Flange (#6 x 45)
12	0471623	Nut, Flange (6 mm)

FLYWHEEL

KEY NO.	PART NO.	DESCRIPTION
1	1240845	Grommet A, Rear Cover
2	0348433	Key, Special, Woodruff (25 x 18)
3	6859722	Coil Assembly, Ignition
4	7357502	Flywheel Assembly
5	6315816	Wire, Stop Switch
6	5580683	Switch Assembly, Engine Stop
8	7301591	Brake Sub-Assembly
9	5580790	Spring, Brake Lever
10	0803619	Bolt, Flange (#6 x 14)
11	1725050	Bolt, Flange (#6 x 23)
12	0671552	Bolt, Flange (#6 x 20) (CT200)
13	6352561	Nut, Flange (14 mm)
14	1824630	Clip, Cable (A)
15	0485946	Screw-washer (#4 x 12)
16	1510361	Washer, Plain (4 mm)

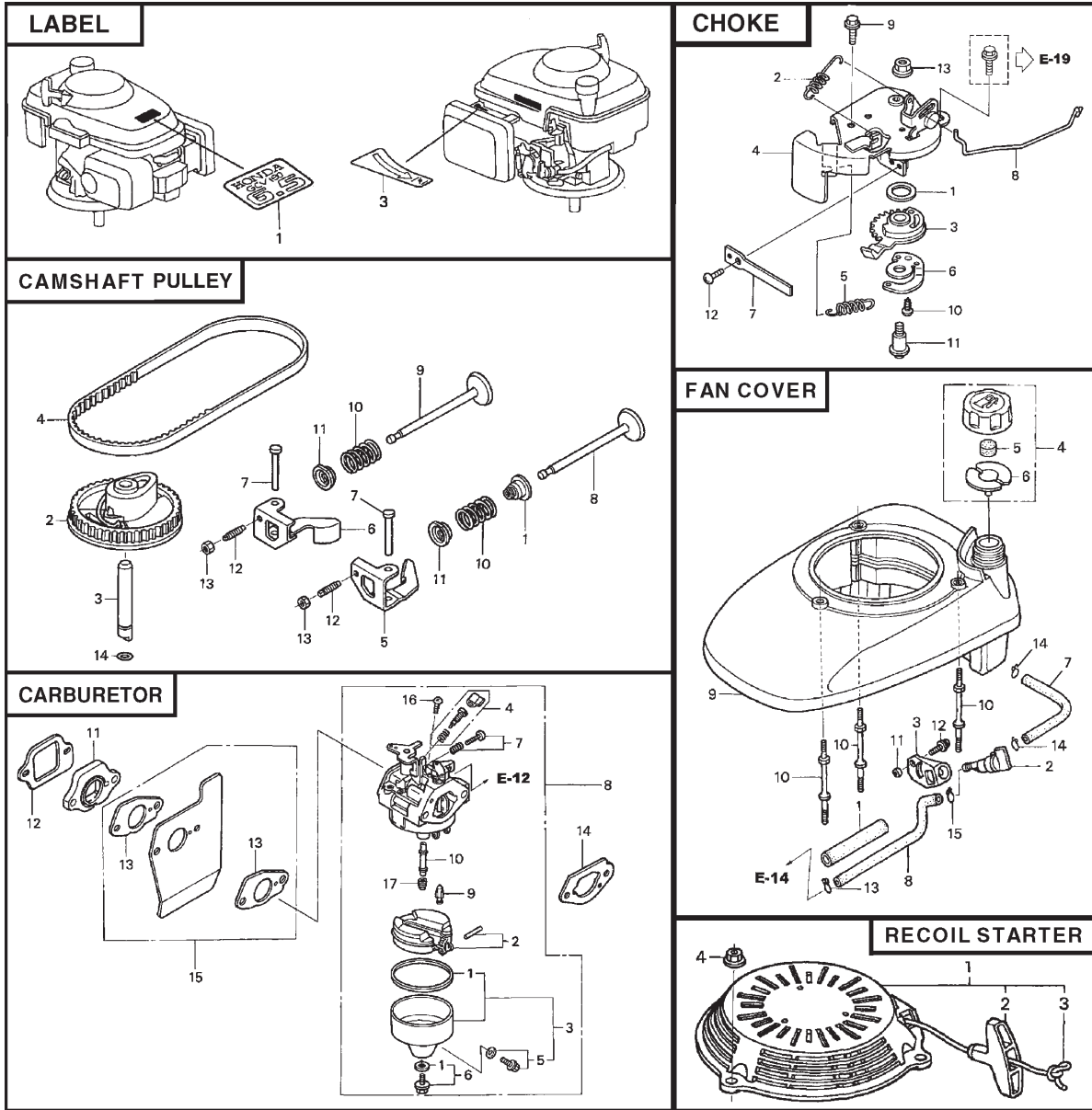

LABELS

KEY NO.	PART NO.	DESCRIPTION
1	7357650	Mark, Emblem (6.5)
3	7229917	Mark, Choke Indication

CHOKE

KEY NO.	PART NO.	DESCRIPTION
1	7257157	Seal, Choke Lever
2	4209581	Spring, Cable Return
3	7257165	Lever, Choke
4	7257173	Base, Choke
5	7257181	Spring, Choke Lever
6	7257199	Hook, Choke Spring
7	7257207	Plate, Choke
8	7229867	Rod, Stop
9	0671552	Bolt, Flange (#6 x 20) (CT200)
10	3674413	Screw, Tapping (#4 x 8) (Po)
11	2544690	Screw, Pan (#5 x 19)
12	0369017	Screw, Pan (#4 x 8)
13	0636951	Nut, Hex, Flange (5 mm)

CAMSHAFT PULLEY

KEY NO.	PART NO.	DESCRIPTION
1	6839831	Seal, Valve Stem
2	7357346	Pulley, Cam
3	5580063	Shaft, Cam Pulley
4	7058985	Belt, Timing (84HU7 G-200)
5	5580089	Rocker Arm, Intake Valve
6	5580097	Rocker Arm, Exhaust Valve
7	5580105	Shaft, Rocker Arm
8	5580113	Valve, Intake
9	5580121	Valve, Exhaust
10	5580139	Spring, Valve
11	1426980	Retainer, Intake Valve Spring
12	0294819	Screw, Tappet Adjusting
13	0004598	Nut, Tappet Adjusting
14	6315873	O-Ring (6.8 x 1.9)

FAN COVER

KEY NO.	PART NO.	DESCRIPTION
1	3683646	Rubber, Supporter (107 mm)
2	7357379	Petcock Assembly
3	5189352	Bracket, Petcock
4	6673289	Cap Assembly, Fuel Tank
5	7204506	Sponge, Fuel Cap Breather
6	7204514	Gasket, Fuel Cap
7	6754279	Tube, Fuel Tank
8	5580469	Tube, Fuel
9	7229875	Cover, Fan "NH1" (Black)
	7357411	Cover, Fan "R280" (Power Red)
10	5581004	Bolt, Stud
11	6978399	Collar, Fuel Petcock
12	0671636	Screw, Washer Head (#5 x 10)
13	0250647	Clip, Tube (B8)
14	0250985	Clip, Tube (B10)
15	0053447	Clip, Tube (C9)

CARBURETOR

KEY NO.	PART NO.	DESCRIPTION
1	3088416	Gasket Set
2	5580162	Float Set
3	3465879	Chamber Set, Float
4	4481818	Screw Set
5	1672187	Screw Set, Drain
6	1441518	Screw Set B
7	5580170	Screw Set
8	7357353	Carburetor Assembly (BB62KA)
9	5580212	Valve, Float
10	7357361	Nozzle, Main
11	5580238	Insulator, Carburetor
12	5580246	Gasket, Insulator
13	4581120	Gasket, Carburetor
14	5580253	Gasket, Carburetor(Choke Side)
15	5580535	Guide, Air
16	0639419	Screw, Pan (#5 x 6)
17	0636126	Jet, Main (#65)
	0636134	Jet, Main (#68)
	0636142	Jet, Main (#70)

RECOIL STARTER

KEY NO.	PART NO.	DESCRIPTION
1	7357437	Starter Assembly, Recoil "R280" (Power Red)
	7357445	Starter Assembly, Recoil "NH1" (Black)
2	5580634	Knob, Recoil Starter
3	5580642	Rope, Recoil Starter (#3.5 x 90")
4	6478812	Nut, Flange (6 mm)

Get it fixed, at your home or ours!

Just Call:

1-800-4-MY-HOME®

(1-800-469-4663)

24 hours a day, 7 days a week

For the repair of major brand appliances **in your own home...**
no matter who made it, no matter who sold it!

For your nearest **Sears Parts and Service** location,
to bring in products like vacuums, lawn equipment and electronics.

For **Sears Parts & Service**, to order the replacement parts,
accessories and owner's manuals that you need to do-it-yourself.

www.sears.ca

To purchase or inquire about a Sears Maintenance Agreement, call:

1-800-361-6665

9 a.m. – 11 p.m. Mon. – Fri., EST, 9 a.m. – 4 p.m. Sat.

Pour service en français:

1-800-LE-FOYER^{MC}

(1-800-533-6937)

www.sears.ca



® / TM Trademarks of Sears, Roebuck and Co. used under license by Sears Canada

^{MD} Marque déposée / ^{MC} Marque de commerce de Sears, Roebuck and Co. utilisée en vertu d'une licence de Sears Canada