

Owner's Manual



ROTARY LAWN MOWER

6.75 Horsepower

Power-Propelled

21" Multi-Cut

Model No.

944.365890

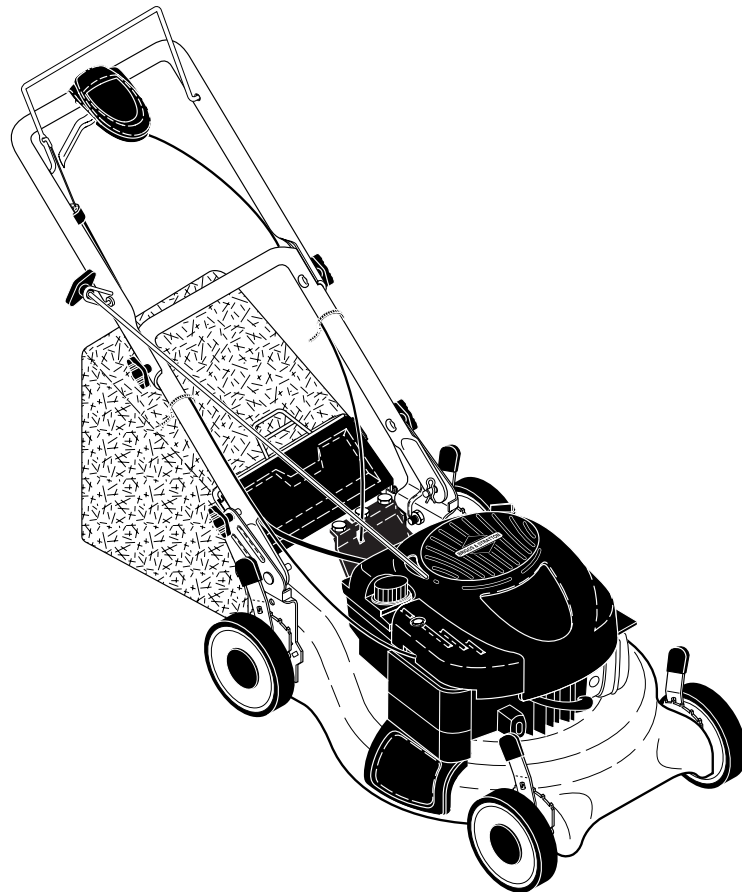

CAUTION:

Read and follow all
Safety Rules and Instructions
before operating this equipment

Sears Canada, Inc., Toronto, Ontario M5B 2B8

TABLE OF CONTENTS

Warranty	2	Maintenance	11-14
Safety Rules	2-3	Service and Adjustments.....	14-15
Product Specifications	4	Storage	16-17
Assembly/Pre-Operation	5	Troubleshooting	18-19
Operation.....	6-10	Repair Parts.....	20-27
Maintenance Schedule	11	Sears Service	Back Cover

WARRANTY

LIMITED TWO YEAR WARRANTY ON CRAFTSMAN POWER MOWER

For Two years from date of purchase Sears Canada, Inc. will repair or replace at Sears option free of charge parts which are defective as a result of material or workmanship.

COMMERCIAL OR RENTAL USE:

Warranty on Power Mower (Gas) will be ninety (90) days from date of purchase if used for commercial or rental purposes.

This Warranty does NOT cover:

- Pre-delivery set-up.
- In-home service
- Expendable items which become worn during normal use, such as rotary mower blades, blade adapters, belts, air cleaners and spark plug.
- Repairs necessary because of operator abuse or negligence, including bent crankshafts and the failure to maintain the equipment according to the instructions contained in the owner's manual.

Warranty service is available by returning the Craftsman Power Mower to the nearest Sears Service Centre/Department in Canada. This warranty applies only while this product is used in Canada.

This warranty is in addition to any statutory warranty and does not exclude or limit legal rights you may have but shall run concurrently with applicable provincial legislation. Furthermore, some provinces do NOT allow limitation on how long an implied warranty will last so the above limitations may not apply to you.

Sears Canada, Inc., Toronto, Ontario M5B 2B8

SAFETY RULES

IMPORTANT: This cutting machine is capable of amputating hands and feet and throwing objects. Failure to observe the following safety instructions could result in serious injury or death.

⚠ Look for this symbol to point out important safety precautions. It means **CAUTION!!! BECOME ALERT!!! YOUR SAFETY IS INVOLVED.**

⚠ WARNING: In order to prevent accidental starting when setting up, transporting, adjusting or making repairs, always disconnect spark plug wire and place wire where it cannot come in contact with plug.

⚠ CAUTION: Muffler and other engine parts become extremely hot during operation and remain hot after engine has stopped. To avoid severe burns on contact, stay away from these areas.

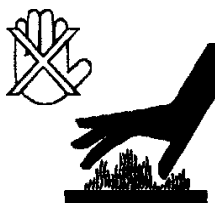

I. GENERAL OPERATION

- Read, understand, and follow all instructions on the machine and in the manual(s) before starting. Be thoroughly familiar with the controls and the proper use of the machine before starting.
- Do not put hands or feet near or under rotating parts. Keep clear of the discharge opening at all times.
- Only allow responsible individuals, who are familiar with the instructions, to operate the machine.
- Clear the area of objects such as rocks, toys, wire, bones, sticks, etc., which could be picked up and thrown by blade.
- Be sure the area is clear of other people before mowing. Stop machine if anyone enters the area.
- Do not operate the mower when bare-foot or wearing open sandals. Always wear substantial foot wear.

- Do not pull mower backwards unless absolutely necessary. Always look down and behind before and while moving backwards.
- Never direct discharged material toward anyone. Avoid discharging material against a wall or obstruction. Material may ricochet back toward the operator. Stop the blade when crossing gravel surfaces.
- Do not operate the mower without proper guards, plates, grass catcher or other safety protective devices in place.
- See manufacturer's instructions for proper operation and installation of accessories. Only use accessories approved by the manufacturer.
- Stop the blade(s) when crossing gravel drives, walks, or roads.
- Stop the engine (motor) whenever you leave the equipment, before cleaning the mower or unclogging the chute.
- Shut the engine (motor) off and wait until the blade comes to complete stop before removing grass catcher.
- Mow only in daylight or good artificial light.
- Do not operate the machine while under the influence of alcohol or drugs.
- Never operate machine in wet grass. Always be sure of your footing: keep a firm hold on the handle; walk, never run.
- Disengage the self-propelled mechanism or drive clutch on mowers so equipped before starting the engine.
- If the equipment should start to vibrate abnormally, stop the engine (motor) and check immediately for the cause. Vibration is generally a warning of trouble.
- Always wear safety goggles or safety glasses with side shields when operating mower.

II. SLOPE OPERATION

Slopes are a major factor related to slip & fall accidents which can result in severe injury. All slopes require extra caution. If you feel uneasy on a slope, do not mow it.

DO:

- Mow across the face of slopes: never up and down. Exercise extreme caution when changing direction on slopes.
- Remove obstacles such as rocks, tree limbs, etc.
- Watch for holes, ruts, or bumps. Tall grass can hide obstacles.

DO NOT:

- Do not trim near drop-offs, ditches or embankments. The operator could lose footing or balance.

- Do not trim excessively steep slopes.
- Do not mow on wet grass. Reduced footing could cause slipping.

III. CHILDREN

Tragic accidents can occur if the operator is not alert to the presence of children. Children are often attracted to the machine and the mowing activity. *Never* assume that children will remain where you last saw them.

- Keep children out of the trimming area and under the watchful care of another responsible adult.
- Be alert and turn machine off if children enter the area.
- Before and while walking backwards, look behind and *down* for small children.
- Never allow children to operate the machine.
- Use extra care when approaching blind corners, shrubs, trees, or other objects that may obscure vision.

IV. SAFE HANDLING OF GASOLINE

Use extreme care in handling gasoline. Gasoline is extremely flammable and the vapors are explosive.

- Extinguish all cigarettes, cigars, pipes and other sources of ignition.
- Use only an approved container.
- Never remove gas cap or add fuel with the engine running. Allow engine to cool before refueling.
- Never refuel the machine indoors.
- Never store the machine or fuel container where there is an open flame, spark or pilot light such as a water heater or on other appliances.
- Never fill containers inside a vehicle, on a truck or trailer bed with a plastic liner. Always place containers on the ground away from your vehicle before filling.
- Remove gas-powered equipment from the truck or trailer and refuel it on the ground. If this is not possible, then refuel such equipment with a portable container, rather than from a gasoline dispenser nozzle.
- Keep the nozzle in contact with the rim of the fuel tank or container opening at all times until fueling is complete. Do not use a nozzle lock-open device.
- If fuel is spilled on clothing, change clothing immediately.
- Never overfill fuel tank. Replace gas cap and tighten securely.

V. GENERAL SERVICE

- Never run machine inside a closed area.
- Never make adjustments or repairs with the engine (motor) running. Disconnect the spark plug wire, and keep the wire away from the plug to prevent accidental starting.
- Keep nuts and bolts, especially blade attachment bolts, tight and keep equipment in good condition.
- Never tamper with safety devices. Check their proper operation regularly.
- Keep machine free of grass, leaves, or other debris build-up. Clean oil or fuel spillage. Allow machine to cool before storing.
- Stop and inspect the equipment if you strike an object. Repair, if necessary, before restarting.
- Never attempt to make wheel height adjustments while the engine is running.
- Grass catcher components are subject to wear, damage, and deterioration, which could expose moving parts or allow objects to be thrown. Frequently check components and replace with manufacturer's recommended parts, when necessary.
- Mower blades are sharp and can cut. Wrap the blade(s) or wear gloves, and use extra caution when servicing them.
- Do not change the engine governor setting or overspeed the engine.
- Maintain or replace safety and instruction labels, as necessary.

⚠ WARNING: This lawn mower is equipped with an internal combustion engine and should not be used on or near any unimproved forest-covered, brush-covered or grass-covered land unless the engine's exhaust system is equipped with a spark arrester meeting applicable local or state laws (if any). If a spark arrester is used, it should be maintained in effective working order by the operator. A spark arrester for the muffler is available through your nearest Sears Service Centre (See the REPAIR PARTS section of this manual).

PRODUCT SPECIFICATIONS

Serial Number:

Date of Purchase:

Gasoline Capacity / Type: 1,5 Litres (Unleaded Regular)

Oil Capacity: 0,58 Litres

Oil Type (API SG–SL): SAE 30 (above 0°C/32°F); SAE 5W-30 (below 0°C/32°F)

Spark Plug: Champion RJ19LM (Gap: 0,76 mm)

Blade Bolt Torque: 35-40 ft. lbs. (47-54 N-m)

- The model and serial numbers will be found on a decal on the rear of the lawn mower housing. Record both serial number and date of purchase in space provided above.

ASSEMBLY / PRE-OPERATION

Read these instructions and this manual in its entirety before you attempt to assemble or operate your new lawn mower.

IMPORTANT: This lawn mower is shipped WITHOUT OIL OR GASOLINE in the engine. Your new lawn mower has been assembled at the factory with the exception of those parts left unassembled for shipping purposes. All parts such as nuts, washers, bolts, etc., necessary to complete the assembly have been placed in the parts bag. To ensure safe and proper operation of your lawn mower, all parts and hardware you assemble must be tightened securely. Use the correct tools as necessary to ensure proper tightness.

TO REMOVE MOWER FROM CARTON

1. Remove loose parts included with mower.
2. Cut down two end corners of carton and lay end panel down flat.
3. Remove all packing materials except padding between upper and lower handle and padding holding operator presence control bar to upper handle.
4. Roll mower out of carton and check carton thoroughly for additional loose parts.

HOW TO SET UP YOUR MOWER TO UNFOLD HANDLE

IMPORTANT: Unfold handle carefully so as not to pinch or damage control cables.

1. Raise lower handle section to operating position and align hole in handle with one of three height positioning holes.
2. Insert handle bolt through handle and bracket and secure with knob.
3. Repeat for opposite side of handle.
4. Remove protective padding, raise upper handle section into place on lower handle and tighten both handle knobs.
5. Remove any packing material from around control bar.

Your lawn mower handle can be adjusted for your mowing comfort. Refer to "ADJUST HANDLE" in the Service and Adjustments section of this manual.

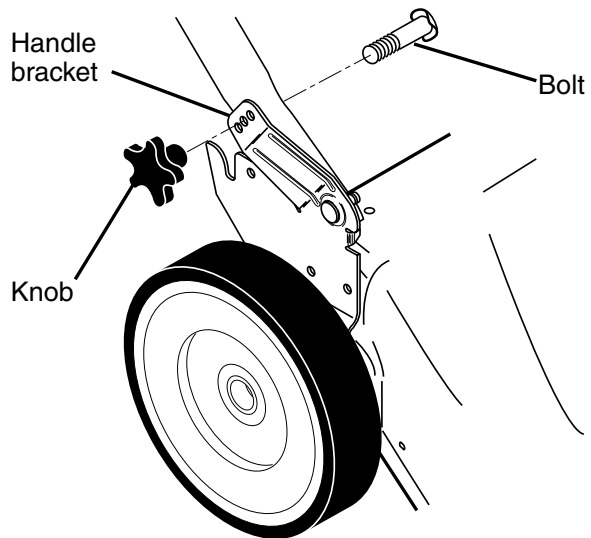
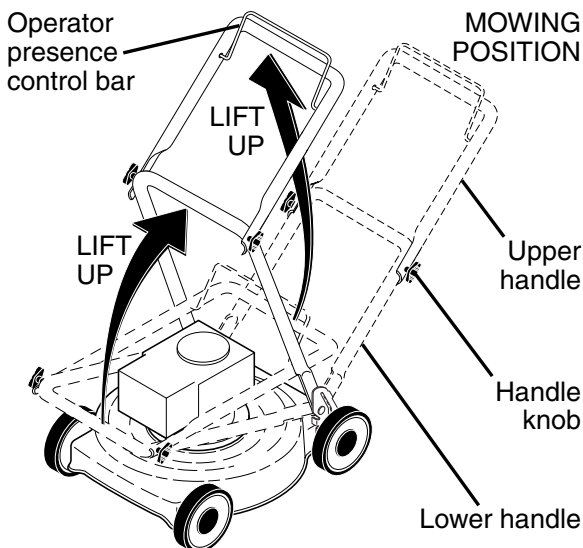

TO ASSEMBLE GRASS CATCHER

1. Put grass catcher frame into grass bag with rigid part of bag on the bottom. Make sure the frame handle is outside of the bag top.
2. Slip vinyl bindings over frame.

NOTE: If vinyl bindings are too stiff, hold them in warm water for a few minutes. If bag gets wet, let it dry before using.

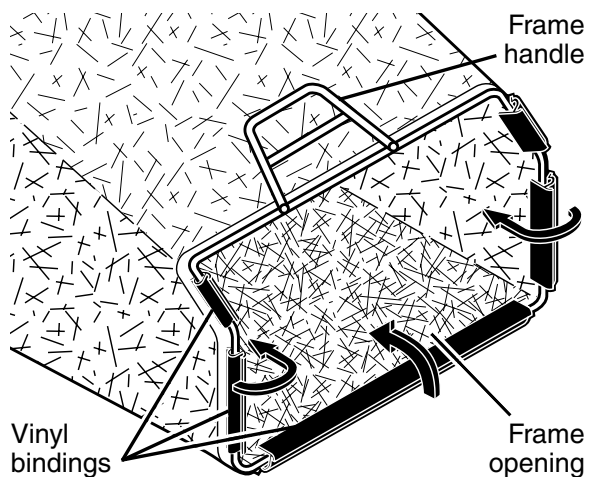

TO INSTALL ATTACHMENTS

Your lawn mower was shipped ready to be used as a mulcher. To convert to bagging, see "TO CONVERT MOWER" in the Operation section of this manual.

OPERATION

KNOW YOUR LAWN MOWER

READ THIS OWNER'S MANUAL AND ALL SAFETY RULES BEFORE OPERATING YOUR LAWN MOWER. Compare the illustrations with your lawn mower to familiarize yourself with the location of various controls and adjustments. Save this manual for future reference.

These symbols may appear on your lawn mower or in literature supplied with the product. Learn and understand their meaning.

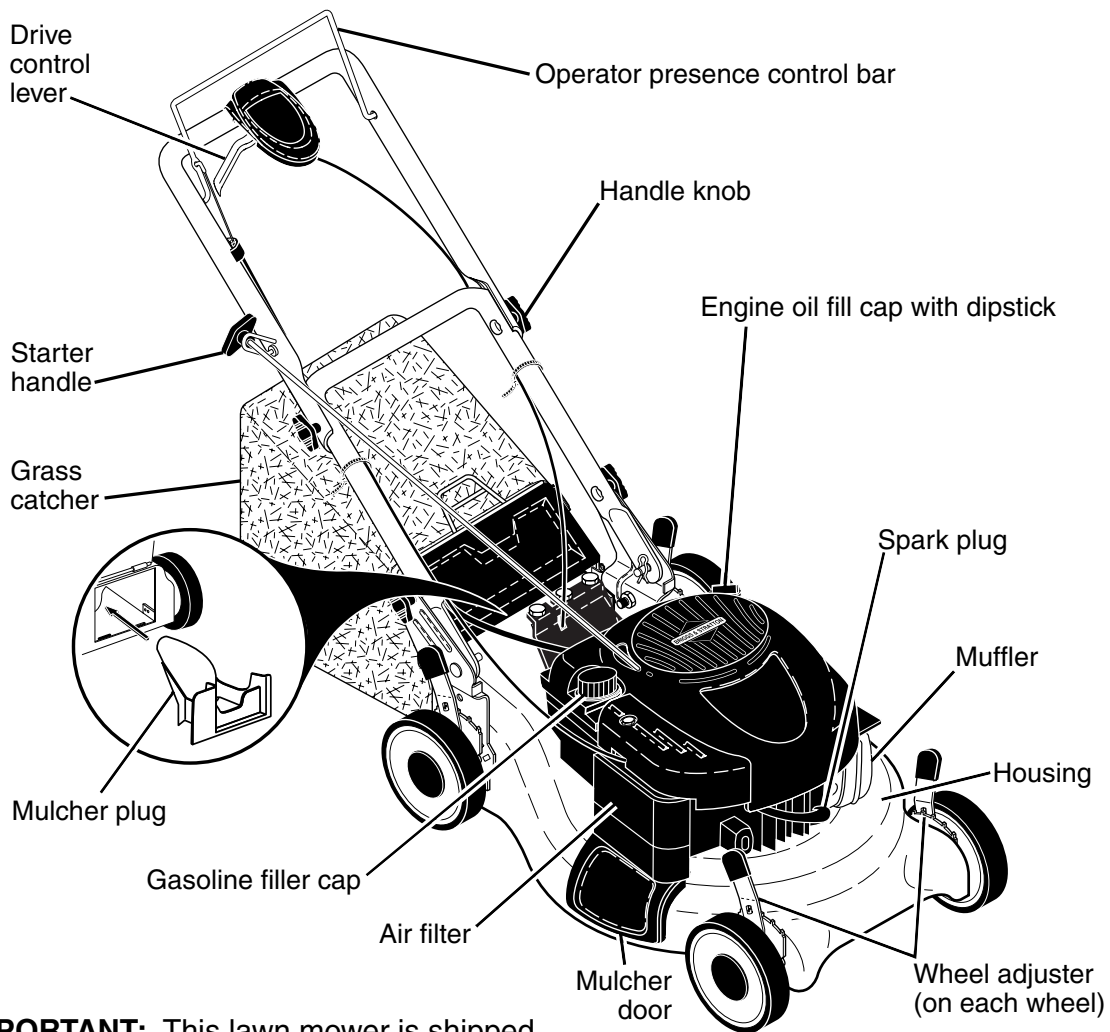
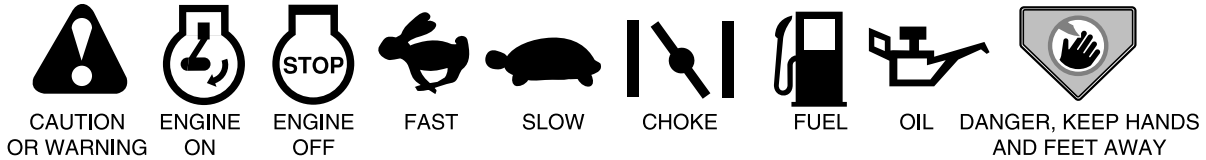

IMPORTANT: This lawn mower is shipped WITHOUT OIL OR GASOLINE in the engine.

MEETS CPSC SAFETY REQUIREMENTS

Sears rotary walk-behind power lawn mowers conform to the safety standards of the American National Standards Institute and the U.S. Consumer Product Safety Commission. The blade turns when the engine is running.

Operator presence control lever – must be held down to the handle to start the engine. Release to stop the engine.

Drive control bar – used to engage power-propelled forward motion of mower.

Starter handle – used for starting engine. 6

Mulcher door – allows conversion to discharging or bagging operation.

Mulcher plug – located at the rear discharge opening. Must be removed when converting to bagging operation.



The operation of any lawn mower can result in foreign objects thrown into the eyes, which can result in severe eye damage. Always

wear safety glasses or eye shields while operating your lawn mower or performing any adjustments or repairs. We recommend standard safety glasses or a wide vision safety mask worn over spectacles.

HOW TO USE YOUR LAWN MOWER ENGINE SPEED

The engine speed was set at the factory for optimum performance. Speed is not adjustable.

ENGINE ZONE CONTROL

CAUTION: Federal regulations require an engine control to be installed on this lawn mower in order to minimize the risk of blade contact injury. Do not under any circumstances attempt to defeat the function of the operator control. The blade turns when the engine is running.

- Your lawn mower is equipped with an operator presence control bar which requires the operator to be positioned behind the lawn mower handle to start and operate the lawn mower.

DRIVE CONTROL

- Self-propelling is controlled by holding the operator presence control bar down to the handle and pulling the drive control lever rearward to the handle. The farther toward the handle the lever is pulled, the faster the unit will travel.
- Forward motion will stop when either the operator presence control bar or drive control lever are released. To stop forward motion without stopping engine, release the drive control lever only. Hold operator presence control bar down against handle to continue mowing without self-propelling.

NOTE: If after releasing the drive control the mower will not roll backwards, push the mower forward slightly to disengage drive wheels.

DRIVE CONTROL ADJUSTMENT

Over time, the drive control system may become “loose”, resulting in decreased speed. There is a turnbuckle on the underside of the drive control housing to increase tension on the drive cable. Proceed as follows:

- Turn unit off and disconnect spark plug wire from spark plug.
- Turn nut on underside of drive control to increase drive speed.
- Operate mower to test drive speed. Readjust as required.

- If condition fails to improve after the above steps (forward speed remains the same), your drive belt is worn and should be replaced.

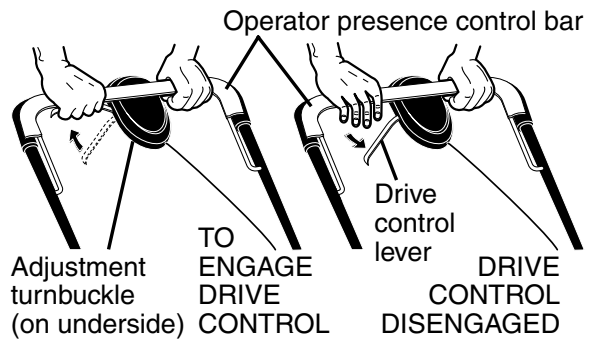

TO ADJUST CUTTING HEIGHT

Raise wheels for low cut and lower wheels for high cut, adjust cutting height to suit your requirements. Medium position is best for most lawns.

- To change cutting height, squeeze adjuster lever toward wheel. Move wheel up or down to suit your requirements. Be sure all wheels are in the same setting.

NOTE: Adjuster is properly positioned when plate tab inserts into hole in lever. Also, 9-position adjusters (if so equipped) allow lever to be positioned between the plate tabs.

LEVER BACKWARD TO LOWER MOWER

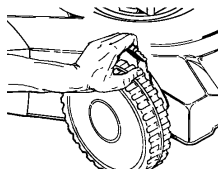
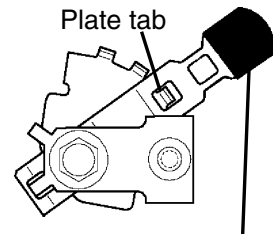

Plate tab



LEVER FORWARD TO RAISE MOWER Lever

TO ATTACH GRASS CATCHER

- Lift the rear door of the lawn mower and place the grass catcher frame side hooks onto the door pivot pins.
- The grass catcher is secured to the lawn mower housing when the rear door is lowered onto the grass catcher frame.

CAUTION: Do not run your lawn mower without mulcher plug, clipping deflector or approved grass catcher in place. Never attempt to operate the lawn mower with the rear door removed or propped open.

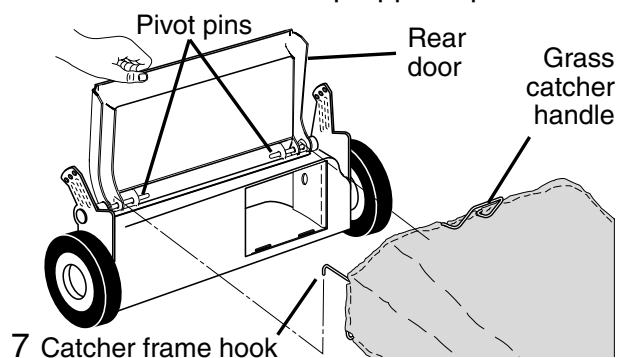

7 Catcher frame hook

TO EMPTY GRASS CATCHER

1. Lift up on grass catcher using the frame handle.
2. Remove grass catcher with clippings from under lawn mower handle.
3. Empty clippings from bag.

NOTE: Do not drag the bag when emptying; it will cause unnecessary wear.

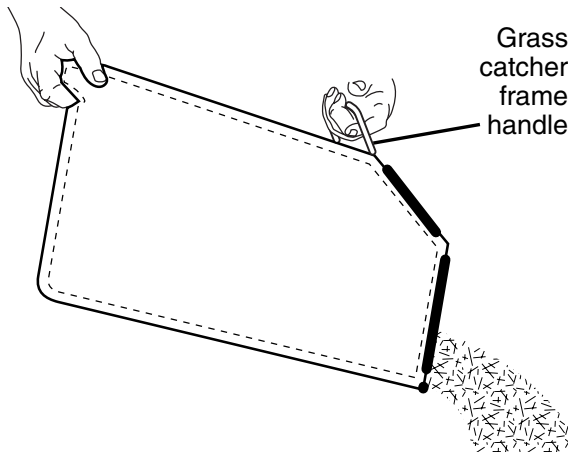

TO CONVERT MOWER

Your lawn mower was shipped ready to be used as a mulcher. To convert to bagging or discharging:

REAR BAGGING

- Open rear door and remove mulcher plug. Store mulcher plug in a safe place.
- You can now install the grass catcher or optional clipping deflector.
- To convert to mulching or discharging operation, install mulcher plug into rear discharge opening of mower.

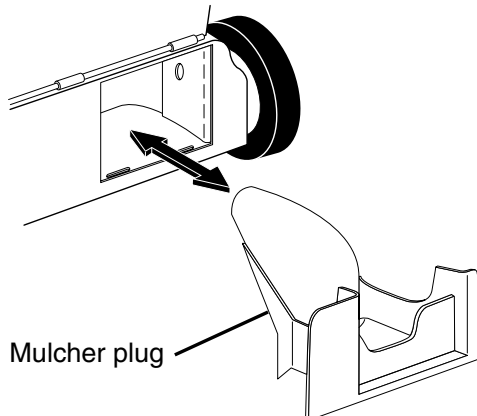

SIDE DISCHARGING

- Mulcher plug must be installed into rear discharge opening of mower.
- Open mulcher door and install discharge deflector under door as shown.
- Mower is now ready for discharging operation.
- To convert to mulching or bagging operation, discharge deflector must be removed and mulcher door closed.

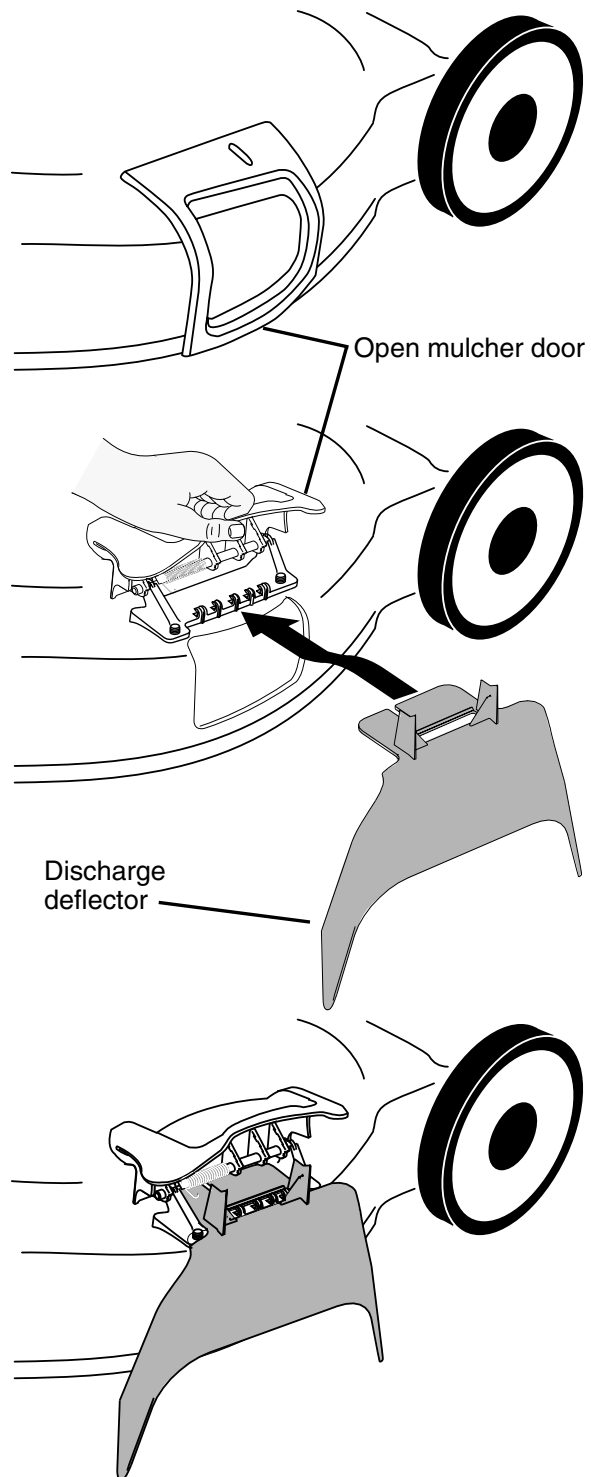

SIMPLE STEPS TO REMEMBER WHEN CONVERTING YOUR LAWN MOWER

FOR MULCHING -

1. Rear mulcher plug installed.
2. Mulcher door closed.

FOR REAR BAGGING -

1. Rear mulcher plug removed.
2. Grass catcher installed.
3. Mulcher door closed.

FOR SIDE DISCHARGING -

1. Rear mulcher plug installed.
2. Discharge deflector installed.

CAUTION: Do not run your lawn mower without mulcher plug, clipping deflector or approved grass catcher in place. Never attempt to operate the lawn mower with the rear door removed or propped open.

BEFORE STARTING ENGINE

ADD OIL

Your lawnmower is shipped without oil in the engine. For type and grade of oil to use, see “ENGINE” in the Maintenance section of this manual.

CAUTION: DO NOT overfill engine with oil, or it will smoke heavily from the muffler on startup.

1. Be sure lawnmower is level.
2. Remove oil dipstick from oil fill spout.
3. You receive a container of oil with the unit. Slowly pour the entire container down the oil fill spout into the engine.

NOTE: Initial oil fill requires only 18 oz. due to residual oil in engine from the manufacturer's 100% quality testing. When changing oil you may need 20 oz.

4. Insert and tighten dipstick.

IMPORTANT:

- Check oil level before each use. Add oil if needed. Fill to full line on dipstick.
- Change the oil after every 25 hours of operation or each season. You may need to change the oil more often under dusty, dirty conditions. See “TO CHANGE ENGINE OIL” in the Maintenance section of this manual.

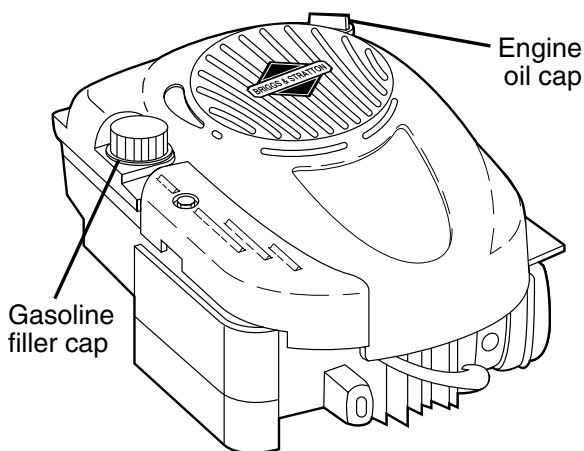

ATTACH FUEL CAP CARTRIDGE

Your mower is equipped with a special *FRESH START™* fuel cap and continuous fuel preserver cartridge. See the information and instructions packed with the *FRESH START™* cartridge.

1. Snap cartridge into bottom of fuel cap.

NOTE: Do not remove the silver foil seal on the side of cartridge that snaps into fuel cap.

2. Grasp the white peel tab and pull to remove the entire seal.
3. Screw fuel cap onto fuel tank after filling tank with gasoline.

Replace cartridge when empty (about once a season). Check preserver level visually.

DANGER: Cartridge fluid is HARMFUL OR FATAL IF SWALLOWED. Avoid contact to eyes, skin, or clothing. Do not take internally. Do not inhale fluid vapor. Keep out of reach of children. If swallowed, call a physician immediately.

ADD GASOLINE

- Fill fuel tank to bottom of tank filler neck. Do not overfill. Use fresh, clean, regular unleaded gasoline with a minimum of 87 octane. Do not mix oil with gasoline. Purchase fuel in quantities that can be used within 30 days to assure fuel freshness.

CAUTION: Wipe off any spilled oil or fuel. Do not store, spill or use gasoline near an open flame.

CAUTION: Alcohol blended fuels (called gasohol or using ethanol or methanol) can attract moisture which leads to separation and formation of acids during storage. Acidic gas can damage the fuel system of an engine while in storage. To avoid engine problems, the fuel system should be emptied before storage of 30 days or longer. Empty the gas tank, start the engine and let it run until the fuel lines and carburetor are empty. Use fresh fuel next season. See Storage Instructions for additional information. Never use engine or carburetor cleaner products in the fuel tank or permanent damage may occur.

TO STOP ENGINE

- To stop engine, release operator presence control bar.

TO START ENGINE

NOTE: Due to protective coatings on the engine, a small amount of smoke may be present during the initial use of the product and should be considered normal.

NOTE: Your engine is equipped with an automatic choke system. No priming or choking is required before starting.

- To start engine, hold operator presence control bar down to the handle and pull starter handle quickly. Do not allow starter rope to snap back.

MOWING TIPS

⚠ CAUTION: Do not use de-thatcher blade attachments on your mower. Such attachments are hazardous, will damage your mower and could void your warranty.

- Under certain conditions, such as very tall grass, it may be necessary to raise the height of cut to reduce pushing effort and to keep from overloading the engine and leaving clumps of grass clippings. It may also be necessary to reduce ground speed and/or run the lawn mower over the area a second time.
- For extremely heavy cutting, reduce the width of cut by overlapping previously cut path and mow slowly.
- For better grass bagging and most cutting conditions, the engine speed should be set in the FAST position.
- Pores in cloth grass catchers can become filled with dirt and dust with use and catchers will collect less grass. To prevent this, regularly hose catcher off with water and let dry before using.
- Keep top of engine around starter clear and clean of grass clippings and chaff. This will help engine air flow and extend engine life.

MULCHING MOWING TIPS

IMPORTANT: For best performance, keep mower housing free of built-up grass and trash. See “CLEANING” in the Maintenance section of this manual.

- The special mulching blade will recut the grass clippings many times and reduce them in size so that as they fall onto the lawn they will disperse into the grass and not be noticed. Also, the mulched grass will biodegrade quickly to provide nutrients for the lawn. Always mulch with your highest engine (blade) speed as this will provide the best recutting action of the blades.
- Avoid cutting your lawn when it is wet. Wet grass tends to form clumps and interferes with the mulching action. The best time to mow your lawn is the early afternoon. At this time the grass has dried, yet the newly cut area will not be exposed to direct sunlight.
- For best results, adjust the lawn mower cutting height so that the lawn mower cuts off only the top one-third of the grass blades. If the lawn is overgrown it will be necessary to raise the height of cut to reduce pushing effort and to keep from overloading the engine and leaving clumps of mulched grass. For extremely heavy grass, reduce your width of cut by overlapping previously cut path and mow slowly.



- Certain types of grass and grass conditions may require that an area be mulched a second time to completely hide the clippings. When doing a second cut, mow across (perpendicular) to the first cut path.
- Change your cutting pattern from week to week. Mow north to south one week then change to east to west the next week. This will help prevent matting and graining of the lawn.

MAINTENANCE

MAINTENANCE SCHEDULE		BEFORE EACH USE	AFTER EACH USE	EVERY 10 HOURS	EVERY 25 HOURS OR SEASON	EVERY 100 HOURS	BEFORE STORAGE
LAWN MOWER	Check for Loose Fasteners	✓					✓
	Clean / Inspect Grass Catcher *	✓	✓				✓
	Check Tires	✓					
	Check Drive Wheels ***	✓					
	Clean Lawn Mower ****		✓				✓
	Clean under Drive Cover ***			✓			
	Check Drive Belt / Pulleys ***				✓		
	Check / Sharpen / Replace Blade				✓ ₃		
ENGINE	Lubrication				✓		
	Clean and Recharge Battery **				✓		✓ ₄
	Check Engine Oil level	✓ ₅					
	Change Engine Oil				✓ _{1,2}		
	Clean Air Filter				✓ ₂		
	Inspect Muffler				✓		
	Replace Spark Plug					✓	
	Replace Air Filter Paper Cartridge					✓ ₂	
Empty fuel system or add Stabilizer						✓	

- * (if so equipped)
- ** Electric-Start mowers
- *** Power-Propelled mowers
- **** Use a scraper to clean under deck
- 1 - Change more often if operating under a heavy load or in high outdoor temperatures.
- 2 - Service more often if operating in dirty or dusty conditions.
- 3 - Replace blades more often when mowing in sandy soil.
- 4 - Charge 48 hours at end of season.
- 5 - And after each 5 hours of use.

GENERAL RECOMMENDATIONS

The warranty on this lawn mower does not cover items that have been subjected to operator abuse or negligence. To receive full value from the warranty, operator must maintain unit as instructed in this manual.

Some adjustments will need to be made periodically to properly maintain your unit.

At least once a season, check to see if you should make any of the adjustments described in the Service and Adjustments section of this manual.

- At least once a year, replace the spark plug, clean or replace air filter element and check blade for wear. A new spark plug and clean/new air filter element assure proper air-fuel mixture and help your engine run better and last longer.
- Follow the maintenance schedule in this manual.

BEFORE EACH USE

- Check engine oil level.
- Check for loose fasteners.

LUBRICATION

Keep unit well lubricated (See "LUBRICATION CHART").

LUBRICATION CHART

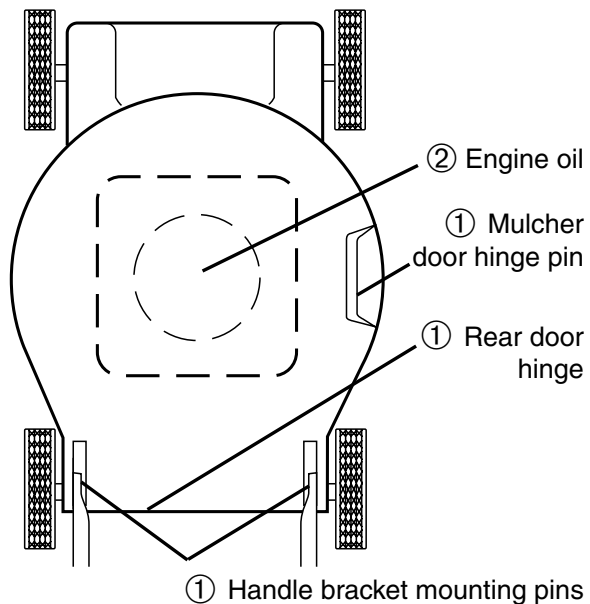

- ① Spray lubricant
- ② See "ENGINE" in Maintenance section.

IMPORTANT: Do not oil or grease plastic wheel bearings. Viscous lubricants will attract dust and dirt that will shorten the life of the self-lubricating bearings. If you feel they must be lubricated, use only a dry, powdered graphite type lubricant sparingly.

LAWN MOWER

Always observe safety rules when performing any maintenance.

TIRES

- Keep tires free of gasoline, oil, or insect control chemicals which can harm rubber.
- Avoid stumps, stones, deep ruts, sharp objects and other hazards that may cause tire damage.

DRIVE WHEELS

Check rear drive wheels each time you mow to be sure they move freely. The wheels not turning freely means trash, grass cuttings, etc., may be inside the drive wheel and dust cover area and must be cleaned out to free drive wheels. If necessary to clean the drive wheels, check both rear wheels.

BLADE CARE

For best results, blade must be kept sharp. Replace a bent or damaged blade.

⚠ CAUTION: Use only a replacement blade approved by the manufacturer of your mower. Using a blade not approved by the manufacturer of your mower is hazardous, could damage your mower and void your warranty.

TO REMOVE BLADE

1. Disconnect spark plug wire from spark plug and place wire where it cannot come in contact with plug.
2. Turn lawn mower on its side. Make sure air filter and carburetor are up.
3. Use a wood block between blade and mower housing to prevent blade from turning when removing blade bolt.

NOTE: Protect your hands with gloves and/or wrap blade with heavy cloth.

4. Remove blade bolt by turning counter-clockwise.
5. Remove blade and attaching hardware (bolt, lock washer, hardened washer).

NOTE: Remove the blade adapter and check the key inside hub of blade adapter. The key must be in good condition to work properly. Replace adapter if damaged.

TO REPLACE BLADE

1. Position the blade adapter on the engine crankshaft. Be sure key in adapter and crankshaft keyway are aligned.
2. Position blade on the blade adapter aligning the two (2) holes in the blade with the raised lugs on the adapter.
3. Be sure the trailing edge of blade (opposite sharp edge) is up toward the engine.
4. Install the blade bolt with the lock washer and hardened washer into blade adapter and crankshaft.

5. Use block of wood between blade and lawn mower housing and tighten the blade bolt, turning clockwise.

- The recommended tightening torque is 35-40 ft. lbs. / 47-54 N-m.

IMPORTANT: Blade bolt is heat treated. If bolt needs replacing, replace only with approved bolt shown in the Repair Parts section of this manual.

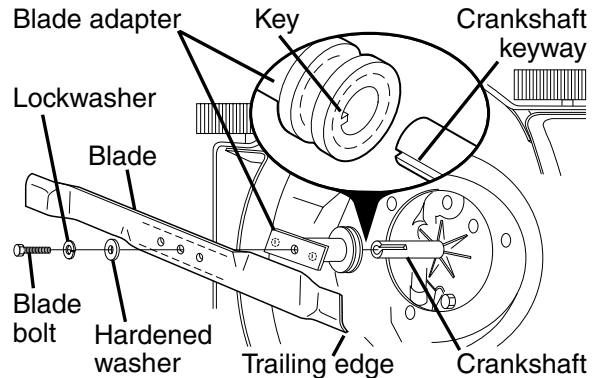

TO SHARPEN BLADE

NOTE: We do not recommend sharpening blade - but if you do, be sure the blade is balanced. Care should be taken to keep the blade balanced. An unbalanced blade will cause eventual damage to lawn mower or engine.

- The blade can be sharpened with a file or on a grinding wheel. Do not attempt to sharpen while on the mower.
- To check blade balance, drive a nail into a beam or wall. Leave about one inch of the straight nail exposed. Place center hole of blade over the head of the nail. If blade is balanced, it should remain in a horizontal position. If either end of the blade moves downward, sharpen the heavy end until the blade is balanced.

GRASS CATCHER

- The grass catcher may be hosed with water, but must be dry when used.
- Check your grass catcher often for damage or deterioration. Through normal use it will wear. If catcher needs replacing, replace only with approved replacement catcher shown in the Repair Parts section of this manual. Give the lawn mower model number when ordering.

GEAR CASE

- To keep your drive system working properly, the gear case and area around the drive should be kept clean and free of trash build-up. Clean under the drive cover twice a season.
- The gear case is filled with lubricant to the proper level at the factory. The only time the lubricant needs attention is if service has been performed on the gear case.

- If lubricant is required, use only Texaco Starplex Premium 1 Grease, Part No. 750369. Do not substitute.

ENGINE LUBRICATION

Use only high quality detergent oil rated with API service classification SG-SL. Select the oil's SAE viscosity grade according to your expected operating temperature.

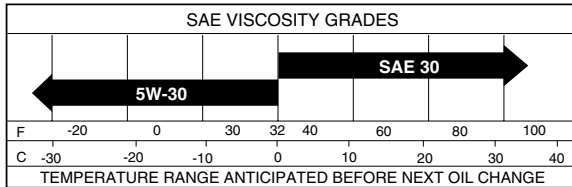

NOTE: Although multi-viscosity oils (5W30, 10W30 etc.) improve starting in cold weather, these multi-viscosity oils will result in increased oil consumption when used above 32°F. Check your engine oil level more frequently to avoid possible engine damage from running low on oil. Change the oil after every 25 hours of operation or at least once a year if the lawn mower is not used for 25 hours in one year.

Check the crankcase oil level before starting the engine and after each five (5) hours of continuous use. Tighten oil plug securely each time you check the oil level.

TO CHANGE ENGINE OIL

NOTE: Before tipping lawn mower to drain oil, empty fuel tank by running engine until fuel tank is empty.

1. Disconnect spark plug wire from spark plug and place wire where it cannot come in contact with plug.
2. Remove engine oil cap; lay aside on a clean surface.
3. Tip lawn mower on its side as shown and drain oil into a suitable container. Rock lawn mower back and forth to remove any oil trapped inside of engine.

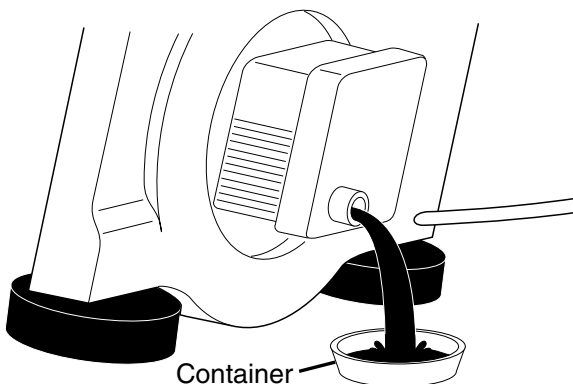

4. Wipe off any spilled oil from lawn mower or side of engine.

5. Slowly pour oil down the oil fill spout, stopping every few ounces to check the oil level with the dipstick.
6. Stop adding oil when you reach the FULL mark on the dipstick. Wait a minute to allow oil to settle.
7. Continue adding small amounts of oil, rechecking the dipstick until oil level settles at FULL. DO NOT overfill, or engine will smoke heavily from the muffler on startup.
8. Always be sure to retighten oil dipstick before starting engine.
9. Reconnect spark plug wire to plug.

AIR FILTER

Your engine will not run properly and may be damaged by using a dirty air filter. Replace the air filter cartridge every 100 hours of operation or every season, whichever occurs first. Service air cleaner more often under dusty conditions.

TO CLEAN AIR FILTER

1. Loosen screw and tilt cover to remove.
2. Carefully remove cartridge.
3. Clean by gently tapping on a flat surface. If very dirty, replace cartridge.

CAUTION: Petroleum solvents, such as kerosene, are not to be used to clean cartridge. They may cause deterioration of the cartridge. Do not oil cartridge. Do not use pressurized air to clean or dry cartridge.

4. Install cartridge, then replace cover making sure the tabs are aligned with the slots in the back plate. Fasten screw securely.

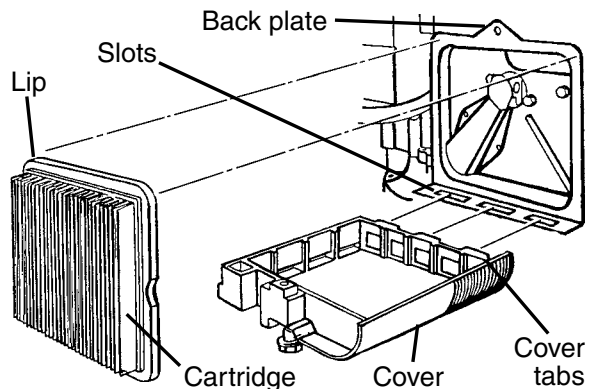

MUFFLER

Inspect and replace corroded muffler as it could create a fire hazard and/or damage.

SPARK PLUG

Replace spark plug at the beginning of each mowing season or after every 100 hours of operation, whichever occurs first. Spark plug type and gap setting are shown in the "PRODUCT SPECIFICATIONS" section of this manual.

CLEANING

IMPORTANT: For best performance, keep mower housing free of built-up grass and trash. Clean the underside of your mower after each use.

CAUTION: Disconnect spark plug wire from spark plug and place wire where it cannot come in contact with plug.

- Clean underside of mower by scraping to remove build-up of grass and trash.
- Clean engine often to keep trash from accumulating. A clogged engine runs hotter and shortens engine life.

- Keep finished surfaces and wheels free of all gasoline, oil, etc.
- We do not recommend using a garden hose to clean lawn mower unless the electrical system, muffler, air filter and carburetor are covered to keep water out. Water in engine can result in shortened engine life.

CLEAN UNDER DRIVE COVER

Clean under drive cover at least twice a season. Scrape underside of cover with putty knife or similar tool to remove any build-up of trash or grass on underside of drive cover.

SERVICE AND ADJUSTMENTS

WARNING: To avoid serious injury, before performing any service or adjustments:

1. Release control bar and stop engine.
2. Make sure the blade and all moving parts have completely stopped.
3. Disconnect spark plug wire from spark plug and place wire where it cannot come in contact with plug.

LAWN MOWER

TO ADJUST CUTTING HEIGHT

See "TO ADJUST CUTTING HEIGHT" in the Operation section of this manual.

REAR DEFLECTOR

The rear deflector, attached between the rear wheels of your mower, is provided to minimize the possibility that objects will be thrown out of the rear of the mower into the operator mowing position. If the deflector becomes damaged, it should be replaced.

TO REMOVE DRIVE BELT

1. Disconnect spark plug wire from spark plug and place wire where it cannot come in contact with plug.
2. Remove screws retaining drive cover (not shown); and remove drive cover from lawn mower housing.
3. Remove drive cable from anchor, then detach it and return spring from idler arm assembly.

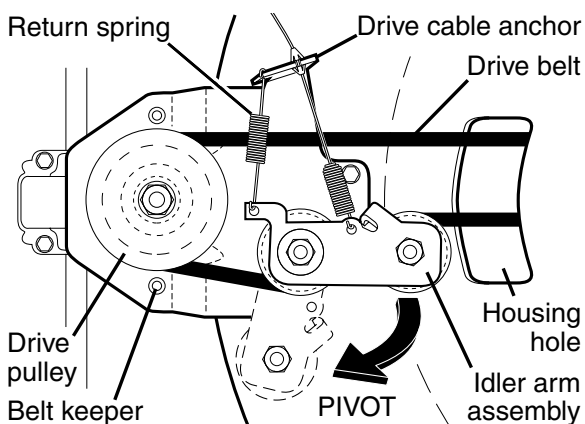

4. Remove idler arm assembly from housing by removing hex nut; then remove drive belt from drive pulley, belt keepers and idler arm assembly.
5. Turn lawn mower on its side. Make sure air filter and carburetor are up.
6. Remove screw securing debris shield. Note that the debris shield has a tab which fits into a gap in the housing.

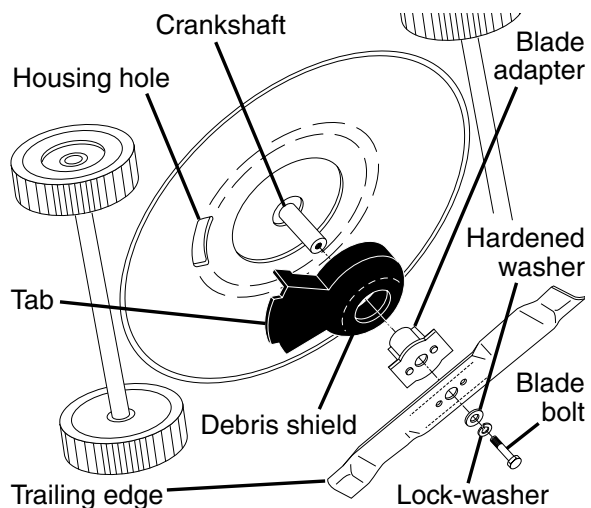

7. Use a wood block between blade and mower housing to prevent blade from turning when removing blade bolt.

NOTE: Protect your hands with gloves and/or wrap blade with heavy cloth.

8. Remove blade bolt.
9. Remove blade, attaching hardware (bolt, lock washer, hardened washer), blade adapter and debris shield. Note that the debris shield has a tab which fits into the housing hole.
10. Remove drive belt from engine pulley; discard old belt.

TO REPLACE DRIVE BELT

1. Place new drive belt on engine pulley.
2. Route the other end of the new drive belt through hole in housing.
3. Return mower to upright position.
4. Install new drive belt into idler arm assembly, then around the drive pulley. Be sure belt is inside of belt keepers.
5. Reattach idler arm assembly with hex nut previously removed.
6. Turn lawn mower on its side. Make sure air filter and carburetor are up.
7. Reattach debris shield to housing with tab of debris shield in housing hole.
8. Position blade on the blade adapter aligning the two (2) holes in the blade with the raised lugs on the adapter.
9. Be sure the trailing edge of blade (opposite sharp edge) is up toward the engine as shown.
10. Install the blade bolt with the lock washer and hardened washer into blade adapter and crankshaft.
11. Use block of wood between blade and lawn mower housing and tighten the blade bolt, turning clockwise.
 - The recommended tightening torque is 35-40 ft. lbs.
12. Return mower to upright position.
13. Reattach drive cable and return spring to the idler arm assembly, then reattach drive cable to anchor.
14. Reattach drive cover with screw(s) previously removed.
15. Connect spark plug wire to spark plug.

TO ADJUST HANDLE

The handle on your lawn mower has three (3) height positions - adjust to height that suits you.

1. Remove knob and carriage bolt on one side of the lower handle.
2. While holding handle assembly, remove knob and carriage bolt from opposite side, align hole in handle with desired hole in handle bracket and reassemble bolt and knob and tighten securely.

3. Align opposite side of handle with same positioning hole and secure with bolt and knob.

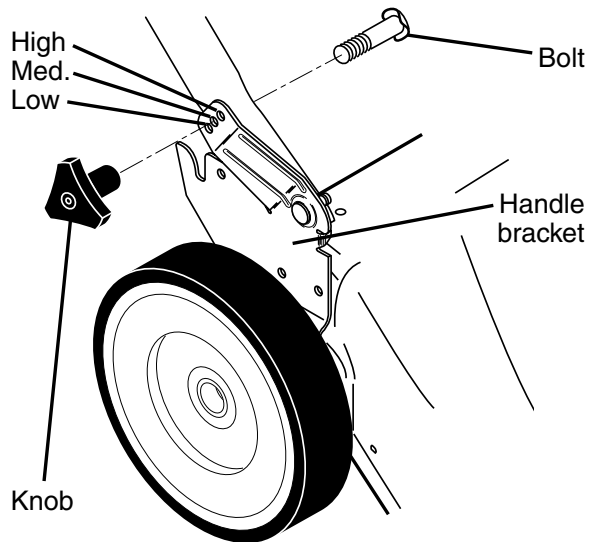

ENGINE ENGINE SPEED

Your engine speed has been factory set. Do not attempt to increase engine speed or it may result in personal injury. If you believe that the engine is running too fast or too slow, take your lawn mower to a Sears or other qualified service center for repair and adjustment.

CARBURETOR

Your carburetor is not adjustable. If your engine does not operate properly due to suspected carburetor problems, take your lawn mower to a Sears or other qualified service center for repair or adjustment.

IMPORTANT: Never tamper with the engine governor, which is factory set for proper engine speed. Overspeeding the engine above the factory high speed setting can be dangerous. If you think the engine-governed high speed needs adjusting, contact a Sears or other qualified service center, which has proper equipment and experience to make any necessary adjustments.

STORAGE

Immediately prepare your lawn mower for storage at the end of the season or if the unit will not be used for 30 days or more.

LAWN MOWER

When lawn mower is to be stored for a period of time, clean it thoroughly, remove all dirt, grease, leaves, etc. Store in a clean, dry area.

1. Clean entire lawn mower (See "CLEANING" in the Maintenance section of this manual).
2. Lubricate as shown in the Maintenance section of this manual.
3. Be sure that all nuts, bolts, screws, and pins are securely fastened. Inspect moving parts for damage, breakage and wear. Replace if necessary.
4. Touch up all rusted or chipped paint surfaces; sand lightly before painting.

HANDLE

You can fold your mower handle for storage.

1. Loosen the two (2) handle knobs on sides of the upper handle and allow handle to fold down to the rear.
 2. Remove the two (2) handle knobs and carriage bolts on sides of the lower handle and pivot entire handle assembly forward and allow it to rest on mower.
 3. Reinstall knobs and carriage bolts to lower handle or handle brackets for safe keeping.
- When setting up your handle from the storage position, the lower handle will require manually locking into the mowing position.

IMPORTANT: When folding the handle for storage or transportation, be sure to fold the handle as shown or you may damage the control cables.

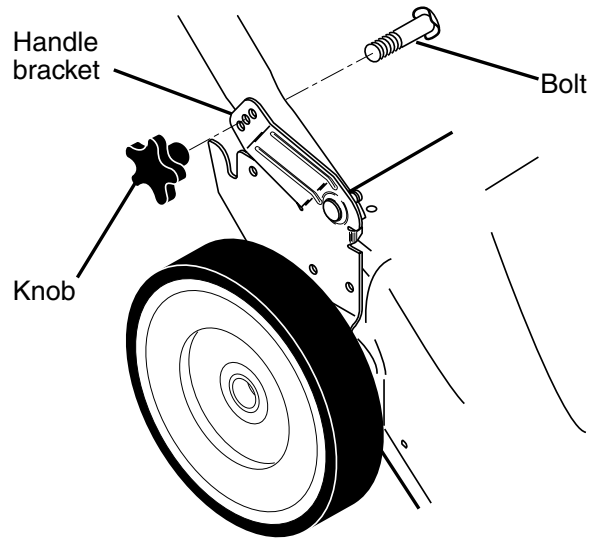
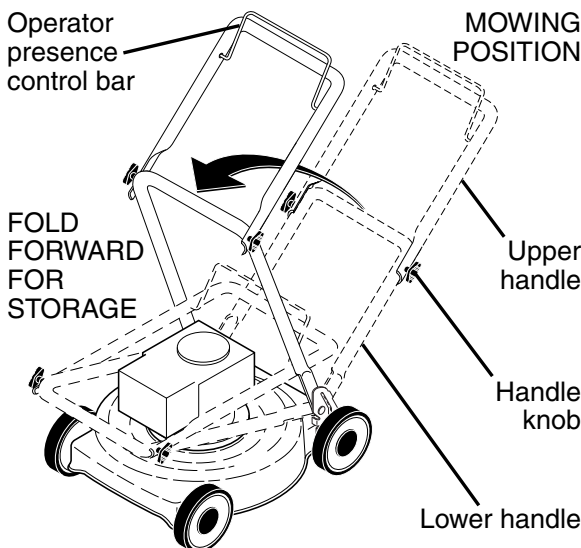

ENGINE

FUEL SYSTEM

IMPORTANT: It is important to prevent gum deposits from forming in essential fuel system parts such as carburetor, fuel filter, fuel hose or tank during storage. Alcohol blended fuels (called gasohol or using ethanol or methanol) can attract moisture which leads to separation and formation of acids during storage. Acidic gas can damage the fuel system of an engine while in storage.

- Empty the fuel tank by starting the engine and letting it run until the fuel lines and carburetor are empty.
- Never use engine or carburetor cleaner products in the fuel tank or permanent damage may occur.
- Use fresh fuel next season.

NOTE: Fuel stabilizer is an acceptable alternative in minimizing the formation of fuel gum deposits during storage. Add stabilizer to gasoline in fuel tank or storage container. Always follow the mix ratio found on stabilizer container. Run engine at least 10 minutes after adding stabilizer to allow the stabilizer to reach the carburetor. Do not empty the gas tank and carburetor if using fuel stabilizer.

NOTE: *FRESH START™* fuel cap and cartridge system automatically drips concentrated fuel preserver into your fuel tank and is an acceptable alternative to adding fuel stabilizer.

ENGINE OIL

Drain oil (with engine warm) and replace with clean engine oil. (See “ENGINE” in the Maintenance section of this manual).

CYLINDER

1. Remove spark plug.
2. Pour 29 ml of oil through spark plug hole into cylinder.
3. Pull starter handle slowly a few times to distribute oil.
4. Replace with new spark plug.

OTHER

- Do not store gasoline from one season to another.
- Replace your gasoline can if your can starts to rust. Rust and/or dirt in your gasoline will cause problems.
- If possible, store your unit indoors and cover it to protect it from dust and dirt.
- Cover your unit with a suitable protective cover that does not retain moisture. Do not use plastic. Plastic cannot breathe, which allows condensation to form and will cause your unit to rust.

IMPORTANT: Never cover mower while engine and exhaust areas are still warm.

⚠CAUTION: Never store the lawn mower with gasoline in the tank inside a building where fumes may reach an open flame or spark. Allow the engine to cool before storing in any enclosure.

TROUBLESHOOTING - See appropriate section in manual unless directed to a Sears Service Centre.

PROBLEM	CAUSE	CORRECTION
Does not start	<ol style="list-style-type: none"> 1. Dirty air filter. 2. Out of fuel. 3. Stale fuel. 4. Water in fuel. 5. Spark plug wire is disconnected. 6. Bad spark plug. 7. Loose blade or broken blade adapter. 8. Control bar in released position. 9. Control bar defective. 10. Fuel valve lever (if so equipped) in OFF position. 11. Weak battery (if equipped). 12. Disconnected battery connector (if equipped). 	<ol style="list-style-type: none"> 1. Clean/replace air filter. 2. Fill fuel tank. 3. Empty fuel tank and refill tank with fresh, clean gasoline. 4. Empty fuel tank and refill tank with fresh, clean gasoline. 5. Connect wire to plug. 6. Replace spark plug. 7. Tighten blade bolt or replace blade adapter. 8. Depress control bar to handle. 9. Replace control bar. 10. Turn fuel valve lever to the ON position. 11. Charge battery. 12. Connect battery to engine.
Loss of power	<ol style="list-style-type: none"> 1. Rear of lawn mower housing or cutting blade dragging in heavy grass. 2. Cutting too much grass. 3. Dirty air filter. 4. Buildup of grass, leaves, and trash under mower. 5. Too much oil in engine. 6. Walking speed too fast. 	<ol style="list-style-type: none"> 1. Raise cutting height. 2. Raise cutting height. 3. Clean/replace air filter. 4. Clean underside of mower housing. 5. Check oil level. 6. Cut at slower walking speed.

TROUBLESHOOTING - See appropriate section in manual unless directed to a Sears Service Centre.

PROBLEM	CAUSE	CORRECTION
Poor cut – uneven	<ol style="list-style-type: none"> 1. Worn, bent or loose blade. 2. Wheel heights uneven. 3. Buildup of grass, leaves and trash under mower. 	<ol style="list-style-type: none"> 1. Replace blade. Tighten blade bolt. 2. Set all wheels at same height. 3. Clean underside of mower housing.
Excessive vibration	<ol style="list-style-type: none"> 1. Worn, bent or loose blade. 2. Bent engine crankshaft. 	<ol style="list-style-type: none"> 1. Replace blade. Tighten blade bolt. 2. Contact a Sears or other qualified service centre.
Starter rope hard to pull	<ol style="list-style-type: none"> 1. Engine flywheel brake is on when control bar is released. 2. Bent engine crankshaft. 3. Blade adapter broken. 4. Blade dragging in grass. 	<ol style="list-style-type: none"> 1. Depress control bar to upper handle before pulling starter rope. 2. Contact a Sears or other qualified service centre. 3. Replace blade adapter. 4. Move lawn mower to cut grass or to hard surface.
Grass catcher not filling (If so equipped)	<ol style="list-style-type: none"> 1. Cutting height too low. 2. Lift on blade worn off. 3. Catcher not venting air. 	<ol style="list-style-type: none"> 1. Raise cutting height. 2. Replace blade. 3. Clean grass catcher.
Hard to push	<ol style="list-style-type: none"> 1. Grass is too high or wheel height is too low. 2. Rear of lawn mower housing or cutting blade dragging in grass. 3. Grass catcher too full. 4. Handle height position not right for you. 	<ol style="list-style-type: none"> 1. Raise cutting height. 2. Raise rear of lawn mower housing one (1) setting higher. 3. Empty grass catcher. 4. Adjust handle height to suit.
Loss of drive or slowing of drive speed	<ol style="list-style-type: none"> 1. Belt wear. 2. Belt off of pulley. 3. Drive cable worn or broken. 4. “Loose” drive control system. 	<ol style="list-style-type: none"> 1. Check/replace drive belt. 2. Check/reinstall drive belt. 3. Replace drive cable. 4. Adjust drive control.

REPAIR PARTS

CRAFTSMAN ROTARY LAWN MOWER - - MODEL NUMBER 944.365890

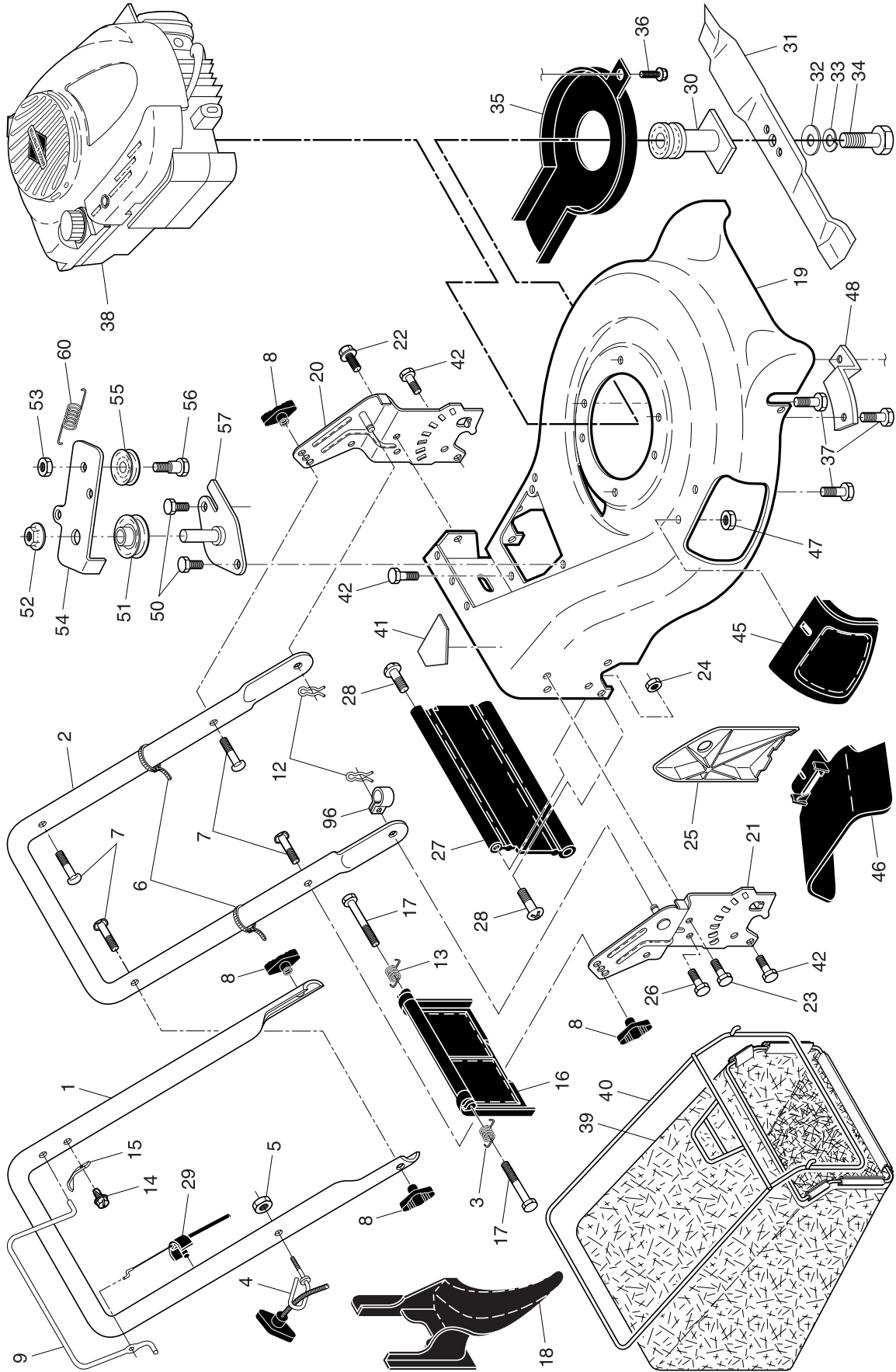

CRAFTSMAN ROTARY LAWN MOWER - - MODEL NUMBER 944.365890

KEY PART NO. NO.	DESCRIPTION	KEY PART NO. NO.	DESCRIPTION
1	194579X479	32	Washer
2	193664X479	33	Washer, Lock
3	186053	34	Bolt, Hex Head
4	179585	35	Debris Shield
5	132004	36	Bolt
6	66426	37	Bolt, Engine
7	191574	38	Engine, Briggs & Stratton, Model Number 125K02-0487-E1 (See Breakdown)
8	189713X428	39	Grassbag
9	194580X428	40	Frame, Grassbag
12	51793	41	Danger Decal
13	186052	42	Screw
14	750634	45	Mulcher Door Assembly
15	850733X004	46	Discharge Guard
16	185855X428	47	Nut, Hex
17	184193	48	Mounting Bracket, Debris Shield
18	187535	50	Screw
19	197034	51	Pulley, Idler
20	192980X479	52	Flanged Nut
21	192979X479	53	Locknut
22	150078	54	Idler Arm
23	163183	55	Idler Pulley
24	73800500	56	Shoulder Bolt
25	161333	57	Bracket Assembly
26	163409	60	Spring, Return
27	192876	96	Clip, Cable
28	88652	--	Warning Decal (not shown)
29	191221	--	Owner's Manual, English
30	189179	--	Owner's Manual, French
31	189028	--	

NOTE: All component dimensions given in U.S. inches. 1 inch = 25.4 mm.

IMPORTANT: Use only Original Equipment Manufacturer (O.E.M.) replacement parts. Failure to do so could be hazardous, damage your lawn mower and void your warranty.

CRAFTSMAN ROTARY LAWN MOWER -- MODEL NUMBER 944.365890

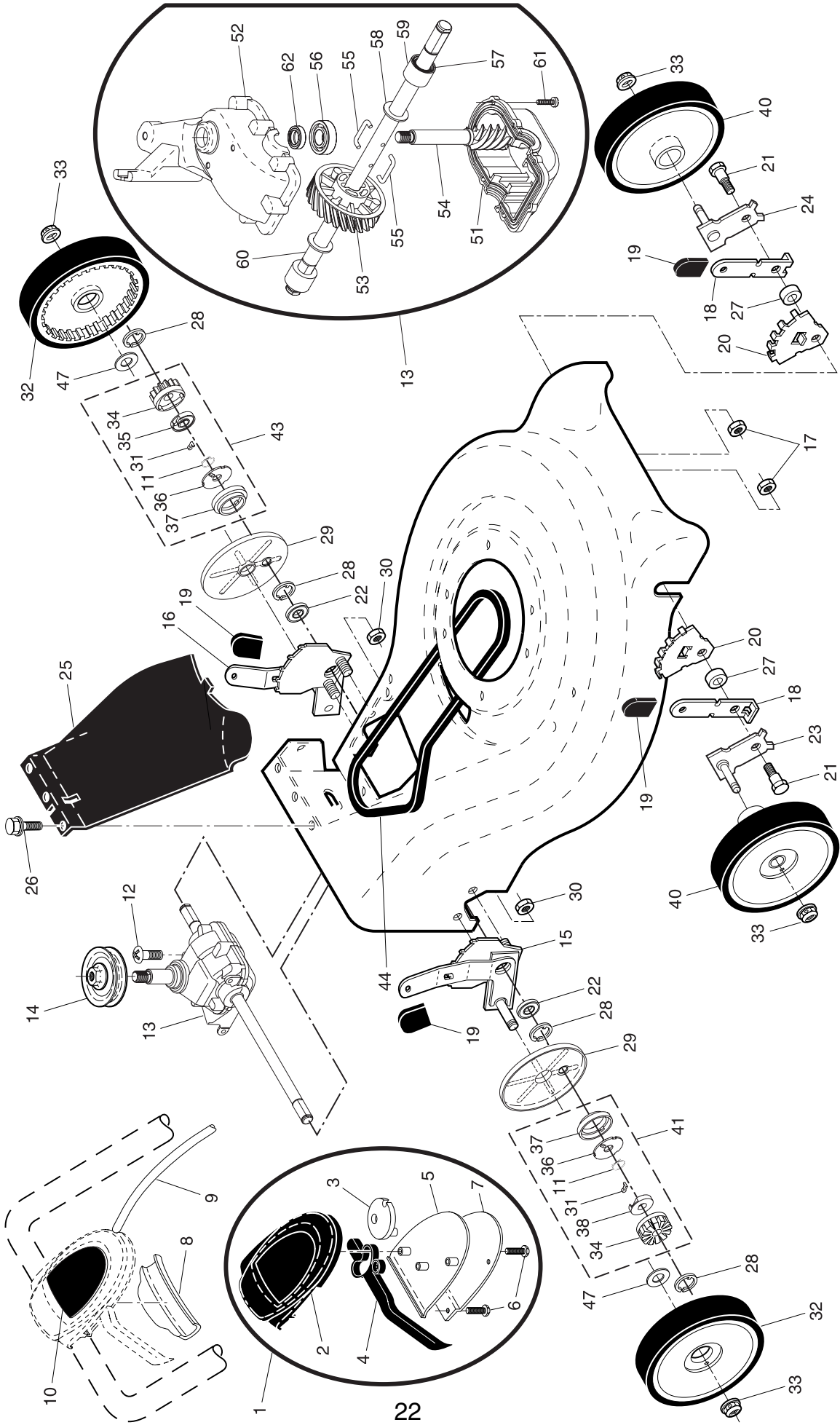

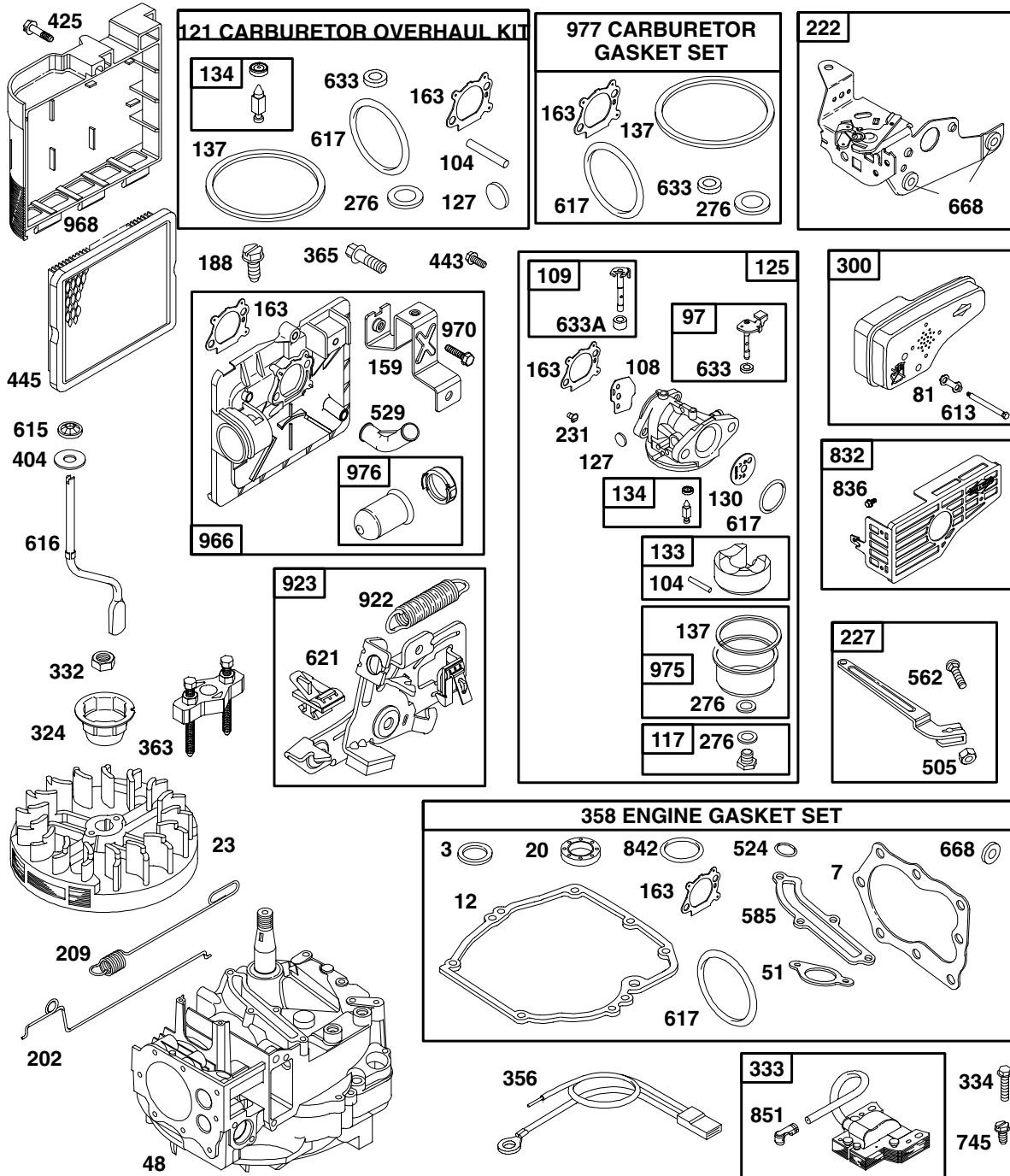

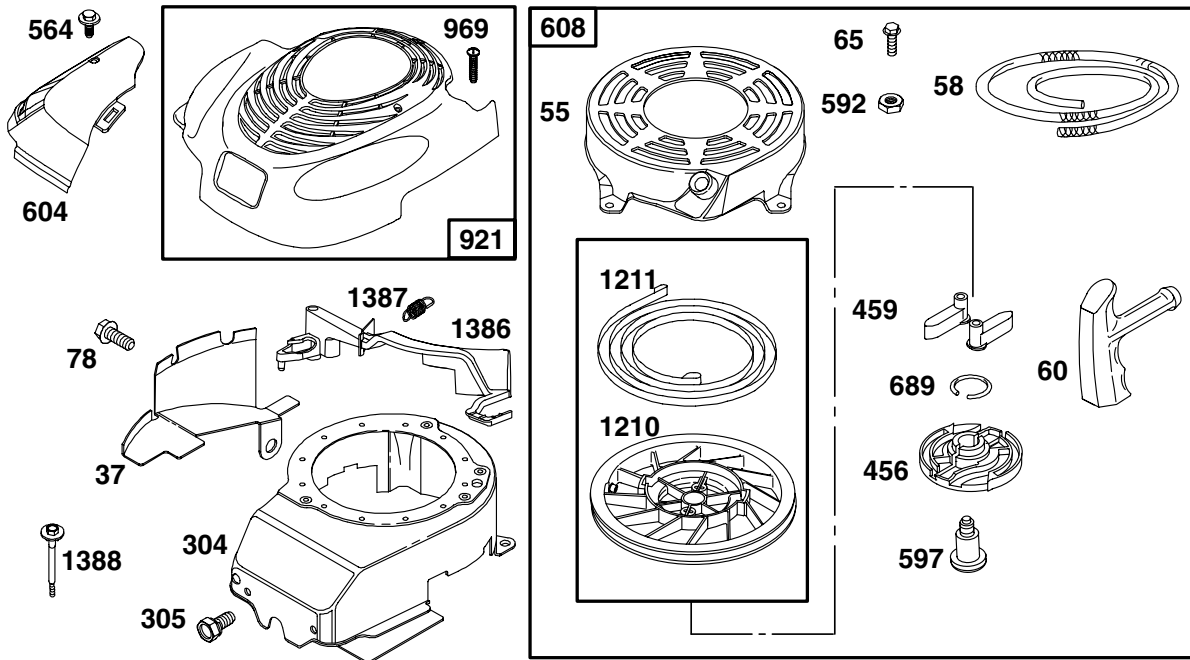

KEY PART NO.	NO.	DESCRIPTION	KEY PART NO.	NO.	DESCRIPTION
1	697322	Cylinder Assembly	46	691449	Camshaft
2	399269	Kit-Bushing/Seal	48	498829	Short Block
3	299819 •	Seal-Oil (Magneto Side)	50	497465	Manifold-Intake
4	493279	Sump-Engine	51	272199 •	Gasket-Intake
5	691160	Head-Cylinder	54	691650	Screw (Intake Manifold)
7	692249 •	Gasket-Cylinder Head	55	691421	Housing-Rewind Starter
8	695250	Breather Assembly	58	697316	Rope-Starter (Cut to Required Length)
9	699472	Gasket-Breather	60	281434	Grip-Starter Rope
10	691125	Screw (Breather Assembly)	65	690837	Screw (Rewind Starter)
11	691781	Tube-Breather	78	691108	Screw (Flywheel Guard)
12	692232 •	Gasket-Crankcase	81	691740	Lock-Muffler Screw
13	690912	Screw (Cylinder Head)	97	696565	Shaft-Throttle
15	691680	Plug-Oil Drain	104	691242 Ø	Pin-Float Hinge
16	691450	Crankshaft	108	790844	Valve-Choke
20	399781 •	Seal-Oil (PTO Side)	109	790843	Shaft-Choke
22	691092	Screw (Engine Sump)	117	697355	Jet-Main (Standard)
23	692315	Flywheel	121	498260	Kit-Carburetor Overhaul
24	222698	Key-Flywheel	125	790845	Carburetor
25	790359	Piston Assembly (Standard)	127	694468 Ø	Plug-Welch
26	790360	Ring Set-Piston (Standard)	130	696564	Valve-Throttle
27	691866	Lock-Piston Pin	133	398187	Float-Carburetor
28	499423	Pin-Piston	134	398188 Ø	Valve-Needle/Seat
29	499424	Rod-Connecting	137	693981 Ø‡	Gasket-Float Bowl
32	691664	Screw (Connecting Rod)	159	691753	Bracket-Air Cleaner Primer
32A	695759	Screw (Connecting Rod)	163	272653 •Ø‡	Gasket-Air Cleaner
33	262651	Valve-Exhaust	187	691050	Line-Fuel (Cut to Required Length)
34	262652	Valve-Intake	188	693399	Screw (Control Bracket)
35	691270	Spring-Valve (Intake)	190	690940	Screw (Fuel Tank)
36	691270	Spring-Valve (Exhaust)	202	691829	Link-Mechanical Governor
37	694086	Guard-Flywheel	209	699056	Spring-Governor
40	692194	Retainer-Valve	222	692467	Bracket-Control
43	691997	Slinger-Governor/Oil			
45	690548	Tappet-Valve			

KEY NO.	PART NO.	DESCRIPTION	KEY NO.	PART NO.	DESCRIPTION
227	690783	Control Lever-Governor	684	690345	Screw
231	691636	Screw (Choke Valve)			(Breather Passage Cover)
276	271716	Ø‡ Sealing Washer	689	691855	Spring-Friction
287	690940	Screw (Dipstick Tube)	718	690959	Pin-Locating
291	790830	Thermostat	741	691830	Gear-Timing
300	790828	Muffler	745	691648	Screw (Brake)
304	790826	Housing-Blower	832	499034	Guard-Muffler
305	691108	Screw (Blower Housing)	836	690664	Screw (Muffler Guard)
306	790836	Shield-Cylinder	842	691031	• Seal-O Ring (Dipstick Tube)
307	690345	Screw (Cylinder Shield)	847	692017	Assembly-Dipstick/Tube
324	695161	Screen/Cup Assembly	851	493880	Terminal-Spark Plug
332	690662	Nut (Flywheel)	868	697338	Seal-Valve
333	802574	Armature-Magneto	869	691155	Seat-Valve (Intake)
334	691061	Screw (Armature Magneto)	870	690380	Seat-Valve (Exhaust)
337	802592	Spark Plug	871	262001	Bushing-Guide (Exhaust)
356	692390	Wire-Stop	--	63709	Bushing-Guide (Intake)
358	497316	Engine Gasket Set	883	691881	Gasket-Exhaust
363	19069	Flywheel Puller	921	698587	Cover-Blower Housing
365	692524	Screw (Carburetor)	922	692135	Spring-Brake
383	89838	Wrench-Spark Plug	923	695891	Brake
404	690272	Washer (Governor Crank)	957	699985	Cap-Fuel Tank
425	690670	Screw (Air Cleaner Cover)	966	496116	Base-Air Cleaner Primer
443	692523	Screw (Air Cleaner Primer Base)	968	692298	Cover-Air Cleaner
445	491588	Filter-Air Cleaner Cartridge	969	690700	Screw (Blower Housing Cover)
456	692299	Plate-Pawl Friction	970	691669	Screw (Air Cleaner Primer Bracket)
459	281505	Pawl-Ratchet			
505	691251	Nut (Governor Control Lever)	972	699374	Tank-Fuel
523	495264	Dipstick	975	493640	Bowl-Float
524	692296	• Seal-Dipstick Tube	976	694395	Primer-Carburetor
525	495265	Tube-Dipstick	977	498261	Set-Carburetor Gasket
529	691923	Grommet	1019	694881	Kit-Label
562	691119	Bolt (Governor Control Lever)	1036	790411	Label-Emission
564	698589	Screw (Control Cover)	1058	275177	Owner's Manual
584	697734	Cover-Breather Passage	1059	692311	Kit-Screw/Washer
585	691879	• Gasket-Breather Passage	1210	498144	Pulley/Spring Assy. (Pulley)
592	690800	Nut (Rewind Starter)	1211	498144	Pulley/Spring Assy. (Spring)
597	691696	Screw (Pawl Friction Plate)	1329	125K02-0525	Replacement Engine
601	95162	Clamp-Hose	1330	270962	Repair Manual
604	698588	Cover-Control	1386	790848	Vane-Air
608	497680	Starter-Rewind	1387	790849	Spring-Air Vane
613	790833	Screw (Muffler)	1388	790850	Screw (Air Vane) (Auto Choke System)
615	690340	Retainer-Governor Shaft	--	398067	Spark Arrester (available accessory)
616	698801	Crank-Governor			
617	270344	•Ø‡ Seal-O Ring (Intake Manifold)			• Included in Engine Gasket Set, Key No. 358
621	692310	Switch-Stop			Ø Included in Carb. Overhaul Kit, Key No. 121
633	691321	Ø‡ Seal-Throttle Shaft			‡ Included in Carb. Gasket Set, Key No. 977
633A	693867	Ø‡ Seal-Choke Shaft			
635	66538	Boot-Spark Plug			
668	493823	• Spacer (Includes 2)			
670	692294	Spacer-Fuel Tank			

NOTE: All component dimensions given in U.S. inches. 1 inch = 25.4 mm.

Get it fixed, at your home or ours!

Just Call:

1-800-4-MY-HOME®

(1-800-469-4663)

24 hours a day, 7 days a week

For the repair of major brand appliances **in your own home...**
no matter who made it, no matter who sold it!

For your nearest **Sears Parts and Service** location,
to bring in products like vacuums, lawn equipment and electronics.

For **Sears Parts & Service**, to order the replacement parts,
accessories and owner's manuals that you need to do-it-yourself.

www.sears.ca

To purchase or inquire about a Sears Maintenance Agreement, call:

1-800-361-6665

9 a.m. – 11 p.m. Mon. – Fri., EST, 9 a.m. – 4 p.m. Sat.

Pour service en français:

1-800-LE-FOYER^{MC}

(1-800-533-6937)

www.sears.ca



® / TM Trademarks of Sears, Roebuck and Co. used under license by Sears Canada

^{MD} Marque déposée / ^{MC} Marque de commerce de Sears, Roebuck and Co. utilisée en vertu d'une licence de Sears Canada