

Get it fixed, at your home or ours!

Just Call:

1-800-4-MY-HOME®

(1-800-469-4663)

24 hours a day, 7 days a week

For the repair of major brand appliances **in your own home...**
no matter who made it, no matter who sold it!

For your nearest **Sears Parts and Service** location,
to bring in products like vacuums, lawn equipment and electronics.

For **Sears Parts & Service**, to order the replacement parts,
accessories and owner's manuals that you need to do-it-yourself.

www.sears.ca

To purchase or inquire about a Sears Maintenance Agreement, call:

1-800-361-6665

9 a.m. – 11 p.m. Mon. – Fri., EST, 9 a.m. – 4 p.m. Sat.

Pour service en français:

1-800-LE-FOYER^{MC}

(1-800-533-6937)

www.sears.ca



® / TM Trademarks of Sears, Roebuck and Co. used under license by Sears Canada

^{MD} Marque déposée / ^{MC} Marque de commerce de Sears, Roebuck and Co. utilisée en vertu d'une licence de Sears Canada

Owner's Manual



ROTARY LAWN MOWER

6.75 Horsepower

21" Multi-Cut

Model No.

944.366450

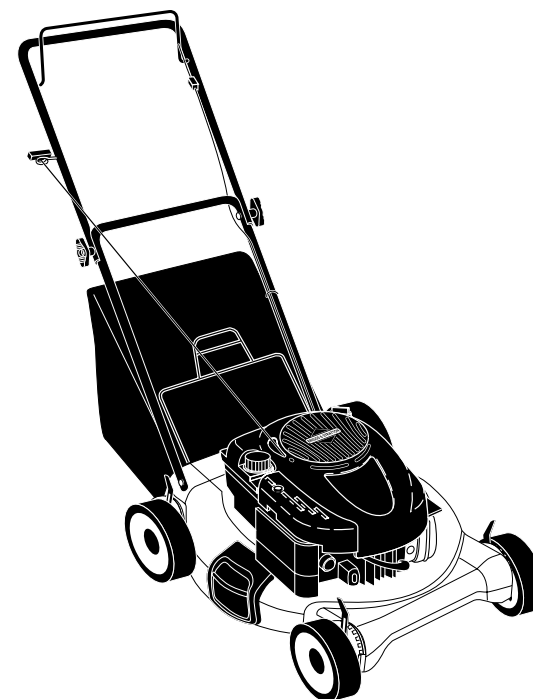

CAUTION:

Read and follow all
Safety Rules and Instructions
before operating this equipment

Sears Canada, Inc., Toronto, Ontario M5B 2B8

TABLE OF CONTENTS

Warranty	2	Maintenance	10-12
Safety Rules	2-3	Service and Adjustments	13
Product Specifications	4	Storage	14-15
Assembly/Pre-Operation	5	Troubleshooting	15-16
Operation	6-9	Repair Parts	18-23
Maintenance Schedule	10	Sears Service	Back Cover

WARRANTY

LIMITED TWO YEAR WARRANTY ON CRAFTSMAN POWER MOWER

For Two years from date of purchase Sears Canada, Inc. will repair or replace at Sears option free of charge parts which are defective as a result of material or workmanship.

COMMERCIAL OR RENTAL USE:

Warranty on Power Mower (Gas) will be ninety (90) days from date of purchase if used for commercial or rental purposes.

This Warranty does **NOT** cover:

- Pre-delivery set-up.
- In-home service
- Expendable items which become worn during normal use, such as rotary mower blades, blade adapters, belts, air cleaners and spark plug.
- Repairs necessary because of operator abuse or negligence, including bent crankshafts and the failure to maintain the equipment according to the instructions contained in the owner's manual.

Warranty service is available by returning the Craftsman Power Mower to the nearest Sears Service Centre/Department in Canada. This warranty applies only while this product is used in Canada.

This warranty is in addition to any statutory warranty and does not exclude or limit legal rights you may have but shall run concurrently with applicable provincial legislation. Furthermore, some provinces do NOT allow limitation on how long an implied warranty will last so the above limitations may not apply to you.

Sears Canada, Inc., Toronto, Ontario M5B 2B8

SAFETY RULES

IMPORTANT: This cutting machine is capable of amputating hands and feet and throwing objects. Failure to observe the following safety instructions could result in serious injury or death.

⚠ Look for this symbol to point out important safety precautions. It means **CAUTION!!! BECOME ALERT!!! YOUR SAFETY IS INVOLVED.**

⚠ WARNING: In order to prevent accidental starting when setting up, transporting, adjusting or making repairs, always disconnect spark plug wire and place wire where it cannot come in contact with plug.

⚠ CAUTION: Muffler and other engine parts become extremely hot during operation and remain hot after engine has stopped. To avoid severe burns on contact, stay away from these areas.



I. GENERAL OPERATION

- Read, understand, and follow all instructions on the machine and in the manual(s) before starting. Be thoroughly familiar with the controls and the proper use of the machine before starting.
- Do not put hands or feet near or under rotating parts. Keep clear of the discharge opening at all times.
- Only allow responsible individuals, who are familiar with the instructions, to operate the machine.
- Clear the area of objects such as rocks, toys, wire, bones, sticks, etc., which could be picked up and thrown by blade.
- Be sure the area is clear of other people before mowing. Stop machine if anyone enters the area.
- Do not operate the mower when barefoot or wearing open sandals. Always wear substantial foot wear.

2

BRIGGS & STRATTON 4-CYCLE ENGINE

MODEL NUMBER 125K02-0690-E1

KEY NO.	PART NO.	DESCRIPTION	KEY NO.	PART NO.	DESCRIPTION
97	696565	Shaft-Throttle	597	691696	Screw (Pawl Friction Plate)
104	691242	Ø Pin-Float Hinge	601	791850	Clamp-Hose
108	790844	Valve-Choke	604	698588	Cover-Control
109	790843	Shaft-Choke	608	497680	Starter-Rewind
117	697355	Jet-Main (Standard)	613	790833	Screw (Muffler)
118	494870	Jet-Main (High Altitude)	615	690340	Retainer-Governor Shaft
121	498260	Kit-Carburetor Overhaul	616	698801	Crank-Governor
125	790845	Carburetor	617	270344•Ø‡	Seal-Intake Manifold
127	694468	Ø Plug-Welch	621	692310	Switch-Stop
130	696564	Valve-Throttle	633	691321 Ø‡	Seal-Throttle Shaft
133	398187	Float-Carburetor	633A	693867 Ø‡	Seal-Choke Shaft
134	398188	Ø Valve-Needle/Seat	635	66538	Boot-Spark Plug
137	693981	Ø‡ Gasket-Float Bowl	668	493823	• Spacer (Includes 2)
163	272653•Ø‡	Gasket-Air Cleaner	670	692294	Spacer-Fuel Tank
187	791766	Line-Fuel (Cut to Length)	684	690345	Screw (Breather Cover)
188	693399	Screw (Control Bracket)	689	691855	Spring-Friction
190	690940	Screw (Fuel Tank)	718	690959	Pin-Locating
202	691829	Link-Mechanical Governor	741	790345	Gear-Timing
209	699056	Spring-Governor	745	691648	Screw (Brake)
222	791128	Bracket-Control	842	691031	• Seal-O Ring (Dipstick Tube)
227	690783	Control Lever-Governor	847	692047	Assembly-Dipstick/Tube
231	691636	Screw (Choke Valve)	851	493880	Terminal-Spark Plug
276	271716	Ø‡ Sealing Washer	868	697338	Seal-Valve
287	690940	Screw (Dipstick Tube)	869	691155	Seat-Valve (Intake)
291	790830	Thermostat	870	690380	Seat-Valve (Exhaust)
300	790828	Muffler	871	262001	Bushing-Guide (Exhaust)
304	790826	Housing-Blower		63709	Bushing-Guide (Intake)
305	691108	Screw (Blower Housing)	883	691881	Gasket-Exhaust
306	790836	Shield-Cylinder	921	698587	Cover-Blower Housing
307	690345	Screw (Cylinder Shield)	922	692135	Spring-Brake
332	690662	Nut (Flywheel)	923	695891	Brake
333	790817	Armature-Magneto	957	699985	Cap-Fuel Tank
334	691061	Screw (Armature Magneto)	966	792040	Base-Air Cleaner Primer
337	802592	Spark Plug	968	692298	Cover-Air Cleaner
356	692390	Wire-Stop	969	690700	Screw (Blower Cover)
358	497316	Engine Gasket Set	972	699374	Tank-Fuel
363	19069	Flywheel Puller	975	493640	Bowl-Float
365	692524	Screw (Carburetor)	977	498261	Set-Carburetor Gasket
383	89838	Wrench-Spark Plug	1036	792808	Label-Emissions
404	690272	Washer (Governor Crank)	1058	275177	Owner's Manual
425	690670	Screw (Air Cleaner Cover)	1059	692311	Kit-Screw/Washer
443	692523	Screw (Air Cleaner Base)	1210	498144	Pulley / Spring Assy. (Pulley)
445	491588	Filter-Air Cleaner Cartridge	1211	498144	Pulley / Spring Assy. (Spring)
455	791960	Cup-Flywheel	1329	125K02-0525	Replacement Engine
456	692299	Plate-Pawl Friction	1330	270962	Repair Manual
459	281505	Pawl-Ratchet	1386	790848	Vane-Air
505	691251	Nut (Governor Control Lever)	1387	790849	Spring-Air Vane
523	499621	Dipstick	1388	790850	Screw-Air Vane (Auto Choke)
524	692296	• Seal-Dipstick Tube	--	398067	Spark Arrestor (accessory)
525	495265	Tube-Dipstick			
529	691923	Grommet			
562	691119	Bolt (Governor Control Lever)			
564	698589	Screw (Control Cover)			
584	697734	Cover-Breather Passage			
585	691879	• Gasket-Breather Passage			
592	690800	Nut (Rewind Starter)			

23

- Included in Engine Gasket Set, Key No. 358
- Ø Included in Carb. Overhaul Kit, Key No. 121
- ‡ Included in Carb. Gasket Set, Key No. 977

NOTE: All component dimensions given in U.S. inches. 1 inch = 25.4 mm

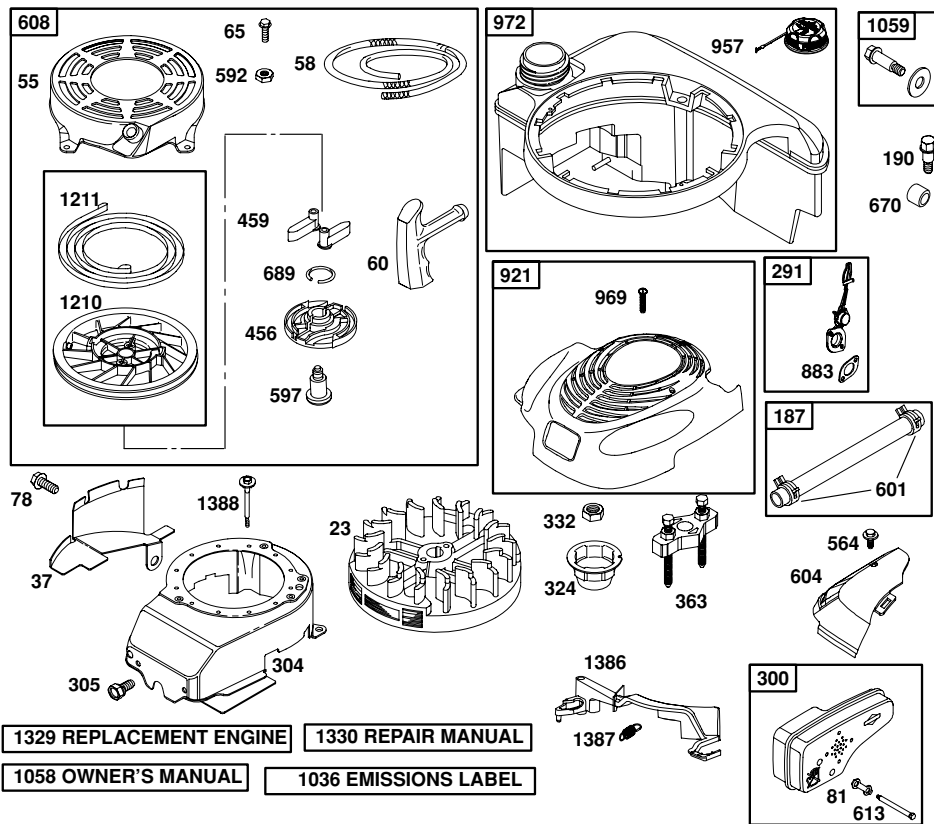

KEY PART NO.	NO.	DESCRIPTION
1	697322	Cylinder Assembly
2	399269	Kit-Bushing/Seal
3	299819	• Seal-Oil (Magneto Side)
4	493279	Sump-Engine
5	691160	Head-Cylinder
7	692249	• Gasket-Cylinder Head
8	695250	Breather Assembly
9	699472	Gasket-Breather
10	691125	Screw (Breather Assembly)
11	691781	Tube-Breather
12	692232	• Gasket-Crankcase
13	690912	Screw (Cylinder Head)
15	691680	Plug-Oil Drain
16	691450	Crankshaft
20	399781	• Seal-Oil (PTO Side)
22	691092	Screw (Engine Sump)
23	691987	Flywheel
24	222698	Key-Flywheel
25	790359	Piston Assembly (Standard)
	791326	Piston Assembly (.020" Over)
26	790360	Ring Set (Standard)
	791324	Ring Set (.020" Oversize)
27	691866	Lock-Piston Pin

KEY PART NO.	NO.	DESCRIPTION
28	499423	Pin-Piston
29	499424	Rod-Connecting
32	691664	Screw (Connecting Rod)
32A	695759	Screw (Connecting Rod)
33	262651	Valve-Exhaust
34	262652	Valve-Intake
35	691270	Spring-Valve (Intake)
36	691270	Spring-Valve (Exhaust)
37	694086	Guard-Flywheel
40	692194	Retainer-Valve
43	691997	Slinger-Governor/Oil
45	690548	Tappet-Valve
46	691449	Camshaft
48	498829	Short Block
50	497465	Manifold-Intake
51	272199	• Gasket-Intake
54	691650	Screw (Intake Manifold)
55	691421	Housing-Rewind Starter
58	697316	Rope-Starter (Cut to Length)
60	281434	Grip-Starter Rope
65	690837	Screw (Rewind Starter)
78	691108	Screw (Flywheel Guard)
81	691740	Lock-Muffler Screw

- Do not pull mower backwards unless absolutely necessary. Always look down and behind before and while moving backwards.
- Never direct discharged material toward anyone. Avoid discharging material against a wall or obstruction. Material may ricochet back toward the operator. Stop the blade when crossing gravel surfaces.
- Do not operate the mower without proper guards, plates, grass catcher or other safety protective devices in place.
- See manufacturer's instructions for proper operation and installation of accessories. Only use accessories approved by the manufacturer.
- Stop the blade(s) when crossing gravel drives, walks, or roads.
- Stop the engine (motor) whenever you leave the equipment, before cleaning the mower or unclogging the chute.
- Shut the engine (motor) off and wait until the blade comes to complete stop before removing grass catcher.
- Mow only in daylight or good artificial light.
- Do not operate the machine while under the influence of alcohol or drugs.
- Never operate machine in wet grass. Always be sure of your footing: keep a firm hold on the handle; walk, never run.
- Disengage the self-propelled mechanism or drive clutch on mowers so equipped before starting the engine.
- If the equipment should start to vibrate abnormally, stop the engine (motor) and check immediately for the cause. Vibration is generally a warning of trouble.
- Always wear safety goggles or safety glasses with side shields when operating mower.

II. SLOPE OPERATION

Slopes are a major factor related to slip & fall accidents which can result in severe injury. All slopes require extra caution. If you feel uneasy on a slope, do not mow it.

DO:

- Mow across the face of slopes: never up and down. Exercise extreme caution when changing direction on slopes.
- Remove obstacles such as rocks, tree limbs, etc.
- Watch for holes, ruts, or bumps. Tall grass can hide obstacles.

DO NOT:

- Do not trim near drop-offs, ditches or embankments. The operator could lose footing or balance.

- Do not trim excessively steep slopes.
- Do not mow on wet grass. Reduced footing could cause slipping.

III. CHILDREN

Tragic accidents can occur if the operator is not alert to the presence of children. Children are often attracted to the machine and the mowing activity. *Never* assume that children will remain where you last saw them.

- Keep children out of the trimming area and under the watchful care of another responsible adult.
- Be alert and turn machine off if children enter the area.
- Before and while walking backwards, look behind and *down* for small children.
- Never allow children to operate the machine.
- Use extra care when approaching blind corners, shrubs, trees, or other objects that may obscure vision.

IV. SAFE HANDLING OF GASOLINE

Use extreme care in handling gasoline. Gasoline is extremely flammable and the vapors are explosive.

- Extinguish all cigarettes, cigars, pipes and other sources of ignition.
- Use only an approved container.
- Never remove gas cap or add fuel with the engine running. Allow engine to cool before refueling.
- Never refuel the machine indoors.
- Never store the machine or fuel container where there is an open flame, spark or pilot light such as a water heater or on other appliances.
- Never fill containers inside a vehicle, on a truck or trailer bed with a plastic liner. Always place containers on the ground away from your vehicle before filling.
- Remove gas-powered equipment from the truck or trailer and refuel it on the ground. If this is not possible, then refuel such equipment with a portable container, rather than from a gasoline dispenser nozzle.
- Keep the nozzle in contact with the rim of the fuel tank or container opening at all times until fueling is complete. Do not use a nozzle lock-open device.
- If fuel is spilled on clothing, change clothing immediately.
- Never overfill fuel tank. Replace gas cap and tighten securely.

V. GENERAL SERVICE

- Never run machine inside a closed area.
- Never make adjustments or repairs with the engine (motor) running. Disconnect the spark plug wire, and keep the wire away from the plug to prevent accidental starting.
- Keep nuts and bolts, especially blade attachment bolts, tight and keep equipment in good condition.
- Never tamper with safety devices. Check their proper operation regularly.
- Keep machine free of grass, leaves, or other debris build-up. Clean oil or fuel spillage. Allow machine to cool before storing.
- Stop and inspect the equipment if you strike an object. Repair, if necessary, before restarting.
- Never attempt to make wheel height adjustments while the engine is running.
- Grass catcher components are subject to wear, damage, and deterioration, which could expose moving parts or allow objects to be thrown. Frequently check components and replace with manufacturer's recommended parts, when necessary.
- Mower blades are sharp and can cut. Wrap the blade(s) or wear gloves, and use extra caution when servicing them.
- Do not change the engine governor setting or overspeed the engine.
- Maintain or replace safety and instruction labels, as necessary.

⚠ WARNING: This lawn mower is equipped with an internal combustion engine and should not be used on or near any unimproved forest-covered, brush-covered or grass-covered land unless the engine's exhaust system is equipped with a spark arrester meeting applicable local or state laws (if any). If a spark arrester is used, it should be maintained in effective working order by the operator. A spark arrester for the muffler is available through your nearest Sears Service Centre (See the REPAIR PARTS section of this manual).

PRODUCT SPECIFICATIONS

Serial Number:	
Date of Purchase:	
Gasoline Capacity / Type:	1,5 Litres (Unleaded Regular)
Oil Capacity:	0,58 Litres
Oil Type (API SG-SL):	SAE 30 (above 0°C/32°F); SAE 5W-30 (below 0°C/32°F)
Spark Plug:	Champion RJ19LM (Gap: 0,76 mm)
Blade Bolt Torque:	35-40 ft. lbs. (47-54 N-m)
• The model and serial numbers will be found on a decal on the rear of the lawn mower housing. Record both serial number and date of purchase in space provided above.	

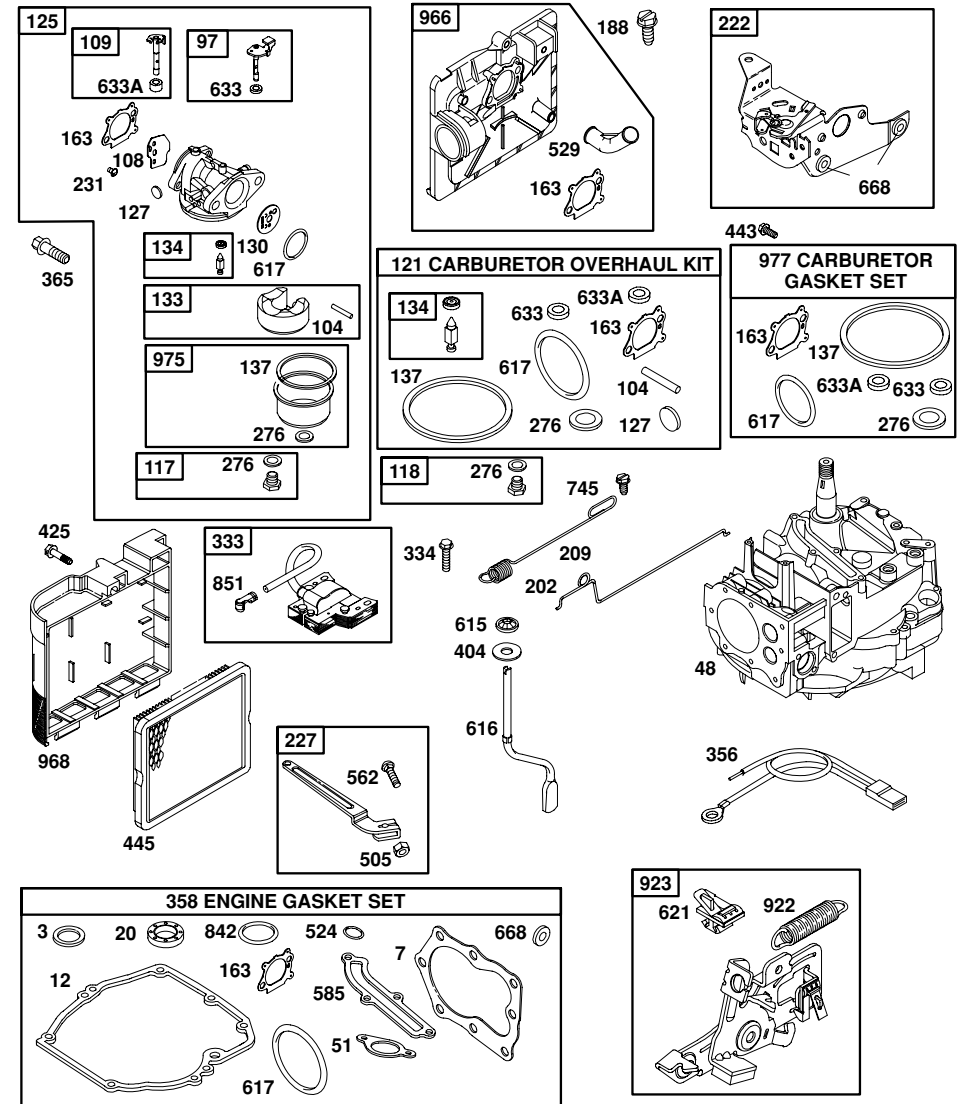

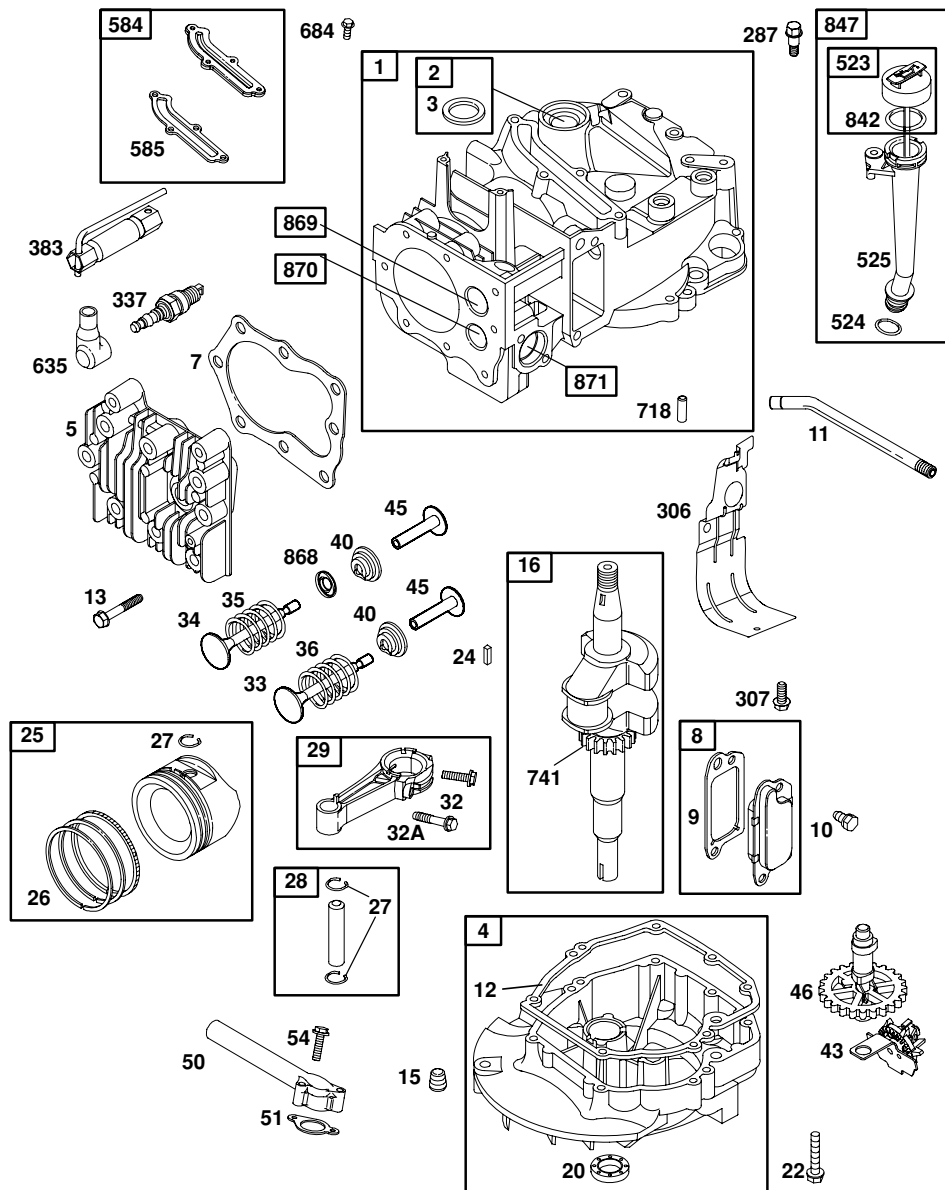

ASSEMBLY / PRE-OPERATION

Read these instructions and this manual in its entirety before you attempt to assemble or operate your new lawn mower.

IMPORTANT: This lawn mower is shipped WITHOUT OIL OR GASOLINE in the engine.

Your new lawn mower has been assembled at the factory with the exception of those parts left unassembled for shipping purposes. All parts such as nuts, washers, bolts, etc., necessary to complete the assembly have been placed in the parts bag. To ensure safe and proper operation of your lawn mower, all parts and hardware you assemble must be tightened securely. Use the correct tools as necessary to ensure proper tightness.

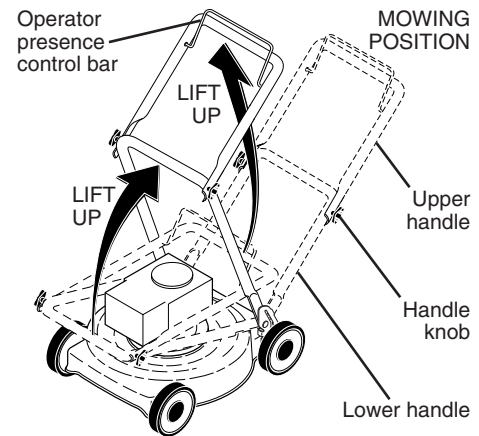

TO REMOVE MOWER FROM CARTON

1. Remove loose parts included with mower.
2. Cut down two end corners of carton and lay end panel down flat.
3. Remove all packing materials except padding between upper and lower handle and padding holding operator presence control bar to upper handle.
4. Roll lawn mower out of carton and check carton thoroughly for additional loose parts.

TO ASSEMBLE GRASS CATCHER

1. Put grass catcher frame into grass bag with rigid part of bag on the bottom. Make sure the frame handle is outside of the bag top.
 2. Slip vinyl bindings over frame.
- NOTE:** If vinyl bindings are too stiff, hold them in warm water for a few minutes. If bag gets wet, let it dry before using.

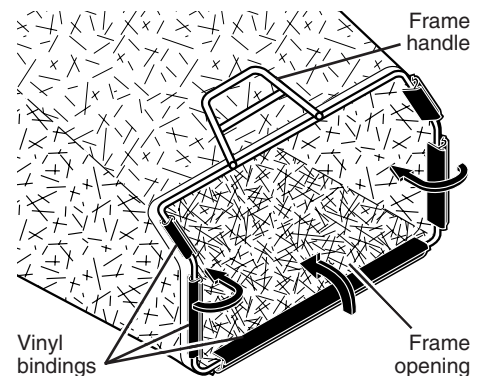

HOW TO SET UP YOUR MOWER TO UNFOLD HANDLE

- IMPORTANT:** Unfold handle carefully so as not to pinch or damage control cables.
1. Raise handles until lower handle section locks into place in mowing position.
 2. Remove protective padding, raise upper handle section into place on lower handle and tighten both handle knobs.
 3. Remove handle padding holding operator presence control bar to upper handle.

Your lawn mower handle can be adjusted for your mowing comfort. Refer to "ADJUST HANDLE" in the Service and Adjustments section of this manual.

TO INSTALL ATTACHMENTS

Your lawn mower was shipped ready to be used as a mulcher. To convert to bagging, see "TO CONVERT MOWER" in the Operation section of this manual.

OPERATION

KNOW YOUR LAWN MOWER

READ THIS OWNER'S MANUAL AND ALL SAFETY RULES BEFORE OPERATING YOUR LAWN MOWER. Compare the illustrations with your lawn mower to familiarize yourself with the location of various controls and adjustments. Save this manual for future reference.

These symbols may appear on your lawn mower or in literature supplied with the product. Learn and understand their meaning.

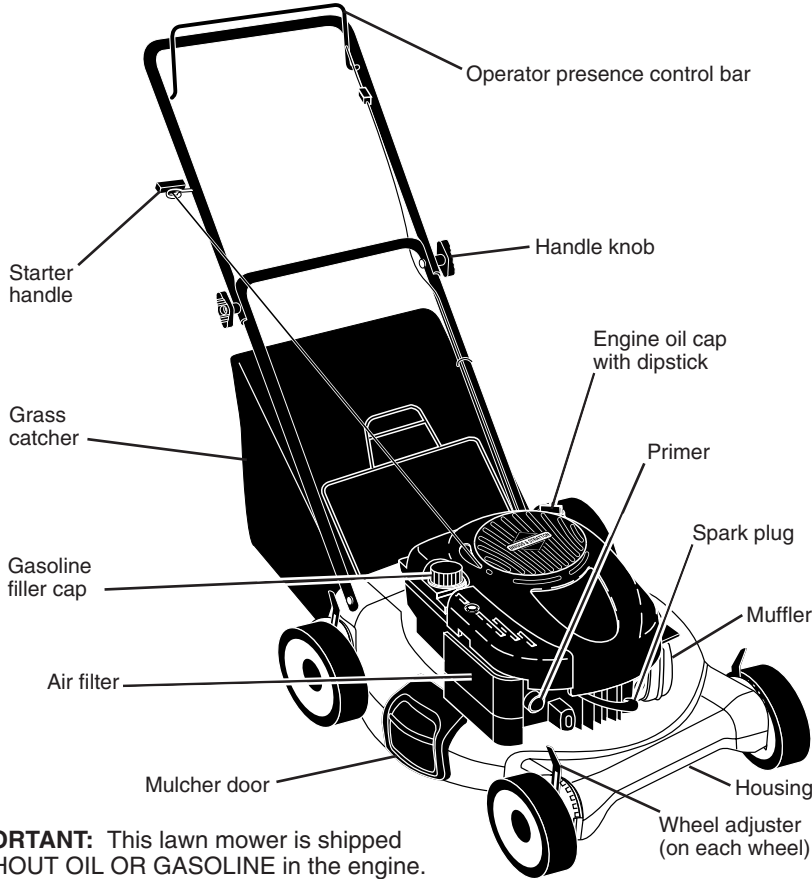
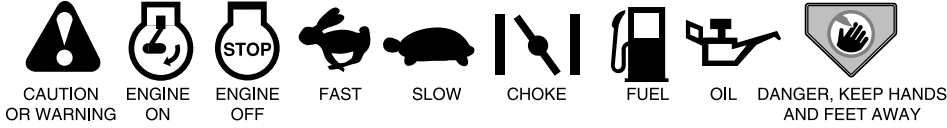

IMPORTANT: This lawn mower is shipped WITHOUT OIL OR GASOLINE in the engine.

MEETS CPSC SAFETY REQUIREMENTS

Sears rotary walk-behind power lawn mowers conform to the safety standards of the American National Standards Institute and the U.S. Consumer Product Safety Commission. The blade turns when the engine is running.

Operator presence control bar – must be held down to the handle to start the engine. Release to stop the engine.
Mulcher door – allows conversion to discharging or bagging operation.

Starter handle – used for starting engine.
Primer – pumps additional fuel from the carburetor to the cylinder for use when starting a cold engine.

CRAFTSMAN ROTARY LAWN MOWER -- MODEL NUMBER 944.366450

KEY PART NO.	DESCRIPTION	KEY PART NO.	DESCRIPTION
1	194177X428 Control Bar	33	701037 Selector Knob
2	194179X479 Upper Handle	34	186576X004 Axle Arm Assembly, Rear, LH
3	169708X479 Lower Handle	36	160828 Shoulder Bolt 5/16-18
4	194788 Rope Guide	37	194348X427 Wheel & Tire Assembly
5	132004 Nut, Hex	39	83923 Flanged Locknut
6	191574 Handle Bolt	40	194642 Frame, Grassbag
7	66426 Wire Tie	41	88652 Hinge Screw
9	154132 Hinge Bracket	42	165766 Spring, LH
10	165754 Mulcher Door	43	165767 Spring, RH
11	183281 Engine Zone Control Cable	44	184193 Bolt, Rear Door
12	750634 Hex Washer Head Screw	45	150406 Screw, Hex Head, Threaded, Rolled 3/8-16 x 1
13	86899X004 Up-Stop Bracket	46	404763 Danger Decal
14	189713X428 Handle Knob	48	186575X004 Axle Arm Assembly, Rear, RH
15	51793 Hairpin Cotter	50	403197 Grassbag
17	165946X479 Support Bracket	51	147286 Hinge Rod
18	17600406 Screw	52	190490 Kit, Lawn Mower Housing Assembly (Includes Key Numbers 17, 18 and 46)
19	186577X004 Axle Arm Assembly, Front, LH	53	851084 Screw, Hex Head, Grade 8 3/8-24 x 1-3/8
20	186578X004 Axle Arm Assembly, Front, RH	54	850263 Helical Lockwasher
21	188987 Rear Skirt	55	851074 Hardened Washer
22	168360X004 Selector Spring, Front	56	189028 21" Blade
23	186612 Kit, Rear Door (Includes Springs)	57	193707 Blade Adapter
24	73930500 Locknut, Hex 5/16-18	59	--- Engine, Briggs & Stratton, Model Number 125K02-0690-E1 (See Breakdown)
25	166111X479 Handle Bracket Assembly, LH	62	73800400 Locknut, Hex 1/4-20
26	166112X479 Handle Bracket Assembly, RH	67	197991 Clip, Cable
28	152124 Hinge Spring	--	404764 Warning Decal (not shown)
29	160835X007 Wheel Adjusting Bracket, Front	--	405340 Owner's Manual, English
30	183901 Spacer	--	405341 Owner's Manual, French
31	165760 Discharge Deflector		
32	169421X004 Selector Spring, Rear		

NOTE: All component dimensions given in U.S. inches. 1 inch = 25.4 mm.
IMPORTANT: Use only Original Equipment Manufacturer (O.E.M.) replacement parts. Failure to do so could be hazardous, damage your lawn mower and void your warranty.

REPAIR PARTS

CRAFTSMAN ROTARY LAWN MOWER -- MODEL NUMBER 944.366450

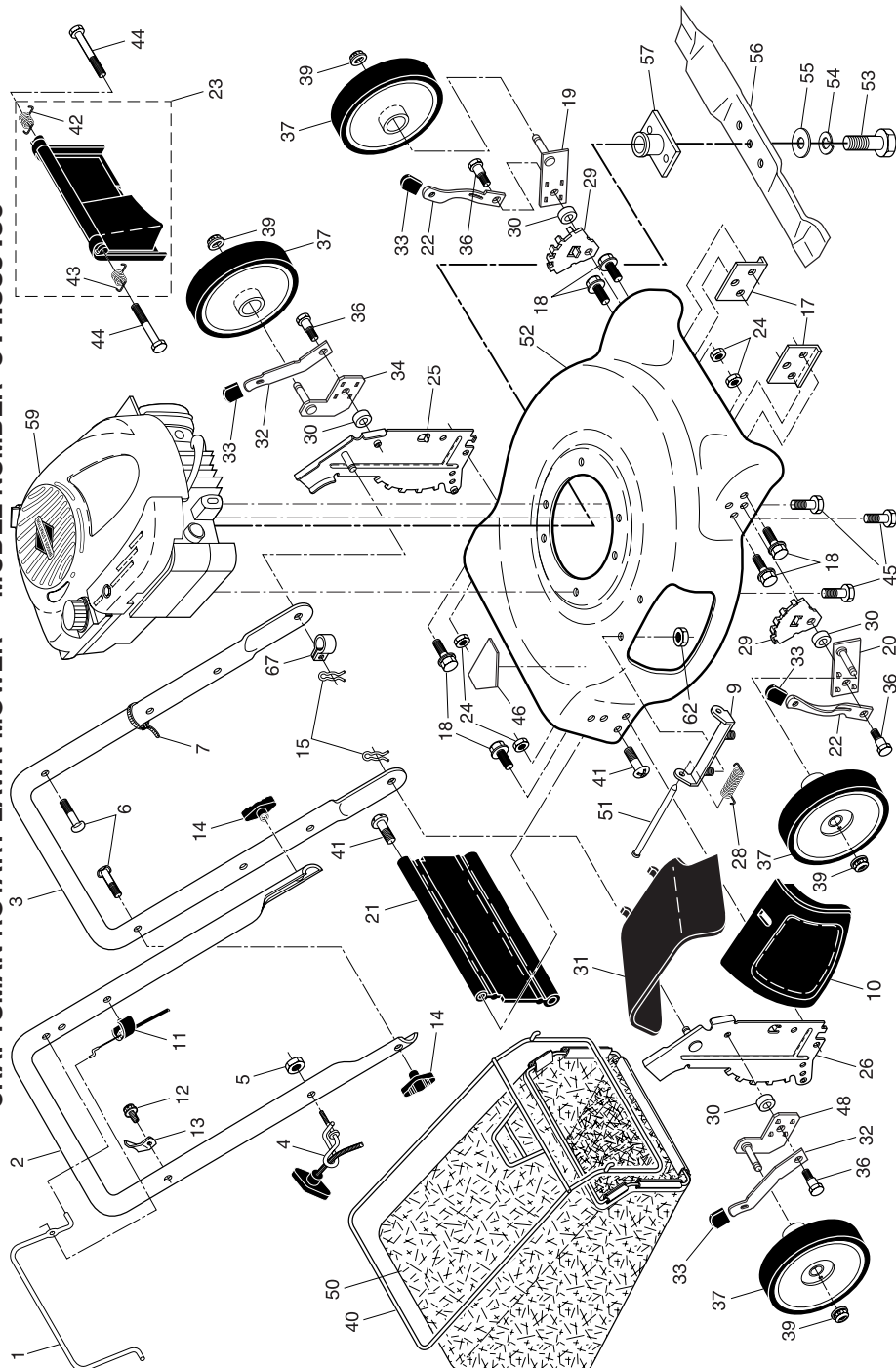

The operation of any lawn mower can result in foreign objects thrown into the eyes, which can result in severe eye damage. Always wear safety glasses or eye shields while operating your lawn mower or performing any adjustments or repairs. We recommend standard safety glasses or a wide vision safety mask worn over spectacles.

HOW TO USE YOUR LAWN MOWER ENGINE SPEED

The engine speed was set at the factory for optimum performance. Speed is not adjustable.

ENGINE ZONE CONTROL

CAUTION: Federal regulations require an engine control to be installed on this lawn mower in order to minimize the risk of blade contact injury. Do not under any circumstances attempt to defeat the function of the operator control. The blade turns when the engine is running.

- Your lawn mower is equipped with an operator presence control bar which requires the operator to be positioned behind the lawn mower handle to start and operate the lawn mower.

TO ADJUST CUTTING HEIGHT

Raise wheels for low cut and lower wheels for high cut, adjust cutting height to suit your requirements. Medium position is best for most lawns.

- To change cutting height, squeeze adjuster lever toward wheel. Move wheel up or down to suit your requirements. Be sure all wheels are in the same setting.

NOTE: Adjuster is properly positioned when plate tab inserts into hole in lever. Also, 9-position adjusters (if so equipped) allow lever to be positioned between the plate tabs.

LEVER BACKWARD TO LOWER MOWER



LEVER FORWARD TO RAISE MOWER

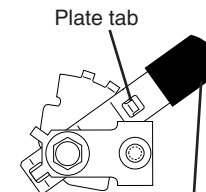

TO CONVERT MOWER

Your mower was shipped ready to be used as a mulcher. To convert to bagging/discharging:

REAR BAGGING

- Lift rear door of the lawn mower and place the grass catcher frame hooks onto the door pivot pins.

- To convert to mulching or discharging operation, remove grass catcher and close rear door.

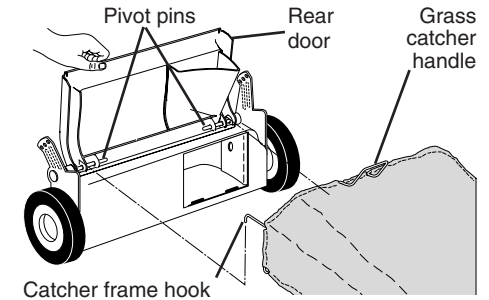

SIDE DISCHARGING

- Rear door must be closed.
- Open mulcher door and install discharge deflector under door as shown.
- Mower is now ready for discharging operation.
- To convert to mulching or bagging operation, discharge deflector must be removed and mulcher door must be closed.

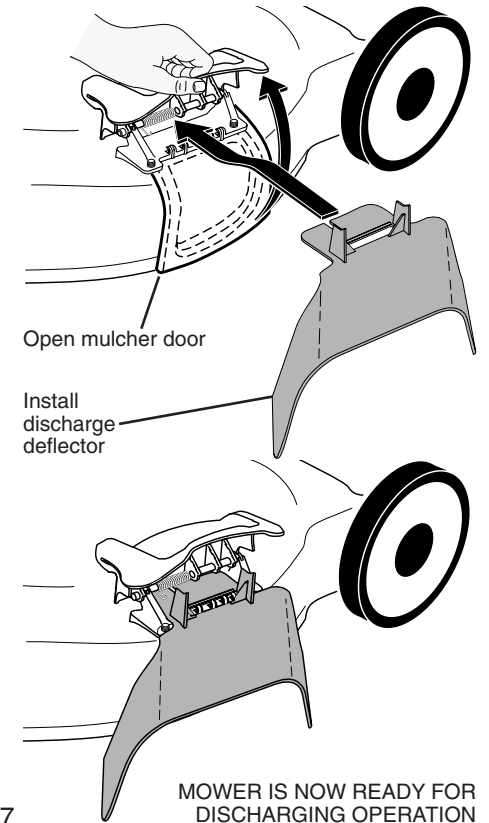

MOWER IS NOW READY FOR DISCHARGING OPERATION

SIMPLE STEPS TO REMEMBER WHEN CONVERTING YOUR LAWN MOWER FOR MULCHING -

1. Rear door closed.
2. Mulcher door closed.

FOR REAR BAGGING -

1. Grass catcher installed.
2. Mulcher door closed.

FOR SIDE DISCHARGING -

1. Rear door closed.
2. Discharge deflector installed.

CAUTION: Do not run your lawn mower without rear door closed, clipping deflector or approved grass catcher in place. Never attempt to operate the lawn mower with the rear door removed or propped open.

TO EMPTY GRASS CATCHER

1. Lift up on catcher using frame handle.
2. Remove grass catcher with clippings from under lawn mower handle.
3. Empty clippings from bag.

NOTE: Do not drag the bag when emptying; it will cause unnecessary wear.

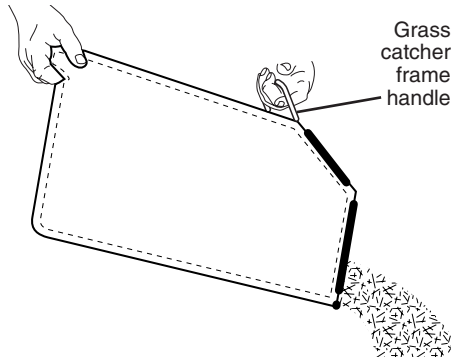

BEFORE STARTING ENGINE

ADD OIL

Your lawnmower is shipped without oil in the engine. For type and grade of oil to use, see "ENGINE" in the Maintenance section of this manual.

CAUTION: DO NOT overfill engine with oil, or it will smoke heavily from the muffler on startup.

1. Be sure lawnmower is level.
2. Remove oil dipstick from oil fill spout.
3. You receive a container of oil with the unit. Slowly pour the entire container down the oil fill spout into the engine.

NOTE: Initial oil fill requires only 18 oz. due to residual oil in engine from the manufacturer's 100% quality testing. When changing oil you may need 20 oz.

4. Insert and tighten dipstick.

IMPORTANT:

- Check oil level before each use. Add oil if needed. Fill to full line on dipstick.
- Change the oil after every 25 hours of operation or each season. You may need to change the oil more often under dusty, dirty conditions. See "TO CHANGE ENGINE OIL" in the Maintenance section of this manual.

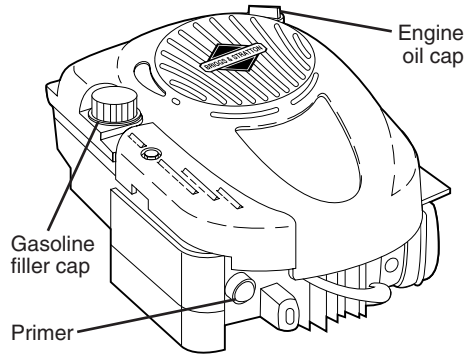

ATTACH FUEL CAP CARTRIDGE

Your mower is equipped with a special *FRESH START™* fuel cap and continuous fuel preserver cartridge. See the information and instructions packed with the *FRESH START™* cartridge.

1. Snap cartridge into bottom of fuel cap.
- NOTE:** Do not remove the silver foil seal on the side of cartridge that snaps into fuel cap.
2. Grasp the white peel tab and pull to remove the entire seal.
 3. Screw fuel cap onto fuel tank after filling tank with gasoline.

Replace cartridge when empty (about once a season). Check preserver level visually.

DANGER: Cartridge fluid is HARMFUL OR FATAL IF SWALLOWED. Avoid contact to eyes, skin, or clothing. Do not take internally. Do not inhale fluid vapor. Keep out of reach of children. If swallowed, call a physician immediately.

ADD GASOLINE

- Fill fuel tank to bottom of tank filler neck. Do not overfill. Use fresh, clean, regular unleaded gasoline with a minimum of 87 octane. Do not mix oil with gasoline. Purchase fuel in quantities that can be used within 30 days to assure fuel freshness.

CAUTION: Wipe off any spilled oil or fuel. Do not store, spill or use gasoline near an open flame.

SERVICE NOTES

TROUBLESHOOTING - See appropriate section in manual unless directed to a Sears Service Centre.

PROBLEM	CAUSE	CORRECTION
Loss of power	<ol style="list-style-type: none"> Rear of mower housing or blade dragging in grass. Cutting too much grass. Dirty air filter. Buildup of grass, leaves, and trash under mower. Too much oil in engine. Walking speed too fast. 	<ol style="list-style-type: none"> Raise cutting height. Raise cutting height. Clean/replace air filter. Clean underside of mower housing. Check oil level. Cut at slower walking speed.
Poor cut – uneven	<ol style="list-style-type: none"> Worn, bent or loose blade. Wheel heights uneven. Buildup of grass, leaves and trash under mower. 	<ol style="list-style-type: none"> Replace blade. Tighten blade bolt. Set all wheels at same height. Clean underside of mower housing.
Excessive vibration	<ol style="list-style-type: none"> Worn, bent or loose blade. Bent engine crankshaft. 	<ol style="list-style-type: none"> Replace blade. Tighten blade bolt. Contact a Sears or other qualified service centre.
Starter rope hard to pull	<ol style="list-style-type: none"> Engine flywheel brake is on when control bar is released. Bent engine crankshaft. Blade adapter broken. Blade dragging in grass. 	<ol style="list-style-type: none"> Depress control bar to upper handle before pulling the starter rope. Contact a Sears or other qualified service centre. Replace blade adapter. Move lawn mower to cut grass or to hard surface.
Grass catcher not filling (If so equipped)	<ol style="list-style-type: none"> Cutting height too low. Lift on blade worn off. Catcher not venting air. 	<ol style="list-style-type: none"> Raise cutting height. Replace blade. Clean grass catcher.
Hard to push	<ol style="list-style-type: none"> Grass is too high or wheel height is too low. Rear of mower housing or blade dragging in grass. Grass catcher too full. Handle height position not right for you. 	<ol style="list-style-type: none"> Raise cutting height. Raise rear of mower housing one (1) setting higher. Empty grass catcher. Adjust handle height to suit.

⚠ CAUTION: Alcohol blended fuels (called gasohol or using ethanol or methanol) can attract moisture which leads to separation and formation of acids during storage. Acidic gas can damage the fuel system of an engine while in storage. To avoid engine problems, the fuel system should be emptied before storage of 30 days or longer. Empty the gas tank, start the engine and let it run until the fuel lines and carburetor are empty. Use fresh fuel next season. See Storage Instructions for additional information. Never use engine or carburetor cleaner products in the fuel tank or permanent damage may occur.

TO STOP ENGINE

- To stop engine, release operator presence control bar.

TO START ENGINE

NOTE: Due to protective coatings on the engine, a small amount of smoke may be present during the initial use of the product and should be considered normal.

- To start a cold engine, push primer three (3) times before trying to start. Use a firm push. This step is not usually necessary when starting an engine which has already run for a few minutes.
- Hold operator presence control bar down to the handle and pull starter handle quickly. Do not allow starter rope to snap back.

NOTE: In cooler weather it may be necessary to repeat priming steps. In warmer weather over priming may cause flooding and engine will not start. If you do flood engine, wait a few minutes before attempting to start and do not repeat priming steps.

MOWING TIPS

⚠ CAUTION: Do not use de-thatcher blade attachments on your mower. Such attachments are hazardous, will damage your mower and could void your warranty.

- Under certain conditions, such as very tall grass, it may be necessary to raise the height of cut to reduce pushing effort and to keep from overloading the engine and leaving clumps of grass clippings. It may also be necessary to reduce ground speed and/or run the lawn mower over the area a second time.
- For extremely heavy cutting, reduce the width of cut by overlapping previously cut path and mow slowly.
- For better grass bagging and most cutting conditions, the engine speed should be set in the FAST position.

- Pores in cloth grass catchers can become filled with dirt and dust with use and catchers will collect less grass. To prevent this, regularly hose catcher off with water and let dry before using.
- Keep top of engine around starter clear and clean of grass clippings and chaff. This will help engine air flow and extend engine life.

MULCHING MOWING TIPS

IMPORTANT: For best performance, keep mower housing free of built-up grass and trash. See “CLEANING” in the Maintenance section of this manual.

- The special mulching blade will recut the grass clippings many times and reduce them in size so that as they fall onto the lawn they will disperse into the grass and not be noticed. Also, the mulched grass will biodegrade quickly to provide nutrients for the lawn. Always mulch with your highest engine (blade) speed as this will provide the best recutting action of the blades.
- Avoid cutting your lawn when it is wet. Wet grass tends to form clumps and interferes with the mulching action. The best time to mow your lawn is the early afternoon. At this time the grass has dried, yet the newly cut area will not be exposed to direct sunlight.
- For best results, adjust the lawn mower cutting height so that the lawn mower cuts off only the top one-third of the grass blades. If the lawn is overgrown it will be necessary to raise the height of cut to reduce pushing effort and to keep from overloading the engine and leaving clumps of mulched grass. For extremely heavy grass, reduce your width of cut by overlapping previously cut path and mow slowly.

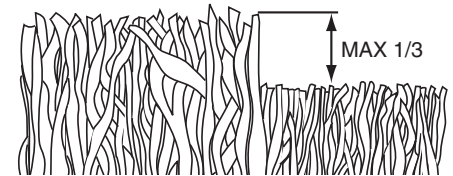

- Certain types of grass and grass conditions may require that an area be mulched a second time to completely hide the clippings. When doing a second cut, mow across (perpendicular) to the first cut path.
- Change your cutting pattern from week to week. Mow north to south one week then change to east to west the next week. This will help prevent matting and graining of the lawn.

MAINTENANCE

MAINTENANCE SCHEDULE		BEFORE EACH USE	AFTER EACH USE	EVERY 10 HOURS	EVERY 25 HOURS OR SEASON	EVERY 100 HOURS	BEFORE STORAGE
LAWN MOWER	Check for Loose Fasteners	✓					✓
	Clean / Inspect Grass Catcher *	✓	✓				✓
	Check Tires	✓					
	Check Drive Wheels ***	✓					
	Clean Lawn Mower ****		✓				✓
ENGINE	Clean under Drive Cover ***			✓			
	Check Drive Belt / Pulleys ***				✓		
	Check / Sharpen / Replace Blade				✓ ₃		
	Lubrication				✓		
	Clean and Recharge Battery **				✓		✓ ₄
ENGINE	Check Engine Oil level	✓ ₅					
	Change Engine Oil				✓ _{1,2}		
	Clean Air Filter				✓ ₂		
	Inspect Muffler				✓		
	Replace Spark Plug					✓	
	Replace Air Filter Paper Cartridge					✓ ₂	
	Empty fuel system or add Stabilizer						✓

* (if so equipped)

** Electric-Start mowers

*** Power-Propelled mowers

**** Use a scraper

to clean under deck

1 - Change more often if operating under a heavy load or in high outdoor temperatures.

2 - Service more often if operating in dirty or dusty conditions.

3 - Replace blades more often when mowing in sandy soil.

4 - Charge 48 hours at end of season.

5 - And after each 5 hours of use.

GENERAL RECOMMENDATIONS

The warranty on this lawn mower does not cover items that have been subjected to operator abuse or negligence. To receive full value from the warranty, operator must maintain unit as instructed in this manual.

Some adjustments will need to be made periodically to properly maintain your unit.

At least once a season, check to see if you should make any of the adjustments described in the Service and Adjustments section of this manual.

- At least once a year, replace the spark plug, clean or replace air filter element and check blade for wear. A new spark plug and clean/new air filter element assure proper air-fuel mixture and help your engine run better and last longer.
- Follow the maintenance schedule in this manual.

BEFORE EACH USE

- Check engine oil level.
- Check for loose fasteners.

LUBRICATION

Keep unit well lubricated (See "LUBRICATION CHART").

LUBRICATION CHART

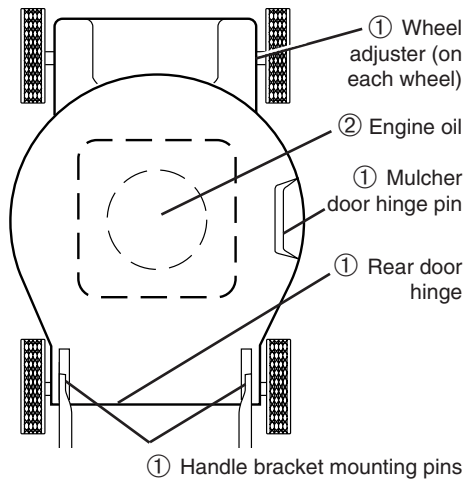

① Spray lubricant

② See "ENGINE" in Maintenance section.

IMPORTANT: Do not oil or grease plastic wheel bearings. Viscous lubricants will attract dust and dirt that will shorten the life of the self-lubricating bearings. If you feel they must be lubricated, use only a dry, powdered graphite type lubricant sparingly.

ENGINE OIL

Drain oil (with engine warm) and replace with clean engine oil. (See "ENGINE" in the Maintenance section of this manual).

CYLINDER

1. Remove spark plug.
2. Pour 29 ml of oil through spark plug hole into cylinder.
3. Pull starter handle slowly a few times to distribute oil.
4. Replace with new spark plug.

OTHER

- Do not store gasoline from one season to another.

- Replace your gasoline can if your can starts to rust. Rust and/or dirt in your gasoline will cause problems.
- If possible, store your unit indoors and cover it to protect it from dust and dirt.
- Cover your unit with a suitable protective cover that does not retain moisture. Do not use plastic. Plastic cannot breathe, which allows condensation to form and will cause your unit to rust.

IMPORTANT: Never cover mower while engine and exhaust areas are still warm.

CAUTION: Never store the lawn mower with gasoline in the tank inside a building where fumes may reach an open flame or spark. Allow the engine to cool before storing in any enclosure.

TROUBLESHOOTING - See appropriate section in manual unless directed to a Sears Service Centre.

PROBLEM	CAUSE	CORRECTION
Does not start	1. Dirty air filter.	1. Clean/replace air filter.
	2. Out of fuel.	2. Fill fuel tank.
	3. Stale fuel.	3. Empty fuel tank and refill tank with fresh, clean gasoline.
	4. Water in fuel.	4. Empty fuel tank and refill tank with fresh, clean gasoline.
	5. Spark plug wire is disconnected.	5. Connect wire to plug.
	6. Bad spark plug.	6. Replace spark plug.
	7. Loose blade or broken blade adapter.	7. Tighten blade bolt or replace blade adapter.
	8. Control bar in released position.	8. Depress control bar to handle.
	9. Control bar defective.	9. Replace control bar.
	10. Fuel valve lever (if so equipped) in OFF position.	10. Turn fuel valve lever to the ON position.
	11. Weak battery (if equipped).	11. Charge battery.
	12. Disconnected battery connector (if equipped).	12. Connect battery to engine.

STORAGE

Immediately prepare your lawn mower for storage at the end of the season or if the unit will not be used for 30 days or more.

LAWN MOWER

When lawn mower is to be stored for a period of time, clean it thoroughly, remove all dirt, grease, leaves, etc. Store in a clean, dry area.

1. Clean entire lawn mower (See "CLEANING" in the Maintenance section of this manual).
2. Lubricate as shown in the Maintenance section of this manual.
3. Be sure that all nuts, bolts, screws, and pins are securely fastened. Inspect moving parts for damage, breakage and wear. Replace if necessary.
4. Touch up all rusted or chipped paint surfaces; sand lightly before painting.

HANDLE

You can fold your lawn mower handle for storage.

1. Squeeze the bottom ends of the lower handle toward each other until the lower handle clears the handle bracket, then move handle forward.
2. Loosen upper handle mounting bolts enough to allow upper handle to be folded back.

IMPORTANT: When folding the handle for storage or transportation, be sure to fold the handle as shown or you may damage the control cables.

- When setting up your handle from the storage position, the lower handle will automatically lock into the mowing position.

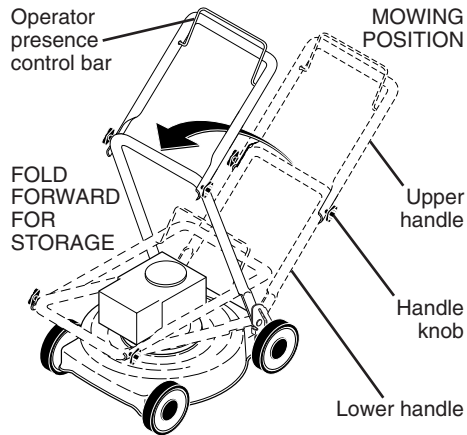
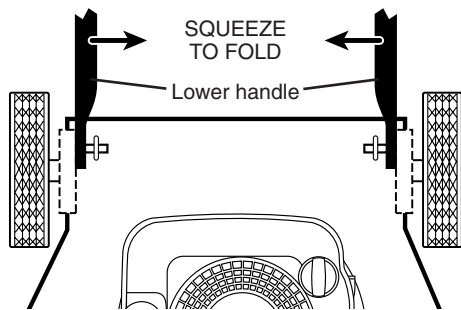

ENGINE

FUEL SYSTEM

IMPORTANT: It is important to prevent gum deposits from forming in essential fuel system parts such as carburetor, fuel filter, fuel hose or tank during storage.

Alcohol blended fuels (called gasohol or using ethanol or methanol) can attract moisture which leads to separation and formation of acids during storage. Acidic gas can damage the fuel system of an engine while in storage.

- Empty the fuel tank by starting the engine and letting it run until the fuel lines and carburetor are empty.
- Never use engine or carburetor cleaner products in the fuel tank or permanent damage may occur.
- Use fresh fuel next season.

NOTE: Fuel stabilizer is an acceptable alternative in minimizing the formation of fuel gum deposits during storage. Add stabilizer to gasoline in fuel tank or storage container. Always follow the mix ratio found on stabilizer container. Run engine at least 10 minutes after adding stabilizer to allow the stabilizer to reach the carburetor. Do not empty the gas tank and carburetor if using fuel stabilizer.

NOTE: FRESH START™ fuel cap and cartridge system automatically drips concentrated fuel preserver into your fuel tank and is an acceptable alternative to adding fuel stabilizer.

LAWN MOWER

Always observe safety rules when performing any maintenance.

TIRES

- Keep tires free of gasoline, oil, or insect control chemicals which can harm rubber.
- Avoid stumps, stones, deep ruts, sharp objects and other hazards that may cause tire damage.

BLADE CARE

For best results, blade must be kept sharp. Replace a bent or damaged blade.

CAUTION: Use only a replacement blade approved by the manufacturer of your mower. Using a blade not approved by the manufacturer of your mower is hazardous, could damage your mower and void your warranty.

TO REMOVE BLADE

1. Disconnect spark plug wire from spark plug and place wire where it cannot come in contact with plug.
2. Turn lawn mower on its side. Make sure air filter and carburetor are up.
3. Use a wood block between blade and mower housing to prevent blade from turning when removing blade bolt.

NOTE: Protect your hands with gloves and/or wrap blade with heavy cloth.

4. Remove blade bolt by turning counter-clockwise.
5. Remove blade and attaching hardware (bolt, lock washer, hardened washer).

NOTE: Remove the blade adapter and check the key inside hub of blade adapter. The key must be in good condition to work properly. Replace adapter if damaged.

TO REPLACE BLADE

1. Position the blade adapter on the engine crankshaft. Be sure key in adapter and crankshaft keyway are aligned.
2. Position blade on the blade adapter aligning the two (2) holes in the blade with the raised lugs on the adapter.
3. Be sure the trailing edge of blade (opposite sharp edge) is up toward engine.
4. Install the blade bolt with the lock washer and hardened washer into blade adapter and crankshaft.
5. Use block of wood between blade and lawn mower housing and tighten the blade bolt, turning clockwise.

- The recommended tightening torque is 35-40 ft. lbs. / 47-54 N-m.

IMPORTANT: Blade bolt is heat treated. If bolt needs replacing, replace only with approved bolt shown in the Repair Parts section of this manual.

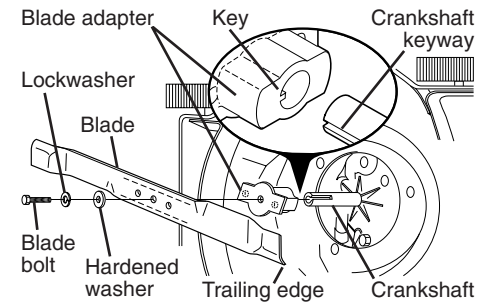

TO SHARPEN BLADE

NOTE: We do not recommend sharpening blade - but if you do, be sure the blade is balanced. Care should be taken to keep the blade balanced. An unbalanced blade will cause eventual damage to lawn mower or engine.

- The blade can be sharpened with a file or on a grinding wheel. Do not attempt to sharpen while on the mower.
- To check blade balance, drive a nail into a beam or wall. Leave about one inch of the straight nail exposed. Place center hole of blade over the head of the nail. If blade is balanced, it should remain in a horizontal position. If either end of the blade moves downward, sharpen the heavy end until the blade is balanced.

GRASS CATCHER

- The grass catcher may be hosed with water, but must be dry when used.
- Check your grass catcher often for damage or deterioration. Through normal use it will wear. If catcher needs replacing, replace only with approved replacement catcher shown in the Repair Parts section of this manual. Give the lawn mower model number when ordering.

ENGINE

LUBRICATION

Use only high quality detergent oil rated with API service classification SG-SL. Select the oil's SAE viscosity grade according to your expected operating temperature.

SAE VISCOSITY GRADES	
5W-30	SAE 30
F	100
-20	32
0	40
C	10
-30	20
-20	30
-10	40
TEMPERATURE RANGE ANTICIPATED BEFORE NEXT OIL CHANGE	

NOTE: Although multi-viscosity oils (5W30, 10W30 etc.) improve starting in cold weather, these multi-viscosity oils will result in increased oil consumption when used above 32°F. Check your engine oil level more frequently to avoid possible engine damage from running low on oil.

Change the oil after every 25 hours of operation or at least once a year if the lawn mower is not used for 25 hours in one year. Check the crankcase oil level before starting the engine and after each five (5) hours of continuous use. Tighten oil plug securely each time you check the oil level.

TO CHANGE ENGINE OIL

NOTE: Before tipping lawn mower to drain oil, drain fuel tank by running engine until fuel tank is empty.

1. Disconnect spark plug wire from spark plug and place wire where it cannot come in contact with spark plug.
2. Remove engine oil cap; lay aside on a clean surface.
3. Tip lawn mower on its side as shown and drain oil into a suitable container. Rock lawn mower back and forth to remove any oil trapped inside of engine.
4. Wipe off any spilled oil from lawn mower or side of engine.

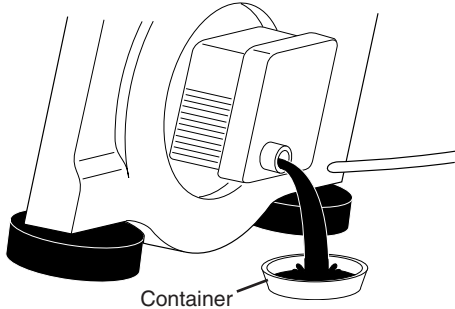

5. Slowly pour oil down the oil fill spout, stopping every few ounces to check the oil level with the dipstick.
6. Stop adding oil when you reach the FULL mark on the dipstick. Wait a minute to allow oil to settle.
7. Continue adding small amounts of oil, rechecking the dipstick until oil level settles at FULL. DO NOT overfill, or engine will smoke heavily from the muffler on startup.
8. Always be sure to retighten oil dipstick before starting engine.
9. Reconnect spark plug wire to plug.

AIR FILTER

Your engine will not run properly and may be damaged by using a dirty air filter. Replace the air filter cartridge every 100 hours of operation or every season, whichever occurs first. Service air cleaner more often under dusty conditions.

TO CLEAN AIR FILTER

1. Loosen screw and tilt cover to remove.
2. Carefully remove cartridge.

3. Clean by gently tapping on a flat surface. If very dirty, replace cartridge. **CAUTION:** Petroleum solvents, such as kerosene, are not to be used to clean cartridge. They may cause deterioration of the cartridge. Do not oil cartridge. Do not use pressurized air to clean or dry cartridge.
4. Install cartridge, then replace cover making sure the tabs are aligned with the slots in the back plate. Fasten screw securely.

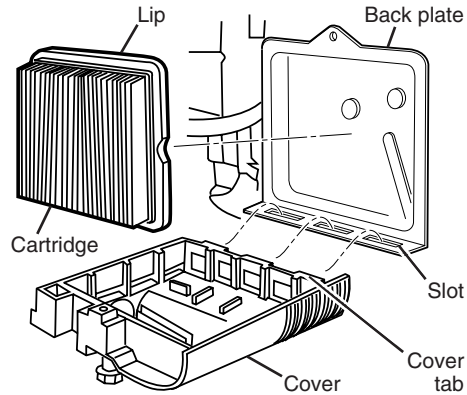

MUFFLER

Inspect and replace corroded muffler as it could create a fire hazard and/or damage.

SPARK PLUG

Replace spark plug at the beginning of each mowing season or after every 100 hours of operation, whichever occurs first. Spark plug type and gap setting are shown in the "PRODUCT SPECIFICATIONS" section of this manual.

CLEANING

IMPORTANT: For best performance, keep mower housing free of built-up grass and trash. Clean the underside of your mower after each use.

- CAUTION:** Disconnect spark plug wire from spark plug and place wire where it cannot come in contact with plug.
- Clean the underside of your lawn mower by scraping to remove build-up of grass and trash.
 - Clean engine often to keep trash from accumulating. A clogged engine runs hotter and shortens engine life.
 - Keep finished surfaces and wheels free of all gasoline, oil, etc.
 - We do not recommend using a garden hose to clean lawn mower unless the electrical system, muffler, air filter and carburetor are covered to keep water out. Water in engine can result in shortened engine life.

SERVICE AND ADJUSTMENTS

WARNING: To avoid serious injury, before performing any service or adjustments:

1. Release control bar and stop engine.
2. Make sure the blade and all moving parts have completely stopped.
3. Disconnect spark plug wire from spark plug and place wire where it cannot come in contact with plug.

LAWN MOWER

TO ADJUST CUTTING HEIGHT

See "TO ADJUST CUTTING HEIGHT" in the Operation section of this manual.

REAR DEFLECTOR

The rear deflector, attached between the rear wheels of your mower, is provided to minimize the possibility that objects will be thrown out of the rear of the mower into the operator mowing position. If the deflector becomes damaged, it should be replaced.

TO ADJUST HANDLE

The handle can be mounted in a high or low position. The mounting holes in the bottom of lower handle are off center for raising or lowering the handle.

1. Remove upper handle and all wire tie(s) securing cable(s) to lower handle.
2. Remove hairpin cotter from lower handle bracket mounting pin.
3. Squeeze lower handle in to remove it from mounting pins.
4. Turn lower handle over to raise or lower handle.
5. Squeeze lower handle in and position holes onto mounting pins on handle bracket.
6. Reassemble upper handle and all parts removed from lower handle.

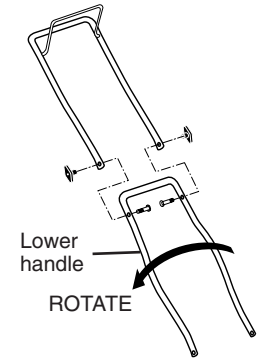
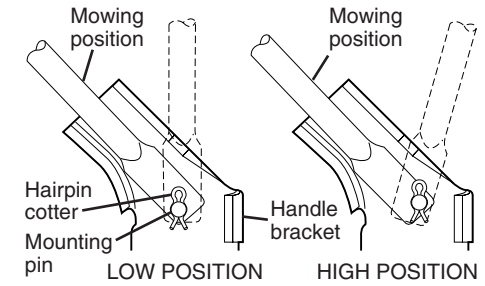
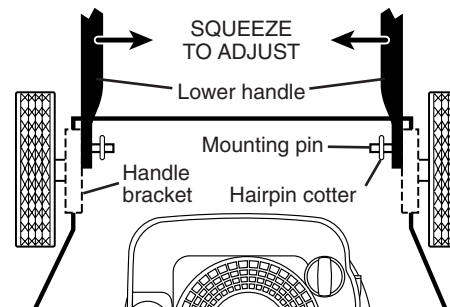

ENGINE ENGINE SPEED

Your engine speed has been factory set. Do not attempt to increase engine speed or it may result in personal injury. If you believe that the engine is running too fast or too slow, take your lawn mower to a Sears or other qualified service centre for repair and adjustment.

CARBURETOR

Your carburetor is not adjustable. If your engine does not operate properly due to suspected carburetor problems, take your lawn mower to a Sears or other qualified service centre for repair or adjustment. **IMPORTANT:** Never tamper with the engine governor, which is factory set for proper engine speed. Overspeeding the engine above the factory high speed setting can be dangerous. If you think the engine-governed high speed needs adjusting, contact a Sears or other qualified service centre, which has proper equipment and experience to make any necessary adjustments.