

Get it fixed, at your home or ours!

Just Call:

1-800-4-MY-HOME®

(1-800-469-4663)

24 hours a day, 7 days a week

For the repair of major brand appliances **in your own home...**
no matter who made it, no matter who sold it!

For your nearest **Sears Parts and Service** location,
to bring in products like vacuums, lawn equipment and electronics.

For **Sears Parts & Service**, to order the replacement parts,
accessories and owner's manuals that you need to do-it-yourself.

www.sears.ca

To purchase or inquire about a Sears Maintenance Agreement, call:

1-800-361-6665

9 a.m. – 11 p.m. Mon. – Fri., EST, 9 a.m. – 4 p.m. Sat.

Pour service en français:

1-800-LE-FOYER^{MC}

(1-800-533-6937)

www.sears.ca



® / TM Trademarks of Sears, Roebuck and Co. used under license by Sears Canada

^{MD} Marque déposée / ^{MC} Marque de commerce de Sears, Roebuck and Co. utilisée en vertu d'une licence de Sears Canada

Owner's Manual



ROTARY LAWN MOWER

675 Series Briggs & Stratton Engine

Power-Propelled

Electric Start

21" Multi-Cut

Model No.

944.367642

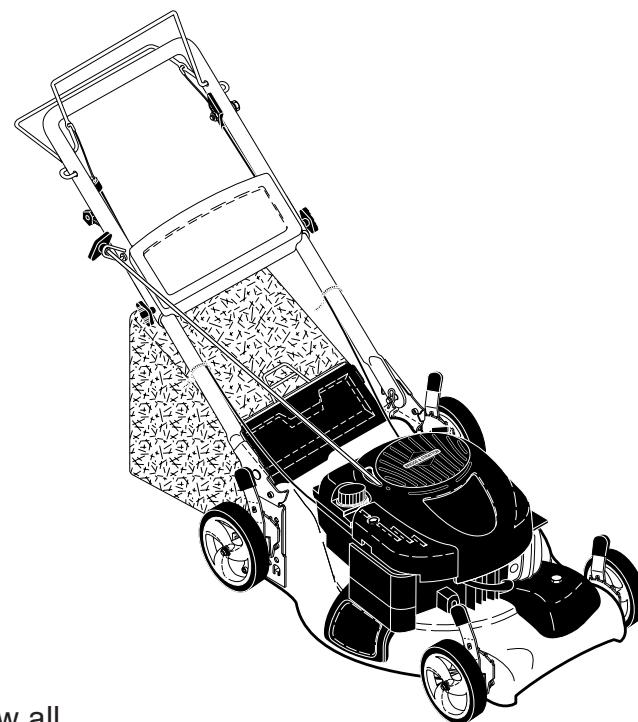

CAUTION:

Read and follow all
Safety Rules and Instructions
before operating this equipment

Sears Canada, Inc., Toronto, Ontario M5B 2B8

TABLE OF CONTENTS

Warranty	2	Maintenance	11-14
Safety Rules	2-4	Service and Adjustments	14-16
Product Specifications	4	Storage	16-17
Assembly/Pre-Operation	4-5	Troubleshooting	17-18
Operation	6-10	Repair Parts	20-28
Maintenance Schedule	11	Sears Service	Back Cover

WARRANTY

LIMITED TWO YEAR WARRANTY ON CRAFTSMAN POWER MOWER

For Two years from date of purchase Sears Canada, Inc. will repair or replace at Sears option free of charge parts which are defective as a result of material or workmanship.

COMMERCIAL OR RENTAL USE:

Warranty on Power Mower (Gas) will be ninety (90) days from date of purchase if used for commercial or rental purposes.

This Warranty does NOT cover:

- Pre-delivery set-up.
- Expendable items which become worn during normal use, such as rotary mower blades, blade adapters, belts, air cleaners and spark plug.
- Repairs necessary because of operator abuse or negligence, including bent crankshafts and the failure to maintain the equipment according to the instructions contained in the owner's manual.
- In-home service.

Warranty service is available by returning the Craftsman Power Mower to the nearest Sears Service Centre/Department in Canada. This warranty applies only while this product is used in Canada.

This warranty is in addition to any statutory warranty and does not exclude or limit legal rights you may have but shall run concurrently with applicable provincial legislation. Furthermore, some provinces do NOT allow limitation on how long an implied warranty will last so the above limitations may not apply to you.

Sears Canada, Inc., Toronto, Ontario M5B 2B8

SAFETY RULES

IMPORTANT: This cutting machine is capable of amputating hands and feet and throwing objects. Failure to observe the following safety instructions could result in serious injury or death.

⚠ Look for this symbol to point out important safety precautions. It means CAUTION!!! BECOME ALERT!!! YOUR SAFETY IS INVOLVED.

⚠ **WARNING:** In order to prevent accidental starting when setting up, transporting, adjusting or making repairs, always disconnect spark plug wire and place wire where it cannot come in contact with plug.

⚠ **CAUTION:** Muffler and other engine parts become extremely hot during operation and remain hot after engine has stopped. To avoid severe burns on contact, stay away from these areas.



I. GENERAL OPERATION

- Read, understand, and follow all instructions on the machine and in the manual(s) before starting. Be thoroughly familiar with the controls and the proper use of the machine before starting.
- Do not put hands or feet near or under rotating parts. Keep clear of the discharge opening at all times.
- Only allow responsible individuals, who are familiar with the instructions, to operate the machine.
- Clear the area of objects such as rocks, toys, wire, bones, sticks, etc., which could be picked up and thrown by blade.
- Be sure the area is clear of other people before mowing. Stop machine if anyone enters the area.

SERVICE NOTES

- Do not operate the mower when barefoot or wearing open sandals. Always wear substantial foot wear.
- Do not pull mower backwards unless absolutely necessary. Always look down and behind before and while moving backwards.
- Never direct discharged material toward anyone. Avoid discharging material against a wall or obstruction. Material may ricochet back toward the operator. Stop the blade when crossing gravel surfaces.
- Do not operate the mower without proper guards, plates, grass catcher or other safety protective devices in place.
- See manufacturer's instructions for proper operation and installation of accessories. Only use accessories approved by the manufacturer.
- Stop the blade(s) when crossing gravel drives, walks, or roads.
- Stop the engine (motor) whenever you leave the equipment, before cleaning the mower or unclogging the chute.
- Shut the engine (motor) off and wait until the blade comes to complete stop before removing grass catcher.
- Mow only in daylight or good artificial light.
- Do not operate the machine while under the influence of alcohol or drugs.
- Never operate machine in wet grass. Always be sure of your footing: keep a firm hold on the handle; walk, never run.
- Disengage the self-propelled mechanism or drive clutch on mowers so equipped before starting the engine.
- If the equipment should start to vibrate abnormally, stop the engine (motor) and check immediately for the cause. Vibration is generally a warning of trouble.
- Always wear safety goggles or safety glasses with side shields when operating mower.

II. SLOPE OPERATION

Slopes are a major factor related to slip & fall accidents which can result in severe injury. All slopes require extra caution. If you feel uneasy on a slope, do not mow it.

DO:

- Mow across the face of slopes: never up and down. Exercise extreme caution when changing direction on slopes.
- Remove obstacles such as rocks, tree limbs, etc.
- Watch for holes, ruts, or bumps. Tall grass can hide obstacles.

DO NOT:

- Do not trim near drop-offs, ditches or embankments. The operator could lose footing or balance.
- Do not trim excessively steep slopes.
- Do not mow on wet grass. Reduced footing could cause slipping.

III. CHILDREN

Tragic accidents can occur if the operator is not alert to the presence of children. Children are often attracted to the machine and the mowing activity. *Never* assume that children will remain where you last saw them.

- Keep children out of the trimming area and under the watchful care of another responsible adult.
- Be alert and turn machine off if children enter the area.
- Before and while walking backwards, look behind and *down* for small children.
- Never allow children to operate the machine.
- Use extra care when approaching blind corners, shrubs, trees, or other objects that may obscure vision.

IV. SAFE HANDLING OF GASOLINE

Use extreme care in handling gasoline. Gasoline is extremely flammable and the vapors are explosive.

- Extinguish all cigarettes, cigars, pipes and other sources of ignition.
- Use only an approved container.
- Never remove gas cap or add fuel with the engine running. Allow engine to cool before refueling.
- Never refuel the machine indoors.
- Never store the machine or fuel container where there is an open flame, spark or pilot light such as a water heater or on other appliances.
- Never fill containers inside a vehicle, on a truck or trailer bed with a plastic liner. Always place containers on the ground away from your vehicle before filling.
- Remove gas-powered equipment from the truck or trailer and refuel it on the ground. If this is not possible, then refuel such equipment with a portable container, rather than from a gasoline dispenser nozzle.
- Keep the nozzle in contact with the rim of the fuel tank or container opening at all times until fueling is complete. Do not use a nozzle lock-open device.
- If fuel is spilled on clothing, change clothing immediately.

- Never overfill fuel tank. Replace gas cap and tighten securely.

V. GENERAL SERVICE

- Never run machine inside a closed area.
- Never make adjustments or repairs with the engine (motor) running. Disconnect the spark plug wire, and keep the wire away from the plug to prevent accidental starting.
- Keep nuts and bolts, especially blade attachment bolts, tight and keep equipment in good condition.
- Never tamper with safety devices. Check their proper operation regularly.
- Keep machine free of grass, leaves, or other debris build-up. Clean oil or fuel spillage. Allow machine to cool before storing.

- Stop and inspect the equipment if you strike an object. Repair, if necessary, before restarting.
- Never attempt to make wheel height adjustments while the engine is running.
- Grass catcher components are subject to wear, damage, and deterioration, which could expose moving parts or allow objects to be thrown. Frequently check components and replace with manufacturer's recommended parts, when necessary.
- Mower blades are sharp and can cut. Wrap the blade(s) or wear gloves, and use extra caution when servicing them.
- Do not change the engine governor setting or overspeed the engine.
- Maintain or replace safety and instruction labels, as necessary.

▲WARNING: This lawn mower is equipped with an internal combustion engine and should not be used on or near any unimproved forest-covered, brush-covered or grass-covered land unless the engine's exhaust system is equipped with a spark arrester meeting applicable local or state laws (if any). If a spark arrester is used, it should be maintained in effective working order by the operator. A spark arrester for the muffler is available through your nearest Sears Service Centre (See the REPAIR PARTS section of this manual).

PRODUCT SPECIFICATIONS

Serial Number:	
Date of Purchase:	
Gasoline Capacity / Type:	1,4 Liters (Unleaded Regular)
Oil Type (API SG–SL):	SAE 30 (above 32°F/0°C); SAE 5W-30 (below 32°F/0°C)
Oil Capacity:	0,57 Liters
Spark Plug:	Champion RJ19HX (Gap: 0,76 mm)
Blade Bolt Torque:	35-40 ft. lbs. / 47-54 N-m
<ul style="list-style-type: none"> • The model and serial numbers will be found on a decal on the rear of the mower housing. Record both serial number and date of purchase in space provided above. 	

ASSEMBLY / PRE-OPERATION

Read these instructions and this manual in its entirety before you attempt to assemble or operate your new lawn mower.

IMPORTANT: This lawn mower is shipped WITHOUT OIL OR GASOLINE in the engine.

Your new lawn mower has been assembled at the factory with the exception of those parts left unassembled for shipping purposes. All parts such as nuts, washers, bolts, etc., necessary to complete the assembly have been placed in the parts bag. To ensure safe and proper operation of your lawn mower, all parts and hardware you assemble must be tightened securely. Use the correct tools as necessary to ensure proper tightness.

BRIGGS & STRATTON 4-CYCLE ENGINE

MODEL NUMBER 126T05-0880-B2

KEY NO.	PART NO.	DESCRIPTION	KEY NO.	PART NO.	DESCRIPTION
510	494147	Drive-Starter	870	690380	Seat-Valve (Exhaust)
513	692358	Clutch-Drive	871	262001	Bushing-Guide (Exhaust)
523	499621	Dipstick		63709	Bushing-Guide (Intake)
524	692296	• Seal-Dipstick Tube	883	691881	• Gasket-Exhaust
525	495265	Tube-Dipstick	922	691831	Spring-Brake
529	691923	Grommet	923	691994	Brake
544	690786	Armature-Starter	935	499421	Switch-Interlock
545	492919	Washer Set	937	691325	Spline-Starter
562	691119	Bolt (Governor Control Lever)	957	699985	Cap-Fuel Tank
		Screw (Control Cover)	966	792040	Base-Air Cleaner Primer
564	698589	Cover-Breather Passage	968	692298	Cover-Air Cleaner
584	697734	• Gasket-Breather Passage	969	690700	Screw (Blower Housing Cover)
585	691879	Nut (Rewind Starter)	972	699374	Tank-Fuel
592	690800	Screw (Pawl Friction Plate)	975	493640	Bowl-Float
597	691696	Clamp-Hose	976	694394	Primer-Carburetor
601	791850	Cover-Control	977	498261	Set-Carburetor Gasket
604	790703	Starter-Rewind	1036	792156	Label-Emissions
608	497680	Screw (Muffler)	1059	692311	Kit-Screw/Washer
613	790833	Retainer-Governor Shaft	1160	691627	Screw (Interlock Switch)
615	690340	Crank-Governor	1210	498144	Assembly-Pulley/Spring (Pulley)
616	698801	Seal (Intake Manifold)	1211	498144	Assembly-Pulley/Spring (Spring)
617	270344s*Ø‡	Switch-Stop			
621	692310	Ø‡ Seal-Throttle Shaft			
633	691321	Seal-Choke Shaft	1329	126T07-0662	Replacement Engine (Replacement Engine not available in the State of California. Repair with individual parts. The original engine was equipped with a special spark plug boot and armature assembly. Armature assembly must be transferred to the replacement engine.)
633A	693867	Boot-Spark Plug			
635	793351	Screw (Starter Gear Cover)			
651	690345	• Spacer (Includes 2)			
668	493823	Spacer-Fuel Tank			
670	692294	Screw (Breather Cover)			
684	690345	Spring-Friction			
689	691855	Screw (Drive Cap)			
697	691127	Pin-Locating	1330	270962	Repair Manual
718	690959	Gear-Timing	1386	790848	Vane-Air
741	790345	Retainer-E Ring	1387	790849	Spring-Air Vane
742	93941	Screw (Brake)	1388	790850	Screw (Air Vane)
745	691648	Gear-Pinion			
783	691269	Gear-Pinion	- -	398067	Spark Arrester (available accessory)
783A	691918	Cover-Starter Gear			
784	692341	Harness-Wiring			
789	696547	Cap-Drive			
801	690782	Cap-End			
802	695267	Housing-Starter			
803	695266	• Seal-O Ring (Dipstick Tube)			
842	691031	Assembly-Dipstick/Tube	Ø		Included in Carb. Overhaul Kit, Key No. 121
847	692047	Terminal-Spark Plug	‡		Included in Carb. Gasket Set, Key No. 977
851	692424	Seal-Valve			
868	697338	Seat-Valve (Intake)			
869	691155				

NOTE: All component dimensions given in U.S. inches. 1 inch = 25.4 mm

KEY NO.	PART NO.	DESCRIPTION	KEY NO.	PART NO.	DESCRIPTION
1	697322	Cylinder Assembly	108	790844	Valve-Choke
2	399269	Kit-Bushing/Seal	109	790843	Shaft-Choke
3	299819s	• Seal-Oil (Magneto Side)	117	691428	Jet-Main (Standard)
4	493279	Sump-Engine	118	695042	Jet-Main (High Altitude)
5	691160	Head-Cylinder	121	498260	Kit-Carburetor Overhaul
7	692249	• Gasket-Cylinder Head	125	794304	Carburetor
8	695250	Breather Assembly	127	694468	Ø Plug-Welch
9	696125	Gasket-Breather	130	696564	Valve-Throttle
10	691125	Screw (Breather Assembly)	133	398187	Float-Carburetor
11	691781	Tube-Breather	134	398188	Ø Valve-Needle/Seat
12	692232	• Gasket-Crankcase	137	693981	Ø‡ Gasket-Float Bowl
13	690912	Screw (Cylinder Head)	163	272653s	•Ø‡ Gasket-Air Cleaner
15	691680	Plug-Oil Drain	187	791783	Line-Fuel (Molded)
16	691450	Crankshaft	188	693399	Screw (Control Bracket)
20	399781s	• Seal-Oil (PTO Side)	190	690940	Screw (Fuel Tank)
22	691092	Screw (Engine Sump)	202	691829	Link-Mechanical Governor
23	691987	Flywheel	209	699056	Spring-Governor
24	222698s	Key-Flywheel	222	793754	Bracket-Control
25	791097	Piston Assembly (Standard)	227	690783	Control Lever-Governor
	791326	Piston Assembly (.020" Oversize)	231	690718	Screw (Choke Valve)
		Ring Set (Standard)	276	271716	Ø‡ Sealing Washer
26	791098	Ring Set (.020" Oversize)	287	690940	Screw (Dipstick Tube)
	791324	Ring Set (.020" Oversize)	291	790830	Thermostat
27	691866	Lock-Piston Pin	300	790828	Muffler
28	499423	Pin-Piston	304	791135	Housing-Blower
29	499424	Rod-Connecting	305	691108	Screw (Blower Housing)
32	691664	Screw (Connecting Rod)	306	790836	Shield-Cylinder
32A	695759	Screw (Connecting Rod)	307	690345	Screw (Cylinder Shield)
33	262651s	Valve-Exhaust	309	695550	Motor-Starter
34	262652s	Valve-Intake	310	692327	Screw (Starter Motor)
35	691270	Spring-Valve (Intake)	332	690662	Nut (Flywheel)
36	691270	Spring-Valve (Exhaust)	333	793353	Armature-Magneto
40	692194	Retainer-Valve	334	691061	Screw (Armature Magneto)
43	691997	Slinger-Governor/Oil	337	802592s	Plug-Spark
45	690548	Tappet-Valve	356	692390	Wire-Stop
46	691449	Camshaft	358	794307	Engine Gasket Set
48	792741	Short Block	363	19069	Flywheel Puller
50	794305	Manifold-Intake	365	692524	Screw (Carburetor)
51	794306	• Gasket-Intake	383	89838s	Wrench-Spark Plug
54	691650	Screw (Intake Manifold)	404	690272	Washer (Governor Crank)
55	691421	Housing-Rewind Starter	425	690670	Screw (Air Cleaner Cover)
58	697316	Rope-Starter (Cut to Required Length)	443	692523	Screw (Air Cleaner Primer Base)
60	281434s	Grip-Starter Rope	445	491588s	Filter-Air Cleaner Cartridge
65	690837	Screw (Rewind Starter)	455	791960	Cup-Flywheel
81	691740	Lock-Muffler Screw	456	692299	Plate-Pawl Friction
97	696565	Shaft-Throttle	459	281505s	Pawl-Ratchet
104	691242	Ø Pin-Float Hinge	505	691251	Nut (Gov. Control Lever)

TO REMOVE LAWN MOWER FROM CARTON

1. Remove loose parts included with mower.
2. Cut down two end corners of carton and lay end panel down flat.
3. Remove all packing materials except padding between upper and lower handle and padding holding operator presence control bar to upper handle.
4. Roll lawn mower out of carton and check carton thoroughly for additional loose parts.

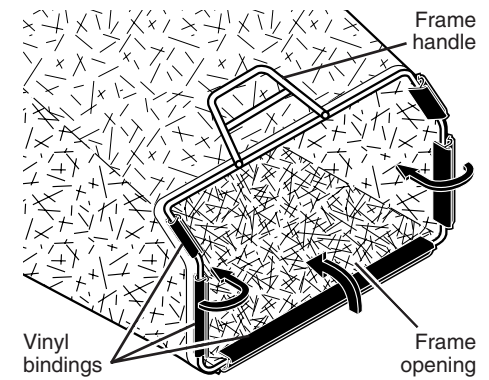

HOW TO SET UP YOUR LAWN MOWER

TO UNFOLD HANDLE

IMPORTANT: Unfold handle carefully so as not to pinch or damage control cables.

1. Raise handles until lower handle section locks into place in mowing position.
2. Remove protective padding, raise upper handle section into place on lower handle and tighten both handle knobs.
3. Remove handle padding holding operator presence control bar to upper handle.

Your lawn mower handle can be adjusted for your mowing comfort. Refer to "ADJUST HANDLE" in the Service and Adjustments section of this manual.

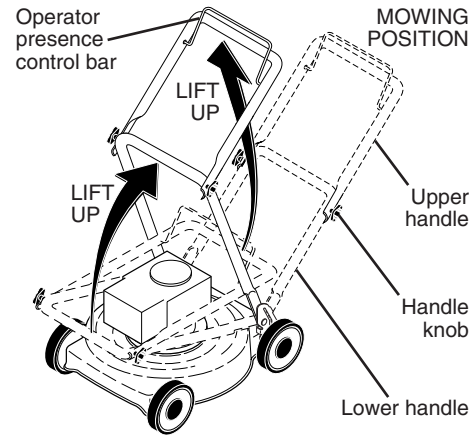

TO ASSEMBLE GRASS CATCHER

1. Put grass catcher frame into grass bag with rigid part of bag on the bottom. Make sure the frame handle is outside of the bag top.
2. Slip vinyl bindings over frame.

NOTE: If vinyl bindings are too stiff, hold them in warm water for a few minutes. If bag gets wet, let it dry before using.

TO PREPARE BATTERY

NOTE: Your battery must be charged before you can start your lawn mower.

1. Connect battery charger connector (male) to harness connector (female).
2. Plug battery charger into 110 volt A.C. outlet.
3. Leave battery charger connected for 24 hours before starting your engine for the first time.
4. After charging, disconnect harness connector (female) from battery charger connector (male).

Connect your battery charger to charge battery after each use.

IMPORTANT: The engine will not recharge your battery.

At the end of the mowing season the battery should be charged for 48 hours to protect the battery during winter storage.

CAUTION: Always disconnect the engine connector (male) from the battery connector (female) to prevent accidental starting when transporting or storing your lawn mower after the season.

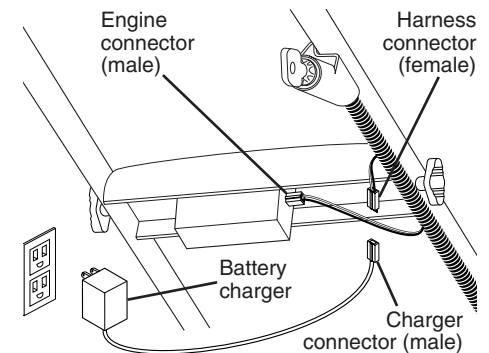

TO INSTALL ATTACHMENTS

Your lawn mower was shipped ready to be used as a mulcher. To convert to bagging or discharging, see "TO CONVERT MOWER" in the Operation section of this manual.

OPERATION

KNOW YOUR LAWN MOWER

READ THIS OWNER'S MANUAL AND ALL SAFETY RULES BEFORE OPERATING YOUR LAWN MOWER. Compare the illustrations with your lawn mower to familiarize yourself with the location of various controls and adjustments. Save this manual for future reference.

These symbols may appear on your lawn mower or in literature supplied with the product. Learn and understand their meaning.

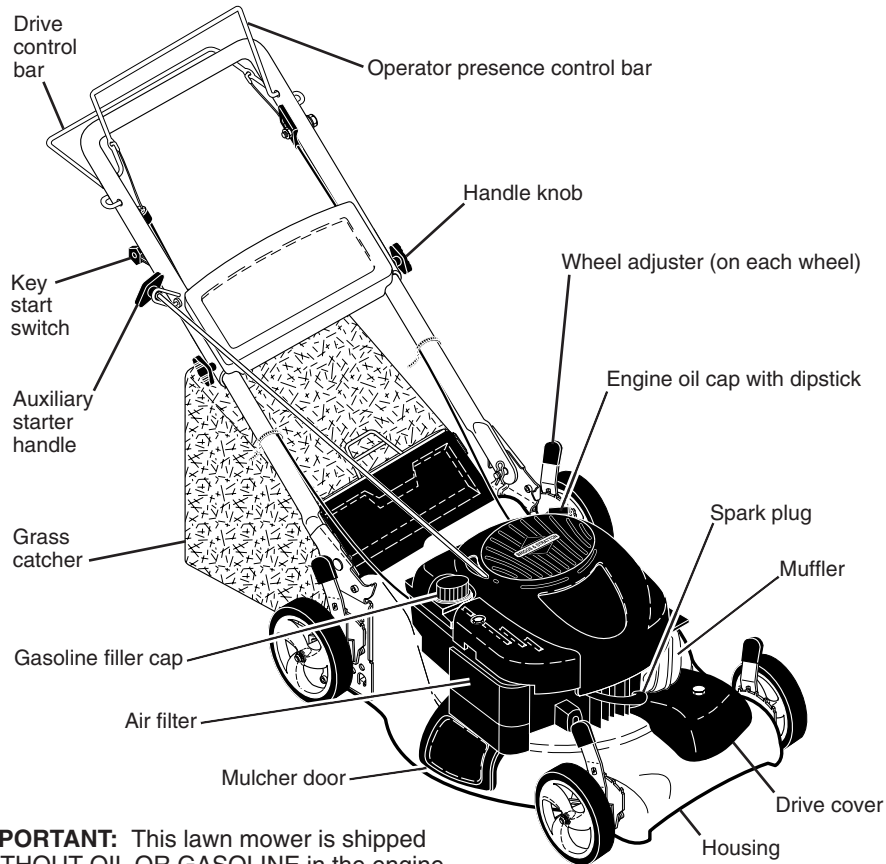
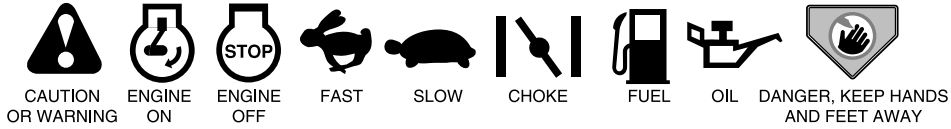

IMPORTANT: This lawn mower is shipped WITHOUT OIL OR GASOLINE in the engine.

MEETS CPSC SAFETY REQUIREMENTS

Sears rotary walk-behind power lawn mowers conform to the safety standards of the American National Standards Institute and the U.S. Consumer Product Safety Commission. The blade turns when the engine is running.

Operator presence control bar – must be held down to the handle to start the engine. Release to stop the engine.

Drive control bar – used to engage power-propelled forward motion of mower.

Key start switch – used for starting engine.

Auxiliary starter handle – used for starting the engine.

Mulcher door – allows conversion to discharging or bagging operation.

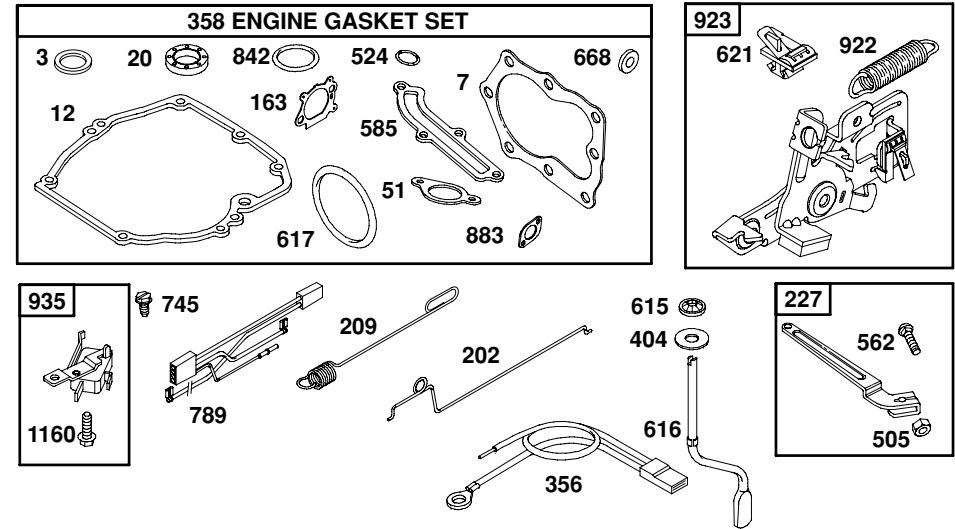

Engine Power Rating Information

The gross power rating for individual gas engine models is labeled in accordance with SAE (Society of Automotive Engineers) code J11940 (Small Engine Power & Torque Rating Procedure), and rating performance has been obtained and corrected in accordance with SAE J1995 (Revision 2002-5). Actual gross engine power will be lower and is affected by, among other things, ambient operating conditions and engine-to-engine variability. Given both the wide array of products on which engines are placed and the variety of environmental issues applicable to operating the equipment, the gas engine will not develop the rated gross power when used in a given piece of power equipment (actual "on-site" or net horsepower). This difference is due to a variety of factors including, but not limited to, accessories (air cleaner, exhaust, charging, cooling, carburetor, fuel pump, etc.), application limitations, ambient operating conditions (temperature, humidity, altitude), and engine-to-engine variability. Due to manufacturing and capacity limitations, Briggs & Stratton may substitute an engine of higher rated power for this Series engine.

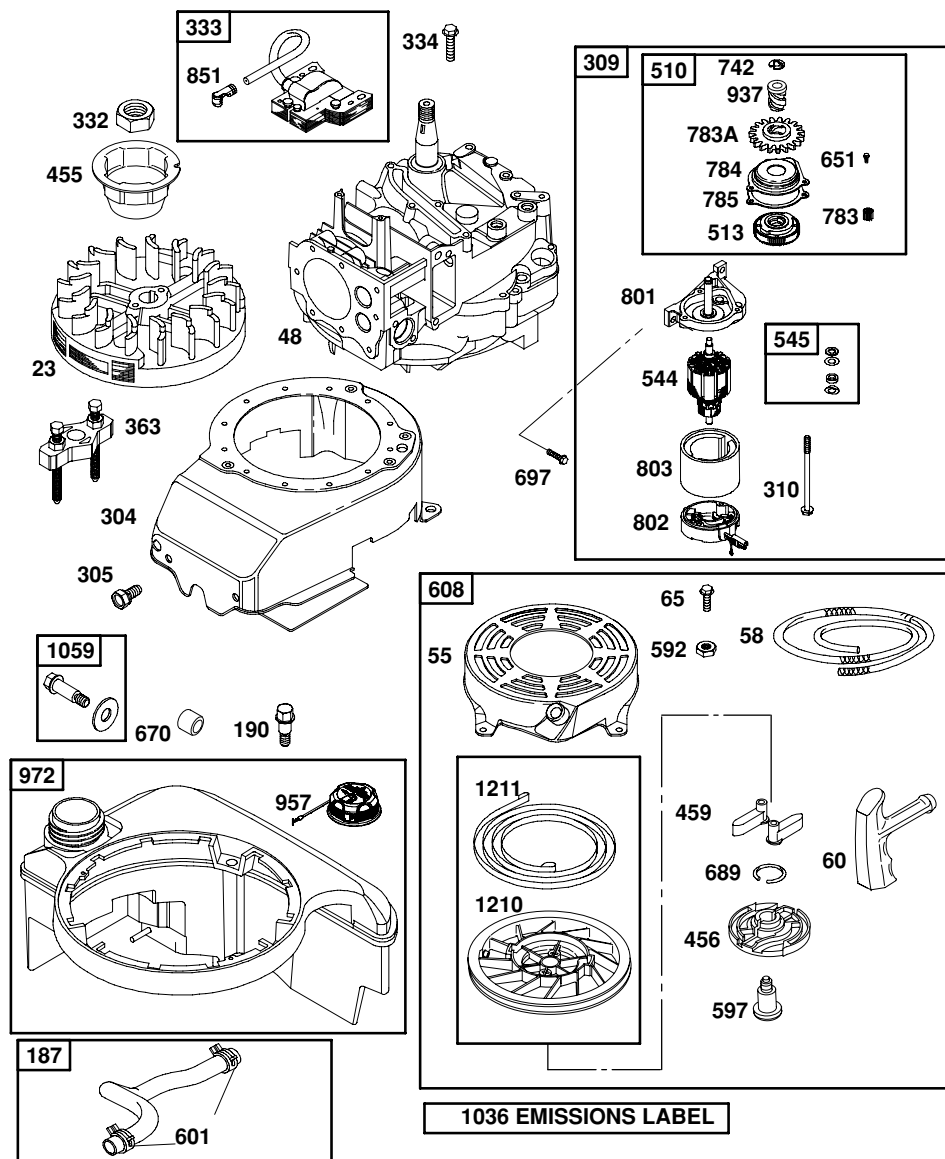

The operation of any lawn mower can result in foreign objects thrown into the eyes, which can result in severe eye damage. Always wear safety glasses or eye shields while operating your lawn mower or performing any adjustments or repairs. We recommend standard safety glasses or a wide vision safety mask worn over spectacles.

HOW TO USE YOUR LAWN MOWER ENGINE SPEED

The engine speed was set at the factory for optimum performance. It is not adjustable.

ENGINE ZONE CONTROL

CAUTION: Federal regulations require an engine control to be installed on this lawn mower in order to minimize the risk of blade contact injury. Do not under any circumstances attempt to defeat the function of the operator control. The blade turns when the engine is running.

- Your lawn mower is equipped with an operator presence control bar which requires the operator to be positioned behind the lawn mower handle to start and operate the lawn mower.

DRIVE CONTROL

- Self-propelling is controlled by holding the operator presence control bar down to the handle and pulling the drive control bar up to the handle. The closer to the handle the bar is pulled, the faster the unit will travel.
- Forward motion will stop when either the operator presence control bar or drive control bar are released. To stop forward motion without stopping engine, release the drive control bar only. Hold operator presence control bar down against handle to continue mowing without self-propelling.

NOTE: If after releasing the drive control the mower will not roll backwards, push the mower forward slightly to disengage drive wheels.

- To keep drive control engaged when turning corners, push down on the handle to lift the front wheels off the ground while turning lawn mower.

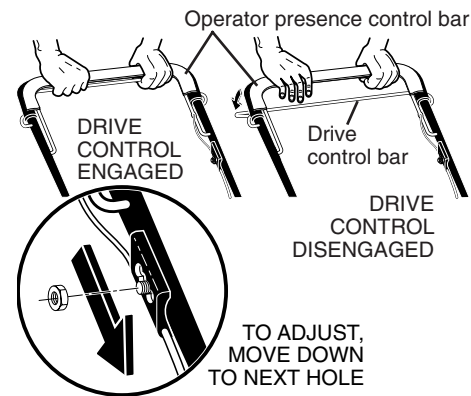

DRIVE CONTROL ADJUSTMENT

Over time, the drive control system may become "loose", resulting in decreased speed. There are holes in the drive control housing to increase tension on the drive cable. Proceed as follows:

- Turn unit off and disconnect spark plug wire from spark plug.
- Loosen nut, move drive control housing down handle to the next hole and retighten nut.
- Operate mower to test drive speed.
- If condition fails to improve after the above steps (forward speed remains the same), your drive belt is worn and should be replaced.

TO ADJUST CUTTING HEIGHT

Raise wheels for low cut and lower wheels for high cut, adjust cutting height to suit your requirements. Medium position is best for most lawns.

- To change cutting height, squeeze adjuster lever toward wheel. Move wheel up or down to suit your requirements. Be sure all wheels are in the same setting.

NOTE: Adjuster is properly positioned when plate tab inserts into hole in lever. Also, 9-position adjusters (if so equipped) allow lever to be positioned between the plate tabs.

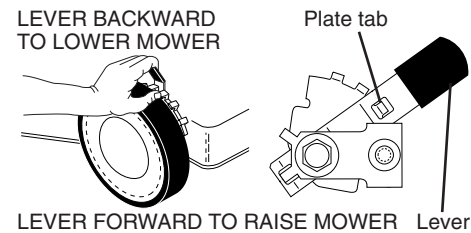

TO CONVERT MOWER

Your lawn mower was shipped ready to be used as a mulcher. To convert to bagging or discharging:

REAR BAGGING

- Lift rear door of the lawn mower and place the grass catcher frame hooks onto the door pivot pins.
- To convert to mulching or discharging operation, remove grass catcher and close rear door.

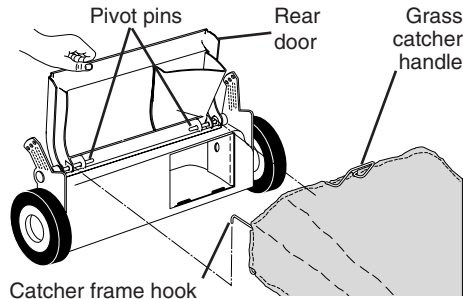

SIDE DISCHARGING

- Rear door must be closed.
- Open mulcher door and install discharge deflector under door as shown.
- Mower is now ready for discharging operation.
- To convert to mulching or bagging operation, discharge deflector must be removed and mulcher door must be closed.

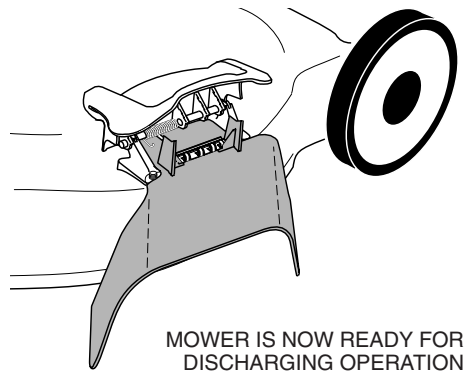
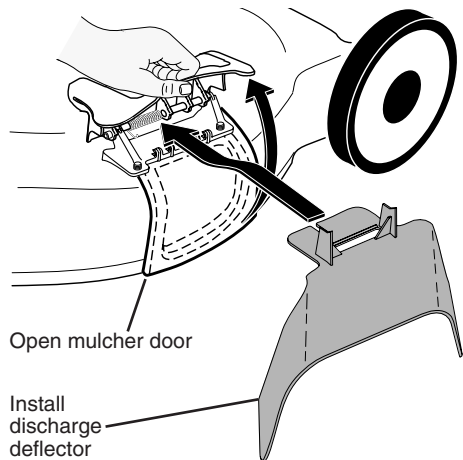

MOWER IS NOW READY FOR DISCHARGING OPERATION

SIMPLE STEPS TO REMEMBER WHEN CONVERTING YOUR LAWN MOWER

FOR MULCHING -

1. Rear door closed.
2. Mulcher door closed.

FOR REAR BAGGING -

1. Grass catcher installed.
2. Mulcher door closed.

FOR SIDE DISCHARGING -

1. Rear door closed.
2. Discharge deflector installed.

CAUTION: Do not run your lawn mower without rear door closed or approved grass catcher in place. Never attempt to operate the lawn mower with the rear door removed or propped open.

TO EMPTY GRASS CATCHER

1. Lift up on grass catcher using the frame handle.
2. Remove grass catcher with clippings from under lawn mower handle.
3. Empty clippings from bag.

NOTE: Do not drag the bag when emptying; it will cause unnecessary wear.

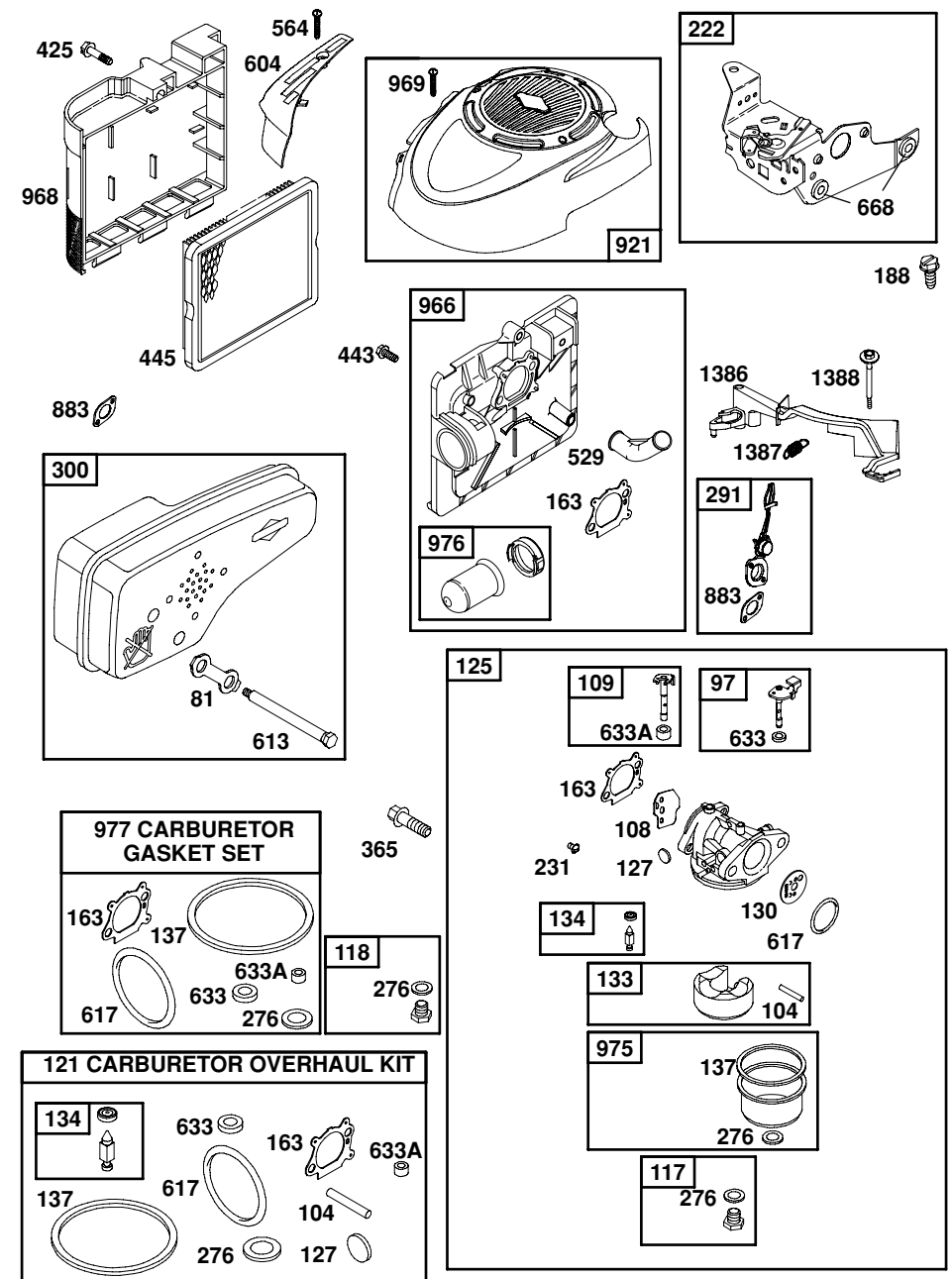
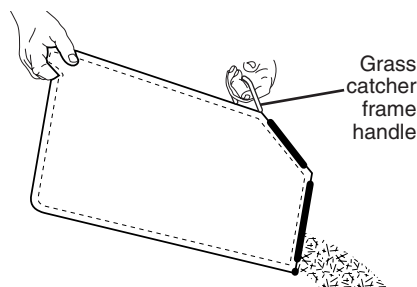

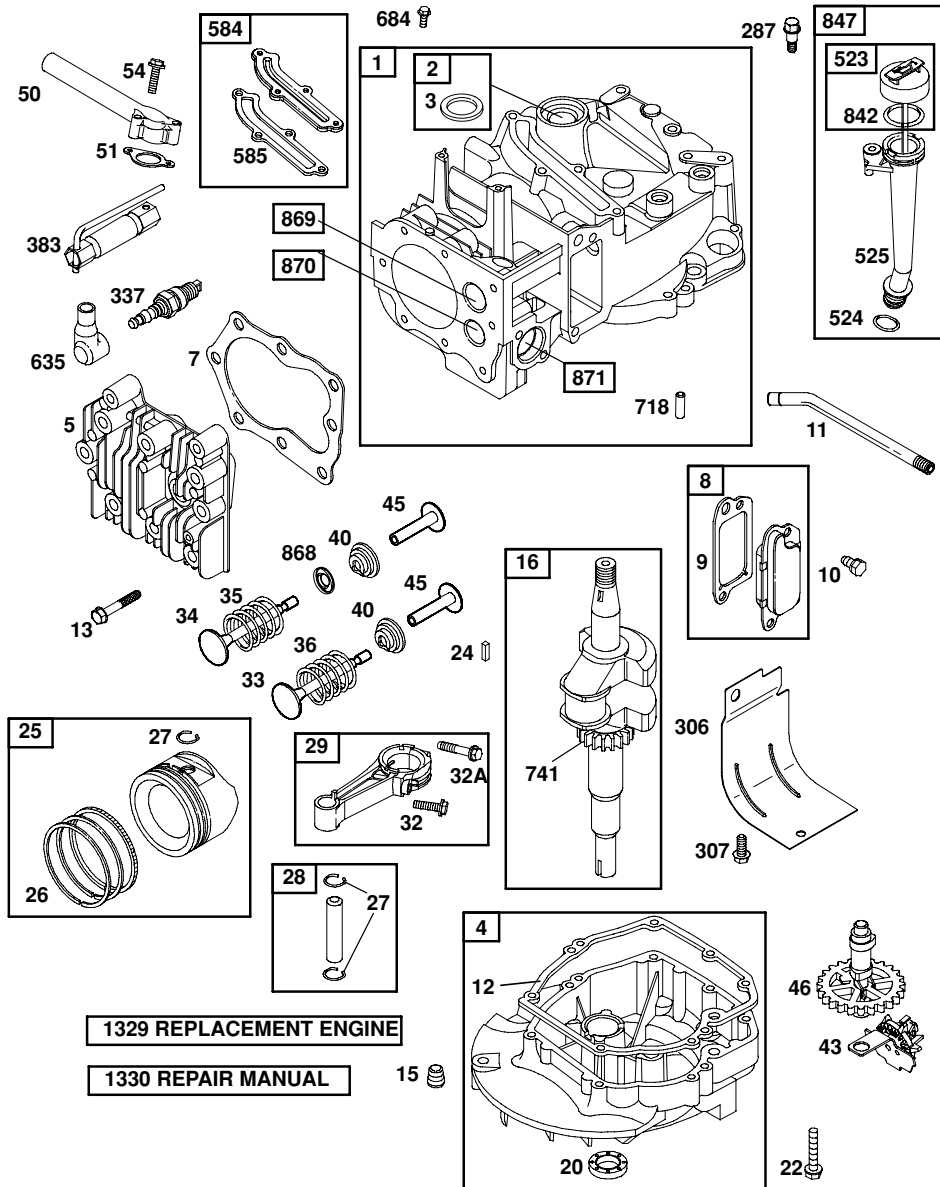

BEFORE STARTING ENGINE ADD OIL

Your lawnmower is shipped without oil in the engine. For type and grade of oil to use, see "ENGINE" in the Maintenance section of this manual.

CAUTION: DO NOT overfill engine with oil, or it will smoke heavily from the muffler on startup.

1. Be sure lawnmower is level.
2. Remove oil dipstick from oil fill spout.
3. You receive a container of oil with the unit. Slowly pour the entire container down the oil fill spout into the engine.

NOTE: Initial oil fill requires only 18 oz. due to residual oil in engine from the manufacturers 100% quality testing. When changing oil you may need 20 oz.

4. Insert and tighten dipstick.

IMPORTANT:

- Check oil level before each use. Add oil if needed. Fill to full line on dipstick.
- Change the oil after every 25 hours of operation or each season. You may need to change the oil more often under dusty, dirty conditions. See "TO CHANGE ENGINE OIL" in the Maintenance section of this manual.

ATTACH FUEL CAP CARTRIDGE

Your mower is equipped with a special *FRESH START™* fuel cap and continuous fuel preserver cartridge. See the information and instructions packed with the *FRESH START™* cartridge.

1. Snap cartridge into bottom of fuel cap.
- NOTE:** Do not remove the silver foil seal on the side of cartridge that snaps into fuel cap.
2. Grasp the white peel tab and pull to remove the entire seal.
3. Screw fuel cap onto fuel tank after filling tank with gasoline.

Replace cartridge when empty (about once a season). Check preserver level visually.

DANGER: Cartridge fluid is HARMFUL OR FATAL IF SWALLOWED. Avoid contact to eyes, skin, or clothing. Do not take internally. Do not inhale fluid vapor. Keep out of reach of children. If swallowed, call a physician immediately.

ADD GASOLINE

- Fill fuel tank to bottom of tank filler neck. Do not overfill. Use fresh, clean, regular unleaded gasoline with a minimum of 87 octane. Do not mix oil with gasoline. Purchase fuel in quantities that can be used within 30 days to assure fuel freshness.

CAUTION: Wipe off any spilled oil or fuel. Do not store, spill or use gasoline near an open flame.

CAUTION: Alcohol blended fuels (called gasohol or using ethanol or methanol) can attract moisture which leads to separation and formation of acids during storage. Acidic gas can damage the fuel system of an engine while in storage. To avoid engine problems, the fuel system should be emptied before storage of 30 days or longer. Empty the gas tank, start the engine and let it run until the fuel lines and carburetor are empty. Use fresh fuel next season. See Storage Instructions for additional information. Never use engine or carburetor cleaner products in the fuel tank or permanent damage may occur.

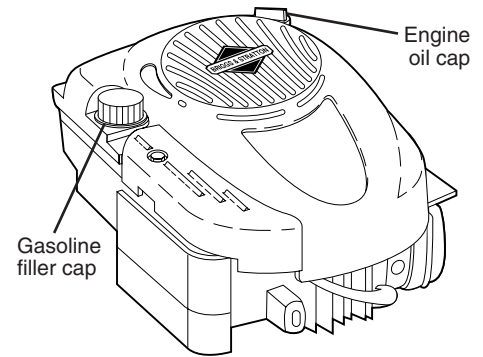

TO STOP ENGINE

- To stop engine, release operator presence control bar.

TO START ENGINE

NOTE: Due to protective coatings on the engine, a small amount of smoke may be present during the initial use of the product and should be considered normal.

NOTE: Your engine is equipped with an automatic choke system. No priming or choking is required before starting.

- To start engine, hold operator presence control bar down to the handle and turn the start key.

IMPORTANT: Do not crank engine more than five continuous seconds between each time you try to start. Wait 5 to 10 seconds between each attempt.

- To start engine using the rope starter, hold operator presence control bar down to the handle and pull starter handle quickly. Do not allow starter rope to snap back.

MOWING TIPS

⚠ CAUTION: Do not use de-thatcher blade attachments on your mower. Such attachments are hazardous, will damage your mower and could void your warranty.

- Under certain conditions, such as very tall grass, it may be necessary to raise the height of cut to reduce pushing effort and to keep from overloading the engine and leaving clumps of grass clippings. It may also be necessary to reduce ground speed and/or run the lawn mower over the area a second time.
- For extremely heavy cutting, reduce the width of cut by overlapping previously cut path and mow slowly.
- For better grass bagging and most cutting conditions, the engine speed should be set in the FAST position.
- When using a rear discharge lawn mower in moist, heavy grass, clumps of cut grass may not enter the grass catcher. Reduce ground speed (pushing speed) and/or run the lawn mower over the area a second time.
- If a trail of clippings is left on the right side of a rear discharge mower, mow in a clockwise direction with a small overlap to collect the clippings on the next pass.
- Pores in cloth grass catchers can become filled with dirt and dust with use and catchers will collect less grass. To prevent this, regularly hose catcher off with water and let dry before using.
- Keep top of engine around starter clear and clean of grass clippings and chaff. This will help engine air flow and extend engine life.

MULCHING MOWING TIPS

IMPORTANT: For best performance, keep mower housing free of built-up grass and trash. See “CLEANING” in the Maintenance section of this manual.

- The special mulching blade will recut the grass clippings many times and reduce them in size so that as they fall onto the lawn they will disperse into the grass and not be noticed. Also, the mulched grass will biodegrade quickly to provide nutrients for the lawn. Always mulch with your highest engine (blade) speed as this will provide the best recutting action of the blades.
- Avoid cutting your lawn when it is wet. Wet grass tends to form clumps and interferes with the mulching action. The best time to mow your lawn is the early afternoon. At this time the grass has dried, yet the newly cut area will not be exposed to direct sunlight.
- For best results, adjust the lawn mower cutting height so that the lawn mower cuts off only the top one-third of the grass blades. If the lawn is overgrown it will be necessary to raise the height of cut to reduce pushing effort and to keep from overloading the engine and leaving clumps of mulched grass. For extremely heavy grass, reduce your width of cut by overlapping previously cut path and mow slowly.

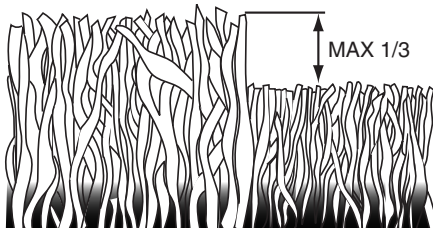

- Certain types of grass and grass conditions may require that an area be mulched a second time to completely hide the clippings. When doing a second cut, mow across (perpendicular) to the first cut path.
- Change your cutting pattern from week to week. Mow north to south one week then change to east to west the next week. This will help prevent matting and graining of the lawn.

CRAFTSMAN ROTARY LAWN MOWER -- MODEL NUMBER 944.367642

KEY PART NO.	DESCRIPTION	KEY PART NO.	DESCRIPTION
1	407816 Drive Control Assembly (Includes Cable)	36	404833 Gear Case Assembly, Complete
4	199687 Screw, Threaded, Rolled #10-24 x 1/2	38	73800400 Locknut 1/4-20
6	194185X615 Control Bar, Drive	40	406558 Spring
7	191730 Locknut, Hex	41	408861 Kit, Wheel Adjuster, RH
11	407755X460 Wheel & Tire Assembly		(Includes Knob and Bearing)
12	12000058 E-Ring	54	410353 Grassbag Assembly
13	403849 Pinion	57	401802 Frame, Grassbag
14	189403 Dust Cover	60	410734 Case, Lower
15	404845 Pawl, Drive	61	410726 Case, Upper
16	67725 Washer 1/2 x 1-1/2 x .134	62	410949 Shaft, Output
17	191039 Bearing, Wheel Adjuster	63	183508 Seal, Output Shaft
18	701037 Selector Knob	64	183511 Bushing
25	404843X004 Belt Keeper	65	183509 Washer
26	163409 Screw, Hi-Lo Thread #12 x 5/8	66	183514 Seal, Worm Shaft
27	175262 Pan Head Tapping Screw #10-24 x 2-3/4	67	183506 Bearing, Ball
28	194404X428 Drive Cover	68	410729 Gear, 28 Teeth
29	175436 V-Belt	69	410732 Fixed Dog Clutch
32	194018 Pulley, Drive	70	410733 Pin
33	409148 Nut, Hex	71	410730 Movable Dog Clutch
35	408862 Kit, Wheel Adjuster, LH	73	183513 Screw, Case
	(Includes Knob and Bearing)	78	410731 Spring, Leaf
		79	410727 Shaft, Worm

IMPORTANT: Use only Original Equipment Manufacturer (O.E.M.) replacement parts. Failure to do so could be hazardous, damage your lawn mower and void your warranty.

NOTE: All component dimensions given in U.S. inches. 1 inch = 25.4 mm.

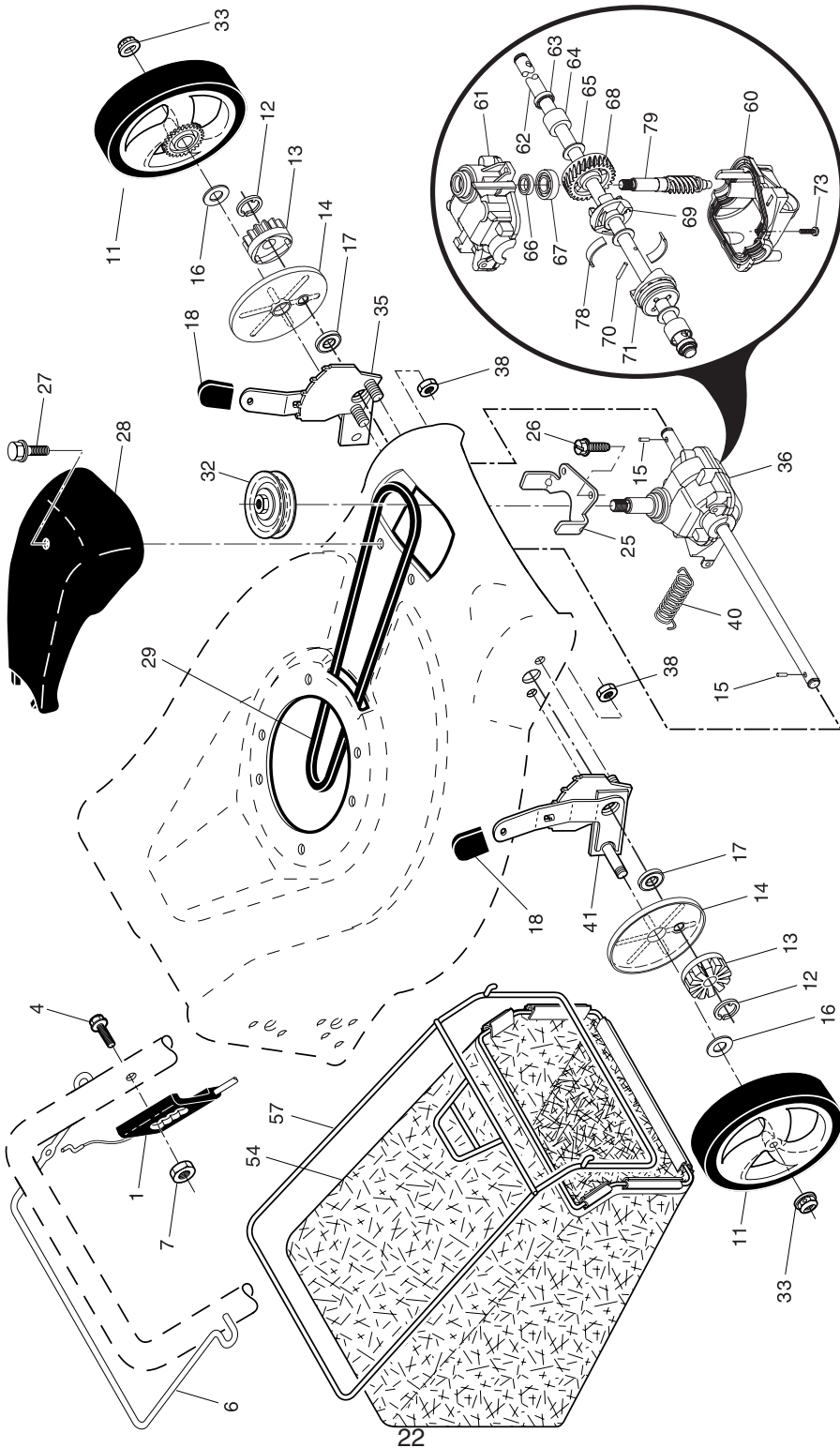

MAINTENANCE

MAINTENANCE SCHEDULE		BEFORE EACH USE	AFTER EACH USE	EVERY 10 HOURS	EVERY 25 HOURS OR SEASON	EVERY 100 HOURS	BEFORE STORAGE
LAWN MOWER	Check for Loose Fasteners	✓					✓
	Clean / Inspect Grass Catcher *	✓	✓				✓
	Check Tires	✓					
	Check Drive Wheels ***	✓					
	Clean Lawn Mower ****		✓				✓
ENGINE	Clean under Drive Cover ***			✓			
	Check Drive Belt / Pulleys ***				✓		
	Check / Sharpen / Replace Blade				✓ ₃		
	Lubrication				✓		
	Clean and Recharge Battery **				✓		✓ ₄
ENGINE	Check Engine Oil level	✓ ₅					
	Change Engine Oil				✓ _{1,2}		
	Clean Air Filter				✓ ₂		
	Inspect Muffler				✓		
	Replace Spark Plug				✓		
	Replace Air Filter Paper Cartridge					✓ ₂	
	Empty fuel system or add Stabilizer						✓

- * (if so equipped)
- ** Electric-Start mowers
- *** Power-Propelled mowers
- **** Use a scraper to clean under deck
- 1 - Change more often if operating under a heavy load or in high outdoor temperatures.
- 2 - Service more often if operating in dirty or dusty conditions.
- 3 - Replace blades more often when mowing in sandy soil.
- 4 - Charge 48 hours at end of season.
- 5 - And after each 5 hours of use.

GENERAL RECOMMENDATIONS

The warranty on this lawn mower does not cover items that have been subjected to operator abuse or negligence. To receive full value from the warranty, operator must maintain unit as instructed in this manual.

Some adjustments will need to be made periodically to properly maintain your unit.

At least once a season, check to see if you should make any of the adjustments described in the Service and Adjustments section of this manual.

- At least once a year, replace the spark plug, clean or replace air filter element and check blade for wear. A new spark plug and clean/new air filter element assure proper air-fuel mixture and help your engine run better and last longer.
- Follow the maintenance schedule in this manual.

BEFORE EACH USE

- Check engine oil level.
- Check for loose fasteners.

LUBRICATION

Keep unit well lubricated (See "LUBRICATION CHART").

LUBRICATION CHART

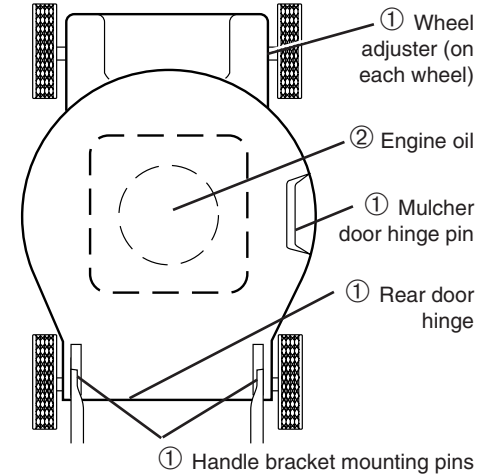

- ① Spray lubricant
- ② See "ENGINE" in Maintenance section.

IMPORTANT: Do not oil or grease plastic wheel bearings. Viscous lubricants will attract dust and dirt that will shorten the life of the self-lubricating bearings. If you feel they must be lubricated, use only a dry, powdered graphite type lubricant sparingly.

LAWN MOWER

Always observe safety rules when performing any maintenance.

TIRES

- Keep tires free of gasoline, oil, or insect control chemicals which can harm rubber.
- Avoid stumps, stones, deep ruts, sharp objects and other hazards that may cause tire damage.

DRIVE WHEELS

Check front drive wheels each time before you mow to be sure they move freely. The wheels not turning freely means trash, grass cuttings, etc. are in the drive wheel area and must be cleaned to free drive wheels.

If necessary to clean the drive wheels, be sure to clean both front wheels.

1. Remove hubcaps, hairpin cotters and washers.
2. Remove wheels from wheel adjusters.
3. Remove any trash or grass cuttings from inside the dust cover, pinion and/or drive wheel gear teeth.
4. Put wheels back in place.

NOTE: If after cleaning, the drive wheels do not turn freely, contact a Sears or other qualified service center.

BLADE CARE

For best results, mower blade must be kept sharp. Replace a bent or damaged blade.

CAUTION: Use only a replacement blade approved by the manufacturer of your mower. Using a blade not approved by the manufacturer of your mower is hazardous, could damage your mower and void your warranty.

TO REMOVE BLADE

1. Disconnect spark plug wire from spark plug and place wire where it cannot come in contact with plug.
2. Turn lawn mower on its side. Make sure air filter and carburetor are up.
3. Use a wood block between blade and mower housing to prevent blade from turning when removing blade bolt.

NOTE: Protect your hands with gloves and/or wrap blade with heavy cloth.

4. Remove blade bolt by turning counter-clockwise.
5. Remove blade and attaching hardware (bolt, lock washer and hardened washer).

NOTE: Remove the blade adapter and check the key inside hub of blade adapter. The key must be in good condition to work properly. Replace adapter if damaged.

TO REPLACE BLADE

1. Position the blade adapter on the engine crankshaft. Be sure key in adapter and crankshaft keyway are aligned.
2. Position blade on the blade adapter aligning the two (2) holes in the blade with the raised lugs on the adapter.
3. Be sure the trailing edge of blade (opposite sharp edge) is up toward the engine.
4. Install the blade bolt with the lock washer and hardened washer into blade adapter and crankshaft.
5. Use block of wood between blade and lawn mower housing and tighten the blade bolt, turning clockwise.
 - The recommended tightening torque is 35-40 ft. lbs. / 47-54 N-m.

IMPORTANT: Blade bolt is heat treated. If bolt needs replacing, replace only with approved bolt shown in the Repair Parts section of this manual.

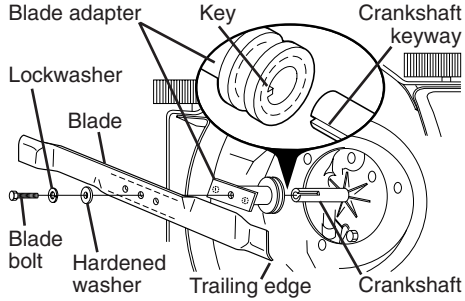

TO SHARPEN BLADE

NOTE: We do not recommend sharpening blade - but if you do, be sure the blade is balanced.

Care should be taken to keep the blade balanced. An unbalanced blade will cause eventual damage to lawn mower or engine.

- The blade can be sharpened with a file or on a grinding wheel. Do not attempt to sharpen while on the mower.
- To check blade balance, drive a nail into a beam or wall. Leave about one inch of the straight nail exposed. Place center hole of blade over the head of the nail. If blade is balanced, it should remain in a horizontal position. If either end of the blade moves downward, sharpen the heavy end until the blade is balanced.

CRAFTSMAN ROTARY LAWN MOWER -- MODEL NUMBER 944.367642

KEY NO.	PART NO.	DESCRIPTION	KEY NO.	PART NO.	DESCRIPTION	KEY NO.	PART NO.	DESCRIPTION	KEY NO.	PART NO.	DESCRIPTION
1	194200X479	Upper Handle	25	150406	Screw, Hex Head, Threaded,	48	851074	Hardened Washer	57	850733X004	Upstop Bracket
2	175245X479	Lower Handle	26	409148	Rolled 3/8-16 x 1-1/8	49	850263	Helical Washer	58	750634	Screw
3	194199X428	Control Bar	27	407754X460	Hex Flange Nut	50	851084	Screw, Machine, Hex Head, Grade 8 3/8-24 x 1-3/8	59	175071	Discharge Deflector
4	17411308	Screw	28	401638	Wheel & Tire Assembly	51	189686	Key Start Switch (Includes Key)	60	175735	Hinge Bracket
5	191574	Handle Bolt	29	411190	Shoulder Bolt 5/16-18 x .33	52	189589	Battery	61	193000	Spring, Torsion
6	189713X428	Handle Knob	30	401178X004	Trimplate	53	186159	Screw	62	175650	Hinge Rod
7	51793	Hairpin Cotter	31	701037	Axle Arm Assembly, Rear, RH	54	186237	Battery Box	63	73800400	Nut, Hex
8	66426	Wire Tie	32	401623X004	Selector Knob	55	180331	Key	64	175066	Mulcher Door
9	401812X428	Rear Door Assembly	33	198541	Selector Spring	56	191252	Trimplate/Battery Assembly	67	190097	Charger
10	128415	Pop Rivet	34	401630	Nut, Hex 3/8-16	57	850733X004	Upstop Bracket	96	197991	Clip, Cable
11	406573	Support Bracket, LH	35	141841	Washer, Curved, Cylindrical	58	750634	Screw	--	404764	Warning Decal (not shown)
12	406574	Support Bracket, RH	36	184193	Bolt	59	175071	Discharge Deflector	--	415051	Owner's Manual, English
13	17060410	Screw 1/4-20 x 5/8	37	401629	Spacer	60	175735	Hinge Bracket	--	415052	Owner's Manual, French
14	175082X479	Handle Bracket Assembly, LH	38	188839X004	Mounting Bracket,	61	193000	Spring, Torsion			
15	175081X479	Handle Bracket Assembly, RH	39	188839X004	Mounting Bracket,	62	175650	Hinge Rod			
16	405417	Spring, Rear Door, LH	40	188839X004	Mounting Bracket,	63	73800400	Nut, Hex			
17	405418	Spring, Rear Door, RH	41	192325	Debris Shield	64	175066	Mulcher Door			
18	132004	Keys Locknut 1/4-20	42	175551	Screw, Debris Shield	67	190097	Charger			
19	194788	Rope Guide	43	405845	Debris Shield	96	197991	Clip, Cable			
20	189005	Rear Skirt	44	413115	Kit, Mower Housing (Includes Key Numbers 10, 11, 12, 45)	--	404764	Warning Decal (not shown)			
21	88652	Hinge Screw 1/4-20 x 1-1/4	45	404763	Danger Decal	--	415051	Owner's Manual, English			
24	---	Engine, Briggs & Stratton, Model Number 126T05-0880-B2 (See Breakdown)	46	189179	Blade Adapter / Pulley						
			47	406706	Blade, 21"						

NOTE: All component dimensions given in U.S. inches. 1 inch = 25.4 mm.

IMPORTANT: Use only Original Equipment Manufacturer (O.E.M.) replacement parts. Failure to do so could be hazardous, damage your lawn mower and void your warranty.

REPAIR PARTS

CRAFTSMAN ROTARY LAWN MOWER -- MODEL NUMBER 944.367642

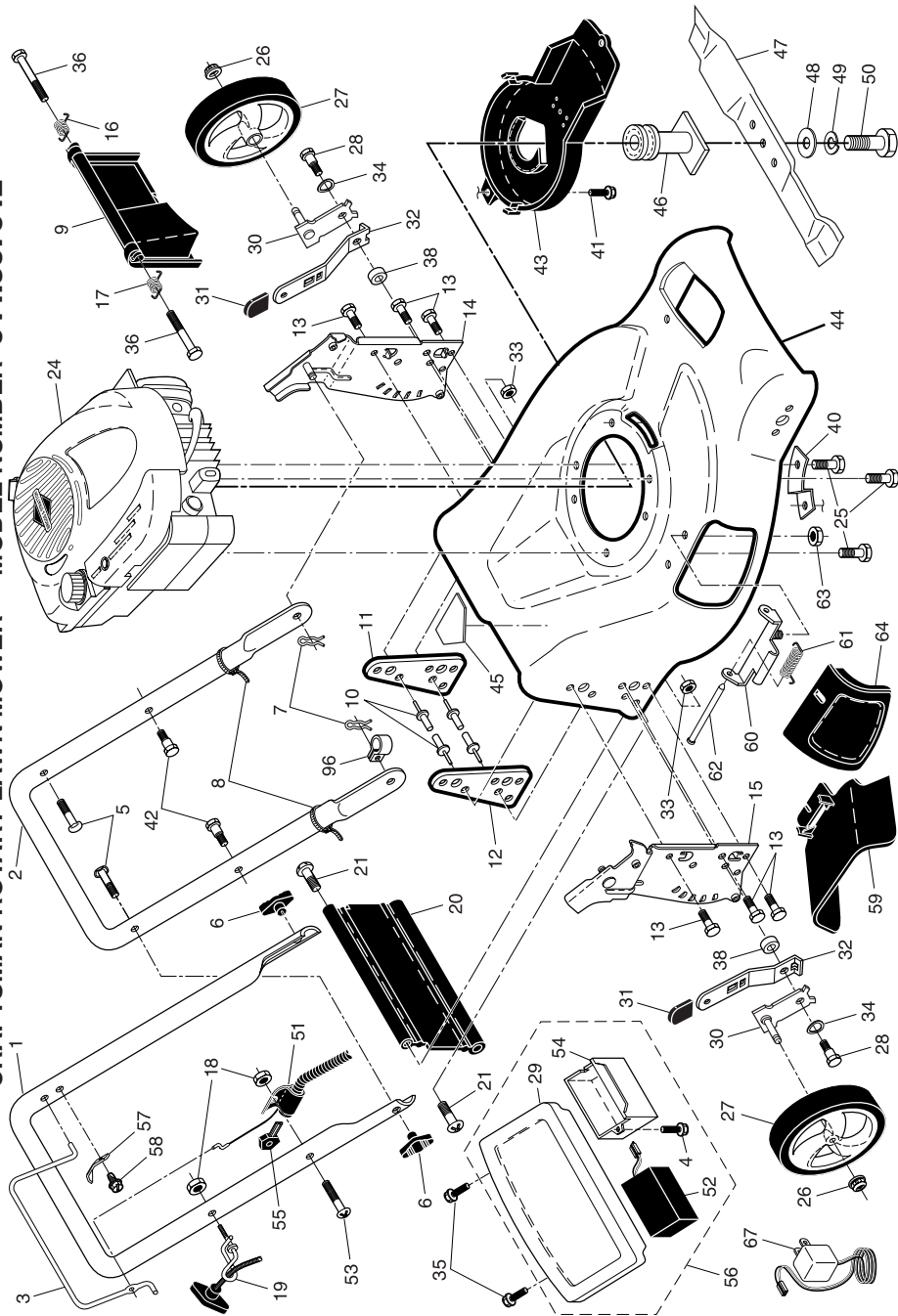

GRASS CATCHER

- The grass catcher may be hosed with water, but must be dry when used.
- Check your grass catcher often for damage or deterioration. Through normal use it will wear. If catcher needs replacing, replace only with approved replacement catcher shown in the Repair Parts section of this manual. Give the lawn mower model number when ordering.

GEAR CASE

- To keep your drive system working properly, the gear case and area around the drive should be kept clean and free of trash build-up. Clean under the drive cover twice a season.
- The gear case is filled with lubricant to the proper level at the factory. The only time the lubricant needs attention is if service has been performed on the gear case.
- If lubricant is required, use only Texaco Starplex Premium 1 Grease, Part No. 750369. Do not substitute.

ENGINE

LUBRICATION

Use only high quality detergent oil rated with API service classification SG-SL. Select the oil's SAE viscosity grade according to your expected operating temperature.

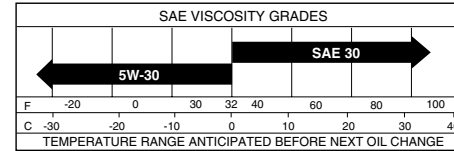

NOTE: Although multi-viscosity oils (5W30, 10W30 etc.) improve starting in cold weather, these multi-viscosity oils will result in increased oil consumption when used above 32°F. Check your engine oil level more frequently to avoid possible engine damage from running low on oil. Change the oil after every 25 hours of operation or at least once a year if the lawn mower is not used for 25 hours in one year. Check the crankcase oil level before starting the engine and after each five (5) hours of continuous use. Tighten oil plug securely each time you check the oil level.

TO CHANGE ENGINE OIL

NOTE: Before tipping lawn mower to drain oil, empty fuel tank by running engine until fuel tank is empty.

1. Disconnect spark plug wire from spark plug and place wire where it cannot come in contact with plug.

2. Remove engine oil cap; lay aside on a clean surface.
3. Tip lawn mower on its side as shown and drain oil into a suitable container. Rock lawn mower back and forth to remove any oil trapped inside of engine.

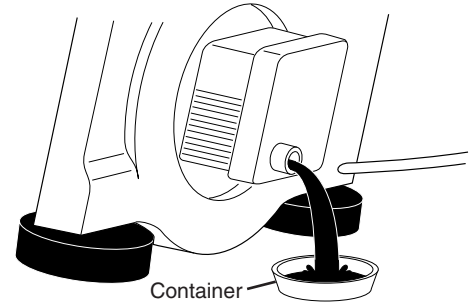

4. Wipe off any spilled oil from lawn mower or side of engine.
5. Slowly pour oil down the oil fill spout, stopping every few ounces to check the oil level with the dipstick.
6. Stop adding oil when you reach the FULL mark on the dipstick. Wait a minute to allow oil to settle.
7. Continue adding small amounts of oil, rechecking the dipstick until oil level settles at FULL. DO NOT overfill, or engine will smoke heavily from the muffler on startup.
8. Always be sure to retighten oil dipstick before starting engine.
9. Reconnect spark plug wire to spark plug.

AIR FILTER

Your engine will not run properly and may be damaged by using a dirty air filter. Replace the air filter cartridge every 100 hours of operation or every season, whichever occurs first. Service air cleaner more often under dusty conditions.

TO CLEAN AIR FILTER

1. Loosen screw and tilt cover to remove.
2. Carefully remove cartridge.
3. Clean by gently tapping on a flat surface. If very dirty, replace cartridge.

CAUTION: Petroleum solvents, such as kerosene, are not to be used to clean cartridge. They may cause deterioration of the cartridge. Do not oil cartridge. Do not use pressurized air to clean or dry cartridge.

4. Install cartridge, then replace cover making sure the tabs are aligned with the slots in the back plate. Fasten screw securely.

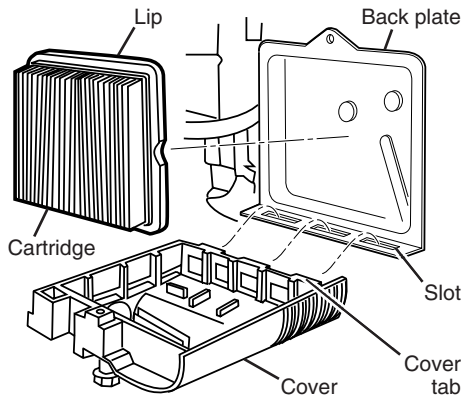

MUFFLER

Inspect and replace corroded muffler as it could create a fire hazard and/or damage.

SPARK PLUG

Replace spark plug at the beginning of each mowing season or after every 100 hours of operation, whichever occurs first. Spark plug type and gap setting are shown in the "PRODUCT SPECIFICATIONS" section of this manual.

CLEANING

IMPORTANT: For best performance, keep mower housing free of built-up grass and trash. Clean the underside of your mower after each use.

CAUTION: Disconnect spark plug wire from spark plug and place wire where it cannot come in contact with plug.

- Clean the underside of your lawn mower by scraping to remove build-up of grass and trash.
- Clean engine often to keep trash from accumulating. A clogged engine runs hotter and shortens engine life.
- Keep finished surfaces and wheels free of all gasoline, oil, etc.
- We do not recommend using a garden hose to clean lawn mower unless the electrical system, muffler, air filter and carburetor are covered to keep water out. Water in engine can result in shortened engine life.

CLEAN UNDER DRIVE COVER

Clean under drive cover at least twice a season. Scrape underside of cover with putty knife or similar tool to remove any build-up of trash or grass on underside of drive cover.

SERVICE NOTES

SERVICE AND ADJUSTMENTS

WARNING: To avoid serious injury, before performing any service or adjustments:

1. Release control bar and stop engine.
2. Make sure the blade and all moving parts have completely stopped.
3. Disconnect spark plug wire from spark plug and place wire where it cannot come in contact with plug.

LAWN MOWER

TO ADJUST CUTTING HEIGHT

See "TO ADJUST CUTTING HEIGHT" in the Operation section of this manual.

REAR DEFLECTOR

The rear deflector, attached between the rear wheels of your mower, is provided to minimize the possibility that objects will be thrown out of the rear of the mower into the operator mowing position. If the deflector becomes damaged, it should be replaced.

TO REMOVE DRIVE BELT

1. Remove drive cover and belt keeper.
2. Remove belt from gearcase pulley.
3. Turn lawn mower on its side with air filter and carburetor down.
4. Remove blade, engine pulley and debris shield.
5. Remove engine pulley and belt from debris shield.

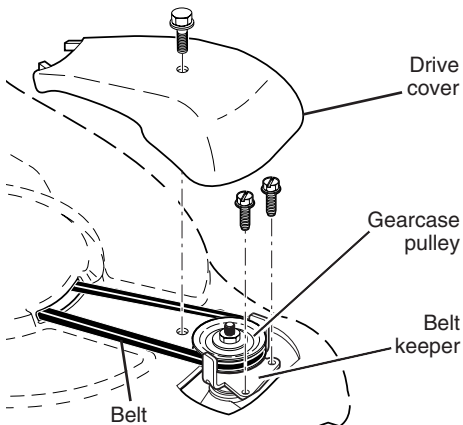

TROUBLESHOOTING - See appropriate section in manual unless directed to a Sears Service Centre.

PROBLEM	CAUSE	CORRECTION
Does not start (continued)	9. Control bar defective. 10. Fuel valve lever (if so equipped) in OFF position. 11. Weak battery (if equipped). 12. Disconnected battery connector (if equipped).	9. Replace control bar. 10. Turn fuel valve lever to the ON position. 11. Charge battery. 12. Connect battery to engine.
Loss of power	1. Rear of lawn mower housing or cutting blade dragging in heavy grass. 2. Cutting too much grass. 3. Dirty air filter. 4. Buildup of grass, leaves, and trash under mower. 5. Too much oil in engine. 6. Walking speed too fast.	1. Raise cutting height. 2. Raise cutting height. 3. Clean/replace air filter. 4. Clean underside of mower housing. 5. Check oil level. 6. Cut at slower walking speed.
Poor cut – uneven	1. Worn, bent or loose blade. 2. Wheel heights uneven. 3. Buildup of grass, leaves and trash under mower.	1. Replace blade. Tighten blade bolt. 2. Set all wheels at same height. 3. Clean underside of mower housing.
Excessive vibration	1. Worn, bent or loose blade. 2. Bent engine crankshaft.	1. Replace blade. Tighten blade bolt. 2. Contact a Sears or other qualified service centre.
Starter rope hard to pull	1. Engine flywheel brake is on when control bar is released. 2. Bent engine crankshaft. 3. Blade adapter broken. 4. Blade dragging in grass.	1. Depress control bar to upper handle before pulling starter rope. 2. Contact a Sears or other qualified service centre. 3. Replace blade adapter. 4. Move lawn mower to cut grass or to hard surface.
Grass catcher not filling (If so equipped)	1. Cutting height too low. 2. Lift on blade worn off. 3. Catcher not venting air.	1. Raise cutting height. 2. Replace blade. 3. Clean grass catcher.
Hard to push	1. Grass is too high or wheel height is too low. 2. Rear of lawn mower housing or cutting blade dragging in grass. 3. Grass catcher too full. 4. Handle height position not right for you.	1. Raise cutting height. 2. Raise rear of lawn mower housing one (1) setting higher. 3. Empty grass catcher. 4. Adjust handle height to suit.
Loss of drive or slowing of drive speed	1. Belt wear. 2. Belt off of pulley. 3. Drive cable worn or broken.	1. Check/replace drive belt. 2. Check/reinstall drive belt. 3. Replace drive cable.

TO REPLACE DRIVE BELT

1. Place new drive belt in engine pulley and belt retainer of debris shield.
2. Route the other end of the new drive belt through hole in housing.
3. Reinstall debris shield.
4. Return mower to upright position.
5. Install new belt on gearcase pulley.
6. Reinstall belt keeper and drive cover.
- NOTE:** Always use factory approved belt to assure proper fit and long life.
7. Turn lawn mower on its side with air filter and carburetor down.
8. Reinstall blade.

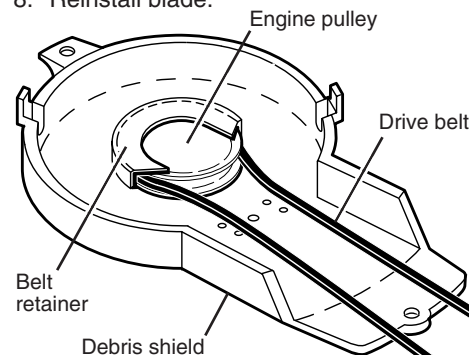

TO ADJUST HANDLE

The handle can be mounted in a high or low position. The mounting holes in the bottom of lower handle are off center for raising or lowering the handle.

1. Remove upper handle and wire tie(s) securing cable(s) to lower handle.
2. Remove trimplate from lower handle.
3. Remove hairpin cotter from lower handle bracket mounting pin.
4. Squeeze lower handle in to remove it from mounting pins.
5. Turn lower handle over to raise or lower handle.
6. Squeeze lower handle in and position holes onto mounting pins on handle bracket.
7. Reassemble trimplate to lower handle.
8. Reassemble upper handle and all parts removed from lower handle.

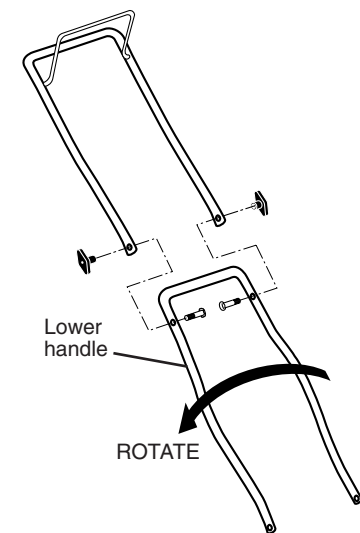
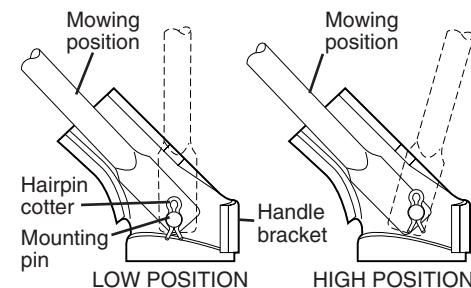
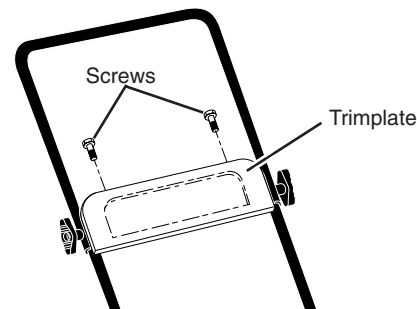

ENGINE ENGINE SPEED

Your engine speed has been factory set. Do not attempt to increase engine speed or it may result in personal injury. If you believe that the engine is running too fast or too slow, take your lawn mower to a Sears or other qualified service centre for repair and adjustment.

CARBURETOR

Your carburetor is not adjustable. If your engine does not operate properly due to suspected carburetor problems, take your lawn mower to a Sears or other qualified service centre for repair or adjustment. **IMPORTANT:** Never tamper with the engine governor, which is factory set for proper engine speed. Overspeeding the engine above the factory high speed setting can be dangerous. If you think the engine-governed high speed needs adjusting, contact a Sears or other qualified service centre, which has proper equipment and experience to make any necessary adjustments.

STORAGE

Immediately prepare your lawn mower for storage at the end of the season or if the unit will not be used for 30 days or more.

LAWN MOWER

When lawn mower is to be stored for a period of time, clean it thoroughly, remove all dirt, grease, leaves, etc. Store in a clean, dry area.

1. Clean entire lawn mower (See "CLEANING" in the Maintenance section of this manual).
2. Lubricate as shown in the Maintenance section of this manual.
3. Be sure that all nuts, bolts, screws, and pins are securely fastened. Inspect moving parts for damage, breakage and wear. Replace if necessary.
4. Touch up all rusted or chipped paint surfaces; sand lightly before painting.

HANDLE

You can fold your lawn mower handle for storage.

1. Squeeze the bottom ends of the lower handle toward each other until the lower handle clears the handle bracket, then move handle forward.
2. Loosen upper handle mounting bolts enough to allow upper handle to be folded back.

IMPORTANT: When folding the handle for storage or transportation, be sure to fold the handle as shown or you may damage the control cables.

- When setting up your handle from the storage position, the lower handle will automatically lock into the mowing position.

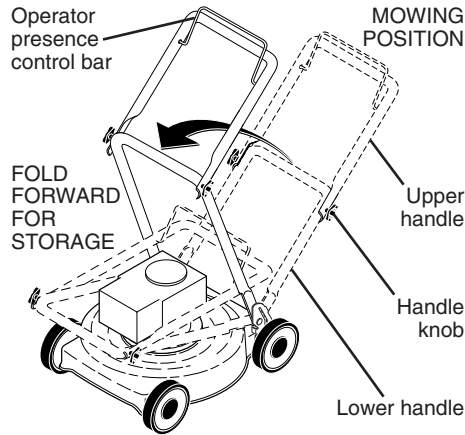
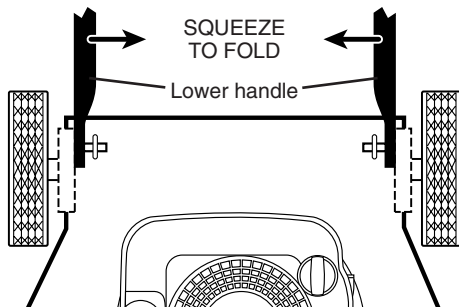

ENGINE FUEL SYSTEM

IMPORTANT: It is important to prevent gum deposits from forming in essential fuel system parts such as carburetor, fuel filter, fuel hose or tank during storage. Alcohol blended fuels (called gasohol or using ethanol or methanol) can attract moisture which leads to separation and formation of acids during storage. Acidic gas can damage the fuel system of an engine while in storage.

- Empty the fuel tank by starting the engine and letting it run until the fuel lines and carburetor are empty.
- Never use engine or carburetor cleaner products in the fuel tank or permanent damage may occur.
- Use fresh fuel next season.

NOTE: Fuel stabilizer is an acceptable alternative in minimizing the formation of fuel gum deposits during storage. Add stabilizer to gasoline in fuel tank or storage container. Always follow the mix ratio found on stabilizer container. Run engine at least 10 minutes after adding stabilizer to allow the stabilizer to reach the carburetor. Do not drain the gas tank and carburetor if using fuel stabilizer.

NOTE: FRESH START™ fuel cap and cartridge system automatically drips concentrated fuel preserver into your fuel tank and is an acceptable alternative to adding fuel stabilizer.

ENGINE OIL

Drain oil (with engine warm) and replace with clean engine oil. (See "ENGINE" in the Maintenance section of this manual).

CYLINDER

1. Remove spark plug.
2. Pour 30 ml of oil through spark plug hole into cylinder.
3. Pull starter handle slowly a few times to distribute oil.
4. Replace with new spark plug.

BATTERY

Disconnect the battery from the engine connector and charge battery 48 hours.

OTHER

- Do not store gasoline from one season to another.
- Replace your gasoline can if your can starts to rust. Rust and/or dirt in your gasoline will cause problems.
- If possible, store your unit indoors and cover it to protect it from dust and dirt.
- Cover your unit with a suitable protective cover that does not retain moisture. Do not use plastic. Plastic cannot breathe, which allows condensation to form and will cause your unit to rust.

IMPORTANT: Never cover mower while engine and exhaust areas are still warm.

CAUTION: Never store the lawn mower with gasoline in the tank inside a building where fumes may reach an open flame or spark. Allow the engine to cool before storing in any enclosure.

TROUBLESHOOTING - See appropriate section in manual unless directed to a Sears Service Centre.

PROBLEM	CAUSE	CORRECTION
Does not start	1. Dirty air filter.	1. Clean/replace air filter.
	2. Out of fuel.	2. Fill fuel tank.
	3. Stale fuel.	3. Empty fuel tank and refill tank with fresh, clean gasoline.
	4. Water in fuel.	4. Empty fuel tank and refill tank with fresh, clean gasoline.
	5. Spark plug wire is disconnected.	5. Connect wire to plug.
	6. Bad spark plug.	6. Replace spark plug.
	7. Loose blade or broken blade adapter.	7. Tighten blade bolt or replace blade adapter.
	8. Control bar in released position.	8. Depress control bar to handle.