

Get it fixed, at your home or ours!

Just Call:

**1-800-4-MY-HOME®**

(1-800-469-4663)

24 hours a day, 7 days a week

For the repair of major brand appliances **in your own home...**  
no matter who made it, no matter who sold it!

For your nearest **Sears Parts and Service** location,  
to bring in products like vacuums, lawn equipment and electronics.

For **Sears Parts & Service**, to order the replacement parts,  
accessories and owner's manuals that you need to do-it-yourself.

[www.sears.ca](http://www.sears.ca)

To purchase or inquire about a Sears Maintenance Agreement, call:

**1-800-361-6665**

9 a.m. – 11 p.m. Mon. – Fri., EST, 9 a.m. – 4 p.m. Sat.

Pour service en français:

**1-800-LE-FOYER<sup>MC</sup>**

(1-800-533-6937)

[www.sears.ca](http://www.sears.ca)



® / <sup>TM</sup> Trademarks of Sears, Roebuck and Co. used under license by Sears Canada

<sup>MD</sup> Marque déposée / <sup>MC</sup> Marque de commerce de Sears, Roebuck and Co. utilisée en vertu d'une licence de Sears Canada

Owner's Manual

**H Husqvarna**

**ROTARY LAWN MOWER**

700 Series Briggs & Stratton Engine

18" Multi-Cut

Model No.

**944.368940**



**CAUTION:**

Read and follow all  
Safety Rules and Instructions  
before operating this equipment

Sears Canada, Inc., Toronto, Ontario M5B 2B8

## TABLE OF CONTENTS

Safety Rules .....	2-3	Maintenance.....	11-14
Warranty .....	4	Service and Adjustments.....	15
Product Specifications .....	5	Storage.....	16-17
Assembly/Pre-Operation .....	6	Troubleshooting.....	18-19
Operation.....	7-10	Repair Parts.....	20-27
Maintenance Schedule.....	11	Sears Service .....	Back Cover

## SAFETY RULES

**IMPORTANT:** This cutting machine is capable of amputating hands and feet and throwing objects. Failure to observe the following safety instructions could result in serious injury or death.

**⚠** Look for this symbol to point out important safety precautions. It means **CAUTION!!! BECOME ALERT!!! YOUR SAFETY IS INVOLVED.**

**⚠ WARNING:** In order to prevent accidental starting when setting up, transporting, adjusting or making repairs, always disconnect spark plug wire and place wire where it cannot come in contact with plug.

**⚠ CAUTION:** Muffler and other engine parts become extremely hot during operation and remain hot after engine has stopped. To avoid severe burns on contact, stay away from these areas.



### I. GENERAL OPERATION

- Read, understand, and follow all instructions on the machine and in the manual(s) before starting. Be thoroughly familiar with the controls and the proper use of the machine before starting.
- Do not put hands or feet near or under rotating parts. Keep clear of the discharge opening at all times.
- Only allow responsible individuals, who are familiar with the instructions, to operate the machine.
- Clear the area of objects such as rocks, toys, wire, bones, sticks, etc., which could be picked up and thrown by blade.
- Be sure the area is clear of other people before mowing. Stop machine if anyone enters the area.
- Do not operate the mower when bare-foot or wearing open sandals. Always wear substantial foot wear.
- Do not pull mower backwards unless absolutely necessary. Always look down and behind before and while moving backwards.

- Never direct discharged material toward anyone. Avoid discharging material against a wall or obstruction. Material may ricochet back toward the operator. Stop the blade when crossing gravel surfaces.
- Do not operate the mower without proper guards, plates, grass catcher or other safety protective devices in place.
- See manufacturer's instructions for proper operation and installation of accessories. Only use accessories approved by the manufacturer.
- Stop the blade(s) when crossing gravel drives, walks, or roads.
- Stop the engine (motor) whenever you leave the equipment, before cleaning the mower or unclogging the chute.
- Shut the engine (motor) off and wait until the blade comes to complete stop before removing grass catcher.
- Mow only in daylight or good artificial light.
- Do not operate the machine while under the influence of alcohol or drugs.
- Never operate machine in wet grass. Always be sure of your footing: keep a firm hold on the handle; walk, never run.
- Disengage the self-propelled mechanism or drive clutch on mowers so equipped before starting the engine.
- If the equipment should start to vibrate abnormally, stop the engine (motor) and check immediately for the cause. Vibration is generally a warning of trouble.
- Always wear safety goggles or safety glasses with side shields when operating mower.

### II. SLOPE OPERATION

Slopes are a major factor related to slip & fall accidents which can result in severe injury. All slopes require extra caution. If you feel uneasy on a slope, do not mow it.

KEY NO.	PART NO.	DESCRIPTION	KEY NO.	PART NO.	DESCRIPTION
425	793460	Screw (Air Cleaner Cover)	923	793490	Brake
445	792038	Filter-Air Cleaner Cartridge	955	793465	Plug-Carburetor
505	793515	Nut (Governor Control Lever)	957	692046	Cap-Fuel Tank
523	793475	Dipstick	968	793428	Cover-Air Cleaner
524	793476	Seal-Dipstick Tube	972	793472	Tank-Fuel
525	793477	Tube-Dipstick	975	793464	Bowl-Float
535	698369	Filter-Air Cleaner Foam	1022*>	793437	Gasket-Rocker Cover
562	793514	Screw (Governor Control Lever)	1023	793436	Cover-Rocker
592	793481	Nut (Rewind Starter)	1036	- - -	Label-Emissions (Available from a Briggs & Stratton Authorized Dealer)
601	791850	Clamp-Hose	1059	793471	Kit - Screw / Washer (Fuel Tank)
608	793470	Starter-Rewind	1095	793624	Gasket Set-Valve
613	793495	Screw (Muffler)	1263	697124	Reed-Breather
615	690340	Retainer-Governor Shaft	1264	793453	Screw (Breather Reed)
616	793448	Crank-Governor	1329	100602-0025	Replacement Engine (Replacement engine listed is not available in the State of California. Repair with individual parts.)
621	692310	Switch-Stop	1375	793442	Cover-Breather/Reed
623	793628	Seal-O Ring (Carburetor Spacer)	1376	699851	Screw (Breather/Reed Cover)
635	66538S	Boot-Spark Plug	1395	793459	Screw (Air Cleaner Base to Carburetor)
662	793478	Stud (Rewind Starter)(Short)	- -	398067	Spark Arrester (available accessory)
662A	793479	Stud (Rewind Starter)(Long)	* Included in Engine Gasket Set, Key No. 358		
670	793485	Spacer-Fuel Tank	> Included in Valve Gasket Set, Key No. 1095		
689	691855	Spring-Friction	<b>NOTE:</b> All component dimensions given in U.S. inches. 1 inch = 25.4 mm		
718	690959	Pin-Locating (Cylinder)			
741	793446	Gear-Timing			
745	793491	Screw (Brake)			
787	793513	Arm-Lever			
793	793511	Screw/Nut Set (Lever Arm)			
847	793474	Dipstick/Tube Assembly			
851	493880S	Terminal-Spark Plug			
868	>* 793507	Seal-Valve			
875	793492	Base-Air Cleaner			
883	>* 793497	Gasket-Exhaust			
914	794451	Screw (Rocker Cover)			
922	692135	Spring-Brake			

KEY NO.	PART NO.	DESCRIPTION	KEY NO.	PART NO.	DESCRIPTION
1	793508	Cylinder Assembly	75	691736	Washer (Flywheel)
3	* 299819S	Seal-Oil (PTO Side)	78	793480	Screw (Flywheel Guard)
4	793509	Sump-Engine	81	691740	Lock-Muffler Screw
5	793502	Head-Cylinder	104	698536	Pin-Float Hinge
7	*> 793455	Gasket-Cylinder Head	105	698537	Valve-Float Needle
9	* 793439	Gasket-Breather	117	793694	Jet-Main (Standard)
11	793447	Tube-Breather	118	793695	Jet-Main (High Altitude)
12	* 793445	Gasket-Crankcase	121	793622	Kit-Carburetor Overhaul
13	793451	Screw (Cylinder Head)	125	793493	Carburetor
15	691680	Plug-Oil Drain	133	698539	Float-Carburetor
16	793426	Crankshaft	137	698538	Gasket-Float Bowl
20	* 399781S	Seal-Oil (Magneto Side)	163	* 691894	Gasket-Air Cleaner
22	793450	Screw (Engine Sump)	177	691031	Seal-O Ring (Dipstick)
23	793489	Flywheel	187	791766	Line-Fuel (Cut to Required Length)
24	222698S	Key-Flywheel	202	793433	Link-Mechanical Governor
25	793519	Piston Assembly (Standard)	209	793427	Spring-Governor (Yellow)
25	793518	Piston Assembly (.020" Oversize)	216	793494	Link-Choke
26	793435	Ring Set (Standard)	222	793487	Bracket-Control
26	793517	Ring Set (.020" Oversize)	227	793516	Lever-Governor Control
27	691588	Lock-Piston Pin	238	793535	Cap-Valve
28	298909	Pin-Piston	276	793627	Washer-Sealing
29	793510	Rod-Connecting	291	793498	Thermostat
32	691664	Screw (Connecting Rod)(Short)	300	793496	Muffler
32A	695759	Screw (Connecting Rod)(Long)	304	793486	Housing-Blower
33	793505	Valve-Exhaust	332	690662	Nut (Flywheel)
34	793504	Valve-Intake	333	793449	Armature-Magneto
35	793506	Spring-Valve (Intake)	334	793454	Screw (Magneto Armature)
36	793506	Spring-Valve (Exhaust)	337	692720	Plug-Spark
37	793473	Guard-Flywheel	356	692390	Wire-Stop
48	795158	Short Block	358	793623	Gasket Set-Engine
51	*> 692555	Gasket-Intake	363	19069	Flywheel Puller
58	697316	Rope-Starter	365	793458	Screw (Carburetor)
60	281434S	Grip-Starter Rope	371	794574	Gear-Cam
			383	19576S	Wrench-Spark Plug
			404	690272	Washer (Governor Crank)

**DO:**

- Mow across the face of slopes: never up and down. Exercise extreme caution when changing direction on slopes.
- Remove obstacles such as rocks, tree limbs, etc.
- Watch for holes, ruts, or bumps. Tall grass can hide obstacles.

**DO NOT:**

- Do not trim near drop-offs, ditches or embankments. The operator could lose footing or balance.
- Do not trim excessively steep slopes.
- Do not mow on wet grass. Reduced footing could cause slipping.

**III. CHILDREN**

Tragic accidents can occur if the operator is not alert to the presence of children. Children are often attracted to the machine and the mowing activity. *Never* assume that children will remain where you last saw them.

- Keep children out of the trimming area and under the watchful care of another responsible adult.
- Be alert and turn machine off if children enter the area.
- Before and while walking backwards, look behind and *down* for small children.
- Never allow children to operate the machine.
- Use extra care when approaching blind corners, shrubs, trees, or other objects that may obscure vision.

**IV. SAFE HANDLING OF GASOLINE**

Use extreme care in handling gasoline. Gasoline is extremely flammable and the vapors are explosive.

- Extinguish all cigarettes, cigars, pipes and other sources of ignition.
- Use only an approved container.
- Never remove gas cap or add fuel with the engine running. Allow engine to cool before refueling.
- Never refuel the machine indoors.
- Never store the machine or fuel container where there is an open flame, spark or pilot light such as a water heater or on other appliances.

- Never fill containers inside a vehicle, on a truck or trailer bed with a plastic liner. Always place containers on the ground away from your vehicle before filling.
- Remove gas-powered equipment from the truck or trailer and refuel it on the ground. If this is not possible, then refuel such equipment with a portable container, rather than from a gasoline dispenser nozzle.
- Keep the nozzle in contact with the rim of the fuel tank or container opening at all times until fueling is complete. Do not use a nozzle lock-open device.
- If fuel is spilled on clothing, change clothing immediately.
- Never overfill fuel tank. Replace gas cap and tighten securely.

**V. GENERAL SERVICE**

- Never run machine inside a closed area.
- Never make adjustments or repairs with the engine (motor) running. Disconnect the spark plug wire, and keep the wire away from the plug to prevent accidental starting.
- Keep nuts and bolts, especially blade attachment bolts, tight and keep equipment in good condition.
- Never tamper with safety devices. Check their proper operation regularly.
- Keep machine free of grass, leaves, or other debris build-up. Clean oil or fuel spillage. Allow machine to cool before storing.
- Stop and inspect the equipment if you strike an object. Repair, if necessary, before restarting.
- Never attempt to make wheel height adjustments while the engine is running.
- Grass catcher components are subject to wear, damage, and deterioration, which could expose moving parts or allow objects to be thrown. Frequently check components and replace with manufacturer's recommended parts, when necessary.
- Mower blades are sharp and can cut. Wrap the blade(s) or wear gloves, and use extra caution when servicing them.
- Do not change the engine governor setting or overspeed the engine.
- Maintain or replace safety and instruction labels, as necessary.

**▲WARNING:** This lawn mower is equipped with an internal combustion engine and should not be used on or near any unimproved forest-covered, brush-covered or grass-covered land unless the engine's exhaust system is equipped with a spark arrester meeting applicable local or state laws (if any). If a spark arrester is used, it should be maintained in effective working order by the operator. A spark arrester for the muffler is available through your nearest Husqvarna or other authorized Service Centre (See the REPAIR PARTS section of this manual).



# WARRANTY

## SECTION 1: LIMITED WARRANTY

Husqvarna Forest & Garden Company ("Husqvarna") warrants Husqvarna product to the original purchaser to be free from defects in material and workmanship from the date of purchase for the "Warranty Period" of the product as set forth below:

**2 YEAR NON-COMMERCIAL WARRANTY:** Automatic Mower, Riding lawn mowers, yard and garden tractors, walk behind mowers, tillers, chain saws, trimmers, brushcutters, clearing saws, snow blowers, handheld blowers, backpack blowers, hedge trimmers, electrical products and power-assist collection systems for noncommercial, nonprofessional, noninstitutional or nonincome producing use, except as herein stated.

Emission control system components necessary to comply with CARB-TIER-II and EPA regulations.

**Husqvarna Safety Apparel** carries a 90-day warranty from the date of the customer's original purchase for defects in material and workmanship. Normal wear, tear or abuse is not covered under warranty. Product must be returned to Charlotte with a warranty claim form. All care and maintenance instructions must be followed as stated by the manufacturer on the care label. The fit of the protective apparel/boot is not covered under warranty.

## SECTION 2: HUSQVARNA'S OBLIGATIONS UNDER THE WARRANTY

Husqvarna will repair or replace defective components without charge for parts or labor if a component fails because of a defect in material or workmanship during the warranty period.

## SECTION 3: ITEMS NOT COVERED BY THIS WARRANTY

The following items are not covered by this warranty:

- (1) Normal customer maintenance items which become worn through normal regular use, including, but not limited to, belts, blades, blade adapters, bulbs, filters, guide bars, lubricants, rewind springs, saw chain, spark plugs, starter ropes and tines;
- (2) Natural discoloration of material due to ultraviolet light;
- (3) Lawn and garden attachments are covered by a third party which gives a warranty, all claims for warranty should be sent to the manufacturer; and
- (4) Emission Control System components necessary to which are manufactured by third party engine manufacturer.

## SECTION 4: EXCEPTIONS AND LIMITATIONS

This warranty shall be inapplicable to defects resulting from the following:

- (1) Accident, abuse, misuse, negligence and neglect, including stale fuel, dirt, abrasives, moisture, rust, corrosion, or any adverse reaction due to incorrect storage or use habits;
- (2) Failure to operate or maintain the unit in accordance with the Owner's/Operator's manual or instruction sheet furnished by Husqvarna;
- (3) Alterations or modifications that change the intended use of the product or affects the product's performance, operation, safety, or durability, or causes the product to fail to comply with any applicable laws; or:

- (4) Additional damage to parts or components due to continued use occurring after any of the above.

REPAIR OR REPLACEMENT AS PROVIDED UNDER THIS WARRANTY IS THE EXCLUSIVE REMEDY OF THE PURCHASER. HUSQVARNA SHALL NOT BE LIABLE FOR ANY INCIDENTAL OR CONSEQUENTIAL DAMAGES FOR BREACH OF ANY EXPRESS OR IMPLIED WARRANTY ON THESE PRODUCTS EXCEPT TO THE EXTENT PROHIBITED BY APPLICABLE LAW. ANY IMPLIED WARRANTY OF MERCHANTABILITY OR FITNESS FOR A PARTICULAR PURPOSE ON THESE PRODUCTS IS LIMITED IN DURATION TO THE WARRANTY PERIOD AS DEFINED IN THE LIMITED WARRANTY STATEMENT. HUSQVARNA RESERVES THE RIGHT TO CHANGE OR IMPROVE THE DESIGN OF THE PRODUCT WITHOUT NOTICE, AND DOES NOT ASSUME OBLIGATION TO UPDATE PREVIOUSLY MANUFACTURED PRODUCTS.

Some states do not allow the exclusion of incidental or consequential damages, or limitations on how long an implied warranty lasts, so the above limitations or exclusions may not apply to you. This warranty gives you specific legal rights, and you may also have other rights which vary from state to state.

## SECTION 5: CUSTOMER RESPONSIBILITIES

The product must exhibit reasonable care, maintenance, operation, storage and general upkeep as written in the maintenance section of the Owner's/Operator's manual. Should an operational problem or failure occur, the product should not be used, but delivered as is to an authorized Husqvarna dealer for evaluation. Proof of purchase, as explained in section 6, rests solely with the customer.

## SECTION 6: PROCEDURE TO OBTAIN WARRANTY CONSIDERATION

It is the Owner's and Dealer's responsibility to make certain that the Warranty Registration Card is properly filled out and mailed to Husqvarna Forest & Garden Company. This card should be mailed within ten (10) days from the date of purchase in order to confirm the warranty and to facilitate post-sale service.

Proof of purchase must be presented to the authorized Husqvarna dealer in order to obtain warranty service. This proof must include date purchased, model number, serial number, and complete name and address of the selling dealer.

To obtain the benefit of this warranty, the product believed to be defective must be delivered to an authorized Husqvarna dealer in a timely manner, no later than thirty (30) days from date of the operational problem or failure. The product must be delivered at the owner's expense. Pick-up and delivery charges are not covered by this warranty. An authorized Husqvarna dealer can be normally located through the "Yellow Pages" of the local telephone directory or by calling 1-800-HUSKY62 for a dealer in your area.

HUSQVARNA  
7349 Statesville Road  
Charlotte, NC 28269  
531 83 81-23 2002

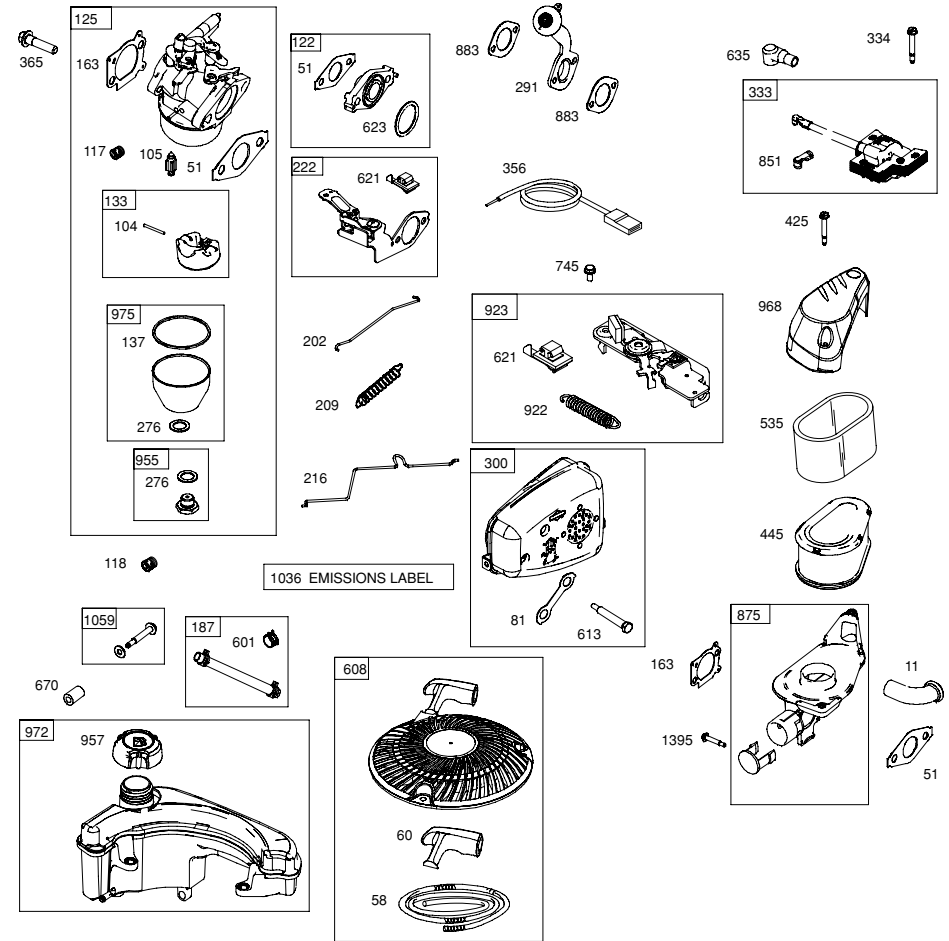

## Engine Power Rating Information

The gross power rating for individual gas engine models is labeled in accordance with SAE (Society of Automotive Engineers) code J11940 (Small Engine Power & Torque Rating Procedure), and rating performance has been obtained and corrected in accordance with SAE J1995 (Revision 2002-5). Actual gross engine power will be lower and is affected by, among other things, ambient operating conditions and engine-to-engine variability. Given both the wide array of products on which engines are placed and the variety of environmental issues applicable to operating the equipment, the gas engine will not develop the rated gross power when used in a given piece of power equipment (actual "on-site" or net horsepower). This difference is due to a variety of factors including, but not limited to, accessories (air cleaner, exhaust, charging, cooling, carburetor, fuel pump, etc.), application limitations, ambient operating conditions (temperature, humidity, altitude), and engine-to-engine variability. Due to manufacturing and capacity limitations, Briggs & Stratton may substitute an engine of higher rated power for this Series engine.

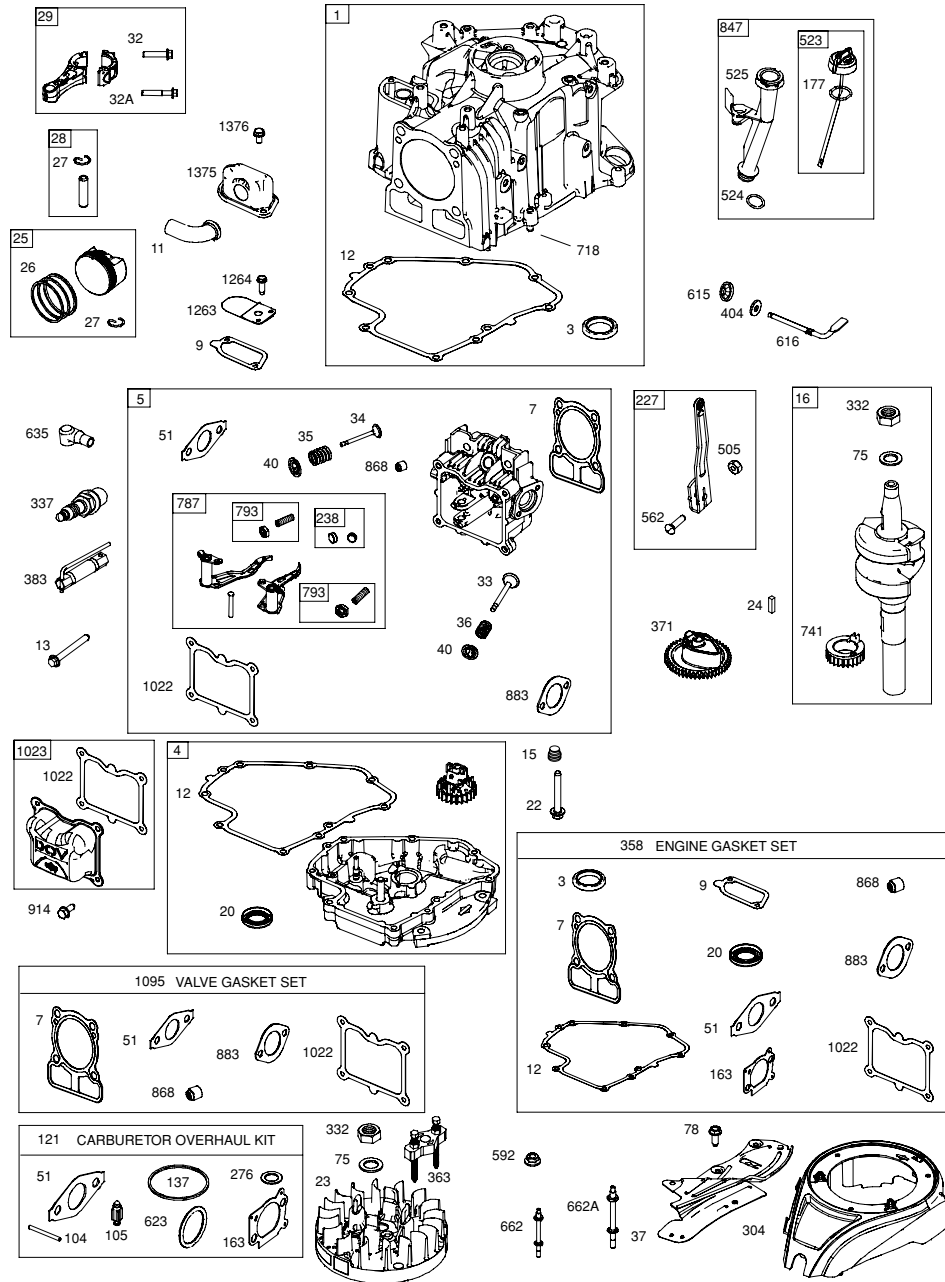

**PRODUCT SPECIFICATIONS**

Serial Number:	
Date of Purchase:	
Gasoline Capacity / Type:	1,5 Litres (Unleaded Regular)
Oil Capacity:	0,58 Litres
Oil Type (API SG–SL):	SAE 30 (above 0°C/32°F); SAE 5W-30 (below 0°C/32°F)
Spark Plug:	Champion RC12YC (Gap: 0,76 mm)
Blade Bolt Torque:	45–54 N-m (35–40 ft. lbs.).

• The model and serial numbers will be found on a decal on the rear of the lawn mower housing. Record both serial number and date of purchase in space provided above.

## ASSEMBLY / PRE-OPERATION

Read these instructions and this manual in its entirety before you attempt to assemble or operate your new lawn mower.

**IMPORTANT:** This lawn mower is shipped WITHOUT OIL OR GASOLINE in the engine. Your new lawn mower has been assembled at the factory with the exception of those parts left unassembled for shipping purposes. All parts such as nuts, washers, bolts, etc., necessary to complete the assembly have been placed in the parts bag. To ensure safe and proper operation of your lawn mower, all parts and hardware you assemble must be tightened securely. Use the correct tools as necessary to ensure proper tightness.

### TO REMOVE MOWER FROM CARTON

1. Remove loose parts included with mower.
2. Cut down two end corners of carton and lay end panel down flat.
3. Remove all packing materials except padding between upper and lower handle and padding holding operator presence control bar to upper handle.
4. Roll mower out of carton and check carton thoroughly for additional loose parts.

### HOW TO SET UP YOUR MOWER TO UNFOLD HANDLE

**IMPORTANT:** Unfold handle carefully so as not to pinch or damage control cables.

1. Raise lower handle section to operating position and align hole in handle with one of the height positioning holes in the handle bracket.
2. Insert handle bolt through handle and bracket and secure with knob.
3. Repeat for opposite side of handle.
4. Remove protective padding, raise upper handle section into place on lower handle and tighten both handle knobs.
5. Remove any packing material from around control bar.

Your lawn mower handle can be adjusted for your mowing comfort. Refer to "ADJUST HANDLE" in the Service and Adjustments section of this manual.

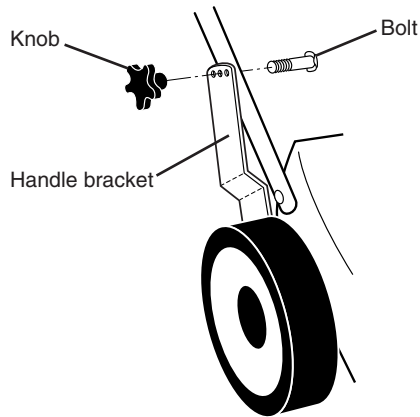
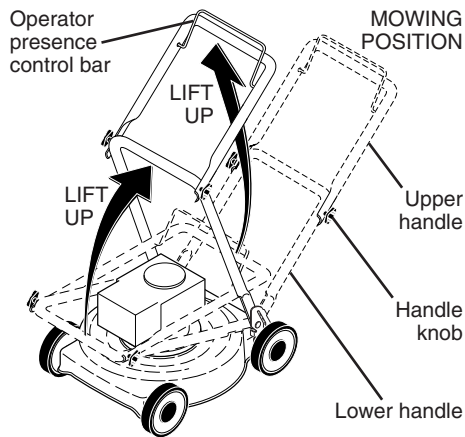

### TO ASSEMBLE GRASS CATCHER

1. Slide grass catcher bag over the frame. Make sure the beveled section is on the bottom.
  2. Slip vinyl bindings over frame.
- NOTE:** If vinyl bindings are too stiff, hold them in warm water for a few minutes. If bag gets wet, let it dry before using.

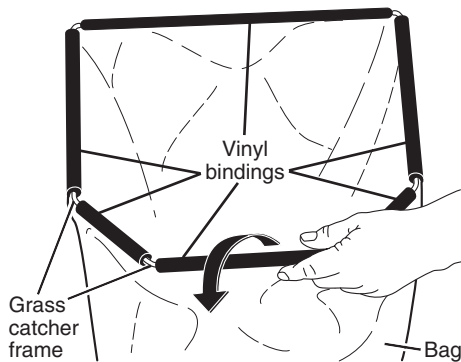

### TO INSTALL ATTACHMENTS

Your lawn mower was shipped ready to be used as a mulcher. To convert mower to bagging or discharging, see "TO CONVERT MOWER" in the Operation section of this manual.

## HUSQVARNA ROTARY LAWN MOWER -- MODEL NUMBER 944.368940

KEY PART NO. NO.	DESCRIPTION
27	401273X460 Wheel & Tire Assembly
28	88348 Washer, Flat
29	197480 O-Ring
30	199235X418 Bearing Assembly, Front Axle
31	407145X004 Axle Assembly, Front
32	400094 Fitting, Quick Release
33	407168X004 Axle Assembly, Rear
41	159736 Decal, Hot Muffler
42	402786 Decal, Warning
43	404763 Decal, Danger
58	72110407 Bolt, Carriage
61	850263 Washer, Lock, Helical Spring 3/8

KEY PART NO. NO.	DESCRIPTION
6	12000012 Ring, Retaining
7	199245 Bearing, Drive
12	163409 Screw, Hi-Lo Thread #12 x 5/8
18	409148 Nut, Hex
20	400100 Locknut, Hex 1/4-20
22	199246X004 Height Adjustment Lever, Rear
23	199269 Knob, Height Adjustment Lever
24	407059 Screw
25	407142 Height Adjustment Lever, Front
26	409616 Spring

**IMPORTANT:** Use only Original Equipment Manufacturer (O.E.M.) replacement parts. Failure to do so could be hazardous, damage your lawn mower and void your warranty.

**NOTE:** All component dimensions given in U.S. inches. 1 inch = 25.4 mm.

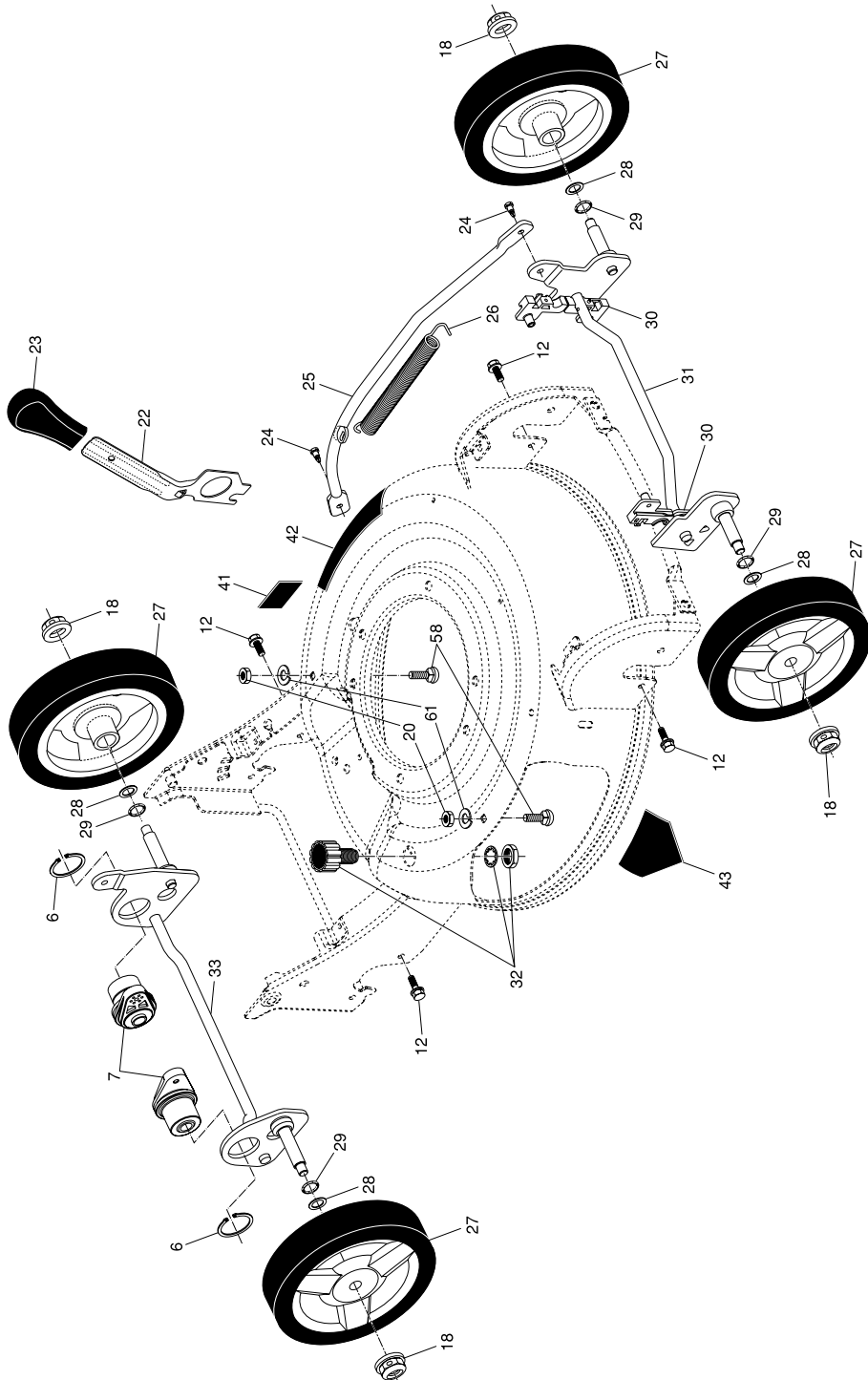

## OPERATION

### KNOW YOUR LAWN MOWER

READ THIS OWNER'S MANUAL AND ALL SAFETY RULES BEFORE OPERATING YOUR LAWN MOWER. Compare the illustrations with your lawn mower to familiarize yourself with the location of various controls and adjustments. Save this manual for future reference.

These symbols may appear on your lawn mower or in literature supplied with the product. Learn and understand their meaning.

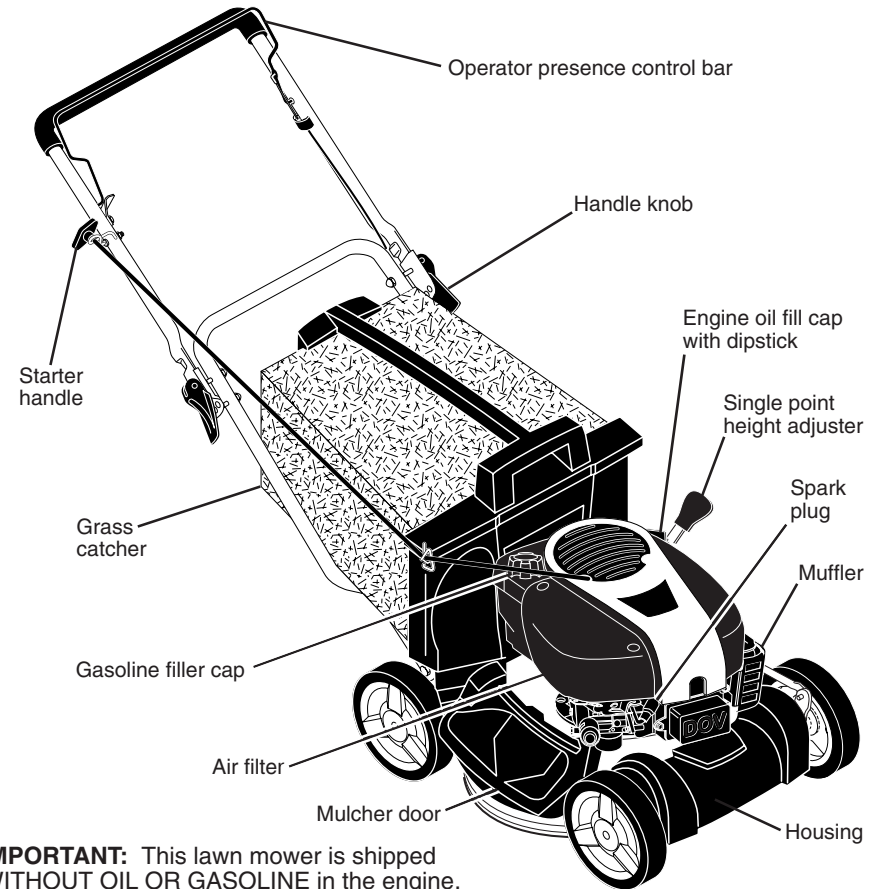
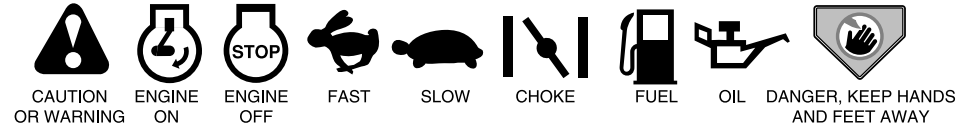

**IMPORTANT:** This lawn mower is shipped WITHOUT OIL OR GASOLINE in the engine.

### MEETS CPSC SAFETY REQUIREMENTS

Sears rotary walk-behind power lawn mowers conform to the safety standards of the American National Standards Institute and the U.S. Consumer Product Safety Commission. The blade turns when the engine is running.

**Operator presence control lever** – must be held down to the handle to start the engine. Release to stop the engine.  
**Starter handle** – used for starting engine.

**Single point height adjuster** – used to adjust cutting height of lawn mower.  
**Mulcher door** – allows conversion to discharging or bagging operation.





The operation of any lawn mower can result in foreign objects thrown into the eyes, which can result in severe eye damage. Always wear safety glasses or eye shields while operating your lawn mower or performing any adjustments or repairs. We recommend standard safety glasses or a wide vision safety mask worn over spectacles.

## HOW TO USE YOUR LAWN MOWER ENGINE SPEED

Engine speed was set at the factory for optimum performance. It is not adjustable.

## ENGINE ZONE CONTROL

**CAUTION:** Federal regulations require an engine control to be installed on this lawn mower in order to minimize the risk of blade contact injury. Do not under any circumstances attempt to defeat the function of the operator control. The blade turns when the engine is running.

- Your lawn mower is equipped with an operator presence control bar which requires the operator to be positioned behind the lawn mower handle to start and operate the lawn mower.

## TO ADJUST CUTTING HEIGHT

All four wheels are adjusted by a single lever.

- Pull adjuster lever toward wheel. To raise mower, move lever forward to desired position. To lower mower, move the lever toward the rear.

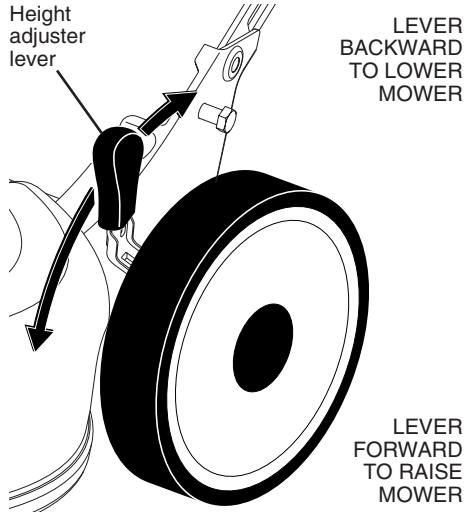

## TO CONVERT MOWER

Your lawn mower was shipped ready to be used as a mulcher. To convert to rear bagging or side discharging:

### REAR BAGGING

- Remove knob securing mulcher door to lawn mower housing.
- Open mulcher door and position discharge chute over both threaded studs.
- Secure discharge chute to lawn mower housing with both knobs.
- Place the grass catcher on the rear door as shown.

**NOTE:** Be sure the grass catcher is securely locked in place.

- Mower is now ready for rear bagging operation.

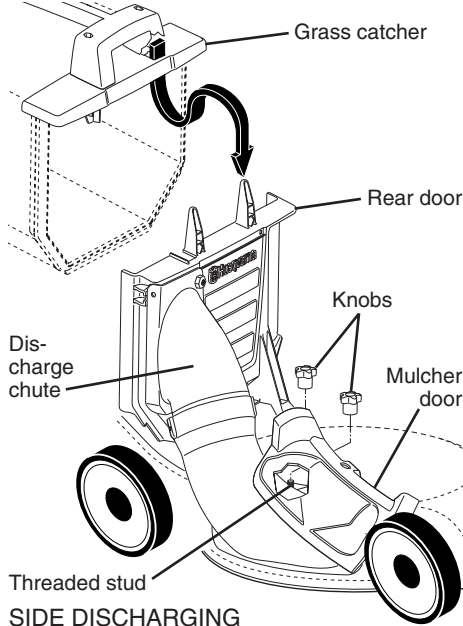

### SIDE DISCHARGING

- Discharge chute must be removed.
  - Open mulcher door and install side discharge deflector beneath it as shown.
  - Secure rear of side discharge deflector to lawn mower housing with knob.
- Mower is now ready for side discharging operation.

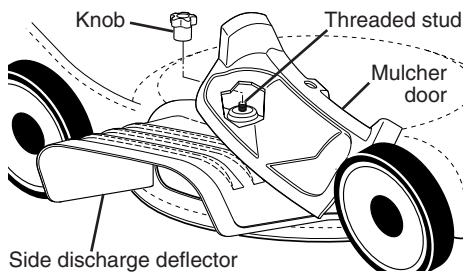

## HUSQVARNA ROTARY LAWN MOWER -- MODEL NUMBER 944.368940

KEY NO.	PART NO.	DESCRIPTION	KEY NO.	PART NO.	DESCRIPTION	KEY NO.	PART NO.	DESCRIPTION	KEY NO.	PART NO.	DESCRIPTION
1	400604	Upper Handle Assembly (Includes Foam Grip)	23	199275X428	Chute, Rear Door	53	191760	Bolt, Hex Head 3/8-24 x 2-1/2	58	418046X418	Discharge Guard
2	186362	Grip, Foam	24	408652	Rope Guide, Rear Door	54	850263	Washer, Helical	59	409314	Mulcher Door Assembly
3	86899X004	Upstop Bracket	26	199272X418	Rear Door	55	851074	Washer, Hardened	60	199268	Hinge Bracket Assembly
4	750634	Screw, Threaded, Rolled #10-24 x 1/2	27	401369	Bolt, Shoulder 5/16	56	199249	Blade Adapter	61	191730	Nut, Hex, Flangelock 1/4-20
5	186298	Control Bar	28	199253X418	Upper Chute	57	150406	Bolt, Engine, Dogpoint 3/8-16	62	183446	Spring, Mulcher Door
6	197740	Cable, Operator Presence	29	199727	Grommet 1/4				63	183445	Rod, Hinge
7	199425X418	Quick Release Assembly	30	199632X418	Lower Chute				64	409310X418	Mulcher Door
8	199697	Rivet	31	199855	Screw, T-30 1/4-20 x 1/2				65	404008	Speed Nut
9	400413	Nut, Acorn	32	401402	Spring, Rear Door				66	850999	Bolt, Hex Head 3/8-16 x 1-1/4
10	199258X498	Bracket, Quick Release	33	199274X418	Handle, Grass Catcher				67	66426	Wire Tie
11	132004	Nut, Hex, Zinc-Plated, Black 1/4-20	34	71090448	Screw 1/4-20 x 3				68	419412	Brace, Support
12	194788	Rope Guide, Upper Handle	35	199277X418	Adapter, Grass Catcher				69	194188	Screw 1/4-20
13	199250X498	Lower Handle	36	183447	Knob				70	400514	Skirt, Rear
14	199255	Stud, Adjustment	37	199422	Screw, Hex Washer Head 1/4-20 x 1/2				--	419475	Manual, Owners, English
15	751153	Nut, Hex 5/16-18	38	199267X418	Rear Cover				--	420548	Manual, Owners, French
17	400136	Grass Catcher Assembly	39	413803	Kit, Lawn Mower Housing						
18	199273	Grass Bag	40	---	Engine, Briggs & Stratton, Model Number 100602-1144-B1 (See Breakdown)						
19	199278	Frame, Grass Bag	41	199771X418	Front Cover						
20	400135	Chute Assembly	42	194189	Screw, Hex Washer Head 3/8-16 x 5/8						
21	163409	Screw, Hi-Lo Thread 1/8 x 5/8	47	199243	Blade						
22	53847	Washer, Flat 1/4									

**NOTE:** All component dimensions given in U.S. inches. 1 inch = 25.4 mm.

**IMPORTANT:** Use only Original Equipment Manufacturer (O.E.M.) replacement parts. Failure to do so could be hazardous, damage your lawn mower and void your warranty.



## REPAIR PARTS

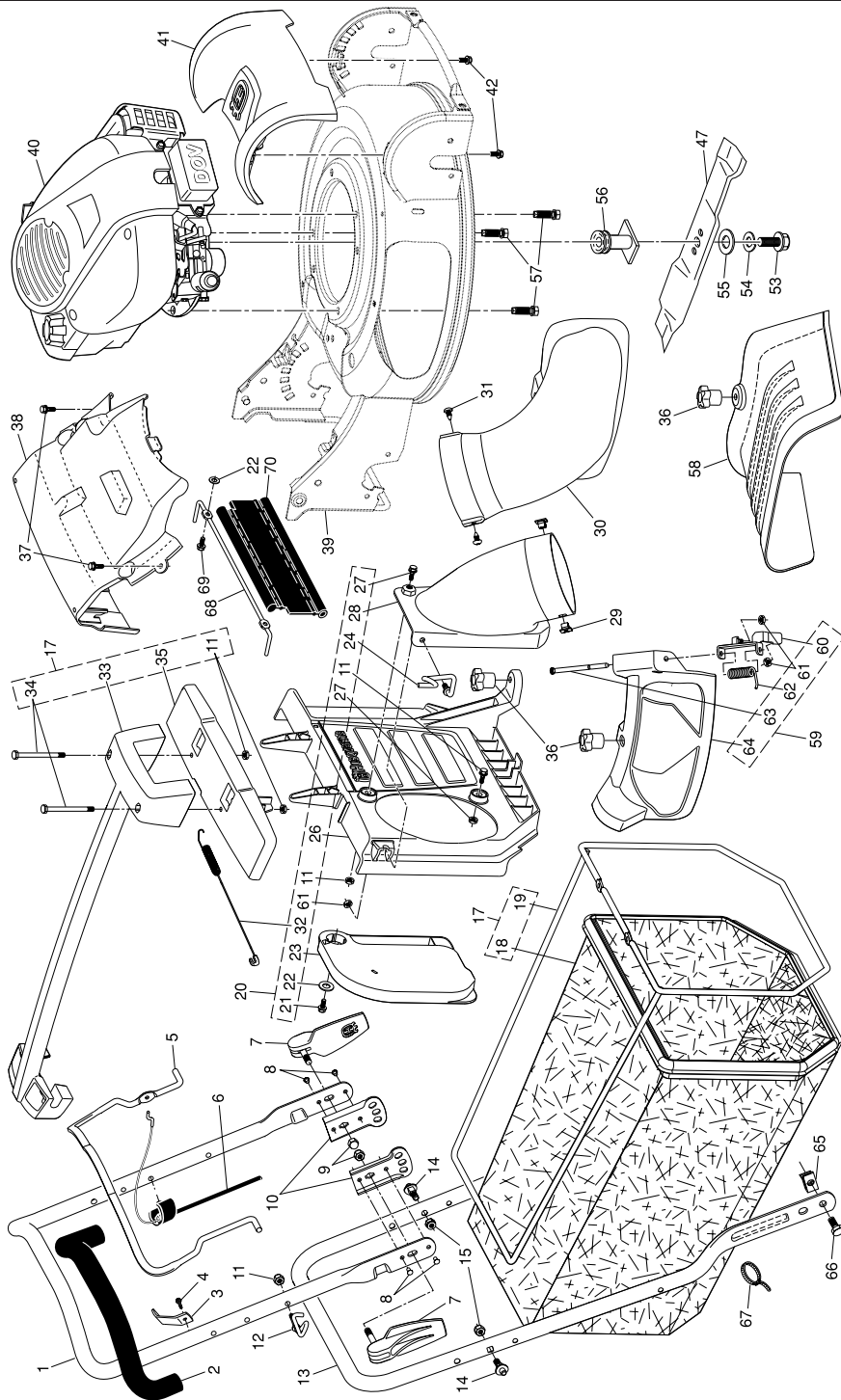

20

HUSQVARNA ROTARY LAWN MOWER -- MODEL NUMBER 944.368940

### SIMPLE STEPS TO REMEMBER WHEN CONVERTING YOUR LAWN MOWER FOR MULCHING -

1. Grass catcher, discharge chute and side discharge deflector removed.
2. Mulcher door secured to mower housing with knob.

### FOR REAR BAGGING -

1. Side discharge deflector removed.
2. Grass catcher and discharge chute installed with discharge chute secured to lawn mower housing with knob.

### FOR SIDE DISCHARGING -

1. Grass catcher and discharge chute removed.
2. Side discharge deflector installed and secured to mower housing with knob.

**CAUTION:** Do not run your lawn mower without mulcher door closed; side discharge deflector installed, or discharge chute and approved grass catcher in place. Never attempt to operate the lawn mower with mulcher door removed or propped open.

### TO EMPTY GRASS CATCHER

1. Remove grass catcher with clippings from lawn mower using both front and center of handle as shown.
  2. Empty clippings from grass catcher.
  3. Reinstall grass catcher on rear door.
- NOTE:** Do not drag the bag when emptying; it will cause unnecessary wear.

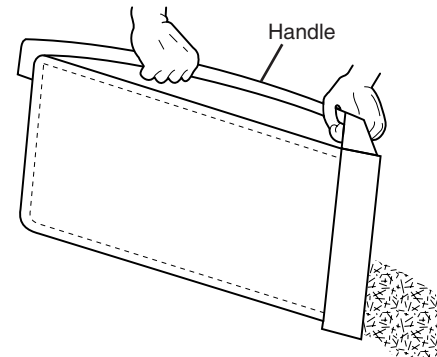

### BEFORE STARTING ENGINE ADD OIL

Your lawnmower is shipped without oil in the engine. For type and grade of oil to use, see "ENGINE" in the Maintenance section of this manual.

**CAUTION:** DO NOT overfill engine with oil, or it will smoke heavily from the muffler on startup.

1. Be sure lawnmower is level.
2. Remove oil dipstick from oil fill spout.

3. You receive a container of oil with the unit. Slowly pour the entire container down the oil fill spout into the engine.

**NOTE:** Initial oil fill requires only 18 oz. due to residual oil in engine from the manufacturers 100% quality testing. When changing oil you may need 20 oz.

4. Insert and tighten dipstick.

### IMPORTANT:

- Check oil level before each use. Add oil if needed. Fill to full line on dipstick.
- Change the oil after every 25 hours of operation or each season. You may need to change the oil more often under dusty, dirty conditions. See "TO CHANGE ENGINE OIL" in the Maintenance section of this manual.

### ADD GASOLINE

- Fill fuel tank to bottom of tank filler neck. Do not overfill. Use fresh, clean, regular unleaded gasoline with a minimum of 87 octane. Do not mix oil with gasoline. Purchase fuel in quantities that can be used within 30 days to assure fuel freshness.

**CAUTION:** Wipe off any spilled oil or fuel. Do not store, spill or use gasoline near an open flame.

**CAUTION:** Alcohol blended fuels (called gasohol or using ethanol or methanol) can attract moisture which leads to separation and formation of acids during storage. Acidic gas can damage the fuel system of an engine while in storage. To avoid engine problems, the fuel system should be emptied before storage of 30 days or longer. Empty the gas tank, start the engine and let it run until the fuel lines and carburetor are empty. Use fresh fuel next season. See Storage Instructions for additional information. Never use engine or carburetor cleaner products in the fuel tank or permanent damage may occur.

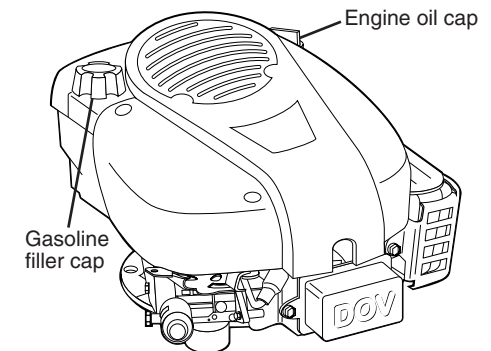

## TO STOP ENGINE

- To stop engine, release operator presence control bar.

## TO START ENGINE

**NOTE:** Due to protective coatings on the engine, a small amount of smoke may be present during the initial use of the product and should be considered normal.

**NOTE:** Your engine is equipped with an automatic choke system. No priming or choking is required before starting.

- To start engine, hold operator presence control bar down to the handle and pull starter handle quickly. Do not allow starter rope to snap back.

## MOWING TIPS

**CAUTION:** Do not use de-thatcher blade attachments on your mower. Such attachments are hazardous, will damage your mower and could void your warranty.

- Under certain conditions, such as very tall grass, it may be necessary to raise the height of cut to reduce pushing effort and to keep from overloading the engine and leaving clumps of grass clippings. It may also be necessary to reduce ground speed and/or run the lawn mower over the area a second time.
- For extremely heavy cutting, reduce the width of cut by overlapping previously cut path and mow slowly.
- For better grass bagging and most cutting conditions, the engine speed should be set in the FAST position.
- Pores in cloth grass catchers can become filled with dirt and dust with use and catchers will collect less grass. To prevent this, regularly hose catcher off with water and let dry before using.
- Keep top of engine around starter clear and clean of grass clippings and chaff. This will help engine air flow and extend engine life.

## MULCHING MOWING TIPS

**IMPORTANT:** For best performance, keep mower housing free of built-up grass and trash. See "CLEANING" in the Maintenance section of this manual.

- The special mulching blade will recut the grass clippings many times and reduce them in size so that as they fall onto the lawn they will disperse into the grass and not be noticed. Also, the mulched grass will biodegrade quickly to provide nutrients for the lawn. Always mulch with your highest engine (blade) speed as this will provide the best recutting action of the blades.
- Avoid cutting your lawn when it is wet. Wet grass tends to form clumps and interferes with the mulching action. The best time to mow your lawn is the early afternoon. At this time the grass has dried, yet the newly cut area will not be exposed to direct sunlight.
- For best results, adjust the lawn mower cutting height so that the lawn mower cuts off only the top one-third of the grass blades. If the lawn is overgrown it will be necessary to raise the height of cut to reduce pushing effort and to keep from overloading the engine and leaving clumps of mulched grass. For extremely heavy grass, reduce your width of cut by overlapping previously cut path and mow slowly.

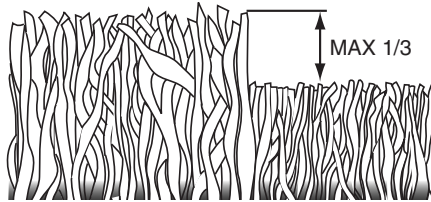

- Certain types of grass and grass conditions may require that an area be mulched a second time to completely hide the clippings. When doing a second cut, mow across (perpendicular) to the first cut path.
- Change your cutting pattern from week to week. Mow north to south one week then change to east to west the next week. This will help prevent matting and graining of the lawn.

## TROUBLESHOOTING - See appropriate section in manual unless directed to a Husqvarna Service Centre.

PROBLEM	CAUSE	CORRECTION
<b>Poor cut – uneven</b>	<ol style="list-style-type: none"> <li>Worn, bent or loose blade.</li> <li>Wheel heights uneven.</li> <li>Buildup of grass, leaves and trash under mower.</li> </ol>	<ol style="list-style-type: none"> <li>Replace blade. Tighten blade bolt.</li> <li>Set all wheels at same height.</li> <li>Clean underside of mower housing.</li> </ol>
<b>Excessive vibration</b>	<ol style="list-style-type: none"> <li>Worn, bent or loose blade.</li> <li>Bent engine crankshaft.</li> </ol>	<ol style="list-style-type: none"> <li>Replace blade. Tighten blade bolt.</li> <li>Contact a Husqvarna or other qualified service centre.</li> </ol>
<b>Starter rope hard to pull</b>	<ol style="list-style-type: none"> <li>Engine flywheel brake is on when control bar is released.</li> <li>Bent engine crankshaft.</li> <li>Blade adapter broken.</li> <li>Blade dragging in grass.</li> </ol>	<ol style="list-style-type: none"> <li>Depress control bar to upper handle before pulling starter rope.</li> <li>Contact a Husqvarna or other qualified service centre.</li> <li>Replace blade adapter.</li> <li>Move lawn mower to cut grass or to hard surface.</li> </ol>
<b>Grass catcher not filling (if so equipped)</b>	<ol style="list-style-type: none"> <li>Cutting height too low.</li> <li>Lift on blade worn off.</li> <li>Catcher not venting air.</li> </ol>	<ol style="list-style-type: none"> <li>Raise cutting height.</li> <li>Replace blade.</li> <li>Clean grass catcher.</li> </ol>
<b>Hard to push</b>	<ol style="list-style-type: none"> <li>Grass is too high or wheel height is too low.</li> <li>Rear of lawn mower housing or cutting blade dragging in grass.</li> <li>Grass catcher too full.</li> <li>Handle height position not right for you.</li> </ol>	<ol style="list-style-type: none"> <li>Raise cutting height.</li> <li>Raise rear of lawn mower housing one (1) setting higher.</li> <li>Empty grass catcher.</li> <li>Adjust handle height to suit.</li> </ol>
<b>Loss of drive or slowing of drive speed</b>	<ol style="list-style-type: none"> <li>Belt wear.</li> <li>Belt off of pulley.</li> <li>Drive cable worn or broken.</li> <li>"Loose" drive control system.</li> </ol>	<ol style="list-style-type: none"> <li>Check/replace drive belt.</li> <li>Check/reinstall drive belt.</li> <li>Replace drive cable.</li> <li>Adjust drive control.</li> </ol>

**TROUBLESHOOTING - See appropriate section in manual unless directed to a Husqvarna Service Centre.**

PROBLEM	CAUSE	CORRECTION
<b>Does not start</b>	<ol style="list-style-type: none"> <li>1. Dirty air filter.</li> <li>2. Out of fuel.</li> <li>3. Stale fuel.</li> <li>4. Water in fuel.</li> <li>5. Spark plug wire is disconnected.</li> <li>6. Bad spark plug.</li> <li>7. Loose blade or broken blade adapter.</li> <li>8. Control bar in released position.</li> <li>9. Control bar defective.</li> <li>10. Fuel valve lever (if so equipped) in OFF position.</li> <li>11. Weak battery (if equipped).</li> <li>12. Disconnected battery connector (if equipped).</li> </ol>	<ol style="list-style-type: none"> <li>1. Clean/replace air filter.</li> <li>2. Fill fuel tank.</li> <li>3. Empty fuel tank and refill tank with fresh, clean gasoline.</li> <li>4. Empty fuel tank and refill tank with fresh, clean gasoline.</li> <li>5. Connect wire to plug.</li> <li>6. Replace spark plug.</li> <li>7. Tighten blade bolt or replace blade adapter.</li> <li>8. Depress control bar to handle.</li> <li>9. Replace control bar.</li> <li>10. Turn fuel valve lever to the ON position.</li> <li>11. Charge battery.</li> <li>12. Connect battery to engine.</li> </ol>
<b>Loss of power</b>	<ol style="list-style-type: none"> <li>1. Rear of lawn mower housing or cutting blade dragging in heavy grass.</li> <li>2. Cutting too much grass.</li> <li>3. Dirty air filter.</li> <li>4. Buildup of grass, leaves, and trash under mower.</li> <li>5. Too much oil in engine.</li> <li>6. Walking speed too fast.</li> </ol>	<ol style="list-style-type: none"> <li>1. Raise cutting height.</li> <li>2. Raise cutting height.</li> <li>3. Clean/replace air filter.</li> <li>4. Clean underside of mower housing.</li> <li>5. Check oil level.</li> <li>6. Cut at slower walking speed.</li> </ol>

**MAINTENANCE**

<b>MAINTENANCE SCHEDULE</b>		BEFORE EACH USE	AFTER EACH USE	EVERY 10 HOURS	EVERY 25 HOURS OR SEASON	EVERY 100 HOURS	BEFORE STORAGE
<b>LAWN MOWER</b>	Check for Loose Fasteners	✓					✓
	Clean / Inspect Grass Catcher *	✓	✓				✓
	Check Tires	✓					
	Check Drive Wheels ***	✓					
	Clean Lawn Mower ****		✓				✓
<b>ENGINE</b>	Clean under Drive Cover ***			✓			
	Check Drive Belt / Pulleys ***				✓		
	Check / Sharpen / Replace Blade				✓ <sub>3</sub>		
	Lubrication				✓		
	Clean and Recharge Battery **				✓		✓ <sub>4</sub>
<b>ENGINE</b>	Check Engine Oil level	✓ <sub>5</sub>					
	Change Engine Oil				✓ <sub>1,2</sub>		
	Clean Air Filter				✓ <sub>2</sub>		
	Inspect Muffler				✓		
	Replace Spark Plug						✓
	Replace Air Filter Paper Cartridge						✓ <sub>2</sub>
	Empty fuel system or add Stabilizer						✓

- \* (if so equipped)
- \*\* Electric-Start mowers
- \*\*\* Power-Propelled mowers
- \*\*\*\* Use a scraper to clean under deck
- 1 - Change more often if operating under a heavy load or in high outdoor temperatures.
- 2 - Service more often if operating in dirty or dusty conditions.
- 3 - Replace blades more often when mowing in sandy soil.
- 4 - Charge 48 hours at end of season.
- 5 - And after each 5 hours of use.

**GENERAL RECOMMENDATIONS**

The warranty on this lawn mower does not cover items that have been subjected to operator abuse or negligence. To receive full value from the warranty, operator must maintain unit as instructed in this manual.

Some adjustments will need to be made periodically to properly maintain your unit.

At least once a season, check to see if you should make any of the adjustments described in the Service and Adjustments section of this manual.

- At least once a year, replace the spark plug, clean or replace air filter element and check blade for wear. A new spark plug and clean/new air filter element assure proper air-fuel mixture and help your engine run better and last longer.
- Follow the maintenance schedule in this manual.

**BEFORE EACH USE**

- Check engine oil level.
- Check for loose fasteners.

**LUBRICATION**

Keep unit well lubricated (See "LUBRICATION CHART").

**LUBRICATION CHART**

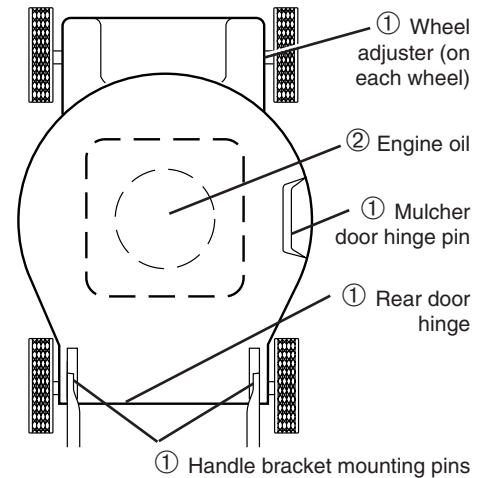

- ① Spray lubricant
- ② See "ENGINE" in Maintenance section.

**IMPORTANT:** Do not oil or grease plastic wheel bearings. Viscous lubricants will attract dust and dirt that will shorten the life of the self-lubricating bearings. If you feel they must be lubricated, use only a dry, powdered graphite type lubricant sparingly.

## LAWN MOWER

Always observe safety rules when performing any maintenance.

## TIRES

- Keep tires free of gasoline, oil, or insect control chemicals which can harm rubber.
- Avoid stumps, stones, deep ruts, sharp objects and other hazards that may cause tire damage.

## BLADE CARE

For best results, mower blade must be kept sharp. Replace a bent or damaged blade.

**CAUTION:** Use only a replacement blade approved by the manufacturer of your mower. Using a blade not approved by the manufacturer of your mower is hazardous, could damage your mower and void your warranty.

### TO REMOVE BLADE

1. Disconnect spark plug wire from spark plug and place wire where it cannot come in contact with plug.
2. Turn lawn mower on its side. Make sure air filter and carburetor are up.
3. Use a wood block between blade and mower housing to prevent blade from turning when removing blade bolt.

**NOTE:** Protect your hands with gloves and/or wrap blade with heavy cloth.

4. Remove blade bolt by turning counter-clockwise.
5. Remove blade and attaching hardware (bolt, lock washer and hardened washer).

### TO REPLACE BLADE

1. Position blade on the blade adapter aligning the two (2) holes in the blade with the raised lugs on the adapter.
  2. Be sure the trailing edge of blade (opposite sharp edge) is up toward the engine.
  3. Install the blade bolt with the lock washer and hardened washer into blade adapter and crankshaft.
  4. Use block of wood between blade and lawn mower housing and tighten the blade bolt, turning clockwise.
- The recommended tightening torque is 45–54 N-m (35–40 ft. lbs.).

**IMPORTANT:** Blade bolt is heat treated. If bolt needs replacing, replace only with approved bolt shown in the Repair Parts section of this manual.

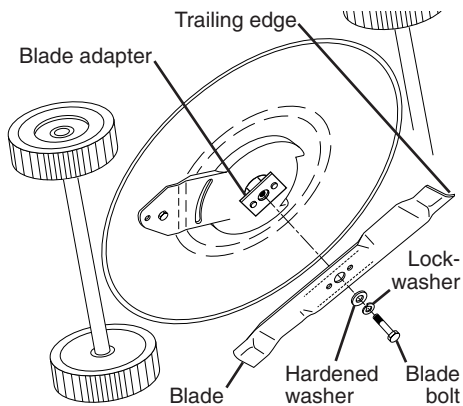

### TO SHARPEN BLADE

**NOTE:** We do not recommend sharpening blade - but if you do, be sure the blade is balanced. An unbalanced blade will cause eventual damage to lawn mower or engine.

- The blade can be sharpened with a file or on a grinding wheel. Do not attempt to sharpen while on the mower.
- To check blade balance, drive a nail into a beam or wall. Leave about one inch of the straight nail exposed. Place center hole of blade over the head of the nail. If blade is balanced, it should remain in a horizontal position. If either end of the blade moves downward, sharpen the heavy end until the blade is balanced.

## GRASS CATCHER

- The grass catcher may be hosed with water, but must be dry when used.
- Check your grass catcher often for damage or deterioration. Through normal use it will wear. If catcher needs replacing, replace only with approved replacement catcher shown in the Repair Parts section of this manual. Give the lawn mower model number when ordering.

## ENGINE LUBRICATION

Use only high quality detergent oil rated with API service classification SG–SL. Select the oil's SAE viscosity grade according to your expected operating temperature.

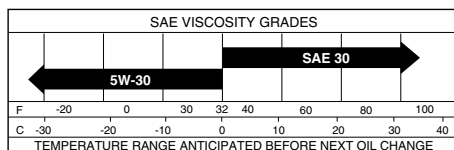

## CYLINDER

1. Remove spark plug.
2. Pour 29 ml of oil through spark plug hole into cylinder.
3. Pull starter handle slowly a few times to distribute oil.
4. Replace with new spark plug.

## OTHER

- Do not store gasoline from one season to another.
- Replace your gasoline can if your can starts to rust. Rust and/or dirt in your gasoline will cause problems.

- If possible, store your unit indoors and cover it to protect it from dust and dirt.
- Cover your unit with a suitable protective cover that does not retain moisture. Do not use plastic. Plastic cannot breathe, which allows condensation to form and will cause your unit to rust.

**IMPORTANT:** Never cover mower while engine and exhaust areas are still warm.

**CAUTION:** Never store the lawn mower with gasoline in the tank inside a building where fumes may reach an open flame or spark. Allow the engine to cool before storing in any enclosure.



## STORAGE

Immediately prepare your lawn mower for storage at the end of the season or if the unit will not be used for 30 days or more.

### LAWN MOWER

When lawn mower is to be stored for a period of time, clean it thoroughly, remove all dirt, grease, leaves, etc. Store in a clean, dry area.

1. Clean entire lawn mower (See "CLEANING" in the Maintenance section of this manual).
2. Lubricate as shown in the Maintenance section of this manual.
3. Be sure that all nuts, bolts, screws, and pins are securely fastened. Inspect moving parts for damage, breakage and wear. Replace if necessary.
4. Touch up all rusted or chipped paint surfaces; sand lightly before painting.

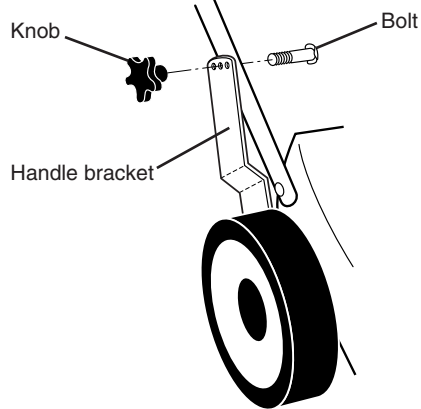

### HANDLE

You can fold your mower handle for storage.

1. Loosen the two (2) handle knobs on sides of the upper handle and allow handle to fold down to the rear.
  2. Remove the two (2) handle knobs and carriage bolts on sides of the lower handle and pivot entire handle assembly forward and allow it to rest on mower.
  3. Reinstall knobs and carriage bolts to lower handle or handle brackets for safe keeping.
- When setting up your handle from the storage position, you must manually lock lower handle into mowing position.

**IMPORTANT:** When folding the handle for storage or transportation, be sure to fold the handle as shown or you may damage the control cables.

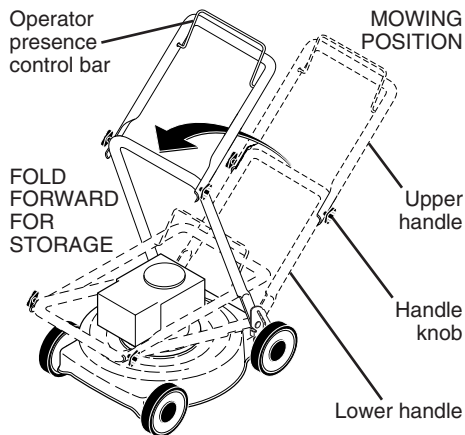

### ENGINE

#### FUEL SYSTEM

**IMPORTANT:** It is important to prevent gum deposits from forming in essential fuel system parts such as carburetor, fuel filter, fuel hose or tank during storage. Alcohol blended fuels (called gasohol or using ethanol or methanol) can attract moisture which leads to separation and formation of acids during storage. Acidic gas can damage the fuel system of an engine while in storage.

- Empty the fuel tank by starting the engine and letting it run until the fuel lines and carburetor are empty.
- Never use engine or carburetor cleaner products in the fuel tank or permanent damage may occur.
- Use fresh fuel next season.

**NOTE:** Fuel stabilizer is an acceptable alternative in minimizing the formation of fuel gum deposits during storage. Add stabilizer to gasoline in fuel tank or storage container. Always follow the mix ratio found on stabilizer container. Run engine at least 10 minutes after adding stabilizer to allow the stabilizer to reach the carburetor. Do not empty the gas tank and carburetor if using fuel stabilizer.

#### ENGINE OIL

Drain oil (with engine warm) and replace with clean engine oil. (See "ENGINE" in the Maintenance section of this manual).

**NOTE:** Although multi-viscosity oils (5W30, 10W30 etc.) improve starting in cold weather, these multi-viscosity oils will result in increased oil consumption when used above 32°F. Check your engine oil level more frequently to avoid possible engine damage from running low on oil. Change the oil after every 25 hours of operation or at least once a year if the lawn mower is not used for 25 hours in one year.

Check the crankcase oil level before starting the engine and after each five (5) hours of continuous use. Tighten oil plug securely each time you check the oil level.

#### TO CHANGE ENGINE OIL

**NOTE:** Before tipping lawn mower to drain oil, empty fuel tank by running engine until fuel tank is empty.

1. Disconnect spark plug wire from spark plug and place wire where it cannot come in contact with plug.
2. Remove engine oil cap; lay aside on a clean surface.
3. Tip lawn mower on its side as shown and drain oil into a suitable container. Rock lawn mower back and forth to remove any oil trapped inside of engine.

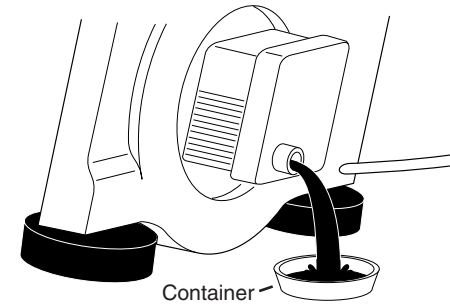

4. Wipe off any spilled oil from lawn mower or side of engine.
5. Slowly pour oil down the oil fill spout, stopping every few ounces to check the oil level with the dipstick.
6. Stop adding oil when you reach the FULL mark on the dipstick. Wait a minute to allow oil to settle.
7. Continue adding small amounts of oil, rechecking the dipstick until oil level settles at FULL. DO NOT overfill, or engine will smoke heavily from the muffler on startup.
8. Always be sure to retighten oil dipstick before starting engine.
9. Reconnect spark plug wire to plug.

### AIR FILTER

Your engine will not run properly using a dirty air filter. Replace paper cartridge every 100 hours of operation or every season, whichever occurs first. Service air cleaner more often under dusty conditions.

1. Loosen screws and remove cover.
2. Carefully remove cartridge.
3. Clean by gently tapping on a flat surface. If very dirty, replace cartridge.

**CAUTION:** Petroleum solvents, such as kerosene, are not to be used to clean cartridge. They may cause deterioration of the cartridge. Do not oil cartridge. Do not use pressurized air to clean or dry cartridge.

4. Install cartridge, then replace cover.

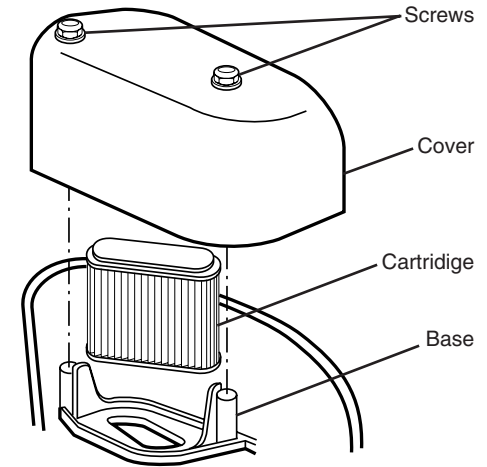

### MUFFLER

Inspect and replace corroded muffler as it could create a fire hazard and/or damage.

### SPARK PLUG

Replace spark plug at the beginning of each mowing season or after every 100 hours of operation, whichever occurs first. Spark plug type and gap setting are shown in the "PRODUCT SPECIFICATIONS" section of this manual.

## CLEANING

**IMPORTANT:** For best performance, keep mower housing free of built-up grass and trash. Clean the underside of your mower after each use.

- Clean engine often to keep trash from accumulating. A clogged engine runs hotter and shortens engine life.
- Keep finished surfaces and wheels free of all gasoline, oil, etc.
- We do not recommend using a garden hose to clean the outside of your lawn mower unless the electrical system, muffler, air filter and carburetor are covered to keep water out. Water in engine can result in shortened engine life.

## WATER WASHOUT FEATURE

Your lawn mower is equipped with a quick-connect fitting that allows quick and easy cleaning of the underside of the housing. To use this feature, proceed as follows:

1. Move lawn mower to an area of cut grass or another hard surface.

**NOTE:** Water, grass and other debris will drain from beneath the mower housing during the washout process.

2. Remove grass catcher and discharge chute assembly from lawn mower.
3. Close mulcher door, secure with knob.
4. Connect a garden hose to the quick-release fitting where shown.

**IMPORTANT:** Be sure the garden hose is not routed under the lawn mower housing or entangled in the wheels.

5. Turn on water supply and check for leaks at the quick-release fitting.

If no leaks are present, start engine (as described in the Operation section of this manual) and let engine run until the underside of the lawn mower is clean.

**⚠ WARNING:** Do not engage the drive system during the washout process.

6. Shut off the engine.
7. Shut off water supply and remove hose from quick-release fitting.

**CAUTION:** Do not remove hose from fitting while engine is running. Water in engine can result in shortened engine life.

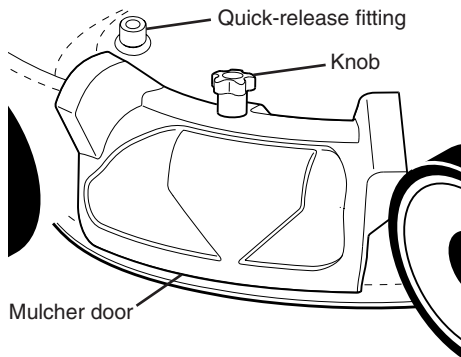

## SERVICE AND ADJUSTMENTS

**⚠ WARNING:** To avoid serious injury, before performing any service or adjustments:

1. Release control bar and stop engine.
2. Make sure the blade and all moving parts have completely stopped.
3. Disconnect spark plug wire from spark plug and place wire where it cannot come in contact with plug.

### LAWN MOWER

#### TO ADJUST CUTTING HEIGHT

See "TO ADJUST CUTTING HEIGHT" in the Operation section of this manual.

#### REAR DEFLECTOR

The rear deflector, attached between the rear wheels of your mower, is provided to minimize the possibility that objects will be thrown out of the rear of the mower into the operator mowing position. If the deflector becomes damaged, it should be replaced.

#### TO ADJUST LOWER HANDLE

The handle on your lawn mower has multiple height positions - adjust to height that suits you.

1. Remove knob and carriage bolt on one side of the lower handle.
2. While holding handle assembly, remove knob and carriage bolt from opposite side, align hole in handle with desired hole in handle bracket and reassemble bolt and knob and tighten securely.
3. Align opposite side of handle with same positioning hole and secure with bolt and knob.

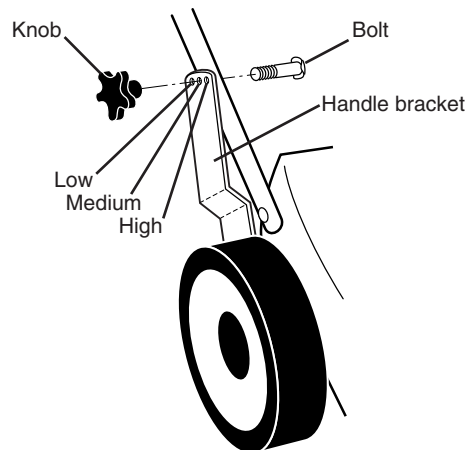

#### TO ADJUST UPPER HANDLE

The upper handle may be adjusted to three (3) different height positions.

1. Loosen both handle levers enough to allow the upper handle to pivot to the desired adjustment position.
2. Tighten both handle levers securely.

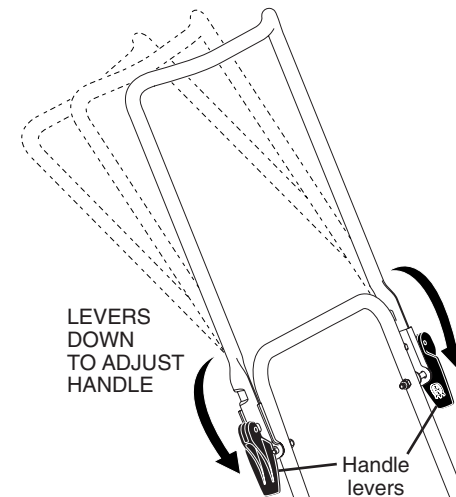

### ENGINE ENGINE SPEED

Your engine speed has been factory set. Do not attempt to increase engine speed or it may result in personal injury. If you believe that the engine is running too fast or too slow, take your lawn mower to a Husqvarna or other qualified service centre for repair and adjustment.

### CARBURETOR

Your carburetor is not adjustable. If your engine does not operate properly due to suspected carburetor problems, take your lawn mower to a Husqvarna or other qualified service centre for repair or adjustment.

**IMPORTANT:** Never tamper with the engine governor, which is factory set for proper engine speed. Overspeeding the engine above the factory high speed setting can be dangerous. If you think the engine-governed high speed needs adjusting, contact a Husqvarna or other qualified service centre, which has proper equipment and experience to make any necessary adjustments.