

Get it fixed, at your home or ours!

Just Call:

**1-800-4-MY-HOME®**

(1-800-469-4663)

24 hours a day, 7 days a week

For the repair of major brand appliances **in your own home...**  
no matter who made it, no matter who sold it!

For your nearest **Sears Parts and Service** location,  
to bring in products like vacuums, lawn equipment and electronics.

For **Sears Parts & Service**, to order the replacement parts,  
accessories and owner's manuals that you need to do-it-yourself.

[www.sears.ca](http://www.sears.ca)

To purchase or inquire about a Sears Maintenance Agreement, call:

**1-800-361-6665**

9 a.m. – 11 p.m. Mon. – Fri., EST, 9 a.m. – 4 p.m. Sat.

Pour service en français:

**1-800-LE-FOYER<sup>MC</sup>**

(1-800-533-6937)

[www.sears.ca](http://www.sears.ca)



® / <sup>TM</sup> Trademarks of Sears, Roebuck and Co. used under license by Sears Canada

<sup>MD</sup> Marque déposée / <sup>MC</sup> Marque de commerce de Sears, Roebuck and Co. utilisée en vertu d'une licence de Sears Canada

Owner's Manual



## ROTARY LAWN MOWER

675 Series Briggs & Stratton Engine

Power-Propelled

22" Multi-Cut

Model No.

**944.369610**



### CAUTION:

Read and follow all  
Safety Rules and Instructions  
before operating this equipment

Sears Canada, Inc., Toronto, Ontario M5B 2B8

## TABLE OF CONTENTS

Warranty .....	2	Maintenance.....	11-14
Safety Rules .....	2-3	Service and Adjustments.....	15-16
Product Specifications .....	4	Storage.....	16-17
Assembly/Pre-Operation .....	4-5	Troubleshooting.....	18-19
Operation.....	6-10	Repair Parts.....	20-26
Maintenance Schedule.....	11	Sears Service .....	Back Cover

## WARRANTY

### LIMITED TWO YEAR WARRANTY ON CRAFTSMAN POWER MOWER

For Two years from date of purchase Sears Canada, Inc. will repair or replace at Sears option free of charge parts which are defective as a result of material or workmanship.

### COMMERCIAL OR RENTAL USE:

Warranty on Power Mower (Gas) will be ninety (90) days from date of purchase if used for commercial or rental purposes.

This Warranty does NOT cover:

- Pre-delivery set-up.
- In-home service
- Expendable items which become worn during normal use, such as rotary mower blades, blade adapters, belts, air cleaners and spark plug.
- Repairs necessary because of operator abuse or negligence, including bent crankshafts and the failure to maintain the equipment according to the instructions contained in the owner's manual.

Warranty service is available by returning the Craftsman Power Mower to the nearest Sears Service Centre/Department in Canada. This warranty applies only while this product is used in Canada.

This warranty is in addition to any statutory warranty and does not exclude or limit legal rights you may have but shall run concurrently with applicable provincial legislation. Furthermore, some provinces do NOT allow limitation on how long an implied warranty will last so the above limitations may not apply to you.

Sears Canada, Inc., Toronto, Ontario M5B 2B8

## SAFETY RULES

**IMPORTANT:** This cutting machine is capable of amputating hands and feet and throwing objects. Failure to observe the following safety instructions could result in serious injury or death.

⚠ Look for this symbol to point out important safety precautions. It means CAUTION!!! BECOME ALERT!!! YOUR SAFETY IS INVOLVED.

⚠ **WARNING:** In order to prevent accidental starting when setting up, transporting, adjusting or making repairs, always disconnect spark plug wire and place wire where it cannot come in contact with plug.

⚠ **CAUTION:** Muffler and other engine parts become extremely hot during operation and remain hot after engine has stopped. To avoid severe burns on contact, stay away from these areas.

### I. GENERAL OPERATION

- Read, understand, and follow all instructions on the machine and in the manual(s) before starting. Be thoroughly familiar with the controls and the proper use of the machine before starting.
- Do not put hands or feet near or under rotating parts. Keep clear of the discharge opening at all times.
- Only allow responsible individuals, who are familiar with the instructions, to operate the machine.
- Clear the area of objects such as rocks, toys, wire, bones, sticks, etc., which could be picked up and thrown by blade.
- Be sure the area is clear of other people before mowing. Stop machine if anyone enters the area.
- Do not operate the mower when bare-foot or wearing open sandals. Always wear substantial foot wear.



## SERVICE NOTES

- Do not pull mower backwards unless absolutely necessary. Always look down and behind before and while moving backwards.
- Never direct discharged material toward anyone. Avoid discharging material against a wall or obstruction. Material may ricochet back toward the operator. Stop the blade when crossing gravel surfaces.
- Do not operate the mower without proper guards, plates, grass catcher or other safety protective devices in place.
- See manufacturer's instructions for proper operation and installation of accessories. Only use accessories approved by the manufacturer.
- Stop the blade(s) when crossing gravel drives, walks, or roads.
- Stop the engine (motor) whenever you leave the equipment, before cleaning the mower or unclogging the chute.
- Shut the engine (motor) off and wait until the blade comes to complete stop before removing grass catcher.
- Mow only in daylight or good artificial light.
- Do not operate the machine while under the influence of alcohol or drugs.
- Never operate machine in wet grass. Always be sure of your footing: keep a firm hold on the handle; walk, never run.
- Disengage the self-propelled mechanism or drive clutch on mowers so equipped before starting the engine.
- If the equipment should start to vibrate abnormally, stop the engine (motor) and check immediately for the cause. Vibration is generally a warning of trouble.
- Always wear safety goggles or safety glasses with side shields when operating mower.

### II. SLOPE OPERATION

Slopes are a major factor related to slip & fall accidents which can result in severe injury. All slopes require extra caution. If you feel uneasy on a slope, do not mow it.

#### DO:

- Mow across the face of slopes: never up and down. Exercise extreme caution when changing direction on slopes.
- Remove obstacles such as rocks, tree limbs, etc.
- Watch for holes, ruts, or bumps. Tall grass can hide obstacles.

#### DO NOT:

- Do not trim near drop-offs, ditches or embankments. The operator could lose footing or balance.

- Do not trim excessively steep slopes.
- Do not mow on wet grass. Reduced footing could cause slipping.

### III. CHILDREN

Tragic accidents can occur if the operator is not alert to the presence of children. Children are often attracted to the machine and the mowing activity. *Never* assume that children will remain where you last saw them.

- Keep children out of the trimming area and under the watchful care of another responsible adult.
- Be alert and turn machine off if children enter the area.
- Before and while walking backwards, look behind and *down* for small children.
- Never allow children to operate the machine.
- Use extra care when approaching blind corners, shrubs, trees, or other objects that may obscure vision.

### IV. SAFE HANDLING OF GASOLINE

Use extreme care in handling gasoline. Gasoline is extremely flammable and the vapors are explosive.

- Extinguish all cigarettes, cigars, pipes and other sources of ignition.
- Use only an approved container.
- Never remove gas cap or add fuel with the engine running. Allow engine to cool before refueling.
- Never refuel the machine indoors.
- Never store the machine or fuel container where there is an open flame, spark or pilot light such as a water heater or on other appliances.
- Never fill containers inside a vehicle, on a truck or trailer bed with a plastic liner. Always place containers on the ground away from your vehicle before filling.
- Remove gas-powered equipment from the truck or trailer and refuel it on the ground. If this is not possible, then refuel such equipment with a portable container, rather than from a gasoline dispenser nozzle.
- Keep the nozzle in contact with the rim of the fuel tank or container opening at all times until fueling is complete. Do not use a nozzle lock-open device.
- If fuel is spilled on clothing, change clothing immediately.
- Never overfill fuel tank. Replace gas cap and tighten securely.

## V. GENERAL SERVICE

- Never run machine inside a closed area.
- Never make adjustments or repairs with the engine (motor) running. Disconnect the spark plug wire, and keep the wire away from the plug to prevent accidental starting.
- Keep nuts and bolts, especially blade attachment bolts, tight and keep equipment in good condition.
- Never tamper with safety devices. Check their proper operation regularly.
- Keep machine free of grass, leaves, or other debris build-up. Clean oil or fuel spillage. Allow machine to cool before storing.
- Stop and inspect the equipment if you strike an object. Repair, if necessary, before restarting.
- Never attempt to make wheel height adjustments while the engine is running.
- Grass catcher components are subject to wear, damage, and deterioration, which could expose moving parts or allow objects to be thrown. Frequently check components and replace with manufacturer's recommended parts, when necessary.
- Mower blades are sharp and can cut. Wrap the blade(s) or wear gloves, and use extra caution when servicing them.
- Do not change the engine governor setting or overspeed the engine.
- Maintain or replace safety and instruction labels, as necessary.

**⚠ WARNING:** This lawn mower is equipped with an internal combustion engine and should not be used on or near any unimproved forest-covered, brush-covered or grass-covered land unless the engine's exhaust system is equipped with a spark arrester meeting applicable local or state laws (if any). If a spark arrester is used, it should be maintained in effective working order by the operator. A spark arrester for the muffler is available through your nearest Sears Service Centre (See the REPAIR PARTS section of this manual).

## PRODUCT SPECIFICATIONS

Serial Number:	
Date of Purchase:	
Gasoline Capacity / Type:	1,5 Litres (Unleaded Regular)
Oil Capacity:	0,58 Litres
Oil Type (API SG–SL):	SAE 30 (above 0°C/32°F); SAE 5W-30 (below 0°C/32°F)
Spark Plug:	Champion RJ19HX (Gap: 0,76 mm)
Blade Bolt Torque:	35-40 ft. lbs.
• The model and serial numbers will be found on a decal on the rear of the lawn mower housing. Record both serial number and date of purchase in space provided above.	

## ASSEMBLY / PRE-OPERATION

Read these instructions and this manual in its entirety before you attempt to assemble or operate your new lawn mower.

**IMPORTANT:** This lawn mower is shipped WITHOUT OIL OR GASOLINE in the engine.

Your new lawn mower has been assembled at the factory with the exception of those parts left unassembled for shipping purposes. To ensure safe and proper operation of your lawn mower, all parts and hardware you assemble must be tightened securely. Use the correct tools as necessary to ensure proper tightness. All parts such as nuts, washers, bolts, etc.,

necessary to complete the assembly have been placed in the parts bag.

### TO REMOVE MOWER FROM CARTON

1. Remove loose parts included with mower.
2. Cut down two end corners of carton and lay end panel down flat.
3. Remove all packing materials except padding between upper and lower handle and padding holding operator presence control bar to upper handle.
4. Roll lawn mower out of carton and check carton thoroughly for additional loose parts.

4

KEY PART NO.	NO.	DESCRIPTION	KEY PART NO.	NO.	DESCRIPTION
404	690272	Washer (Governor Crank)	871	262001	Bushing-Valve Guide (Exhaust Valve)
425	690670	Screw (Air Cleaner Cover)		63709	Bushing-Valve Guide (Intake Valve)
443	692523	Screw (Air Cleaner Primer Base)	883	691881	+• Gasket-Exhaust
445	491588s	Filter-Air Cleaner Cartridge	921	796906	Cup-Blower Housing
455	791960	Cup-Flywheel	922	692135	Spring-Brake
456	692299	Plate-Pawl Friction	923	796136	Brake
459	281505s	Pawl-Ratchet	957	793606	Cap-Fuel Tank
505	691251	Nut (Governor Control Lever)	966	795259	Base-Air Cleaner Primer
523	499621	Dipstick	968	692298	Cover-Air Cleaner
524	692296	• Seal- Dipstick Tube	969	690700	Screw (Blower Cover)
525	495265	Tube-Dipstick	972	699374	Tank-Fuel
562	691119	Bolt (Governor Control Lever)	975	796611	Bowl-Fuel
564	698589	Screw (Control Cover)	1036	- - -	Label-Emissions (Available From any Briggs & Stratton Authorized Dealer)
584	697734	Cover-Breather Passage	1058	277039	Operator's Manual
585	691879	• Gasket-Breather Passage	1059	692311	Kit-Screw / Washer (Fuel Tank)
592	690800	Nut (Rewind Starter)	1095	498528	Gasket Set-Valve
597	691696	Screw (Pawl Friction Plate)	1210	498144	Pulley / Spring Assembly (Pulley)
601	791850	Clamp-Hose (Green)	1211	498144	Pulley / Spring Assembly (Spring)
604	790703	Cover-Control	1329	126L02-1625-F1	Replacement Engine
608	497680	Starter-Rewind	1330	270962	Repair Manual
613	790833	Screw (Muffler)	1386	790848	Vane-Air
615	690340	Retainer-Governor Shaft	1387	790849	Spring-Air Vane
616	698801	Crank-Governor	1388	790850	Screw (Air Vane)
617	270344s	* Seal-O Ring (Intake Manifold)	- -	398067	Spark Arrester (available accessory)
621	692310	Switch-Stop (Brake)	*		Included in Carburetor Overhaul Kit, Key Number 121
633	691321	* Seal-Choke / Throttle Shaft (Throttle Shaft)	•		Included in Engine Gasket Set, Key Number 358
633A	693867	Seal-Choke / Throttle Shaft (Choke Shaft)	+		Included in Valve Gasket Set, Key Number 1095
635	66538s	Boot-Spark Plug	<b>NOTE:</b>		All component dimensions given in U.S. inches.
684	690345	Screw (Breather Passage Cover)			1 inch = 25.4 mm
689	691855	Spring-Friction			
718	690959	Pin-Locating			
741	795755	Gear-Timing			
745	691648	Screw (Brake)			
847	692047	Dipstick/Tube Assembly			
851	493880s	Terminal-Spark Plug			
868	697338	• Seal-Valve			
869	691155	Seat-Valve (Intake)			
870	690380	Seat-Valve (Exhaust)			



KEY PART NO. NO.	DESCRIPTION	KEY PART NO. NO.	DESCRIPTION
1	697322 Cylinder Assembly	54	691650 Screw (Intake Manifold)
2	399269 Kit-Bushing / Seal (Magneto Side)	55	691421 Housing-Rewind Starter
3	299819s • Seal-Oil (Magneto Side)	58	697316 Rope-Starter
4	493279 Sump-Engine	60	795426 Grip-Starter Rope
5	691160 Head-Cylinder	65	690837 Screw (Rewind Starter)
7	692249 •+ Gasket-Cylinder Head	78	691108 Screw (Flywheel Guard)
8	695250 Breather Assembly	81	691740 Lock-Muffler Screw
9	699472 + Gasket-Breather	97	696565 Shaft-Throttle
10	691125 Screw (Breather Assembly)	104	691242 * Pin-Float Hinge
11	691781 Tube-Breather	108	795935 Valve-Choke
11A	691923 Tube-Breather	109	795936 Shaft-Choke
12	692232 • Gasket-Crankcase	117	695042 Jet-Main (Standard)
13	690912 Screw (Cylinder Head)	121	796112 Kit-Carburetor Overhaul
15	691680 Plug-Oil Drain	125	794304 Carburetor
16	691450 Crankshaft	127	694468 * Plug-Welch
20	399781s • Seal-Oil (PTO Side)	130	696564 Valve-Throttle
22	691092 Screw (Crankcase Cover/Sump)	133	398187 Float-Carburetor
23	691987 Flywheel	134	398188 * Kit-Needle/Seat
24	222698s Key-Flywheel	137	796610 * Gasket-Float Bowl
25	795429 Piston Assembly (Standard)	163	795629 •* Gasket-Air Cleaner
	795430 Piston Assembly (.020" Oversize)	177	691031 • Seal-O Ring (Dipstick)
26	795431 Ring Set (Standard Size)	187	791766 Line-Fuel (Cut To Required Length)
	795432 Ring Set (.020" Oversize)	188	693999 Screw (Control Bracket)
27	691866 Lock-Piston Pin	190	690940 Screw (Fuel Tank)
28	499423 Pin-Piston	202	691829 Link-Mechanical Governor
29	499424 Rod-Connecting	209	699056 Spring-Governor (No Color)
32	691664 Screw (Connecting Rod) (Short)	222	795937 Bracket-Control
32A	695759 Screw (Connecting Rod) (Long)	227	690783 Lever-Governor Control
33	262651s Valve-Exhaust	276	271716 * Washer-Sealing (Main Jets)
34	262652s Valve-Intake	287	690940 Screw (Dipstick Tube)
35	691270 Spring-Valve (Intake)	291	790830 Thermostat
36	691270 Spring-Valve (Exhaust)	300	790828 Muffler
37	793756 Guard-Flywheel	304	790826 Housing-Blower
40	692194 Retainer-Valve	305	691108 Screw (Blower Housing)
43	691997 Slinger-Governor/Oil	306	790836 Shield-Cylinder
45	690548 Tappet-Valve	307	690345 Screw (Cylinder Shield)
46	691449 Camshaft	332	690662 Nut (Flywheel)
48	792741 Short Block	333	793354 Armature-Magneto
50	794305 Manifold-Intake	334	691061 Screw (Magneto Armature)
51	794306 • Gasket-Intake	337	796112s Plug-Spark
		356	692390 Wire-Stop
		358	794307 Gasket Set-Engine
		362	793351 Shield-Spark Plug
		365	691688 Screw (Carburetor)

HOW TO SET UP YOUR MOWER

TO UNFOLD HANDLE

**IMPORTANT:** Unfold handle carefully so as not to pinch or damage control cables.

1. Raise handles until lower handle section locks into place in mowing position.
2. Remove protective padding, raise upper handle section into place on lower handle and tighten both handle knobs.
3. Remove handle padding holding operator presence control bar to upper handle.

Your lawn mower handle can be adjusted for your mowing comfort. Refer to "ADJUST HANDLE" in the Service and Adjustments section of this manual.

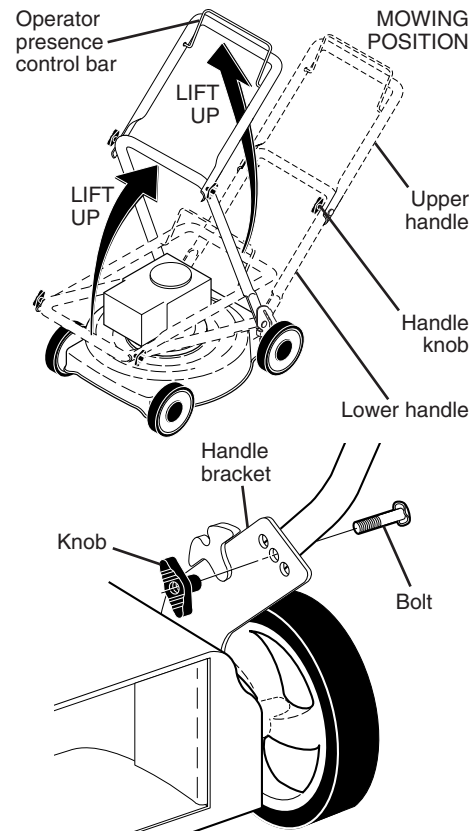

TO ASSEMBLE GRASS CATCHER

1. Put grass catcher frame into grass bag with rigid part of bag on the bottom. Make sure the frame handle is outside of the bag top.
2. Slip vinyl bindings over frame.

**NOTE:** If vinyl bindings are too stiff, hold them in warm water for a few minutes. If bag gets wet, let it dry before using.

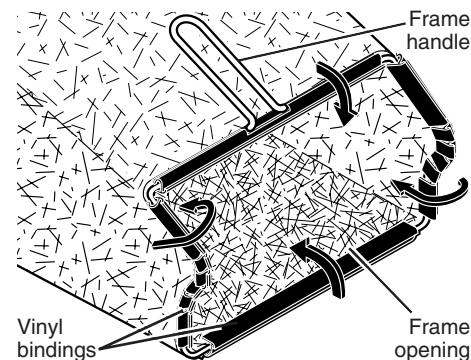

TO INSTALL ATTACHMENTS

Your lawn mower was shipped ready to be used as a mulcher. To convert mower to bagging or discharging, see "TO CONVERT MOWER" in the Operation section of this manual.

# OPERATION

## KNOW YOUR LAWN MOWER

READ THIS OWNER'S MANUAL AND ALL SAFETY RULES BEFORE OPERATING YOUR LAWN MOWER. Compare the illustrations with your lawn mower to familiarize yourself with the location of various controls and adjustments. Save this manual for future reference.

These symbols may appear on your lawn mower or in literature supplied with the product. Learn and understand their meaning.

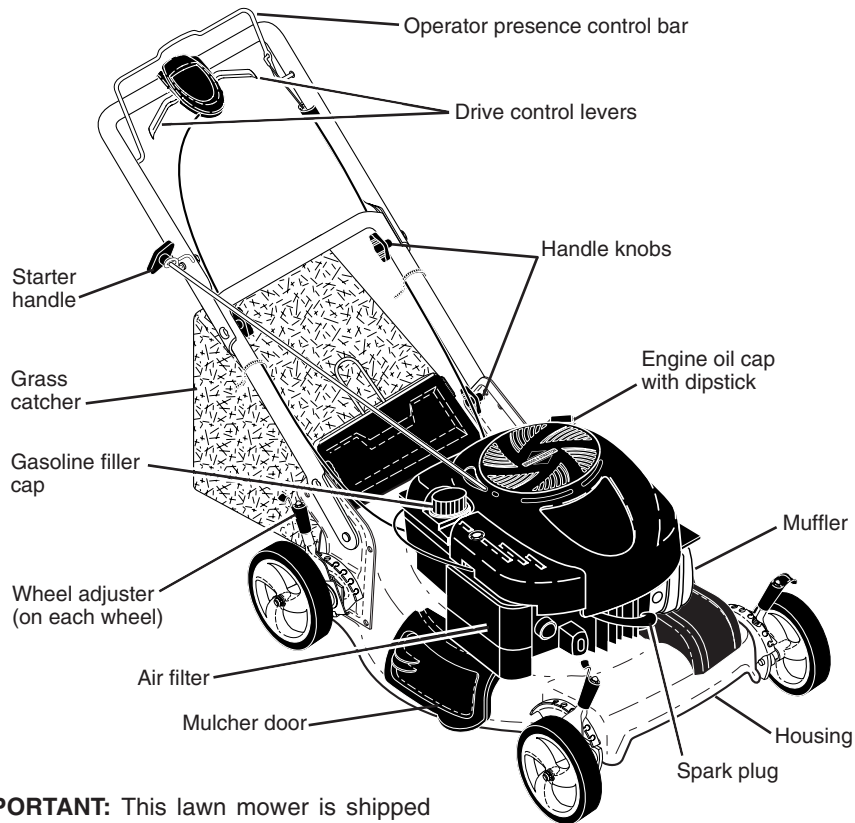
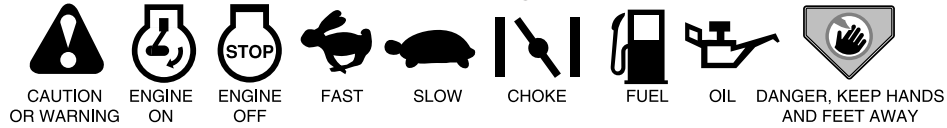

**IMPORTANT:** This lawn mower is shipped WITHOUT OIL OR GASOLINE in the engine.

### MEETS CPSC SAFETY REQUIREMENTS

Sears rotary walk-behind power lawn mowers conform to the safety standards of the American National Standards Institute and the U.S. Consumer Product Safety Commission. The blade turns when the engine is running.

**Operator presence control bar** – must be held down to the handle to start the engine. Release to stop the engine.  
**Starter handle** – used for starting engine.

**Drive control levers** – used to engage power-propelled forward motion of mower.  
**Mulcher door** – allows conversion to discharging or bagging operation.

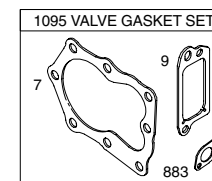
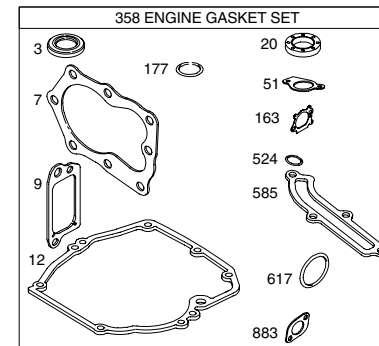
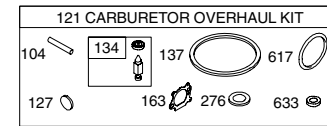

### Engine Power Rating Information

The gross power rating for individual gas engine models is labeled in accordance with SAE (Society of Automotive Engineers) code J11940 (Small Engine Power & Torque Rating Procedure), and rating performance has been obtained and corrected in accordance with SAE J1995 (Revision 2002-5). Actual gross engine power will be lower and is affected by, among other things, ambient operating conditions and engine-to-engine variability. Given both the wide array of products on which engines are placed and the variety of environmental issues applicable to operating the equipment, the gas engine will not develop the rated gross power when used in a given piece of power equipment (actual "on-site" or net horsepower). This difference is due to a variety of factors including, but not limited to, accessories (air cleaner, exhaust, charging, cooling, carburetor, fuel pump, etc.), application limitations, ambient operating conditions (temperature, humidity, altitude), and engine-to-engine variability. Due to manufacturing and capacity limitations, Briggs & Stratton may substitute an engine of higher rated power for this Series engine.

1036 EMISSIONS LABEL

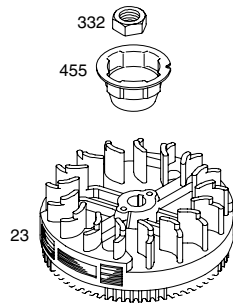
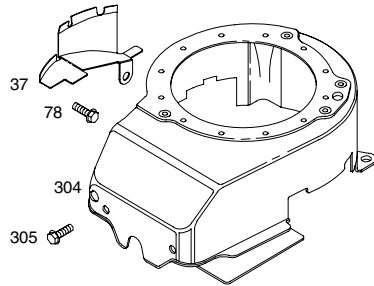
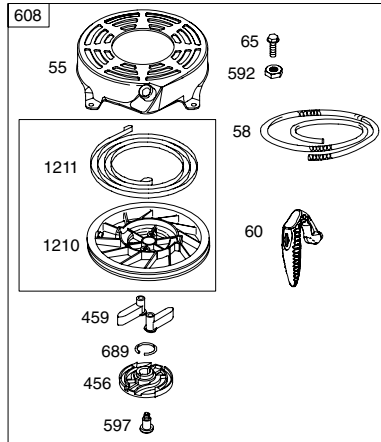
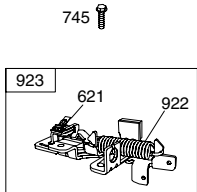
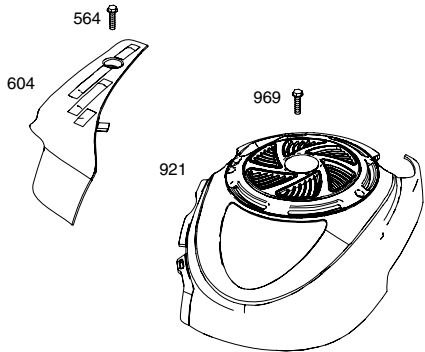
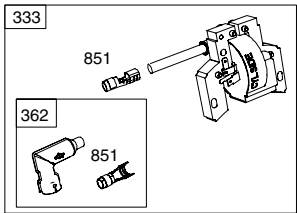
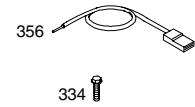

The operation of any lawn mower can result in foreign objects thrown into the eyes, which can result in severe eye damage. Always wear safety glasses or eye shields while operating your lawn mower or performing any adjustments or repairs. We recommend a standard safety glasses or wide vision safety mask worn over spectacles.

**HOW TO USE YOUR LAWN MOWER ENGINE SPEED**

Engine speed was set at the factory for optimum performance. It is not adjustable.

**ENGINE ZONE CONTROL**

**CAUTION:** Federal regulations require an engine control to be installed on this lawn mower in order to minimize the risk of blade contact injury. Do not under any circumstances attempt to defeat the function of the operator control. The blade turns when the engine is running.

- Your lawn mower is equipped with an operator presence control bar which requires the operator to be positioned behind the lawn mower handle to start and operate the lawn mower.

**DRIVE CONTROL**

- Self-propelling is controlled by holding the operator presence control bar down to the handle and pulling either drive control lever rearward to the handle. The further toward the handle a lever is pulled, the faster the unit will travel.
- Forward motion will stop when either the operator presence control bar or a drive control lever are released. To stop forward motion without stopping engine, release a drive control lever only. Hold operator presence control bar down against handle to continue mowing without self-propelling.

**NOTE:** If after releasing the drive control the mower will not roll backwards, push the mower forward slightly to disengage drive wheels.

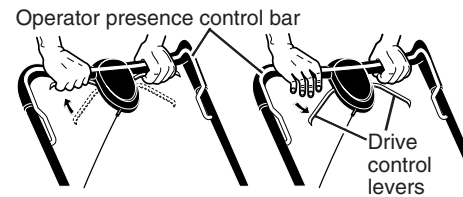

TO ENGAGE DRIVE CONTROL

DRIVE CONTROL DISENGAGED

**DRIVE CONTROL ADJUSTMENT**

Over time, the drive control system may become "loose", resulting in decreased speed. There is a turnbuckle on the drive control housing to increase tension on the drive cable. Proceed as follows:

- Turn unit off and disconnect spark plug wire from spark plug.
- Rotate turnbuckle on drive control to increase drive speed.
- Operate mower to test drive speed. Readjust as required.
- If condition fails to improve after the above steps (forward speed remains the same), your drive belt is worn and should be replaced.

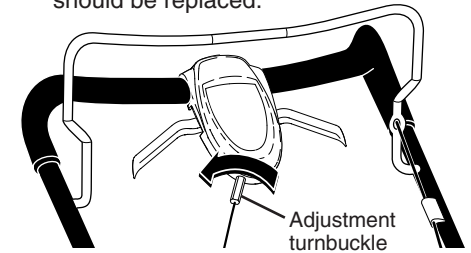

**TO ADJUST CUTTING HEIGHT**

Raise wheels for low cut and lower wheels for high cut, adjust cutting height to suit your requirements. Medium position is best for most lawns.

- To change cutting height, pull up on adjuster lever, move wheel up or down to suit your requirements and release adjuster lever. Be sure all wheels are in the same setting.
- NOTE:** Adjuster is properly positioned when lever inserts into hole in plate.

LEVER BACKWARD TO LOWER MOWER

LEVER FORWARD TO RAISE MOWER

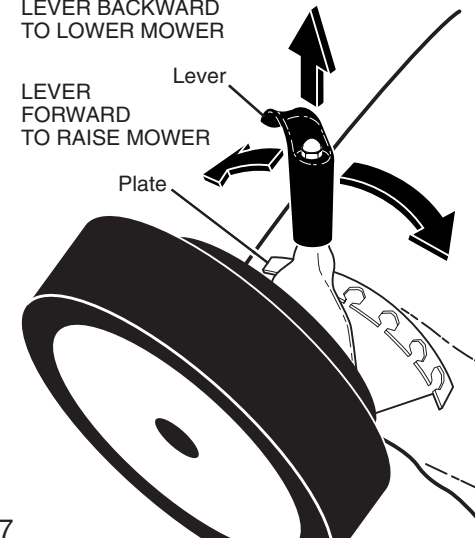

## TO CONVERT MOWER

Your lawn mower was shipped ready to be used as a mulcher. To convert to bagging or discharging:

### REAR BAGGING

- Lift rear door of the lawn mower and place the grass catcher frame hooks onto the grass bag brackets.
- To convert to mulching or discharging operation, remove grass catcher and close rear door.

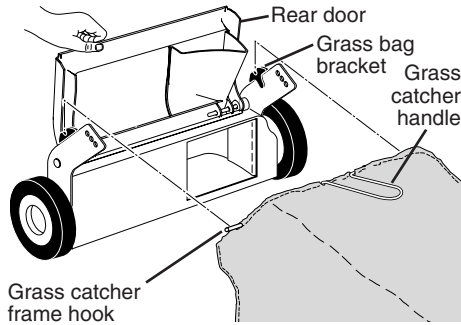

**NOTE:** Rear door will remain open until operator presence control bar is held down to the handle.

**CAUTION:** Do NOT force rear door to close. Serious damage to your mower could result.



### SIDE DISCHARGING

- Rear door must be closed.
- Open mulcher door and install discharge deflector under door as shown.
- Mower is now ready for discharging operation.
- To convert to mulching or bagging operation, discharge deflector must be removed and mulcher door must be closed and locked.

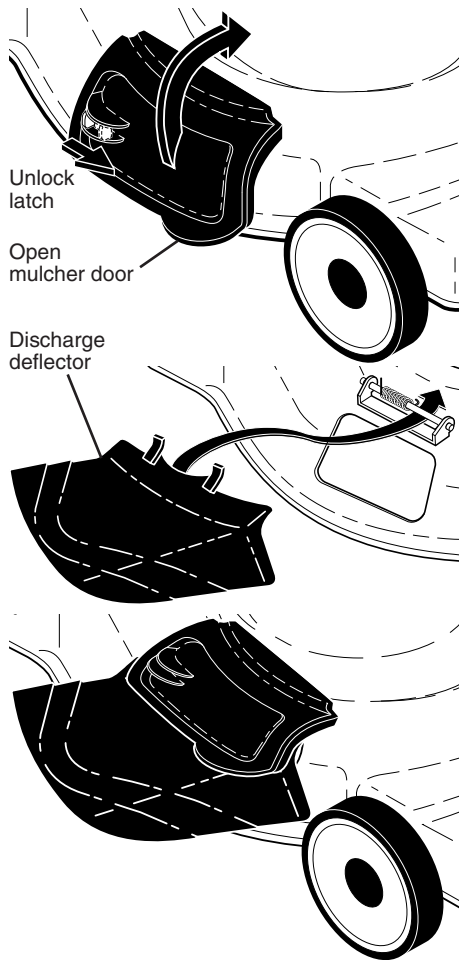

### SIMPLE STEPS TO REMEMBER WHEN CONVERTING YOUR LAWN MOWER

#### FOR MULCHING -

1. Rear door closed.
2. Mulcher door closed and locked.

#### FOR REAR BAGGING -

1. Grass catcher installed.
2. Mulcher door closed and locked.

#### FOR SIDE DISCHARGING -

1. Rear door closed.
2. Discharge deflector installed.

**CAUTION:** Do not run your lawn mower without rear door closed or approved grass catcher in place. Never attempt to operate the lawn mower with the rear door removed or propped open.

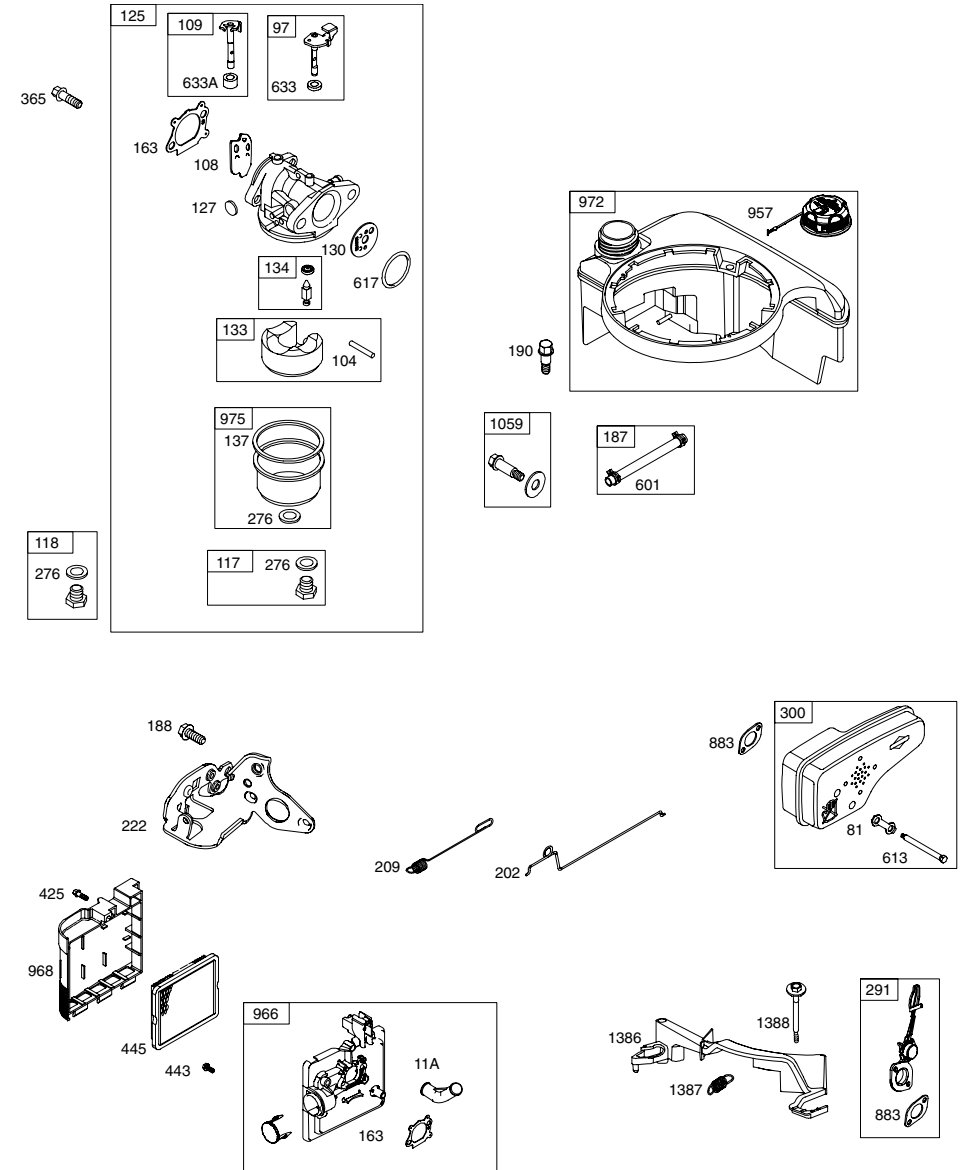



- 48 SHORT BLOCK
- 1058 OPERATOR'S MANUAL
- 1329 REPLACEMENT ENGINE
- 1330 REPAIR MANUAL

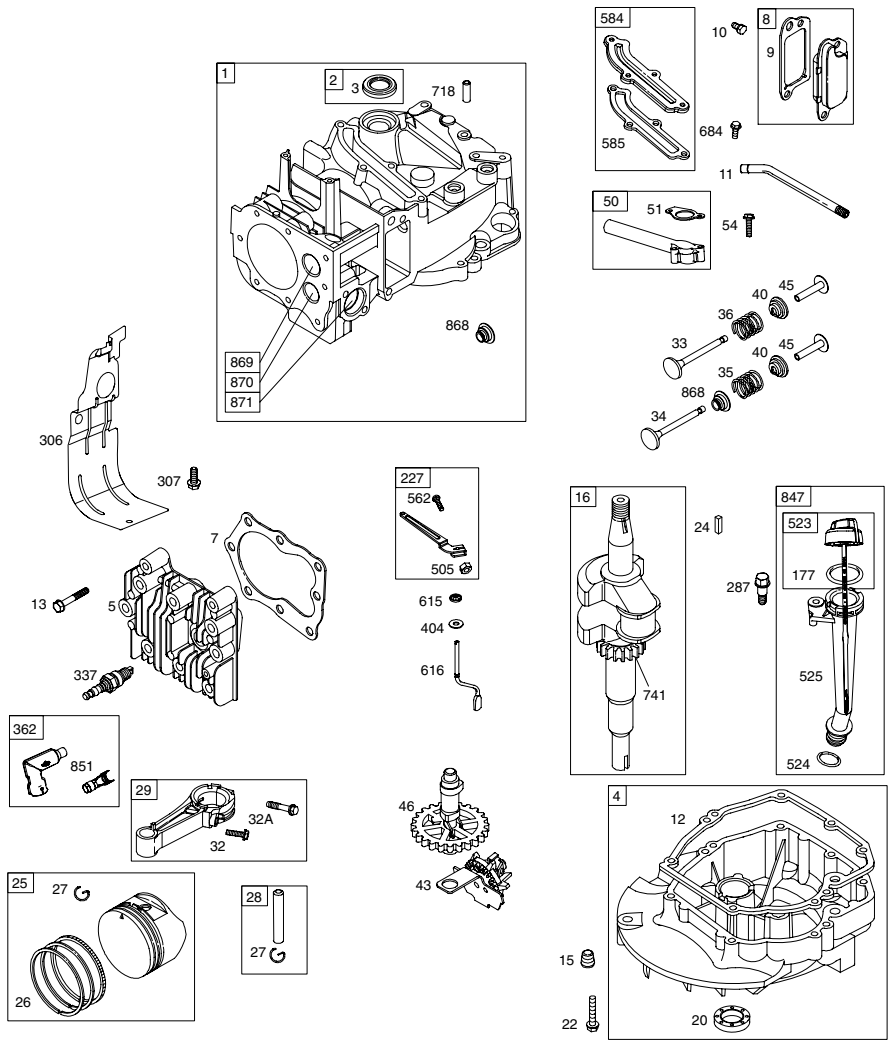

**TO EMPTY GRASS CATCHER**

1. Lift up on grass catcher using the frame handle.
2. Remove grass catcher with clippings from under lawn mower handle.
3. Empty clippings from bag using both frame handle and bag handle.

**NOTE:** Do not drag the bag when emptying; it will cause unnecessary wear.

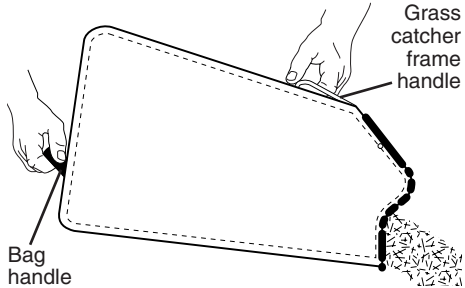

**BEFORE STARTING ENGINE**

**ADD OIL**

Your lawnmower is shipped without oil in the engine. For type and grade of oil to use, see "ENGINE" in the Maintenance section of this manual.

**CAUTION:** DO NOT overfill engine with oil, or it will smoke heavily from the muffler on startup.

1. Be sure lawnmower is level.
2. Remove oil dipstick from oil fill spout.
3. You receive a container of oil with the unit. Slowly pour the entire container down the oil fill spout into the engine.

**NOTE:** Initial oil fill requires only 18 oz. due to residual oil in engine from the manufacturers 100% quality testing. When changing oil you may need 20 oz.

4. Insert and tighten dipstick.

**IMPORTANT:**

- Check oil level before each use. Add oil if needed. Fill to full line on dipstick.
- Change the oil after every 25 hours of operation or each season. You may need to change the oil more often under dusty, dirty conditions. See "TO CHANGE ENGINE OIL" in the Maintenance section of this manual.

**ATTACH FUEL CAP CARTRIDGE**

Your mower is equipped with a special *FRESH START™* fuel cap and continuous fuel preserver cartridge. See the information and instructions packed with the *FRESH START™* cartridge.

1. Snap cartridge into bottom of fuel cap.
- NOTE:** Do not remove the silver foil seal on the side of cartridge that snaps into fuel cap.

2. Grasp the white peel tab and pull to remove the entire seal.
3. Screw fuel cap onto fuel tank after filling tank with gasoline.

Replace cartridge when empty (about once a season). Check preserver level visually.

**DANGER:** Cartridge fluid is HARMFUL OR FATAL IF SWALLOWED. Avoid contact to eyes, skin, or clothing. Do not take internally. Do not inhale fluid vapor. Keep out of reach of children. If swallowed, call a physician immediately.

**ADD GASOLINE**

- Fill fuel tank to bottom of tank filler neck. Do not overfill. Use fresh, clean, regular unleaded gasoline with a minimum of 87 octane. Do not mix oil with gasoline. Purchase fuel in quantities that can be used within 30 days to assure fuel freshness.

**CAUTION:** Wipe off any spilled oil or fuel. Do not store, spill or use gasoline near an open flame.

**CAUTION:** Alcohol blended fuels (called gasohol or using ethanol or methanol) can attract moisture which leads to separation and formation of acids during storage. Acidic gas can damage the fuel system of an engine while in storage. To avoid engine problems, the fuel system should be emptied before storage of 30 days or longer. Empty the gas tank, start the engine and let it run until the fuel lines and carburetor are empty. Use fresh fuel next season. See Storage Instructions for additional information. Never use engine or carburetor cleaner products in the fuel tank or permanent damage may occur.

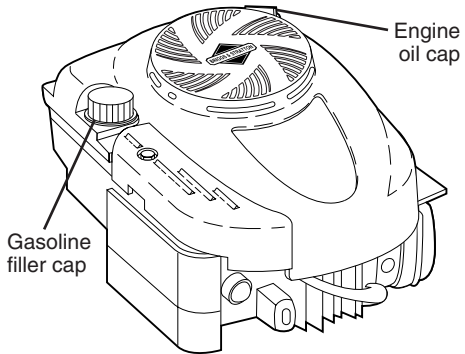

**TO STOP ENGINE**

- To stop engine, release operator presence control bar.

## TO START ENGINE

**NOTE:** Due to protective coatings on the engine, a small amount of smoke may be present during the initial use of the product and should be considered normal.

**NOTE:** Your engine is equipped with an automatic choke system. No priming or choking is required before starting.

- To start engine, hold operator presence control bar down to the handle and pull starter handle quickly. Do not allow starter rope to snap back.

## MOWING TIPS

**⚠ CAUTION:** Do not use de-thatcher blade attachments on your mower. Such attachments are hazardous, will damage your mower and could void your warranty.

- Under certain conditions, such as very tall grass, it may be necessary to raise the height of cut to reduce pushing effort and to keep from overloading the engine and leaving clumps of grass clippings. It may also be necessary to reduce ground speed and/or run the lawn mower over the area a second time.
- For extremely heavy cutting, reduce the width of cut by overlapping previously cut path and mow slowly.
- For better grass bagging and most cutting conditions, the engine speed should be set in the FAST position.
- Pores in cloth grass catchers can become filled with dirt and dust with use and catchers will collect less grass. To prevent this, regularly hose catcher off with water and let dry before using.
- Keep top of engine around starter clear and clean of grass clippings and chaff. This will help engine air flow and extend engine life.

## MULCHING MOWING TIPS

**IMPORTANT:** For best performance, keep mower housing free of built-up grass and trash. See "CLEANING" in the Maintenance section of this manual.

- The special mulching blade will recut the grass clippings many times and reduce them in size so that as they fall onto the lawn they will disperse into the grass and not be noticed. Also, the mulched grass will biodegrade quickly to provide nutrients for the lawn. Always mulch with your highest engine (blade) speed as this will provide the best recutting action of the blades.
- Avoid cutting your lawn when it is wet. Wet grass tends to form clumps and interferes with the mulching action. The best time to mow your lawn is the early afternoon. At this time the grass has dried, yet the newly cut area will not be exposed to direct sunlight.
- For best results, adjust the lawn mower cutting height so that the lawn mower cuts off only the top one-third of the grass blades. If the lawn is overgrown it will be necessary to raise the height of cut to reduce pushing effort and to keep from overloading the engine and leaving clumps of mulched grass. For extremely heavy grass, reduce your width of cut by overlapping previously cut path and mow slowly.
- Certain types of grass and grass conditions may require that an area be mulched a second time to completely hide the clippings. When doing a second cut, mow across (perpendicular) to the first cut path.
- Change your cutting pattern from week to week. Mow north to south one week then change to east to west the next week. This will help prevent matting and graining of the lawn.

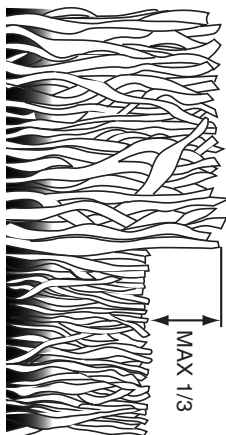

## CRAFTSMAN ROTARY LAWN MOWER - - MODEL NUMBER 944.369610

KEY NO.	PART NO.	DESCRIPTION	KEY NO.	PART NO.	DESCRIPTION
1	428156	Drive Control Assembly (Includes Cable)	27	175262	Screw, Pan Head #10-24 x 2-3/4
2	428234	Cover, Top	28	428165	Drive Cover
3	420378	Cam	29	409148	Locknut, Hex
4	420380X615	Lever, Drive Control, RH	32	194018	Drive Pulley
5	420381	Spring, Return	33	426609	V-Belt
6	181698	Screw	35	424524	Kit, Wheel Adjuster, Front, LH (Includes Red Knob and Pushnut)
7	420377X428	Cover, Bottom	36	424657	Gear Case Assembly, Complete
8	178848	Screw #10-16 x 5/8	38	191730	Locknut, Hex 1/4-20
9	427426	Cable, Drive	40	406558	Spring
10	420379X615	Lever, Drive Control, LH	41	424522	Kit, Wheel Adjuster, Front, RH (Includes Red Knob and Pushnut)
11	194231X460	Wheel & Tire Assembly, Front	54	427265	Grassbag
12	12000058	E-Ring	57	419951	Frame, Grassbag
13	403849	Pinion	80	421114	Kit, Water Washout Assembly (Includes Key Numbers 81 thru 83)
14	189403	Dust Cover	81	419735	Fitting, Water Washout
15	404845	Pawl, Drive	82	415585	Washer, Lock, Internal Tooth
16	67725	Washer, Flat 3/8	83	415586	Locknut, Hex, with O-Ring
25	404843X004	Belt Guide Bracket			
26	163409	Screw, Hi-Lo Thread #12 x 5/8			

**NOTE:** All component dimensions given in U.S. inches. 1 inch = 25.4 mm.

**IMPORTANT:** Use only Original Equipment Manufacturer (O.E.M.) replacement parts. Failure to do so could be hazardous, damage your lawn mower and void your warranty.

# CRAFTSMAN ROTARY LAWN MOWER -- MODEL NUMBER 944.369610

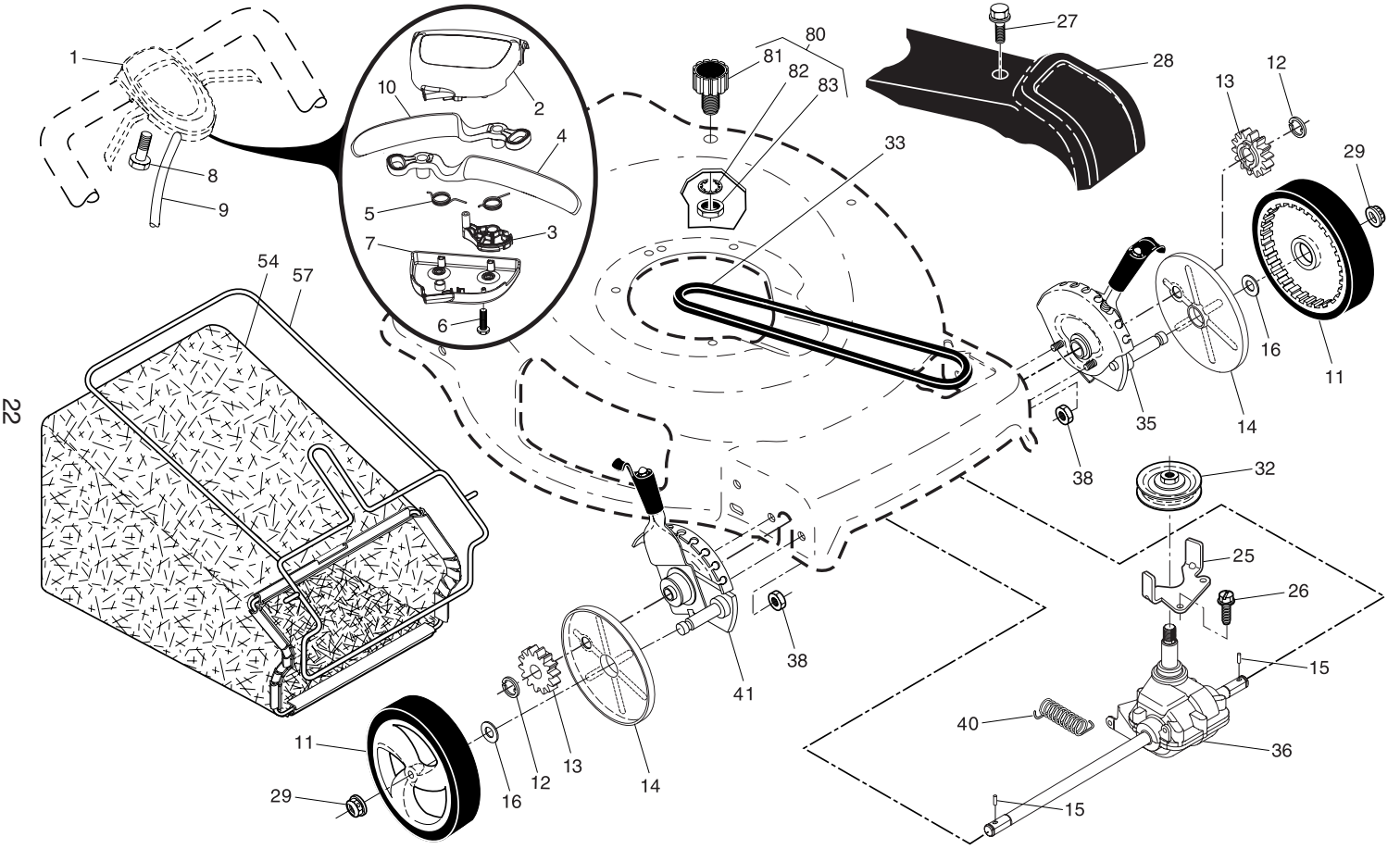

## MAINTENANCE

MAINTENANCE SCHEDULE	MAINTENANCE				BEFORE STORAGE
	BEFORE EACH USE	AFTER EACH USE	EVERY 10 HOURS	EVERY 25 HOURS OR SEASON	
Check for Loose Fasteners	✓				✓
Clean / Inspect Grass Catcher *	✓	✓			
Check Tires	✓				
Check Drive Wheels ***		✓			
Clean Lawn Mower ****			✓		
Clean under Drive Cover ****				✓	
Check Drive Belt / Pulleys ***				✓	
Check / Sharpen / Replace Blade				✓	
Lubrication				✓	
Clean and Recharge Battery **				✓	✓
Check Engine Oil level			✓		
Change Engine Oil				✓	
Clean Air Filter				✓	
Inspect Muffler				✓	
Replace Spark Plug				✓	
Replace Air Filter Paper Cartridge				✓	
Empty fuel system or add Stabilizer					✓

- \* (if so equipped)  
 \*\* Electric-Start mowers  
 \*\*\* Power-Propelled mowers  
 \*\*\*\* Use a scraper to clean under deck
- 1 - Change more often if operating under a heavy load or in high outdoor temperatures.
  - 2 - Service more often if operating in dirty or dusty conditions.
  - 3 - Replace blades more often when mowing in sandy soil.
  - 4 - Change 48 hours at end of season.
  - 5 - And after each 5 hours of use.

### GENERAL RECOMMENDATIONS

The warranty on this lawn mower does not cover items that have been subjected to operator abuse or negligence. To receive full value from the warranty, operator must maintain unit as instructed in this manual. Some adjustments will need to be made periodically to properly maintain your unit. At least once a season, check to see if you should make any of the adjustments described in the Service and Adjustments section of this manual.

- At least once a year, replace the spark plug, clean or replace air filter element and check blade for wear. A new spark plug and clean/new air filter element assure proper air-fuel mixture and help your engine run better and last longer.
- Follow the maintenance schedule in this manual.

### BEFORE EACH USE

- Check engine oil level.
- Check for loose fasteners.

### LUBRICATION

Keep unit well lubricated (See "LUBRICATION CHART").

### LUBRICATION CHART

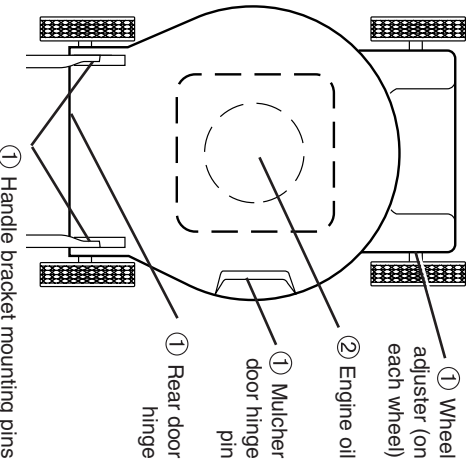

- 1 Spray lubricant
- 2 See "ENGINE" in Maintenance section.

**IMPORTANT:** Do not oil or grease plastic wheel bearings. Viscous lubricants will attract dust and dirt that will shorten the life of the self-lubricating bearings. If you feel they must be lubricated, use only dry, powdered graphite type lubricant sparingly.



## LAWN MOWER

Always observe safety rules when performing any maintenance.

### TIRES

- Keep tires free of gasoline, oil, or insect control chemicals which can harm rubber.
- Avoid stumps, stones, deep ruts, sharp objects and other hazards that may cause tire damage.

### DRIVE WHEELS

Check rear drive wheels each time before you mow to be sure they move freely. The wheels not turning freely means trash, grass cuttings, etc. are in the drive wheel area and must be cleaned to free drive wheels. If necessary to clean the drive wheels, be sure to clean both rear wheels.

### BLADE CARE

For best results, mower blade must be kept sharp. Replace a bent or damaged blade.

**CAUTION:** Use only a replacement blade approved by the manufacturer of your mower. Using a blade not approved by the manufacturer of your mower is hazardous, could damage your mower and void your warranty.

#### TO REMOVE BLADE

1. Disconnect spark plug wire from spark plug and place wire where it cannot come in contact with plug.
  2. Turn lawn mower on its side. Make sure air filter and carburetor are up.
  3. Use a wood block between blade and mower housing to prevent blade from turning when removing blade bolt.
- NOTE:** Protect your hands with gloves and/or wrap blade with heavy cloth.
4. Remove blade bolt by turning counter-clockwise.
  5. Remove blade and attaching hardware (bolt, lock washer and hardened washer).

**NOTE:** Remove the blade adapter and check the key inside hub of blade adapter. The key must be in good condition to work properly. Replace adapter if damaged.

#### TO REPLACE BLADE

1. Position the blade adapter on the engine crankshaft. Be sure key in adapter and crankshaft keyway are aligned.
  2. Position blade on the blade adapter.
- IMPORTANT:** To ensure proper assembly, center hole in blade must align with star on blade adapter.

3. Be sure the trailing edge of blade (opposite sharp edge) is up toward the engine.
4. Install the blade bolt with the lock washer and hardened washer into blade adapter and crankshaft.

5. Use block of wood between blade and lawn mower housing and tighten the blade bolt, turning clockwise.
- The recommended tightening torque is 35-40 ft. lbs.

**IMPORTANT:** Blade bolt is heat treated. If bolt needs replacing, replace only with approved bolt shown in the Repair Parts section of this manual.

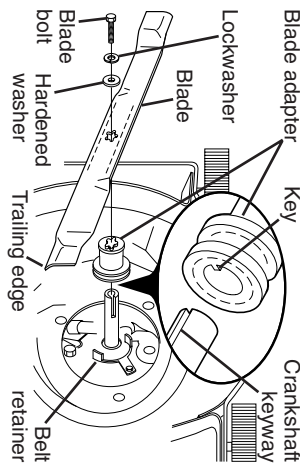

#### TO SHARPEN BLADE

**NOTE:** We do not recommend sharpening blade - but if you do, be sure the blade is balanced. An unbalanced blade will cause eventual damage to lawn mower or engine.

- The blade can be sharpened with a file or on a grinding wheel. Do not attempt to sharpen while on the mower.
- To check blade balance, you will need a 5/8" diameter steel bolt, pin, or a cone balancer. (When using a cone balancer, follow the instructions supplied with balancer.)

**NOTE:** Do not use a nail for balancing blade. The lobes of the center hole may appear to be centered, but are not.

- Slide blade on to an unthreaded portion of the steel bolt or pin and hold the bolt or pin parallel with the ground. If blade is balanced, it should remain in a horizontal position. If either end of the blade moves downward, sharpen the heavy end until the blade is balanced.

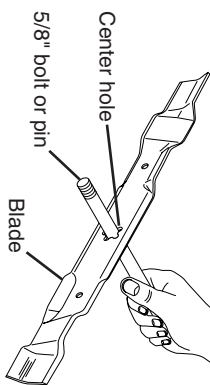

## CRAFTSMAN ROTARY LAWN MOWER - - MODEL NUMBER 944.369610

KEY NO.	PART NO.	DESCRIPTION	KEY NO.	PART NO.	DESCRIPTION	KEY NO.	PART NO.	DESCRIPTION
1	427616X479	Upper Handle	28	72250505	Bolt, Carriage 5/16-18 x 5/8	51	419943	Front Baffle
2	425076	Cable, Engine Zone Control / Rear Door Prop	32	419944	Latch, Mulcher Door	52	404763	Decal, Danger
3	86899X004	Bracket, Upstop	33	423358	Mulcher Door	53	17060408	Screw, Semi-Gimlett Point 1/4-20 x 1/2
4	145006	Guide, Cable	34	419946X615	Bracket, Grassbag	55	191730	Nut, Hex
5	66426	Wire Tie	35	427456	Kit, Wheel Adjuster, Rear, RH (Includes Red Knob & Pushnut)	56	17411312	Screw, Hex Washer Head #13 x 3/4
6	189713X428	Handle Knob	36	175735	Hinge Bracket Assembly	57	155377	Nut, Hex
7	750634	Screw #10-24 x 1/2	37	17000512	Screw, Flanged, Thread Cutting 5/16-18 x 3/4	58	421241X479	Lower Handle
8	427611X428	Control Bar	38	419942X428	Discharge Deflector	59	191574	Handle Bolt
9	424207	Rear Door Assembly	39	419033X479	Handle Bracket, LH	61	73930500	Nut, Hex 3/8-16
10	19131610	Washer	40	419031X479	Handle Bracket, RH	62	420474X004	Belt Retainer
11	425575	Hairpin, Door/Handle Pivot	41	150406	Bolt, Engine 3/8-16	63	178848	Screw #10-16 x 5/8
17	427120X428	Rear Baffle	42	193000	Spring, Torsion	64	- - -	Engine, Briggs & Stratton, Model Number 126T02-0372-B1 (See Breakdown)
18	132004	Keps Locknut 1/4-20	43	191730	Nut, Hex, Nylon	68	427457	Kit, Wheel Adjuster, Rear, LH (Includes Red Knob and Pushnut)
19	194788	Rope Guide	44	424995	Kit, Lawn Mower Housing	- -	427275	Owner's Manual, English
20	423323	Rear Skirt	45	175650	Rod, Hinge	- -	427276	Owner's Manual, French
21	419949	Spring, Rear Door, LH, Black	46	421782	Blade Adapter / Pulley			
22	141841	Screw, Panhead, Torx #20	47	421825	Blade, 22"			
24	419948	Spring, Rear Door, RH, Grey	48	851074	Washer, Hardened			
25	409148	Locknut, Hex	49	850263	Washer, Helical			
26	419945	Screw, Rear Door/Handle Pivot	50	851084	Screw, Machine, Hex Head 3/8-24 x 1-3/8 Grade 8			
27	400246X460	Wheel & Tire Assembly, Rear						

**NOTE:** All component dimensions given in U.S. inches. 1 inch = 25.4 mm.

**IMPORTANT:** Use only Original Equipment Manufacturer (O.E.M.) replacement parts. Failure to do so could be hazardous, damage your lawn mower and void your warranty.



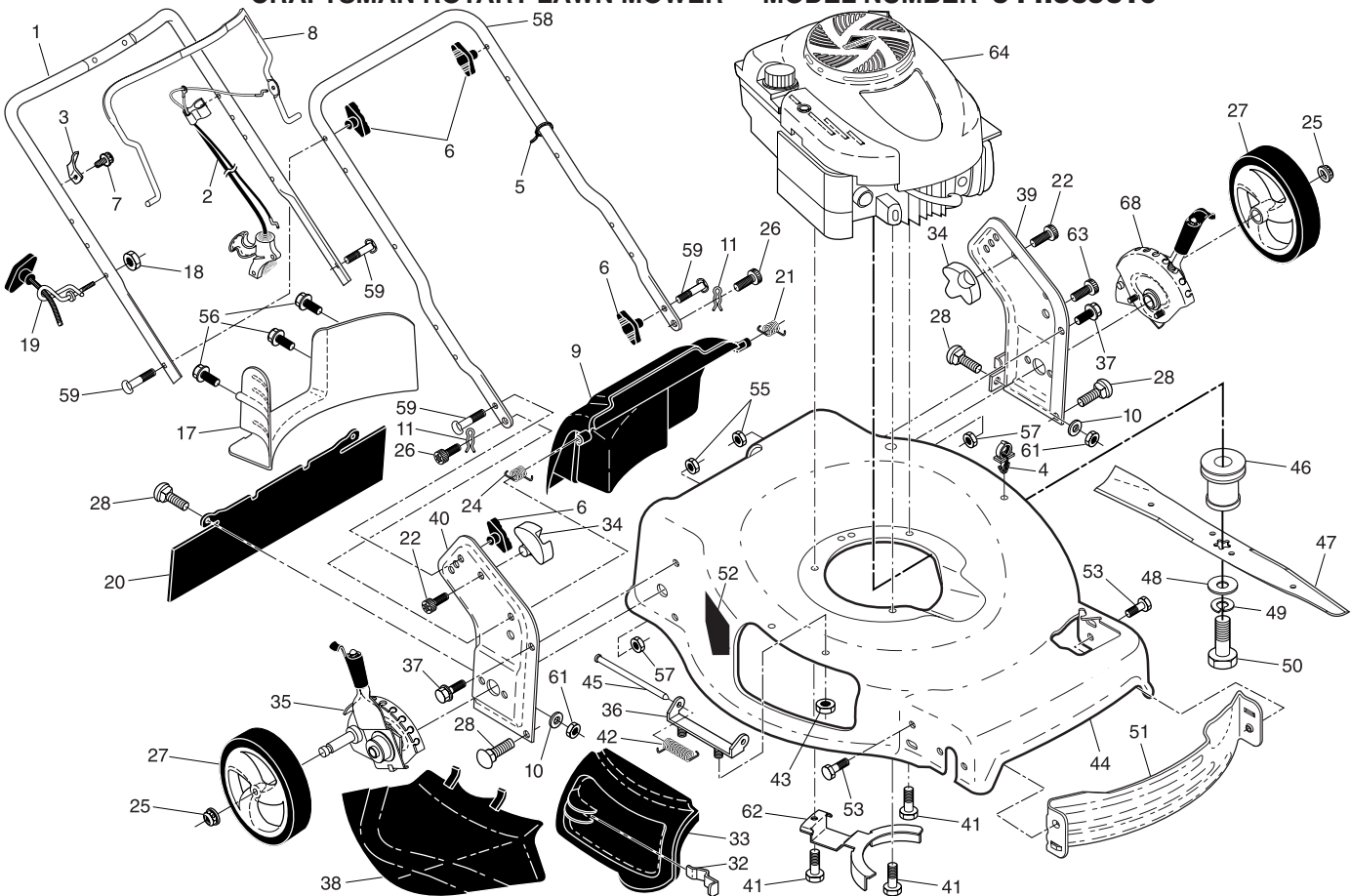

**GRASS CATCHER**

- The grass catcher may be hosed with water, but must be dry when used.
- Check your grass catcher often for damage or deterioration. Through normal use it will wear. If catcher needs replacing, replace only with approved replacement catcher shown in the Repair Parts section of this manual. Give the lawn mower model number when ordering.

**GEAR CASE**

- To keep your drive system working properly, the gear case and area around the drive should be kept clean and free of trash build-up. Clean under the drive cover twice a season.
- The gear case is filled with lubricant to the proper level at the factory. The only time the lubricant needs attention is if service has been performed on the gear case.
- If lubricant is required, use only Texaco Saplax Premium 1 Grease, Part No. 750369. Do not substitute.

**ENGINE**

**LUBRICATION**

Use only high quality detergent oil rated with API service classification SG-SL. Select the oil's SAE viscosity grade according to your expected operating temperature.

SAE VISCOSITY GRADES	
SW-30	SAE 30
TEMPERATURE RANGE ANTICIPATED BEFORE NEXT OIL CHANGE	
F -20 0 30 32 40 60 80 100	C -30 -20 -10 0 10 20 30 40

**NOTE:** Although multi-viscosity oils (5W30, 10W30 etc.) improve starting in cold weather, these multi-viscosity oils will result in increased oil consumption when used above 32°F. Check your engine oil level more frequently to avoid possible engine damage from running low on oil. Change the oil after every 25 hours of operation or at least once a year if the lawn mower is not used for 25 hours in one year.

Check the crankcase oil level before starting the engine and after each five (5) hours of continuous use. Tighten oil plug securely each time you check the oil level.

**TO CHANGE ENGINE OIL**

- NOTE:** Before tipping lawn mower to drain oil, empty fuel tank by running engine until fuel tank is empty.
1. Disconnect spark plug wire from spark plug and place wire where it cannot come in contact with plug.
  2. Remove engine oil cap; lay aside on a clean surface.
  3. Tip lawn mower on its side as shown and drain oil into a suitable container. Rock lawn mower back and forth to remove any oil trapped inside of engine.

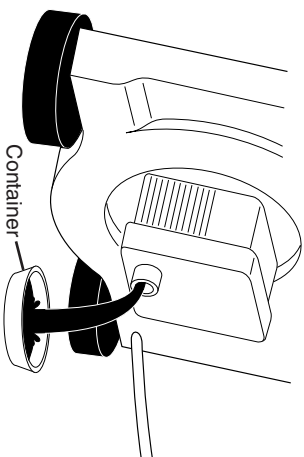

4. Wipe off any spilled oil from lawn mower or side of engine.
5. Slowly pour oil down the oil fill spout, stopping every few ounces to check the oil level with the dipstick.
6. Stop adding oil when you reach the FULL mark on the dipstick. Wait a minute to allow oil to settle.
7. Continue adding small amounts of oil, rechecking the dipstick until oil level settles at FULL. DO NOT overfill, or engine will smoke heavily from the muffler on startup.
8. Always be sure to retighten oil dipstick before starting engine.
9. Reconnect spark plug wire to spark plug.

**AIR FILTER**

Your engine will not run properly and may be damaged by using a dirty air filter. Replace the air filter cartridge every 100 hours of operation or every season, whichever occurs first. Service air cleaner more often under dusty conditions.

**TO CLEAN AIR FILTER**

1. Loosen screw and tilt cover to remove.
2. Carefully remove cartridge.
3. Clean by gently tapping on a flat surface. If very dirty, replace cartridge.

**CAUTION:** Petroleum solvents, such as kerosene, are not to be used to clean cartridge. They may cause deterioration of the cartridge. Do not oil cartridge. Do not use pressurized air to clean or dry cartridge.

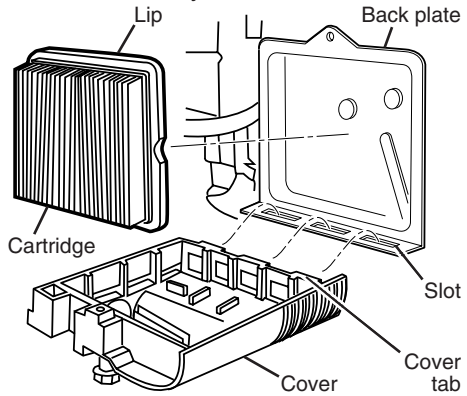

**MUFFLER**

Inspect and replace corroded muffler as it could create a fire hazard and/or damage.

**SPARK PLUG**

Replace spark plug at the beginning of each mowing season or after every 100 hours of operation, whichever occurs first. Spark plug type and gap setting are shown in the "PRODUCT SPECIFICATIONS" section of this manual.

**CLEANING**

**IMPORTANT:** For best performance, keep mower housing free of built-up grass and trash. Clean the underside of your mower after each use.

**CAUTION:** Disconnect spark plug wire from spark plug and place wire where it cannot come in contact with plug.

- Clean the underside of your lawn mower by scraping to remove build-up of grass and trash.
- Clean engine often to keep trash from accumulating. A clogged engine runs hotter and shortens engine life.
- Keep finished surfaces and wheels free of all gasoline, oil, etc.
- We do not recommend using a garden hose to clean lawn mower unless the electrical system, muffler, air filter and carburetor are covered to keep water out. Water in engine can result in shortened engine life.

**WATER WASHOUT FEATURE**

Your lawn mower is equipped with a fitting that allows quick and easy cleaning of the underside of the housing. To use this feature, proceed as follows:

1. Move lawn mower to an area of cut grass or another hard surface.

**NOTE:** Water, grass and other debris will drain from beneath the mower housing during the washout process.

2. Remove grass catcher and discharge chute assembly from lawn mower.
3. Close mulcher door (if equipped).
4. Connect a garden hose to the fitting where shown.

**IMPORTANT:** Be sure the garden hose is not routed under the lawn mower housing or entangled in the wheels.

5. Turn on water supply and check for leaks at the fitting.

If no leaks are present, start engine (as described in the Operation section of this manual) and let engine run until the underside of the lawn mower is clean.

**WARNING:** Do not engage the drive system during the washout process.

6. Shut off the engine.
7. Shut off water supply and remove hose from fitting.

**CAUTION:** Do not remove hose from fitting while engine is running. Water in engine can result in shortened engine life.

8. Start engine (as described in the Operation section of this manual) and let engine run for a full minute to remove excess water from mower.

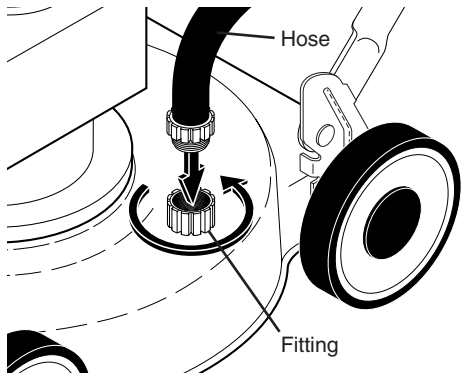

**CLEAN UNDER DRIVE COVER**

Clean under drive cover at least twice a season. Scrape underside of cover with putty knife or similar tool to remove any build-up of trash or grass on underside of drive cover.

**TROUBLESHOOTING - See appropriate section in manual unless directed to a Sears Parts & Repair Centre.**

PROBLEM	CAUSE	CORRECTION
<b>Poor cut – uneven</b>	<ol style="list-style-type: none"> <li>1. Worn, bent or loose blade.</li> <li>2. Wheel heights uneven.</li> <li>3. Buildup of grass, leaves and trash under mower.</li> </ol>	<ol style="list-style-type: none"> <li>1. Replace blade. Tighten blade bolt.</li> <li>2. Set all wheels at same height.</li> <li>3. Clean underside of mower housing.</li> </ol>
<b>Excessive vibration</b>	<ol style="list-style-type: none"> <li>1. Worn, bent or loose blade.</li> <li>2. Bent engine crankshaft.</li> </ol>	<ol style="list-style-type: none"> <li>1. Replace blade. Tighten blade bolt.</li> <li>2. Contact a Sears or other qualified service centre.</li> </ol>
<b>Starter rope hard to pull</b>	<ol style="list-style-type: none"> <li>1. Engine flywheel brake is on when control bar is released.</li> <li>2. Bent engine crankshaft.</li> <li>3. Blade adapter broken.</li> <li>4. Blade dragging in grass.</li> </ol>	<ol style="list-style-type: none"> <li>1. Depress control bar to upper handle before pulling starter rope.</li> <li>2. Contact a Sears or other qualified service centre.</li> <li>3. Replace blade adapter.</li> <li>4. Move lawn mower to cut grass or to hard surface.</li> </ol>
<b>Grass catcher not filling (If so equipped)</b>	<ol style="list-style-type: none"> <li>1. Cutting height too low.</li> <li>2. Lift on blade worn off.</li> <li>3. Catcher not venting air.</li> </ol>	<ol style="list-style-type: none"> <li>1. Raise cutting height.</li> <li>2. Replace blade.</li> <li>3. Clean grass catcher.</li> </ol>
<b>Hard to push</b>	<ol style="list-style-type: none"> <li>1. Grass is too high or wheel height is too low.</li> <li>2. Rear of lawn mower housing or cutting blade dragging in grass.</li> <li>3. Grass catcher too full.</li> <li>4. Handle height position not right for you.</li> </ol>	<ol style="list-style-type: none"> <li>1. Raise cutting height.</li> <li>2. Raise rear of lawn mower housing one (1) setting higher.</li> <li>3. Empty grass catcher.</li> <li>4. Adjust handle height to suit.</li> </ol>
<b>Loss of drive or slowing of drive speed</b>	<ol style="list-style-type: none"> <li>1. Belt wear.</li> <li>2. Belt off of pulley.</li> <li>3. Drive cable worn or broken.</li> <li>4. "Loose" drive control system.</li> </ol>	<ol style="list-style-type: none"> <li>1. Check/replace drive belt.</li> <li>2. Check/reinstall drive belt.</li> <li>3. Replace drive cable.</li> <li>4. Adjust drive control.</li> </ol>

**TROUBLESHOOTING - See appropriate section in manual unless directed to a Sears Parts & Repair Centre.**

PROBLEM	CAUSE	CORRECTION
<b>Does not start</b>	<ol style="list-style-type: none"> <li>1. Dirty air filter.</li> <li>2. Out of fuel.</li> <li>3. Stale fuel.</li> <li>4. Water in fuel.</li> <li>5. Spark plug wire is disconnected.</li> <li>6. Bad spark plug.</li> <li>7. Loose blade or broken blade adapter.</li> <li>8. Control bar in released position.</li> <li>9. Control bar defective.</li> <li>10. Fuel valve lever (if so equipped) in OFF position.</li> <li>11. Weak battery (if equipped).</li> <li>12. Disconnected battery connector (if equipped).</li> <li>13. Blown fuse (if equipped).</li> </ol>	<ol style="list-style-type: none"> <li>1. Clean/replace air filter.</li> <li>2. Fill fuel tank.</li> <li>3. Empty fuel tank and refill tank with fresh, clean gasoline.</li> <li>4. Empty fuel tank and refill tank with fresh, clean gasoline.</li> <li>5. Connect wire to plug.</li> <li>6. Replace spark plug.</li> <li>7. Tighten blade bolt or replace blade adapter.</li> <li>8. Depress control bar to handle.</li> <li>9. Replace control bar.</li> <li>10. Turn fuel valve lever to the ON position.</li> <li>11. Charge battery.</li> <li>12. Connect battery to engine.</li> <li>13. Replace fuse.</li> </ol>
<b>Loss of power</b>	<ol style="list-style-type: none"> <li>1. Rear of lawn mower housing or cutting blade dragging in heavy grass.</li> <li>2. Cutting too much grass.</li> <li>3. Dirty air filter.</li> <li>4. Buildup of grass, leaves, and trash under mower.</li> <li>5. Too much oil in engine.</li> <li>6. Walking speed too fast.</li> </ol>	<ol style="list-style-type: none"> <li>1. Raise cutting height.</li> <li>2. Raise cutting height.</li> <li>3. Clean/replace air filter.</li> <li>4. Clean underside of mower housing.</li> <li>5. Check oil level.</li> <li>6. Cut at slower walking speed.</li> </ol>

**SERVICE AND ADJUSTMENTS**

- ⚠ WARNING:** To avoid serious injury, before performing any service and adjustments:
1. Release control bar and stop engine.
  2. Make sure the blade and all moving parts have completely stopped.
  3. Disconnect spark plug wire from spark plug and place wire where it cannot come in contact with plug.

**LAWN MOWER  
TO ADJUST CUTTING HEIGHT**

See "TO ADJUST CUTTING HEIGHT" in the Operation section of this manual.

**REAR DEFLECTOR**

The rear deflector, attached between the rear wheels of your mower, is provided to minimize the possibility that objects will be thrown out of the rear of the mower into the operator mowing position. If the deflector becomes damaged, it should be replaced.

**TO REMOVE DRIVE BELT**

1. Remove drive cover and belt keeper.
2. Remove belt from gearcase pulley.
3. Turn lawn mower on its side with air filter and carburetor down.
4. Remove blade and blade adapter.
5. Remove belt from engine pulley.

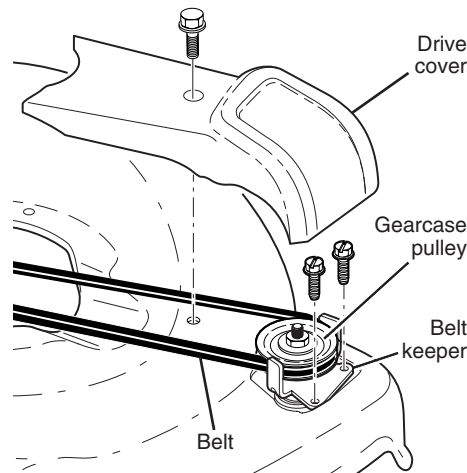

**TO REPLACE DRIVE BELT**

1. Place new drive belt on engine pulley, inside tabs of belt retainer.
2. Route the other end of the new drive belt through hole in housing.
3. Reinstall blade adapter and blade.
4. Return mower to upright position.
5. Install new belt on gearcase pulley.

6. Reinstall belt keeper and drive cover.
- NOTE:** Always use factory approved belt to assure proper fit and long life.

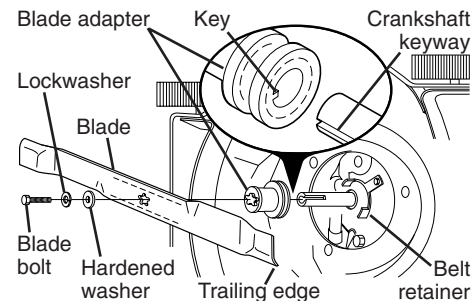

**TO ADJUST HANDLE**

Your handle has three (3) height positions - adjust to a height that suits you.

1. Remove knob and carriage bolt on one side of the lower handle.
2. While holding handle assembly, remove knob and carriage bolt from opposite side, align hole in handle with desired hole in handle bracket and reassemble bolt and knob and tighten securely.
3. Align opposite side of handle with same positioning hole and secure with bolt and knob.

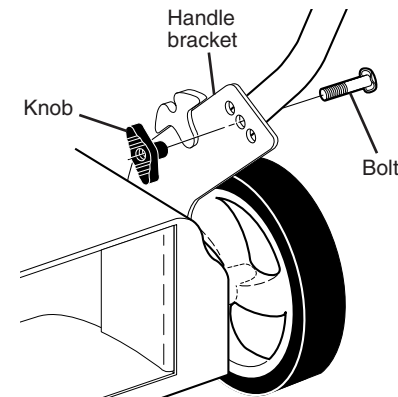

## ENGINE

### ENGINE SPEED

Your engine speed has been factory set. Do not attempt to increase engine speed or it may result in personal injury. If you believe that engine is running too fast or too slow, take your mower to a Sears or other qualified service center for repair and adjustment.

### CARBURETOR

Your carburetor is not adjustable. If your engine does not operate properly due

to suspected carburetor problems, take your lawn mower to a Sears or other qualified service center for repair and/or adjustment.

**IMPORTANT:** Never tamper with the engine governor, which is factory set for proper engine speed. Overspeeding the engine above the factory high speed setting can be dangerous. If you think the engine-governed high speed needs adjusting, contact a Sears or other qualified service center, which has proper equipment and experience to make any necessary adjustments.

## STORAGE

Immediately prepare your lawn mower for storage at the end of the season or if the unit will not be used for 30 days or more.

### LAWN MOWER

When lawn mower is to be stored for a period of time, clean it thoroughly, remove all dirt, grease, leaves, etc. Store in a clean, dry area.

1. Clean entire lawn mower (See "CLEANING" in the Maintenance section of this manual).
2. Lubricate as shown in the Maintenance section of this manual.
3. Be sure that all nuts, bolts, screws, and pins are securely fastened. Inspect moving parts for damage, breakage and wear. Replace if necessary.
4. Touch up all rusted or chipped paint surfaces; sand lightly before painting.

### HANDLE

You can fold your handle for storage.

1. Loosen the two (2) handle knobs on sides of the upper handle and allow handle to fold down to the rear.
  2. Remove the two (2) handle knobs and carriage bolts on sides of the lower handle and pivot entire handle assembly forward and allow it to rest on mower.
  3. Reinstall knobs and carriage bolts to lower handle / handle brackets for safe keeping.
- When setting up your handle from the storage position, lower handle will require manually locking into mowing position.

**IMPORTANT:** When folding the handle for storage or transportation, be sure to fold the handle as shown or you may damage the control cables.

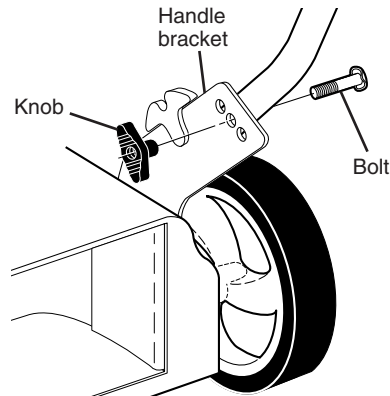
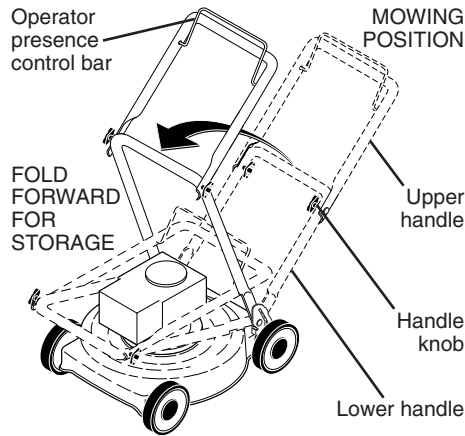

## ENGINE

### FUEL SYSTEM

**IMPORTANT:** It is important to prevent gum deposits from forming in essential fuel system parts such as carburetor, fuel filter, fuel hose, or tank during storage. Alcohol blended fuels (called gasohol or using ethanol or methanol) can attract moisture which leads to separation and formation of acids during storage. Acidic gas can damage the fuel system of an engine while in storage.

- Empty the fuel tank by starting the engine and letting it run until the fuel lines and carburetor are empty.
- Never use engine or carburetor cleaner products in the fuel tank or permanent damage may occur.
- Use fresh fuel next season.

**NOTE:** Fuel stabilizer is an acceptable alternative in minimizing the formation of fuel gum deposits during storage. Add stabilizer to gasoline in fuel tank or storage container. Always follow the mix ratio found on stabilizer container. Run engine at least 10 minutes after adding stabilizer to allow the stabilizer to reach the carburetor. Do not empty the gas tank and carburetor if using fuel stabilizer.

**NOTE:** FRESH START™ fuel cap and cartridge system automatically drips concentrated fuel preserver into your fuel tank and is an acceptable alternative to adding fuel stabilizer.

## ENGINE OIL

Drain oil (with engine warm) and replace with clean engine oil. (See "ENGINE" in the Maintenance section of this manual).

### CYLINDER

1. Remove spark plug.
2. Pour one ounce (29 ml) of oil through spark plug hole into cylinder.
3. Pull starter handle slowly a few times to distribute oil.
4. Replace with new spark plug.

### OTHER

- Do not store gasoline from one season to another.
- Replace your gasoline can if your can starts to rust. Rust and/or dirt in your gasoline will cause problems.
- If possible, store your unit indoors and cover it to protect it from dust and dirt.
- Cover your unit with a suitable protective cover that does not retain moisture. Do not use plastic. Plastic cannot breathe, which allows condensation to form and will cause your unit to rust.

**IMPORTANT:** Never cover mower while engine and exhaust areas are still warm.

**CAUTION:** Never store the lawn mower with gasoline in the tank inside a building where fumes may reach an open flame or spark. Allow the engine to cool before storing in any enclosure.