

SEARS
OWNER'S
MANUAL

MODEL NO.
944.600090

Important:
Read and follow
all Safety Rules
and Instructions
Before Operating
This Equipment



CRAFTSMAN®

26.0 HP*
ELECTRIC START
54" MOWER
AUTOMATIC TRANSMISSION
GARDEN TRACTOR

- Assembly
- Operation
- Maintenance
- Service and Adjustments
- Repair Parts

434838 Rev. 1

*As rated by the engine manufacturer

Sears Canada, Inc., Toronto, Ontario M5B 2B8



SAFETY RULES



Safe Operation Practices for Ride-On Mowers

DANGER: THIS CUTTING MACHINE IS CAPABLE OF AMPUTATING HANDS AND FEET AND THROWING OBJECTS. FAILURE TO OBSERVE THE FOLLOWING SAFETY INSTRUCTIONS COULD RESULT IN SERIOUS INJURY OR DEATH.



WARNING: In order to prevent accidental starting when setting up, transporting, adjusting or making repairs, always disconnect spark plug wire and place wire where it cannot contact spark plug.



WARNING: Do not coast down a hill in neutral, you may lose control of the tractor.



WARNING: Tow only the attachments that are recommended by and comply with specifications of the manufacturer of your tractor. Use common sense when towing. Operate only at the lowest possible speed when on a slope. Too heavy of a load, while on a slope, is dangerous. Tires can lose traction with the ground and cause you to lose control of your tractor.

- Do not operate the machine while under the influence of alcohol or drugs.
- Watch for traffic when operating near or crossing roadways.
- Use extra care when loading or unloading the machine into a trailer or truck.
- Always wear eye protection when operating machine.
- Data indicates that operators, age 60 years and above, are involved in a large percentage of riding mower-related injuries. These operators should evaluate their ability to operate the riding mower safely enough to protect themselves and others from serious injury.
- Follow the manufacturer's recommendation for wheel weights or counterweights.
- Keep machine free of grass, leaves or other debris build-up which can touch hot exhaust / engine parts and burn. Do not allow the mower deck to plow leaves or other debris which can cause build-up to occur. Clean any oil or fuel spillage before operating or storing the machine. Allow machine to cool before storage.

I. GENERAL OPERATION

- Read, understand, and follow all instructions on the machine and in the manual before starting.
- Do not put hands or feet near rotating parts or under the machine. Keep clear of the discharge opening at all times.
- Only allow responsible adults, who are familiar with the instructions, to operate the machine.
- Clear the area of objects such as rocks, toys, wire, etc., which could be picked up and thrown by the blades.
- Be sure the area is clear of bystanders before operating. Stop machine if anyone enters the area.
- Never carry passengers.
- Do not mow in reverse unless absolutely necessary. Always look down and behind before and while backing.
- Never direct discharged material toward anyone. Avoid discharging material against a wall or obstruction. Material may ricochet back toward the operator. Stop the blades when crossing gravel surfaces.
- Do not operate machine without the entire grass catcher, discharge chute, or other safety devices in place and working.
- Slow down before turning.
- Never leave a running machine unattended. Always turn off blades, set parking brake, stop engine, and remove keys before dismounting.
- Disengage blades when not mowing. Shut off engine and wait for all parts to come to a complete stop before cleaning the machine, removing the grass catcher, or unclogging the discharge chute.
- Operate machine only in daylight or good artificial light.

II. SLOPE OPERATION

Slopes are a major factor related to loss of control and tip-over accidents, which can result in severe injury or death. Operation on all slopes requires extra caution. If you cannot back up the slope or if you feel uneasy on it, do not mow it.

- Mow up and down slopes, not across.
- Watch for holes, ruts, bumps, rocks, or other hidden objects. Uneven terrain could overturn the machine. Tall grass can hide obstacles.
- Choose a low ground speed so that you will not have to stop or shift while on the slope.
- Do not mow on wet grass. Tires may lose traction. Always keep the machine in gear when going down slopes. Do not shift to neutral and coast downhill.
- Avoid starting, stopping, or turning on a slope. If the tires lose traction, disengage the blades and proceed slowly straight down the slope.
- Keep all movement on the slopes slow and gradual. Do not make sudden changes in speed or direction, which could cause the machine to roll over.
- Use extra care while operating machine with grass catchers or other attachments; they can affect the stability of the machine. Do no use on steep slopes.
- Do not try to stabilize the machine by putting your foot on the ground.
- Do not mow near drop-offs, ditches, or embankments. The machine could suddenly roll over if a wheel is over the edge or if the edge caves in.



SAFETY RULES

Safe Operation Practices for Ride-On Mowers



III. CHILDREN

Tragic accidents can occur if the operator is not alert to the presence of children. Children are often attracted to the machine and the mowing activity. Never assume that children will remain where you last saw them.

- Keep children out of the mowing area and in the watchful care of a responsible adult other than the operator.
- Be alert and turn machine off if a child enters the area.
- Before and while backing, look behind and down for small children.
- Never carry children, even with the blades shut off. They may fall off and be seriously injured or interfere with safe machine operation. Children who have been given rides in the past may suddenly appear in the mowing area for another ride and be run over or backed over by the machine.
- Never allow children to operate the machine.
- Use extra care when approaching blind corners, shrubs, trees, or other objects that may block your view of a child.

IV. TOWING

- Tow only with a machine that has a hitch designed for towing. Do not attach towed equipment except at the hitch point.
- Follow the manufacturer's recommendation for weight limits for towed equipment and towing on slopes.
- Never allow children or others in or on towed equipment.
- On slopes, the weight of the towed equipment may cause loss of traction and loss of control.
- Travel slowly and allow extra distance to stop.

V. SERVICE

SAFE HANDLING OF GASOLINE

To avoid personal injury or property damage, use extreme care in handling gasoline. Gasoline is extremely flammable and the vapors are explosive.

- Extinguish all cigarettes, cigars, pipes, and other sources of ignition.
- Use only approved gasoline container.
- Never remove gas cap or add fuel with the engine running. Allow engine to cool before refueling.
- Never fuel the machine indoors.
- Never store the machine or fuel container where there is an open flame, spark, or pilot light such as on a water heater or other appliances.
- Never fill containers inside a vehicle or on a truck or trailer bed with plastic liner. Always place containers on the ground away from your vehicle when filling.
- Remove gas-powered equipment from the truck or trailer and refuel it on the ground. If this is not possible, then refuel such equipment with a portable container, rather than from a gasoline dispenser nozzle.
- Keep the nozzle in contact with the rim of the fuel tank or container opening at all times until fueling is complete. Do not use a nozzle lock-open device.
- If fuel is spilled on clothing, change clothing immediately.
- Never overfill fuel tank. Replace gas cap and tighten securely.

GENERAL SERVICE

- Never operate machine in a closed area.
- Keep all nuts and bolts tight to be sure the equipment is in safe working condition.
- Never tamper with safety devices. Check their proper operation regularly.
- Keep machine free of grass, leaves, or other debris build-up. Clean oil or fuel spillage and remove any fuel-soaked debris. Allow machine to cool before storing.
- If you strike a foreign object, stop and inspect the machine. Repair, if necessary, before restarting.
- Never make any adjustments or repairs with the engine running.
- Check grass catcher components and the discharge chute frequently and replace with manufacturer's recommended parts, when necessary.
- Mower blades are sharp. Wrap the blade or wear gloves, and use extra caution when servicing them.
- Check brake operation frequently. Adjust and service as required.
- Maintain or replace safety and instruction labels, as necessary.



- Be sure the area is clear of bystanders before operating. Stop machine if anyone enters the area.
- Never carry passengers.
- Do not mow in reverse unless absolutely necessary. Always look down and behind before and while backing.
- Never carry children, even with the blades shut off. They may fall off and be seriously injured or interfere with safe machine operation. Children who have been given rides in the past may suddenly appear in the mowing area for another ride and be run over or backed over by the machine.
- Keep children out of the mowing area and in the watchful care of a responsible adult other than the operator.
- Be alert and turn machine off if a child enters the area.
- Before and while backing, look behind and down for small children.
- Mow up and down slopes (15° Max), not across.
- Choose a low ground speed so that you will not have to stop or shift while on the slope.
- Avoid starting, stopping, or turning on a slope. If the tires lose traction, disengage the blades and proceed slowly straight down the slope.
- If machine stops while going uphill, disengage blades, shift into reverse and back down slowly.
- Do not turn on slopes unless necessary, and then, turn slowly and gradually downhill, if possible.

PRODUCT SPECIFICATIONS

Gasoline Capacity and type:	4 Gallons Unleaded Regular
Oil Type (API-SG-SL):	SAE 30 (above 32°F) SAE 5W-30 (below 32°F) Synthetic (below 0°F)
Your tractor was shipped from the factory with non-synthetic SAE 10W30 motor oil	
Oil Capacity:	W/Filter: 64 oz. W/O Filter: 60 oz.
Spark Plug:	Champion QC12YC (Gap: .040")
Ground Speed (MPH):	Forward: 0-5.2 Reverse: 0-2.9
Charging System:	16 Amps @ 3600RPM
Battery:	AMP/HR: 28 Min. CCA: 230 Case Size: U1R
Blade Bolt Torque:	45-55 FT. LBS.

CONGRATULATIONS on your purchase of a new Tractor. It has been designed, engineered and manufactured to give you the best possible dependability and performance.

Should you experience any problem you cannot easily remedy, please contact your nearest authorized service center/department. We have competent, well-trained technicians and the proper tools to service or repair this tractor.

Please read and retain this manual. The instructions will enable you to assemble and maintain your tractor properly. Always observe the "SAFETY RULES".

MAINTENANCE AGREEMENT

A Maintenance Agreement is available on this product. Contact your nearest Sears store for details.

CUSTOMER RESPONSIBILITIES

- Read and observe the safety rules.
- Follow a regular schedule in maintaining, caring for and using your tractor.
- Follow the instructions under "Maintenance" and "Storage" sections of this manual.

WARNING: This tractor is equipped with an internal combustion engine and should not be used on or near any unimproved forest-covered, brush-covered or grass-covered land unless the engine's exhaust system is equipped with a spark arrester meeting applicable local or state laws (if any). If a spark arrester is used, it should be maintained in effective working order by the operator.

A spark arrester for the muffler is available through your nearest authorized service center/department (See REPAIR PARTS section of this manual).

TABLE OF CONTENTS

SAFETY RULES	2-3
PRODUCT SPECIFICATIONS.....	4
CUSTOMER RESPONSIBILITIES.....	4
ASSEMBLY	5-9
OPERATION	10-16
MAINTENANCE SCHEDULE	17
MAINTENANCE	17-21
SERVICE AND ADJUSTMENTS	22-26

STORAGE.....	27
TROUBLESHOOTING	28-29
REPAIR PARTS - TRACTOR	31-45
REPAIR PARTS - TRANSAXLE.....	46-47
REPAIR PARTS - ENGINE	48-53
WARRANTY.....	54
PARTS ORDERING/SERVICE	BACK COVER

UNASSEMBLED PARTS

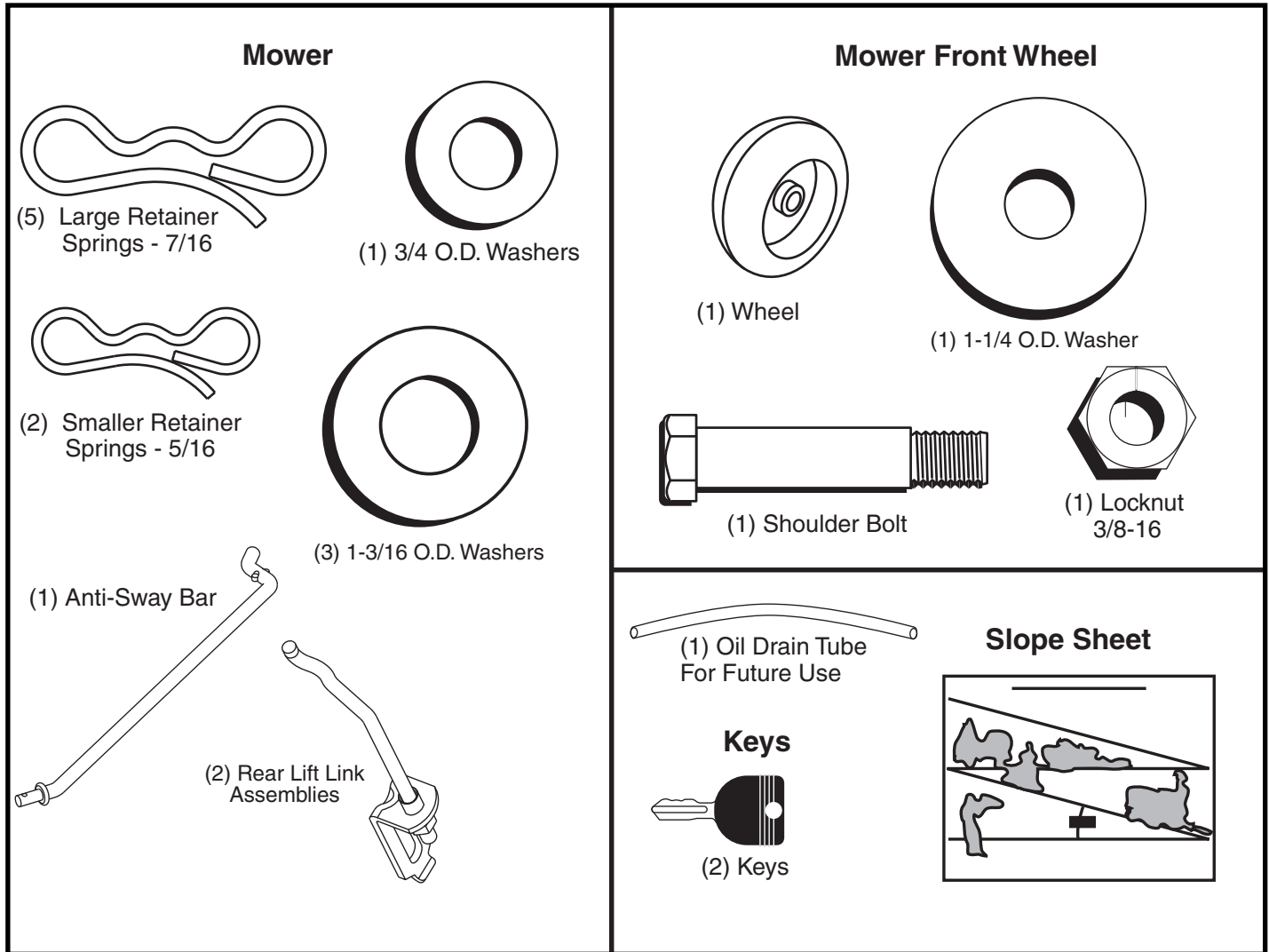

ASSEMBLY

Your new tractor has been assembled at the factory with exception of those parts left unassembled for shipping purposes. To ensure safe and proper operation of your tractor all parts and hardware you assemble must be tightened securely. Use the correct tools as necessary to ensure proper tightness.

TOOLS REQUIRED FOR ASSEMBLY

A socket wrench set will make assembly easier. Standard wrench sizes are listed.

- | | |
|---------------------------------|---------------------|
| (2) 7/16" wrenches | Utility knife |
| (1) 1/2" wrench | Tire pressure gauge |
| (1) 3/4" wrench | Pliers |
| (1) 3/4" socket w/drive ratchet | |

When right or left hand is mentioned in this manual, it means when you are in the operating position (seated behind the steering wheel).

TO REMOVE TRACTOR FROM CARTON

UNPACK CARTON

- Remove all accessible loose parts and parts cartons from carton .
- Cut along dotted lines on all four panels of carton. Remove end panels and lay side panels flat.
- Remove mower and packing materials.
- Check for any additional loose parts or cartons and remove.

ASSEMBLY

BEFORE REMOVING TRACTOR FROM SKID

TO CHECK BATTERY (See Fig. 1)

- Lift hood to raised position.

NOTE: If this battery is put into service after month and year indicated on label (label is located between terminals) charge battery for minimum of one hour at 6-10 amps. (See "BATTERY" in Maintenance section of this manual for charging instructions).

- For battery and battery cable installation see "REPLACING BATTERY" in the "Service and Adjustments" section in this manual.

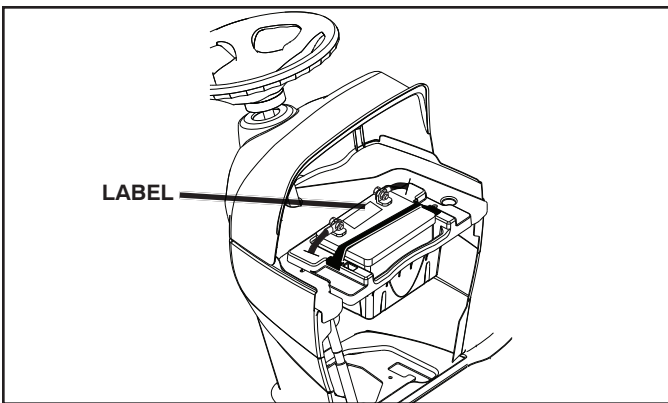

Fig. 1

ADJUST SEAT (See Fig. 2)

- Sit in seat.
- Lift up adjustment lever (A) and slide seat until a comfortable position is reached which allows you to press clutch/brake pedal all the way down.
- Release lever to lock seat in position.

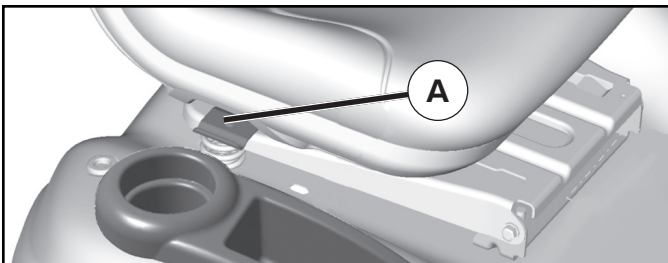

Fig. 2

NOTE: You may now roll your tractor off the skid. Follow the appropriate instruction below to remove the tractor from the skid.

⚠ WARNING: Before starting, read, understand and follow all instructions in the Operation section of this manual. Be sure tractor is in a well-ventilated area. Be sure the area in front of tractor is clear of other people and objects.

TO ROLL TRACTOR OFF SKID (See Operation section for location and function of controls)

- Raise attachment lift lever to its highest position.
- Release parking brake by depressing brake pedal.
- Place freewheel control in disengaged position to disengage transmission (See "TO TRANSPORT" in the Operation section of this manual).
- Roll tractor forward off skid.
- Release parking brake.
- Slowly depress forward drive pedal and drive tractor off skid.
- Apply brake to stop tractor and set parking brake.
- Turn ignition key to "STOP" position.

Continue with the instructions that follow.

TO INSTALL MOWER (See Figs. 3 - 15)

1. SET PARKING BRAKE LEVER AND LOWER ATTACHMENT LIFT LEVER (See Fig. 4 and 5)

- Depress clutch/brake pedal all the way down and hold.
- Pull parking brake lever up and hold, release pressure from clutch/brake pedal, then release parking brake lever. Pedal should remain in brake position. Ensure parking brake will hold tractor secure.



Fig. 3



CAUTION: Lift lever is spring loaded. Have a tight grip on lift lever, lower it slowly and engage in lowest position. Lift lever is located on left side of fender.

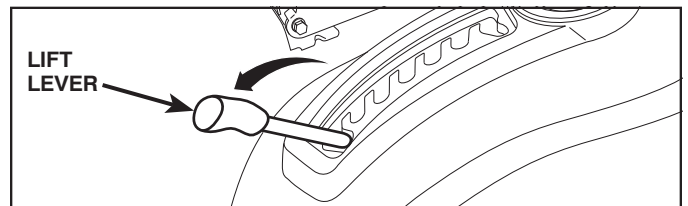
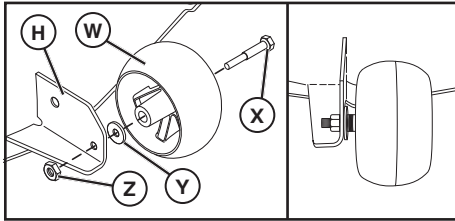

Fig. 4

ASSEMBLY

2. ASSEMBLE FRONT GAUGE WHEEL (W) TO FRONT OF MOWER (See Fig. 5)



- H. FRONT MOWER BRACKET
- W. FRONT GAUGE WHEEL
- X. SHOULDER BOLT
- Y. 1-1/4 O.D. WASHER
- Z. 3/8-16 LOCKNUT

Fig. 5

3. TURN STEERING WHEEL LEFT AND POSITION MOWER (See Fig. 6)

- Turn steering wheel to the left as far as it will go and position mower on right side of tractor with deflector shield (Q) to the right.

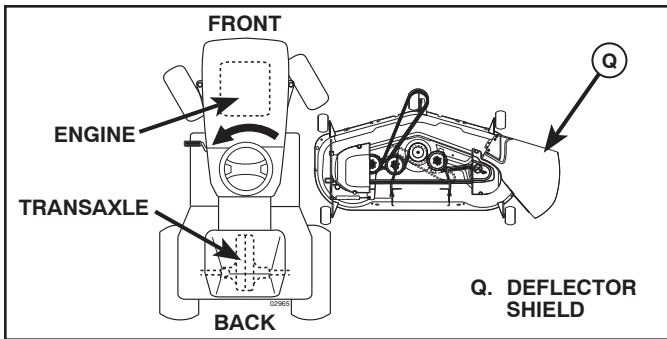

Fig. 6

4. SLIDE MOWER UNDER TRACTOR (See Fig. 7)

- Bring belt forward and check belt for proper routing in all mower pulley grooves.

NOTE: Be sure mower side suspension arms (A) are pointing forward before sliding mower under tractor.

- Slide mower under tractor until it is centered under tractor.

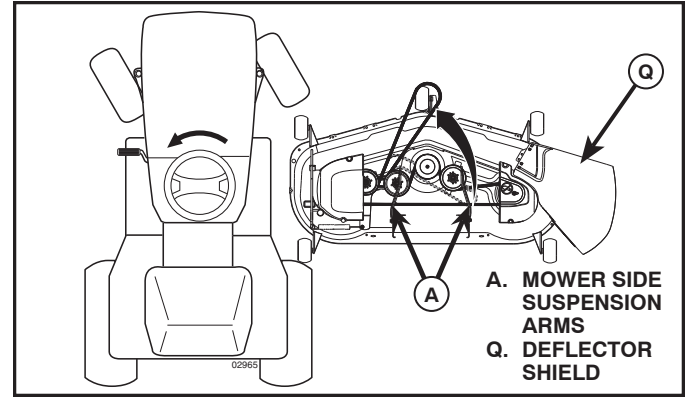

Fig. 7

5. INSTALL ANTI-SWAY BAR (S) (IF EQUIPPED) (See Fig. 8 - 11)

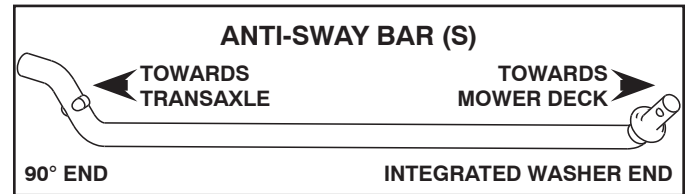

Fig. 8

- From right side of mower, first insert 90° end of anti-sway bar (S) into hole in transaxle bracket (T), located near left rear tire in front of transaxle.

NOTE: Flashlight may be helpful.

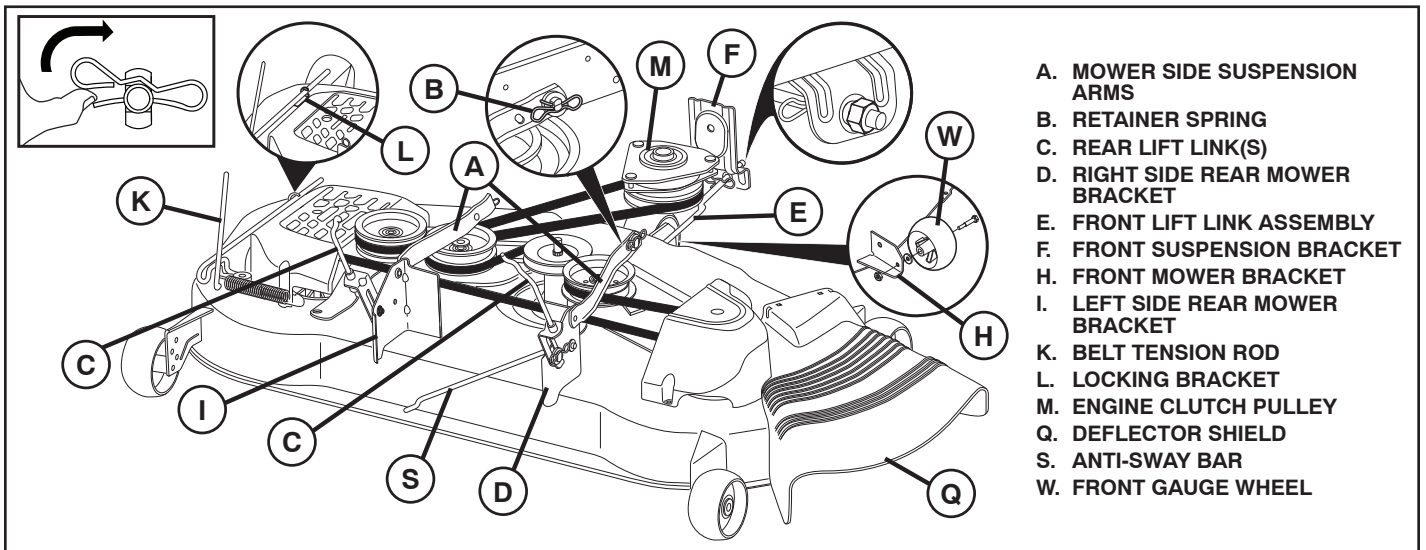

Fig. 9

ASSEMBLY

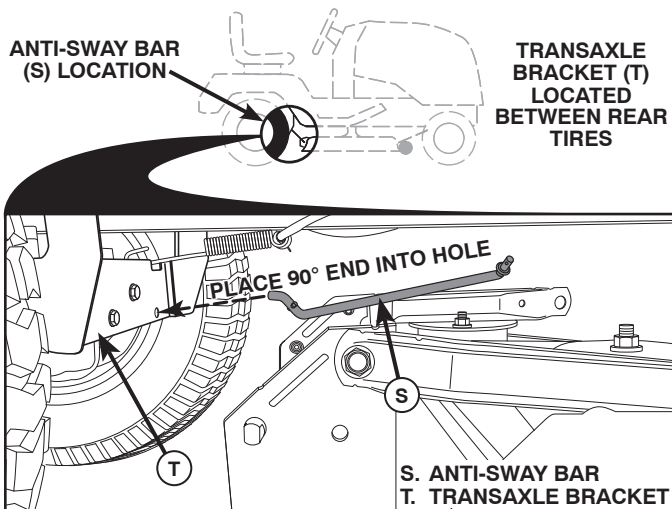

Fig. 10

NOTE: Depending on model, bracket (T) may be different than shown but hole for anti-sway bar will be in same position/location.

- Pivot the integrated washer end of anti-sway bar (S) towards mower deck bracket on right side of mower. Insert integrated washer end of bar into hole in rear mower bracket (D). Move mower as needed to insert integrated washer end of bar into rear mower bracket (D).
- Secure with small washer and small retainer spring as shown.

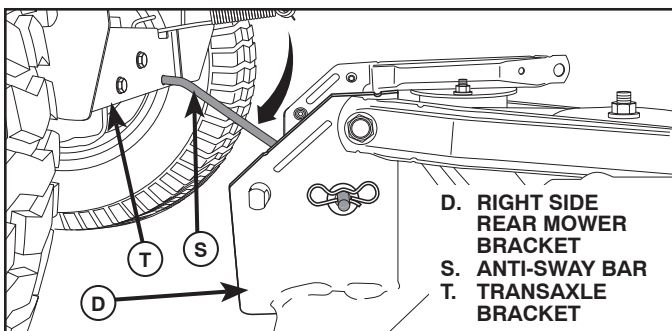

Fig. 11

6. ATTACH MOWER SIDE SUSPENSION ARMS (A) TO CHASSIS (See Fig. 12)

- Position front hole in side suspension arm (A) over pin on outside of tractor chassis and secure with large washer and large retainer spring (B).
- Repeat on opposite side of tractor.

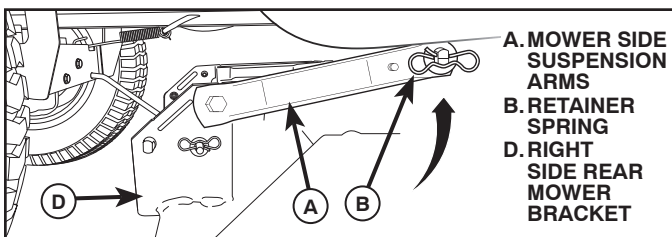

Fig. 12

7. ATTACH REAR LIFT LINKS (C) (See Fig. 14)

- Insert rod end of rear lift link (C) into hole (U) in tractor lift shaft suspension arm and pivot link down to mower.
- Lift rear corner of mower and position slot in link assembly over pin on rear mower bracket (D) and secure with large washer and large retainer spring.
- Repeat on opposite side of tractor.

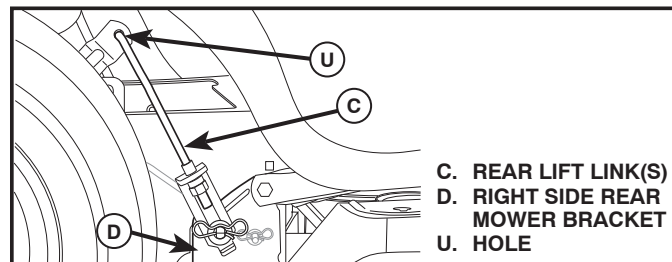

Fig. 13

8. ATTACH FRONT LINK (E) (See Fig. 14)

- Turn steering wheel to position wheels straight forward.
- From front of tractor, insert rod end of front link (E) through front hole in tractor front suspension bracket (F).
- Move to left side of mower and insert large retainer spring (G) through hole in front link (E) behind front suspension bracket (F).
- Insert other end of link (E) into hole in front mower bracket (H) and secure with washer and small retainer spring (J).

NOTE: Requires deck lifting.

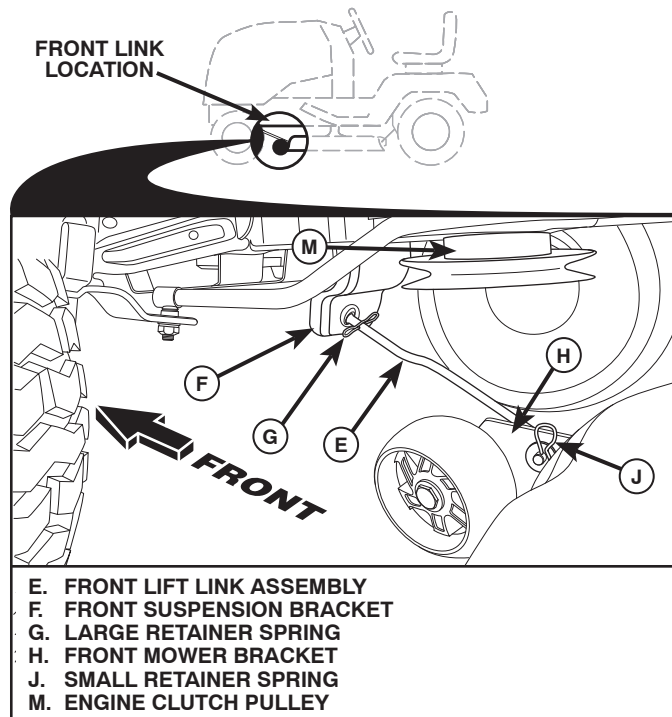

Fig. 14

ASSEMBLY

9 INSTALL BELT ON ENGINE CLUTCH PULLEY (M) (See Fig. 9 & 15)

- Disengage belt tension rod (K) from locking bracket (L).
- Install belt onto engine clutch pulley (M).

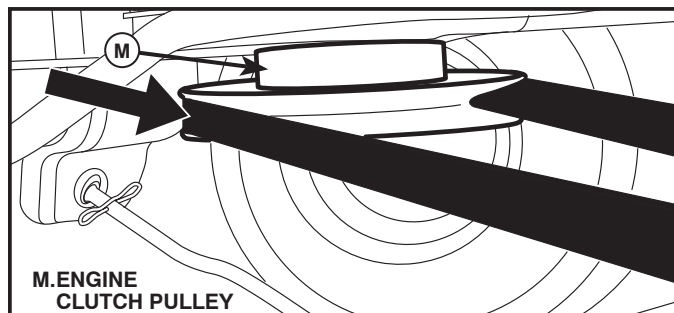

Fig. 15

IMPORTANT: Check belt for proper routing in all mower pulley grooves and under mandrel covers.

- Engage belt tension rod (K) on locking bracket (L).



CAUTION: Belt tension rod is spring loaded. Have a tight grip on rod and engage slowly.

- Raise attachment lift lever to highest position.
- If necessary, adjust gauge wheels before operating mower as shown in the Operation section of this manual.

MOWER DRIVE BELT INSTALLATION

Follow procedure described in "TO REPLACE MOWER BLADE DRIVE BELT" in the "Service and Adjustments" section of this manual.

CHECK TIRE PRESSURE

The tires on your tractor were overinflated at the factory for shipping purposes. Correct tire pressure is important for best cutting performance.

- Reduce tire pressure to PSI shown on tires.

CHECK DECK LEVELNESS

For best cutting results, mower housing should be properly leveled. See "TO LEVEL MOWER HOUSING" in the Service and Adjustments section of this manual.

CHECK FOR PROPER POSITION OF ALL BELTS

See the figures that are shown for replacing motion and mower blade drive belts in the Service and Adjustments section of this manual. Verify that the belts are routed correctly.

CHECK BRAKE SYSTEM

After you learn how to operate your tractor, check to see that the brake is operating properly. See "TO CHECK BRAKE" in the Service and Adjustments section of this manual.

✓ CHECKLIST

BEFORE YOU OPERATE YOUR NEW TRACTOR, WE WISH TO ASSURE THAT YOU RECEIVE THE BEST PERFORMANCE AND SATISFACTION FROM THIS QUALITY PRODUCT.

PLEASE REVIEW THE FOLLOWING CHECKLIST:

- ✓ All assembly instructions have been completed.
- ✓ No remaining loose parts in carton.
- ✓ Battery is properly prepared and charged.
- ✓ Seat is adjusted comfortably and tightened securely.
- ✓ All tires are properly inflated. (For shipping purposes, the tires were overinflated at the factory).
- ✓ Be sure mower deck is properly leveled side-to-side/front-to-rear for best cutting results. (Tires must be properly inflated for leveling).
- ✓ Check mower and drive belts. Be sure they are routed properly around pulleys and inside all belt keepers.
- ✓ Check wiring. See that all connections are still secure and wires are properly clamped.
- ✓ Before driving tractor, be sure freewheel control is in "transmission engaged" position (see "TO TRANSPORT" in the Operation section of this manual).

WHILE LEARNING HOW TO USE YOUR TRACTOR, PAY EXTRA ATTENTION TO THE FOLLOWING IMPORTANT ITEMS:

- ✓ Engine oil is at proper level.
- ✓ Fuel tank is filled with fresh, clean, regular unleaded gasoline.
- ✓ Become familiar with all controls, their location and function. Operate them before you start the engine.
- ✓ Be sure brake system is in safe operating condition.
- ✓ Be sure Operator Presence System and Reverse Operation System (ROS) are working properly (See the Operation and Maintenance sections in this manual).
- ✓ It is important to purge the transmission before operating your tractor for the first time. Follow proper starting and transmission purging instructions (See "TO START ENGINE" and "PURGE TRANSMISSION" in the Operation section of this manual).

OPERATION

These symbols may appear on your tractor or in literature supplied with the product. Learn and understand their meaning.

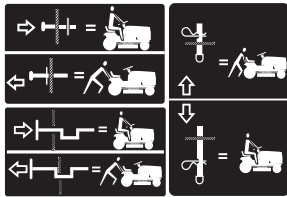

FREE WHEEL
(Automatic Models only)



Failure to follow instructions could result in serious injury or death. The safety alert symbol is used to identify safety information about hazards which can result in death, serious injury and/or property damage.



DANGER indicates a hazard which, if not avoided, will result in death or serious injury.



WARNING indicates a hazard which, if not avoided, could result in death or serious injury.



CAUTION indicates a hazard which, if not avoided, might result in minor or moderate injury.

CAUTION when used **without** the alert symbol, indicates a situation that **could result in damage to the tractor and/or engine.**



HOT SURFACES indicates a hazard which, if not avoided, could result in death, serious injury and/or property damage.



FIRE indicates a hazard which, if not avoided, could result in death, serious injury and/or property damage.

OPERATION

KNOW YOUR TRACTOR

READ THIS OWNER'S MANUAL AND SAFETY RULES BEFORE OPERATING YOUR TRACTOR

Compare the illustrations with your tractor to familiarize yourself with the locations of various controls and adjustments. Save this manual for future reference.

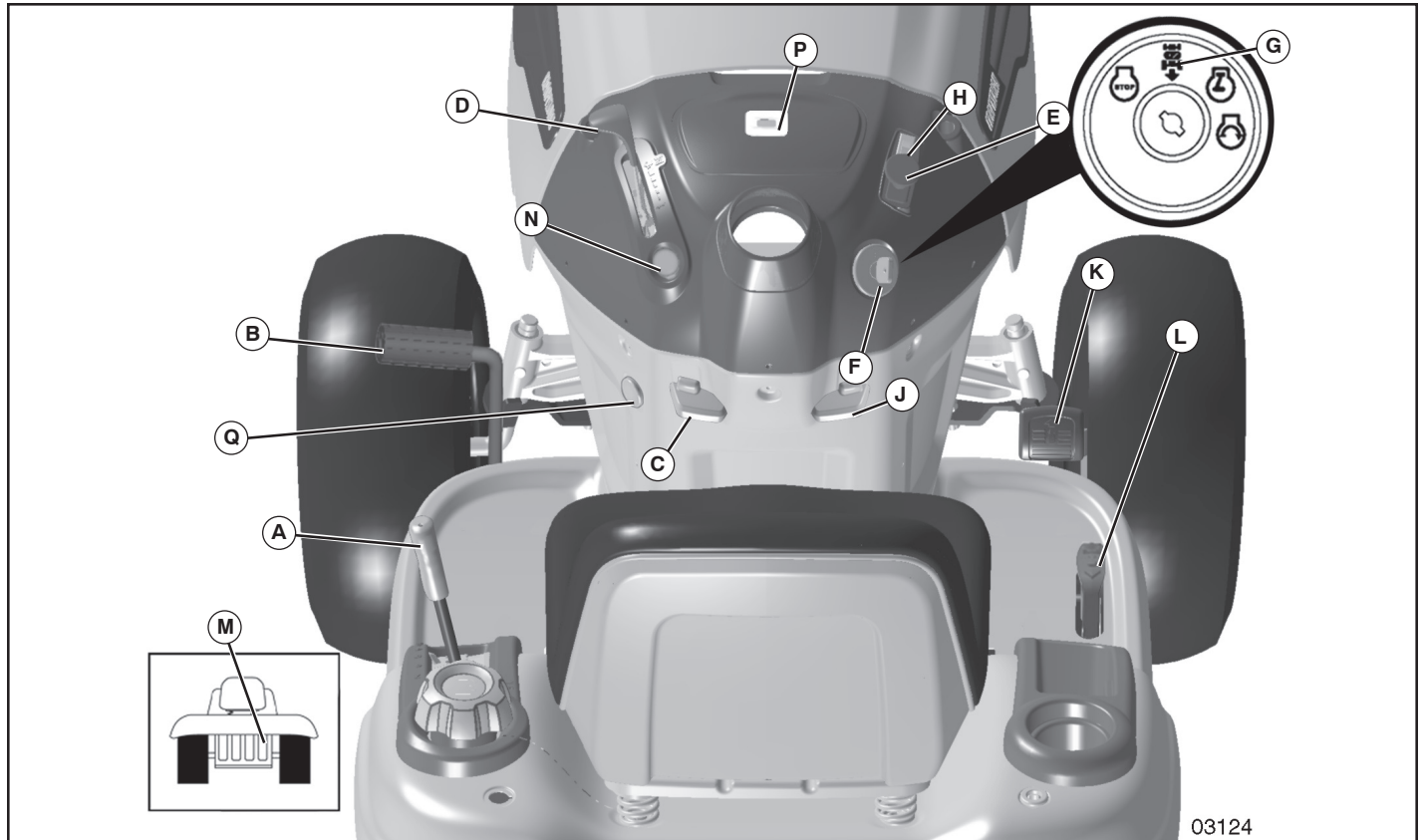

Fig. 16

Our tractors conform to the applicable safety standards of the American National Standards Institute.

(A) ATTACHMENT LIFT LEVER – Used to raise and lower the mower or other attachments mounted to your tractor.

(B) BRAKE PEDAL – Used for braking the tractor and starting the engine.

(C) PARKING BRAKE – Locks clutch/brake pedal into the brake position.

(D) THROTTLE CONTROL – Used to control engine speed.

(E) ATTACHMENT CLUTCH SWITCH – Used to engage the mower blades, or other attachments mounted to your tractor.

(F) IGNITION SWITCH – Used for starting and stopping the engine.

(G) REVERSE OPERATION SYSTEM (ROS) "ON" POSITION – Allows operation of mower or other powered attachment while in reverse.

(H) LIGHT SWITCH – Turns the headlights on and off.

(J) CRUISE CONTROL LEVER – Used to set forward movement of tractor at desired speed without holding the forward drive pedal.

(K) FORWARD DRIVE PEDAL – Used for forward movement of tractor.

(L) REVERSE DRIVE PEDAL – Used for reverse movement of tractor.

(M) FREEWHEEL CONTROL – Disengages transmission for pushing or slowly towing the tractor with the engine off.

(N) CHOKE CONTROL – Used when starting a cold engine.

(P) SERVICE REMINDER / HOUR METER – Indicates when service is required for the engine and mower.

(Q) 12-VOLT POWER PORT – Used for 12-volt accessories.

OPERATION



The operation of any tractor can result in foreign objects thrown into the eyes, which can result in severe eye damage. Always wear safety glasses or eye shields while operating your tractor or performing any adjustments or repairs. We recommend standard safety glasses or a wide vision safety mask worn over spectacles.

HOW TO USE YOUR TRACTOR

TO SET PARKING BRAKE(See Fig. 17)

Your tractor is equipped with an operator presence sensing switch. When engine is running, any attempt by the operator to leave the seat without first setting the parking brake will shut off the engine.

- Depress brake pedal (B) all the way down and hold.
- Pull parking brake lever (C) up and hold, release pressure from brake pedal (B), then release parking brake lever. Pedal should remain in brake position. Make sure parking brake will hold tractor secure.

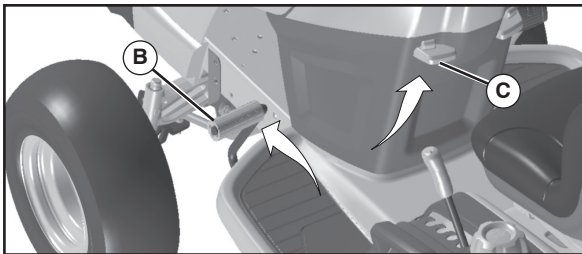
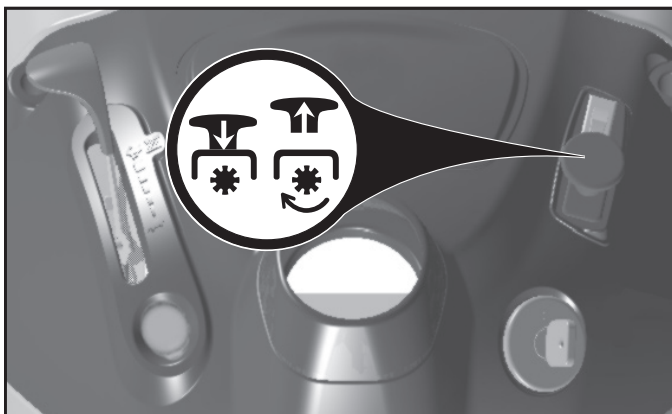

Fig. 17

STOPPING

MOWER BLADES

- To stop mower blades, push attachment clutch switch in to disengaged position (☒).



(☒) ATTACHMENT CLUTCH SWITCH "DISENGAGED"

(☑) ATTACHMENT CLUTCH SWITCH "ENGAGED"

Fig. 18

GROUND DRIVE -

- To stop ground drive, depress brake pedal all the way down.

ENGINE -

- Move throttle control (D) between half and full speed (fast) position.

NOTE: Failure to move throttle control between half and full speed (fast) position, before stopping, may cause engine to "backfire".

- Turn ignition key (F) to "STOP" position and remove key. Always remove key when leaving tractor to prevent unauthorized use.
- Never use choke (N) to stop engine.

IMPORTANT: Leaving the ignition switch in any position other than "STOP" will cause the battery to discharge and go dead.

NOTE: Under certain conditions when tractor is standing idle with the engine running, hot engine exhaust gases may cause "browning" of grass. To eliminate this possibility, always stop engine when stopping tractor on grass areas.



CAUTION: Always stop tractor completely, as described above, before leaving the operator's position.

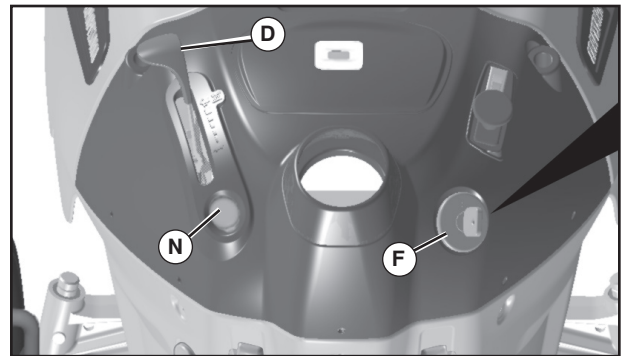

Fig. 19

TO USE THROTTLE CONTROL -D (See Fig. 19)

Always operate engine at full speed (fast).

- Operating engine at less than full speed (fast) reduces engines operating efficiency.
- Full speed (fast) offers the best bagging and mower performance.

TO USE CHOKE CONTROL -N (See Fig. 19)

Use choke control whenever you are starting a cold engine. Do not use to start a warm engine.

- To engage choke control, pull knob out. Slowly push knob in to disengage.

TO MOVE FORWARD AND BACKWARD (See Fig. 20)

The direction and speed of movement is controlled by the forward and reverse drive pedals.

- Start tractor and release parking brake.
- Slowly depress forward (K) or reverse (L) drive pedal to begin movement. Ground speed increases the further down the pedal is depressed.

OPERATION

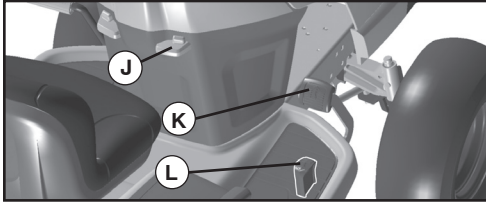

Fig. 20

TO USE CRUISE CONTROL -J (See Fig. 20)

The cruise control feature can be used for forward travel only.

SYSTEM CHARACTERISTICS

The cruise control should only be used while mowing or transporting on relatively smooth, straight surfaces. Other conditions such as trimming at slow speeds may cause the cruise control to disengage. Do not use the cruise control on slopes, rough terrain or while trimming or turning.

- With forward drive pedal depressed to desired speed, pull cruise control lever (J) up and hold while lifting your foot off the pedal, then release the lever.

To disengage the cruise control, depress the brake pedal or tap on forward drive pedal.

TO ADJUST MOWER CUTTING HEIGHT (See Fig. 21)

The position of the attachment lift lever (A) determines the cutting height.

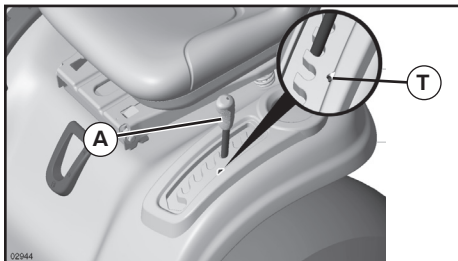

Fig. 21

- Put attachment lift lever in desired cutting height slot.
- Slide pointer tab (T) to desired cutting height as a reminder for next time you mow.

The cutting height range is approximately 1" to 4". The heights are measured from the ground to the blade tip with the engine not running. These heights are approximate and may vary depending upon soil conditions, height of grass and types of grass being mowed.

- The average lawn should be cut to approximately 2-1/2" during the cool season and to over 3" during hot months. For healthier and better looking lawns, mow often and after moderate growth.
- For best cutting performance, grass over 6" in height should be mowed twice. Make the first cut relatively high; the second to desired height.

TO ADJUST GAUGE WHEELS (See Fig. 22)

Gauge wheels are properly adjusted when they are slightly off the ground when mower is at the desired cutting height in operating position. Gauge wheels then keep the deck in proper position to help prevent scalping in most terrain conditions.

NOTE: Adjust gauge wheels with tractor on a flat level surface.

- Adjust mower to desired cutting height (See "TO ADJUST MOWER CUTTING HEIGHT" in this section of manual).
- With mower in desired height of cut position, gauge wheels should be assembled so they are slightly off the ground. Install gauge wheel in appropriate hole. Tighten securely.
- Repeat for all, installing gauge wheel in same adjustment hole.

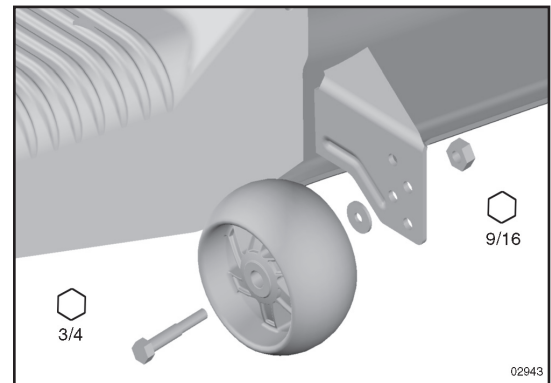

Fig. 22

TO OPERATE MOWER

Your tractor is equipped with an operator presence sensing switch. Any attempt by the operator to leave the seat with the engine running and the attachment clutch engaged will shut off the engine. You must remain fully and centrally positioned in the seat to prevent the engine from hesitating or cutting off when operating your equipment on rough, rolling terrain or hills.

1. Select desired height of cut with attachment lift lever.
2. Start mower blades by engaging attachment clutch control.

TO STOP MOWER BLADES

Disengage attachment clutch control.



CAUTION: Do not operate the mower without either the entire grass catcher, on mowers so equipped, or the deflector shield (S) in place. (fig. 23)

OPERATION

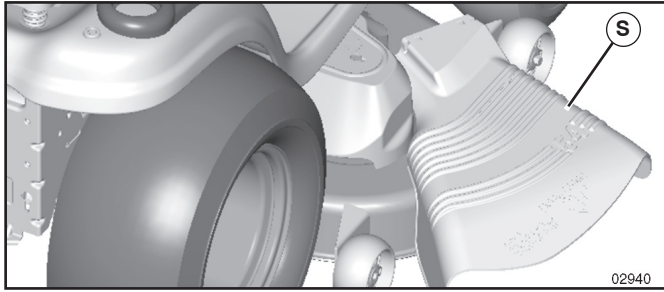

Fig. 23

REVERSE OPERATION SYSTEM (ROS)

Your tractor is equipped with a Reverse Operation System (ROS). Any attempt by the operator to travel in the reverse direction with the attachment clutch engaged will shut off the engine unless ignition key is placed in the ROS "ON" position.

WARNING: Backing up with the attachment clutch engaged while mowing is strongly discouraged. Turning the ROS "ON", to allow reverse operation with the attachment clutch engaged, should only be done when the operator decides it is necessary to reposition the machine with the attachment engaged. **Do not mow in reverse unless absolutely necessary.**

USING THE REVERSE OPERATION SYSTEM -

Only use if you are certain no children or other bystanders will enter the mowing area.

- Depress brake pedal all the way down.
- With engine running, turn ignition key counterclockwise to ROS "ON" position.
- Look down and behind before and while backing.
- Slowly depress reverse drive pedal to start movement.
- When use of the ROS is no longer needed, turn the ignition key clockwise to engine "ON" position.

ROS "ON" POSITION



ENGINE "ON" POSITION (NORMAL OPERATING)



TO OPERATE ON HILLS



CAUTION: Do not drive up or down hills with slopes greater than 15° and do not drive across any slope.

- Choose the slowest speed before starting up or down hills.
- Avoid stopping or changing speed on hills.
- If stopping is absolutely necessary, push brake pedal quickly to brake position and engage parking brake.

- To restart movement, slowly release parking brake and brake pedal.
- Slowly depress appropriate drive pedal to slowest setting.
- Make all turns slowly.

TO TRANSPORT (See Figs. 16 and 24)

When pushing or towing your tractor, be sure to disengage transmission by placing freewheel control in freewheeling position. Free wheel control is located at the rear drawbar of tractor.

- Raise attachment lift to highest position with attachment lift control.
- Pull freewheel control out and down into the slot and release so it is held in the disengaged position.
- Do not push or tow tractor at more than two (2) MPH.
- To reengage transmission, reverse above procedure.

NOTE: To protect hood from damage when transporting your tractor on a truck or a trailer, be sure hood is closed and secured to tractor. Use an appropriate means of tying hood to tractor (rope, cord, etc.).

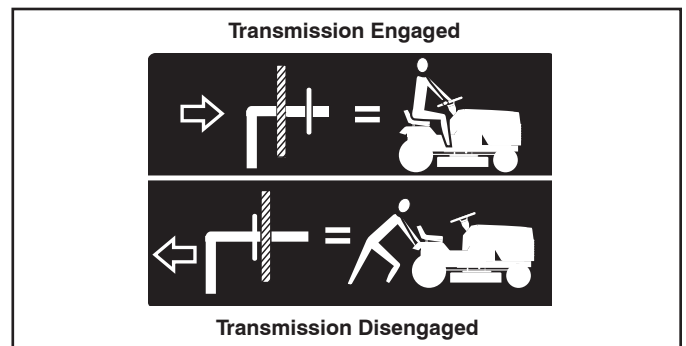

Fig. 24

SERVICE REMINDER/HOUR METER

Service reminder shows the total number of hours the engine has run and flashes to indicate that the engine or mower needs servicing. When service is required, the service reminder will flash for two hours. To service engine and mower, see the Maintenance section of this manual.

NOTE: Service reminder runs when the ignition key is in any position but "STOP". For accurate reading, be sure key remains in the "STOP" position when engine is not running.

TOWING CARTS AND OTHER ATTACHMENTS

Tow only the attachments that are recommended by and comply with specifications of the manufacturer of your tractor. Use common sense when towing. Too heavy of a load, while on a slope, is dangerous. Tires can lose traction with the ground and cause you to lose control of your tractor.

OPERATION

BEFORE STARTING THE ENGINE

CHECK ENGINE OIL LEVEL

The engine in your tractor has been shipped, from the factory, already filled with summer weight oil.

- Check engine oil with tractor on level ground.
- Unthread and remove oil fill cap/dipstick; wipe oil off. Reinsert the dipstick into the tube and rest oil fill cap on the tube. Do not thread the cap onto the tube. Remove and read oil level. If necessary, add oil until "FULL" mark on dipstick is reached. Do not overfill.
- For cold weather operation you should change oil for easier starting (See "OIL VISCOSITY CHART" in the Maintenance section of this manual).
- To change engine oil, see the Maintenance section in this manual.

ADD GASOLINE

- Fill fuel tank to bottom of filler neck. Do not overfill. Use fresh, clean, regular unleaded gasoline with a minimum of 87 octane. (Use of leaded gasoline will increase carbon and lead oxide deposits and reduce valve life). Do not mix oil with gasoline. Purchase fuel in quantities that can be used within 30 days to assure fuel freshness.



CAUTION: Wipe off any spilled oil or fuel. Do not store, spill or use gasoline near an open flame.

IMPORTANT: WHEN OPERATING IN TEMPERATURES BELOW 32°F (0°C), USE FRESH, CLEAN WINTER GRADE GASOLINE TO HELP ENSURE GOOD COLD WEATHER STARTING.

CAUTION: Alcohol blended fuels (called gasohol or using ethanol or methanol) can attract moisture which leads to separation and formation of acids during storage. Acidic gas can damage the fuel system of an engine while in storage. To avoid engine problems, the fuel system should be emptied before storage of 30 days or longer. Drain the gas tank, start the engine and let it run until the fuel lines and carburetor are empty. Use fresh fuel next season. See Storage Instructions for additional information. Never use engine or carburetor cleaner products in the fuel tank or permanent damage may occur.

RESERVE FUEL VALVE OPERATION (See Fig. 25)

1. Raise seat to access reserve fuel valve.
2. In normal operation, valve should be set to primary (as shown in view)
3. If tractor runs out of fuel, rotate valve handle to reserve.
4. Drive tractor to be refueled.
5. After refueling, return valve to primary position.

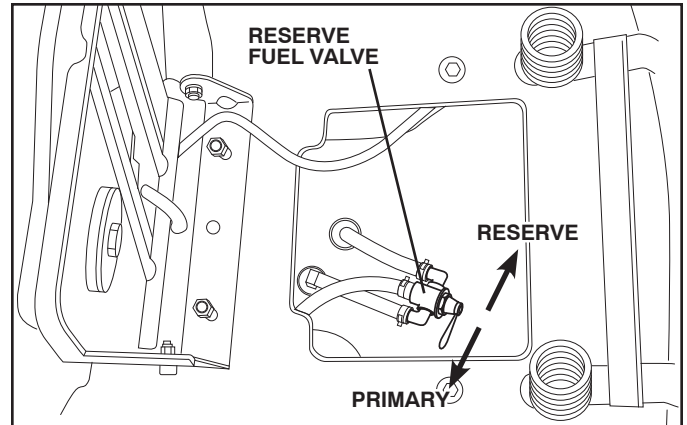

Fig. 25

TO START ENGINE (See Fig. 16)

When starting the engine for the first time or if the engine has run out of fuel, it will take extra cranking time to move fuel from the tank to the engine.

- Be sure freewheel control is in the transmission engaged position.
- Sit on seat in operating position, depress brake pedal and set parking brake.
- Move attachment clutch to "DISENGAGED" position.
- Move throttle control to fast position
- Pull choke control out for a cold engine start attempt. For a warm engine start attempt the choke control may not be needed.

NOTE: Before starting, read the warm and cold starting procedures below.

- Insert key into ignition and turn key clockwise to "START" position and release key as soon as engine starts. Do not run starter continuously for more than fifteen seconds per minute. If the engine does not start after several attempts, push choke control in, wait a few minutes and try again. If engine still does not start, pull the choke control out and retry.

WARM WEATHER STARTING (50° F/10° C and above)

- When engine starts, slowly push choke control in until the engine begins to run smoothly. If the engine starts to run roughly, pull the choke control out slightly for a few seconds and then continue to push the control in slowly.
- The attachments and ground drive can now be used. If the engine does not accept the load, restart the engine and allow it to warm up for one minute using the choke as described above.

COLD WEATHER STARTING (50° F/10° C and below)

- When engine starts, slowly push choke control in until the engine begins to run smoothly. Continue to push the choke control in small steps allowing the engine to accept small changes in speed and load, until the choke control is fully in. If the engine starts to run roughly, pull the choke control out slightly for a few seconds and then continue to push the control in slowly. This may require an engine warm-up period from several seconds to several minutes, depending on the temperature.

OPERATION

AUTOMATIC TRANSMISSION WARM UP

- Before driving the unit in cold weather, the transmission should be warmed up as follows:
 - Be sure the tractor is on level ground.
 - Release the parking brake and let the brake slowly return to operating position.
 - Allow one minute for transmission to warm up. This can be done during the engine warm up period.
- The attachments can be used during the engine warm-up period after the transmission has been warmed up and may require the choke control be pulled out slightly.

NOTE: If at a high altitude (above 3000 feet) or in cold temperatures (below 32° F/0° C) the carburetor fuel mixture may need to be adjusted for best engine performance. See "TO ADJUST CARBURETOR" in the Service and Adjustments section of this manual.

PURGE TRANSMISSION



CAUTION: Never engage or disengage freewheel lever while the engine is running.

To ensure proper operation and performance, it is recommended that the transmission be purged before operating tractor for the first time. This procedure will remove any trapped air inside the transmission which may have developed during shipping of your tractor.

IMPORTANT: SHOULD YOUR TRANSMISSION REQUIRE REMOVAL FOR SERVICE OR REPLACEMENT, IT SHOULD BE PURGED AFTER REINSTALLATION BEFORE OPERATING THE TRACTOR.

1. Place tractor safely on a level surface - that is clear and open - with engine off and parking brake set.
2. Disengage transmission by placing freewheel control in freewheeling position (See "TO TRANSPORT" in this section of manual).
3. Sitting in the tractor seat, start engine. After the engine is running, move throttle control to slow position. Disengage parking brake



CAUTION: At any time, during step 4, there may be movement of the drive wheels.

4. Depress forward drive pedal to full forward position, hold for five (5) seconds and release pedal. Depress reverse drive pedal to full reverse position, hold for five (5) seconds and release pedal. Repeat this procedure three (3) times.
5. Shut- off engine and set parking brake.
6. Engage transmission by placing freewheel control in engaged position (See "TO TRANSPORT" in this section of manual).
7. Sitting in the tractor seat, start engine. After the engine is running, move throttle control to half (1/2) speed. Disengage parking brake.

8. Drive tractor forward for approximately five feet then backwards for five feet. Repeat this driving procedure three times.

Your transmission is now purged and now ready for normal operation.

MOWING TIPS

- Mower should be properly leveled for best mowing performance. See "TO LEVEL MOWER HOUSING" in the Service and Adjustments section of this manual.
- The left hand side of mower should be used for trimming.
- Drive so that clippings are discharged onto the area that has been cut. Have the cut area to the right of the machine. This will result in a more even distribution of clippings and more uniform cutting.
- When mowing large areas, start by turning to the right so that clippings will discharge away from shrubs, fences, driveways, etc. After one or two rounds, mow in the opposite direction making left hand turns until finished (See Fig. 26).

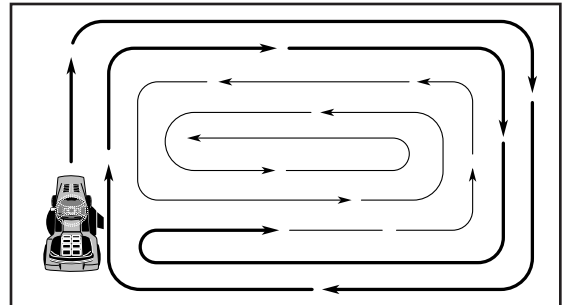

Fig. 26

- If grass is extremely tall, it should be mowed twice to reduce load and possible fire hazard from dried clippings. Make first cut relatively high; the second to the desired height.
- Do not mow grass when it is wet. Wet grass will plug mower and leave undesirable clumps. Allow grass to dry before mowing.
- **Always operate engine at full throttle when mowing** to assure better mowing performance and proper discharge of material. Regulate ground speed by selecting a low enough gear to give the mower cutting performance as well as the quality of cut desired.
- When operating attachments, select a ground speed that will suit the terrain and give best performance of the attachment being used.

MAINTENANCE

MAINTENANCE SCHEDULE		BEFORE EACH USE	EVERY 8 HOURS	EVERY 25 HOURS	EVERY 50 HOURS	EVERY 100 HOURS	EVERY SEASON	BEFORE STORAGE
TRACTOR	Check Brake Operation	✓	✓					
	Check Tire Pressure	✓	✓					
	Check Operator Presence & ROS Systems	✓						
	Check for Loose Fasteners	✓				✓		✓
	Check/Replace Mower Blades			✓ ³				
	Lubrication Chart			✓				✓
	Check Battery Level			✓ ⁴				
	Clean Battery and Terminals			✓				✓
	Clean Debris Off Steering Plate			✓ ⁵				
	Check Transaxle Cooling			✓				
	Check Mower Levelness				✓			
	Check V-Belts					✓		
ENGINE	Check Engine Oil Level	✓	✓					
	Change Engine Oil (with oil filter)				✓ ^{1,2}			✓
	Change Engine Oil (without oil filter)			✓ ^{1,2}				✓
	Clean Air Filter			✓ ²				
	Clean Air Screen			✓ ²				
	Inspect Muffler/Spark Arrester				✓			
	Replace Oil Filter (If equipped)					✓ ^{1,2}		
	Clean Engine Cooling Fins					✓ ²		
	Replace Spark Plug					✓	✓	
	Replace Air Filter Paper Cartridge					✓ ²		
	Replace Fuel Filter						✓	

1 - Change more often when operating under a heavy load or in high ambient temperatures.
2 - Service more often when operating in dirty or dusty conditions.

3 - Replace blades more often when mowing in sandy soil.
4 - Not required if equipped with maintenance-free battery.

5 - See Cleaning in Maintenance Section.

GENERAL RECOMMENDATIONS

The warranty on this tractor does not cover items that have been subjected to operator abuse or negligence. To receive full value from the warranty, operator must maintain tractor as instructed in this manual.

Some adjustments will need to be made periodically to properly maintain your tractor.

At least once a season, check to see if you should make any of the adjustments described in the Service and Adjustments section of this manual.

- At least once a year you should replace the spark plug, clean or replace air filter, and check blades and belts for wear. A new spark plug and clean air filter assure proper air-fuel mixture and help your engine run better and last longer.

BEFORE EACH USE

- Check engine oil level.
- Check brake operation.
- Check tire pressure.
- Check operator presence and ROS systems for proper operation.
- Check for loose fasteners.

LUBRICATION CHART

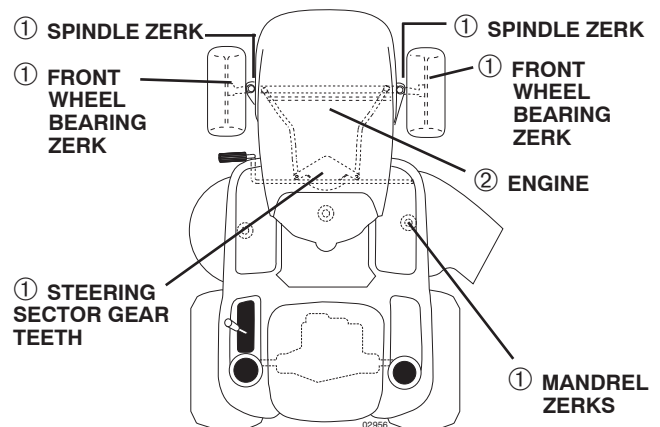

- ① General Purpose Grease
- ② Refer to Maintenance "ENGINE" Section

IMPORTANT: DO NOT OIL OR GREASE THE PIVOT POINTS WHICH HAVE SPECIAL NYLON BEARINGS. VISCOUS LUBRICANTS WILL ATTRACT DUST AND DIRT THAT WILL SHORTEN THE LIFE OF THE SELF-LUBRICATING BEARINGS. IF YOU FEEL THEY MUST BE LUBRICATED, USE ONLY A DRY, POWDERED GRAPHITE TYPE LUBRICANT SPARINGLY.

MAINTENANCE

TRACTOR

Always observe safety rules when performing any maintenance.

BRAKE OPERATION

If tractor requires more than five (5) feet to stop at highest speed in highest gear on a level, dry concrete or paved surface, then brake must be serviced. (See "TO CHECK BRAKE" in the Service and Adjustments section of this manual).

TIRES

- Maintain proper air pressure in all tires (See PSI on tires).
- Keep tires free of gasoline, oil, or insect control chemicals which can harm rubber.
- Avoid stumps, stones, deep ruts, sharp objects and other hazards that may cause tire damage.

NOTE: To seal tire punctures and prevent flat tires due to slow leaks, tire sealant may be purchased from your local parts dealer. Tire sealant also prevents tire dry rot and corrosion.

OPERATOR PRESENCE SYSTEM AND REVERSE OPERATION SYSTEM (ROS)

Be sure operator presence and reverse operation systems are working properly. If your tractor does not function as described, repair the problem immediately.

- The engine should not start unless the brake pedal is fully depressed, and the attachment clutch control is in the disengaged position.

CHECK OPERATOR PRESENCE SYSTEM

- When the engine is running, any attempt by the operator to leave the seat without first setting the parking brake should shut off the engine.
- When the engine is running and the attachment clutch is engaged, any attempt by the operator to leave the seat should shut off the engine.
- The attachment clutch should never operate unless the operator is in the seat.

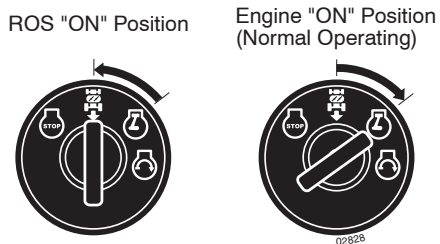

CHECK REVERSE OPERATION (ROS) SYSTEM

- When the engine is running with the ignition switch in the engine "ON" position and the attachment clutch engaged, any attempt by the operator to shift into reverse should shut off the engine.
- When the engine is running with the ignition switch in the ROS "ON" position and the attachment clutch engaged, any attempt by the operator to shift into reverse should NOT shut off the engine.

BLADE CARE

For best results mower blades must be sharp. Replace worn, bent or damaged blades.



CAUTION: Use only a replacement blade approved by the manufacturer of your tractor. Using a blade not approved by the manufacturer of your tractor is hazardous, could damage your tractor and void your warranty.

BLADE REMOVAL (See Fig. 27)

- Raise mower to highest position to allow access to blades.

NOTE: Protect your hands with gloves and/or wrap blade with heavy cloth.

- Remove blade bolt by turning counterclockwise.
- Install new blade with stamped "GRASS SIDE" facing the ground.

IMPORTANT: To ensure proper assembly, center hole in blade must align with star on mandrel assembly.

- Install and tighten blade bolt securely (45-55 Ft. Lbs. torque).

IMPORTANT: Special blade bolt is heat treated.

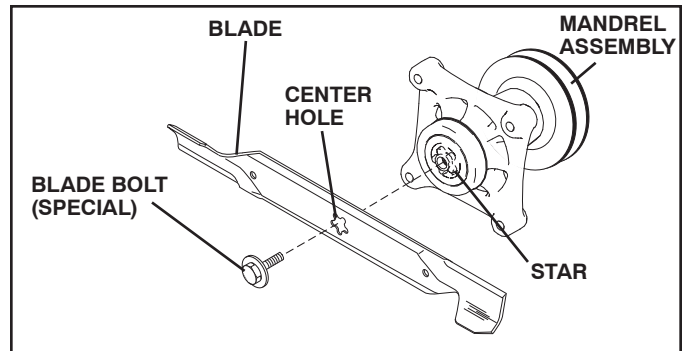

Fig. 27

BATTERY

Your tractor has a battery charging system which is sufficient for normal use. However, periodic charging of the battery with an automotive charger will extend its life.

- Keep battery and terminals clean.
- Keep battery bolts tight.
- Keep small vent holes open.
- Recharge at 6-10 amperes for 1 hour.

NOTE: The original equipment battery on your tractor is maintenance free. Do not attempt to open or remove caps or covers. Adding or checking level of electrolyte is not necessary.

TO CLEAN BATTERY AND TERMINALS

Corrosion and dirt on the battery and terminals can cause the battery to "leak" power.

- Remove terminal guard.
- Disconnect BLACK battery cable first then RED battery cable and remove battery from tractor.

MAINTENANCE

- Rinse the battery with plain water and dry.
- Clean terminals and battery cable ends with wire brush until bright.
- Coat terminals with grease or petroleum jelly.
- Reinstall battery (See "REPLACING BATTERY" in the SERVICE AND ADJUSTMENTS section of this manual).

V-BELTS

Check V-belts for deterioration and wear after 100 hours of operation and replace if necessary. The belts are not adjustable. Replace belts if they begin to slip from wear.

TRANSAXLE COOLING

The transmission fan and cooling fins should be kept clean to assure proper cooling.

Do not attempt to clean fan or transmission while engine is running or while the transmission is hot. To prevent possible damage to seals, do not use high pressure water or steam to clean transaxle.

- Inspect cooling fan to be sure fan blades are intact and clean.
- Inspect cooling fins for dirt, grass clippings and other materials. To prevent damage to seals, do not use compressed air or high pressure sprayer to clean cooling fins.

TRANSAXLE PUMP FLUID

The transaxle was sealed at the factory and fluid maintenance is not required for the life of the transaxle. Should the transaxle ever leak or require servicing, contact your nearest authorized service center/department.

ENGINE

LUBRICATION

Only use high quality detergent oil rated with API service classification SG-SL. Select the oil's SAE viscosity grade according to your expected operating temperature. When operating in temperatures below 0° F (-18° C) synthetic oil must be used.

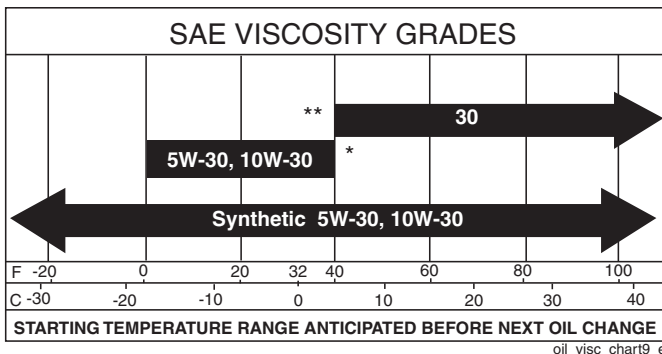

*** CAUTION:** Air cooled engines run hotter than automotive engines. The use of non-synthetic multi-viscosity oils (5W30, 10W30 etc.) in temperatures above 40° F (4° C) will result in higher than normal oil consumption. When using a multi-viscosity oil, check oil level more frequently.

**** CAUTION:** SAE 30 oil, if used below 40° F (4° C), will result in hard starting and possible engine bore damage due to inadequate lubrication.



NOTE: Synthetic oil meeting ILSAC GF-2, API certification mark and API service symbol (shown at left) with "SJ/CF ENERGY CONSERVING" or higher, is an acceptable oil at all temperatures. **Use of synthetic oil does not alter required oil change intervals.**

Change the oil after every 50 hours of operation or at least once a year if the tractor is not used for 50 hours in one year.

Check the crankcase oil level before starting the engine and after each eight (8) hours of operation. Tighten oil fill cap/dipstick securely each time you check the oil level.

TO CHANGE ENGINE OIL (See Fig. 28)

Determine temperature range expected before oil change. All oil must meet API service classification SG-SL.

- Be sure tractor is on level surface.
- Oil will drain more freely when warm.
- Catch oil in a suitable container.
- Remove oil fill cap/dipstick. Be careful not to allow dirt to enter the engine when changing oil.
- Remove yellow cap from end of drain valve and install the drain tube onto the fitting.

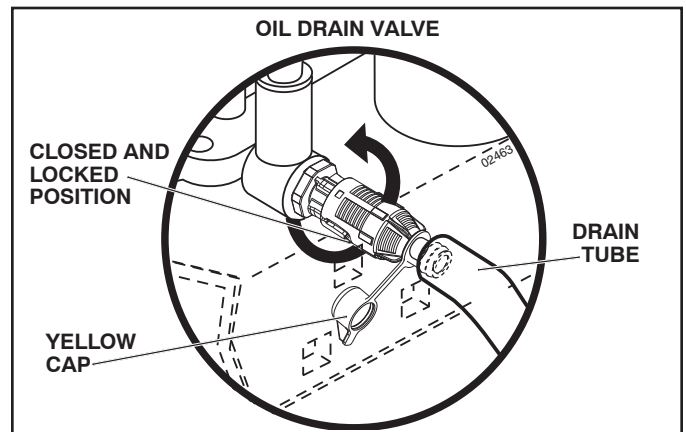

Fig. 28

- Unlock drain valve by pushing inward and turning counterclockwise.
- To open, pull out on the drain valve.
- After oil has drained completely, close and lock the drain valve by pushing inward and turning clockwise until the pin is in the locked position as shown.
- Remove the drain tube and replace the cap onto to the bottom fitting of the drain valve.
- Refill engine with oil through oil fill dipstick tube. Pour slowly. Do not overfill. For approximate capacity see "PRODUCT SPECIFICATIONS" section of this manual.
- Use gauge on oil fill cap/dipstick for checking level. Ensure dipstick cap is tightened securely for accurate reading. Keep oil at "FULL" line on dipstick. Tighten cap onto the tube securely when finished.

ENGINE OIL FILTER

Replace the engine oil filter every season or every other oil change if the tractor is used more than 100 hours in one year.

MAINTENANCE

CLEAN AIR SCREEN

Air screen must be kept free of dirt and chaff to prevent engine damage from overheating. Clean with a wire brush or compressed air to remove dirt and stubborn dried gum fibers.

AIR FILTER (See Fig. 29)

Your engine will not run properly using a dirty air filter. Clean the foam pre-cleaner after every 25 hours of operation or every season. Service paper cartridge every 100 hours of operation or every season, whichever occurs first.

Service air cleaner more often under dusty conditions.

- Remove cover.

TO SERVICE PRE-CLEANER

- Wash it in liquid detergent and water.
- Squeeze it dry in a clean cloth.
- Saturate it in engine oil. Wrap it in clean, absorbent cloth and squeeze to remove excess oil.
- If very dirty or damaged, replace pre-cleaner.

TO SERVICE CARTRIDGE

- Clean cartridge by tapping gently on flat surface. If very dirty or damaged, replace cartridge.
- Reinstall precleaner cartridge, cover and secure.

IMPORTANT: PETROLEUM SOLVENTS, SUCH AS KEROSENE, ARE NOT TO BE USED TO CLEAN THE CARTRIDGE. THEY MAY CAUSE DETERIORATION OF THE CARTRIDGE. DO NOT OIL CARTRIDGE. DO NOT USE PRESSURIZED AIR TO CLEAN OR DRY CARTRIDGE.

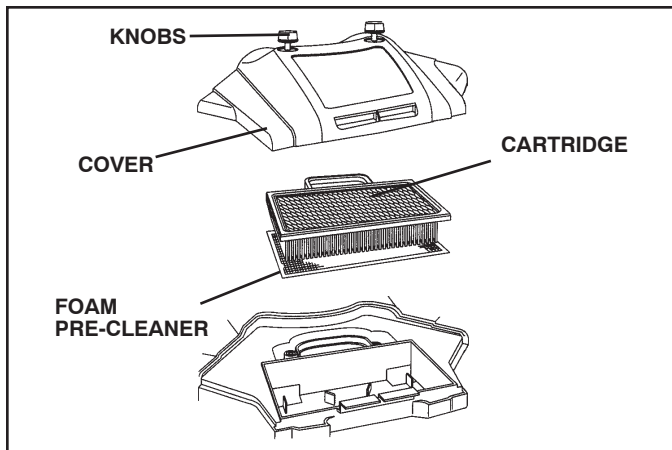

Fig. 29

ENGINE COOLING SYSTEM

To ensure proper cooling, make sure the grass screen, cooling fins, and other external surfaces of the engine are kept clean at all times.

Every 100 hours of operation (more often under extremely dusty, dirty conditions), remove the blower housing and other cooling shrouds. Clean the cooling fins and external surfaces as necessary. Ensure the cooling shrouds are reinstalled.

NOTE: Operating the engine with a blocked grass screen, dirty or plugged cooling fins, and/or cooling shrouds removed will cause engine damage due to overheating.

MUFFLER

Inspect and replace corroded muffler and spark arrester (if equipped) as it could create a fire hazard and/or damage.

SPARK PLUGS

Replace spark plugs at the beginning of each mowing season or after every 100 hours of operation, whichever occurs first. Spark plug type and gap setting are shown in "PRODUCT SPECIFICATIONS" section of this manual.

IN-LINE FUEL FILTER (See Fig. 30)

The fuel filter should be replaced once each season. If fuel filter becomes clogged, obstructing fuel flow to carburetor, replacement is required.

- With engine cool, remove filter and plug fuel line sections.
- Place new fuel filter in position in fuel line with arrow pointing towards carburetor.
- Be sure there are no fuel line leaks and clamps are properly positioned.
- Immediately wipe up any spilled gasoline.

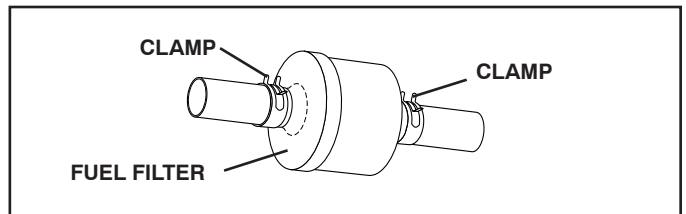

Fig. 30

CLEANING

- Clean engine, battery, seat, finish, etc. of all foreign matter.
- Clean debris from steering plate. Debris can restrict clutch/brake pedal movement, causing belt slip and loss of drive.



CAUTION: Avoid all pinch points and movable parts (See Fig. 31)

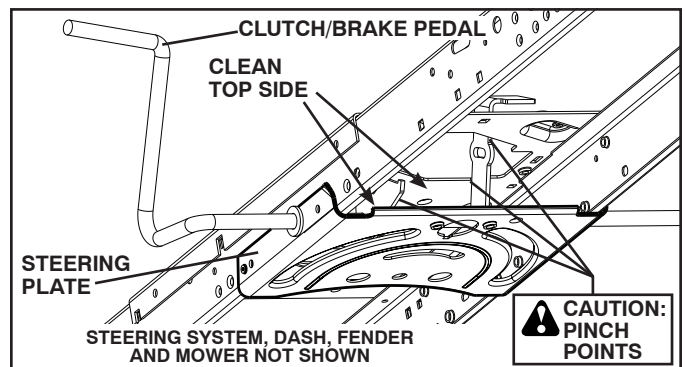

Fig. 31

- Keep finished surfaces and wheels free of all gasoline, oil, etc.
- Protect painted surfaces with automotive type wax.

We do not recommend using a garden hose or pressure washer to clean your tractor unless the engine and transmission are covered to keep water out. Water in engine or transmission will shorten the useful life of your tractor. Use compressed air or a leaf blower to remove grass, leaves and trash from tractor and mower.

MAINTENANCE

DECK WASHOUT PORT (See Fig. 32)

Your tractor's deck is equipped with a washout port on its surface as part of its deck wash system. It should be utilized after each use.

1. Drive the tractor to a level, clear spot on your lawn, near enough to a water spigot for your garden hose to reach.

IMPORTANT: Make certain the tractor's discharge chute is directed AWAY from your house, garage, parked cars, etc. Remove bagger chute or mulch cover if attached.

2. Make sure the attachment clutch control is in the "DISENGAGED" position, set the parking brake, and stop the engine.
3. Thread the nozzle adapter (packaged with your tractor's Operator's Manual) onto the end of your garden hose.
4. Pull back the lock collar of the nozzle adapter and push the adapter onto the deck washout port at the left end of the mower deck. Release the lock collar to lock the adapter on the nozzle.

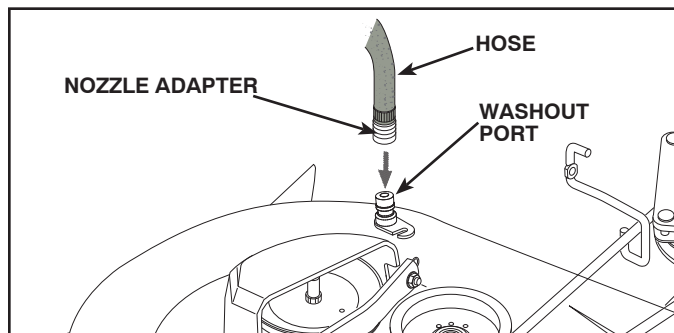

Fig. 32

IMPORTANT: Tug hose ensuring connection is secure.

5. Turn the water on.
6. While sitting in the operator's position on the tractor, re-start the engine and place the throttle lever in the Fast "👉" position.

IMPORTANT: Recheck the area making certain the area is clear.

7. Move the tractor's attachment clutch control to the "ENGAGED" position. Remain in the operator's position with the cutting deck engaged until the deck is cleaned.
8. Move the tractor's attachment clutch control to the "DISENGAGED" position. Turn the ignition key to the STOP position to turn the tractor's engine off. Turn the water off.
9. Pull back the lock collar of the nozzle adapter to disconnect the adapter from the nozzle washout port.
10. Move the tractor to a dry area, preferably a concrete or paved area. Place the attachment clutch control in the "ENGAGED" position to remove excess water and to help dry before putting the tractor away.



WARNING: A broken or missing washout fitting could expose you or others to thrown objects from contact with the blade.

- Replace broken or missing washout fitting immediately, prior to using mower again.
- Plug any holes in mower with bolts and locknuts.

SERVICE AND ADJUSTMENTS



WARNING: TO AVOID SERIOUS INJURY, BEFORE PERFORMING ANY SERVICE OR ADJUSTMENTS:

- Depress brake pedal fully and set parking brake.
- Place attachment clutch in “DISENGAGED” position.
- Turn ignition key to “STOP” and remove key.
- Make sure the blades and all moving parts have completely stopped.
- Disconnect spark plug wire from spark plug and place wire where it cannot come in contact with plug.

TO REMOVE MOWER (See Fig. 33)

- Place attachment clutch in “DISENGAGED” position.
- Lower attachment lift to its lowest position.
- Disengage belt tension rod (K) from lock bracket (L).



CAUTION: Belt tension rod is spring loaded. Have a tight grip on rod and release slowly.

- Remove mower belt from electric clutch pulley (M).
- Disconnect front link (E) from mower - remove retainer spring and washer.
- Go to either side of mower and disconnect mower suspension arm (A) from chassis and rear lift link (C) from rear mower bracket (D) - remove retainers springs and washers.
- Go to other side of mower and disconnect the suspension arm and rear lift link.



CAUTION: After rear lift links are disconnected, the attachment lift lever will be spring loaded. Have a tight grip on lift lever when changing position of the lever.

- From right side of mower, disconnect anti-sway bar (S) from right rear mower bracket (D) - remove retainer spring and washer and pull mower toward you until the bar falls from the hole in bracket.
- Turn tractor steering wheel to the left as far as it will go.
- Slide mower out from under right side of tractor.

TO INSTALL MOWER

Follow procedure described in “INSTALL MOWER AND DRIVE BELT” in the Assembly section of this manual.

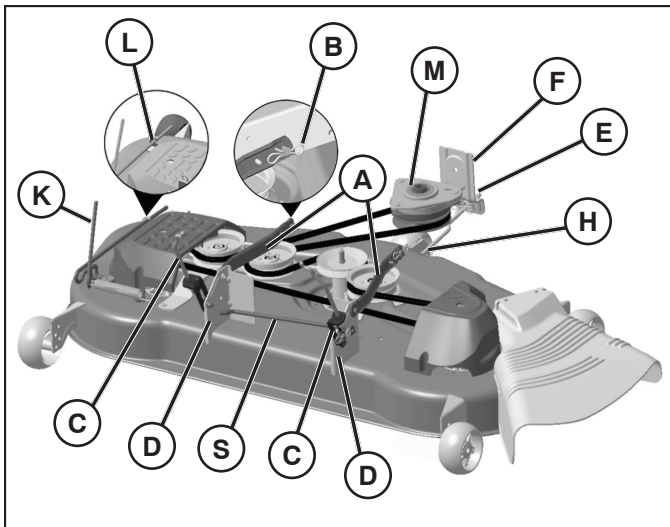

Fig. 33

TO REPLACE MOWER BLADE DRIVE BELT (See Fig. 34)

MOWER DRIVE BELT REMOVAL

- Park tractor on a level surface. Engage parking brake.
- Lower attachment lift to its lowest position.
- Disengage belt tension rod (K) from lock bracket (L).



CAUTION: Belt tension rod is spring loaded. Have a firm grip on rod and release slowly.

- Remove screws (P) from mandrel covers (Q) and remove covers.
- Remove any dirt or grass clippings which may have accumulated around mandrels and entire upper deck surface.
- Remove belt from electric clutch pulley (M), both mandrel pulleys (R) and all idler pulleys (V).

MOWER DRIVE BELT INSTALLATION

- Install belt around all mandrel pulleys (R) and around idler pulleys (V) as shown.
- Install belt onto electric clutch pulley (M).

IMPORTANT: Check belt for proper routing in all mower pulley grooves.

- Reassemble mandrel covers (Q). Securely tighten all screws.
- Engage belt tension rod (K) on locking bracket (L).



CAUTION: Belt tension rod is spring loaded. Have a tight grip on rod and engage slowly.

- Raise attachment lift to highest position.

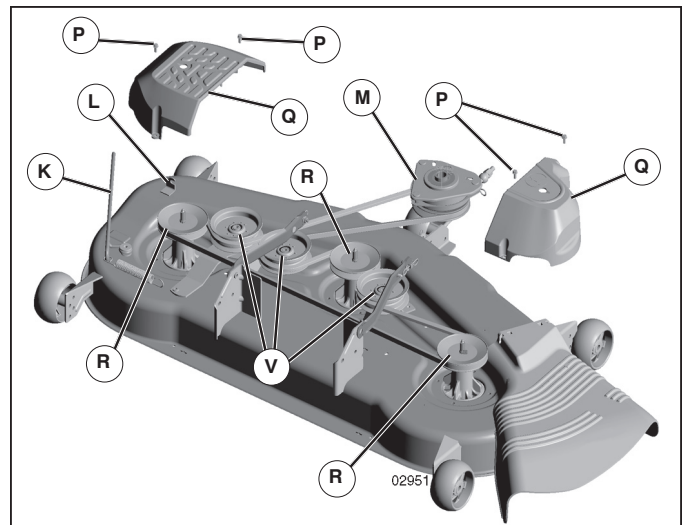

Fig. 34

SERVICE AND ADJUSTMENTS

TO LEVEL MOWER

Make sure tires are properly inflated to the PSI shown on tires. If tires are over or under inflated, it may affect the appearance of your lawn and lead you to think the mower is not adjusted properly.

VISUAL SIDE-TO-SIDE ADJUSTMENT (See Fig. 35)

- With all tires properly inflated and if your lawn appears unevenly cut, determine which side of mower is cutting lower.

NOTE: As desired, you can raise the low side of mower or lower the high side.

- Go to side of mower you wish to adjust.
- With a 3/4" or adjustable wrench, turn lift link adjustment nut (A) to the left to lower the mower, or to the right to raise the mower.

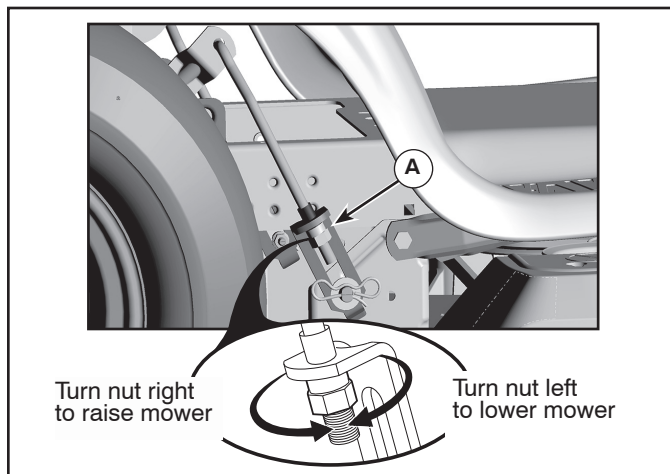

Fig. 35

NOTE: Each full turn of adjustment nut will change mower height about 3/16".

- Test your adjustment by mowing some uncut grass and visually checking the appearance. Readjust, if necessary, until you are satisfied with the results.

PRECISION SIDE-TO-SIDE ADJUSTMENT (See Fig. 36)

- With all tires properly inflated, park tractor on level ground or driveway.



Fig. 36

- If adjustment is necessary, see steps in Visual Adjustment instructions above.
- Recheck measurements, adjust if necessary until both sides are equal.

FRONT-TO-BACK ADJUSTMENT (See Figs. 37 & 38)

IMPORTANT: Deck must be level side-to-side.

To obtain the best cutting results, the mower blades should be adjusted so the front tip is 1/8" to 1/2" lower than the rear tip when the mower is in its highest position.



- Raise mower to highest position.
- Position any blade so the tip is pointing straight forward. Measure distance (B) to the ground at front and rear tip of the blade.

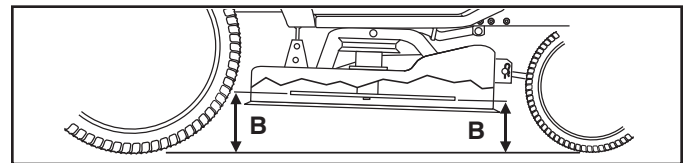

Fig. 37

- If front tip of blade is not 1/8" to 1/2" lower than the rear tip, go to the front of tractor.
- With an 11/16" or adjustable wrench, loosen jam nut A several turns to clear adjustment nut B.
- With a 3/4" or adjustable wrench, turn front link adjustment nut (B) clockwise (tighten) to raise the front of mower, or, counterclockwise (loosen) to lower the front mower.

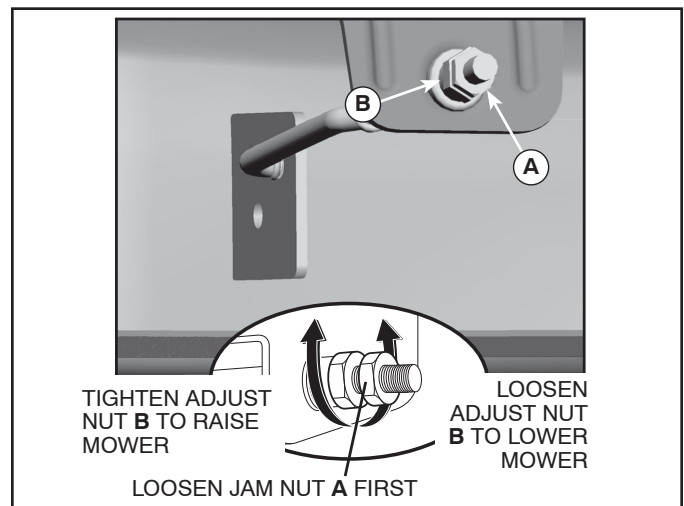

Fig. 38

NOTE: Each full turn of the adjustment nut will change mower height about 1/8".

- Recheck measurements, adjust if necessary until front tip of blade is 1/8" to 1/2" lower than the rear tip.
- Hold adjustment nut in position with wrench and tighten jam nut securely against adjustment nut.

SERVICE AND ADJUSTMENTS

TO CHECK BRAKE

If tractor requires more than five (5) feet to stop at highest speed in highest gear on a level, dry concrete or paved surface, then brake must be serviced.

You may also check brake by:

- Park tractor on a level, dry concrete or paved surface, depress brake pedal all the way down and engage parking brake.
- Disengage transmission by placing freewheel control in "transmission disengaged" position. Pull freewheel control out and into the slot and release so it is held in the disengaged position.

The rear wheels must lock and skid when you try to manually push the tractor forward. If the rear wheels rotate, then the brake needs to be serviced. Contact a qualified service center.

TO REPLACE MOTION DRIVE BELT (See Fig. 39)

Park the tractor on level surface. Engage parking brake. For assistance, there is a belt installation guide decal on bottom side of left footrest.

BELT REMOVAL -

- Remove mower (See "TO REMOVE MOWER" in this section of manual).

NOTE: Observe entire motion drive belt and position of all belt guides and keepers.

- Disconnect clutch wire harness (A).
- Remove anti-rotation link (B) on right side of tractor.
- Remove belt from stationary idler (C) and clutching idler (D).
- Remove belt from centerspan idler (E).
- Pull belt slack toward rear of tractor. Carefully remove belt upwards from transmission input pulley and over cooling fan blades (F).
- Remove belt downward from engine pulley and around electric clutch (G).
- Slide belt toward rear of tractor, off the steering plate (H) and remove from tractor.

BELT INSTALLATION -

- Install new belt from tractor rear to front, over the steering plate (H) and above clutch brake pedal shaft (J).
- Pull belt toward front of tractor and roll belt around electric clutch and onto engine pulley (G).
- Pull belt toward rear of tractor. Carefully work belt down around transmission cooling fan and onto the input pulley (F). Be sure belt is inside the belt keeper.
- Install belt on centerspan idler (E).
- Install belt through stationary idler (C) and clutching idler (D).
- Reinstall anti-rotation link (B) on right side of tractor. Tighten securely.
- Reconnect clutch harness (A).
- Make sure belt is in all pulley grooves and inside all belt guides and keepers.
- Install mower (See "TO INSTALL MOWER" in this section of manual).

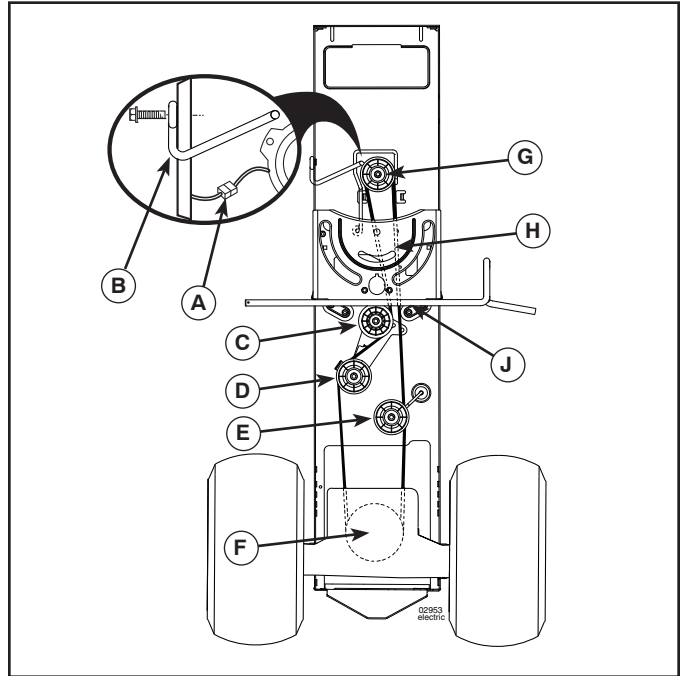

Fig. 39

FRONT WHEEL TOE-IN/CAMBER

Your new tractor front wheel toe-in and camber is set at the factory and is normal. The front wheel toe-in and camber are not adjustable. If damage has occurred to affect the factory set front wheel toe-in or camber, contact a qualified service center.

TO REMOVE WHEEL FOR REPAIRS (See Fig. 40)

- Block up axle securely.
- Remove axle cover, retaining ring and washers to allow wheel removal (rear wheel contains a square key - Do not lose).
- Repair tire and reassemble.
- On rear wheels only: align grooves in rear wheel hub and axle. Insert square key.
- Replace washers and snap retaining ring securely in axle groove.
- Replace axle cover.

NOTE: To seal tire punctures and prevent flat tires due to slow leaks, tire sealant may be purchased from your local parts dealer. Tire sealant also prevents tire dry rot and corrosion.

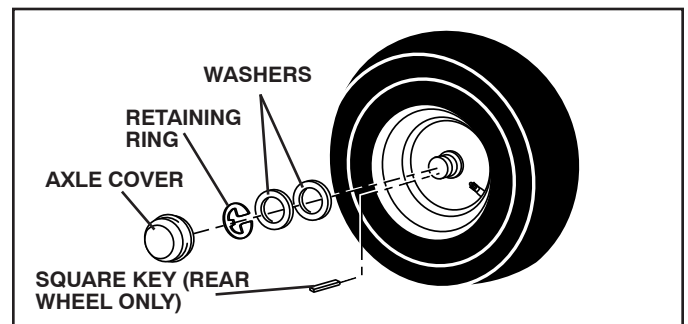

Fig. 40

SERVICE AND ADJUSTMENTS

TO START ENGINE WITH A WEAK BATTERY (See Fig. 41)



WARNING: Lead-acid batteries generate explosive gases. Keep sparks, flame and smoking materials away from batteries. Always wear eye protection when around batteries.

If your battery is too weak to start the engine, it should be recharged. (See "BATTERY" in the MAINTENANCE section of this manual).

If "jumper cables" are used for emergency starting, follow this procedure:

IMPORTANT: YOUR TRACTOR IS EQUIPPED WITH A 12 VOLT SYSTEM. THE OTHER VEHICLE MUST ALSO BE A 12 VOLT SYSTEM. DO NOT USE YOUR TRACTOR BATTERY TO START OTHER VEHICLES.

TO ATTACH JUMPER CABLES -

- Connect one end of the RED cable to the POSITIVE (+) terminal of each battery(A-B), taking care not to short against tractor chassis.
- Connect one end of the BLACK cable to the NEGATIVE (-) terminal (C) of fully charged battery.
- Connect the other end of the BLACK cable (D) to good chassis ground, away from fuel tank and battery.

TO REMOVE CABLES, REVERSE ORDER -

- BLACK cable first from chassis and then from the fully charged battery.
- RED cable last from both batteries.

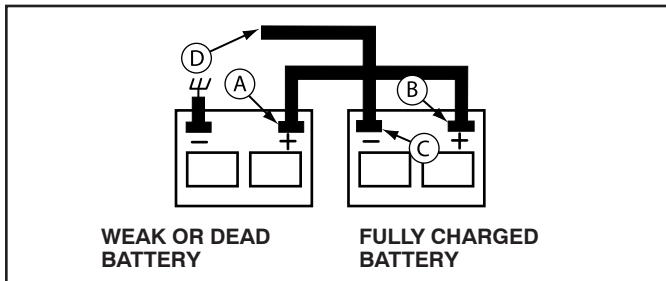

Fig. 41

REPLACING BATTERY (See Fig. 42)



WARNING: Do not short battery terminals by allowing a wrench or any other object to contact both terminals at the same time. Before connecting battery, remove metal bracelets, wristwatch bands, rings, etc. Positive terminal must be connected first to prevent sparking from accidental grounding.

- Lift hood to raised position.
- Remove terminal cover.
- Disconnect BLACK battery cable then RED battery cable and carefully remove battery from tractor.
- Install new battery with terminals in same position as old battery.
- Reinstall terminal cover.

- First connect RED battery cable to positive (+) battery terminal with bolt and nut as shown. Tighten securely.
- Connect BLACK grounding cable to negative (-) battery terminal with remaining bolt and nut. Tighten securely
- Close hood.

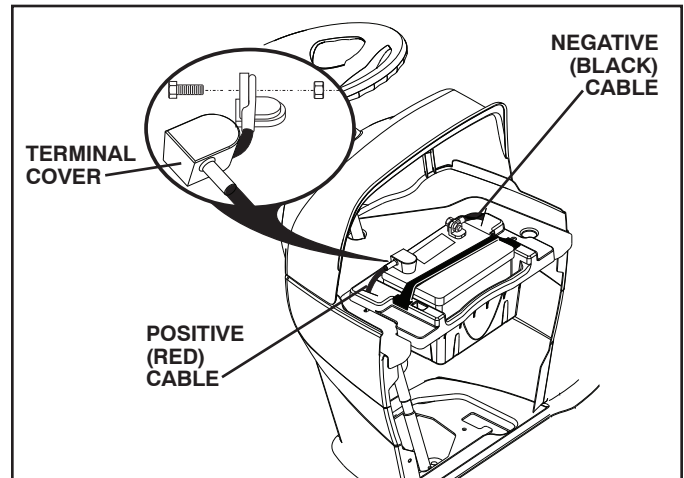

Fig. 42

TO REPLACE HEADLIGHT BULB

- Raise hood.
- Pull bulb holder out of the hole in the backside of the grill.
- Replace bulb in holder and push bulb holder securely back into the hole in the backside of the grill.
- Close hood.

INTERLOCKS AND RELAYS

Loose or damaged wiring may cause your tractor to run poorly, stop running, or prevent it from starting.

- Check wiring. See electrical wiring diagram in the Repair Parts section.

TO REPLACE FUSE

Replace with 20 amp automotive-type plug-in fuse. The fuse holder is located behind the dash.

SERVICE AND ADJUSTMENTS

TO REMOVE HOOD AND GRILL ASSEMBLY (See Fig. 43)

- Raise hood.
- Unsnap headlight wire connector.
- Stand in front of tractor. Grasp hood at sides, tilt toward engine and lift off of tractor.
- To replace, reverse above procedure.

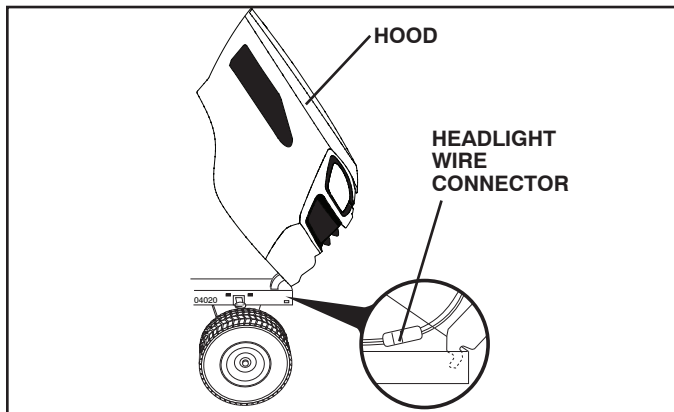

Fig. 43

ENGINE

TO ADJUST THROTTLE CONTROL CABLE

The throttle control has been preset at the factory and adjustment should not be necessary. If adjustment is necessary, see engine manual.

TO ADJUST CHOKE CONTROL

The choke control has been preset at the factory and adjustment should not be necessary. If adjustment is necessary, see engine manual.

TO ADJUST CARBURETOR

Your carburetor is not adjustable. If your engine does not operate properly due to suspected carburetor problems, take your tractor to an authorized service center for repair and/or adjustment.

TRANSMISSION

REMOVAL/REPLACEMENT

Should your transmission require removal for service or replacement, it should be purged after reinstallation and before operating the tractor. See "PURGE TRANSMISSION" in the Operation section of this manual.

STORAGE

Immediately prepare your tractor for storage at the end of the season or if the tractor will not be used for 30 days or more.



WARNING: Never store the tractor with gasoline in the tank inside a building where fumes may reach an open flame or spark. Allow the engine to cool before storing in any enclosure.

TRACTOR

Remove mower from tractor for winter storage. When mower is to be stored for a period of time, clean it thoroughly, remove all dirt, grease, leaves, etc. Store in a clean, dry area.

- Clean entire tractor (See “CLEANING” in the Maintenance section of this manual).
- Inspect and replace belts, if necessary (See belt replacement instructions in the Service and Adjustments section of this manual).
- Lubricate as shown in the Maintenance section of this manual.
- Be sure that all nuts, bolts and screws are securely fastened. Inspect moving parts for damage, breakage and wear. Replace if necessary.
- Touch up all rusted or chipped paint surfaces; sand lightly before painting.

BATTERY

- Fully charge the battery for storage.
- After a period of time in storage, battery may require recharging.
- To help prevent corrosion and power leakage during long periods of storage, battery cables should be disconnected and battery cleaned thoroughly (see “TO CLEAN BATTERY AND TERMINALS” in the Maintenance section of this manual).
- After cleaning, leave cables disconnected and place cables where they cannot come in contact with battery terminals.
- If battery is removed from tractor for storage, do not store battery directly on concrete or damp surfaces.

ENGINE

FUEL SYSTEM

IMPORTANT: IT IS IMPORTANT TO PREVENT GUM DEPOSITS FROM FORMING IN ESSENTIAL FUEL SYSTEM PARTS SUCH AS CARBURETOR, FUEL FILTER, FUEL HOSE, OR TANK DURING STORAGE. ALSO, EXPERIENCE INDICATES THAT ALCOHOL BLENDED FUELS (CALLED GASOHOL OR USING ETHANOL OR METHANOL) CAN ATTRACT MOISTURE WHICH LEADS TO SEPARATION AND FORMATION OF ACIDS DURING STORAGE. ACIDIC GAS CAN DAMAGE THE FUEL SYSTEM OF AN ENGINE WHILE IN STORAGE.

- Empty the fuel tank by starting the engine and let it run until the fuel lines and carburetor are empty.
- Never use engine or carburetor cleaner products in the fuel tank or permanent damage may occur.
- Use fresh fuel next season.

NOTE: Fuel stabilizer is an acceptable alternative in minimizing the formation of fuel gum deposits during storage. Add stabilizer to gasoline in fuel tank or storage container. Always follow the mix ratio found on stabilizer container. Run engine at least 10 minutes after adding stabilizer to allow the stabilizer to reach the carburetor. Do not empty the gas tank and carburetor if using fuel stabilizer.

ENGINE OIL

Drain oil (with engine warm) and replace with clean engine oil. (See “ENGINE” in the Maintenance section of this manual).

CYLINDER(S)

- Remove spark plug(s).
- Pour one ounce of oil through spark plug hole(s) into cylinder(s).
- Turn ignition key to “START” position for a few seconds to distribute oil.
- Replace with new spark plug(s).

OTHER

- Do not store gasoline from one season to another.
- Replace your gasoline can if your can starts to rust. Rust and/or dirt in your gasoline will cause problems.
- If possible, store your tractor indoors and cover it to give protection from dust and dirt.
- Cover your tractor with a suitable protective cover that does not retain moisture. Do not use plastic. Plastic cannot breathe which allows condensation to form and will cause your tractor to rust.

IMPORTANT: NEVER COVER TRACTOR WHILE ENGINE AND EXHAUST AREAS ARE STILL WARM.

TROUBLESHOOTING POINTS

PROBLEM	CAUSE	CORRECTION
Will not start	<ol style="list-style-type: none"> 1. Out of fuel. 2. Engine not "CHOKED" properly. 3. Engine flooded. 4. Bad spark plug. 5. Dirty air filter. 6. Dirty fuel filter. 7. Water in fuel. 8. Loose or damaged wiring. 9. Carburetor out of adjustment. 10. Engine valves out of adjustment. 	<ol style="list-style-type: none"> 1. Fill fuel tank. 2. See "TO START ENGINE" in Operation section. 3. Wait several minutes before attempting to start. 4. Replace spark plug. 5. Clean/replace air filter. 6. Replace fuel filter. 7. Empty fuel tank and carburetor, refill tank with fresh gasoline and replace fuel filter. 8. Check all wiring. 9. See "To Adjust Carburetor" in Service Adjustments section. 10. Contact an authorized service center/department.
Hard to start	<ol style="list-style-type: none"> 1. Dirty air filter. 2. Bad spark plug. 3. Weak or dead battery. 4. Dirty fuel filter. 5. Stale or dirty fuel. 6. Loose or damaged wiring. 7. Carburetor out of adjustment. 8. Engine valves out of adjustment. 	<ol style="list-style-type: none"> 1. Clean/replace air filter. 2. Replace spark plug. 3. Recharge or replace battery. 4. Replace fuel filter. 5. Empty fuel tank and refill tank with fresh, clean gas. 6. Check all wiring. 7. See "To Adjust Carburetor" in Service Adjustments section. 8. Contact an authorized service center/department.
Engine will not turn over	<ol style="list-style-type: none"> 1. Brake pedal not depressed. 2. Attachment clutch is engaged. 3. Weak or dead battery. 4. Blown fuse. 5. Corroded battery terminals. 6. Loose or damaged wiring. 7. Faulty ignition switch. 8. Faulty solenoid or starter. 9. Faulty operator presence switch(es). 	<ol style="list-style-type: none"> 1. Depress brake pedal. 2. Disengage attachment clutch. 3. Recharge or replace battery. 4. Replace fuse. 5. Clean battery terminals. 6. Check all wiring. 7. Check/replace ignition switch. 8. Check/replace solenoid or starter. 9. Contact an authorized service center/department.
Engine clicks but will not start	<ol style="list-style-type: none"> 1. Weak or dead battery. 2. Corroded battery terminals. 3. Loose or damaged wiring. 4. Faulty solenoid or starter. 	<ol style="list-style-type: none"> 1. Recharge or replace battery. 2. Clean battery terminals. 3. Check all wiring. 4. Check/replace solenoid or starter.
Loss of power	<ol style="list-style-type: none"> 1. Cutting too much grass/too fast. 2. Throttle in "CHOKE" position. 3. Build-up of grass, leaves, trash under mower. 4. Dirty air filter. 5. Low oil level/dirty oil. 6. Faulty spark plug. 7. Dirty fuel filter. 8. Stale or dirty fuel. 9. Water in fuel. 10. Spark plug wire loose. 11. Dirty engine air screen/fins. 12. Dirty/clogged muffler. 13. Loose or damaged wiring. 14. Carburetor out of adjustment. 15. Engine valves out of adjustment. 	<ol style="list-style-type: none"> 1. Raise cutting height/reduce speed. 2. Adjust throttle control. 3. Clean underside of mower housing. 4. Clean/replace air filter. 5. Check oil level/change oil. 6. Clean and regap or change spark plug. 7. Replace fuel filter. 8. Empty fuel tank and refill tank with fresh, clean gas. 9. Empty fuel tank and carburetor, refill tank with fresh gasoline and replace fuel filter. 10. Connect and tighten spark plug wire. 11. Clean engine air screen/fins. 12. Clean/replace muffler. 13. Check all wiring. 14. See "To Adjust Carburetor" in Service Adjustments section. 15. Contact an authorized service center/department.
Excessive vibration	<ol style="list-style-type: none"> 1. Worn, bent or loose blade. 2. Bent blade mandrel. 3. Loose/damaged part(s). 	<ol style="list-style-type: none"> 1. Replace blade. Tighten blade bolt. 2. Replace blade mandrel. 3. Tighten loose part(s). Replace damaged parts.

TROUBLESHOOTING POINTS

PROBLEM	CAUSE	CORRECTION
Engine continues to run when operator leaves seat with attachment clutch engaged	<ol style="list-style-type: none"> 1. Faulty operator-safety presence control system. 	<ol style="list-style-type: none"> 1. Check wiring, switches and connections. If not corrected, contact an authorized service center/department.
Poor cut - uneven	<ol style="list-style-type: none"> 1. Worn, bent or loose blade. 2. Mower deck not level. 3. Buildup of grass, leaves, trash under mower. 4. Bent blade mandrel. 5. Clogged mower deck vent holes from buildup of grass, leaves, and trash around mandrels. 	<ol style="list-style-type: none"> 1. Replace blade. Tighten blade bolt. 2. Level mower deck. 3. Clean underside of mower housing. 4. Replace blade mandrel. 5. Clean around mandrels to open vent holes.
Mower blades will not rotate	<ol style="list-style-type: none"> 1. Obstruction in clutch mechanism. 2. Worn/damaged mower drive belt. 3. Frozen idler pulley. 4. Frozen blade mandrel. 	<ol style="list-style-type: none"> 1. Remove obstruction. 2. Replace mower drive belt. 3. Replace idler pulley. 4. Replace blade mandrel.
Poor grass discharge	<ol style="list-style-type: none"> 1. Engine speed too slow. 2. Travel speed too fast. 3. Wet grass. 4. Mower deck not level. 5. Low/uneven tire air pressure. 6. Worn, bent or loose blade. 7. Buildup of grass, leaves, trash under mower. 8. Mower drive belt worn. 9. Blades improperly installed. 10. Improper blades used. 11. Clogged mower deck vent holes from buildup of grass, leaves, trash around mandrels. 	<ol style="list-style-type: none"> 1. Place throttle control in "FAST" position. 2. Shift to slower speed. 3. Allow grass to dry before mowing. 4. Level mower deck. 5. Check tires for proper air pressure. 6. Replace blade. Tighten blade bolt. 7. Clean underside of mower housing. 8. Replace mower drive belt. 9. Reinstall blades sharp edge down. 10. Replace with blades listed in parts manual. 11. Clean around mandrels to open vent holes.
Headlight(s) not working (if so equipped)	<ol style="list-style-type: none"> 1. Switch is "OFF". 2. Bulb(s) or lamp(s) burned out. 3. Faulty light switch. 4. Loose or damaged wiring. 5. Blown fuse. 	<ol style="list-style-type: none"> 1. Turn switch "ON". 2. Replace bulb(s) or lamp(s). 3. Check/replace light switch. 4. Check wiring and connections. 5. Replace fuse.
Battery will not charge	<ol style="list-style-type: none"> 1. Bad battery cell(s). 2. Poor cable connections. 3. Faulty regulator (if so equipped). 4. Faulty alternator. 	<ol style="list-style-type: none"> 1. Replace battery. 2. Check/clean all connections. 3. Replace regulator. 4. Replace alternator.
Loss of drive	<ol style="list-style-type: none"> 1. Freewheel control in "disengaged" position. 2. Debris on steering plate (if equipped). 3. Motion drive belt worn, damaged, or broken. 4. Air trapped in transmission during shipment or servicing. 5. Axle key missing. 	<ol style="list-style-type: none"> 1. Place freewheel control in "engaged" position. 2. See "CLEANING" in the maintenance section. 3. Replace motion drive belt. 4. Purge transmission. 5. Install axle key at rear wheel. See "TO REMOVE WHEEL" in the Service and Adjustments section.
Engine "back-fires" when turning engine "OFF"	<ol style="list-style-type: none"> 1. Engine throttle control not set between half and full speed (fast) position before stopping engine. 	<ol style="list-style-type: none"> 1. Move throttle control between half and full speed (fast) position before stopping engine.
Engine dies when tractor is shifted into reverse	<ol style="list-style-type: none"> 1. Reverse operation system (ROS) is not "ON" while mower or other attachment is engaged. 	<ol style="list-style-type: none"> 1. Turn ignition key to ROS "ON" position. See Operation section.

SERVICE NOTES

TRACTOR - - MODEL NUMBER 944.600090

SCHEMATIC

SCH12

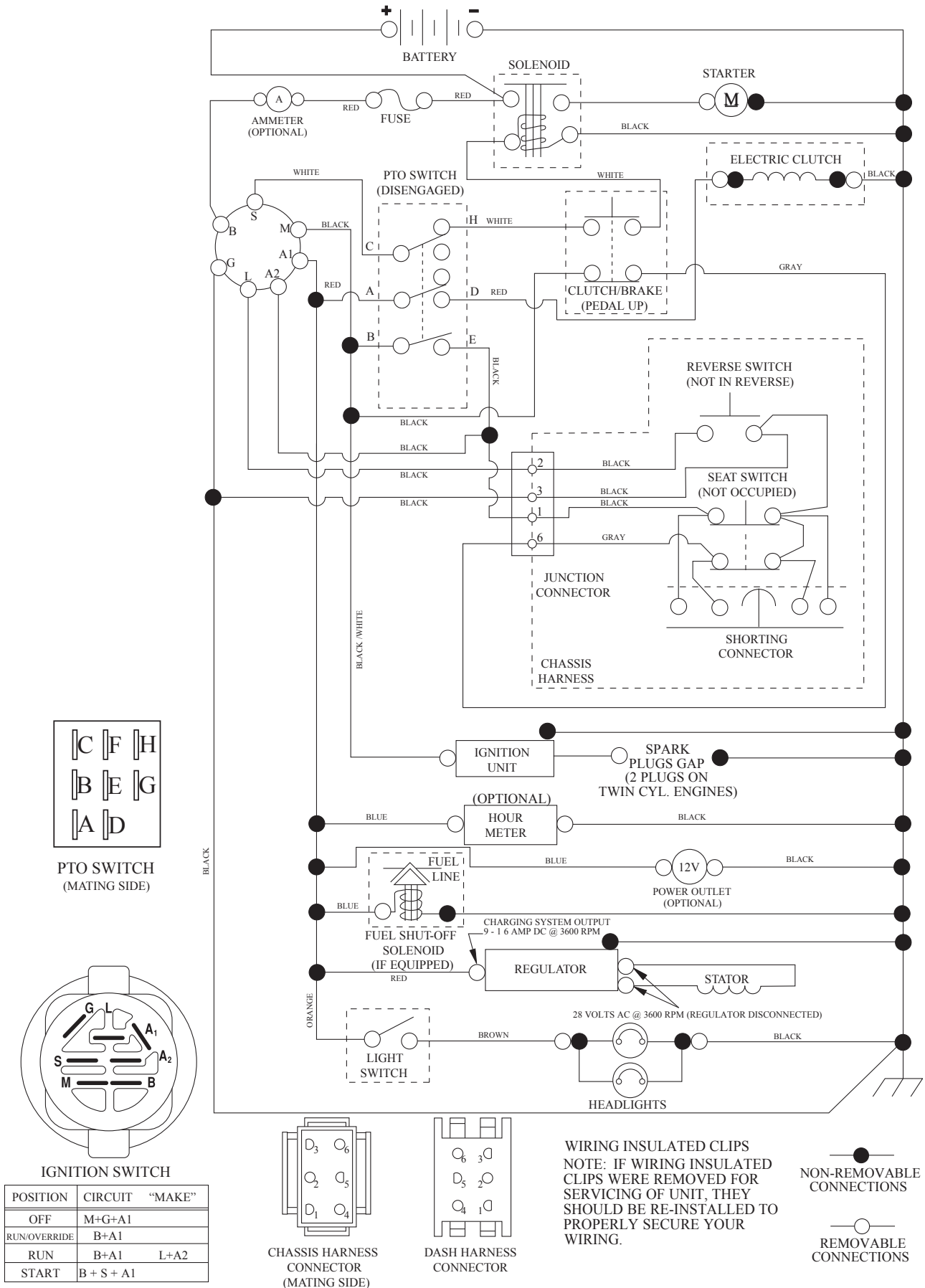

TRACTOR - - MODEL NUMBER 944.600090

ELECTRICAL

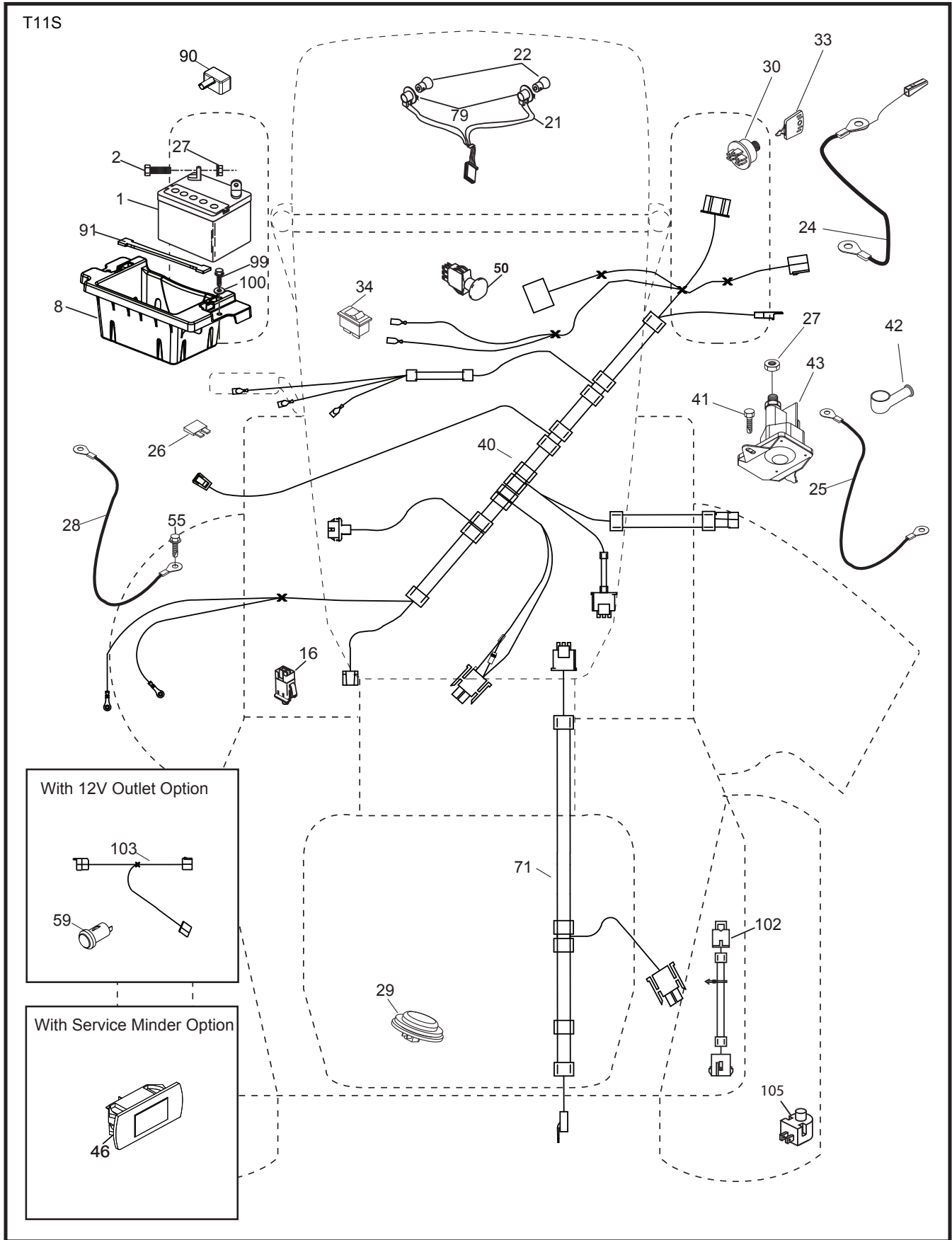

TRACTOR - - MODEL NUMBER 944.600090

ELECTRICAL

KEY NO.	PART NO.	DESCRIPTION
1	163465	Battery
2	74760412	Bolt Hex Head 1/4-20 x 3/4
8	186491	Box Battery
16	176138	Switch Interlock Push-In
21	400252	Harness Socket Light w/4152J
22	4152J	Bulb Light
24	400253	Cable Battery
25	412895	Cable Start Red
26	175158	Fuse
27	73510400	Nut Keps Hex 1/4-20 unc
28	145491	Cable, Ground
29	401545	Switch, Seat
30	193350	Switch, Ignition
33	411934	Key/Chain
34	110712X	Switch Light / Reset
40	401104	Harness Ign. Dash
41	17720408	Screw Thd Cut 1/4-20 x 1/2
42	131563	Cover, Terminal
43	192507	Solenoid
46	401763	Gauge Hourmeter
50	174652	Switch, PTO
55	17060512	Screw 5/16-18 x 3/4
59	400303	Outlet 12-Volt
71	194276	Harness Ignition
79	175242	Bulbholder Asm. Incan Descent
90	400724	Cover Terminal Battery
91	190270	Strap Battery Mount Front
99	17670412	Screw Hexwsh Thdrol 1/4-20 x 3/4
100	19091416	Washer 9/32 x 7/8 x 16 Ga.
103	407962	Harness Pigtail 12V Outlet
102	404454	Harness Pigtail
105	407568	Switch Reverse

NOTE: All component dimensions given in U.S. inches
1 inch = 25.4 mm

TRACTOR - - MODEL NUMBER 944.600090

CHASSIS

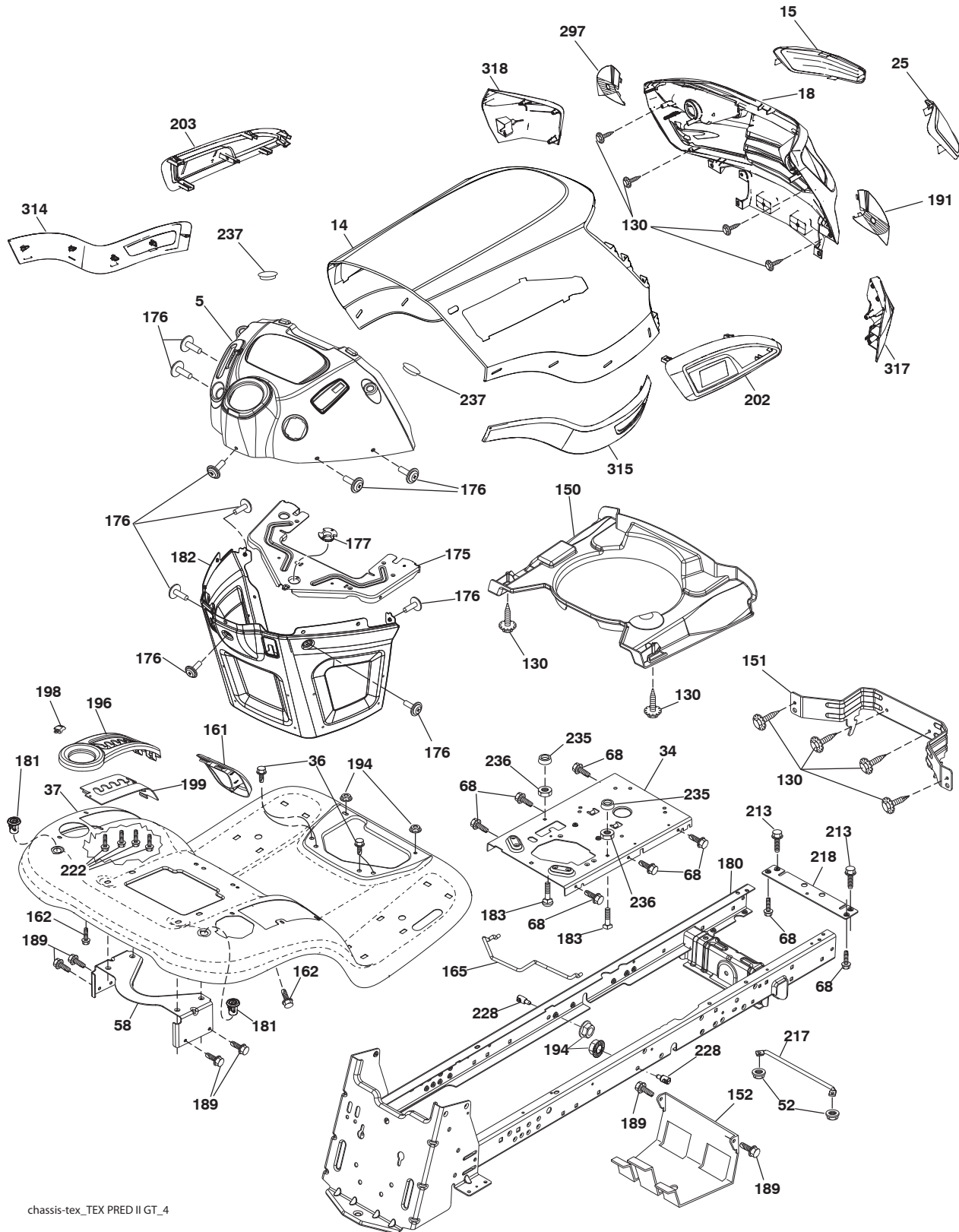

chassis-tex_TEX PRED II GT_4

TRACTOR - - MODEL NUMBER 944.600090

CHASSIS

KEY NO.	PART NO.	DESCRIPTION
5	421811X428	Dash
14	421154X428	Hood
15	421493X599	Lens LH
18	423158	Grille
25	421494X599	Lens RH
34	196125	Plate Engine
36	17060512	Screw 5/16-18 x 3/4
37	400009X428	Fender
52	73680500	Nut Crown Lock 5/16-18
58	194314	Bracket Fender
68	17490508	Screw Thdrol 5/16-18 x 1/2
130	416358	Screw #10 x 0.750 BOS Thread
150	199411	Duct Heat Hood
151	196332	Bracket Pivot
152	199535	Shield Browning/Debris
161	193097X428	Console Fuel Window
162	142432	Screw Hex Wsh Hi-Lo 1/4 x 1/2
165	196826	Bracket Support Tank
175	196304	Crossmember
176	400776	Screw #10-24 x 5/8 Rnd Qudrx
177	195227	Bushing Steering
180	195477	Chassis
181	193102X428	Bushing Mtg. Fender Crgo.
182	406859	Dash Lower
183	74520520	Bolt 5/16-18 x 1-1/4
189	17000512	Screw 5/16-18 x 3/4
191	425407	Insert Reflective RH
194	73900500	Nut Lock Hex Flange 5/16-18
196	196379X428	Console Asm. Deck Lift
198	197300X505	Indicator Deck Lift
199	196377	Plate Deck Lift
202	423175	Vent Side Hood RH
203	423174	Vent Side Hood LH
213	74760512	Bolt Hex HD 5/16-18 unc x 3/4
217	409167	Rod Pivot
218	196395	X-Piece Hood Stop
222	137729	Screw thd Roll 1/4-20 x 5/8
228	195161	Stud Fastener
235	406129	Spacer Fender
236	73930500	Nut Center Lock 5/16-18 unc
237	403704	Plug Mount
297	425406	Insert Reflective LH
314	423149	Trim SD LH
315	423150	Trim SD RH
317	421257X428	Cap Corner RH
318	421258X428	Cap Corner LH

NOTE: All component dimensions given in U.S. inches
1 inch = 25.4 mm

TRACTOR - - MODEL NUMBER 944.600090

DRIVE

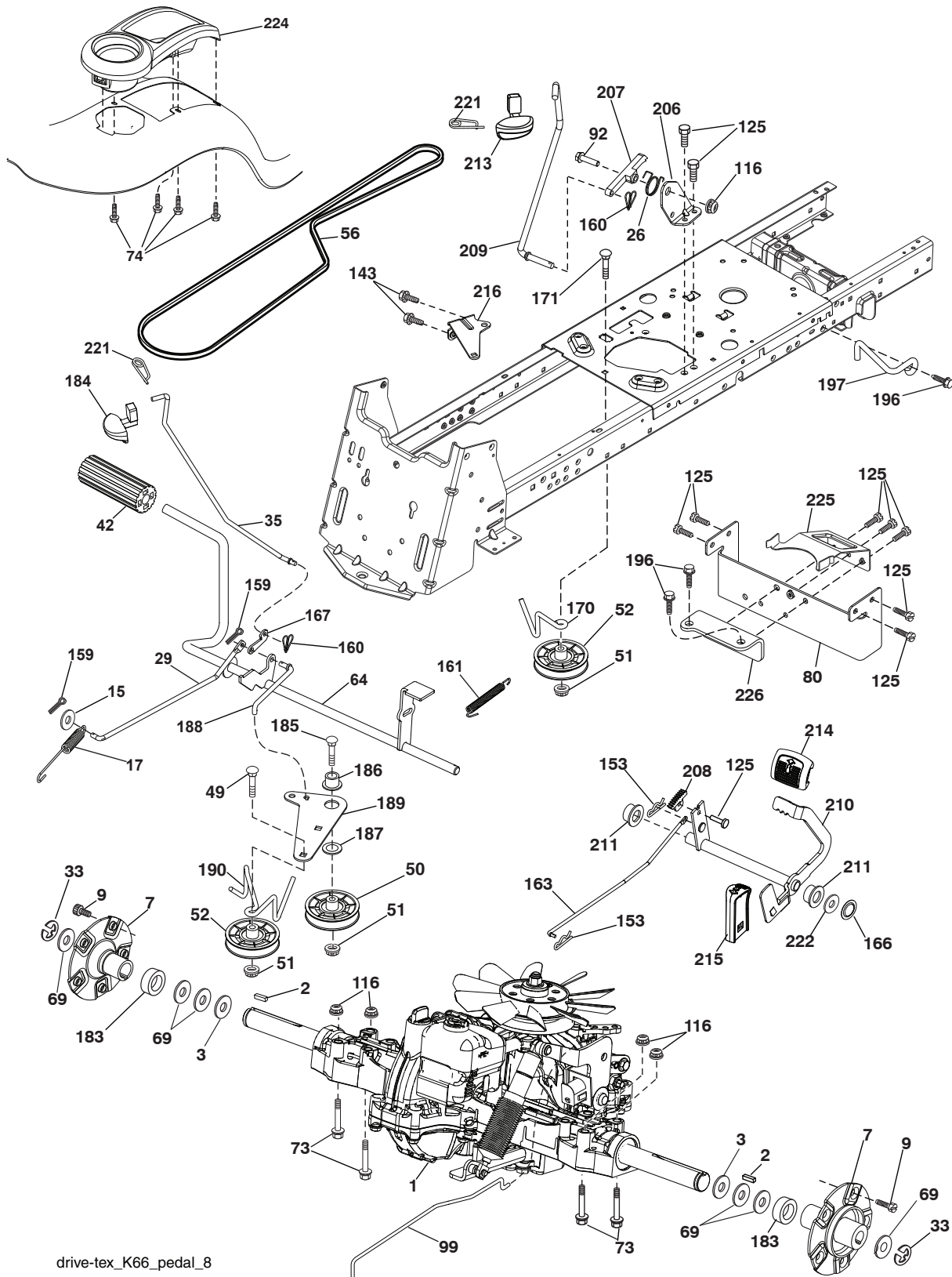

drive-tex_K66_pedal_8

TRACTOR - - MODEL NUMBER 944.600090

DRIVE

KEY NO.	PART NO.	DESCRIPTION	KEY NO.	PART NO.	DESCRIPTION
1	-----	Transaxle, HTufftorq K66Y (See Transaxle Breakdown)	171	72110616	Bolt
2	7070E	Key 1/4 x 2.5	183	197357	Spacer Axle
3	7563R	Washer Thrust Axle Hardened	184	196439X505	Handle Parking Brake
7	199837	Hub Asm. Wheel	185	72110622	Bolt Rdhd Sqnk 3/8-16 x 2-3/4
9	140080	Bolt Hub Wheel	186	194321	Spacer Retainer
15	19131316	Washer 13/32 x 13/16 x 16 Ga.	187	19133210	Washer
17	401072	Spring, Brake	188	194323	Link Clutch Ground Drive
26	199679	Spring Return Cruise	189	194317	Bellcrank Ground Drive
29	407245	Rod, Brake	190	194318	Keeper Bellcrank Ground Drive
33	12000053	Ring E	196	17000616	Screw 3/8-16 x 1
35	199591	Rod, Brake, Park	197	199769	Bracket Clutch Anti-Rotation
42	8883R	Cover, Foot Pedal	206	197867	Bracket Mount Latch Cruise
49	72110614	Bolt	207	197868	Latch Control Cruise
50	194327	Pulley Idler Flat	208	197869	Gear Sector Control Cruise
51	73900600	Lock Nut 3/8-16	209	199592	Rod Control Cruise
52	194326	Idler V-Groove 910" Offset	210	197860	Rocker Asm. Pedal Control
56	125907X	V-Belt, Drive	211	120183X	Bearing Nylon
64	197865	Shaft Asm. Pedal Brake Control	213	196441X428	Knob Control Cruise
69	123800X	Washer 1-1/32 x 1-5/8 x 16 Ga.	214	421263	Pedal Forward
73	74490544	Bolt Hex 5/16-18 Gr. 5	215	197301X428	Pedal Reverse
74	142432	Screw 1/4 x 1/2	216	196131	Bracket Pulley Idler
80	407182	Strap Torque	221	403187	Retainer Spring Clip Handle
92	74760520	Bolt 5/16-18 x 1/2	222	79212010	Washer 21/32 x 1-1/4 x 10 Ga.
99	415744	Rod Bypass	224	193099X428	Console Toolbox
116	73900500	Nut Lock Hex Flange 5/16-18	225	407311	Keeper Belt Trans.
125	17000512	Screw 5/16-18 x 3/4	226	407109	Bracket Mount Torque
143	17490508	Screw 5/16-18 x 1/2			
153	4497H	Retainer Spring			
159	76020412	Pin Cotter 1/8 x 3/4			
160	169484	Retainer Clip			
161	105709X	Spring, Return, Clutch			
163	407246	Rod Pedal Control			
166	429164	Nut Push .625			
167	405257	Latch Brake Parking			
170	194322	Keeper Belt Centerspan			

NOTE: All component dimensions given in U.S. inches
1 inch = 25.4 mm

TRACTOR - - MODEL NUMBER 944.600090

ENGINE

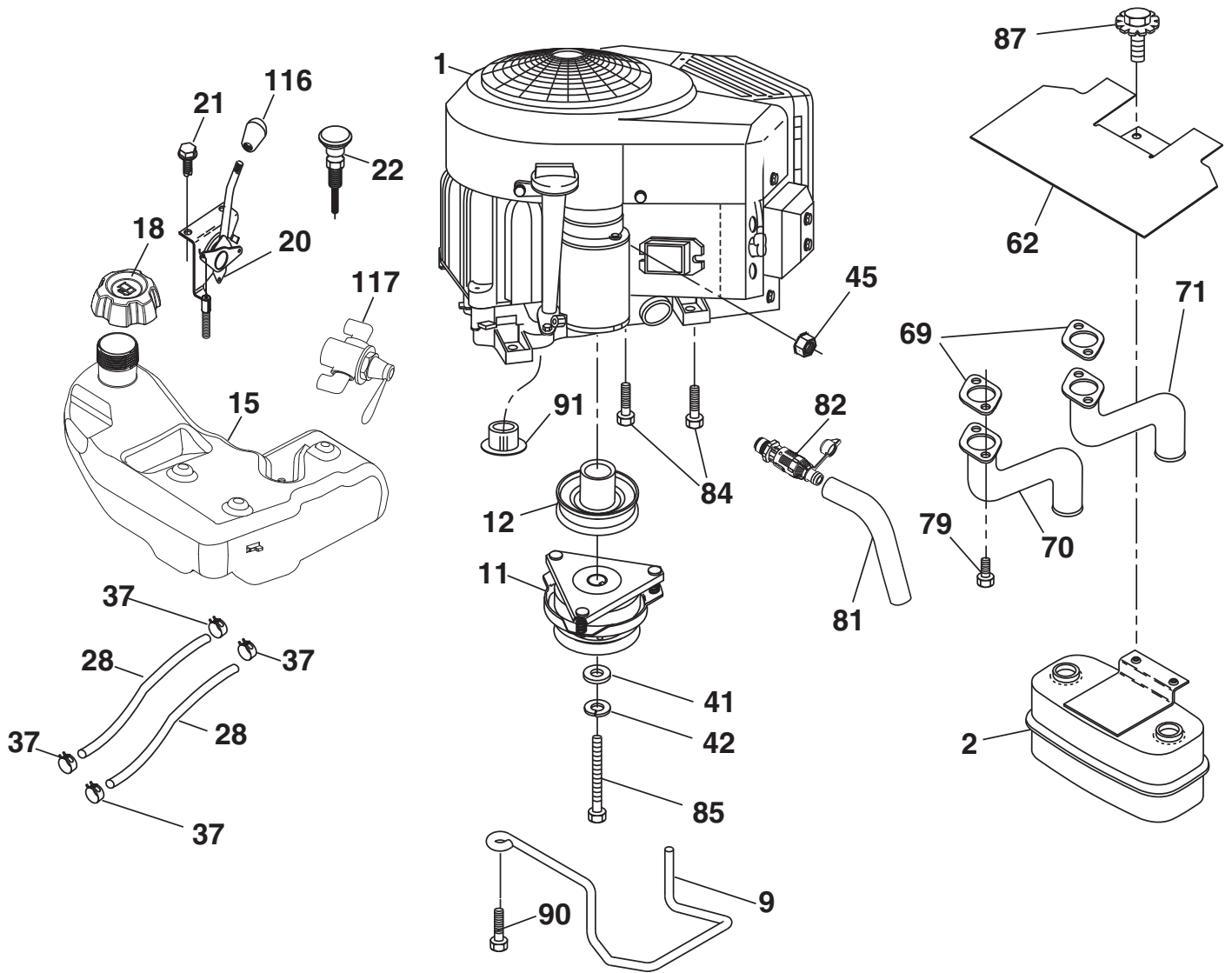

SPARK ARRESTER KIT

engine-tex_bs-2cyl_66

TRACTOR - - MODEL NUMBER 944.600090

ENGINE

KEY NO.	PART NO.	DESCRIPTION
1	-----	Engine B&S Model No. 445877-0760-B1 (See Engine Breakdown)
2	149723	Muffler
9	194320	Keeper Asm. Belt Engine
11	179335	Clutch Electric
12	194343	Pulley Engine
15	422804	Tank Fuel 4.0
18	430218	Cap Asm
20	426184	Control Throttle
21	416358	Screw #10 x 0.750 BOS Thread
22	187767X428	Control Choke
28	401135	Fuel Line
29	137180	Spark Arrester Kit
37	123487X	Clamp Hose
41	126197X	Washer 1-1/2 OD x 15/32 ID x .250
42	STD551143	Washer Lock 7/16
45	73510400	Nut Keps Hex 1/4-20 unc
62	434017	Shield Heat Muffler
69	165391	Gasket
70	159955	Tube Exhaust LH
71	160589	Tube Exhaust RH
79	183906	Screw 5/16-18 x 1
81	148456	Tube Drain Oil Easy
82	428287	Valve Drain Oil
84	17060620	Screw 3/8-16 x 1 1/4
85	179953	Bolt Hex 7/16-20 x 3.75 Gr. 5
87	198239	Bolt 5/16-18 unc x 1 w/Sems
90	17000616	Screw 3/8-16 x 1
91	187495	Bushing 1.375 OD
116	423109X659	Knob Oval
117	420828	Valve Fuel Reserve

NOTE: All component dimensions given in U.S. inches
1 inch = 25.4 mm

For engine service and replacement parts, call the toll free number for your engine manufacturer listed below:

Briggs & Stratton 1-800-233-3723

TRACTOR - - MODEL NUMBER 944.600090

STEERING ASSEMBLY

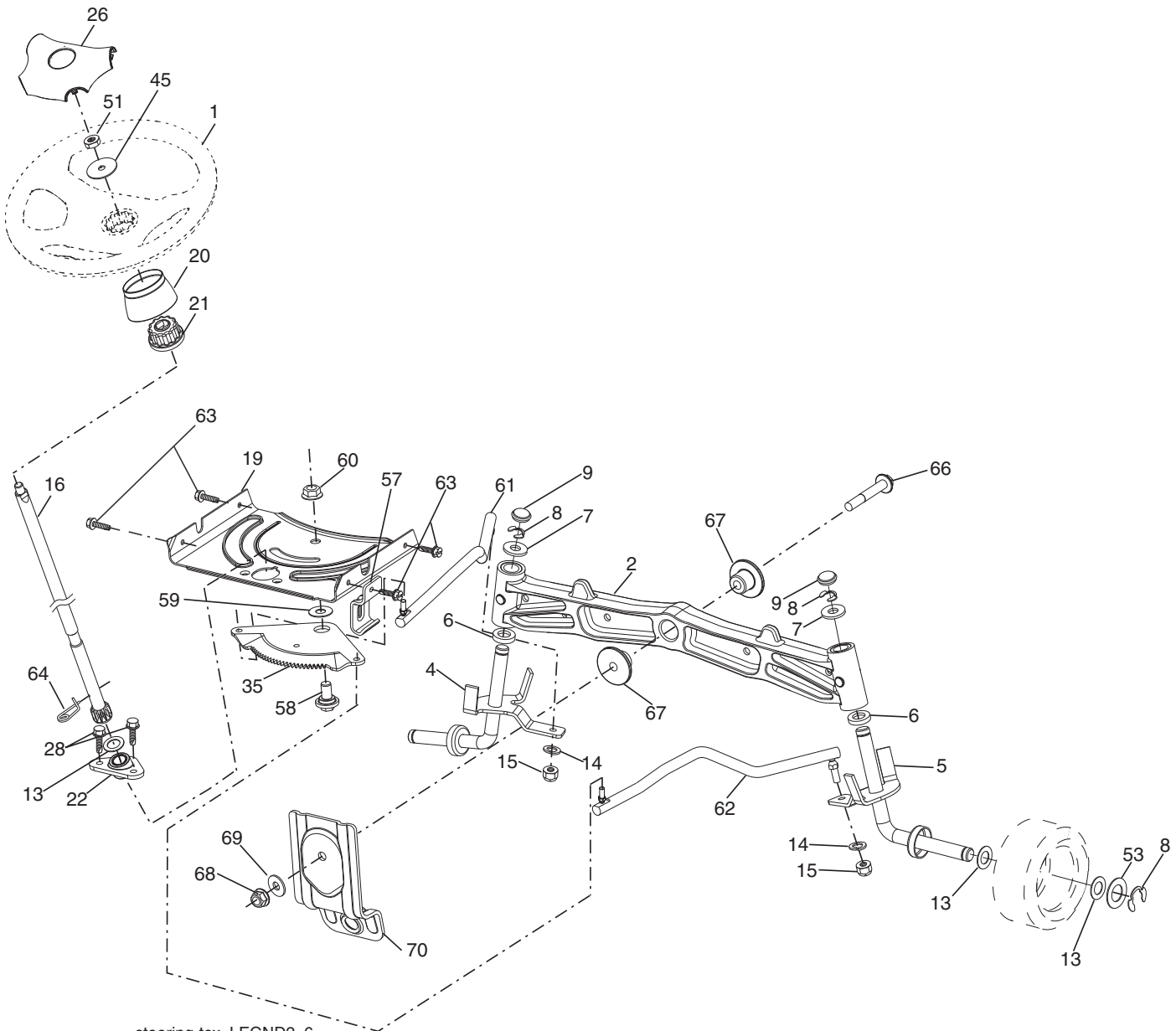

steering-tex_LEGND2_6

KEY NO.	PART NO.	DESCRIPTION
1	414851X659	Wheel, Steering
2	195968	Axle Asm., Front
4	403089	Spindle Asm., LH
5	403090	Spindle Asm., RH
6	6266H	Bearing, Race Thrust Harden
7	121748X	Washer 25/32 x 1-5/8 x 16 Ga.
8	12000029	Ring, Klip #T5304-75
9	184946X505	Cap, Spindle
13	121749X	Washer 25/32 x 1-1/4 x 16 Ga.
14	STD551137	Washer, Lock Hvy Hlcl Spr 3/8
15	73540600	Nut, Crown Lock 3/8-24 unf
16	408219	Shaft Steering
19	194729	Plate Steering
20	199676X428	Boot, Steering
21	186737	Adapter, Wheel Steering
22	420537	Support Strg. Lower
26	414852X659	Insert, Wheel Steering
28	17000612	Screw 3/8-16 x 3/4
35	194732	Gear, Sector Plate

KEY NO.	PART NO.	DESCRIPTION
45	19183812	Washer 9/16 x 2-3/8 x 12 Ga.
51	73940800	Nut Hex Jam Toplock 1/2-20 unf
53	188967	Washer Hardened .793x1.637x.060
57	197246	Bracket Upstop
58	194747	Bolt Shoulder Sector Pivot CFM
59	194748	Washer Thrust Sector Steering
60	73971000	Nut Flange Lock 5/8-11
61	194740	Draglink LH
62	194741	Draglink, RH
63	17000512	Screw 5/16-18 x 3/4
64	199849	Retainer Clip Spring Steering
66	71020748	Bolt Hex Fghd 7/16-14 x 3 Serr
67	194737	Bushing PM Front Axle
68	73900700	Nut Lock Flange 7/16-14 Gr. 5
69	199162	Washer 1.5 x .505 x .118
70	196197	Bracket Deck Susp. Front

NOTE: All component dimensions given in U.S. inches
1 inch = 25.4 mm

TRACTOR - - MODEL NUMBER 944.600090

SEAT ASSEMBLY

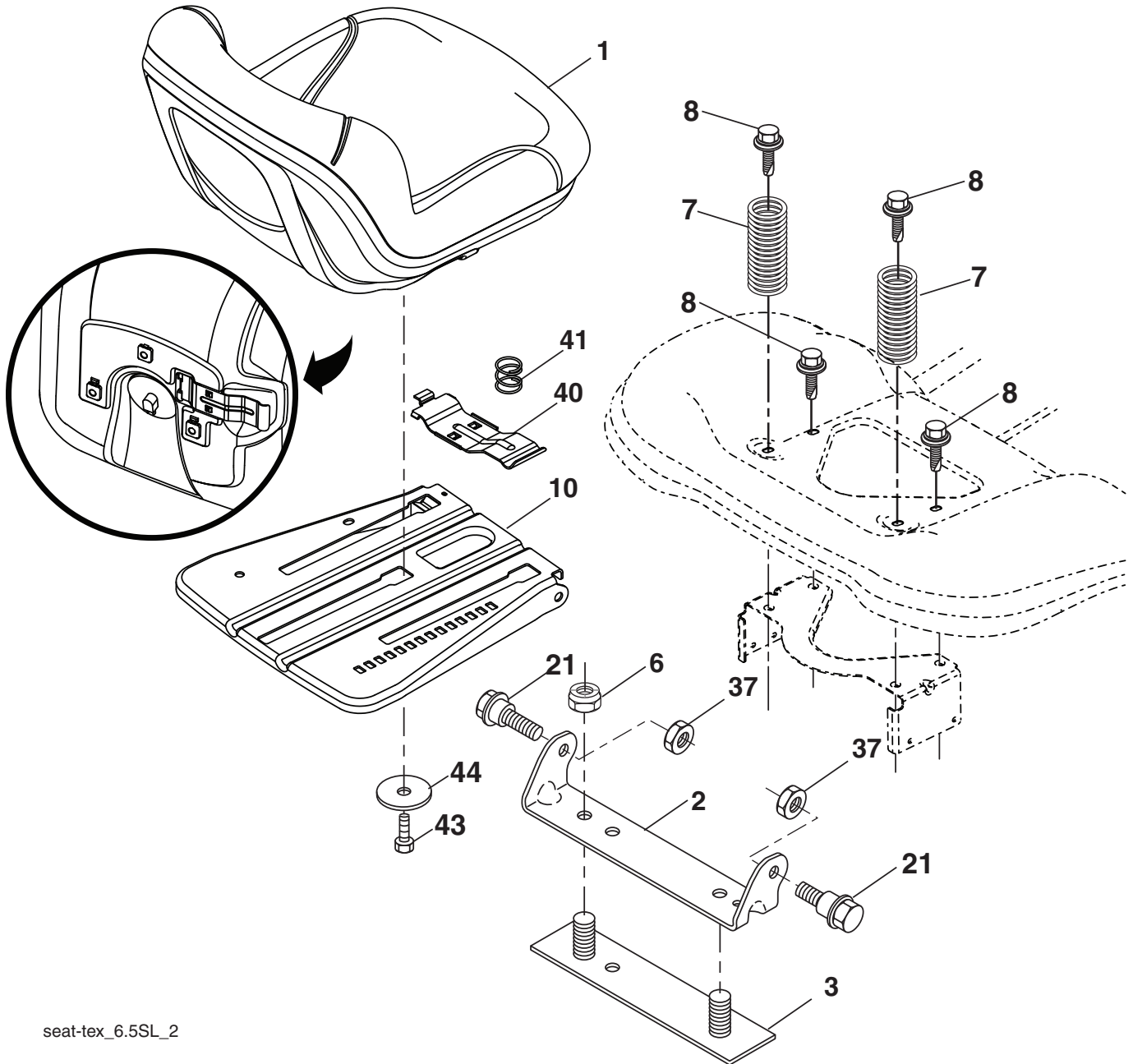

seat-tex_6.5SL_2

KEY NO.	PART NO.	DESCRIPTION
1	423810	Seat
2	180166	Bracket Pivot Fender
3	140675	Strap, Asm Fender
6	STD541437	Nut, Lock W/Ins. 3/8-16 unc
7	124181X	Spring, Seat Cprsn
8	171877	Bolt 5/16-18 unc x 3/4 w/Sems
10	196977	Pan, Seat
21	171852	Bolt, Shoulder 5/16-18

KEY NO.	PART NO.	DESCRIPTION
37	STD541431	Nut, Lock 5/16-18 unc
40	197661	Handle Slide Seat
41	198200	Spring Latch Seat
43	74760612	Bolt Fin Hex 3/8-16 unc x 3/4
44	19133812	Washer 13/32 x 2-3/8 x 12 Ga.

NOTE: All component dimensions given in U.S. inches
1 inch = 25.4 mm

TRACTOR - - MODEL NUMBER 944.600090

MOWER DECK

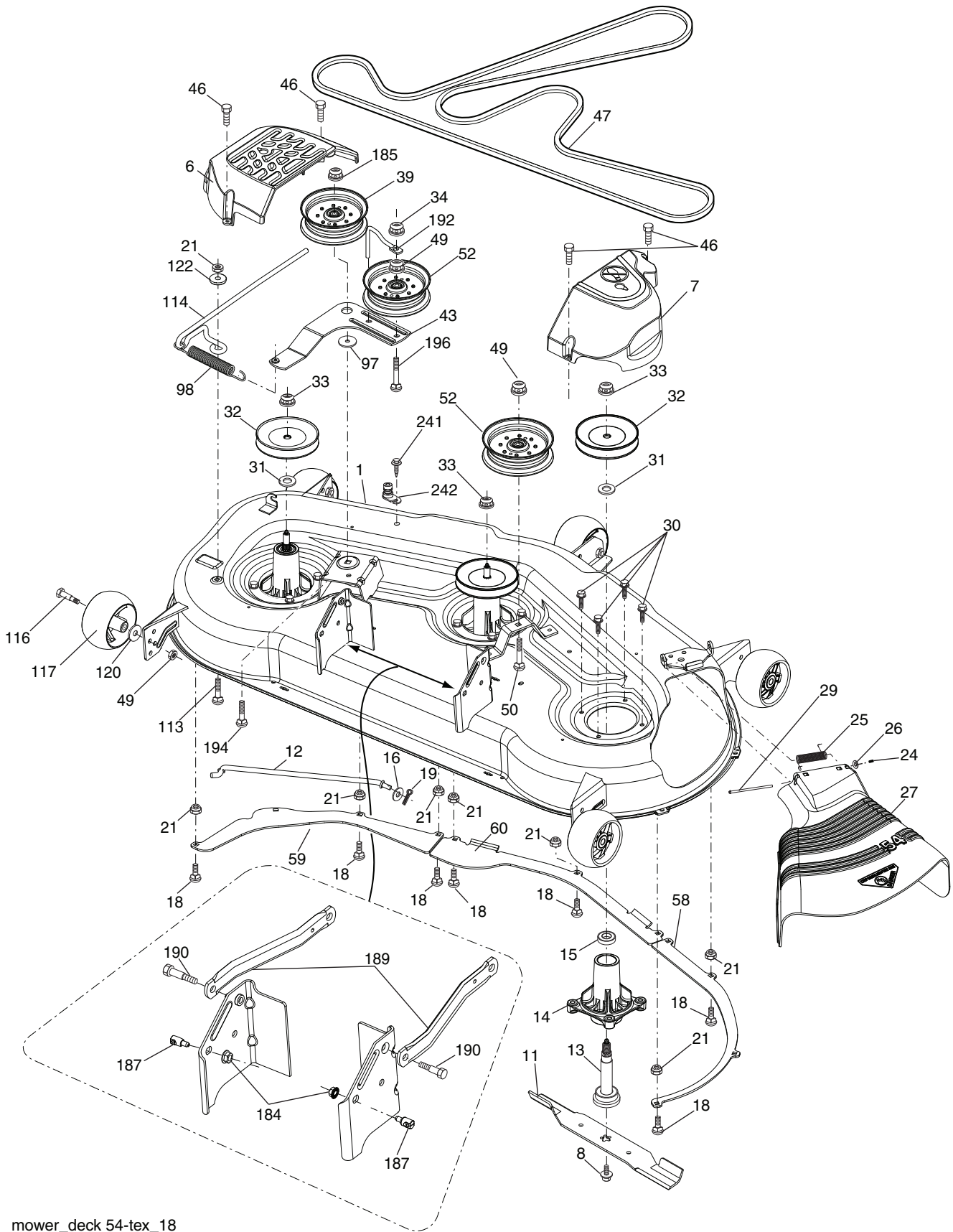

mower_deck 54-tex_18

TRACTOR - - MODEL NUMBER 944.600090

MOWER DECK

KEY NO.	PART NO.	DESCRIPTION	KEY NO.	PART NO.	DESCRIPTION
1	195632X613	Deck Weldment Mower	58	187342	Baffle Right
6	196066	Cover Mandrel LH	59	187344	Baffle Left
7	197181	Cover Mandrel RH	60	187607	Baffle Center
8	193003	Bolt/Washer Asm. 7/16-20 unf	97	178515	Washer Hardened
11	187256	Blade Bagging	98	196105	Spring Drive
--	187255	Blade Mulching	113	72110508	Bolt Rdhd Sqnk 5/16-18 x 3/4
12	400337	Rod Anti-Sway	114	187556	Rod Tension Relief
13	187291	Shaft Asm. w/Lower Bearing	116	193406	Bolt, Shoulder
14	187281	Housing, Mandrel	117	174873	Gauge Wheel
15	110485X	Bearing, Ball, Mandrel	120	19132012	Washer 13/32 x 1-1/4 x 12Ga.
16	19131312	Washer 13/32 x 13/16 x 12 Ga.	122	187557	Bushing Tension Relief
18	72140505	Bolt Rdhd Sqnk 5/16-18 x	184	73900500	Nut Lock Hex Flange 5/16-18
19	194208	Pin Cotter 5/16 Bow Tie Lock	185	73900700	Nut Lock Flange 7/16-14 Gr. 5
21	STD541431	Nut, Crownlock 5/16-18 unc	187	195161	Stud Fastener w/"D" Anti-Rotation
24	105304X	Cap Sleeve	189	195185	Arm Susp. Mower Rear
25	178102	Spring, Torsion	190	196539	Bolt Shoulder
26	110452X	Nut, Push	192	198468	Keeper Belt Idler
27	187257X428	Deflector Shield	194	72140716	Bolt Carr Sqnk 3/8-16 x 2-1/4
29	131491	Rod, Hinge	196	72140620	Bolt Rdhd Sqnk 3/8-16 x 2-1/2 Gr. 5
30	173984	Screw, Thdroll Washer Head	241	152927	Screw TT #10-32.5. 3/8 Flange
31	187690	Spacer, Mandrel	242	415598	Port Washout
32	153535	Pulley, Mandrel	--	416405	Coupling Quick Connect
33	400234	Nut, Flg. Top Lock	--	187292	Mandrel Assembly (Includes housing, shaft assembly, and bearing only - pulley/nut/washer and blade bolt/washers not included)
34	STD541437	Nut Crownlock 3/8-16 unc			Replacement Mower, Complete
39	197380	Pulley, Idler 4.50 RAW			
43	196065	Arm, Idler			
46	137729	Screw, Thdroll. 1/4-20 x 5/8	--	403349	
47	196103	V-Belt, Mower			
49	73900600	Nut, Lock Flg. 3/8-16 unc			
50	STD533720	Bolt RDHD SQNK 3/8-16 unc x 2			
52	197379	Pulley Idler 4.50 Hub Special			

NOTE: All component dimensions given in U.S. inches
1 inch = 25.4 mm

TRACTOR - - MODEL NUMBER 944.600090

MOWER LIFT

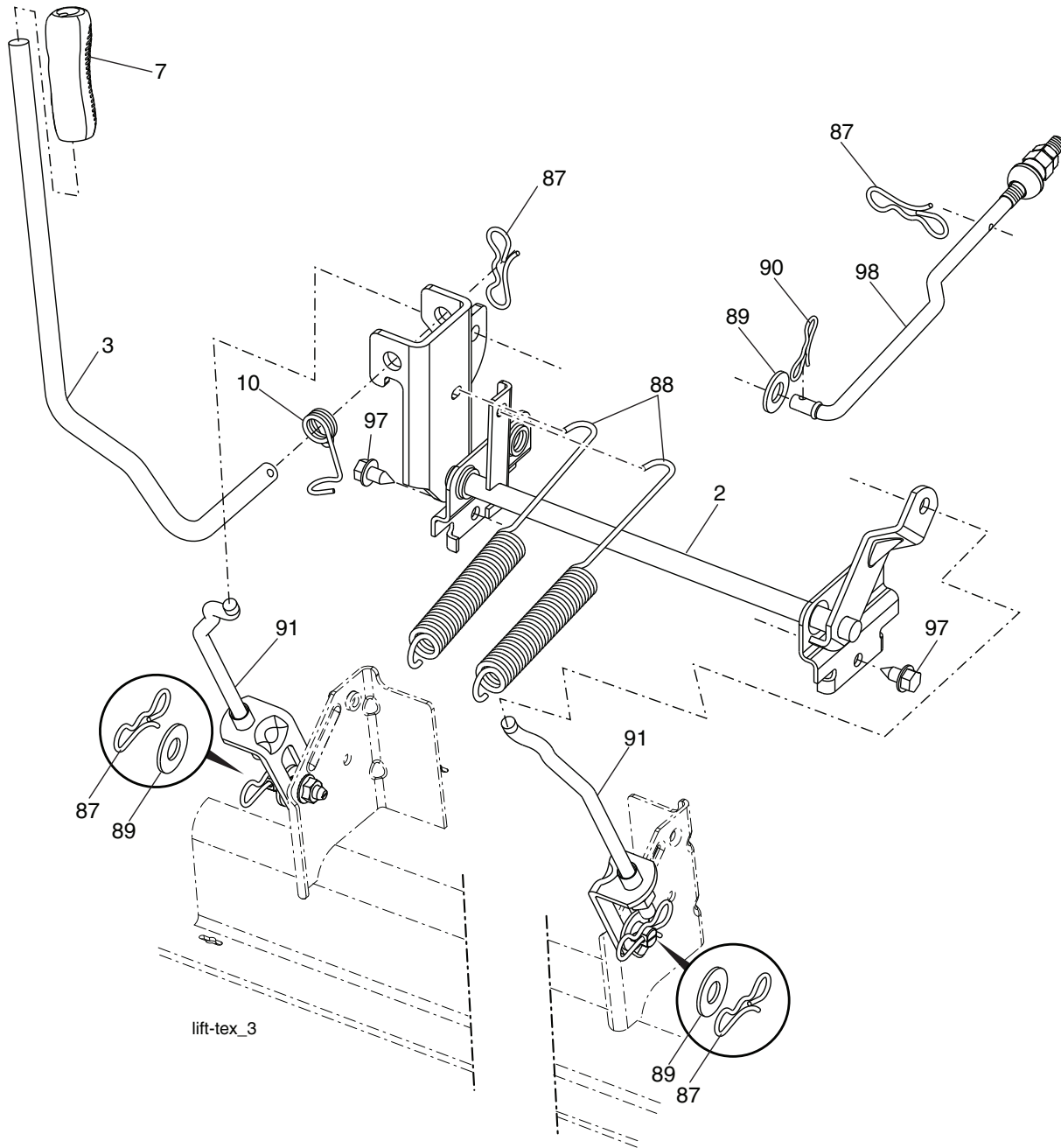

KEY NO.	PART NO.	DESCRIPTION
2	422027	Shaft Asm., Lift
3	195230	Lever Asm., Lift RH
7	196492X428	Grip, Lever
10	196314	Spring Torsion
87	194209	Pin Cotter 7/16 Bow Tie Lock
88	195304	Spring Lift Assist
89	19191912	Washer Clear Zinc

KEY NO.	PART NO.	DESCRIPTION
90	194208	Pin Cotter 5/16 Bow Tie Lock
91	403407	Link Lift Susp Mower Rear
97	17000612	Screw Hexwsh Thdrl. 3/8-16 x 3/4
98	195264	Link Lift Susp. Front Mower

NOTE: All component dimensions given in U.S. inches
1 inch = 25.4 mm

TRACTOR - - MODEL NUMBER 944.600090

DECALS

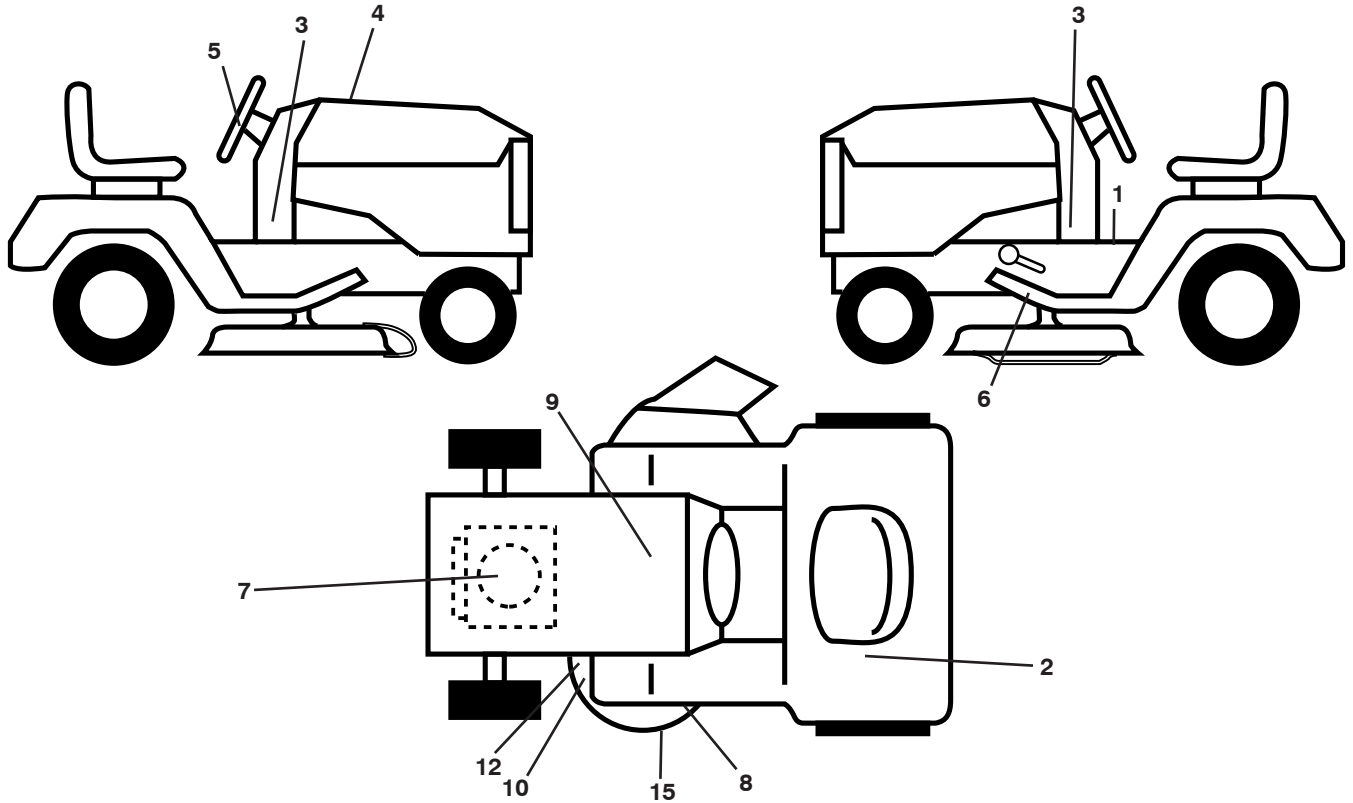

KEY NO.	PART NO.	DESCRIPTION	KEY NO.	PART NO.	DESCRIPTION
1	411658	Decal, Fender Warning	10	178455	Decal, Mower Caution
2	426209	Decal, Warning Reserve Fuel	12	170563	Decal, Mower Warning Keep Hand Away
3	426191	Decal, Lower Dash	15	426593	Decal, Deck PRC SN Plus
4	434769	Decal, Replacement	--	166960	Decal, Bypass Fender
5	422885	Decal, Strg Whl	--	193279X428	Pad, Footrest, RH
6	421534	Decal, V-Belt Sch	--	193101X428	Pad, Footrest, LH
7	411001	Decal, Engine	--	434838	Manual, Owner's (English)
8	198785	Decal, Mower Sch.	--	434839	Manual, Owner's (French)
9	149517	Decal, Battery Dnge/Poi			

WHEELS AND TIRES

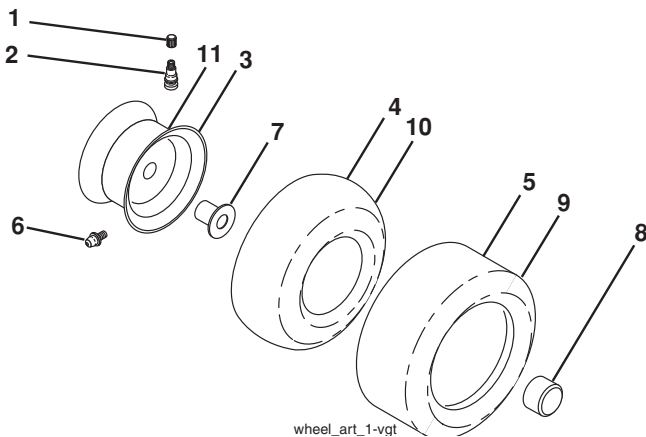

KEY NO.	PART NO.	DESCRIPTION
1	59192	Cap, Valve, Tire
2	65139	Stem, Valve
3	106228X613	Rim Assembly, Front
4	8134H	Tube, Front (Service Item Only)
5	106230X	Tire, Front
6	278H	Fitting, Grease (Front Wheel Only)
7	9040H	Bearing, Flange (Front Wheel Only)
8	104757X613	Cap, Axle
9	105588X	Tire, Rear
10	7154J	Tube, Rear (Service Item Only)
11	106277X613	Rim Assembly, Rear
--	144334	Sealant, Tire (10 oz. Tube)

NOTE: All component dimensions given in U.S. inches
1 inch = 25.4 mm

TRACTOR - - MODEL NUMBER 944.600090

TUFFTORQ TRANSAXLE - - MODEL NUMBER K66Y

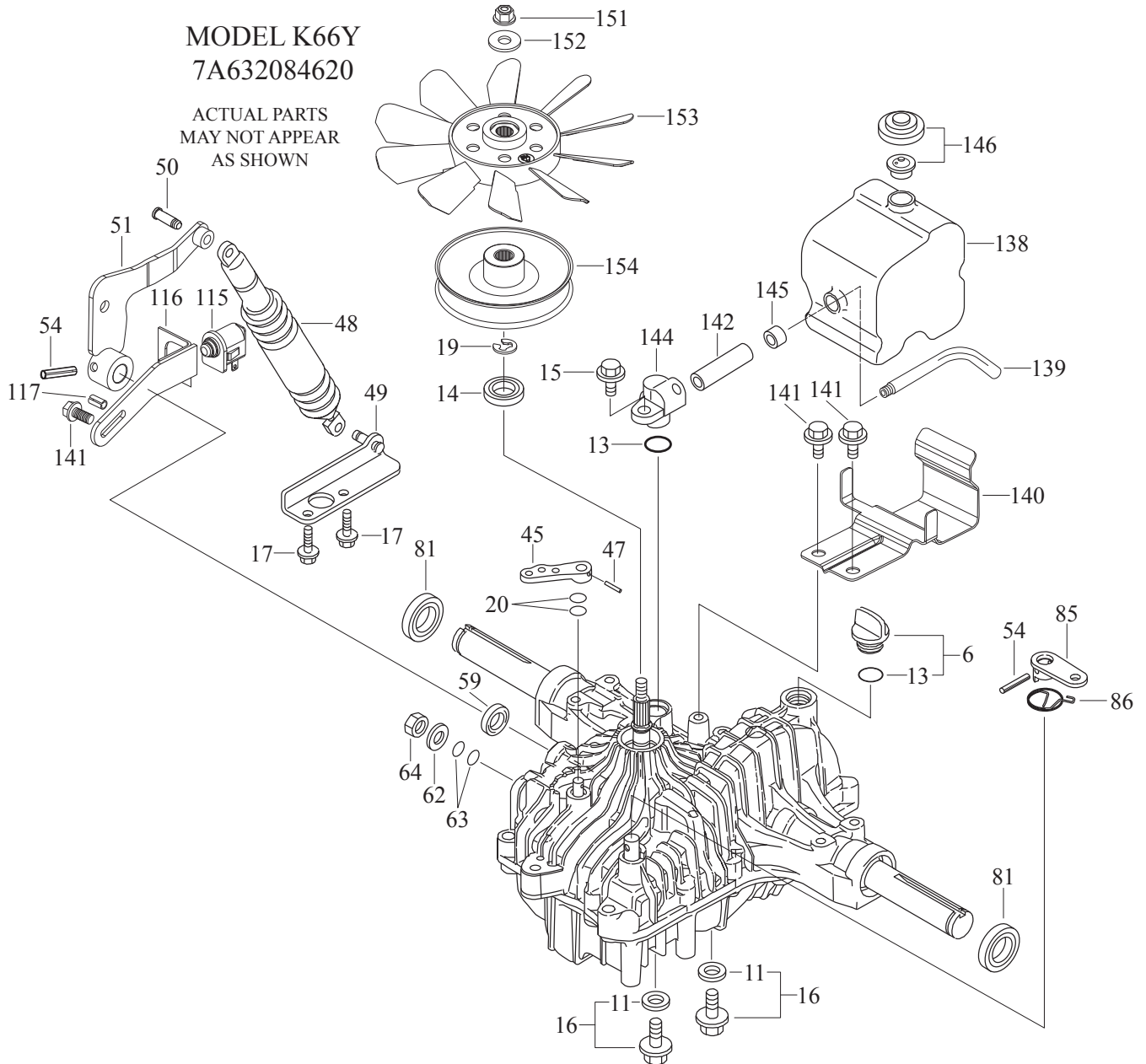

TRACTOR - - MODEL NUMBER 944.600090

TUFFTORQ TRANSAXLE - - MODEL NUMBER K66Y

KEY NO.	PART NO.	DESCRIPTION
6	414182	OIL CAP M20B PLASTIC
11	414183	SEAL WASHER 10
13	414184	O-RING P18
14	414185	SEAL TC 153507
15	414186	BOLT 8 * 20
16	414187	BOLT 10 * 12
17	414188	TAPPING SCREW 8 * 30
19	414189	E-RING 15
20	414190	O-RING 1A P10A
45	414191	BYPASS LEVER
47	414192	PIN 3.0A * 20
48	414193	SHOCK ABSORBER K65
49	414194	STAY
50	414195	PIN
51	414196	CONTROL LEVER
54	414197	ROLL PIN 6 * 40
59	414198	SEAL TC 162606
62	414199	WASHER 12
63	414200	O-RING 1A P14
64	414201	NUT 12
81	414202	SEAL (S25.4 * 42 * 8)
85	414203	BRAKE LEVER
86	414204	BRAKE RETURN SPRING
115	414205	SWITCH 6440-11 DELTA
116	414206	SWITCH PLATE
117	414207	ROLL PIN 8 * 16
138	414208	RESERVOIR TANK
139	414209	PIPE 8
140	414210	TANK BRACKET
141	414211	TAPPING SCREW 8 * 20
142	414212	TANK SPACER
144	414213	FITTING
145	414214	SEAL
146	414215	VENT VALVE 15
151	414216	LOCK NUT 10
152	414217	WASHER 11 * 32 * 3.2
153	414218	FAN
154	414414	PULLEY L

NOTE: All component dimensions given in U.S. inches
1 inch = 25.4 mm

TRACTOR - - MODEL NUMBER 944.600090

B&S ENGINE - MODEL NUMBER 445877, TYPE NUMBER 0760-B1

48 SHORT BLOCK

1058 OPERATOR'S MANUAL

1329 REPLACEMENT ENGINE

1330 REPAIR MANUAL

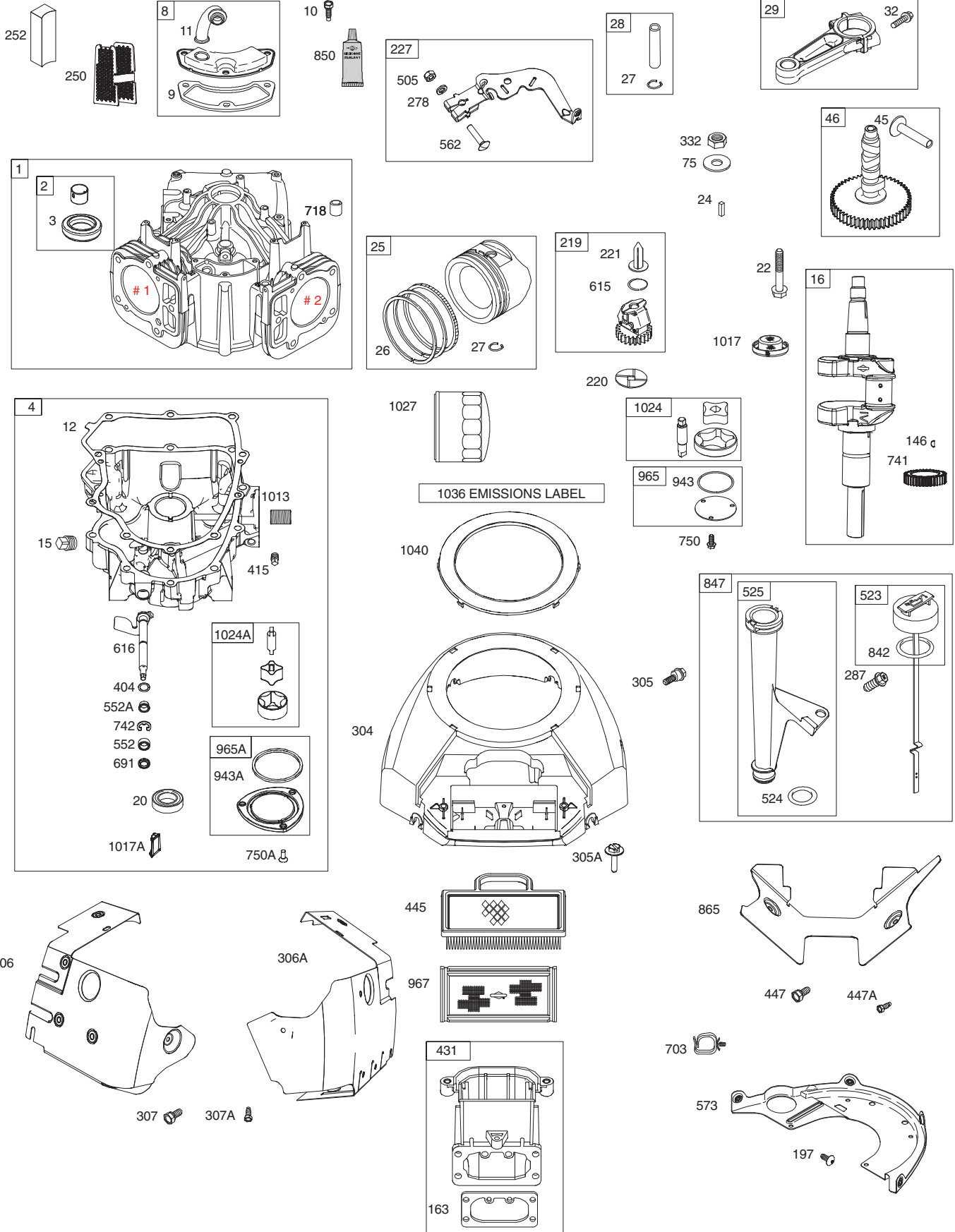

TRACTOR - - MODEL NUMBER 944.600090

B&S ENGINE - MODEL NUMBER 445877, TYPE NUMBER 0760-B1

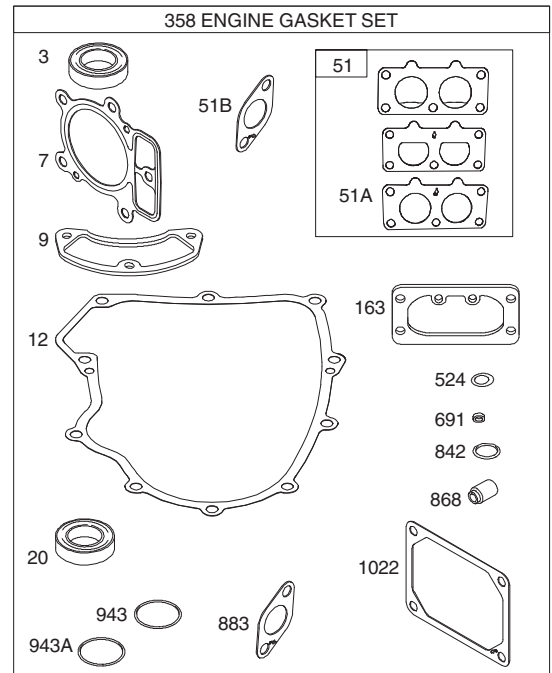
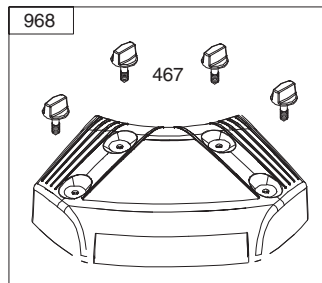
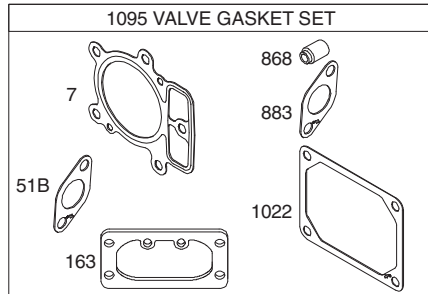
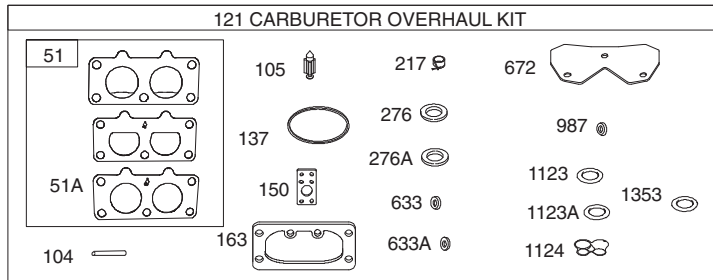
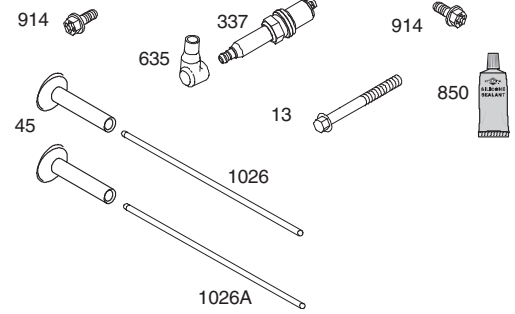
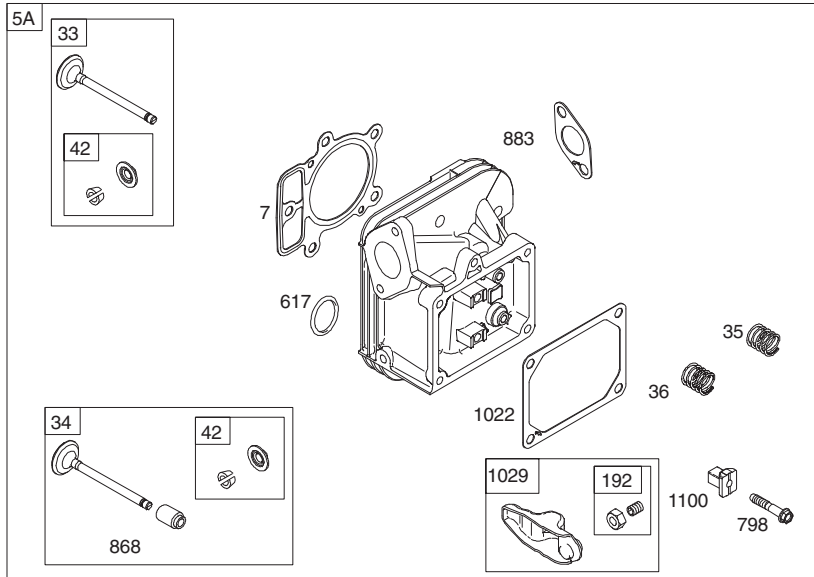
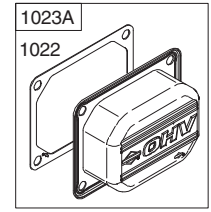
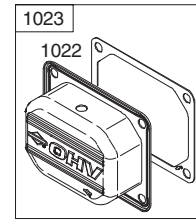
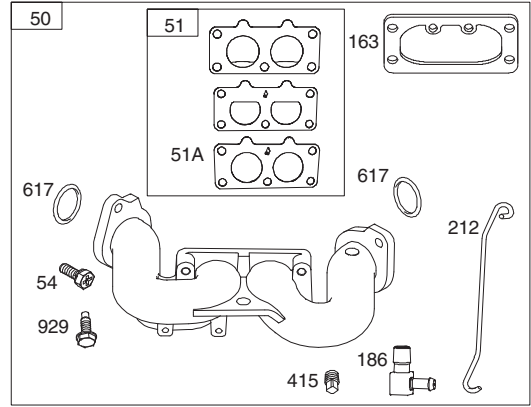
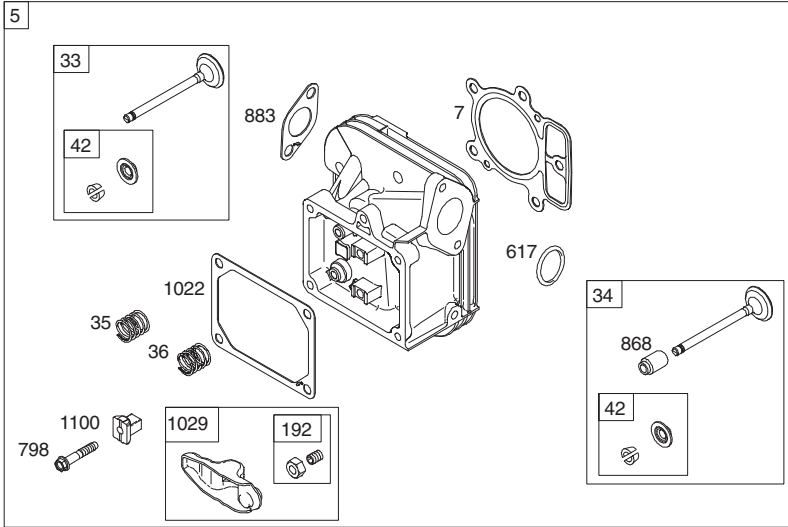

TRACTOR - - MODEL NUMBER 944.600090

B&S ENGINE - MODEL NUMBER 445877, TYPE NUMBER 0760-B1

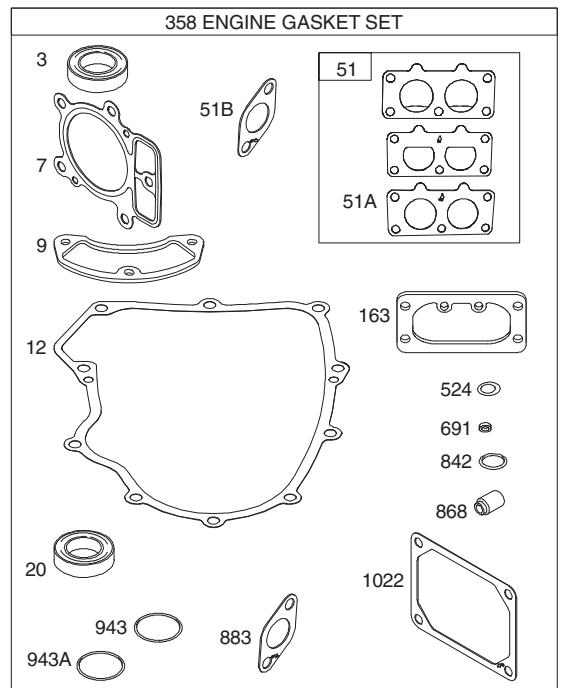
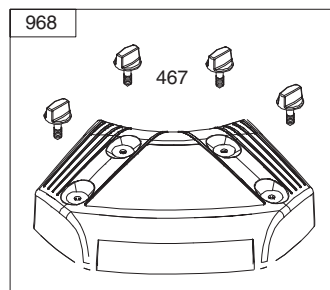
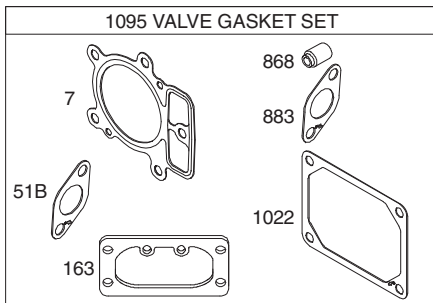
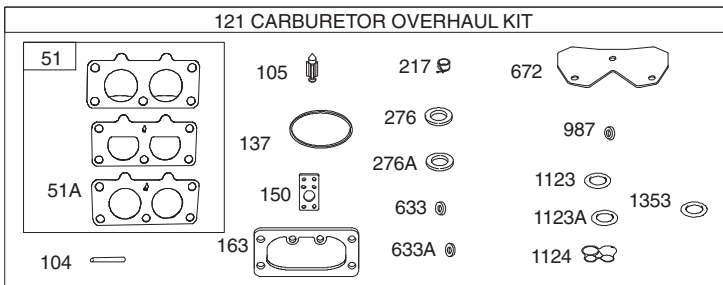
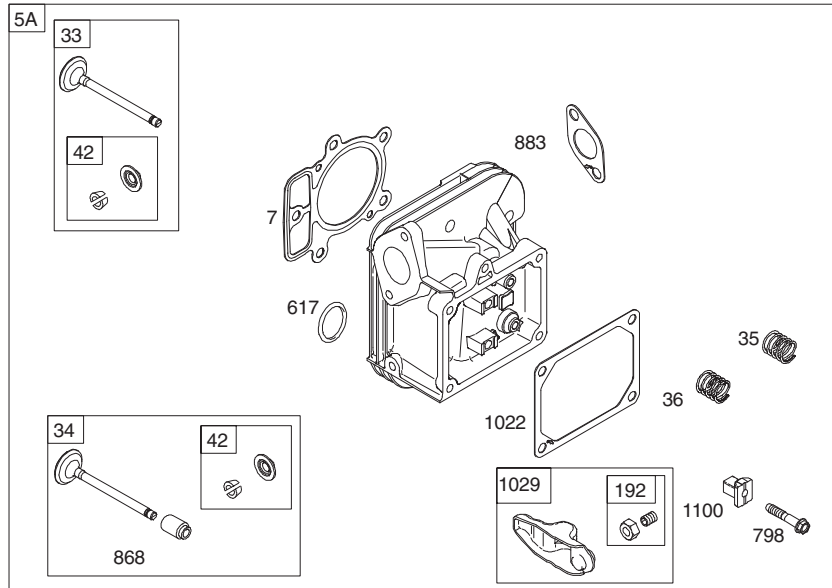
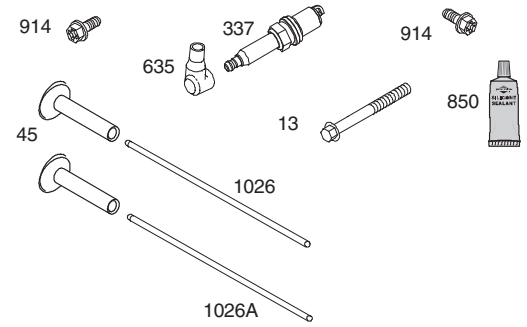
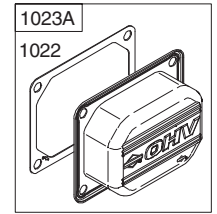
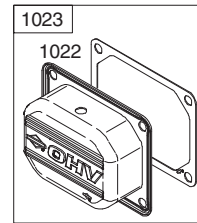
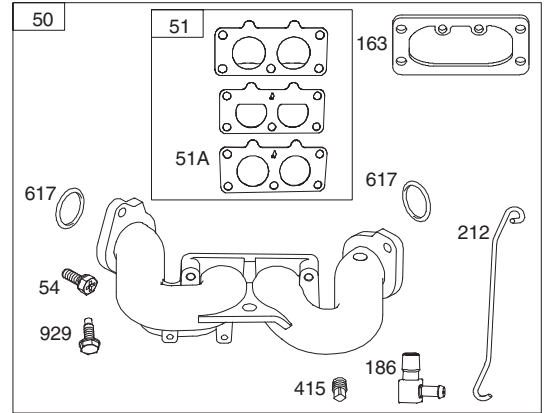
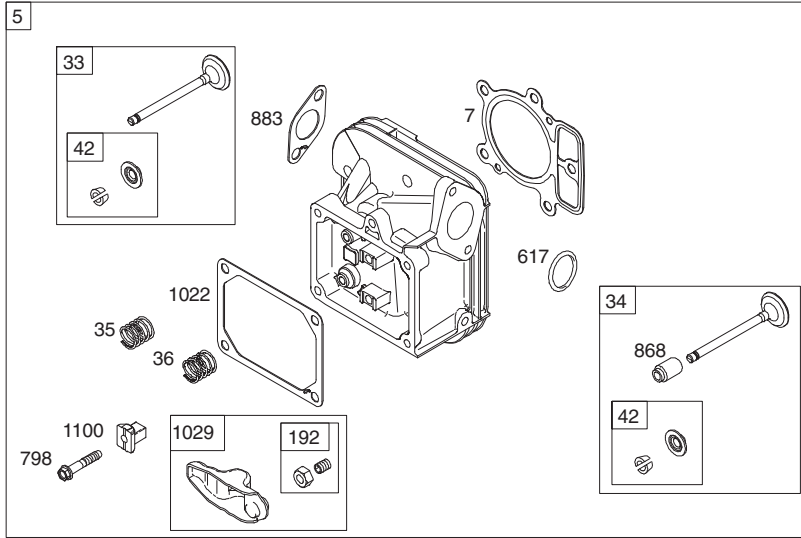

TRACTOR - - MODEL NUMBER 944.600090

B&S ENGINE - MODEL NUMBER 445877, TYPE NUMBER 0760-B1

KEY NO.	PART NO.	DESCRIPTION	KEY NO.	PART NO.	DESCRIPTION
1	793564	Cylinder Assembly	146	690979	Key-Timing
2	797673	Kit-Bushing/Seal (Magneto Side)	150	690995	Gasket-Nozzle
3	391086s	Seal-Oil (Magneto Side)	163	691001	Gasket-Air Cleaner
4	796307	Sump-Engine	165	693148	Nut (Ring Gear)
5	793558	Head-Cylinder (Cylinder #1)	187	791766	Line-Fuel (Cut to Required Length)
5A	793559	Head-Cylinder (Cylinder #2)	188	697551	Screw (Control Bracket)
7	693997	Gasket-Cylinder Head	192	690083	Adjuster-Rocker Arm
8	792185	Breather Assembly	197	697820	Screw (Back Plate)
9	690937	Gasket-Breather	209	793339	Spring-Governor (Light Green)
10	697551	Screw (Breather Assembly)	211	691019	Spring-Governed Idle
11	792184	Tube-Breather	212	695238	Link-Throttle
12	697227	Gasket-Crankcase	213	691021	Bracket-Choke Control
13	791130	Screw (Cylinder Head)	216	691022	Link-Choke
15	690946	Plug-Oil Drain	217	695409	Spring-Choke Return
16	790132	Crankshaft	219	793338	Gear-Governor
20	795387	Seal-Oil (PTO Side)	220	690412	Washer (Governor Gear)
22	694966	Screw (Crankcase Cover/Sump)	221	841026	Cup-Governor
23	691053	Flywheel	222	698761	Bracket-Control
24	222698s	Key-Flywheel	227	796223	Lever-Governor Control
25	793560	Piston Assembly (Standard)	231	690718	Screw (Choke Valve)
25	793563	Piston Assembly (.020" Oversize)	240	691035	Filter-Fuel
26	793561	Ring Set (Standard)	250	690957	Retainer-Breather
26	792073	Ring Set (.020" Oversize)	252	794389	Collector-Oil
27	690975	Lock-Piston Pin	265	691024	Clamp-Casing
28	690229	Pin-Piston	267	792629	Screw (Casing Clamp)
29	699699	Rod-Connecting	276	695410	Washer-Sealing
32	690976	Screw (Connecting Rod)	276A	690997	Washer-Sealing
33	793557	Valve-Exhaust	276B	794271	Washer-Sealing
34	793556	Valve-Intake	278	792651	Washer (Governor Control Lever)
35	694865	Spring-Valve (Intake)	287	691108	Screw (Dipstick Tube)
36	694865	Spring-Valve (Exhaust)	304	797406	Housing-Blower
42	499586	Keeper-Valve	305	691005	Screw (Blower Housing)
45	690977	Tappet-Valve	305A	790690	Screw (Blower Housing to Intake Elbow)
46	792555	Gear-Cam	306	796852	Shield-Cylinder (Cylinder #1)
48	698173	Short Block	306A	793205	Shield-Cylinder (Cylinder #2)
50	695241	Manifold-Intake	307	691003	Screw (Air Guide Cover) (10-24x.437)
51	795123	Gasket-Intake	307A	697551	Screw (Air Guide Cover) (1/4-20x.625)
51A	690950	Gasket-Intake	309	497595	Motor-Starter
51	690949	Gasket-Intake	310	690323	Screw (Starter Motor)
53	690951	Stud (Carburetor)	311	497608	Brush Set
54	699816	Screw (Intake Manifold)	332	691059	Nut (Flywheel)
73	494439	Screen-Rotating	333	691060	Armature-Magneto
74	698425	Screw (Rotating Screen)	334	691061	Screw (Magneto Armature)
75	691056	Washer (Flywheel)	337	491055s	Plug-Spark
95	690718	Screw (Throttle Valve)	358	694012	Gasket Set-Engine
98	699721	Kit-Idle Speed	385	797409	Screw (Fuel Pump)
104	694918	Pin-Float Hinge	387	808656	Pump-Fuel
105	797410	Valve-Float Needle	404	690442	Washer (Governor Crank)
108	699723	Valve-Choke	415	690283	Plug (Oil Pressure Switch)
117	791501	Jet-Main (Standard) (Left Jet)	418	795912	Plate-Carburetor
117A	791502	Jet-Main (Standard) (Right Jet)	431	790816	Elbow-Intake
118	695415	Jet-Main (High Altitude)LeftJet)	445	499486s	Filter-Air Cleaner Cartridge
118A	843099	Jet-Main (High Altitude) (Right Jet)	447	691003	Screw (Air Guide Cover) (10-24x.437)
121	797890	Kit-Carburetor Overhaul	447A	697551	Screw (Air Guide Cover) (1/4-20x.625)
125	791230	Carburetor (Primer System)	467	691008	Knob-Air Cleaner
130	690993	Valve-Throttle	474	696458	Alternator
131	499805	Kit-Throttle Shaft			
133	699724	Float-Carburetor			
135	699729	Tube-Fuel Transfer			
137	690994	Gasket-Float Bowl			
141	699722	Kit-Choke Shaft			
142	699726	Nozzle-Carburetor			

TRACTOR - - MODEL NUMBER 944.600090

B&S ENGINE - MODEL NUMBER 445877, TYPE NUMBER 0760-B1

KEY NO.	PART NO.	DESCRIPTION	KEY NO.	PART NO.	DESCRIPTION
501	797375	Regulator	943A	796222	Seal-O Ring (Oil Pump Cover)
505	691029	Nut (Governor Control Lever)	947	841546	Solenoid-Fuel
510	696541	Drive-Starter	965	499613	Cover-Oil Pump
513	692024	Clutch-Drive	965A	796221	Cover-Oil Pump
523	691036	Dipstick	967	273638s	Filter-Pre Cleaner
524	691032	Seal-Dipstick Tube	968	791242	Cover-Air Cleaner
525	691037	Tube-Dipstick	975	793592	Bowl-Float
526	697551	Screw (Regulator)	987	691000	Seal-Throttle Shaft
544	692034	Armature-Starter (For Replacement, Order Starter Motor 497595, Reference 309)	1005	791236	Fan-Flywheel
552	690552	Bushing-Governor Crank	1013	690954	Nipple-Oil Filter
552A	690553	Bushing-Governor Crank	1017	690770	Screen-Oil Pump
562	690311	Screw (Governor Control Lever)	1017A	796214	Screen-Oil Pump
573	790444	Plate-Back	1022	690971	Gasket-Rocker Cover
579	691029	Nut (Starter Cable)	1023	793146	Cover-Rocker (Cylinder #1)
601	691038	Clamp-Hose (Black)	1023A	499600	Cover-Rocker (Cylinder #2)
615	698290	Retainer-Governor Shaft	1024	794644	Pump-Oil
616	691045	Crank-Governor	1024A	796220	Pump-Oil
617	697891	Seal-O Ring (Intake Manifold) (Red)	1026	690981	Rod-Push (Steel)
633	690998	Seal-Choke/Throttle Shaft (Choke Shaft)	1026A	690982	Rod-Push (Aluminum)
633A	699813	Seal-Choke/Throttle Shaft	1027	492932s	Filter-Oil
635	66538s	Boot-Spark Plug	1029	690972	Arm-Rocker
654	690958	Nut (Carburetor)	1036		Label-Emissions (Available from a Briggs & Stratton Authorized Dealer)
668	691215	Spacer (Rotating Screen)	1040	791237	Plate-Trim
668A	691500	Spacer (Rotating Screen)	1051	691265	Ring-Retaining (Starter Drive)
672	690234	Gasket-Carburetor Plate	1054	280275	Tie-Cable
691	790574	Seal-Governor Shaft	1058	277103	Operator's Manual
695	693149	Screw (Ring Gear)	1059	698516	Kit-Screw/Washer (Alternator)
697	690372	Screw (Drive Cap)	1070	791680	Screw (Flywheel Fan)
703	691010	Clip	1090	691293	Retainer-Brush
718	690959	Pin-Locating	1095	694013	Gasket Set-Valve
726	499612	Gear-Ring	1100	791959	Pivot-Rocker Arm
729	797454	Clip-Wire	1119	691183	Screw (Alternator)
741	690980	Gear-Timing	1123	841653	Seal-O Ring (Solenoid Retainer)
742	690328	Retainer-E Ring (Governor Crank)	1123A	690987	Seal-O Ring (Solenoid Retainer)
750	696999	Screw (Oil Pump Cover)	1124	690988	Seal-O Ring (Fuel Transfer Tube)
750A	796208	Screw (Oil Pump Cover)	1126	690991	Screw (Fuel Transfer Tube)
783	695708	Gear-Pinion	1127	695407	Screw (Fuel Bowl)
789	797424	Harness-Wiring	1128	690990	Screw (Carburetor Nozzle)
797	693167	Nut (Brush Retainer)	1169	690990	Screw (Carburetor Plate)
798	697890	Screw (Rocker Arm)	1329	44Q777-0136-G1	Replacement Engine
801	691283	Cap-Drive	1330	273521	Repair Manual
802	691286	Cap-End	1353	699725	Seal-O Ring (Fuel Transfer Tube Extension)
803		Housing-Starter (For Replacement, Order Starter Motor 497595, Reference 309)			
842	691031	Seal-O Ring (Dipstick Tube)			Engine Gasket Set Key No. 358
847	499602	Dipstick/Tube Assembly			Valve Gasket Set Key No. 1095
850	100106	Sealant-Liquid (Rocker Cover Gasket and Breather Gasket)			Carburetor Overhaul Kit Key No. 121
851	493880s	Terminal-Spark Plug			
865	691015	Cover-Air Guide (Valley)			
868	690968	Seal-Valve			
883	690970	Gasket-Exhaust			
914	691127	Screw (Rocker Cover)			
918	797408	Line-Vacuum			
929	695239	Screw (Choke Control Bracket)			
943	690589	Seal-O Ring (Oil Pump Cover)			

NOTE: All component dimensions give in U.S. inches
1 inch = 25.4 mm

SERVICE NOTES

GENERAL: Craftsman products are warranted to be free from defects in materials or workmanship for a specific time period as set-out below (the "Warranty Period"). Warranties extend to the original purchaser of a Craftsman product only. Purchases made through an online auction or through any website other than www.sears.ca are excluded. The relevant Warranty Period commences on the original date of purchase. Within this period, SEARS CANADA, Inc. will, at its sole option, repair or replace any products or components which fail in normal use. Such repairs or replacement will be made at no charge to the customer for parts or labor, provided that the customer shall be responsible for any transportation cost.

EXCLUSIONS: This warranty does not cover failures due to normal wear, abuse, misuse, neglect (including but not limited to the use of stale fuel, dirt, abrasives, moisture, rust, corrosion, or any adverse reaction due to improper storage or use habits), improper maintenance or failure to follow maintenance guidelines and/or instructions, failure to operate the product in accordance with the owner's manual or any additional instructions or information provided at the time of purchase or in subsequent communications with the original purchaser, accident or unauthorized alterations or repairs made or attempted by others. Also excluded from warranty coverage - except as provided below - are the following: maintenance, adjustments, components subject to wear including but not limited to: cosmetic components, belts, blades, blade adapters, bulbs, tires, filters, guide bars, lubricants, seats, grips, recoil assy's, saw chains and bars, trimmer lines and spools, spark plugs, starter ropes and tines, and discoloration resulting from ultraviolet light. Any product missing the model and/or serial number identification label will be disqualified from coverage under this warranty.

REPAIRS: Repairs have a 90 day warranty. If the defective product is still within the Warranty Period, then the new warranty is 90 days from the date of repair or to the end of the original Warranty Period, whichever period is longer.

DISCLAIMERS: THE WARRANTIES AND REMEDIES CONTAINED HEREIN ARE EXCLUSIVE AND IN LIEU OF ALL OTHER WARRANTIES, WHETHER ORAL OR WRITTEN (OTHER THAN AS STATED HEREIN), AND WHETHER EXPRESS, IMPLIED OR STATUTORY, INCLUDING BUT NOT LIMITED TO ANY. THIS WARRANTY GIVES YOU SPECIFIC LEGAL RIGHTS, WHICH MAY VARY FROM PROVINCE TO PROVINCE.

IN NO EVENT SHALL SEARS BE LIABLE FOR ANY INCIDENTAL, SPECIAL, INDIRECT OR CONSEQUENTIAL DAMAGES, WHETHER RESULTING FROM THE USE, MISUSE OR INABILITY TO USE THE PRODUCT OR FROM DEFECTS IN THE PRODUCT. THE EXCLUSIONS IN THIS PARAGRAPH SHALL NOT APPLY IN JURISDICTIONS WHERE APPLICABLE LAW DOES NOT ALLOW FOR THE EXCLUSION OF INCIDENTAL OR CONSEQUENTIAL DAMAGES. IN SUCH JURISDICTIONS, THIS PARAGRAPH SHALL NOT APPLY, BUT THE REMAINING PROVISIONS OF THIS DOCUMENT SHALL REMAIN VALID.

SEARS retains the exclusive right to repair or replace the product or offer a full refund of the purchase price at its sole discretion. SUCH REMEDY SHALL BE YOUR SOLE AND EXCLUSIVE REMEDY FOR ANY BREACH OF WARRANTY.

CUSTOMER RESPONSIBILITIES: In addition to complying with all suggested maintenance guidelines and instructions, customers' obligations shall include but shall not be limited to: operating the product in accordance with the owner's manual or any additional instructions or information provided at the time of purchase or in subsequent communications to the purchaser from time to time, exhibit reasonable care in the use, operation, maintenance, general upkeep and storage of the product. Failure to comply with these requirements will void any applicable warranty.

LIST OF APPLICABLE WARRANTY PERIODS: The following list contains the applicable Warranty Period for your Craftsman product and is based on a combination of the type of product or component and the intended and actual use of the product or component:

1. **90 DAYS:** Craftsman products intended for use or actually used for commercial, institutional, professional or income-producing purposes
2. **2 YEARS:** Craftsman riding lawn mowers, yard and garden tractors, walk behind mowers, tillers, brush cutters, snow blowers, handheld blowers, backpack blowers, hedge trimmers and electrical products for noncommercial, nonprofessional, non-institutional, or non-income-producing use, except for those components which are part of engine systems manufactured by third party engine manufacturers for which the purchase has received an separate warranty with product information supplied at the time of purchase.
3. **1 YEAR:** Craftsman power cutters, stump grinders, pole pruners, gas chain saws, electric chain saws, trimmer attachments, baggers and pole saws for noncommercial, nonprofessional, non-institutional, or non-income-producing use.
4. **90 DAYS:** All defective batteries, which will be replaced during this 90-day Warranty Period.
5. **60 DAYS:** Additional Warranty Period of 60 days will apply to adjustments and worn products or components BUT DOES NOT INCLUDE WEAR OR ADJUSTMENTS for products used for commercial, institutional, professional or income-producing purposes. Wear items include but are not limited to: belts, blades, tires, spark plugs, air filters, chains, shear bolts, skid plates, scraper bars, drift cutters, ropes, tines, collection bags and pulleys.

As the Warranty Period runs from the date of purchase and NOT from the date that a product is delivered, opened, assembled or first used, please ensure during this time period that your product or component has been assembled and tested for correction operation regardless of when you intend to actually use it. Claims made after the Warranty Period has expired will not be honored.

PROOF OF PURCHASE/DOCUMENTATION: Warranty coverage is conditioned upon the original purchaser furnishing SEARS CANADA or its authorized third party service provider if applicable, with the original sales receipt or other adequate written proof of the original purchase date and identification of the product. In the event that the original purchaser is unable to provide a company of the original sales receipt, SEARS CANADA Inc. reserves the right to determine in its sole discretion what other written proof of the original purchase date and identification of the product is acceptable.

SUGGESTED GUIDE FOR SIGHTING SLOPES FOR SAFE OPERATION

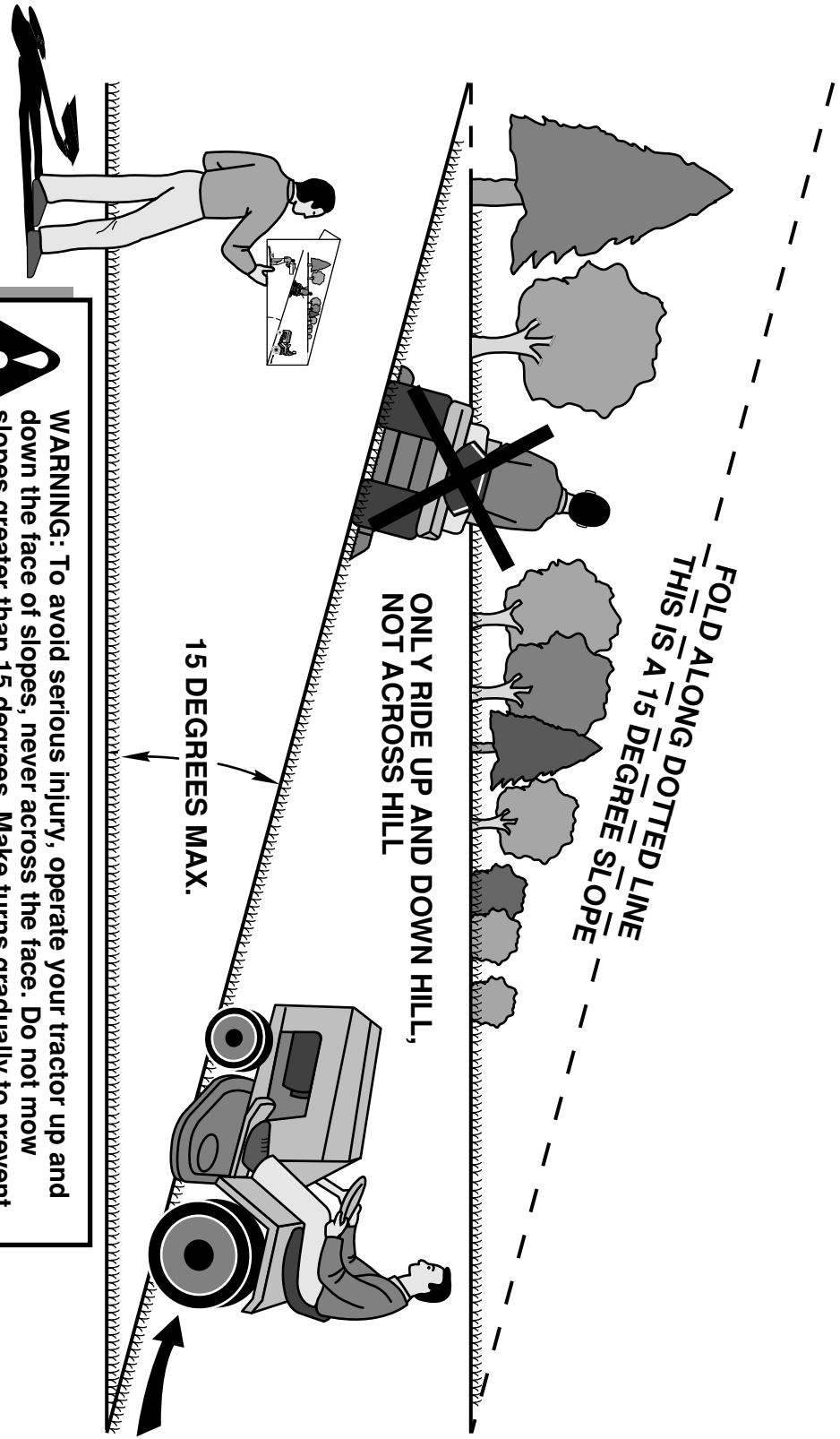

 **WARNING:** To avoid serious injury, operate your tractor up and down the face of slopes, never across the face. Do not mow slopes greater than 15 degrees. Make turns gradually to prevent tipping or loss of control. Exercise extreme caution when changing direction on slopes.

1. Fold this page along dotted line indicated above.
2. Hold page before you so that its left edge is vertically parallel to a tree trunk or other upright structure.
3. Sight across the fold in the direction of hill slope you want to measure.
4. Compare the angle of the fold with the slope of the hill.

Get it fixed, at your home or ours!

Just Call:

1-800-4-MY-HOME[®]

(1-800-469-4663)

24 hours a day, 7 days a week

For the repair of major brand appliances **in your own home...**
no matter who made it, no matter who sold it!

For your nearest **Sears Parts and Service** location,
to bring in products like vacuums, lawn equipment and electronics.

For **Sears Parts & Service**, to order the replacement parts,
accessories and owner's manuals that you need to do-it-yourself.

www.sears.ca

To purchase or inquire about a Sears Maintenance Agreement, call:

1-800-361-6665

9 a.m. – 11 p.m. Mon. – Fri., EST, 9 a.m. – 4 p.m. Sat.

Pour service en français:

1-800-LE-FOYER^{MC}

(1-800-533-6937)

www.sears.ca



® / TM Trademarks of Sears, Roebuck and Co. used under license by Sears Canada

^{MD} Marque déposée / ^{MC} Marque de commerce de Sears, Roebuck and Co. utilisée en vertu d'une licence de Sears Canada