

**SEARS**  
OWNER'S  
MANUAL

**MODEL NO.  
944.600100**

**Important:  
Read and follow  
all Safety Rules  
and Instructions  
Before Operating  
This Equipment**

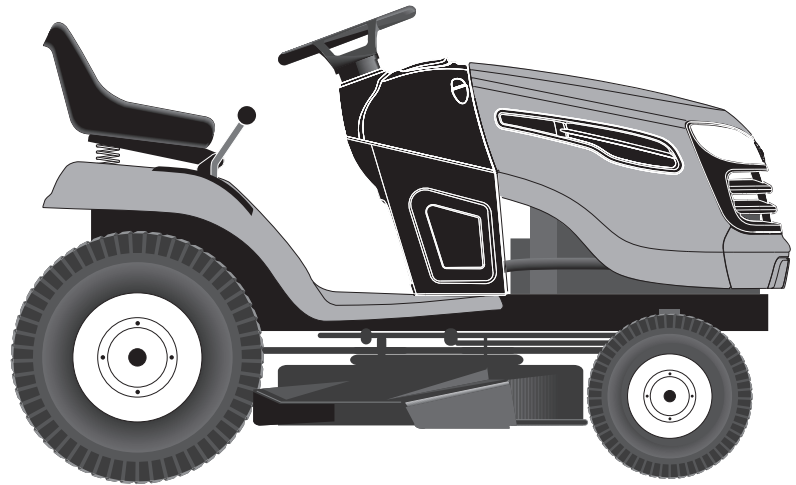

**CRAFTSMAN®**

**19.5 HP\*  
ELECTRIC START  
42" MOWER  
AUTOMATIC TRANSMISSION  
LAWN TRACTOR**

- **Assembly**
- **Operation**
- **Maintenance**
- **Service and Adjustments**
- **Repair Parts**

\*As rated by the engine manufacturer

**Sears Canada, Inc., Toronto, Ontario M5B 2B8**

**434833**



# SAFETY RULES



## Safe Operation Practices for Ride-On Mowers

**DANGER: THIS CUTTING MACHINE IS CAPABLE OF AMPUTATING HANDS AND FEET AND THROWING OBJECTS. FAILURE TO OBSERVE THE FOLLOWING SAFETY INSTRUCTIONS COULD RESULT IN SERIOUS INJURY OR DEATH.**



**WARNING: In order to prevent accidental starting when setting up, transporting, adjusting or making repairs, always disconnect spark plug wire and place wire where it cannot contact spark plug.**



**WARNING: Do not coast down a hill in neutral, you may lose control of the tractor.**



**WARNING: Tow only the attachments that are recommended by and comply with specifications of the manufacturer of your tractor. Use common sense when towing. Operate only at the lowest possible speed when on a slope. Too heavy of a load, while on a slope, is dangerous. Tires can lose traction with the ground and cause you to lose control of your tractor.**



### WARNING



**Engine exhaust, some of its constituents, and certain vehicle components contain or emit chemicals known to the State of California to cause cancer and birth defects or other reproductive harm.**



### WARNING



**Battery posts, terminals and related accessories contain lead and lead compounds, chemicals known to the State of California to cause cancer and birth defects or other reproductive harm. Wash hands after handling.**

## I. GENERAL OPERATION

- Read, understand, and follow all instructions on the machine and in the manual before starting.
- Do not put hands or feet near rotating parts or under the machine. Keep clear of the discharge opening at all times.
- Only allow responsible adults, who are familiar with the instructions, to operate the machine.
- Clear the area of objects such as rocks, toys, wire, etc., which could be picked up and thrown by the blades.
- Be sure the area is clear of bystanders before operating. Stop machine if anyone enters the area.
- Never carry passengers.
- Do not mow in reverse unless absolutely necessary. Always look down and behind before and while backing.
- Never direct discharged material toward anyone. Avoid discharging material against a wall or obstruction. Material may ricochet back toward the operator. Stop the blades when crossing gravel surfaces.
- Do not operate machine without the entire grass catcher, discharge chute, or other safety devices in place and working.

- Slow down before turning.
- Never leave a running machine unattended. Always turn off blades, set parking brake, stop engine, and remove keys before dismounting.
- Disengage blades when not mowing. Shut off engine and wait for all parts to come to a complete stop before cleaning the machine, removing the grass catcher, or unclogging the discharge chute.
- Operate machine only in daylight or good artificial light.
- Do not operate the machine while under the influence of alcohol or drugs.
- Watch for traffic when operating near or crossing roadways.
- Use extra care when loading or unloading the machine into a trailer or truck.
- Always wear eye protection when operating machine.
- Data indicates that operators, age 60 years and above, are involved in a large percentage of riding mower-related injuries. These operators should evaluate their ability to operate the riding mower safely enough to protect themselves and others from serious injury.
- Follow the manufacturer's recommendation for wheel weights or counterweights.
- Keep machine free of grass, leaves or other debris build-up which can touch hot exhaust / engine parts and burn. Do not allow the mower deck to plow leaves or other debris which can cause build-up to occur. Clean any oil or fuel spillage before operating or storing the machine. Allow machine to cool before storage.

## II. SLOPE OPERATION

Slopes are a major factor related to loss of control and tip-over accidents, which can result in severe injury or death. Operation on all slopes requires extra caution. If you cannot back up the slope or if you feel uneasy on it, do not mow it.

- Mow up and down slopes, not across.
- Watch for holes, ruts, bumps, rocks, or other hidden objects. Uneven terrain could overturn the machine. Tall grass can hide obstacles.
- Choose a low ground speed so that you will not have to stop or shift while on the slope.
- Do not mow on wet grass. Tires may lose traction. Always keep the machine in gear when going down slopes. Do not shift to neutral and coast downhill.
- Avoid starting, stopping, or turning on a slope. If the tires lose traction, disengage the blades and proceed slowly straight down the slope.
- Keep all movement on the slopes slow and gradual. Do not make sudden changes in speed or direction, which could cause the machine to roll over.
- Use extra care while operating machine with grass catchers or other attachments; they can affect the stability of the machine. Do no use on steep slopes.
- Do not try to stabilize the machine by putting your foot on the ground.
- Do not mow near drop-offs, ditches, or embankments. The machine could suddenly roll over if a wheel is over the edge or if the edge caves in.



# SAFETY RULES

## Safe Operation Practices for Ride-On Mowers



### III. CHILDREN

Tragic accidents can occur if the operator is not alert to the presence of children. Children are often attracted to the machine and the mowing activity. Never assume that children will remain where you last saw them.

- Keep children out of the mowing area and in the watchful care of a responsible adult other than the operator.
- Be alert and turn machine off if a child enters the area.
- Before and while backing, look behind and down for small children.
- Never carry children, even with the blades shut off. They may fall off and be seriously injured or interfere with safe machine operation. Children who have been given rides in the past may suddenly appear in the mowing area for another ride and be run over or backed over by the machine.
- Never allow children to operate the machine.
- Use extra care when approaching blind corners, shrubs, trees, or other objects that may block your view of a child.

### IV. TOWING

- Tow only with a machine that has a hitch designed for towing. Do not attach towed equipment except at the hitch point.
- Follow the manufacturer's recommendation for weight limits for towed equipment and towing on slopes.
- Never allow children or others in or on towed equipment.
- On slopes, the weight of the towed equipment may cause loss of traction and loss of control.
- Travel slowly and allow extra distance to stop.

### V. SERVICE

#### SAFE HANDLING OF GASOLINE

To avoid personal injury or property damage, use extreme care in handling gasoline. Gasoline is extremely flammable and the vapors are explosive.

- Extinguish all cigarettes, cigars, pipes, and other sources of ignition.
- Use only approved gasoline container.
- Never remove gas cap or add fuel with the engine running. Allow engine to cool before refueling.
- Never fuel the machine indoors.
- Never store the machine or fuel container where there is an open flame, spark, or pilot light such as on a water heater or other appliances.
- Never fill containers inside a vehicle or on a truck or trailer bed with plastic liner. Always place containers on the ground away from your vehicle when filling.
- Remove gas-powered equipment from the truck or trailer and refuel it on the ground. If this is not possible, then refuel such equipment with a portable container, rather than from a gasoline dispenser nozzle.
- Keep the nozzle in contact with the rim of the fuel tank or container opening at all times until fueling is complete. Do not use a nozzle lock-open device.
- If fuel is spilled on clothing, change clothing immediately.
- Never overfill fuel tank. Replace gas cap and tighten securely.

#### GENERAL SERVICE

- Never operate machine in a closed area.
- Keep all nuts and bolts tight to be sure the equipment is in safe working condition.
- Never tamper with safety devices. Check their proper operation regularly.
- Keep machine free of grass, leaves, or other debris build-up. Clean oil or fuel spillage and remove any fuel-soaked debris. Allow machine to cool before storing.
- If you strike a foreign object, stop and inspect the machine. Repair, if necessary, before restarting.
- Never make any adjustments or repairs with the engine running.
- Check grass catcher components and the discharge chute frequently and replace with manufacturer's recommended parts, when necessary.
- Mower blades are sharp. Wrap the blade or wear gloves, and use extra caution when servicing them.
- Check brake operation frequently. Adjust and service as required.
- Maintain or replace safety and instruction labels, as necessary.



- Be sure the area is clear of bystanders before operating. Stop machine if anyone enters the area.
- Never carry passengers.
- Do not mow in reverse unless absolutely necessary. Always look down and behind before and while backing.
- Never carry children, even with the blades shut off. They may fall off and be seriously injured or interfere with safe machine operation. Children who have been given rides in the past may suddenly appear in the mowing area for another ride and be run over or backed over by the machine.
- Keep children out of the mowing area and in the watchful care of a responsible adult other than the operator.
- Be alert and turn machine off if a child enters the area.
- Before and while backing, look behind and down for small children.
- Mow up and down slopes (15° Max), not across.
- Choose a low ground speed so that you will not have to stop or shift while on the slope.
- Avoid starting, stopping, or turning on a slope. If the tires lose traction, disengage the blades and proceed slowly straight down the slope.
- If machine stops while going uphill, disengage blades, shift into reverse and back down slowly.
- Do not turn on slopes unless necessary, and then, turn slowly and gradually downhill, if possible.

<b>PRODUCT SPECIFICATIONS</b>	
GASOLINE CAPACITY AND TYPE:	1.50 GALLONS UNLEADED REGULAR
OIL TYPE (API: SF-SJ):	SAE 30 (above 32°F) SAE 5W-30 (below 32°F) SYNTHETIC (below 0°F)
Your tractor was shipped from the factory with non-synthetic SAE 10W-30 motor oil.	
OIL CAPACITY:	W/ FILTER: 56 Oz W/O FILTER: 48 Oz
SPARK PLUG:	RC12YC (GAP: .030")
GROUND SPEED (MPH):	Forward: 0-5.2 Reverse: 0-2.9
CHARGING SYSTEM:	3 AMPS BATTERY 5 AMPS HEADLIGHTS
BATTERY:	AMP/HR: 28 MIN. CCA: 230 CASE SIZE: U1R
BLADE BOLT TORQUE:	45-55 FT. LBS.

**CONGRATULATIONS** on your purchase of a new Tractor. It has been designed, engineered and manufactured to give you the best possible dependability and performance.

Should you experience any problem you cannot easily remedy, please contact your nearest authorized service center/department. We have competent, well-trained representatives and the proper tools to service or repair this tractor.

Please read and retain this manual. The instructions will enable you to assemble and maintain your tractor properly. Always observe the "SAFETY RULES".

## MAINTENANCE AGREEMENT

A Maintenance Agreement is available on this product. Contact your nearest Sears store for details.

## CUSTOMER RESPONSIBILITIES

- Read and observe the safety rules.
- Follow a regular schedule in maintaining, caring for and using your tractor.
- Follow the instructions under "Maintenance" and "Storage" sections of this owner's manual.

**WARNING:** This tractor is equipped with an internal combustion engine and should not be used on or near any unimproved forest-covered, brush-covered or grass-covered land unless the engine's exhaust system is equipped with a spark arrester meeting applicable local or state laws (if any). If a spark arrester is used, it should be maintained in effective working order by the operator.

A spark arrester for the muffler is available through your nearest authorized service center/department (See REPAIR PARTS section of this manual).

---

# TABLE OF CONTENTS

---

SAFETY RULES .....	2-3
PRODUCT SPECIFICATIONS.....	4
CUSTOMER RESPONSIBILITIES.....	4
ASSEMBLY .....	6-8
OPERATION .....	9-15
MAINTENANCE SCHEDULE .....	16
MAINTENANCE .....	16-20
SERVICE AND ADJUSTMENTS .....	21-26

STORAGE.....	27
TROUBLESHOOTING.....	28-29
REPAIR PARTS - TRACTOR .....	30-47
REPAIR PARTS - TRANSMISSION .....	48-49
REPAIR PARTS - ENGINE .....	50-53
WARRANTY.....	54
PARTS ORDERING/SERVICE .....	BACK COVER

# UNASSEMBLED PARTS

## Steering Wheel

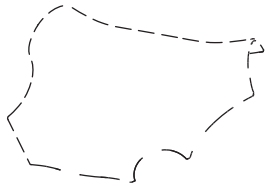

Steering Wheel Insert

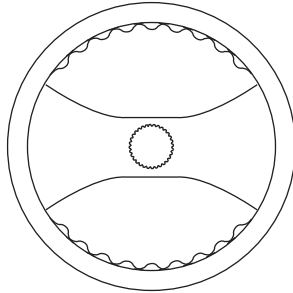

Steering Wheel

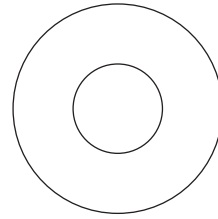

(1) Large Flat Washer

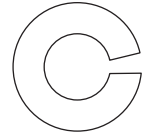

(1) Lock Washer

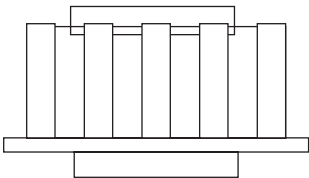

Steering Wheel Adapter

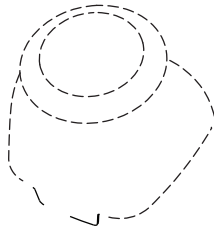

Steering Boot

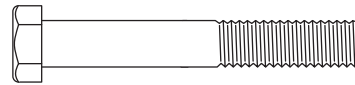

(1) Hex Bolt



Steering Extension Shaft

## Seat

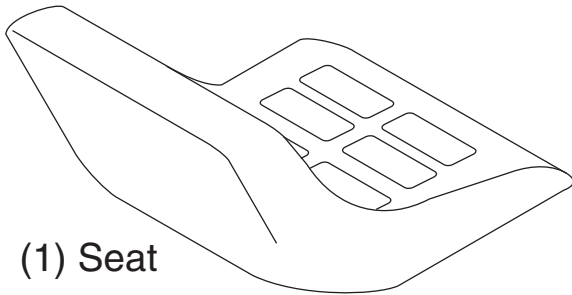

(1) Seat

(1) Washer

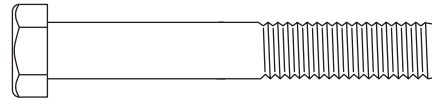
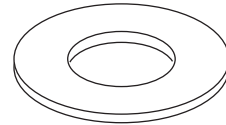

(1) Hex Bolt

## Slope Sheet

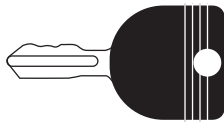

Key(s)

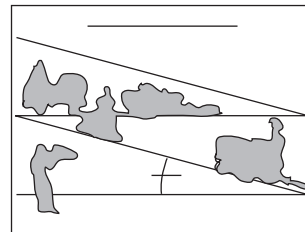

# ASSEMBLY

Your new tractor has been assembled at the factory with exception of those parts left unassembled for shipping purposes. To ensure safe and proper operation of your tractor all parts and hardware you assemble must be tightened securely. Use the correct tools as necessary to ensure proper tightness.

## TOOLS REQUIRED FOR ASSEMBLY

A socket wrench set will make assembly easier. Standard wrench sizes are listed.

- |                                 |                     |
|---------------------------------|---------------------|
| (2) 7/16" wrenches              | Utility knife       |
| (1) 1/2" wrench                 | Tire pressure gauge |
| (1) 3/4" wrench                 | Pliers              |
| (1) 3/4" socket w/drive ratchet |                     |

When right or left hand is mentioned in this manual, it means when you are in the operating position (seated behind the steering wheel).

## TO REMOVE TRACTOR FROM CARTON

### UNPACK CARTON

- Remove all accessible loose parts and parts cartons from carton .
- Cut along dotted lines on all four panels of carton. Remove end panels and lay side panels flat.
- Check for any additional loose parts or cartons and remove.

## BEFORE REMOVING TRACTOR FROM SKID

### TO CHECK BATTERY (See Fig. 1)

- Lift seat to raised position.

**NOTE:** If this battery is put into service after month and year indicated on label (label is located between terminals) charge battery for minimum of one hour at 6-10 amps. (See "BATTERY" in Maintenance section of this manual for charging instructions).

- For battery and battery cable installation see "REPLACING BATTERY" in the "Service and Adjustments" section in this manual.

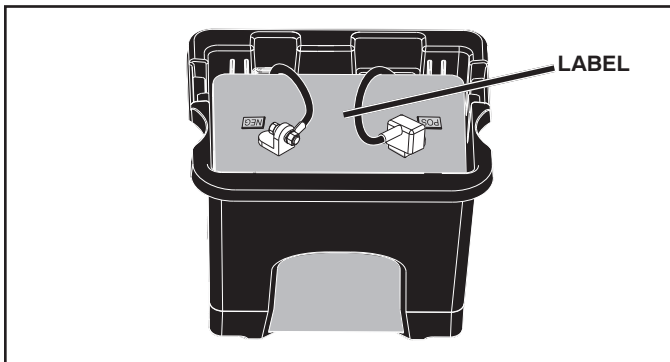

Fig. 1

## TO INSTALL STEERING WHEEL (See Fig. 2)

### ASSEMBLE EXTENSION SHAFT AND BOOT

- Slide extension shaft onto lower steering shaft.
- Place tabs of steering boot over tab slots in dash and push down to secure.

### INSTALL STEERING WHEEL

- Position front wheels of the tractor so they are pointing straight forward.
- Remove steering wheel adapter from steering wheel and slide adapter onto steering shaft extension.
- Position steering wheel so cross bars are horizontal (left to right) and slide inside boot and onto adapter.
- Assemble large flat washer, lock washer, hex bolt and tighten securely.
- Snap steering wheel insert into center of steering wheel.
- Remove protective materials from tractor hood and grill.

**IMPORTANT:** CHECK FOR AND REMOVE ANY STAPLES IN SKID THAT MAY PUNCTURE TIRES WHERE TRACTOR IS TO ROLL OFF SKID.

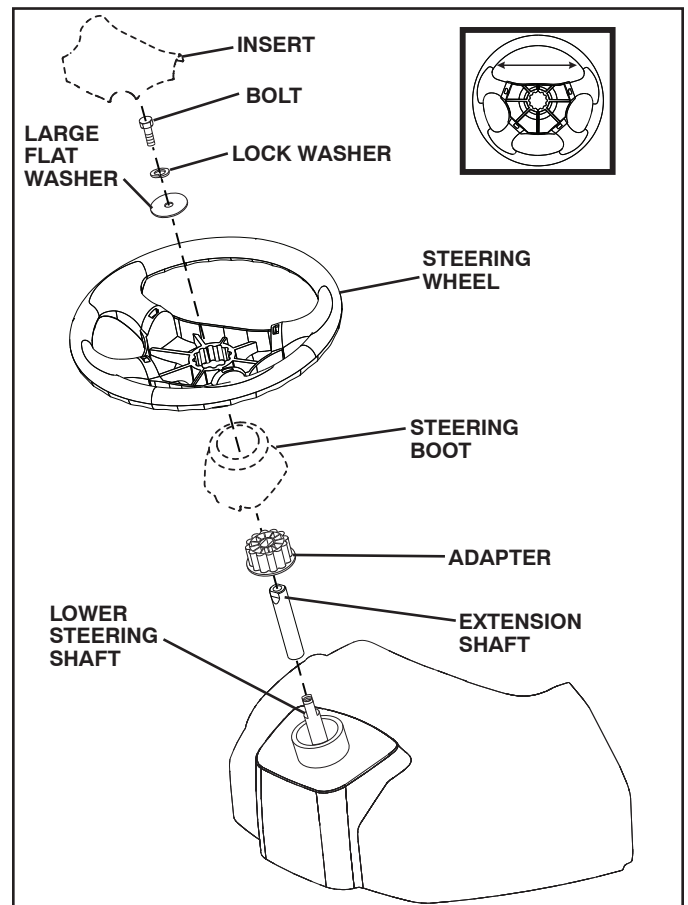

Fig. 2

# ASSEMBLY

## INSTALL SEAT (See Figs. 3 and 4)

- Remove bolt and flat washer securing seat to cardboard packing and set aside for assembly of seat to tractor. Remove the cardboard packing and discard.
- Connect switch to seat.
- Place seat on seat pan so all three (3) bottom pads are positioned over large slotted holes in pan.

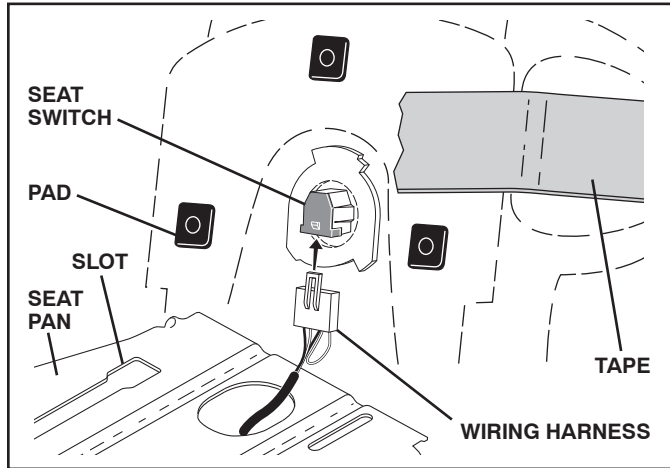

FIG. 3

- Push down on seat to engage pads in slots and pull seat towards rear of tractor.
- Raise seat and tighten bolt securely.
- Remove tape and discard.
- Lower seat into operating position and sit on seat. Press clutch/brake pedal all the way down. If operating position is not comfortable, adjust seat.

## TO ADJUST SEAT (See Fig. 4)

- Grasp adjustment handle and pull up, slide seat to desired position and release adjustment handle.

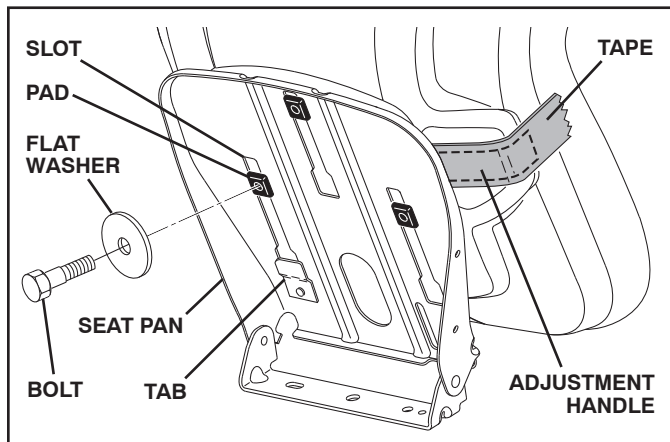

Fig. 4

**NOTE:** You may now roll your tractor off the skid. Follow the instructions to remove the tractor from the skid.

**WARNING:** Before starting, read, understand and follow all instructions in the Operation section of this manual. Be sure tractor is in a well-ventilated area. Be sure the area in front of tractor is clear of other people and objects.

## INSTALL MULCHER PLATE (See Fig. 5) (If previously removed)

- Raise and hold deflector shield in upright position.
- Place slot in mulcher plate over tab on mower and position plate over mower opening as shown.
- Hook front latch into hole on front of mower deck.
- Hook rear latch into hole on back of mower deck.



**CAUTION:** Do not remove deflector shield from mower.

## TO CONVERT TO BAGGING OR DISCHARGING

Simply remove mulcher plate and store in a safe place. Your mower is now ready for discharging or installation of optional grass catcher accessory.

**NOTE:** It is not necessary to change blades. The mulcher blades are designed for discharging and bagging also.

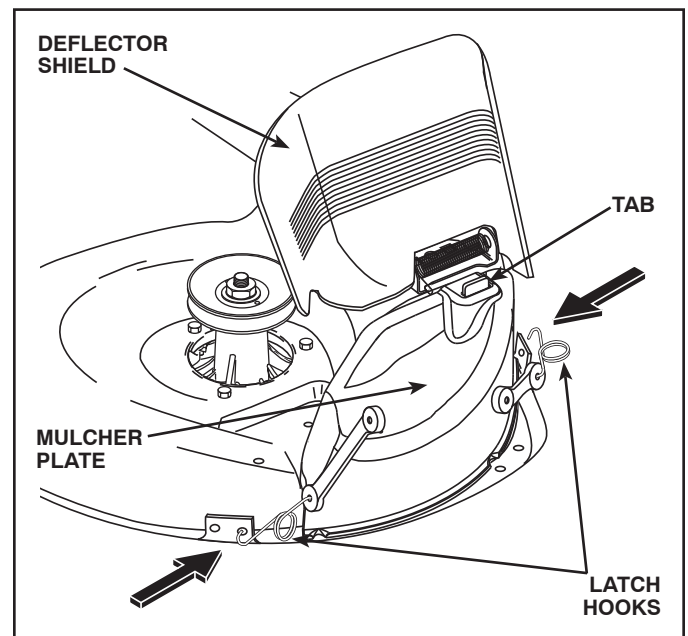

FIG. 5

---

# ASSEMBLY

---

## **TO ROLL TRACTOR OFF SKID (See Operation section for location and function of controls)**

- Raise attachment lift lever to its highest position.
- Release parking brake by depressing clutch/brake pedal.
- Place freewheel control in "transmission disengaged position" (See "TO TRANSPORT" in the Operation section of this manual).
- Roll tractor forward off skid.
- Remove banding holding the deflector shield up against tractor.

Continue with the instructions that follow.

## **CHECK TIRE PRESSURE**

The tires on your tractor were overinflated at the factory for shipping purposes. Correct tire pressure is important for best cutting performance.

- Reduce tire pressure to PSI shown on tires.

## **CHECK DECK LEVELNESS**

For best cutting results, mower housing should be properly leveled. See "TO LEVEL MOWER HOUSING" in the Service and Adjustments section of this manual.

## **CHECK FOR PROPER POSITION OF BELTS**

See the figures that are shown for replacing motion and mower blade drive belts in the Service and Adjustments section of this manual. Verify that the belts are routed correctly.

## **CHECK BRAKE SYSTEM**

After you learn how to operate your tractor, check to see that the brake is operating properly. See "TO CHECK BRAKE" in the Service and Adjustments section of this manual.

## **✓ CHECKLIST**

*BEFORE YOU OPERATE YOUR NEW TRACTOR, WE WISH TO ASSURE THAT YOU RECEIVE THE BEST PERFORMANCE AND SATISFACTION FROM THIS QUALITY PRODUCT.*

*PLEASE REVIEW THE FOLLOWING CHECKLIST:*

- ✓ All assembly instructions have been completed.
- ✓ No remaining loose parts in carton.
- ✓ Battery is properly prepared and charged.
- ✓ Seat is adjusted comfortably and tightened securely.
- ✓ All tires are properly inflated. (For shipping purposes, the tires were overinflated at the factory).
- ✓ Be sure mower deck is properly leveled side-to-side/front-to-rear for best cutting results. (Tires must be properly inflated for leveling).
- ✓ Check mower and drive belts. Be sure they are routed properly around pulleys and inside all belt keepers.
- ✓ Check wiring. See that all connections are still secure and wires are properly clamped.
- ✓ Before driving tractor, be sure freewheel control is in "transmission engaged" position (see "TO TRANSPORT" in the Operation section of this manual).

*WHILE LEARNING HOW TO USE YOUR TRACTOR, PAY EXTRA ATTENTION TO THE FOLLOWING IMPORTANT ITEMS:*

- ✓ Engine oil is at proper level.
- ✓ Fuel tank is filled with fresh, clean, regular unleaded gasoline.
- ✓ Become familiar with all controls, their location and function. Operate them before you start the engine.
- ✓ Be sure brake system is in safe operating condition.
- ✓ Be sure Operator Presence System and Reverse Operation System (ROS) are working properly (See the Operation and Maintenance sections in this manual).
- ✓ It is important to purge the transmission before operating your tractor for the first time. Follow proper starting and transmission purging instructions (See "TO START ENGINE" and "PURGE TRANSMISSION" in the Operation section of this manual).



# OPERATION

These symbols may appear on your tractor or in literature supplied with the product. Learn and understand their meaning.

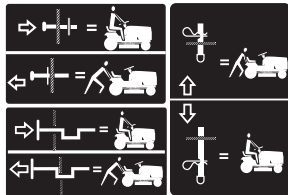

**FREE WHEEL**  
(Automatic Models only)



Failure to follow instructions could result in serious injury or death. The safety alert symbol is used to identify safety information about hazards which can result in death, serious injury and/or property damage.



**DANGER** indicates a hazard which, if not avoided, will result in death or serious injury.



**WARNING** indicates a hazard which, if not avoided, could result in death or serious injury.



**CAUTION** indicates a hazard which, if not avoided, might result in minor or moderate injury.

**CAUTION** when used **without** the alert symbol, indicates a situation that **could result in damage to the tractor and/or engine.**



**HOT SURFACES** indicates a hazard which, if not avoided, could result in death, serious injury and/or property damage.



**FIRE** indicates a hazard which, if not avoided, could result in death, serious injury and/or property damage.

# OPERATION

## KNOW YOUR TRACTOR

### READ THIS OWNER'S MANUAL AND SAFETY RULES BEFORE OPERATING YOUR TRACTOR

Compare the illustrations with your tractor to familiarize yourself with the locations of various controls and adjustments. Save this manual for future reference.

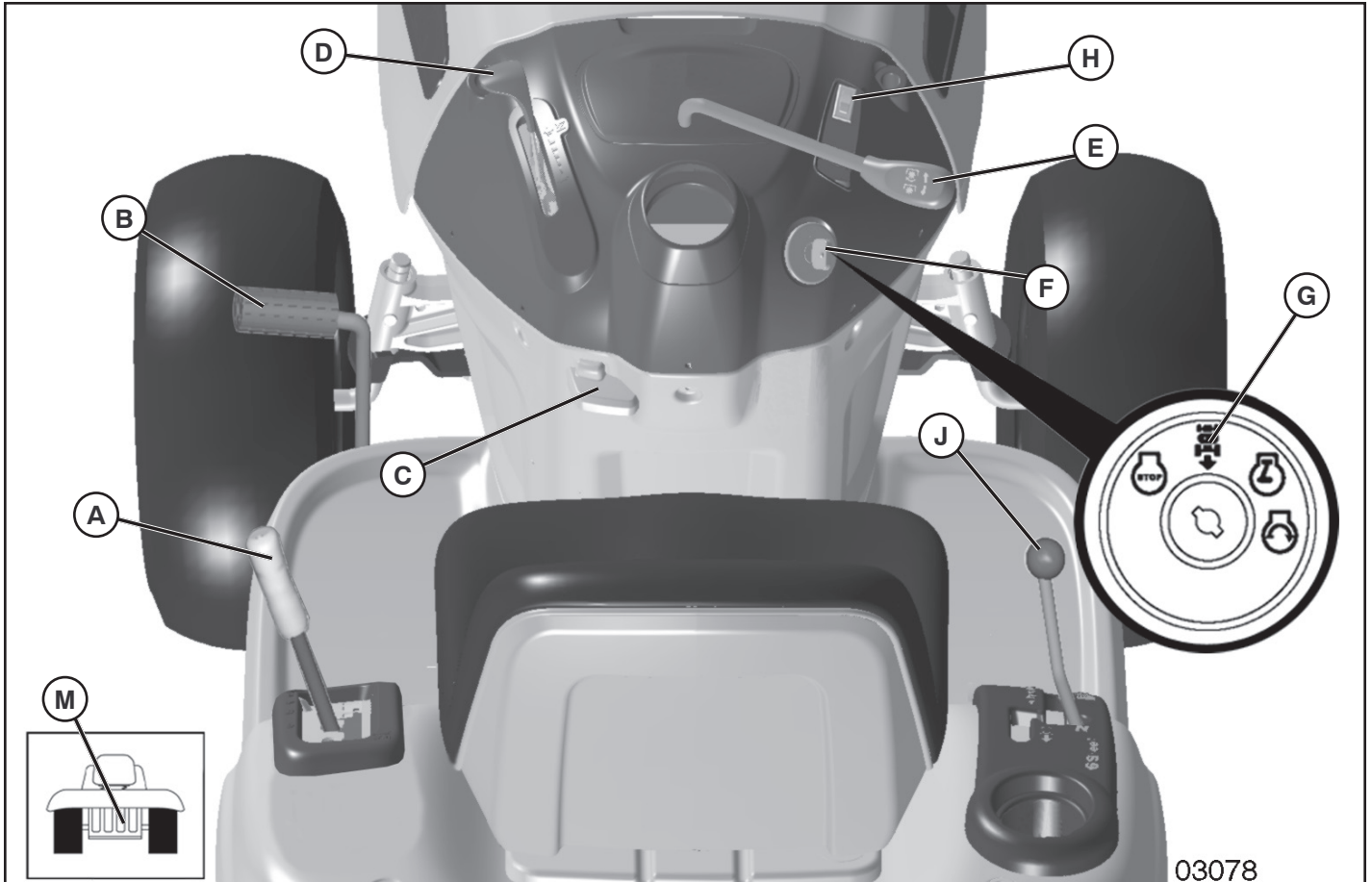

Fig. 6

Our tractors conform to the applicable safety standards of the American National Standards Institute.

**(A) ATTACHMENT LIFT LEVER** - Used to raise and lower the mower or other attachments mounted to your tractor.

**(B) CLUTCH/BRAKE PEDAL** - Used for braking the tractor and starting the engine.

**(C) PARKING BRAKE** - Locks clutch/brake pedal into the brake position.

**(D) THROTTLE CONTROL** - Used to control engine speed.

**(E) ATTACHMENT CLUTCH LEVER** - Used to engage the mower blades, or other attachments mounted to your tractor.

**(F) IGNITION SWITCH** - Used for starting and stopping the engine.

**(G) REVERSE OPERATION SYSTEM (ROS) "ON" POSITION** - Allows operation of mower or other powered attachment while in reverse.

**(H) LIGHT SWITCH** - Turns the headlights on and off.

**(J) MOTION CONTROL LEVER** - Selects the speed and direction of tractor.

**(M) FREEWHEEL CONTROL** - Disengages transmission for pushing or slowly towing the tractor with the engine off.

# OPERATION



The operation of any tractor can result in foreign objects thrown into the eyes, which can result in severe eye damage. Always wear safety glasses or eye shields while operating your tractor or performing any adjustments or repairs. We recommend standard safety glasses or a wide vision safety mask worn over spectacles.

## HOW TO USE YOUR TRACTOR

### TO SET PARKING BRAKE (See Fig. 7)

Your tractor is equipped with an operator presence sensing switch. When engine is running, any attempt by the operator to leave the seat without first setting the parking brake will shut off the engine.

1. Depress clutch/brake pedal (B) all the way down and hold.
2. Pull parking brake lever (C) up and hold, release pressure from clutch/brake pedal (B), then release parking brake lever. Pedal should remain in brake position. Make sure parking brake will hold tractor secure.

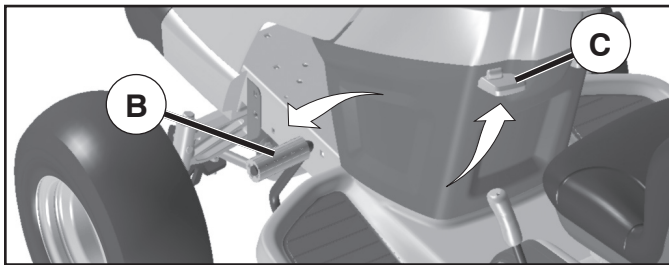
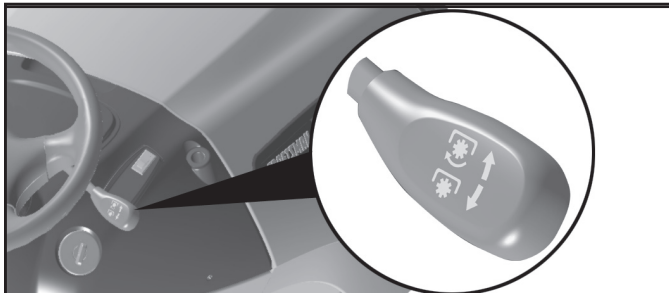

Fig. 7

### STOPPING (See Fig. 8)

#### MOWER BLADES -

- To stop mower blades, place attachment clutch control in the "DISENGAGED" position (☒).



(☒) ATTACHMENT CLUTCH LEVER "DISENGAGED"

(☑) ATTACHMENT CLUTCH LEVER "ENGAGED"

Fig. 8

#### GROUND DRIVE -

- To stop ground drive, depress brake pedal all the way down.
- Move motion control lever (J) to neutral position.

#### ENGINE -

- Move throttle control (D) between half and full speed (fast) position.

**NOTE:** Failure to move throttle control between half and full speed (fast) position, before stopping, may cause engine to "backfire".

- Turn ignition key (F) to "STOP" position and remove key. Always remove key when leaving tractor to prevent unauthorized use.

- Never use the choke to stop the engine.

**IMPORTANT:** LEAVING THE IGNITION SWITCH IN ANY POSITION OTHER THAN "STOP" WILL CAUSE THE BATTERY TO DISCHARGE AND GO DEAD.

**NOTE:** Under certain conditions when tractor is standing idle with the engine running, hot engine exhaust gases may cause "browning" of grass. To eliminate this possibility, always stop engine when stopping tractor on grass areas.



**CAUTION:** Always stop tractor completely, as described above, and set parking brake before leaving the operator's position.

### TO USE THROTTLE CONTROL (D) (See Fig. 9)

Always operate engine at full speed (fast).

- Operating engine at less than full speed (fast) reduces the engine's operating efficiency.
- Full speed (fast) offers the best mower performance.

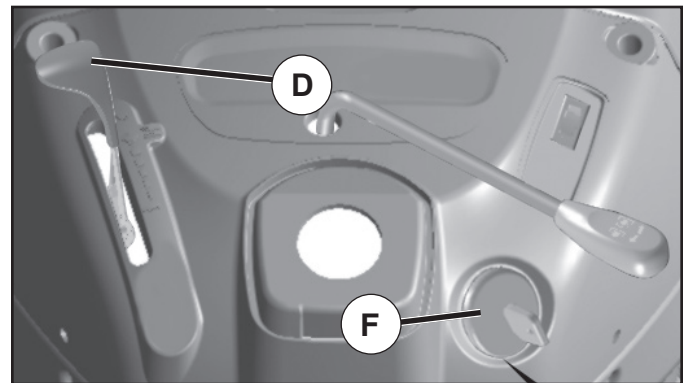

Fig. 9

### TO MOVE FORWARD AND BACKWARD (See Fig. 10)

The direction and speed of movement is controlled by the motion control lever. (J)

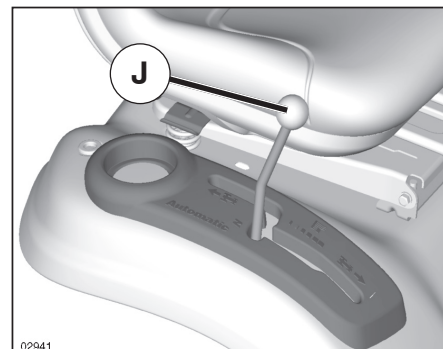

Fig. 10

- Start tractor with motion control lever in neutral position.
- Release parking brake.
- Slowly move motion control lever to desired position.

# OPERATION

## TO ADJUST MOWER CUTTING HEIGHT (See Fig. 11)

The position of the attachment lift lever (A) determines the cutting height.

- Put attachment lift lever in desired cutting height slot.

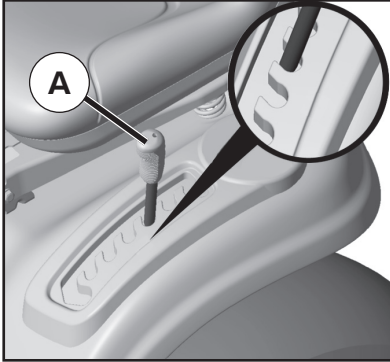

Fig. 11

The cutting height range is approximately 1" to 4". The heights are measured from the ground to the blade tip with the engine not running. These heights are approximate and may vary depending upon soil conditions, height of grass and types of grass being mowed.

- The average lawn should be cut to approximately 2-1/2" during the cool season and to over 3" during hot months. For healthier and better looking lawns, mow often and after moderate growth.
- For best cutting performance, grass over 6" in height should be mowed twice. Make the first cut relatively high; the second to desired height.

## TO ADJUST GAUGE WHEELS (See Fig. 12)

Gauge wheels are properly adjusted when they are slightly off the ground when mower is at the desired cutting height in operating position. Gauge wheels then keep the deck in proper position to help prevent scalping in most terrain conditions.

**NOTE:** Adjust gauge wheels with tractor on a flat level surface.

- Adjust mower to desired cutting height (See "TO ADJUST MOWER CUTTING HEIGHT" in this section of manual).
- With mower in desired height of cut position, gauge wheels should be assembled so they are slightly off the ground. Install gauge wheel in appropriate hole. Tighten securely.
- Repeat for all, installing gauge wheel in same adjustment hole.

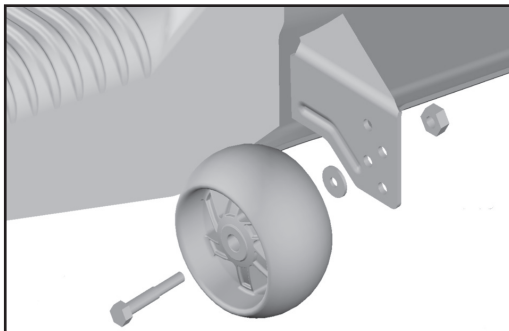

Fig. 12

## TO OPERATE MOWER

Your tractor is equipped with an operator presence sensing switch. Any attempt by the operator to leave the seat with the engine running and the attachment clutch engaged will shut off the engine. You must remain fully and centrally positioned in the seat to prevent the engine from hesitating or cutting off when operating your equipment on rough, rolling terrain or hills.

- Select desired height of cut (see "TO ADJUST MOWER CUTTING HEIGHT")
- Start mower blades by engaging attachment clutch control.

## TO STOP MOWER BLADES

- Disengage attachment clutch control.



**CAUTION:** Do not operate the mower without either the entire grass catcher, on mowers so equipped, or the deflector shield (S) in place (See Fig. 13).

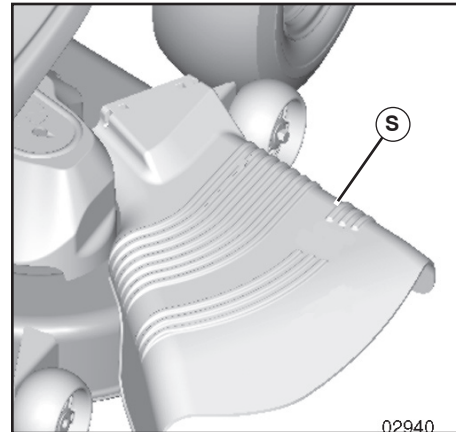

Fig. 13

## TO OPERATE ON HILLS



**CAUTION:** Do not drive up or down hills with slopes greater than 15° and do not drive across any slope.

- Choose the slowest speed before starting up or down hills.
- Avoid stopping or changing speed on hills.
- If stopping is absolutely necessary, push clutch/brake pedal quickly to brake position and engage parking brake.
- Move motion control lever to neutral position.

**IMPORTANT:** THE MOTION CONTROL LEVER DOES NOT RETURN TO NEUTRAL POSITION WHEN THE CLUTCH/BRAKE PEDAL IS DEPRESSED.

- To restart movement, slowly release parking brake and clutch/brake pedal.
- Slowly move motion control lever to slowest setting.
- Make all turns slowly.

# OPERATION

## REVERSE OPERATION SYSTEM (ROS)

Your tractor is equipped with a Reverse Operation System (ROS). Any attempt by the operator to travel in the reverse direction with the attachment clutch engaged will shut off the engine unless ignition key is placed in the ROS "ON" position.

**⚠WARNING:** Backing up with the attachment clutch engaged while mowing is strongly discouraged. Turning the ROS "ON", to allow reverse operation with the attachment clutch engaged, should only be done when the operator decides it is necessary to reposition the machine with the attachment engaged. Do not mow in reverse unless absolutely necessary.

USING THE REVERSE OPERATION SYSTEM (See Fig. 14)

Only use if you are certain no children or other bystanders will enter the mowing area.

- Move motion control lever to neutral position.
- With engine running, turn ignition key counterclockwise to ROS "ON" position.
- Look down and behind before and while backing.
- Slowly move motion control lever to reverse (R) position to start movement.
- When use of the ROS is no longer needed, turn the ignition key clockwise to engine "ON" position.

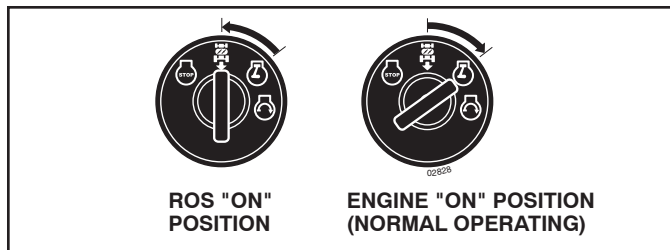

Fig. 14

## TO TRANSPORT (See Figs. 6 and 15)

When pushing or towing your tractor, be sure to disengage transmission by placing freewheel control in freewheeling position. Free wheel control is located at the rear of the tractor.

- Raise attachment lift to highest position with attachment lift control.
- Pull freewheel control out and down into the slot and release so it is held in the disengaged position.
- Do not push or tow tractor at more than two (2) MPH.
- To reengage transmission, reverse above procedure.

**NOTE:** To protect hood from damage when transporting your tractor on a truck or a trailer, be sure hood is closed and secured to tractor. Use an appropriate means of tying hood to tractor (rope, cord, etc.).

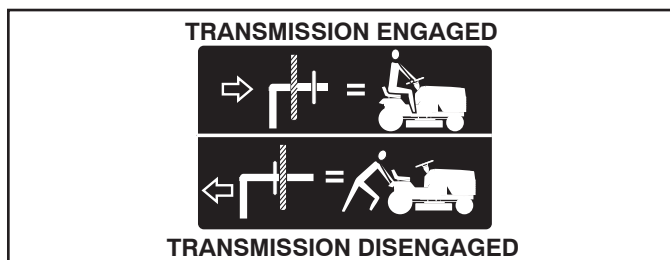

Fig. 15

## TOWING CARTS AND OTHER ATTACHMENTS

Tow only the attachments that are recommended by and comply with specifications of the manufacturer of your tractor. Use common sense when towing. Too heavy of a load, while on a slope, is dangerous. Tires can lose traction with the ground and cause you to lose control of your tractor.

## BEFORE STARTING THE ENGINE

### CHECK ENGINE OIL LEVEL

The engine in your tractor has been shipped, from the factory, already filled with summer weight oil.

- Check engine oil with tractor on level ground.
- Remove oil fill cap/dipstick and wipe clean, reinsert the dipstick and screw cap tight, wait for a few seconds, remove and read oil level. If necessary, add oil until "FULL" mark on dipstick is reached. Do not overfill.
- For cold weather operation you should change oil for easier starting (See "OIL VISCOSITY CHART" in the Maintenance section of this manual).
- To change engine oil, see the Maintenance section in this manual.

### ADD GASOLINE

- Fill fuel tank to bottom of filler neck. Do not overfill. Use fresh, clean, regular unleaded gasoline with a minimum of 87 octane. (Use of leaded gasoline will increase carbon and lead oxide deposits and reduce valve life). Do not mix oil with gasoline. Purchase fuel in quantities that can be used within 30 days to assure fuel freshness.



**CAUTION:** Wipe off any spilled oil or fuel. Do not store, spill or use gasoline near an open flame.

**IMPORTANT:** WHEN OPERATING IN TEMPERATURES BELOW 32°F(0°C), USE FRESH, CLEAN WINTER GRADE GASOLINE TO HELP ENSURE GOOD COLD WEATHER STARTING.

**CAUTION:** Alcohol blended fuels (called gasohol or using ethanol or methanol) can attract moisture which leads to separation and formation of acids during storage. Acidic gas can damage the fuel system of an engine while in storage. To avoid engine problems, the fuel system should be emptied before storage of 30 days or longer. Drain the gas tank, start the engine and let it run until the fuel lines and carburetor are empty. Use fresh fuel next season. See Storage Instructions for additional information. Never use engine or carburetor cleaner products in the fuel tank or permanent damage may occur.

# OPERATION

## TO START ENGINE (See Fig. 6)

When starting the engine for the first time or if the engine has run out of fuel, it will take extra cranking time to move fuel from the tank to the engine.

- Be sure freewheel control is in the transmission engaged position.
- Sit on seat in operating position, depress clutch/brake pedal and set parking brake.
- Place motion control lever in neutral position.
- Move attachment clutch to "DISENGAGED" position.
- Move throttle control to choke position.

**NOTE:** Before starting, read the warm and cold starting procedures below.

- Insert key into ignition and turn key clockwise to "START" position and release key as soon as engine starts. Do not run starter continuously for more than fifteen seconds per minute. If the engine does not start after several attempts, move throttle control to fast position, wait a few minutes and try again. If engine still does not start, move the throttle control back to the choke position and retry.

### WARM WEATHER STARTING (50°F (10°C) and above)

- When engine starts, move the throttle control to the fast position.
- The attachments and ground drive can now be used. If the engine does not accept the load, restart the engine and allow it to warm up for one minute using the choke as described above.

### COLD WEATHER STARTING (50°F (10°C) and below)

- When engine starts, allow engine to run with the throttle control in the choke position until the engine runs roughly, then move throttle control to fast position. This may require an engine warm-up period from several seconds to several minutes, depending on the temperature.

### AUTOMATIC TRANSMISSION WARM UP

- Before driving the unit in cold weather, the transmission should be warmed up as follows:
  - Be sure the tractor is on level ground.
  - Place the motion control lever in neutral. Release the parking brake and let the clutch/brake slowly return to operating position.
  - Allow one minute for transmission to warm up. This can be done during the engine warm up period.
- The attachments can also be used during the engine warm-up period after the transmission has been warmed up.

**NOTE:** If at a high altitude (above 3000 feet) or in cold temperatures (below 32° F/0°C) the carburetor fuel mixture may need to be adjusted for best engine performance. See "TO ADJUST CARBURETOR" in the Service and Adjustments section of this manual.

## PURGE TRANSMISSION



**CAUTION:** Never engage or disengage freewheel lever while the engine is running.

To ensure proper operation and performance, it is recommended that the transmission be purged before operating tractor for the first time. This procedure will remove any trapped air inside the transmission which may have developed during shipping of your tractor.

**IMPORTANT:** SHOULD YOUR TRANSMISSION REQUIRE REMOVAL FOR SERVICE OR REPLACEMENT, IT SHOULD BE PURGED AFTER REINSTALLATION BEFORE OPERATING THE TRACTOR.

1. Place tractor safely on a level surface - that is clear and open - with engine off and parking brake set.
2. Disengage transmission by placing freewheel control in freewheeling position (See "TO TRANSPORT" in this section of manual).
3. Sitting in the tractor seat, start engine. After the engine is running, move throttle control to slow position. With motion control lever in neutral position, slowly disengage clutch/brake pedal.



**CAUTION:** At any time, during step 4, there may be movement of the drive wheels.

4. Move motion control lever to full forward position and hold for five (5) seconds. Move lever to full reverse position and hold for five (5) seconds. Repeat this procedure three (3) times.
5. Move motion control lever to neutral position. Shut-off engine and set parking brake.
6. Engage transmission by placing freewheel control in engaged position (See "TO TRANSPORT" in this section of manual).
7. Sitting in the tractor seat, start engine. After the engine is running, move throttle control to half (1/2) speed. With motion control lever in neutral position, slowly disengage clutch/brake pedal.
8. Slowly move motion control lever forward, after the tractor moves approximately five (5) feet, slowly move motion control lever to reverse position. After the tractor moves approximately five (5) feet return the motion control lever to the neutral position. Repeat this procedure with the motion control lever three (3) times.

Your transmission is now purged and now ready for normal operation.

# OPERATION

## MOWING TIPS

- Tire chains cannot be used when the mower housing is attached to tractor.
- Mower should be properly leveled for best mowing performance. See "TO LEVEL MOWER HOUSING" in the Service and Adjustments section of this manual.
- The left hand side of mower should be used for trimming.
- Drive so that clippings are discharged onto the area that has been cut. Have the cut area to the right of the tractor. This will result in a more even distribution of clippings and more uniform cutting.
- When mowing large areas, start by turning to the right so that clippings will discharge away from shrubs, fences, driveways, etc. After one or two rounds, mow in the opposite direction making left hand turns until finished (See Fig. 16).

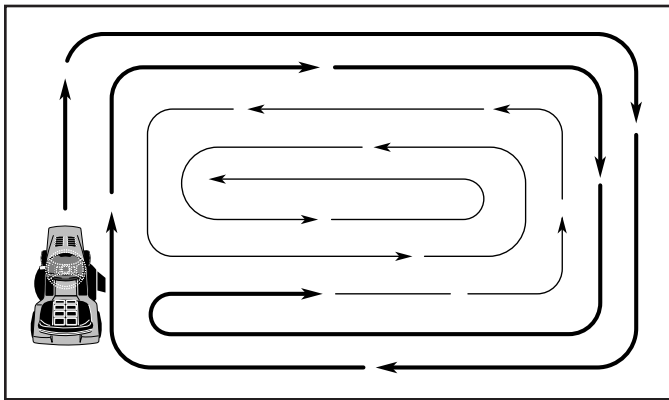

Fig. 16

- If grass is extremely tall, it should be mowed twice to reduce load and possible fire hazard from dried clippings. Make first cut relatively high; the second to the desired height.
- Do not mow grass when it is wet. Wet grass will plug mower and leave undesirable clumps. Allow grass to dry before mowing.
- **Always operate engine at full throttle when mowing** to assure better mowing performance and proper discharge of material. Regulate ground speed by selecting a low enough gear to give the mower cutting performance as well as the quality of cut desired.
- When operating attachments, select a ground speed that will suit the terrain and give best performance of the attachment being used.

## MULCHING MOWING TIPS

**IMPORTANT:** FOR BEST PERFORMANCE, KEEP MOWER HOUSING FREE OF BUILT-UP GRASS AND TRASH. CLEAN AFTER EACH USE.

- The special mulching blade will recut the grass clippings many times and reduce them in size so that as they fall onto the lawn they will disperse into the grass and not be noticed. Also, the mulched grass will biodegrade quickly to provide nutrients for the lawn. Always mulch with your highest engine (blade) speed as this will provide the best recutting action of the blades.
- Avoid cutting your lawn when it is wet. Wet grass tends to form clumps and interferes with the mulching action. The best time to mow your lawn is the early afternoon. At this time the grass has dried, yet the newly cut area will not be exposed to direct sunlight.
- For best results, adjust the mower cutting height so that the mower cuts off only the top one-third of the grass blades (See Fig. 17). For extremely heavy mulching, reduce your width of cut on each pass and mow slowly.

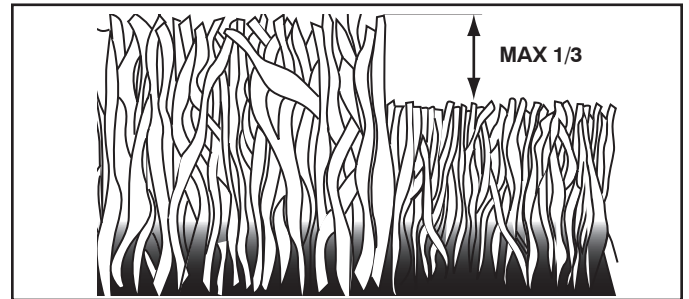

Fig. 17

- Certain types of grass and grass conditions may require that an area be mulched a second time to completely hide the clippings. When doing a second cut, mow across (perpendicular) to the first cut path.
- Change your cutting pattern from week to week. Mow north to south one week then change to east to west the next week. This will help prevent matting and graining of the lawn.

# MAINTENANCE

MAINTENANCE SCHEDULE		BEFORE EACH USE	EVERY 8 HOURS	EVERY 25 HOURS	EVERY 50 HOURS	EVERY 100 HOURS	EVERY SEASON	BEFORE STORAGE
TRACTOR	Check Brake Operation	✓	✓					
	Check Tire Pressure	✓	✓					
	Check Operator Presence & ROS Systems	✓						
	Check for Loose Fasteners	✓				✓		✓
	Check/Replace Mower Blades			✓ <sub>3</sub>				
	Lubrication Chart			✓				✓
	Check Battery Level			✓ <sub>4</sub>				
	Clean Battery and Terminals			✓				✓
	Clean Debris Off Steering Plate			✓ <sub>5</sub>				
	Check Transaxle Cooling			✓				
	Check Mower Levelness				✓			
	Check V-Belts					✓		
ENGINE	Check Engine Oil Level	✓	✓					✓
	Change Engine Oil (with oil filter)				✓ <sub>1,2</sub>			✓
	Change Engine Oil (without oil filter)			✓ <sub>1,2</sub>				✓
	Clean Air Filter			✓ <sub>2</sub>				
	Clean Air Screen			✓ <sub>2</sub>				
	Inspect Muffler/Spark Arrester				✓			
	Replace Oil Filter (If equipped)					✓ <sub>1,2</sub>		
	Clean Engine Cooling Fins					✓ <sub>2</sub>		
	Replace Spark Plug					✓	✓	
	Replace Air Filter Paper Cartridge					✓ <sub>2</sub>		
	Replace Fuel Filter						✓	

1 - Change more often when operating under a heavy load or in high ambient temperatures.  
2 - Service more often when operating in dirty or dusty conditions.

3 - Replace blades more often when mowing in sandy soil.  
4 - Not required if equipped with maintenance-free battery.

5 - See Cleaning in Maintenance Section.

## GENERAL RECOMMENDATIONS

The warranty on this tractor does not cover items that have been subjected to operator abuse or negligence. To receive full value from the warranty, operator must maintain tractor as instructed in this manual.

Some adjustments will need to be made periodically to properly maintain your tractor.

At least once a season, check to see if you should make any of the adjustments described in the Service and Adjustments section of this manual.

- At least once a year you should replace the spark plug, clean or replace air filter, and check blades and belts for wear. A new spark plug and clean air filter assure proper air-fuel mixture and help your engine run better and last longer.

## BEFORE EACH USE

- Check engine oil level.
- Check brake operation.
- Check tire pressure.
- Check operator presence and ROS systems for proper operation.
- Check for loose fasteners.

## LUBRICATION CHART

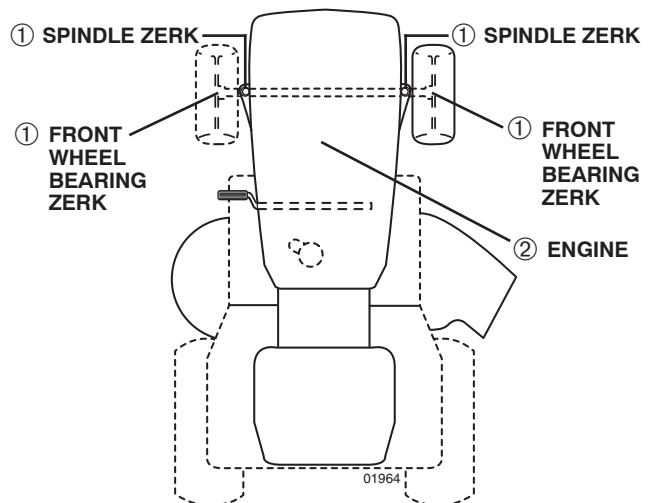

- ① General Purpose Grease
- ② Refer to Maintenance "ENGINE" Section

**IMPORTANT:** DO NOT OIL OR GREASE THE PIVOT POINTS WHICH HAVE SPECIAL NYLON BEARINGS. VISCOUS LUBRICANTS WILL ATTRACT DUST AND DIRT THAT WILL SHORTEN THE LIFE OF THE SELF-LUBRICATING BEARINGS. IF YOU FEEL THEY MUST BE LUBRICATED, USE ONLY A DRY, POWDERED GRAPHITE TYPE LUBRICANT SPARINGLY.



# MAINTENANCE

## TRACTOR

Always observe safety rules when performing any maintenance.

### BRAKE OPERATION

If tractor requires more than five (5) feet to stop at highest speed in highest gear on a level, dry concrete or paved surface, then brake must be checked and adjusted. (See "TO CHECK BRAKE" in the Service and Adjustments section of this manual).

### TIRES

- Maintain proper air pressure in all tires (See the sides of tires for proper PSI).
- Keep tires free of gasoline, oil, or insect control chemicals which can harm rubber.
- Avoid stumps, stones, deep ruts, sharp objects and other hazards that may cause tire damage.

**NOTE:** To seal tire punctures and prevent flat tires due to slow leaks, tire sealant may be purchased from your local parts dealer. Tire sealant also prevents tire dry rot and corrosion.

### OPERATOR PRESENCE SYSTEM AND REVERSE OPERATION SYSTEM (ROS) (See Fig. 18)

Be sure operator presence and reverse operation systems are working properly. If your tractor does not function as described, repair the problem immediately.

- The engine should not start unless the brake pedal is fully depressed, and the attachment clutch control is in the disengaged position.

### CHECK OPERATOR PRESENCE SYSTEM

- When the engine is running, any attempt by the operator to leave the seat without first setting the parking brake should shut off the engine.
- When the engine is running and the attachment clutch is engaged, any attempt by the operator to leave the seat should shut off the engine.
- The attachment clutch should never operate unless the operator is in the seat.

### CHECK REVERSE OPERATION (ROS) SYSTEM

- When the engine is running with the ignition switch in the engine "ON" position and the attachment clutch engaged, any attempt by the operator to shift into reverse should shut off the engine.
- When the engine is running with the ignition switch in the ROS "ON" position and the attachment clutch engaged, any attempt by the operator to shift into reverse should NOT shut off the engine.

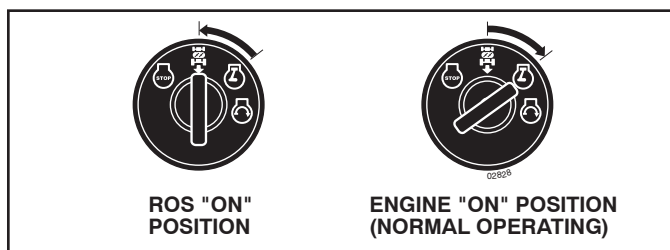

Fig. 18

## BLADE CARE

For best results mower blades must be kept sharp. Replace bent or damaged blades.



**CAUTION:** Use only a replacement blade approved by the manufacturer of your tractor. Using a blade not approved by the manufacturer of your tractor is hazardous, could damage your tractor and void your warranty.

### BLADE REMOVAL (See Fig. 19)

- Raise mower to highest position to allow access to blades.

**NOTE:** Protect your hands with gloves and/or wrap blade with heavy cloth.

- Remove blade bolt by turning counterclockwise.
- Install new or resharpened blade with stamped "THIS SIDE UP" facing deck and mandrel assembly.

**IMPORTANT:** TO ENSURE PROPER ASSEMBLY, CENTER HOLE IN BLADE MUST ALIGN WITH STAR ON MANDREL ASSEMBLY.

- Install and tighten blade bolt securely (45-55 Ft. Lbs. torque).

**IMPORTANT:** SPECIAL BLADE BOLT HEAT TREATED.

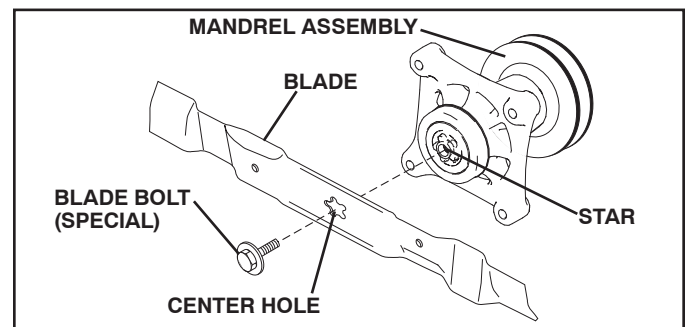

Fig. 19

## BATTERY

Your tractor has a battery charging system which is sufficient for normal use. However, periodic charging of the battery with an automotive charger will extend its life.

- Keep battery and terminals clean.
- Keep battery bolts tight.
- Keep small vent holes open.
- Recharge at 6-10 amperes for 1 hour.

**NOTE:** The original equipment battery on your tractor is maintenance free. Do not attempt to open or remove caps or covers. Adding or checking level of electrolyte is not necessary.

### TO CLEAN BATTERY AND TERMINALS

Corrosion and dirt on the battery and terminals can cause the battery to "leak" power.

- Raise hood.
- Disconnect BLACK battery cable first then RED battery cable and remove battery from tractor.
- Rinse the battery with plain water and dry.
- Clean terminals and battery cable ends with wire brush until bright.
- Coat terminals with grease or petroleum jelly.
- Reinstall battery (See "REPLACING BATTERY" in the SERVICE AND ADJUSTMENTS section of this manual).

# MAINTENANCE

## V-BELTS

Check V-belts for deterioration and wear after 100 hours of operation and replace if necessary. The belts are not adjustable. Replace belts if they begin to slip from wear.

## TRANSAXLE MAINTENANCE

The transmission fan and cooling fins should be kept clean to assure proper cooling.

Do not attempt to clean fan or transmission while engine is running or while the transmission is hot. To prevent possible damage to seals, do not use high pressure water or steam to clean transmission.

- Inspect cooling fan to be sure fan blades are intact and clean.
- Inspect cooling fins for dirt, grass clippings and other materials. To prevent damage to seals, do not use compressed air or high pressure sprayer to clean cooling fins.

## TRANSAXLE PUMP FLUID

The transaxle was sealed at the factory and fluid maintenance is not required for the life of the transaxle. Should the transaxle ever leak or require servicing, contact your nearest authorized service center/department.

## ENGINE

### LUBRICATION

Only use high quality detergent oil rated with API service classification SG-SL. Select the oil's SAE viscosity grade according to your expected operating temperature. When operating in temperatures below 0° F (-18° C) synthetic oil must be used.

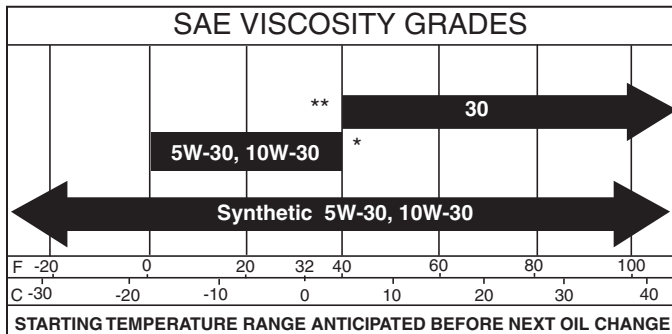

Fig. 20

**\* CAUTION:** Air cooled engines run hotter than automotive engines. The use of non-synthetic multi-viscosity oils (5W30, 10W30 etc.) in temperatures above 40° F (4° C) will result in higher than normal oil consumption. When using a multi-viscosity oil, check oil level more frequently.

**\*\* CAUTION:** SAE 30 oil, if used below 40° F (4° C), will result in hard starting and possible engine bore damage due to inadequate lubrication.



**NOTE:** Synthetic oil meeting ILSAC GF-2, API certification mark and API service symbol (shown at left) with "SJ/CF ENERGY CONSERVING" or higher, is an acceptable oil at all temperatures. **Use of synthetic oil does not alter required oil change intervals.**

Change the oil after every 50 hours of operation or at least once a year if the tractor is not used for 50 hours in one year.

Check the crankcase oil level before starting the engine and after each eight (8) hours of operation. Tighten oil fill cap/dipstick securely each time you check the oil level.

## TO CHANGE ENGINE OIL (See Fig. 21)

Determine temperature range expected before oil change. All oil must meet API service classification C.

- Be sure tractor is on level surface.
- Oil will drain more freely when warm.
- Catch oil in a suitable container.
- Remove oil fill cap/dipstick. Be careful not to allow dirt to enter the engine when changing oil.

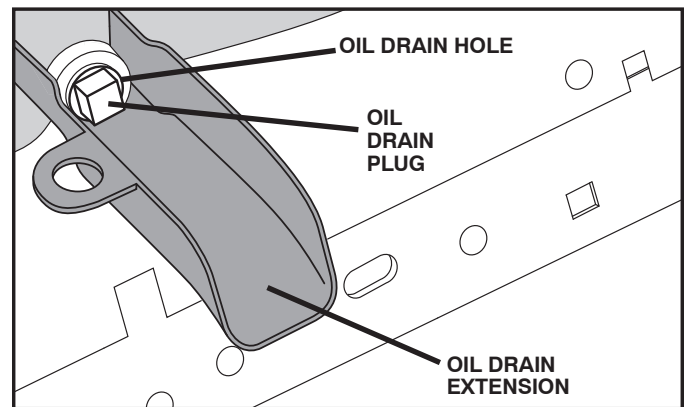

Fig. 21

- Slide oil drain extension under oil drain hole (drain hole may be flush with or protrude from engine block side wall).
- Make sure back face of oil drain extension is flush with engine side wall.
- Make sure bottom lip of oil drain extension is lined up with bottom of oil drain hole.
- Position a container to catch oil directly under front end of oil drain extension.
- Slide a 1/2" (12 point) socket mounted on an extension onto oil drain plug.
- Loosen plug while holding the oil drain extension firmly in place.
- Drain oil into container.
- After oil has drained completely, reinstall oil drain plug. (Do not tighten more than 13 Ft. Lbs.)
- Refill engine with oil through oil fill dipstick tube. Pour slowly. Do not overfill. For approximate capacity see "PRODUCT SPECIFICATIONS" section of this manual.
- Use gauge on oil fill cap/dipstick for checking level. Be sure dipstick cap is tightened securely for accurate reading. Keep oil at "FULL" line on dipstick. Tighten cap onto the tube securely when finished.

# MAINTENANCE

## ENGINE OIL FILTER

Replace the engine oil filter every season or every other oil change if the tractor is used more than 100 hours in one year. See engine manual.

## AIR FILTER

Your engine will not run properly using a dirty air filter. Service air cleaner more often under dusty conditions. See Engine Manual.

## CLEAN AIR SCREEN

Air screen must be kept free of dirt and chaff to prevent engine damage from overheating. Clean with a wire brush or compressed air to remove dirt and stubborn dried gum fibers.

## ENGINE COOLING SYSTEM

To ensure proper cooling, make sure the grass screen, cooling fins, and other external surfaces of the engine are kept clean at all times.

Every 100 hours of operation (more often under extremely dusty, dirty conditions), remove the blower housing and other cooling shrouds. Clean the cooling fins and external surfaces as necessary. Ensure the cooling shrouds are reinstalled.

**NOTE:** Operating the engine with a blocked grass screen, dirty or plugged cooling fins, and/or cooling shrouds removed will cause engine damage due to overheating.

## MUFFLER

Inspect and replace corroded muffler and spark arrester (if equipped) as it could create a fire hazard and/or damage.

## SPARK PLUGS

Replace spark plugs at the beginning of each mowing season or after every 100 hours of operation, whichever occurs first. Spark plug type and gap setting are shown in "PRODUCT SPECIFICATIONS" section of this manual.

## IN-LINE FUEL FILTER (See Fig. 22)

The fuel filter should be replaced once each season. If fuel filter becomes clogged, obstructing fuel flow to carburetor, replacement is required.

- With engine cool, remove filter and plug fuel line sections.
- Place new fuel filter in position in fuel line with arrow pointing towards carburetor.
- Be sure there are no fuel line leaks and clamps are properly positioned.
- Immediately wipe up any spilled gasoline.

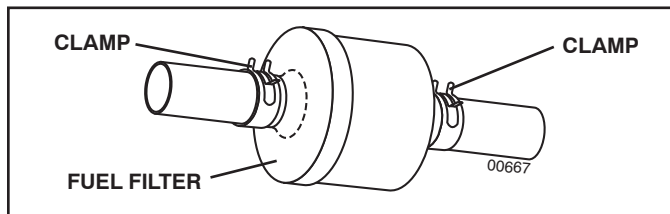

Fig. 22

## CLEANING

- Clean engine, battery, seat, finish, etc. of all foreign matter.
- Clean debris from steering plate. Debris can restrict clutch/brake pedal shaft movement, causing belt slip and loss of drive.

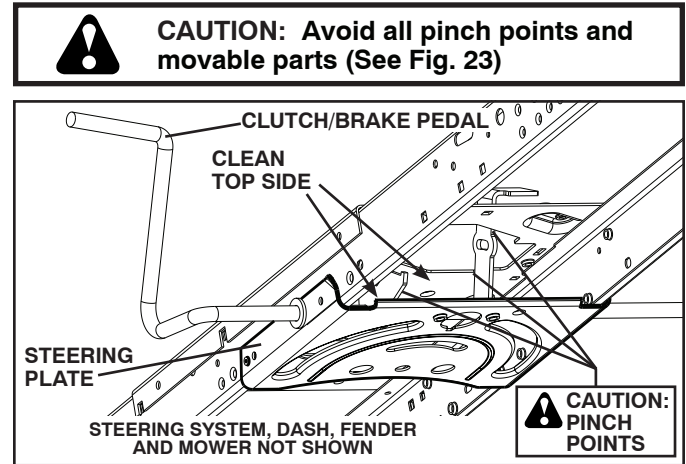

Fig. 23

- Keep finished surfaces and wheels free of all gasoline, oil, etc.
- Protect painted surfaces with automotive type wax.

We do not recommend using a garden hose or pressure washer to clean your tractor unless the engine and transmission are covered to keep water out. Water in engine or transmission will shorten the useful life of your tractor. Use compressed air or a leaf blower to remove grass, leaves and trash from tractor and mower.

# MAINTENANCE

## DECK WASHOUT PORT (See Fig. 24)

Your tractor's deck is equipped with a washout port on its surface as part of its deck wash system. It should be utilized after each use.

1. Drive the tractor to a level, clear spot on your lawn, near enough to a water spigot for your garden hose to reach.

**IMPORTANT:** Make certain the tractor's discharge chute is directed AWAY from your house, garage, parked cars, etc. Remove bagger chute or mulch cover if attached.

2. Make sure the attachment clutch control is in the "DISENGAGED" position, set the parking brake, and stop the engine.
3. Thread the nozzle adapter (packaged with your tractor's Operator's Manual) onto the end of your garden hose.
4. Pull back the lock collar of the nozzle adapter and push the adapter onto the deck washout port at the left end of the mower deck. Release the lock collar to lock the adapter on the nozzle.

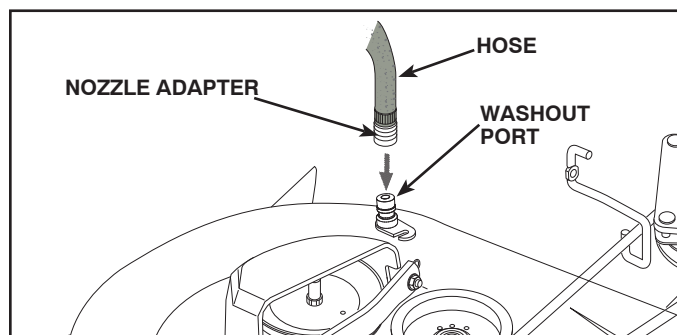

Fig. 24

**IMPORTANT:** Tug hose ensuring connection is secure.

5. Turn the water on.
6. While sitting in the operator's position on the tractor, re-start the engine and place the throttle lever in the Fast "↶" position.

**IMPORTANT:** Recheck the area making certain the area is clear.

7. Move the tractor's attachment clutch control to the "ENGAGED" position. Remain in the operator's position with the cutting deck engaged until the deck is cleaned.
8. Move the tractor's attachment clutch control to the "DISENGAGED" position. Turn the ignition key to the STOP position to turn the tractor's engine off. Turn the water off.
9. Pull back the lock collar of the nozzle adapter to disconnect the adapter from the nozzle washout port.
10. Move the tractor to a dry area, preferably a concrete or paved area. Place the attachment clutch control in the "ENGAGED" position to remove excess water and to help dry before putting the tractor away.



**WARNING: A broken or missing washout fitting could expose you or others to thrown objects from contact with the blade.**

- Replace broken or missing washout fitting immediately, prior to using mower again.
- Plug any holes in mower with bolts and locknuts.

# SERVICE AND ADJUSTMENTS



**WARNING: TO AVOID SERIOUS INJURY, BEFORE PERFORMING ANY SERVICE OR ADJUSTMENTS:**

- Depress brake pedal fully and set parking brake.
- Place motion control lever in neutral position.
- Place attachment clutch in “DISENGAGED” position.
- Turn ignition key to “STOP” and remove key.
- Make sure the blades and all moving parts have completely stopped.
- Disconnect spark plug wire from spark plug and place wire where it cannot come in contact with plug.

## TO REMOVE MOWER (See Fig. 25)

- Place attachment clutch in “DISENGAGED” position.
- Lower attachment lift lever to its lowest position.
- Roll belt off engine pulley (M) and belt keepers (G).
- Remove retainer spring (K), slide collar (L) off and push housing guide (P) out of bracket.
- Remove clutch cable spring (Q) from idler arm (R).
- Disconnect front link (E) from mower - remove retainer spring and washer.
- Go to either side of mower and disconnect mower suspension arm (A) from chassis pin (B) and rear lift link (C) from rear mower bracket (D) - remove retainer springs and washers.



**CAUTION: AFTER REAR LIFT LINKS ARE DISCONNECTED, THE ATTACHMENT LIFT LEVER WILL BE SPRING LOADED. HAVE A TIGHT GRIP ON LIFT LEVER WHEN CHANGING POSITION OF THE LEVER.**

- Slide mower out from under right side of tractor.

**IMPORTANT: IF AN ATTACHMENT OTHER THAN THE MOWER IS TO BE MOUNTED ON THE TRACTOR, REMOVE THE FRONT LINK (E) AND REAR LIFT LINKS (C) FROM TRACTOR AND HOOK THE CLUTCH SPRING (Q) INTO THE CABLE GUIDE ON FRONT EDGE OF LOWER DASH.**

## TO INSTALL MOWER (See Fig. 25-30)

Be sure tractor is on level surface and engage parking brake.

- Lower attachment lift lever to its lowest position.



**CAUTION: LIFT LEVER IS SPRING LOADED. HAVE A TIGHT GRIP ON LIFT LEVER, LOWER IT SLOWLY AND ENGAGE IN LOWEST POSITION.**

**NOTE:** Be sure mower side suspension arms (A) are pointing forward before sliding mower under tractor.

- Slide mower under tractor until it is centered under tractor.

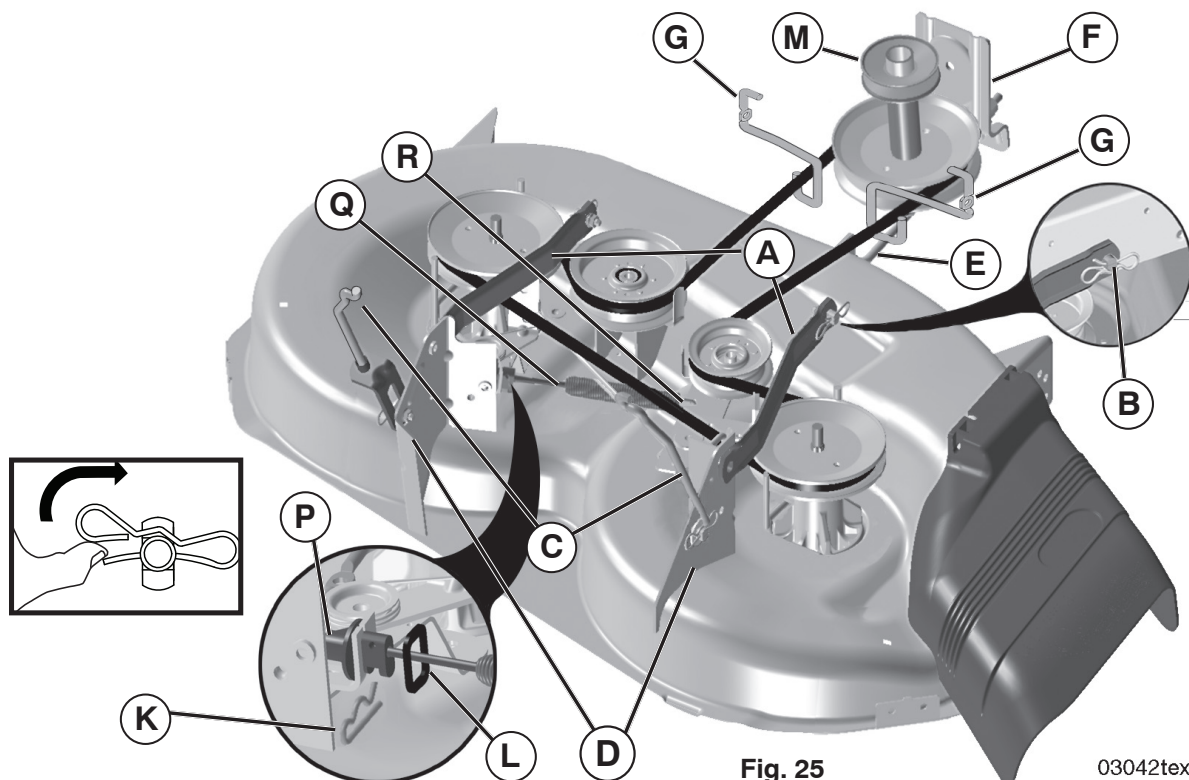

Fig. 25

03042tex

# SERVICE AND ADJUSTMENTS

- ATTACH MOWER SIDE SUSPENSION ARMS (A) TO CHASSIS - Position hole in arm over pin (B) on outside of tractor chassis and secure with retainer spring.
- Repeat on opposite side of tractor.

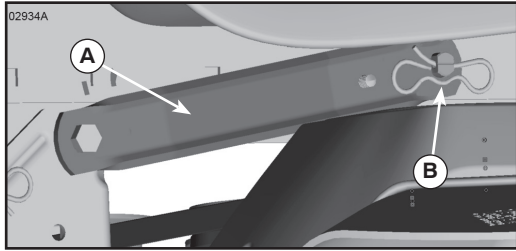

Fig. 26

- ATTACH REAR LIFT LINKS (C) - Lift rear corner of mower and position slot in link assembly over pin (D) on rear mower bracket and secure with washer and retainer spring.

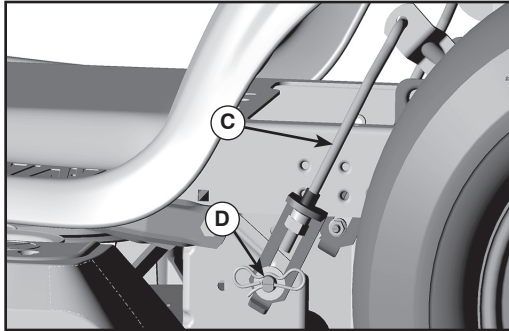

Fig. 27

- ATTACH FRONT LINK (E) - Work from left side of tractor. Insert rod end of link assembly through front hole in tractor front suspension bracket (F).

- Insert end of link (E) into hole in front mower bracket and secure with washer and retainer spring (J).

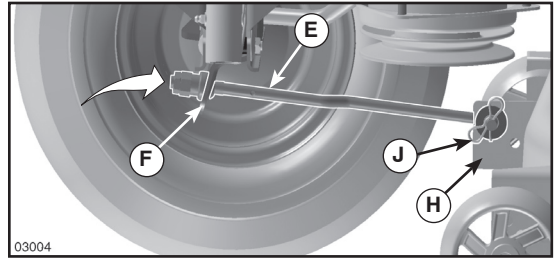

Fig. 28

- Hook end of clutch cable spring (Q) into hole in idler arm (R).
- Push clutch cable housing guide (P) into bracket, slide collar (L) onto guide and secure with retainer spring (K).
- Install belt on engine pulley (M), in belt keepers (G).

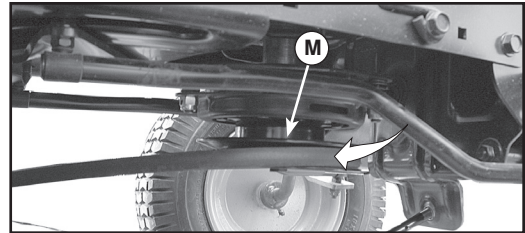

Fig. 29

**IMPORTANT:** CHECK BELT FOR PROPER ROUTING IN ALL MOWER PULLEY GROOVES.

- Raise attachment lift lever to highest position.
- If necessary, adjust gauge wheels before operating mower as shown in the Operation section of this manual.

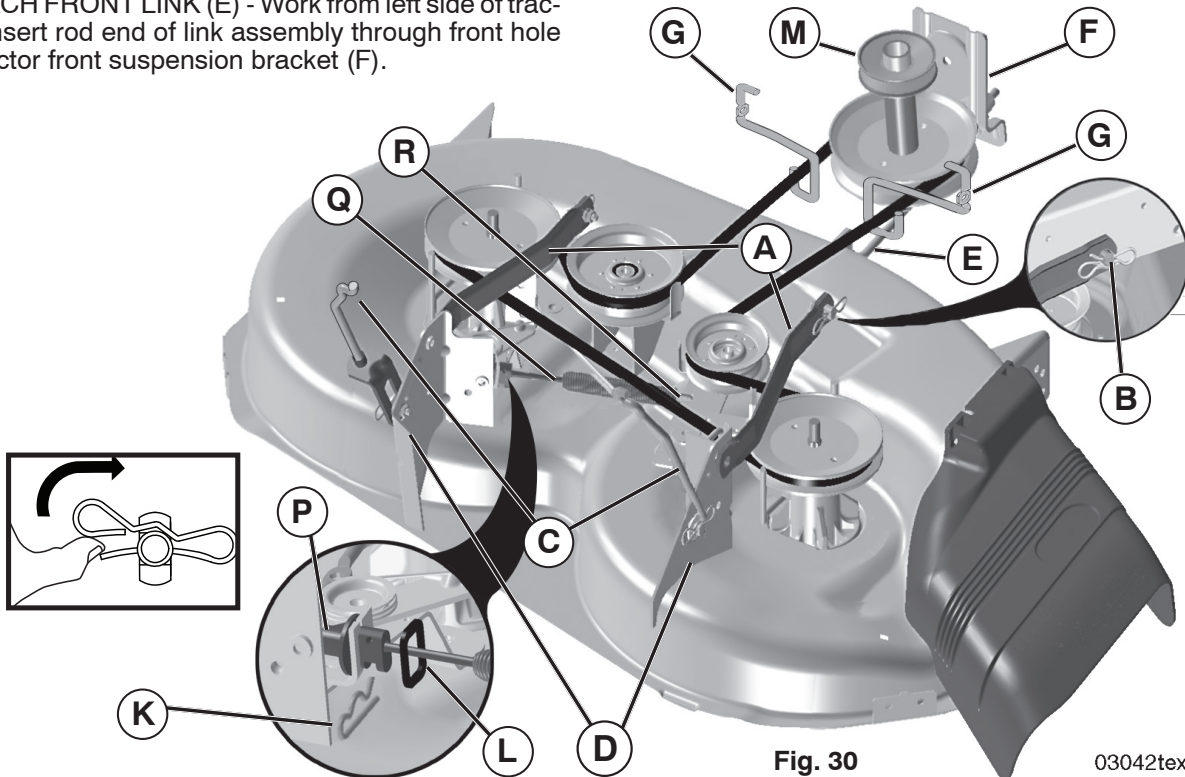

Fig. 30

03042tex

# SERVICE AND ADJUSTMENTS

## TO LEVEL MOWER

Make sure tires are properly inflated to the PSI shown on tires. If tires are over or under inflated, it may affect the appearance of your lawn and lead you to think the mower is not adjusted properly.

### VISUAL SIDE-TO-SIDE ADJUSTMENT (See Fig. 31)

- With all tires properly inflated and if your lawn appears unevenly cut, determine which side of mower is cutting lower.
- With a 3/4" or adjustable wrench, turn lift link adjustment nut (A) to the left to lower LH side of mower, or, to the right to raise LH side of mower.

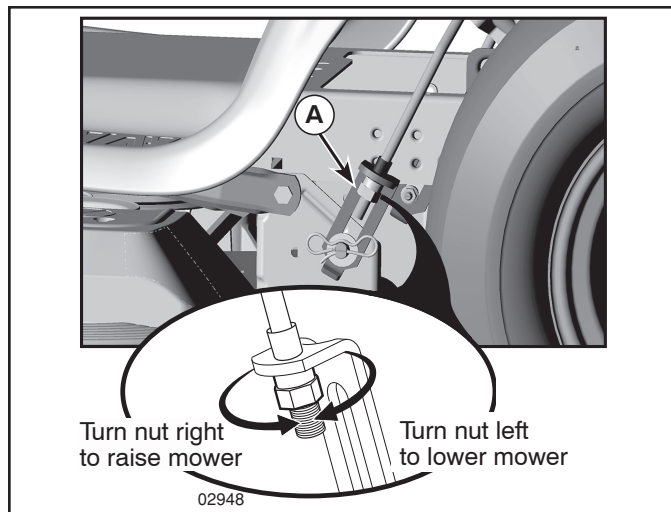

Fig. 31

**NOTE:** Each full turn of adjustment nut will change mower height about 3/16".

- Test your adjustment by mowing some uncut grass and visually checking the appearance. Readjust, if necessary, until you are satisfied with the results.

### PRECISION SIDE-TO-SIDE ADJUSTMENT (See Fig. 32)

- With all tires properly inflated, park tractor on level ground or driveway.



**CAUTION: Blades are sharp. Protect your hands with gloves and/or wrap blade with heavy cloth.**

- Raise mower to its highest position.
- At both sides of mower, position blade at side and measure the distance (A) from bottom edge of blade to the ground. The distance should be the same on both sides.

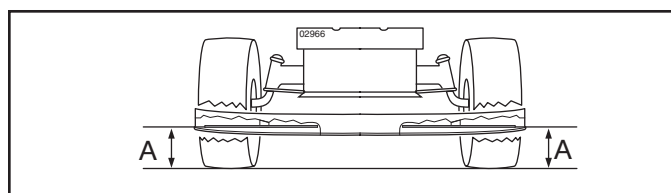

Fig. 32

- If adjustment is necessary, see step in Visual Adjustment instructions above.
- Recheck measurements, adjust if necessary until both sides are equal.

### FRONT-TO-BACK ADJUSTMENT (See Figs. 33 and 34)

**IMPORTANT:** Deck must be level side-to-side.

To obtain the best cutting results, the mower blades should be adjusted so the front tip is 1/8" to 1/2" lower than the rear tip when the mower is in its highest position.



**CAUTION: Blades are sharp. Protect your hands with gloves and/or wrap blade with heavy cloth.**

- Raise mower to highest position.
- Position blade so the tip is pointing straight forward. Measure distance (B) to the ground at front and rear tip of the blade.

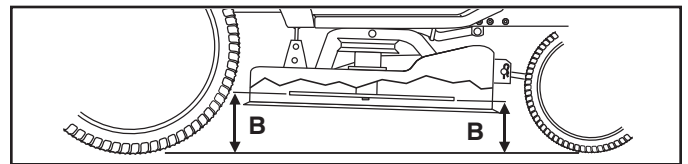

Fig. 33

- If front tip of blade is not 1/8" to 1/2" lower than the rear tip, go to the front of tractor.
- With an 11/16" or adjustable wrench, loosen jam nut A several turns to clear adjustment nut B.
- With a 3/4" or adjustable wrench, turn front link adjustment nut (B) clockwise (tighten) to raise the front of mower, or, counterclockwise (loosen) to lower the front mower.

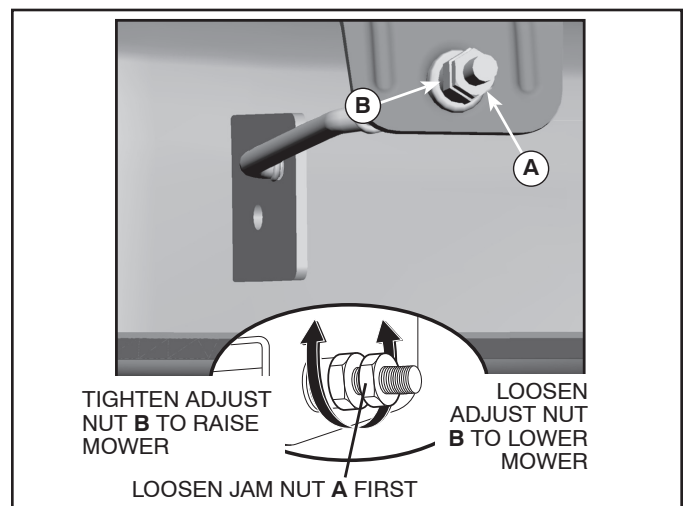

Fig. 34

**NOTE:** Each full turn of the adjustment nut will change mower height about 1/8".

- Recheck measurements, adjust if necessary until front tip of blade is 1/8" to 1/2" lower than the rear tip.
- Hold adjustment nut in position with wrench and tighten jam nut securely against adjustment nut.

# SERVICE AND ADJUSTMENTS

## TO REPLACE MOWER BLADE DRIVE BELT (See Fig. 35)

The mower blade drive belt may be replaced without tools. Park the tractor on level surface. Engage parking brake.

### BELT REMOVAL -

- Remove mower from tractor (See "TO REMOVE MOWER" in this section of manual).
- Work belt off both mandrel pulleys and idler pulleys.
- Pull belt away from mower.

### BELT INSTALLATION -

- Work belt around both mandrel pulleys and idler pulleys.
- Make sure belt is in all pulley grooves and inside all belt guides.
- Install mower (See "TO INSTALL MOWER" in this section of manual).

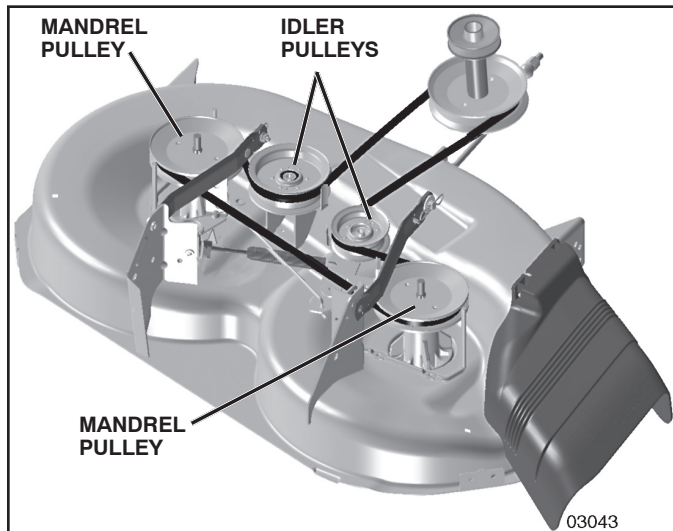

Fig. 35

## TO CHECK BRAKE

If tractor requires more than five (5) feet to stop at highest speed in highest gear on a level, dry concrete or paved surface, then brake must be serviced.

You may also check brake by:

1. Park tractor on a level, dry concrete or paved surface, depress brake pedal all the way down and engage parking brake.
2. Disengage transmission by placing freewheel control in "transmission disengaged" position. Pull freewheel control out and into the slot and release so it is held in the disengaged position.

The rear wheels must lock and skid when you try to manually push the tractor forward. If the rear wheels rotate, then the brake needs to be serviced. Contact a Sears or other qualified service center.

## TO REPLACE MOTION DRIVE BELT (See Fig. 36)

Park the tractor on level surface. Engage parking brake. For assistance, there is a belt installation guide decal on bottom side of left footrest.

### BELT REMOVAL -

- Remove mower (See "TO REMOVE MOWER" section in this manual).

**NOTE:** Observe entire motion drive belt and position of all belt guides and keepers.

- Remove belt from stationary idler (A) and clutching idler (B).
- Remove belt from centerspan idler (C).
- Pull belt slack toward rear of tractor. Carefully remove belt upwards from transmission input pulley and over cooling fan blades (D).
- Remove belt downward from engine pulley (E).
- Slide belt toward rear of tractor, off the steering plate (F) and remove from tractor.

### BELT INSTALLATION -

- Install new belt from tractor rear to front, over the steering plate (F) and above clutch brake pedal shaft (G).
- Pull belt toward front of tractor and roll belt onto engine pulley (E).
- Pull belt toward rear of tractor. Carefully work belt down around transmission cooling fan and onto the input pulley (D). Be sure belt is inside the belt keeper.
- Install belt on centerspan idler (C).
- Install belt through stationary idler (A) and clutching idler (B).
- Make sure belt is in all pulley grooves and inside all belt guides and keepers.
- Install mower (See "TO INSTALL MOWER" section in this manual).

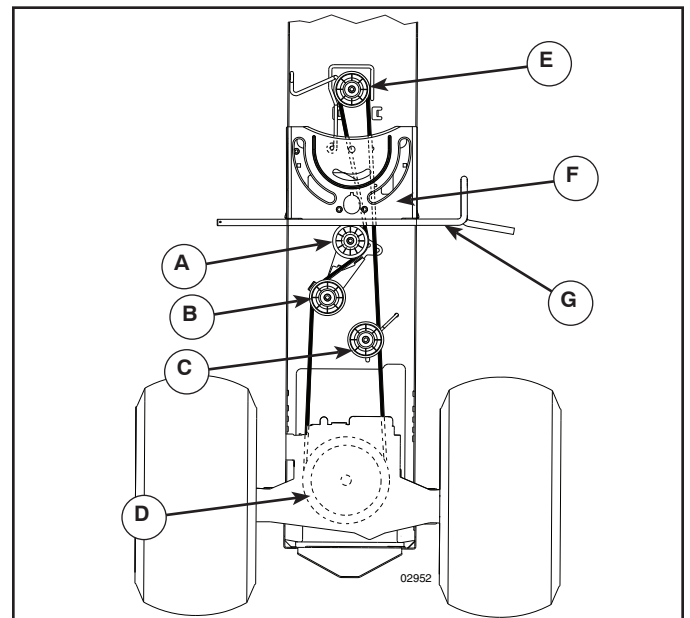

Fig. 36



# SERVICE AND ADJUSTMENTS

## TRANSAXLE MOTION CONTROL LEVER NEUTRAL ADJUSTMENT (See Fig. 37)

The motion control lever has been preset at the factory and adjustment should not be necessary.

- Loosen adjustment bolt in front of the right rear wheel, and lightly tighten.
- Start engine and move motion control lever until tractor does not move forward or backward.
- Hold motion control lever in that position and turn engine off.
- While holding motion control lever in place, loosen the adjustment bolt.
- Move motion control lever to the neutral (lock gate) position.
- Tighten adjustment bolt securely.

**NOTE:** If additional clearance is needed to get to adjustment bolt, move mower deck height to the lowest position.

After above adjustment is made, if the tractor still creeps forward or backward while motion control lever is in neutral position, follow these steps:

- Loosen the adjustment bolt.
- Move the motion control lever 1/4 to 1/2 inch in the direction it is trying to creep.
- Tighten adjustment bolt securely.
- Start engine and test.
- If tractor still creeps, repeat above steps until satisfied.

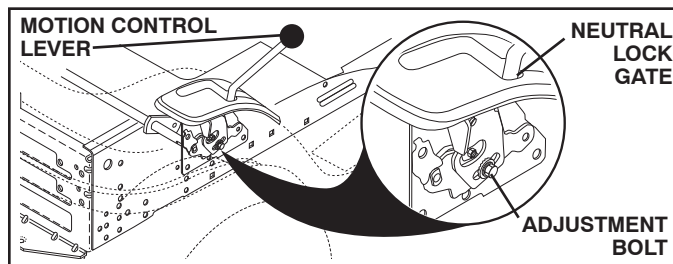

Fig. 37

## TO REMOVE WHEEL (See Fig. 38)

- Block up axle securely.
- Remove axle cover, retaining ring and washers to allow wheel removal (rear wheel contains a square key - Do not lose).
- Repair tire and reassemble.
- On rear wheels only: align grooves in rear wheel hub and axle. Insert square key.
- Replace washers and snap retaining ring securely in axle groove.

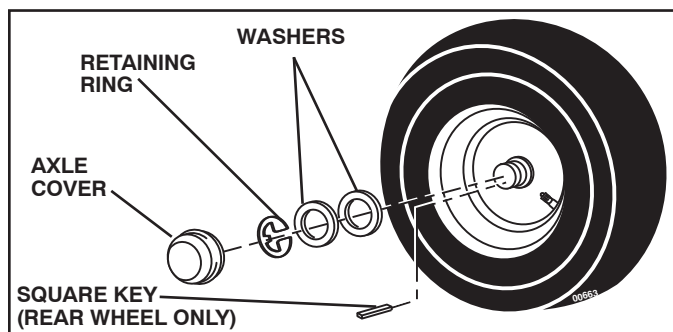

Fig. 38

- Replace axle cover.

**NOTE:** To seal tire punctures and prevent flat tires due to slow leaks, tire sealant may be purchased from your local parts dealer. Tire sealant also prevents tire dry rot and corrosion.

## FRONT WHEEL TOE-IN/CAMBER

Your new tractor front wheel toe-in and camber is set at the factory and is normal. The front wheel toe-in and camber are not adjustable. If damage has occurred to affect the factory set front wheel toe-in or camber, contact a qualified service center.

## TO START ENGINE WITH A WEAK BATTERY (See Fig. 39)



**WARNING: Lead-acid batteries generate explosive gases. Keep sparks, flame and smoking materials away from batteries. Always wear eye protection when around batteries.**

If your battery is too weak to start the engine, it should be recharged. (See "BATTERY" in the MAINTENANCE section of this manual).

If "jumper cables" are used for emergency starting, follow this procedure:

**IMPORTANT:** YOUR TRACTOR IS EQUIPPED WITH A 12 VOLT SYSTEM. THE OTHER VEHICLE MUST ALSO BE A 12 VOLT SYSTEM. DO NOT USE YOUR TRACTOR BATTERY TO START OTHER VEHICLES.

### TO ATTACH JUMPER CABLES -

- Connect one end of the RED cable to the POSITIVE (+) terminal of each battery (A-B), taking care not to short against tractor chassis.
- Connect one end of the BLACK cable to the NEGATIVE (-) terminal (C) of fully charged battery.
- Connect the other end of the BLACK cable (D) to good chassis ground, away from fuel tank and battery.

### TO REMOVE CABLES, REVERSE ORDER -

- BLACK cable first from chassis and then from the fully charged battery.
- RED cable last from both batteries.

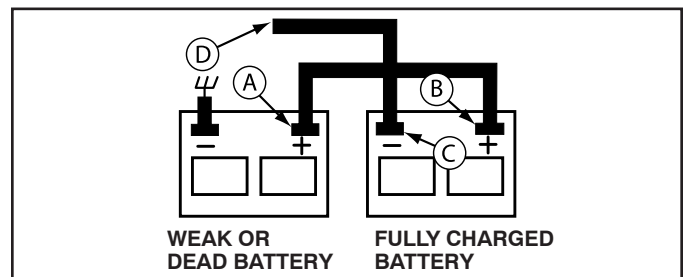

Fig. 39

# SERVICE AND ADJUSTMENTS

## REPLACING BATTERY (See Fig. 40)



**WARNING:** Do not short battery terminals by allowing a wrench or any other object to contact both terminals at the same time. Before connecting battery, remove metal bracelets, wristwatch bands, rings, etc. Positive terminal must be connected first to prevent sparking from accidental grounding.

- Lift seat pan to raised position.
- Disconnect BLACK battery cable first then RED battery cable and carefully remove battery from tractor.
- Install new battery with terminals in same position as old battery.
- First connect RED battery cable to positive (+) terminal with bolt and nut as shown. Tighten securely. Slide terminal cover over terminal.
- Connect BLACK grounding cable to negative (-) terminal with remaining bolt and nut. Tighten securely.
- Lower seat pan.

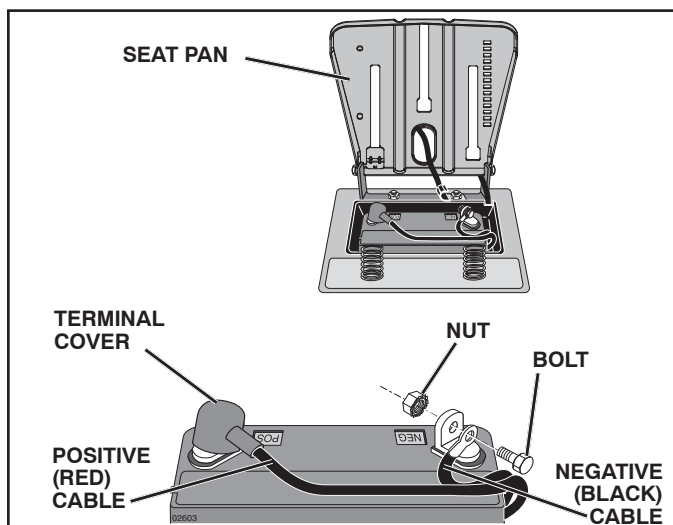

Fig. 40

## TO REPLACE HEADLIGHT BULB

- Raise hood.
- Pull bulb holder out of the hole in the backside of the grill.
- Replace bulb in holder and push bulb holder securely back into the hole in the backside of the grill.
- Close hood.

## INTERLOCKS AND RELAYS

Loose or damaged wiring may cause your tractor to run poorly, stop running, or prevent it from starting.

- Check wiring. See electrical wiring diagram in the Repair Parts section.

## TO REPLACE FUSE

Replace with 20 amp automotive-type plug-in fuse. The fuse holder is located behind the dash.

## TO REMOVE HOOD AND GRILL ASSEMBLY (See Fig. 41)

- Raise hood.
- Unsnap headlight wire connector.
- Stand in front of tractor. Grasp hood at sides, tilt toward engine and lift off of tractor.
- To replace, reverse above procedure.

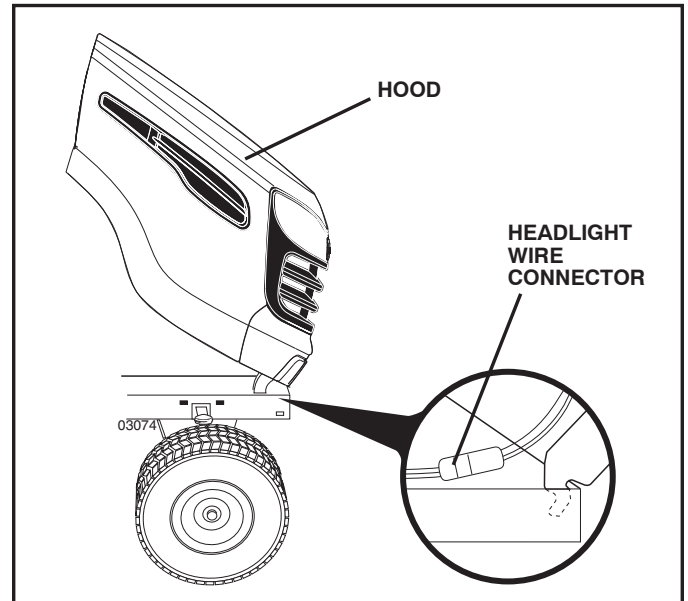

Fig. 41

## TRANSMISSION

### REMOVAL/REPLACEMENT

Should your transmission require removal for service or replacement, it should be purged after reinstallation and before operating the tractor. See "PURGE TRANSMISSION" in the Operation section of this manual.

## ENGINE

### TO ADJUST THROTTLE CONTROL CABLE

The throttle control has been preset at the factory and adjustment should not be necessary. If adjustment is necessary, see engine manual.

### TO ADJUST CHOKE CONTROL

The choke control has been preset at the factory and adjustment should not be necessary. If adjustment is necessary, see engine manual.

### TO ADJUST CARBURETOR

Your carburetor is not adjustable. If your engine does not operate properly due to suspected carburetor problems, take your tractor to an authorized service center for repair and/or adjustment.

# STORAGE

Immediately prepare your tractor for storage at the end of the season or if the tractor will not be used for 30 days or more.



**WARNING:** Never store the tractor with gasoline in the tank inside a building where fumes may reach an open flame or spark. Allow the engine to cool before storing in any enclosure.

## TRACTOR

Remove mower from tractor for winter storage. When mower is to be stored for a period of time, clean it thoroughly, remove all dirt, grease, leaves, etc. Store in a clean, dry area.

- Clean entire tractor (See “CLEANING” in the Maintenance section of this manual).
- Inspect and replace belts, if necessary (See belt replacement instructions in the Service and Adjustments section of this manual).
- Lubricate as shown in the Maintenance section of this manual.
- Be sure that all nuts, bolts and screws are securely fastened. Inspect moving parts for damage, breakage and wear. Replace if necessary.
- Touch up all rusted or chipped paint surfaces; sand lightly before painting.

## BATTERY

- Fully charge the battery for storage.
- After a period of time in storage, battery may require recharging.
- To help prevent corrosion and power leakage during long periods of storage, battery cables should be disconnected and battery cleaned thoroughly (see “TO CLEAN BATTERY AND TERMINALS” in the Maintenance section of this manual).
- After cleaning, leave cables disconnected and place cables where they cannot come in contact with battery terminals.
- If battery is removed from tractor for storage, do not store battery directly on concrete or damp surfaces.

## ENGINE

### FUEL SYSTEM

**IMPORTANT:** IT IS IMPORTANT TO PREVENT GUM DEPOSITS FROM FORMING IN ESSENTIAL FUEL SYSTEM PARTS SUCH AS CARBURETOR, FUEL FILTER, FUEL HOSE, OR TANK DURING STORAGE. ALSO, EXPERIENCE INDICATES THAT ALCOHOL BLENDED FUELS (CALLED GASOHOL OR USING ETHANOL OR METHANOL) CAN ATTRACT MOISTURE WHICH LEADS TO SEPARATION AND FORMATION OF ACIDS DURING STORAGE. ACIDIC GAS CAN DAMAGE THE FUEL SYSTEM OF AN ENGINE WHILE IN STORAGE.

- Empty the fuel tank by starting the engine and let it run until the fuel lines and carburetor are empty.
- Never use engine or carburetor cleaner products in the fuel tank or permanent damage may occur.
- Use fresh fuel next season.

**NOTE:** Fuel stabilizer is an acceptable alternative in minimizing the formation of fuel gum deposits during storage. Add stabilizer to gasoline in fuel tank or storage container. Always follow the mix ratio found on stabilizer container. Run engine at least 10 minutes after adding stabilizer to allow the stabilizer to reach the carburetor. Do not empty the gas tank and carburetor if using fuel stabilizer.

### ENGINE OIL

Drain oil (with engine warm) and replace with clean engine oil. (See “ENGINE” in the Maintenance section of this manual).

### CYLINDER(S)

- Remove spark plug(s).
- Pour one ounce of oil through spark plug hole(s) into cylinder(s).
- Turn ignition key to “START” position for a few seconds to distribute oil.
- Replace with new spark plug(s).

## OTHER

- Do not store gasoline from one season to another.
- Replace your gasoline can if your can starts to rust. Rust and/or dirt in your gasoline will cause problems.
- If possible, store your tractor indoors and cover it to give protection from dust and dirt.
- Cover your tractor with a suitable protective cover that does not retain moisture. Do not use plastic. Plastic cannot breathe which allows condensation to form and will cause your tractor to rust.

**IMPORTANT:** NEVER COVER TRACTOR WHILE ENGINE AND EXHAUST ARE STILL WARM.

# TROUBLESHOOTING

PROBLEM	CAUSE	CORRECTION
<b>Will not start</b>	<ol style="list-style-type: none"> <li>1. Out of fuel.</li> <li>2. Engine not "CHOKED" properly.</li> <li>3. Engine flooded.</li> <li>4. Bad spark plug.</li> <li>5. Dirty air filter.</li> <li>6. Dirty fuel filter.</li> <li>7. Water in fuel.</li>   <li>8. Loose or damaged wiring.</li> <li>9. Carburetor out of adjustment.</li>   <li>10. Engine valves out of adjustment.</li> </ol>	<ol style="list-style-type: none"> <li>1. Fill fuel tank.</li> <li>2. See "TO START ENGINE" in Operation section.</li> <li>3. Wait several minutes before attempting to start.</li> <li>4. Replace spark plug.</li> <li>5. Clean/replace air filter.</li> <li>6. Replace fuel filter.</li> <li>7. Empty fuel tank and carburetor, refill tank with fresh gasoline and replace fuel filter.</li> <li>8. Check all wiring.</li> <li>9. See "To Adjust Carburetor" in Service Adjustments section.</li> <li>10. Contact an authorized service center/department.</li> </ol>
<b>Hard to start</b>	<ol style="list-style-type: none"> <li>1. Dirty air filter.</li> <li>2. Bad spark plug.</li> <li>3. Weak or dead battery.</li> <li>4. Dirty fuel filter.</li> <li>5. Stale or dirty fuel.</li> <li>6. Loose or damaged wiring.</li> <li>7. Carburetor out of adjustment.</li>   <li>8. Engine valves out of adjustment.</li> </ol>	<ol style="list-style-type: none"> <li>1. Clean/replace air filter.</li> <li>2. Replace spark plug.</li> <li>3. Recharge or replace battery.</li> <li>4. Replace fuel filter.</li> <li>5. Empty fuel tank and refill tank with fresh, clean gas.</li> <li>6. Check all wiring.</li> <li>7. See "To Adjust Carburetor" in Service Adjustments section.</li> <li>8. Contact an authorized service center/department.</li> </ol>
<b>Engine will not turn over</b>	<ol style="list-style-type: none"> <li>1. Brake pedal not depressed.</li> <li>2. Attachment clutch is engaged.</li> <li>3. Weak or dead battery.</li> <li>4. Blown fuse.</li> <li>5. Corroded battery terminals.</li> <li>6. Loose or damaged wiring.</li> <li>7. Faulty ignition switch.</li> <li>8. Faulty solenoid or starter.</li> <li>9. Faulty operator presence switch(es).</li> </ol>	<ol style="list-style-type: none"> <li>1. Depress brake pedal.</li> <li>2. Disengage attachment clutch.</li> <li>3. Recharge or replace battery.</li> <li>4. Replace fuse.</li> <li>5. Clean battery terminals.</li> <li>6. Check all wiring.</li> <li>7. Check/replace ignition switch.</li> <li>8. Check/replace solenoid or starter.</li> <li>9. Contact an authorized service center/department.</li> </ol>
<b>Engine clicks but will not start</b>	<ol style="list-style-type: none"> <li>1. Weak or dead battery.</li> <li>2. Corroded battery terminals.</li> <li>3. Loose or damaged wiring.</li> <li>4. Faulty solenoid or starter.</li> </ol>	<ol style="list-style-type: none"> <li>1. Recharge or replace battery.</li> <li>2. Clean battery terminals.</li> <li>3. Check all wiring.</li> <li>4. Check/replace solenoid or starter.</li> </ol>
<b>Loss of power</b>	<ol style="list-style-type: none"> <li>1. Cutting too much grass/too fast.</li> <li>2. Throttle in "CHOKE" position.</li> <li>3. Build-up of grass, leaves, trash under mower.</li> <li>4. Dirty air filter.</li> <li>5. Low oil level/dirty oil.</li> <li>6. Faulty spark plug.</li> <li>7. Dirty fuel filter.</li> <li>8. Stale or dirty fuel.</li> <li>9. Water in fuel.</li>   <li>10. Spark plug wire loose.</li> <li>11. Dirty engine air screen/fins.</li> <li>12. Dirty/clogged muffler.</li> <li>13. Loose or damaged wiring.</li> <li>14. Carburetor out of adjustment.</li> <li>15. Engine valves out of adjustment.</li> </ol>	<ol style="list-style-type: none"> <li>1. Raise cutting height/reduce speed.</li> <li>2. Adjust throttle control.</li> <li>3. Clean underside of mower housing.</li> <li>4. Clean/replace air filter.</li> <li>5. Check oil level/change oil.</li> <li>6. Clean and regap or change spark plug.</li> <li>7. Replace fuel filter.</li> <li>8. Empty fuel tank and refill tank with fresh, clean gas.</li> <li>9. Empty fuel tank and carburetor, refill tank with fresh gasoline and replace fuel filter.</li> <li>10. Connect and tighten spark plug wire.</li> <li>11. Clean engine air screen/fins.</li> <li>12. Clean/replace muffler.</li> <li>13. Check all wiring.</li> <li>14. See "To Adjust Carburetor" in Service Adjustments section.</li> <li>15. Contact an authorized service center/department.</li> </ol>
<b>Excessive vibration</b>	<ol style="list-style-type: none"> <li>1. Worn, bent or loose blade.</li> <li>2. Bent blade mandrel.</li> <li>3. Loose/damaged part(s).</li> </ol>	<ol style="list-style-type: none"> <li>1. Replace blade. Tighten blade bolt.</li> <li>2. Replace blade mandrel.</li> <li>3. Tighten loose part(s). Replace damaged parts.</li> </ol>

# TROUBLESHOOTING

PROBLEM	CAUSE	CORRECTION
<b>Engine continues to run when operator leaves seat with attachment clutch engaged</b>	<ol style="list-style-type: none"> <li>1. Faulty operator-safety presence control system.</li> </ol>	<ol style="list-style-type: none"> <li>1. Check wiring, switches and connections. If not corrected, contact an authorized service center/department.</li> </ol>
<b>Poor cut - uneven</b>	<ol style="list-style-type: none"> <li>1. Worn, bent or loose blade.</li> <li>2. Mower deck not level.</li> <li>3. Buildup of grass, leaves, trash under mower.</li> <li>4. Bent blade mandrel.</li> <li>5. Clogged mower deck vent holes from buildup of grass, leaves, and trash around mandrels.</li> </ol>	<ol style="list-style-type: none"> <li>1. Replace blade. Tighten blade bolt.</li> <li>2. Level mower deck.</li> <li>3. Clean underside of mower housing.</li> <li>4. Replace blade mandrel.</li> <li>5. Clean around mandrels to open vent holes.</li> </ol>
<b>Mower blades will not rotate</b>	<ol style="list-style-type: none"> <li>1. Obstruction in clutch mechanism.</li> <li>2. Worn/damaged mower drive belt.</li> <li>3. Frozen idler pulley.</li> <li>4. Frozen blade mandrel.</li> </ol>	<ol style="list-style-type: none"> <li>1. Remove obstruction.</li> <li>2. Replace mower drive belt.</li> <li>3. Replace idler pulley.</li> <li>4. Replace blade mandrel.</li> </ol>
<b>Poor grass discharge</b>	<ol style="list-style-type: none"> <li>1. Engine speed too slow.</li> <li>2. Travel speed too fast.</li> <li>3. Wet grass.</li> <li>4. Mower deck not level.</li> <li>5. Low/uneven tire air pressure.</li> <li>6. Worn, bent or loose blade.</li> <li>7. Buildup of grass, leaves, trash under mower.</li> <li>8. Mower drive belt worn.</li> <li>9. Blades improperly installed.</li> <li>10. Improper blades used.</li> <li>11. Clogged mower deck vent holes from buildup of grass, leaves, trash around mandrels.</li> </ol>	<ol style="list-style-type: none"> <li>1. Place throttle control in "FAST" position.</li> <li>2. Shift to slower speed.</li> <li>3. Allow grass to dry before mowing.</li> <li>4. Level mower deck.</li> <li>5. Check tires for proper air pressure.</li> <li>6. Replace blade. Tighten blade bolt.</li> <li>7. Clean underside of mower housing.</li> <li>8. Replace mower drive belt.</li> <li>9. Reinstall blades sharp edge down.</li> <li>10. Replace with blades listed in parts manual.</li> <li>11. Clean around mandrels to open vent holes.</li> </ol>
<b>Headlight(s) not working (if so equipped)</b>	<ol style="list-style-type: none"> <li>1. Switch is "OFF".</li> <li>2. Bulb(s) or lamp(s) burned out.</li> <li>3. Faulty light switch.</li> <li>4. Loose or damaged wiring.</li> <li>5. Blown fuse.</li> </ol>	<ol style="list-style-type: none"> <li>1. Turn switch "ON".</li> <li>2. Replace bulb(s) or lamp(s).</li> <li>3. Check/replace light switch.</li> <li>4. Check wiring and connections.</li> <li>5. Replace fuse.</li> </ol>
<b>Battery will not charge</b>	<ol style="list-style-type: none"> <li>1. Bad battery cell(s).</li> <li>2. Poor cable connections.</li> <li>3. Faulty regulator (if so equipped).</li> <li>4. Faulty alternator.</li> </ol>	<ol style="list-style-type: none"> <li>1. Replace battery.</li> <li>2. Check/clean all connections.</li> <li>3. Replace regulator.</li> <li>4. Replace alternator.</li> </ol>
<b>Loss of drive</b>	<ol style="list-style-type: none"> <li>1. Freewheel control in "disengaged" position.</li> <li>2. Debris on steering plate (if equipped).</li> <li>3. Motion drive belt worn, damaged, or broken.</li> <li>4. Air trapped in transmission during shipment or servicing.</li> <li>5. Axle key missing.</li> </ol>	<ol style="list-style-type: none"> <li>1. Place freewheel control in "engaged" position.</li> <li>2. See "CLEANING" in the maintenance section.</li> <li>3. Replace motion drive belt.</li> <li>4. Purge transmission.</li> <li>5. Install axle key at rear wheel. See "TO REMOVE WHEEL" in the Service and Adjustments section.</li> </ol>
<b>Engine "back-fires" when turning engine "OFF"</b>	<ol style="list-style-type: none"> <li>1. Engine throttle control not set between half and full speed (fast) position before stopping engine.</li> </ol>	<ol style="list-style-type: none"> <li>1. Move throttle control between half and full speed (fast) position before stopping engine.</li> </ol>
<b>Engine dies when tractor is shifted into reverse</b>	<ol style="list-style-type: none"> <li>1. Reverse operation system (ROS) is not "ON" while mower or other attachment is engaged.</li> </ol>	<ol style="list-style-type: none"> <li>1. Turn ignition key to ROS "ON" position. See Operation section.</li> </ol>

# TRACTOR - - MODEL NUMBER 944.600100

## DECALS

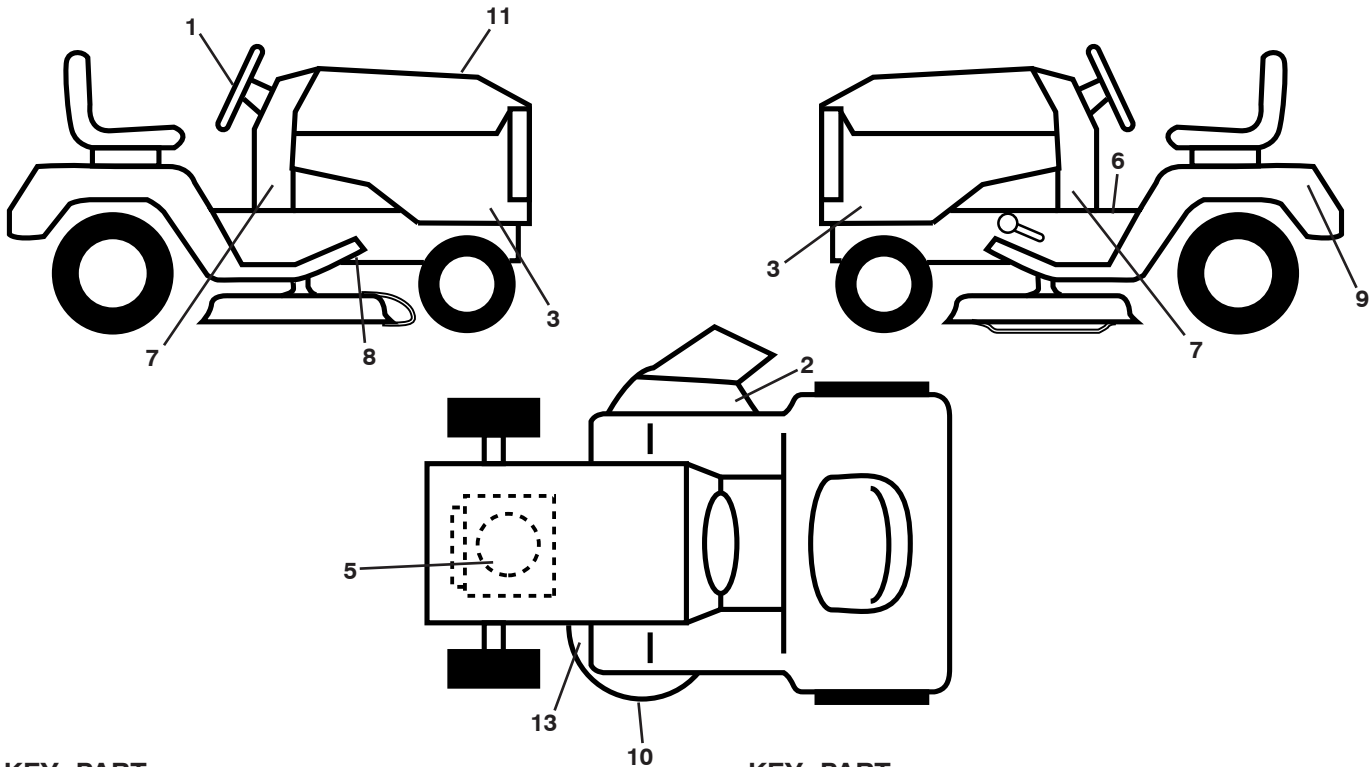

KEY PART NO.	NO.	DESCRIPTION	KEY PART NO.	NO.	DESCRIPTION
1	422885	Decal, Steering	10	426593	Decal, Tractor Precision Cut
2	170563	Decal, Mower Warn.	11	434770	Decal, Replacement
3	434793	Decal, PNL SD RH/LH	13	160396	Decal, Mower V-Belt SCH.
5	426026	Decal, Engine HP	--	193226X428	Pad, Footrest LH
6	411658	Decal, Fender Operator's	--	193227X428	Pad, Footrest RH
7	425786	Decal, Lower Dash	--	166960	Decal, Bypass
8	421534	Decal, V-Belt Schematic Drive	--	434833	Manual, Owner's (English)
9	149517	Decal, Battery Dnge/Poi	--	434834	Manual, Owner's (French)

## WHEELS AND TIRES

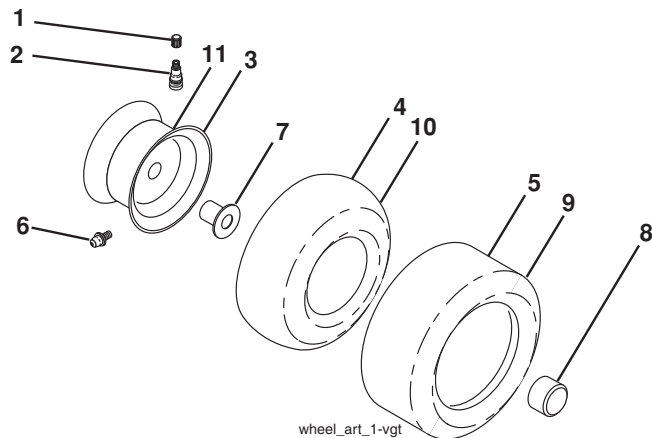

KEY PART NO.	NO.	DESCRIPTION
1	59192	Cap, Valve, Tire
2	65139	Stem, Valve
3	106732X613	Rim Assembly, Front
4	59904	Tube, Front
5	106222X	Tire, Front
6	278H	Fitting, Grease
7	9040H	Bearing, Flange
8	104757X613	Cap, Axle (Front Wheel Only)
9	420531	Tire, 18 x 9.5-8 TurfSaver LT
10	7152J	Tube, Rear
11	106108X613	Rim Assembly, Rear
--	144334	Sealant, Tire (10 oz. Tube)

**NOTE:** All component dimensions given in U.S. inches  
1 inch = 25.4 mm

# TRACTOR - - MODEL NUMBER 944.600100

## SCHEMATIC

SCH11

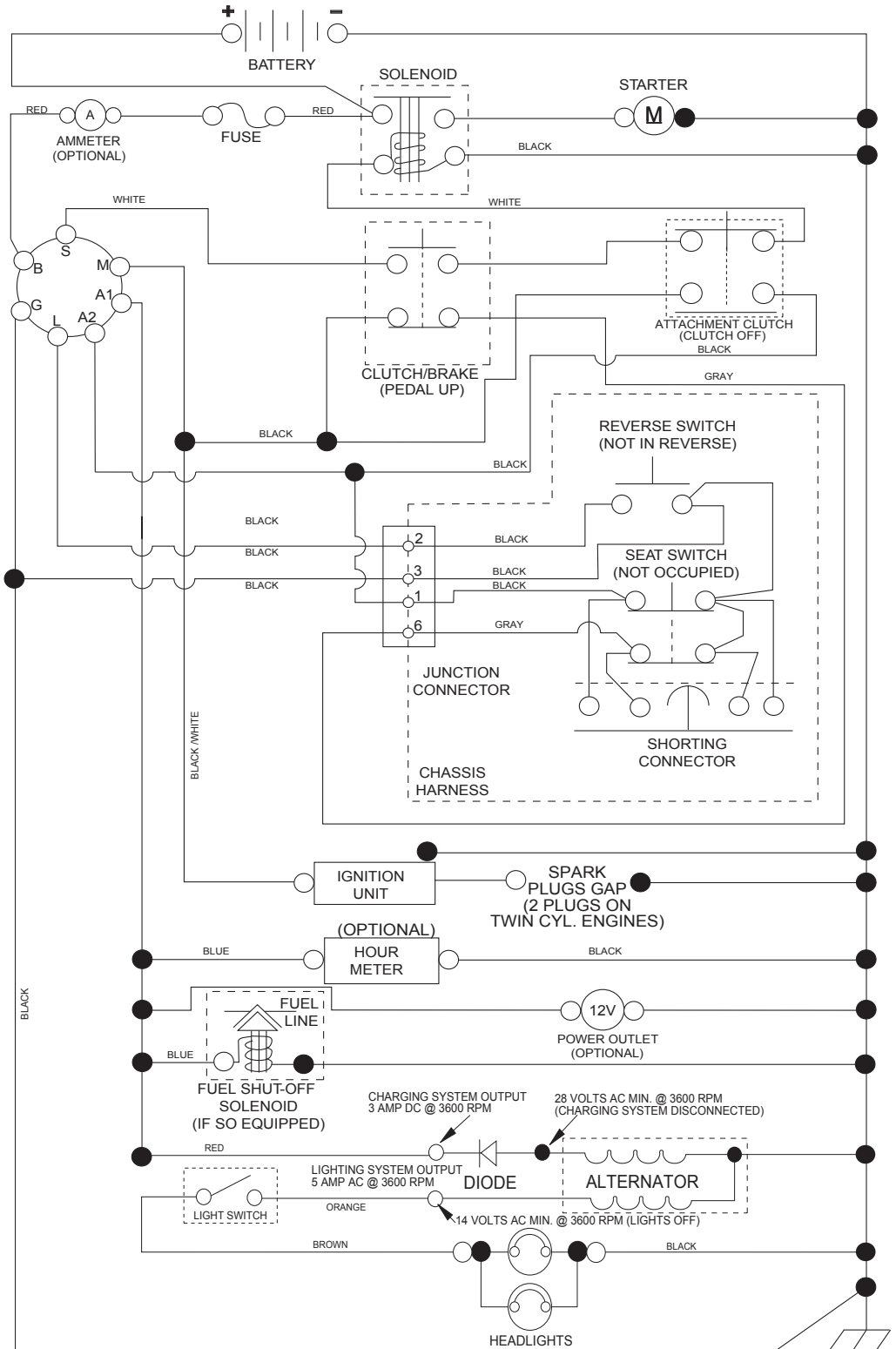

**NOTE**  
YOUR TRACTOR IS EQUIPPED WITH A SPECIAL ALTERNATOR SYSTEM. THE LIGHTS ARE NOT CONNECTED TO THE BATTERY, BUT HAVE THEIR OWN ELECTRICAL SOURCE. BECAUSE OF THIS, THE BRIGHTNESS OF THE LIGHTS WILL CHANGE WITH ENGINE SPEED. AT IDLE THE LIGHTS WILL DIM. AS THE ENGINE IS SPEEDED UP, THE LIGHTS WILL BECOME THEIR BRIGHTEST.

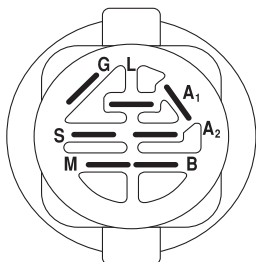

IGNITION SWITCH

POSITION	CIRCUIT	"MAKE"
OFF	M+G+A1	
RUN/OVERRIDE	B+A1	
RUN	B+A1	L+A2
START	B + S + A1	

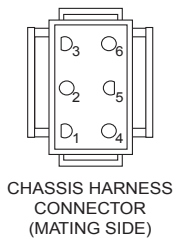

CHASSIS HARNESS CONNECTOR (MATING SIDE)

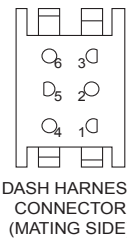

DASH HARNESS CONNECTOR (MATING SIDE)

WIRING INSULATED CLIPS  
NOTE: IF WIRING INSULATED CLIPS WERE REMOVED FOR SERVICING OF UNIT, THEY SHOULD BE RE-INSTALLED TO PROPERLY SECURE YOUR WIRING.

NON-REMOVABLE CONNECTIONS

REMOVABLE CONNECTIONS

# TRACTOR - - MODEL NUMBER 944.600100

## ELECTRICAL

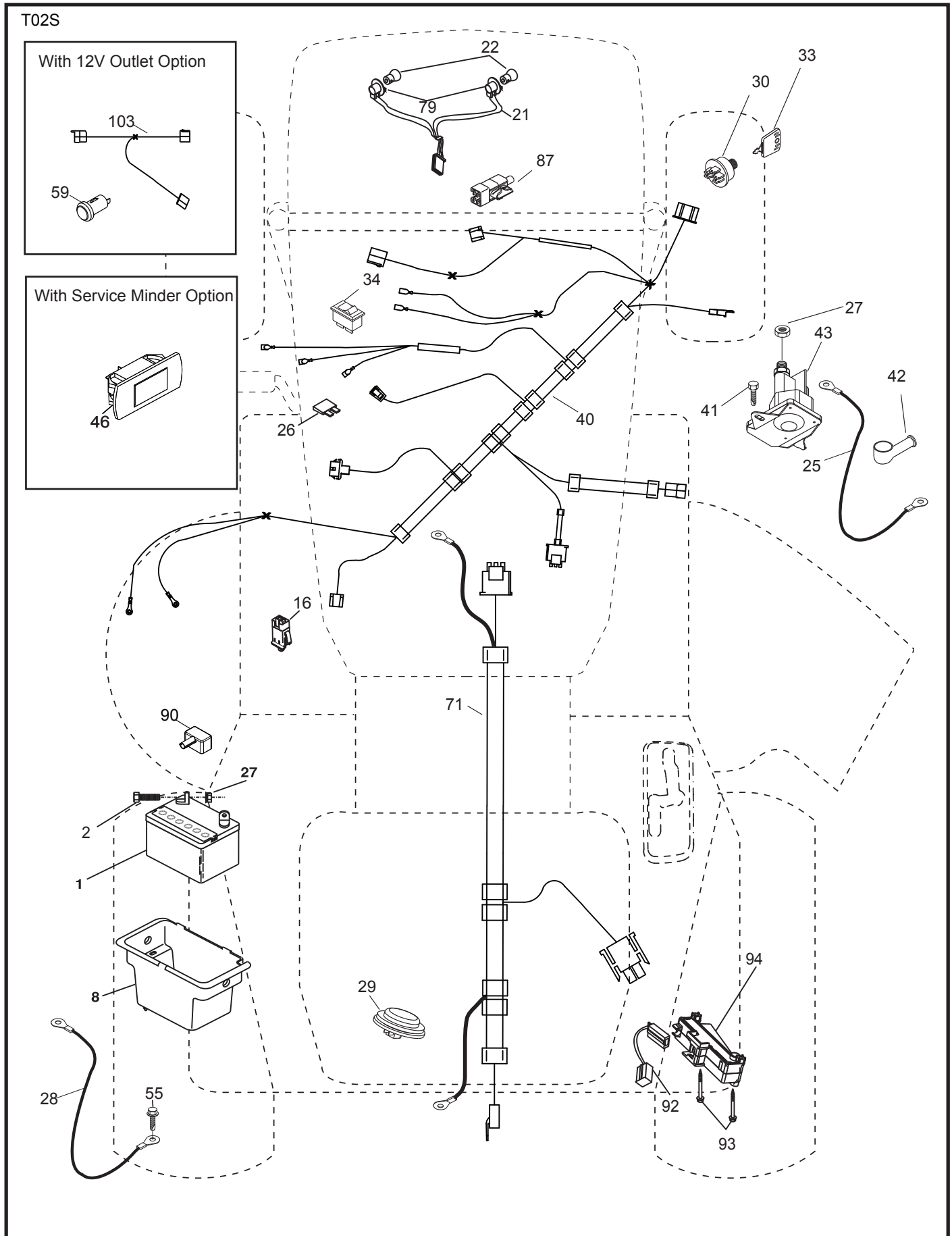



# TRACTOR - - MODEL NUMBER 944.600100

## ELECTRICAL

KEY NO.	PART NO.	DESCRIPTION
1	163465	Battery
2	74760412	Bolt Hex Hd 1/4-20 unc x 3/4
8	193228	Box Battery
16	176138	Switch Interlock Push-In
21	400252	Harness Socket Light w/4152J
22	4152J	Bulb Light
25	412894	Cable Starter 6 Ga. 14.5"
26	175158	Fuse
27	73510400	Nut Keps Hex 1/4-20 unc
28	198885	Cable, Ground
29	401545	Switch, Seat
30	193350	Switch, Ign
33	411934	Key/Chain
34	110712X	Switch Light / Reset
40	401098	Harness Ign. Dash
41	17720408	Screw Thd Cut 1/4-20 x 1/2
42	131563	Cover, Terminal
43	192507	Solenoid
55	17060512	Screw Thdrol 5/16-18 x 3/4 TYTT
71	400449	Harness Ign. Chassis
79	175242	Bulbholder Asm. Incan Descent
87	197802	Switch Interlock Clutch Cable
90	400725	Cover Terminal Battery
92	196615	Harness Pigtail Reverse Switch
93	192540	Screw Plastite 10 - 14 x 2 00
94	191834	Module Reverse Ros

**NOTE:** All component dimensions given in U.S. inches  
1 inch = 25.4 mm

# TRACTOR - - MODEL NUMBER 944.600100

## CHASSIS

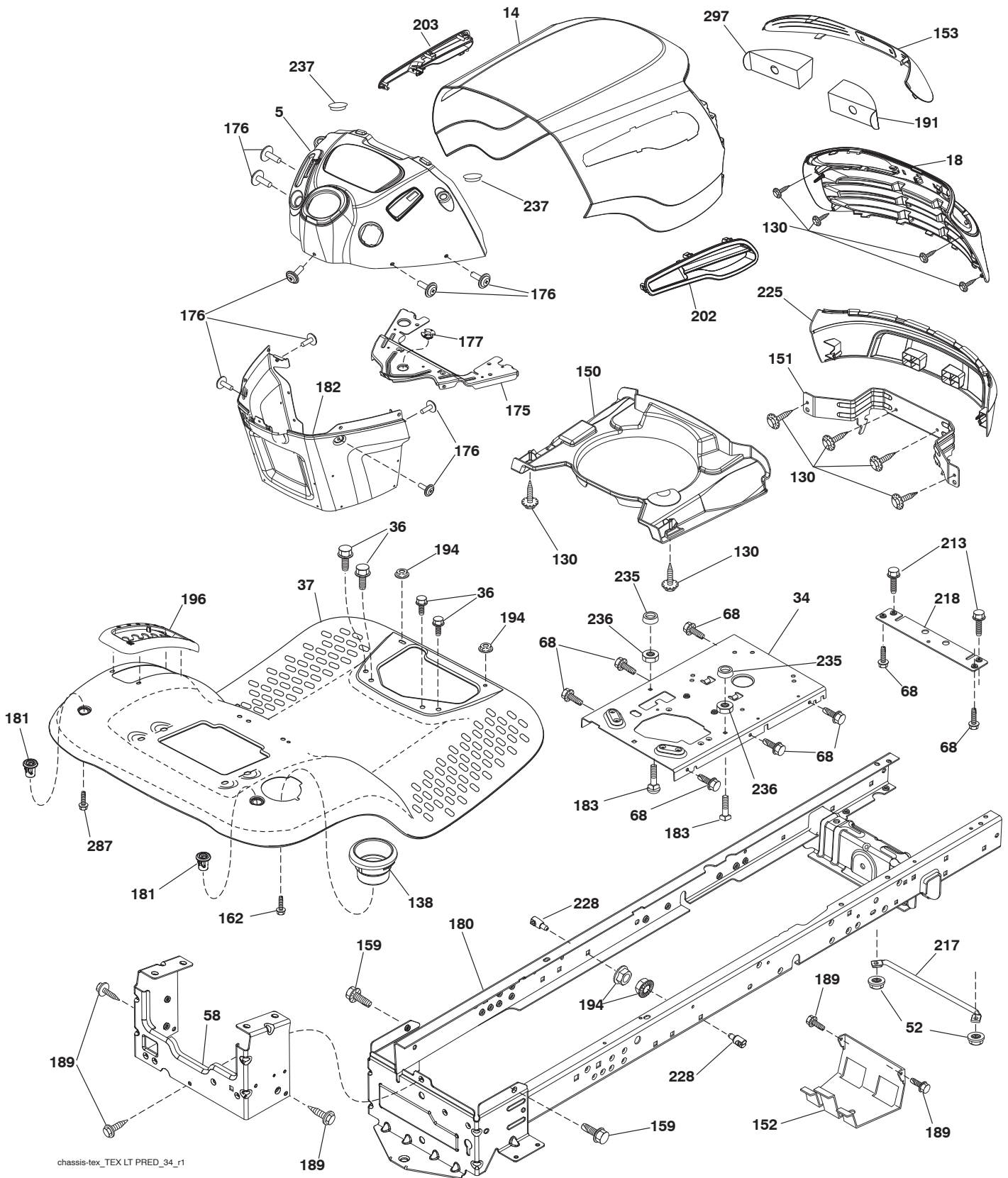

chassis-tex\_TEX LT PRED\_34\_r1

# TRACTOR - - MODEL NUMBER 944.600100

## CHASSIS

KEY NO.	PART NO.	DESCRIPTION
5	400801X428	Dash
14	198416X613	Hood
18	423156	Grille
34	196125	Plate Engine
36	17060512	Screw 5/16-18 x 3/4
37	414872X613	Fender
52	73680500	Nut Crown Lock 5/16-18
58	412280	Drawbar Upper
68	17490508	Screw Thdrol 5/16-18 x 1/2
130	416358	Screw # 10 x .750 BOS Thread
138	193224X428	Cupholder
150	400267	Duct Heat Hood
151	187568	Bracket Pivot
152	199535	Shield Browning/Debris
153	400550X599	Lens
159	17000612	Screw Hexwsh Thdrol 3/8-16 x 3/4
162	142432	Screw Hex Wsh Hi-Lo 1/4 x 1/2
175	199472	Crossmember
176	400776	Screw 10-24 x 5/8 Wshd Qdrx
177	195228	Bushing Steering
180	415063	Chassis
181	193102X428	Bushing Mtg. Fender Crgo.
182	407176	Dash Lower
183	74520520	Bolt Full Thread 5/16-18 x 1-1/4
189	17000512	Screw 5/16 - 18 x 3/4
191	416502	Insert Reflective RH
194	73900500	Nut Lock Hex Flange 5/16-18
196	414579	Console Asm. Deck Lift
202	423173	Vent Side Hood RH
203	423172	Vent Side Hood LH
213	74760512	Bolt Hex Hd 5/16-18 unc x 3/4
217	409167	Rod Pivot Chassis
218	196395	X-Piece Hood Stop
225	400549X613	Bumper
228	195161	Stud Fastener
235	406129	Spacer Fender
236	73930500	Nut Center Lock 5/16-18
237	403704	Plug Mount Cargo
287	17600406	Screw Hex Washead 1/4-20 x 3/8
297	401827	Insert Reflective LH

**NOTE:** All component dimensions given in U.S. inches  
1 inch = 25.4 mm

# TRACTOR - - MODEL NUMBER 944.600100

## DRIVE

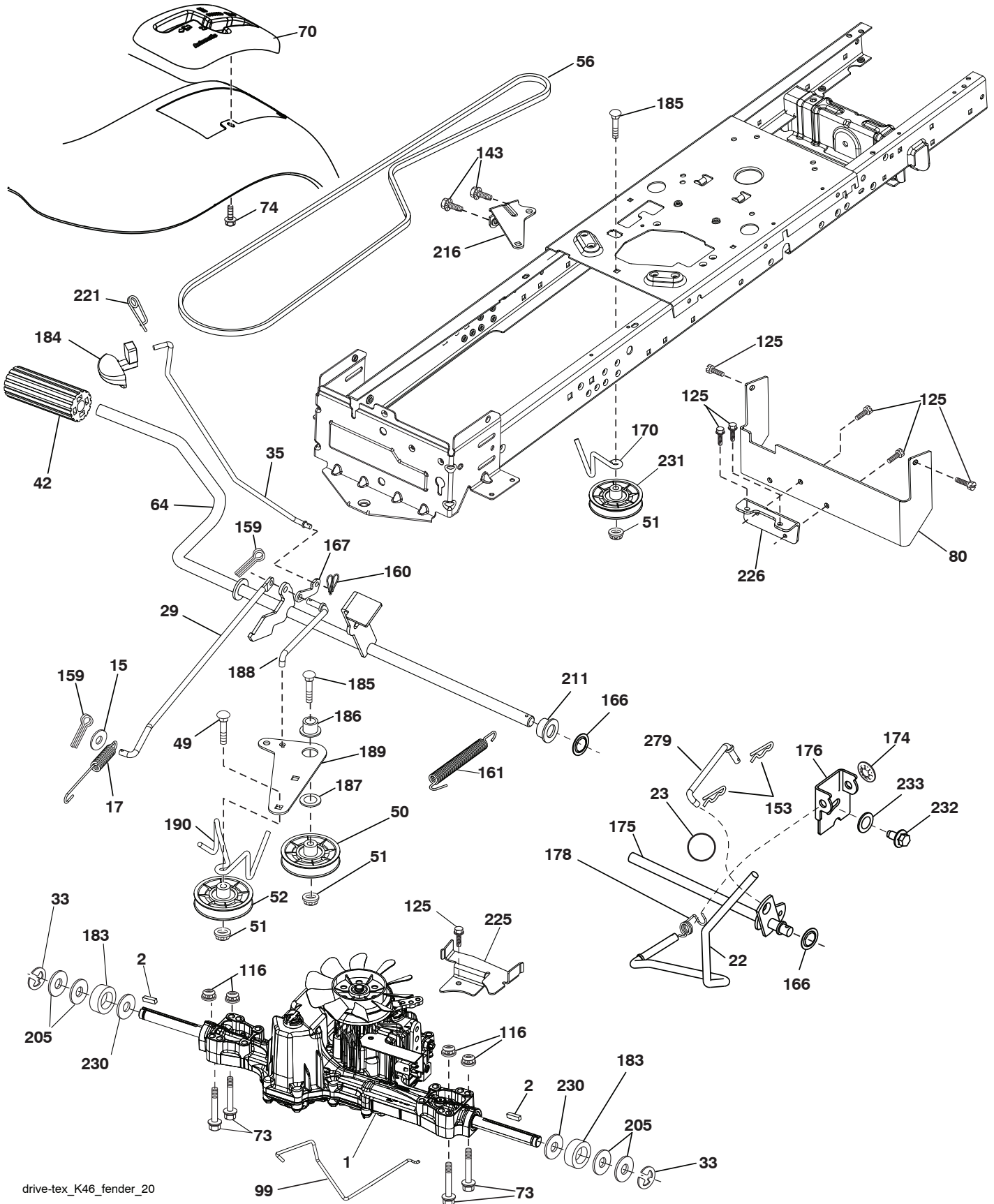

drive-tex\_K46\_fender\_20

## TRACTOR - - MODEL NUMBER 944.600100

### DRIVE

KEY NO.	PART NO.	DESCRIPTION	KEY NO.	PART NO.	DESCRIPTION
1	-----	Transaxle, K46BA (See Breakdown)	167	405257	Latch Brake Parking
2	123583X	Key	170	413430	Keeper Belt Centerspan
15	19131316	Washer 13/32 x 13/16 x 16 Ga.	174	197289	Nut Push
17	413678	Spring, Brake	175	408539	Shaft Asm. Shift
22	197660	Rod Shift	176	196214	Arm Clevis Rod Shift
23	140845	Knob Deluxe	178	197456	Spring Shift
29	403806	Rod, Brake	183	137057	Spacer Axle
33	12000001	Ring E	184	199996X505	Handle Parking Brake
35	401031	Rod, Brake, Park	185	72110622	Bolt
42	8883R	Cover, Foot Pedal	186	194321	Spacer Retainer
49	72110614	Bolt	187	19133210	Washer
50	194327	Pulley Idler Flat	188	194323	Link Clutch Ground Drive
51	73900600	Lock Nut 3/8-16	189	194317	Bellcrank Ground Drive
52	194326	Idler V-Groove 910" Offset	190	194318	Keeper Bellcrank Ground Drive
56	130969	V-Belt, Drive	205	121748X	Washer 25/32 x 1-5/8 x 16 Ga.
64	196200	Shaft Asm. Pedal Brake Control	211	196212	Bearing Shaft Brake
70	193220X428	Console Shift	216	196131	Bracket Pulley Idler
73	74490544	Bolt Hex Flghd 5/16-18 Gr. 5	221	403187	Retainer Spring Clip Handle
74	142432	Screw Hex Wsh Hi-Lo 1/4 x 1/2 unc	225	403319	Keeper Belt Transaxle
80	410024	Strap Torque	226	401564	Bracket Mount Torque
99	415742	Rod Spring Bypass	230	188967	Washer Hardened
116	73900500	Nut Lock Hex Flange 5/16-18	231	407287	Idler V-Groove 1.688" Off Centerspan
125	17000512	Screw 5/16-18 x 3/4	232	74780716	Bolt fin Hex 7/16-14 x 1 Gr. 5
143	17490508	Screw 5/16-18 x 1/2	233	405296	Washer Serrated
153	4497H	Retainer Spring	279	413150	Link Shift T/A
159	76020412	Pin Cotter 1/8 x 3/4			
160	169484	Retainer Clip			
161	105709X	Spring, Return, Clutch			
166	429164	Nut Push			

**NOTE:** All component dimensions given in U.S. inches  
1 inch = 25.4 mm

# TRACTOR - - MODEL NUMBER 944.600100

## ENGINE

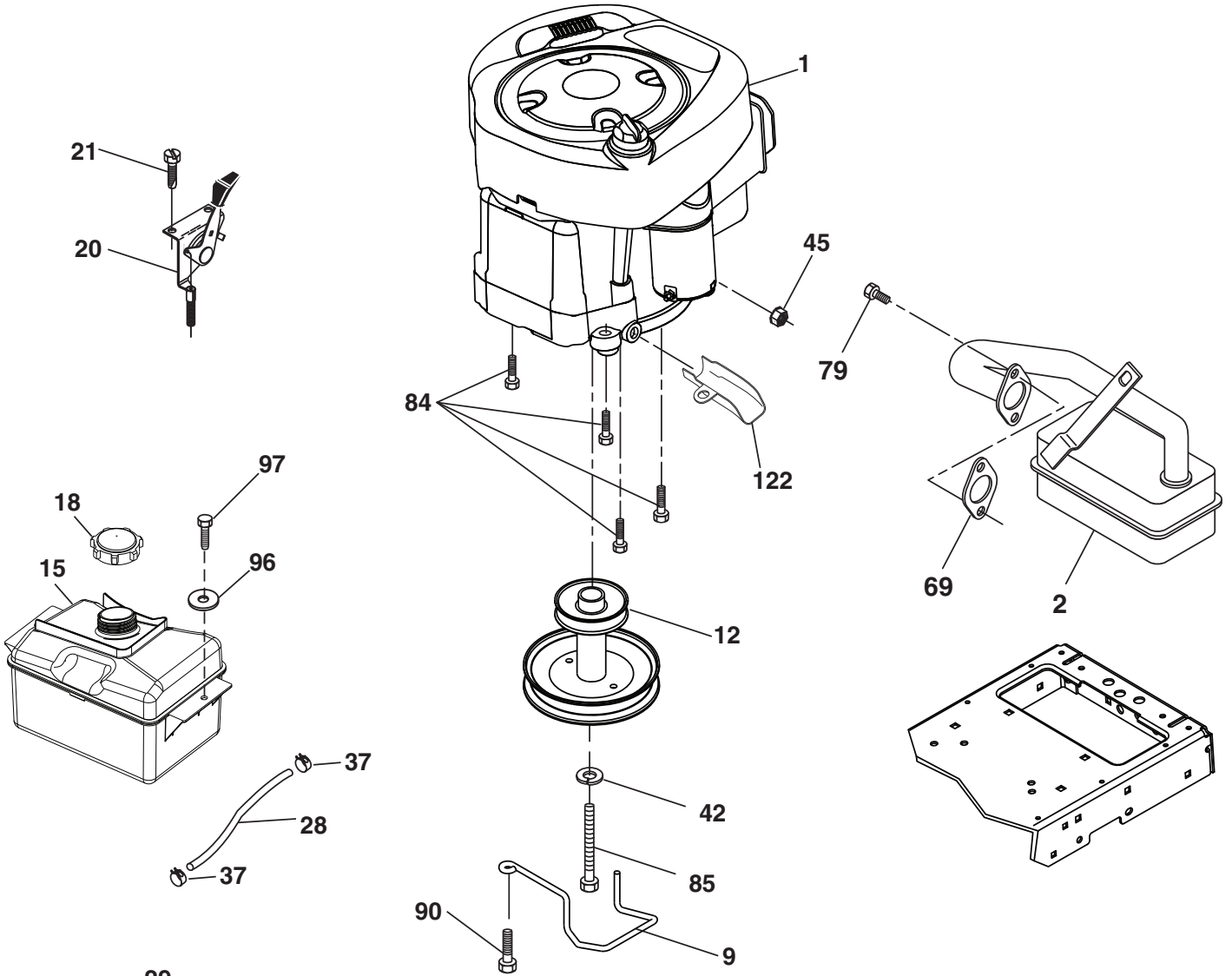

**OPTIONAL EQUIPMENT**  
**Spark Arrester**

engine-tex\_BS\_36

# TRACTOR - - MODEL NUMBER 944.600100

## ENGINE

KEY NO.	PART NO.	DESCRIPTION
1	-----	Engine B&S Model No. 31P677-0804-B1 (See Engine Breakdown)
2	137352	Muffler
9	194320	Keeper Belt Engine
12	405471	Pulley Engine
15	407545	Tank Fuel
18	430220	Cap Asm Fuel
20	170545	Control Throttle/Choke
21	416358	Screw 10 x .750 BOS Thread
28	137040	Fuel Line
29	137180	Spark Arrester Kit
37	123487X	Clamp Hose
42	10040700	Washer Lock 7/16
45	73510400	Nut Keps Hex 1/4-20 unc
69	165291	Gasket
79	192334	Screw 5/16-18 x .75
84	17060620	Screw 3/8-16 x 1-1/4
85	173937	Bolt Hex 7/16-20 x 4 x Gr. 5-1.5
90	17000616	Screw 3/8-16 x 1.0
96	19091416	Washer 9/32 x 7/8 x 16 Ga.
97	17670412	Screw 1/4-20 x 3/4
122	421922	Extension Drain Oil

**NOTE:** All component dimensions given in U.S. inches  
1 inch = 25.4 mm

For engine service and replacement parts, call the toll free number for your engine manufacturer listed below:

Briggs & Stratton      1-800-233-3723

## ENGINE POWER RATING INFORMATION

The gross power rating for individual gas engine models is labeled in accordance with SAE (Society of Automotive Engineers) code J1940 (Small Engine Power & Torque Rating Procedure), and rating performance has been obtained and corrected in accordance with SAE J1995 (Revision 2002-05). Torque values are derived at 3060 RPM; horsepower values are derived at 3600 RPM. Actual gross engine power will be lower and is affected by, among other things, ambient operating conditions and engine-to-engine variability. Given both the wide array of products on which engines are placed and the variety of environmental issues applicable to operating the equipment, the gas engine will not develop the rated gross power when used in a given piece of power equipment (actual "on-site" or net power). This difference is due to a variety of factors including, but not limited to, accessories (air cleaner, exhaust, charging, cooling, carburetor, fuel pump, etc.), application limitations, ambient operating conditions (temperature, humidity, altitude), and engine-to-engine variability. Due to manufacturing and capacity limitations, Briggs & Stratton may substitute an engine of higher rated power for this Series engine.

# TRACTOR - - MODEL NUMBER 944.600100

## STEERING ASSEMBLY

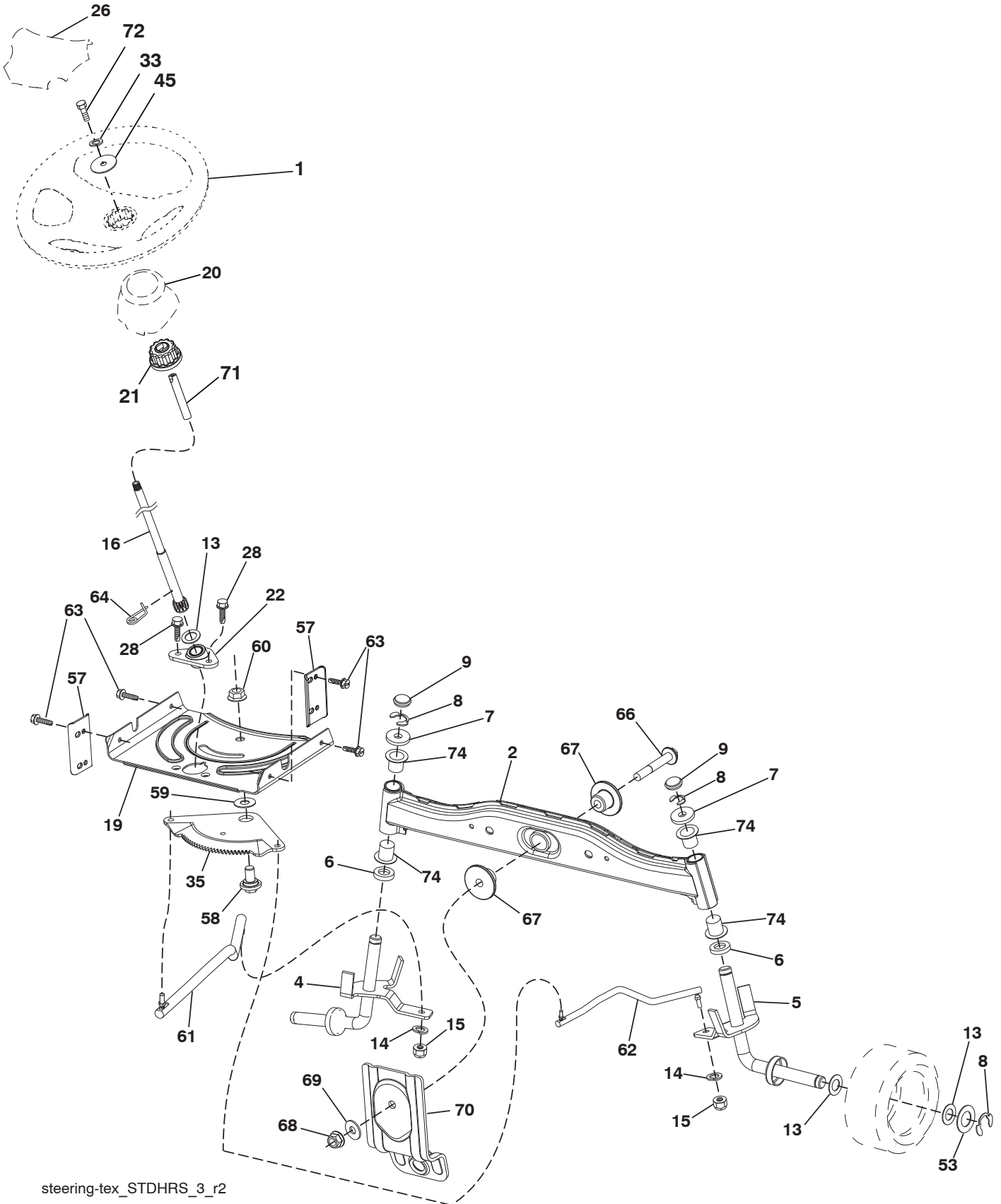

steering-tex\_STDHRS\_3\_r2



# TRACTOR - - MODEL NUMBER 944.600100

## STEERING ASSEMBLY

KEY NO.	PART NO.	DESCRIPTION
1	414803X428	Wheel, Steering
2	418168	Axle Asm., Front
4	403087	Spindle Asm., LH
5	403088	Spindle Asm., RH
6	6266H	Bearing, Race Thrust Harden
7	121748X	Washer 25/32 x 1-5/8 x 16 Ga.
8	12000029	Ring, Klip #T5304-75
9	121232X	Cap, Spindle
13	121749X	Washer 25/32 x 1-1/4 x 16 Ga.
14	STD551137	Washer, Lock Hvy Hlcl Spr 3/8
15	73540600	Nut, Crown Lock 3/8-24 unf
16	429374	Shaft Steering
19	194729	Plate Steering
20	400803X428	Boot, Steering
21	186737	Adapter, Wheel Steering
22	420537	Strg. Supt. Lower
26	414852X428	Insert, Wheel Steering
28	17000612	Screw 3/8-16 x 3/4
33	10040500	Washer Lock 5/16
35	194732	Gear, Sector Plate
45	19113812	Washer 11/32 ID x 2-3/8 OD x 12 Ga.
53	188967	Washer Hardened .793 x 1.637 x .060
57	407465	Bracket Upstop
58	194747	Bolt Shoulder Sector Pivot CFM
59	194748	Washer Thrust Sector Steering
60	73971000	Nut Flange Lock 5/8-11
61	194740	Draglink LH
62	194741	Draglink, RH
63	17000512	Screw 5/16-18 x 3/4
64	199849	Retainer Clip Spring Steering
66	71020748	Bolt Hex Fghd 7/16-14 x 3 Serr
67	194737	Bushing PM Front Axle
68	73900700	Nut Lock Flange 7/16-14 Gr. 5
69	199162	Washer 1.5 x .505 x .118
70	196197	Bracket Deck Susp. Front
71	190752	Shaft Ext.
72	428982	Bolt 5/16-18 x 4 w/patch
74	3366R	Bearing Col Strg

**NOTE:** All component dimensions given in U.S. inches  
1 inch = 25.4 mm

# TRACTOR - - MODEL NUMBER 944.600100

## MOWER DECK

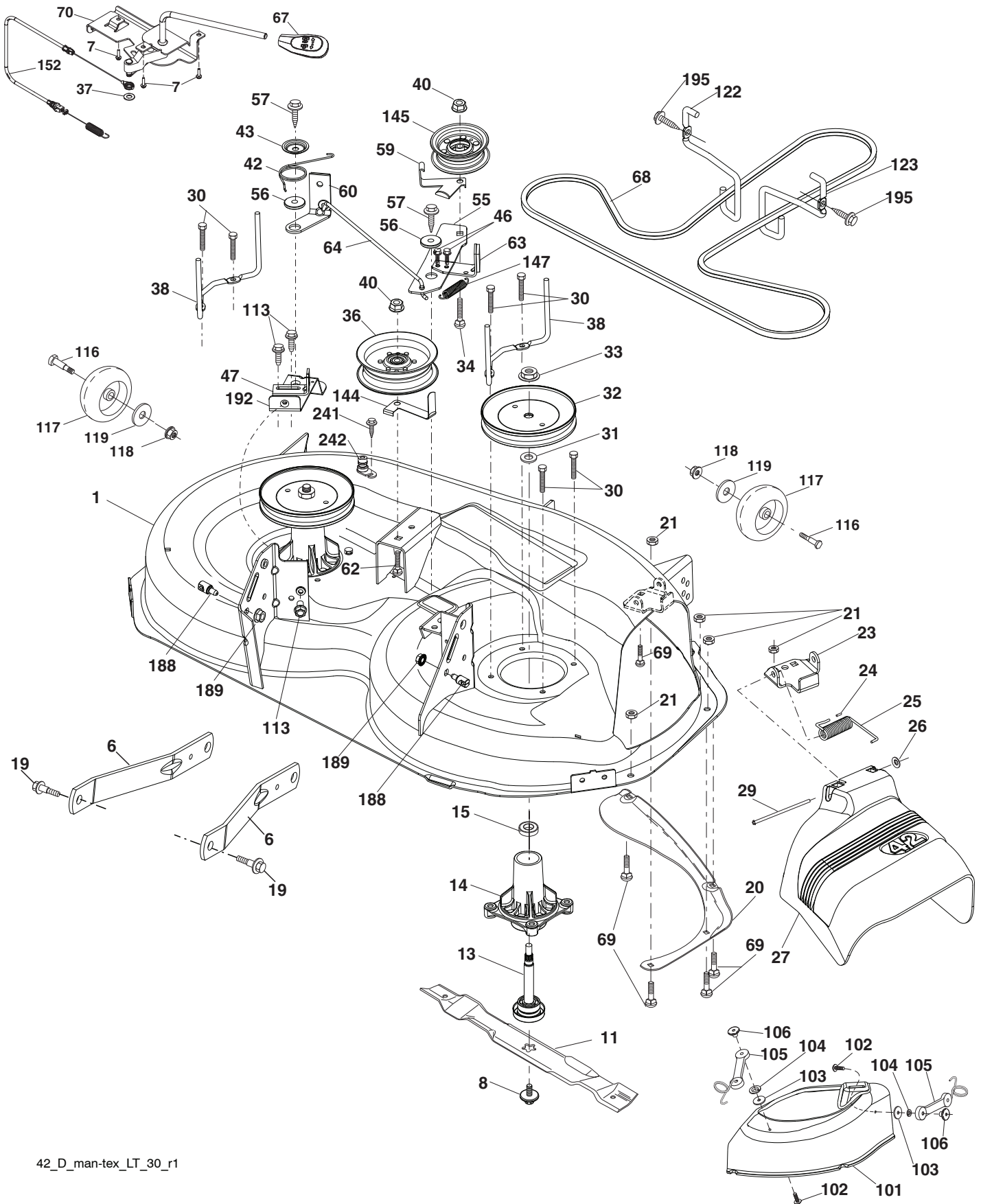

42\_D\_man-tex\_LT\_30\_r1

# TRACTOR - - MODEL NUMBER 944.600100

## MOWER DECK

KEY NO.	PART NO.	DESCRIPTION	KEY NO.	PART NO.	DESCRIPTION
1	199911	Deck Weldment Mower	59	141043	Guard, Tuv Idler
6	195186	Arm Suspension	60	197261	Arm Brake Mower
7	416358	Screw #10 x .750 BOS Thread	62	STD533720	Bolt Rd Hd Sq Nk 3/8-16 unc x 2
8	193003	Bolt/Washer asm 7/16-20 unf	63	199477	Arm Brake Mower
11	422719	Blade, 42"SP 3NI	64	199790	Link Brake Asm
--	424752	Blade, 42" 3NI	67	198398X428	Handle Clutch Cable
--	134149	Blade, Mulching	68	429636	V-Belt
--	139775	Blade, 42" Mulching Premium	69	STD533106	Bolt
--	138971	Blade, 42" Hi-Lift (For bagging or discharge)	70	401246	Clutch Asm Manual
13	192872	Shaft Assembly, Mandrel	101	193107	Cover Mulching.42"Black
14	187281	Housing, Mandrel	102	71081010	Screw Pan HD Phillip.10-24 x 5/8
15	110485X	Bearing, Ball, Mandrel	103	19061216	Washer #10
19	196539	Bolt, Shoulder	104	10071000	Washer Lock #10
20	159770	Baffle, Vortex	105	160793	Latch Asm Mulch/Bagger
21	STD541431	Nut, Crownlock 5/16-18 unc	106	2029J	Nut Weld .327/.304 #10-24
23	192557	Bracket, Deflector	113	17000510	Bolt 5/16-18 Hex
24	105304X	Cap, Sleeve	122	197258	Keeper Belt Engine LH
25	197026	Spring, Torsion, Deflector	123	197259	Keeper Belt Engine RH
26	110452X	Nut, Push	144	199204	Keeper Belt
27	424469	Shield, Deflector	145	193197	Pulley Idler, Flat
29	131491	Rod, Hinge	147	401971	Spring Return
30	173984	Screw Thdrol Rolling Wsh Hd	152	408714	Manual Clutch Cable
31	187690	Washer, Spacer	188	195161	Stud Fastener
32	197473	Pulley, Mandrel	189	73900500	Nut Lock Hex Flange
33	400234	Nut, Toplock, Flanged	192	197260	Bracket Brake Stand LH
34	72110612	Bolt Carr Sh. 3/8-16 x 1-1/2 Gr. 5	195	17000612	Screw Hex Wsh Thdr 3/8-16 x 3/4
36	197379	Pulley, Idler	241	152927	Screw TT #10-32.5. 3/8 Flange
37	STD551037	Washer	242	415598	Port Washout
38	199189	Keeper Belt LH Mandrel	--	416405	Coupling Quick Connect
40	73900600	Nut, Lock Flg. 3/8-16 unc	--	192870	Mandrel Assembly (Includes housing, shaft assembly, and bearing only - pulley/nut/washer and blade bolt/washers not included)
42	198410	Spring Torsion Brake	--	435238	Replacement Mower, Complete
43	197256	Spring Torsion Retainer			
46	137729	Screw Thd Roll 1/4-20 x 5/8			
47	197250	Bracket Clutch Cable			
55	197249	Arm, Idler			
56	199092	Spacer, Retainer			
57	17000616	Screw 3/8-16 x 1			

**NOTE:** All component dimensions given in U.S. inches  
1 inch = 25.4 mm

# TRACTOR - - MODEL NUMBER 944.600100

## MOWER LIFT

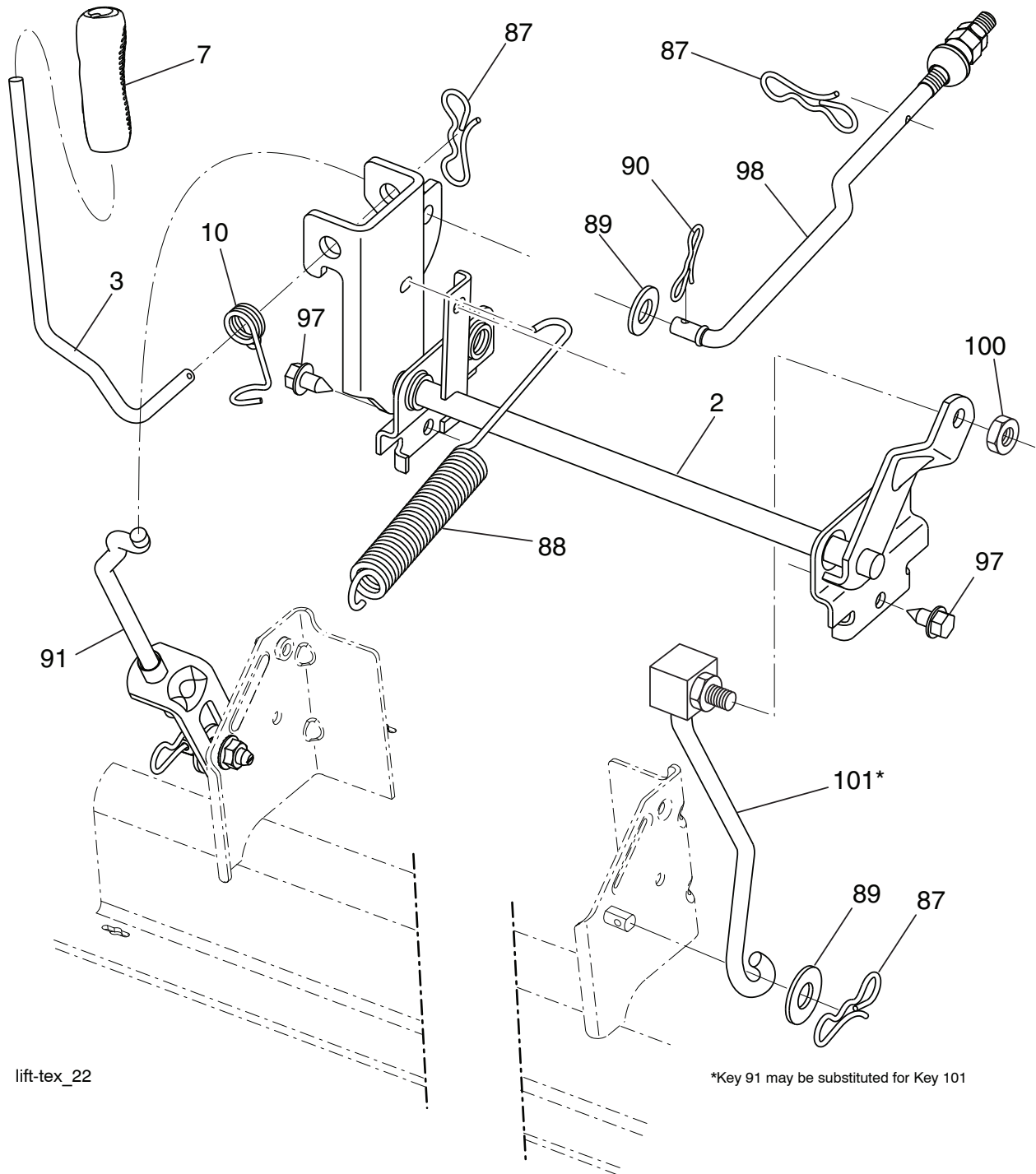

lift-tex\_22

\*Key 91 may be substituted for Key 101

# TRACTOR - - MODEL NUMBER 944.600100

## MOWER LIFT

KEY NO.	PART NO.	DESCRIPTION
2	422027	Shaft Asm., Lift
3	195231	Lever Asm., Lift RH
7	196492X428	Grip, Lever
10	196314	Spring Torsion
87	194209	Pin Cotter 7/16 Bow Tie Lock
88	410710	Spring Lift Assist
89	19191912	Washer Clear Zinc
90	194208	Pin Cotter 5/16 Bow Tie Lock
91	195181	Link Lift Susp Mower Rear
97	17000612	Screw 3/8-16 x .75
98	195270	Link Lift Susp. Front Mower
100	73930600	Nut Centerlock 3/8-16 unc
101	407003	Link Asm. Lift FXD

**NOTE:** All component dimensions given in U.S. inches  
1 inch = 25.4 mm

# TRACTOR - - MODEL NUMBER 944.600100

## SEAT ASSEMBLY

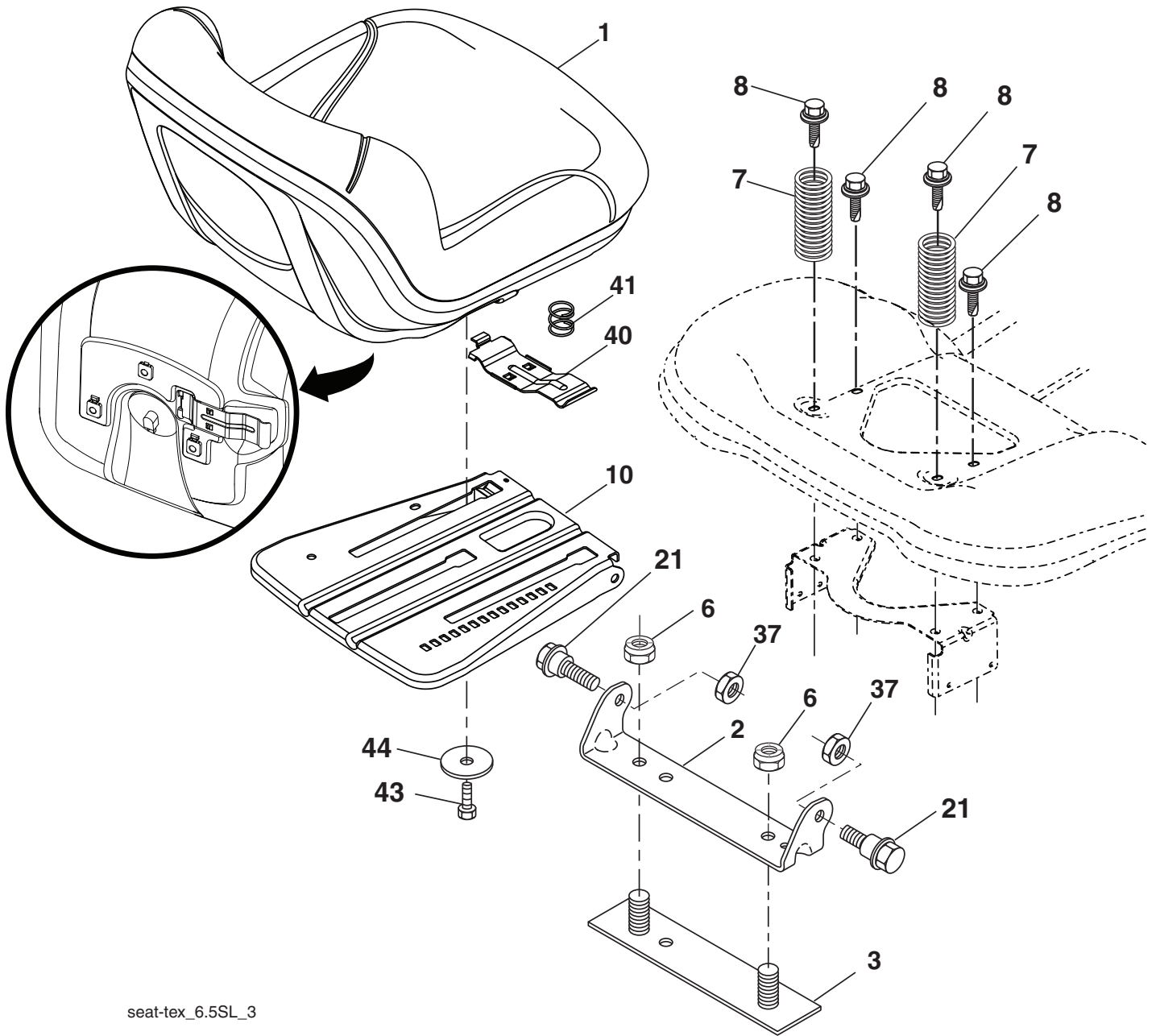

seat-tex\_6.5SL\_3

# TRACTOR - - MODEL NUMBER 944.600100

## SEAT ASSEMBLY

KEY NO.	PART NO.	DESCRIPTION
1	423644	Seat
2	180166	Bracket Pivot Fender
3	140675	Strap, Asm Fender
6	STD541437	Nut, Lock W/Ins. 3/8-16 unc
7	124181X	Spring, Seat Cprsn
8	171877	Bolt 5/16-18 uncx 3/4 w/Sems
10	196977	Pan, Seat
21	171852	Bolt, Shoulder 5/16-18
37	STD541431	Nut, Lock 5/16-18 unc
40	197661	Handle Slide Seat
41	198200	Spring Latch Seat
43	74760612	Bolt 3/8-16 x 3/4
44	19133812	Washer 13/32 x 2-3/8 x 12 Ga.

**NOTE:** All component dimensions given in U.S. inches  
1 inch = 25.4 mm

# REPAIR PARTS

## TRACTOR- -MODEL NO. 944.600100 TUFFTORQ TRANSAXLE - - MODEL NUMBER K46BA

MODEL K46BA  
7A646084100

ACTUAL PARTS  
MAY NOT APPEAR  
AS SHOWN

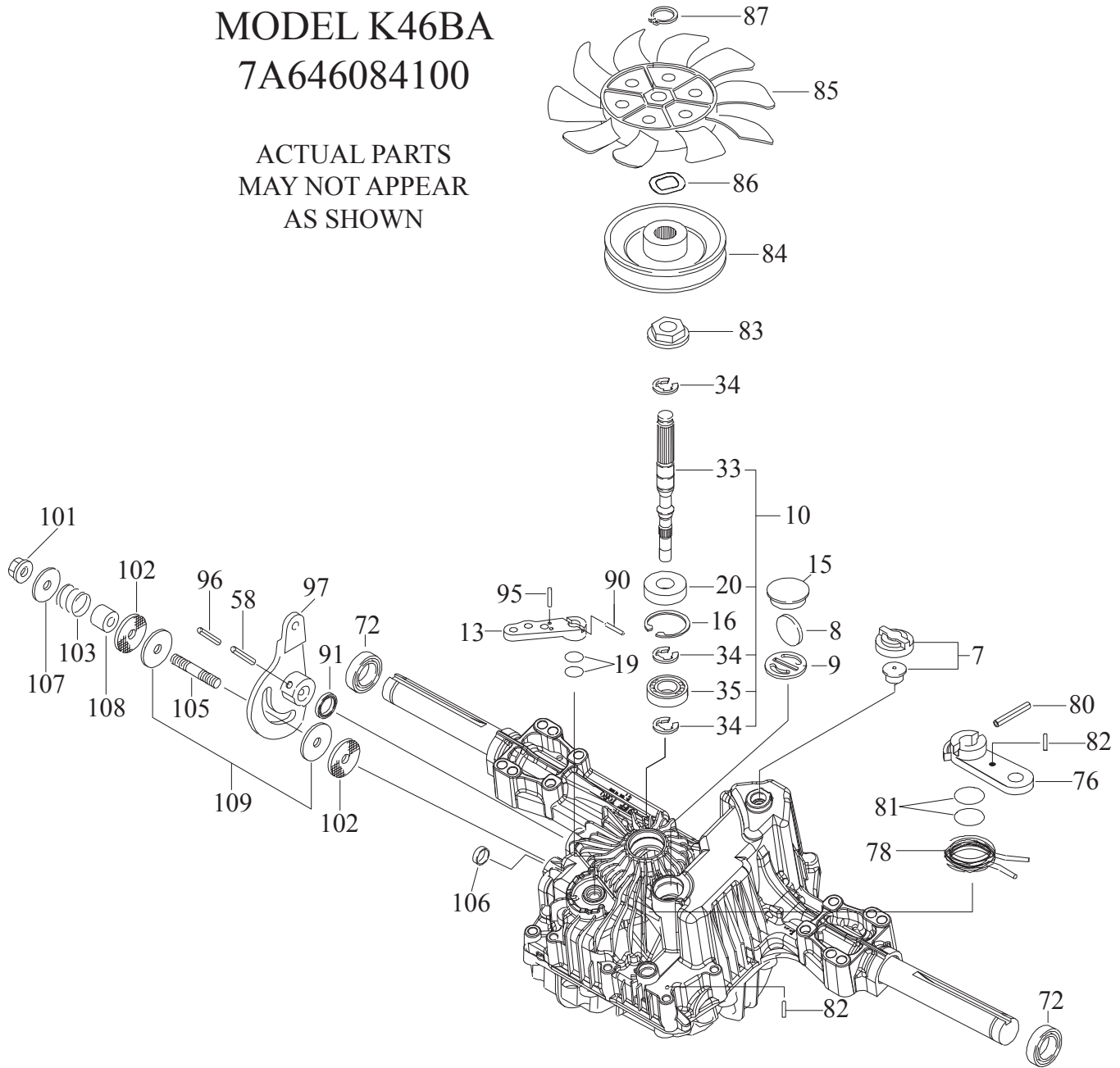



# REPAIR PARTS

## TRACTOR- -MODEL NO. 944.600100 TUFFTORQ TRANSAXLE - - MODEL NUMBER K46BA

KEY NO.	PART NO.	DESCRIPTION
7	414395	Vent Valve 15
8	414396	Magnet
9	414397	Magnet Holder
10	415923	Pump Shaft/Bearing Kit
13	414398	Bypass Lever
15	414399	Sealing Cap 30
16	414400	Snap Ring C 35
19	414401	O-Ring 1a P10a
20	414402	Seal Tc 153507
33	414403	Pump Shaft (Standard
34	414404	E-Ring 15
35	414405	Bearing 6202c3
58	414406	Roll Pin 6 * 40
72	414407	Seal 19 * 32 * 8
76	414408	Brake Lever
78	414409	Brake Return Spring
80	414410	Spring Pin 5 * 32
81	414411	O-Ring 1a P12
82	414412	Spring Pin 4 * 16
83	414413	Spine Collar
84	414414	Pulley L
85	414415	Fan, Black
86	414416	Wave Washer
87	414417	Snap Ring
90	414418	Spring Pin 3.0a * 20
91	414419	Oil Seal 16 * 22 * 03
95	415850	Spring Pin 3.0a * 16
96	414420	Roll Pin 3.5 * 40
97	414421	Control Lever
101	414216	Lock Nut 10
102	414423	Washer 10 * 40 * 4
103	414424	Spring
105	414425	Stud 10 * 60
106	414426	Sealing Cap 18
107	414427	Washer 10 * 36 * 2.8
108	414428	Collar 10 * 20 * 17
109	414429	Friction Plate Kit

**NOTE:** All component dimensions given in U.S. inches.  
1 inch = 25.4 mm

# TRACTOR - - MODEL NUMBER 944.600100

## BRIGGS ENGINE - MODEL NUMBER 31P677, TYPE NUMBER 0804-B1

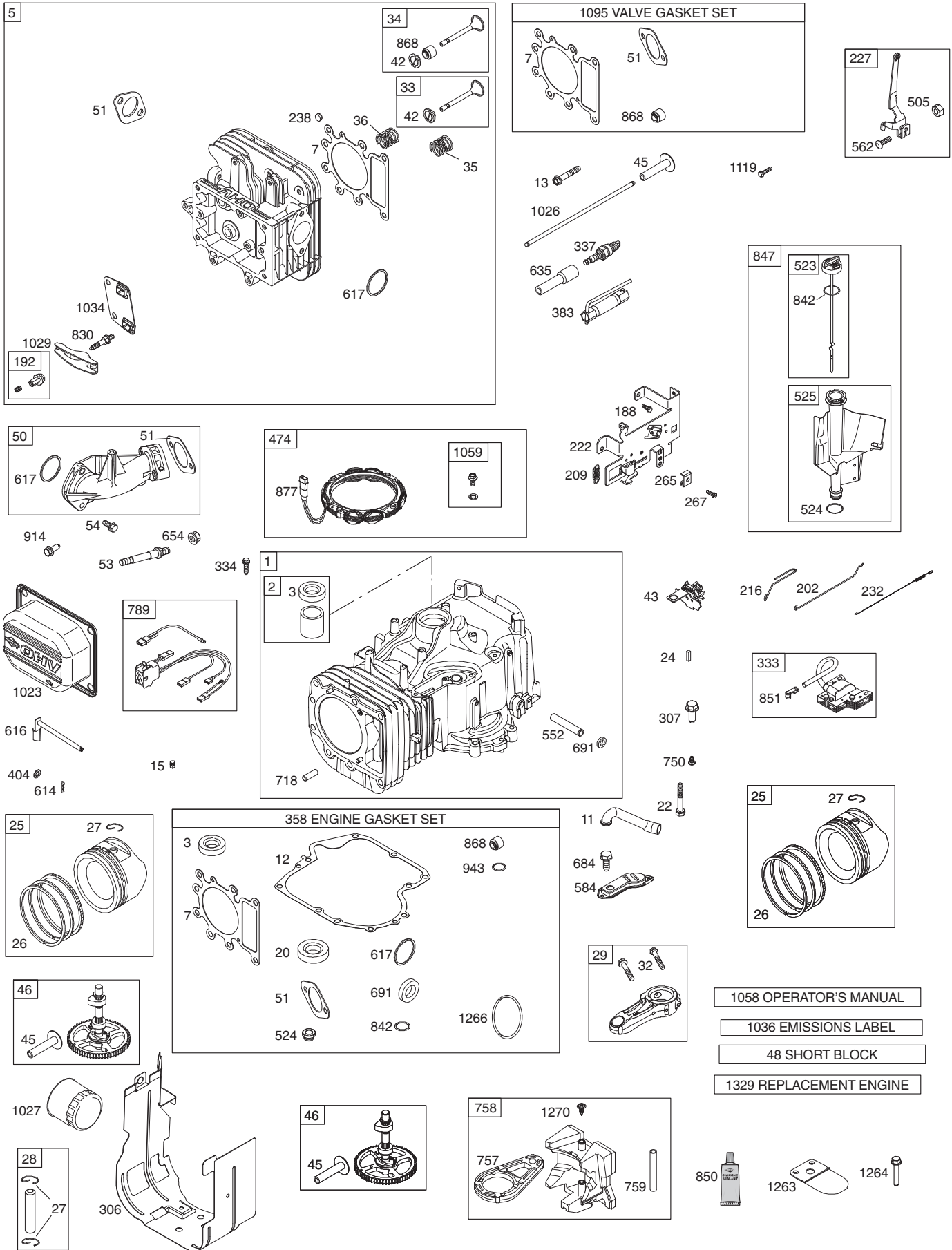

**TRACTOR - - MODEL NUMBER 944.600100**  
**BRIGGS ENGINE - MODEL NUMBER 31P677, TYPE NUMBER 0804-B1**

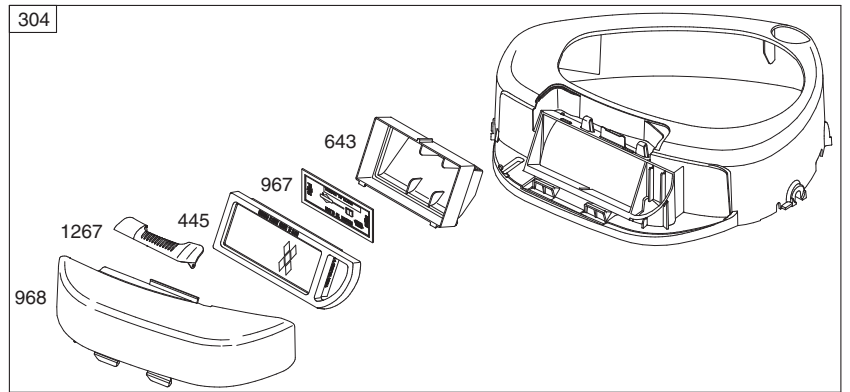
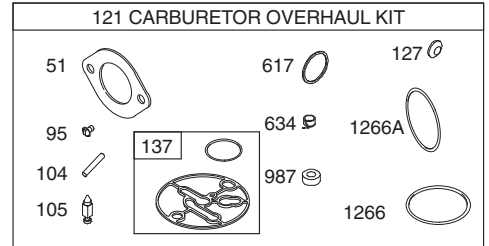
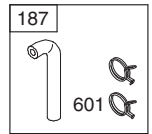
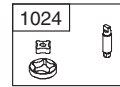
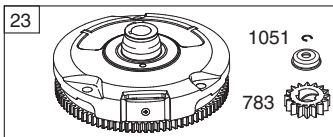
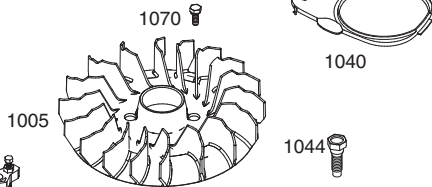
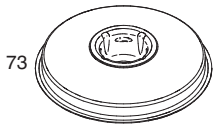
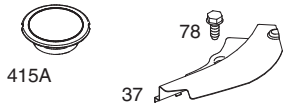
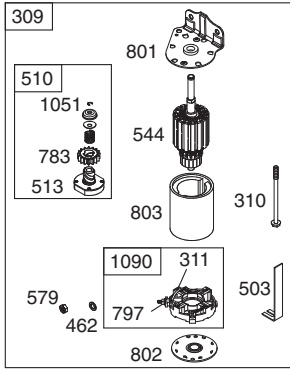
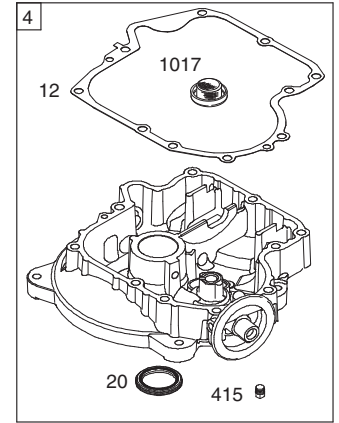
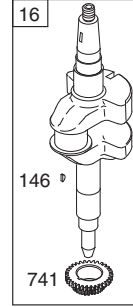
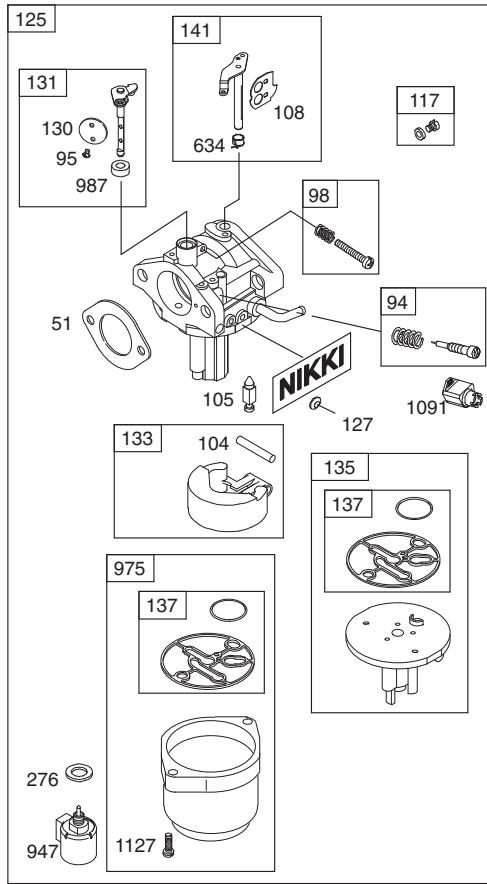
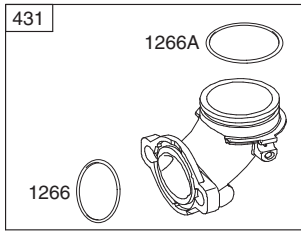

## TRACTOR - - MODEL NUMBER 944.600100

**BRIGGS ENGINE - MODEL NUMBER 31P677, TYPE NUMBER 0804-B1**

KEY NO.	PART NO.	DESCRIPTION	KEY NO.	PART NO.	DESCRIPTION
1	793987	Cylinder Assembly	117	792296	Jet-Main (Standard)
2	399265	Kit-Bushing/Seal (Magneto Side)	121	792369	Kit-Carburetor Overhaul
3	391086s	• Seal-Oil (Magneto Side)	125	792768	Carburetor
4	697188	Sump-Engine	127	690727	Ø Plug-Welch
5	793991	Head-Cylinder	130	792747	Valve-Throttle
7	699168	•+ Gasket-Cylinder Head	131	792765	Kit-Throttle Shaft
11	794683	Tube-Breather	133	694914	Float-Carburetor
12	697110	• Gasket-Crankcase	135	698780	Tube-Fuel Transfer
13	793988	Screw (Cylinder Head)	137	698781	Ø Gasket-Float Bowl
15	690946	Plug-Oil Drain	141	792777	Kit-Choke Shaft
16	697127	Crankshaft	146	691639	Key-Timing
20	690947	• Seal-Oil (PTO Side)	187	791805	Line-Fuel
22	692125	Screw (Crankcase Cover/Sump)	188	691693	Screw (Control Bracket)
23	693557	Flywheel	192	691986	Adjuster-Rocker Arm
24	222698s	Key-Flywheel	202	691841	Link-Mechanical Governor
25	792507	Piston Assembly (Standard)	209	692208	Spring-Governor
25	792648	Piston Assembly (.020" Oversize)	216	691840	Link-Choke
26	791936	Ring Set (Standard)	222	694042	Bracket-Control
26	792649	Ring Set (.020" Oversize)	227	691374	Lever-Governor Control
27	698469	Lock-Piston Pin	232	691842	Spring-Governor
28	697099	Pin-Piston	238	691843	Cap-Valve
29	794122	Rod-Connecting (Standard)	240	394358s	Filter-Fuel
32	791118	Screw (Connecting Rod)	265	691024	Clamp-Casing
33	791934	Valve-Exhaust	267	794904	Screw (Casing Clamp)
34	791935	Valve-Intake	276	695410	Ø Washer-Sealing
35	691279	Spring-Valve (Intake)	304	699829	Housing-Blower
36	691279	Spring-Valve (Exhaust)	305	697102	Screw (Blower Housing)
37	697352	Guard-Flywheel	305A	793376	Screw (Blower Housing)
42	499586	Retainer-Valve	306	697107	Shield-Cylinder
43	691968	Slinger-Governor/Oil	307	691003	Screw (Cylinder Shield)
45	690564	Tappet-Valve	309	693551	Motor-Starter
46	793880	Camshaft	310	690323	Bolt (Starter Motor)
48	697762	Short Block	311	497608	Brush Set
50	690193	Manifold-Intake	333	795315	Armature-Magneto
51	692137	•Ø+ Gasket-Intake	334	691061	Screw (Magneto Armature)
53	690227	Stud (Carburetor)	337	491055s	Plug-Spark
54	691148	Screw (Intake Manifold)	358	697191	Gasket Set-Engine
73	794437	Screen-Rotating	363	19203	Flywheel Puller
78	691003	Screw (Flywheel Guard)	383	89838s	Wrench-Spark Plug
94	695425	Kit-Idle Mixture	404	691691	Washer (Governor Crank)
95	690718	Ø Screw (Throttle Valve)	415	690283	Plug
98	695408	Kit-Idle Speed	415A	794129	Plug
104	694918	Ø Pin-Float Hinge	431	697122	Elbow-Intake
105	696136	Ø Valve-Float Needle	445	698083	Filter-Air Cleaner Cartridge
108	695419	Valve-Choke	462	691261	Washer (Starter Cable)

## TRACTOR - - MODEL NUMBER 944.600100

### BRIGGS ENGINE - MODEL NUMBER 31P677, TYPE NUMBER 0804-B1

KEY NO.	PART NO.	DESCRIPTION	KEY NO.	PART NO.	DESCRIPTION
474	696459	Alternator	877	393456	Wire/Connector-Alternator
503	691532	Strap-Starter	914	691108	Screw (Rocker Cover)
505	691251	Nut (Governor Control Lever)	943	690589	• Seal-O Ring (Oil Pump Cover)
510	693699	Drive-Starter	947	699915	Solenoid-Fuel
513	692024	Clutch-Drive	965	499613	Cover-Oil Pump
523	699908	Dipstick	967	697015	Filter-Pre Cleaner
524	691032	• Seal-Dipstick Tube	968	699986	Cover-Air Cleaner
525	697184	Tube-Dipstick	975	699502	Bowl-Float
544	692034	Starter-Armature	987	698777	Ø Seal-Throttle Shaft
552	697144	Bushing-Governor Crank	1005	794438	Fan-Flywheel
562	691119	Bolt (Governor Control Lever)	1017	690770	Screen-Oil Pump
579	691029	Nut (Starter Cable)	1023	791079	Cover-Rocker Arm
584	794682	Cover-Breather Passage	1024	794644	Pump-Oil
601	791850	Clamp-Hose	1026	692003	Rod-Push (Intake)
614	691620	Pin-Cotter		692011	Rod-Push (Exhaust)
616	692012	Crank-Governor	1027	492932s	Filter-Oil
617	692138	Ø • Seal-O Ring (Intake Manifold)	1029	691751	Arm-Rocker
634	698779	Ø Spring/Seal Assembly (Choke A Matic)	1034	690822	Guide-Push Rod
635	691909	Boot-Spark Plug	1036	791932	Label-Emissions
643	698401	Retainer-Air Filter	1040	699852	Plate-Trim
654	690958	Nut (Carburetor)	1044	698139	Screw (Flywheel)
684	697157	Screw (Breather Passage Cover)	1051	691265	Ring-Retaining
691	692407	• Seal-Governor Shaft	1058	275935	Owner's Manual
697	690372	Screw (Drive Cap)	1059	698516	Kit-Screw/Washer
718	690959	Pin-Locating	1070	690363	Screw (Flywheel Fan)
729	691224	Clip-Wire	1090	691293	Retainer-Brush
741	697128	Gear-Timing	1091	691333	Cap-Limiter
750	790832	Screw (Oil Pump Cover)	1095	690190	Gasket Set-Valve
757	793242	Link-Counterweight	1119	691183	Screw (Alternator)
758	697134	Counterweight	1127	695407	Screw (Float Bowl)
759	697392	Pin-Counterweight	1263	697124	Reed-Breather
783	693713	Gear-Pinion	1264	697104	Screw (Breather Reed)
789	698329	Harness-Wiring	1266	691917	•Ø Seal-O Ring (Intake Elbow)
797	693167	Nut (Brush Retainer)	1266A	697123	Ø Seal-O Ring (Intake Elbow)
801	691283	Cap-Drive	1267	697419	Latch-Blower Housing
802	691286	Cap-End	1270	793243	Plug-AVS Counterweight
803		Housing-Starter (For service order complete starter motor reference 309)	1329	331877-0036	Replacement Engine
830	691095	Stud (Rocker Arm)			• Included in Engine Gasket Set, Key. No. 358
842	691031	• Seal-O Ring (Dipstick Tube)	Ø		Included in Carburetor Overhaul Kit, Key. No. 121
847	790442	Dipstick/Tube Assembly	+		Included in Valve Gasket Set, Key. No. 1095
850	100100	Sealant-Liquid			
851	692424	Terminal-Spark Plug			
868	690968	•+ Seal-Valve			

**NOTE:** All component dimensions given in U.S. inches  
1 inch = 25.4 mm

**GENERAL:** Craftsman products are warranted to be free from defects in materials or workmanship for a specific time period as set-out below (the "Warranty Period"). Warranties extend to the original purchaser of a Craftsman product only. Purchases made through an online auction or through any website other than www.sears.ca are excluded. The relevant Warranty Period commences on the original date of purchase. Within this period, SEARS CANADA, Inc. will, at its sole option, repair or replace any products or components which fail in normal use. Such repairs or replacement will be made at no charge to the customer for parts or labor, provided that the customer shall be responsible for any transportation cost.

**EXCLUSIONS:** This warranty does not cover failures due to normal wear, abuse, misuse, neglect (including but not limited to the use of stale fuel, dirt, abrasives, moisture, rust, corrosion, or any adverse reaction due to improper storage or use habits), improper maintenance or failure to follow maintenance guidelines and/or instructions, failure to operate the product in accordance with the owner's manual or any additional instructions or information provided at the time of purchase or in subsequent communications with the original purchaser, accident or unauthorized alterations or repairs made or attempted by others. Also excluded from warranty coverage - except as provided below - are the following: maintenance, adjustments, components subject to wear including but not limited to: cosmetic components, belts, blades, blade adapters, bulbs, tires, filters, guide bars, lubricants, seats, grips, recoil assy's, saw chains and bars, trimmer lines and spools, spark plugs, starter ropes and tines, and discoloration resulting from ultraviolet light. Any product missing the model and/or serial number identification label will be disqualified from coverage under this warranty.

**REPAIRS:** Repairs have a 90 day warranty. If the defective product is still within the Warranty Period, then the new warranty is 90 days from the date of repair or to the end of the original Warranty Period, whichever period is longer.

**DISCLAIMERS:** THE WARRANTIES AND REMEDIES CONTAINED HEREIN ARE EXCLUSIVE AND IN LIEU OF ALL OTHER WARRANTIES, WHETHER ORAL OR WRITTEN (OTHER THAN AS STATED HEREIN), AND WHETHER EXPRESS, IMPLIED OR STATUTORY, INCLUDING BUT NOT LIMITED TO ANY. THIS WARRANTY GIVES YOU SPECIFIC LEGAL RIGHTS, WHICH MAY VARY FROM PROVINCE TO PROVINCE.

IN NO EVENT SHALL SEARS BE LIABLE FOR ANY INCIDENTAL, SPECIAL, INDIRECT OR CONSEQUENTIAL DAMAGES, WHETHER RESULTING FROM THE USE, MISUSE OR INABILITY TO USE THE PRODUCT OR FROM DEFECTS IN THE PRODUCT. THE EXCLUSIONS IN THIS PARAGRAPH SHALL NOT APPLY IN JURISDICTIONS WHERE APPLICABLE LAW DOES NOT ALLOW FOR THE EXCLUSION OF INCIDENTAL OR CONSEQUENTIAL DAMAGES. IN SUCH JURISDICTIONS, THIS PARAGRAPH SHALL NOT APPLY, BUT THE REMAINING PROVISIONS OF THIS DOCUMENT SHALL REMAIN VALID.

SEARS retains the exclusive right to repair or replace the product or offer a full refund of the purchase price at its sole discretion. SUCH REMEDY SHALL BE YOUR SOLE AND EXCLUSIVE REMEDY FOR ANY BREACH OF WARRANTY.

**CUSTOMER RESPONSIBILITIES:** In addition to complying with all suggested maintenance guidelines and instructions, customers' obligations shall include but shall not be limited to: operating the product in accordance with the owner's manual or any additional instructions or information provided at the time of purchase or in subsequent communications to the purchaser from time to time, exhibit reasonable care in the use, operation, maintenance, general upkeep and storage of the product. Failure to comply with these requirements will void any applicable warranty.

**LIST OF APPLICABLE WARRANTY PERIODS:** The following list contains the applicable Warranty Period for your Craftsman product and is based on a combination of the type of product or component and the intended and actual use of the product or component:

1. **90 DAYS:** Craftsman products intended for use or actually used for commercial, institutional, professional or income-producing purposes
2. **2 YEARS:** Craftsman riding lawn mowers, yard and garden tractors, walk behind mowers, tillers, brush cutters, snow blowers, handheld blowers, backpack blowers, hedge trimmers and electrical products for noncommercial, nonprofessional, non-institutional, or non-income-producing use, except for those components which are part of engine systems manufactured by third party engine manufacturers for which the purchase has received an separate warranty with product information supplied at the time of purchase.
3. **1 YEAR:** Craftsman power cutters, stump grinders, pole pruners, gas chain saws, electric chain saws, trimmer attachments, baggers and pole saws for noncommercial, nonprofessional, non-institutional, or non-income-producing use.
4. **90 DAYS:** All defective batteries, which will be replaced during this 90-day Warranty Period.
5. **60 DAYS:** Additional Warranty Period of 60 days will apply to adjustments and worn products or components BUT DOES NOT INCLUDE WEAR OR ADJUSTMENTS for products used for commercial, institutional, professional or income-producing purposes. Wear items include but are not limited to: belts, blades, tires, spark plugs, air filters, chains, shear bolts, skid plates, scraper bars, drift cutters, ropes, tines, collection bags and pulleys.

As the Warranty Period runs from the date of purchase and NOT from the date that a product is delivered, opened, assembled or first used, please ensure during this time period that your product or component has been assembled and tested for correction operation regardless of when you intend to actually use it. Claims made after the Warranty Period has expired will not be honored.

**PROOF OF PURCHASE/DOCUMENTATION:** Warranty coverage is conditioned upon the original purchaser furnishing SEARS CANADA or its authorized third party service provider if applicable, with the original sales receipt or other adequate written proof of the original purchase date and identification of the product. In the event that the original purchaser is unable to provide a company of the original sales receipt, SEARS CANADA Inc. reserves the right to determine in its sole discretion what other written proof of the original purchase date and identification of the product is acceptable.

# SUGGESTED GUIDE FOR SIGHTING SLOPES FOR SAFE OPERATION

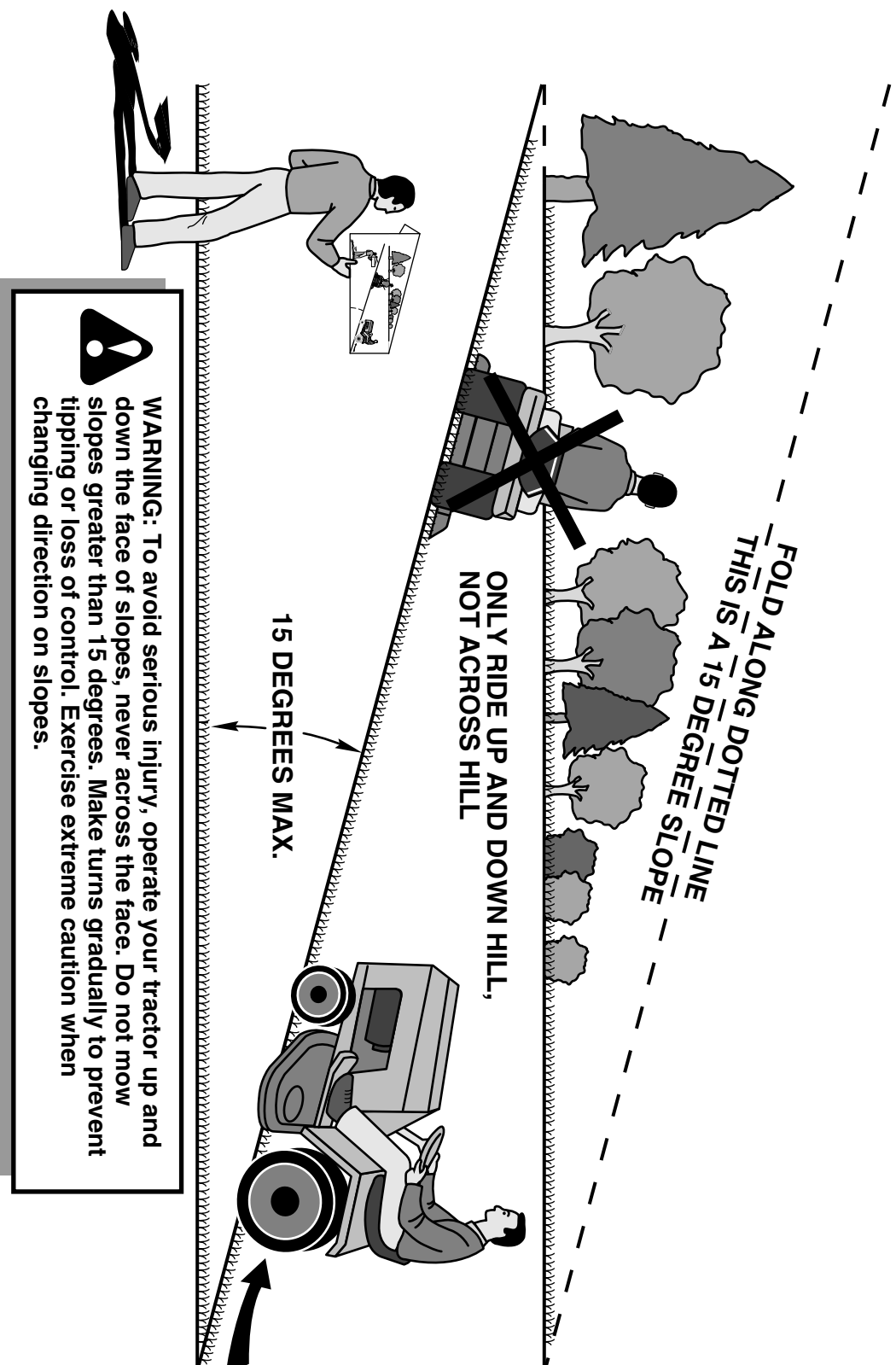

# Get it fixed, at your home or ours!

Just Call:

**1-800-4-MY-HOME<sup>®</sup>**

(1-800-469-4663)

24 hours a day, 7 days a week

For the repair of major brand appliances **in your own home...**  
no matter who made it, no matter who sold it!

For your nearest **Sears Parts and Service** location,  
to bring in products like vacuums, lawn equipment and electronics.

For **Sears Parts & Service**, to order the replacement parts,  
accessories and owner's manuals that you need to do-it-yourself.

[www.sears.ca](http://www.sears.ca)

---

To purchase or inquire about a Sears Maintenance Agreement, call:

**1-800-361-6665**

9 a.m. – 11 p.m. Mon. – Fri., EST, 9 a.m. – 4 p.m. Sat.

---

Pour service en français:

**1-800-LE-FOYER<sup>MC</sup>**

(1-800-533-6937)

[www.sears.ca](http://www.sears.ca)



® / ™ Trademarks of Sears, Roebuck and Co. used under license by Sears Canada

<sup>MD</sup> Marque déposée / <sup>MC</sup> Marque de commerce de Sears, Roebuck and Co. utilisée en vertu d'une licence de Sears Canada