

SEARS
OWNER'S
MANUAL

MODEL NO.
944.600952

Caution:
Read and follow
all Safety Rules
and Instructions
Before Operating
This Equipment

EZ³

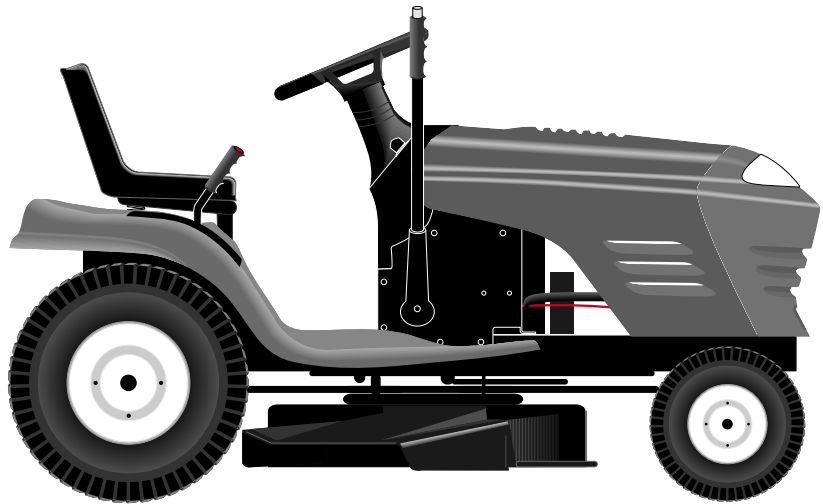

CRAFTSMAN[®]

**17.5 HP
ELECTRIC START
42" MOWER
AUTOMATIC
LAWN TRACTOR**

- Assembly
- Operation
- Customer Responsibilities
- Service and Adjustments
- Repair Parts



SAFETY RULES



Safe Operation Practices for Ride-On Mowers

IMPORTANT: THIS CUTTING MACHINE IS CAPABLE OF AMPUTATING HANDS AND FEET AND THROWING OBJECTS. FAILURE TO OBSERVE THE FOLLOWING SAFETY INSTRUCTIONS COULD RESULT IN SERIOUS INJURY OR DEATH.

I. GENERAL OPERATION

- Read, understand, and follow all instructions in the manual and on the machine before starting.
- Only allow responsible adults, who are familiar with the instructions, to operate the machine.
- Clear the area of objects such as rocks, toys, wire, etc., which could be picked up and thrown by the blade.
- Be sure the area is clear of other people before mowing. Stop machine if anyone enters the area.
- Never carry passengers.
- Do not mow in reverse unless absolutely necessary. Always look down and behind before and while backing.
- Be aware of the mower discharge direction and do not point it at anyone. Do not operate the mower without either the entire grass catcher or the guard in place.
- Slow down before turning.
- Never leave a running machine unattended. Always turn off blades, set parking brake, stop engine, and remove keys before dismounting.
- Turn off blades when not mowing.
- Stop engine before removing grass catcher or unclogging chute.
- Mow only in daylight or good artificial light.
- Do not operate the machine while under the influence of alcohol or drugs.
- Watch for traffic when operating near or crossing roadways.
- Use extra care when loading or unloading the machine into a trailer or truck.
- Data indicates that operators, age 60 years and above, are involved in a large percentage of riding mower-related injuries. These operators should evaluate their ability to operate the riding mower safely enough to protect themselves and others from serious injury.
- Keep machine free of grass, leaves or other debris build-up which can touch hot exhaust / engine parts and burn. Do not allow the mower deck to plow leaves or other debris which can cause build-up to occur. Clean any oil or fuel spillage before operating or storing the machine. Allow machine to cool before storage.

II. SLOPE OPERATION

Slopes are a major factor related to loss-of-control and tipover accidents, which can result in severe injury or death. All slopes require extra caution. If you cannot back up the slope or if you feel uneasy on it, do not mow it.

DO:

- Mow up and down slopes, not across.
- Remove obstacles such as rocks, tree limbs, etc.
- Watch for holes, ruts, or bumps. Uneven terrain could overturn the machine. *Tall grass can hide obstacles.*
- Use slow speed. Choose a low gear so that you will not have to stop or shift while on the slope.
- Follow the manufacturer's recommendations for wheel weights or counterweights to improve stability.
- Use extra care with grass catchers or other attachments. These can change the stability of the machine.
- Keep all movement on the slopes *slow* and *gradual*. Do not make sudden changes in speed or direction.
- Avoid starting or stopping on a slope. If tires lose traction, disengage the blades and proceed slowly *straight* down the slope.

DO NOT:

- *Do not* turn on slopes unless necessary, and then, turn slowly and gradually downhill, if possible.
- *Do not* mow near drop-offs, ditches, or embankments. The mower could suddenly turn over if a wheel is over the edge of a cliff or ditch, or if an edge caves in.
- *Do not* mow on wet grass. Reduced traction could cause sliding.
- *Do not* try to stabilize the machine by putting your foot on the ground.
- *Do not* use grass catcher on steep slopes.

III. CHILDREN

Tragic accidents can occur if the operator is not alert to the presence of children. Children are often attracted to the machine and the mowing activity. *Never* assume that children will remain where you last saw them.

- Keep children out of the mowing area and under the watchful care of another responsible adult.
- Be alert and turn machine off if children enter the area.
- Before and when backing, look behind and *down* for small children.
- Never carry children. They may fall off and be seriously injured or interfere with safe machine operation.
- Never allow children to operate the machine.
- Use extra care when approaching blind corners, shrubs, trees, or other objects that may obscure vision.

IV. SERVICE

- Use extra care in handling gasoline and other fuels. They are flammable and vapors are explosive.
 - Use only an approved container.
 - Never remove gas cap or add fuel with the engine running. Allow engine to cool before refueling. Do not smoke.
 - Never refuel the machine indoors.
 - Never store the machine or fuel container inside where there is an open flame, such as a water heater.
- Never run a machine inside a closed area.
- Keep nuts and bolts, especially blade attachment bolts, tight and keep equipment in good condition.
- Never tamper with safety devices. Check their proper operation regularly.
- Keep machine free of grass, leaves, or other debris build-up. Clean oil or fuel spillage. Allow machine to cool before storing.
- Stop and inspect the equipment if you strike an object. Repair, if necessary, before restarting.
- Never make adjustments or repairs with the engine running.
- Grass catcher components are subject to wear, damage, and deterioration, which could expose moving parts or allow objects to be thrown. Frequently check components and replace with manufacturer's recommended parts, when necessary.
- Mower blades are sharp and can cut. Wrap the blade(s) or wear gloves, and use extra caution when servicing them.
- Check brake operation frequently. Adjust and service as required.

SAFETY RULES

⚠ Safe Operation Practices for Ride-On Mowers ⚠

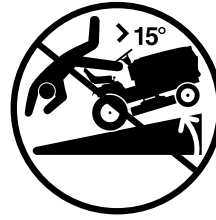

- Be sure the area is clear of other people before mowing. Stop machine if anyone enters the area.
- Never carry passengers or children even with the blades off.
- Do not mow in reverse unless absolutely necessary. Always look down and behind before and while backing.
- Never carry children. They may fall off and be seriously injured or interfere with safe machine operation.
- Keep children out of the mowing area and under the watchful care of another responsible adult.
- Be alert and turn machine off if children enter the area.
- Before and when backing, look behind and down for small children.
- Mow up and down slopes (15° Max), not across.
- Remove obstacles such as rocks, tree limbs, etc.
- Watch for holes, ruts, or bumps. Uneven terrain could overturn the machine. Tall grass can hide obstacles.
- Use slow speed. Choose a low gear so that you will not have to stop or shift while on the slope.
- Avoid starting or stopping on a slope. If tires lose traction, disengage the blades and proceed slowly straight down the slope.
- If machine stops while going uphill, disengage blades, shift into reverse and back down slowly.
- Do not turn on slopes unless necessary, and then, turn slowly and gradually downhill, if possible.

 Look for this symbol to point out important safety precautions. It means **CAUTION!!! BECOME ALERT!!! YOUR SAFETY IS INVOLVED.**

 **CAUTION:** Do not coast down a hill in neutral, you may lose control of the tractor.

 **CAUTION:** Tow only the attachments that are recommended by and comply with specifications of the manufacturer of your tractor. Use common sense when towing. Operate only at the lowest possible speed when on a slope. Too heavy of a load, while on a slope, is dangerous. Tires can lose traction with the ground and cause you to lose control of your tractor.

 **CAUTION:** In order to prevent accidental starting when setting up, transporting, adjusting or making repairs, always disconnect spark plug wire and place wire where it cannot contact spark plug.

TABLE OF CONTENTS

SAFETY RULES	2-3
PRODUCT SPECIFICATIONS	4
WARRANTY	4
CUSTOMER RESPONSIBILITIES	4, 15-18
ASSEMBLY	6-8
OPERATION	9-14

MAINTENANCE SCHEDULE	15
SERVICE AND ADJUSTMENTS	19-23
STORAGE	24
TROUBLESHOOTING	25-26
REPAIR PARTS - TRACTOR	28-45
REPAIR PARTS - ENGINE	46-53
PARTS ORDERING/SERVICE	BACK COVER

PRODUCT SPECIFICATIONS

GASOLINE CAPACITY AND TYPE:	1.25 GALLONS UNLEADED REGULAR
OIL TYPE (API-SF-SJ):	SAE 10W30 (above 32°F) SAE 5W-30 (below 32°F)
OIL CAPACITY:	4.5 PINTS
SPARK PLUG: (GAP: .030")	Champion RC12YC
GROUND SPEED (MPH):	FORWARD: 5.5 REVERSE: 2.4
TIRE PRESSURE:	FRONT: 14 PSI REAR: 10 PSI
CHARGING SYSTEM:	15 AMPS @ 3600 RPM
BATTERY:	AMP/HR: 30 MIN. CCA: 240 CASE SIZE: U1R
BLADE BOLT TORQUE:	27-35 FT. LBS.

CONGRATULATIONS on your purchase of a new tractor. It has been designed, engineered and manufactured to give you the best possible dependability and performance.

Should you experience any problem you cannot easily remedy, please contact your nearest authorized service center/department. We have competent, well-trained technicians and the proper tools to service or repair this tractor.

Please read and retain this manual. The instructions will enable you to assemble and maintain your tractor properly. Always observe the "SAFETY RULES".

MAINTENANCE AGREEMENT

A Maintenance Agreement is available on this product. Contact your nearest Sears store for details.

CUSTOMER RESPONSIBILITIES

- Read and observe the safety rules.
- Follow a regular schedule in maintaining, caring for and using your tractor.
- Follow the instructions under "Customer Responsibilities" and "Storage" sections of this owner's manual.

WARNING: This tractor is equipped with an internal combustion engine and should not be used on or near any unimproved forest-covered, brush-covered or grass-covered land unless the engine's exhaust system is equipped with a spark arrester meeting applicable local or state laws (if any). If a spark arrester is used, it should be maintained in effective working order by the operator.

A spark arrester for the muffler is available through your nearest authorized service center/department (See REPAIR PARTS section of this manual).

WARRANTY

LIMITED TWO (2) YEAR WARRANTY ON CRAFTSMAN TRACTOR (RIDING EQUIPMENT)

For two (2) years from date of purchase Sears Canada, Inc. will repair or replace at Sears option free of charge parts which are defective as a result of material or workmanship.

FULL ONE (1) YEAR WARRANTY ON BATTERY

For one (1) year from date of purchase, if any battery included with this riding equipment proves defective in material or workmanship and our testing determines the battery will not hold a charge, Sears will replace the battery at no charge.

COMMERCIAL OR RENTAL USE

Warranty on Riding Equipment used for commercial or rental purposes is limited to ninety (90) days.

This Warranty does **NOT** cover:

1. Pre-delivery set-up.
2. Tire replacement or repair caused by punctures from outside objects (such as nails, thorns, stumps, or glass).
3. Expendable items which become worn during normal use, such as blades, spark plug, air cleaners and belts.
4. Repairs necessary because of operator abuse or negligence, including damaged jackshaft or mandrel and the failure to operate and maintain the equipment according to the instructions contained in the Owner's Manual.
5. In Home service.

Warranty service is available by returning the Craftsman Riding Equipment to the nearest Sears Service Centre/Department in Canada. This warranty applies only while this product is in use in Canada.

This warranty is in addition to any statutory warranty and does not exclude or limit legal rights you may have but shall run concurrently with applicable provincial legislation. Furthermore, some provinces do NOT allow limitation on how long an implied warranty will last so the above limitations may not apply to you.

SEARS CANADA, INC., TORONTO, ONTARIO M5B 2B8

UNASSEMBLED PARTS

Steering Wheel

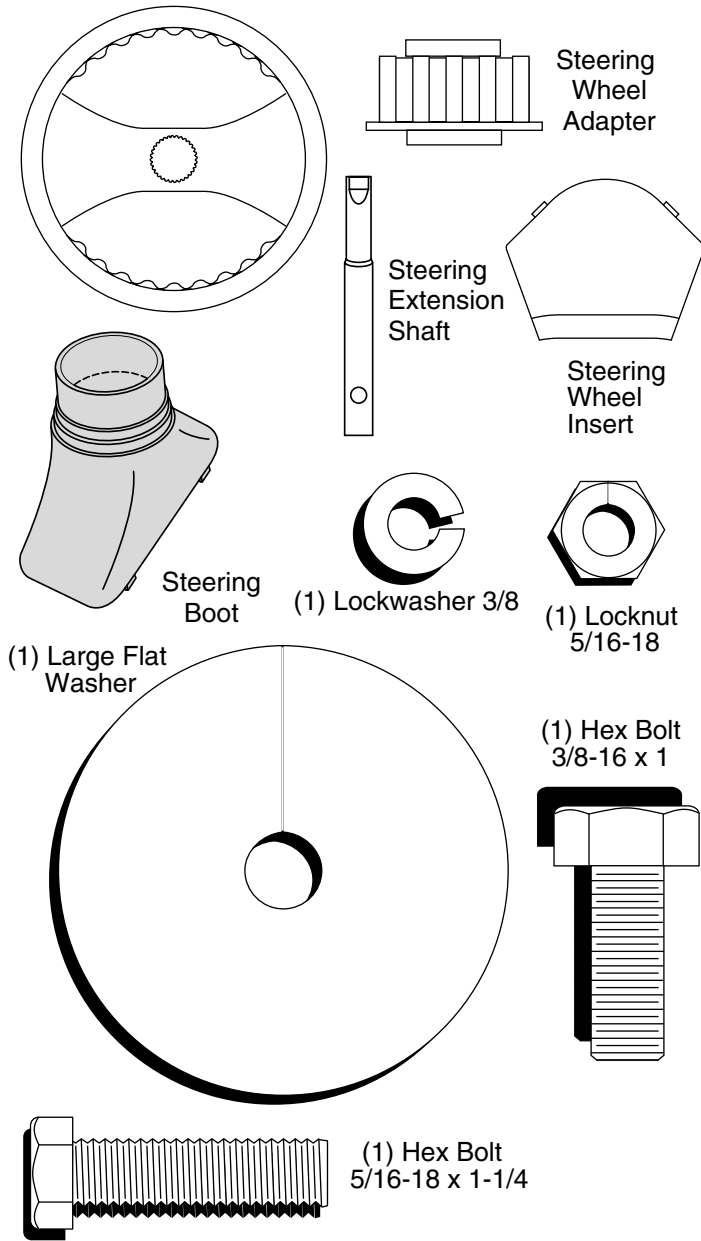

Seat

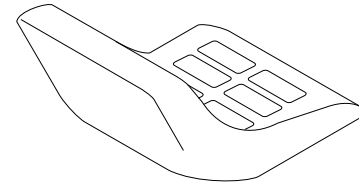

(1) Washer 17/32 x 1-3/16 x 12 Gauge

(1) Knob 

Battery

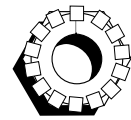
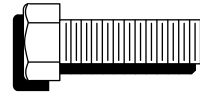

(2) Hex Bolts 1/4-20 x 3/4 (2) Keps Nuts 1/4-20

Keys

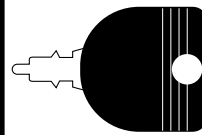

(2) Keys

Slope Sheet

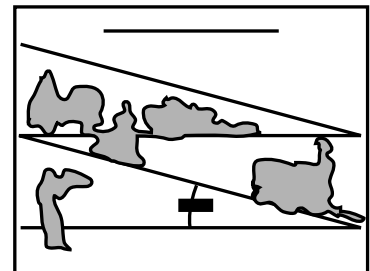

(1) Oil Drain Tube 

ASSEMBLY

Your new tractor has been assembled at the factory with exception of those parts left unassembled for shipping purposes. To ensure safe and proper operation of your tractor all parts and hardware you assemble must be tightened securely. Use the correct tools as necessary to insure proper tightness.

TOOLS REQUIRED FOR ASSEMBLY

A socket wrench set will make assembly easier. Standard wrench sizes are listed.

- | | |
|--------------------|---------------------|
| (1) 9/16" wrench | Pliers |
| (2) 7/16" wrenches | Tire pressure gauge |
| (2) 1/2" wrenches | Utility knife |

When right or left hand is mentioned in this manual, it means when you are in the operating position (seated behind the steering wheel).

TO REMOVE TRACTOR FROM CARTON

UNPACK CARTON

- Remove all accessible loose parts and parts cartons from carton.
- Cut, from top to bottom, along lines on all four corners of carton, and lay panels flat.
- Check for any additional loose parts or cartons and remove.

BEFORE REMOVING TRACTOR FROM SKID

ATTACH STEERING WHEEL (See Fig. 1)

ASSEMBLE EXTENSION SHAFT AND BOOT

- Slide extension shaft onto lower steering shaft. Align mounting holes in extension and lower shafts and install 5/16 hex bolt and locknut. Tighten securely.

IMPORTANT: TIGHTEN BOLT AND NUT SECURELY TO 18-22 FT. LBS TORQUE.

- Place tabs of steering boot over tab slots in dash and push down to secure.

INSTALL STEERING WHEEL

- Position front wheels of the tractor so they are pointing straight forward.
- Remove steering wheel adapter from steering wheel and slide adapter onto steering shaft extension.
- Position steering wheel so cross bars are horizontal (left to right) and slide inside boot and onto adapter.
- Assemble large flat washer, 3/8 lock washer, 3/8 hex bolt and tighten securely.
- Snap steering wheel insert into center of steering wheel.
- Remove protective materials from tractor hood and grill.

IMPORTANT: CHECK FOR AND REMOVE ANY STAPLES IN SKID THAT MAY PUNCTURE TIRES WHERE TRACTOR IS TO ROLL OFF SKID.

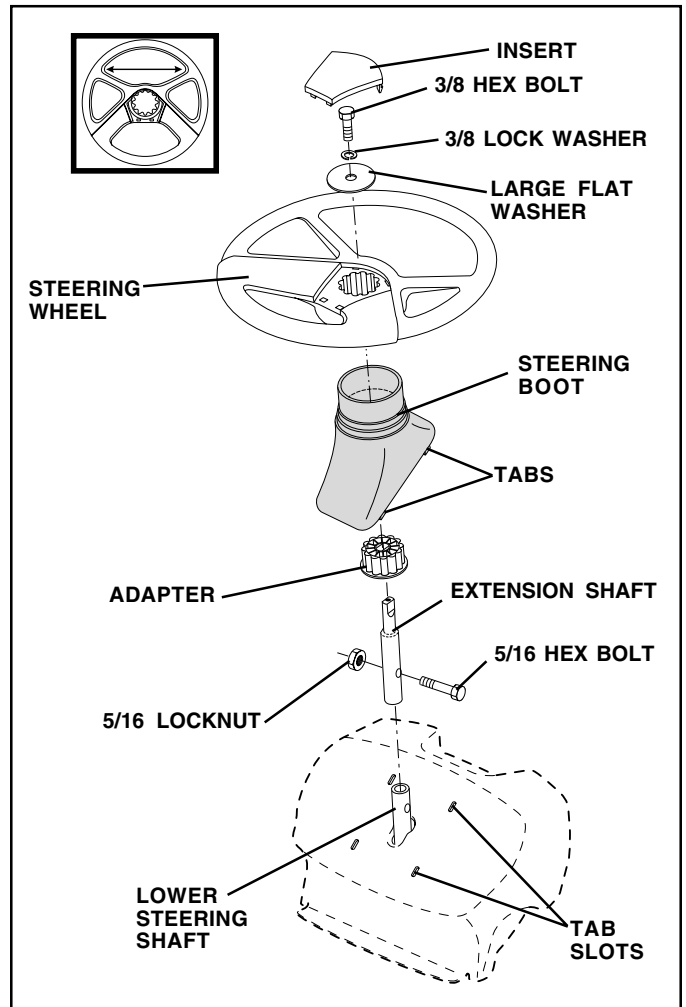

FIG. 1

HOW TO SET UP YOUR TRACTOR

CONNECT BATTERY (See Figs. 2 and 3)



CAUTION: Do not short battery terminals by allowing a wrench or any other object to contact both terminals at the same time. Before connecting battery, remove metal bracelets, wristwatch bands, rings, etc.

Positive terminal must be connected first to prevent sparking from accidental grounding.

- Remove cardboard packing from seat pan and lift seat pan to raised position.
- Open battery box door and remove protective plastic.
- Remove terminal protective caps and discard.
- If this battery is put into service after month and year indicated on label (label located between terminals) charge battery for minimum of one hour at 6-10 amps.

ASSEMBLY

- First connect RED battery cable to positive (+) terminal with hex bolt and keps nut as shown. Tighten securely.
- Connect BLACK grounding cable to negative (-) terminal with remaining hex bolt and keps nut. Tighten securely.
- Close battery box door.

Open battery box door for:

- Inspection for secure connections (to tighten hardware).
- Inspection for corrosion.
- Testing battery.
- Jumping (if required).
- Periodic charging .

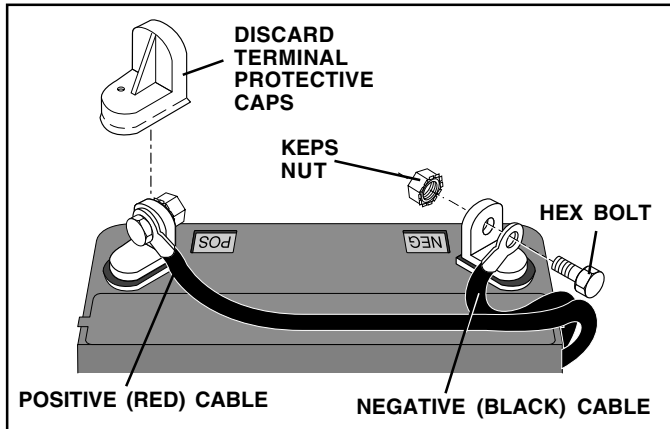

FIG. 2

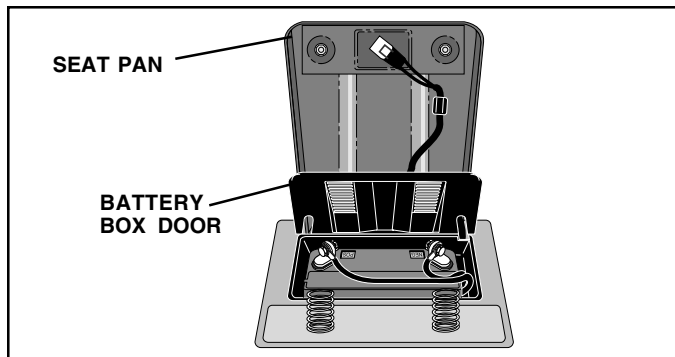

FIG. 3

INSTALL SEAT (See Fig. 4)

Adjust seat before tightening adjustment knob.

- Remove adjustment knob and flat washer securing seat to cardboard packing and set aside for assembly of seat to tractor.
- Pivot seat upward and remove from the cardboard packing. Remove the cardboard packing and discard.
- Place seat on seat pan so head of shoulder bolt is positioned over large slotted hole in pan.
- Push down on seat to engage shoulder bolt in slot and pull seat towards rear of tractor.
- Pivot seat and pan forward and assemble adjustment knob and flat washer loosely. Do not tighten.
- Lower seat into operating position and sit on seat.
- Slide seat until a comfortable position is reached which allows you to press clutch/brake pedal all the way down.
- Get off seat without moving its adjusted position.
- Raise seat and tighten adjustment knob securely.

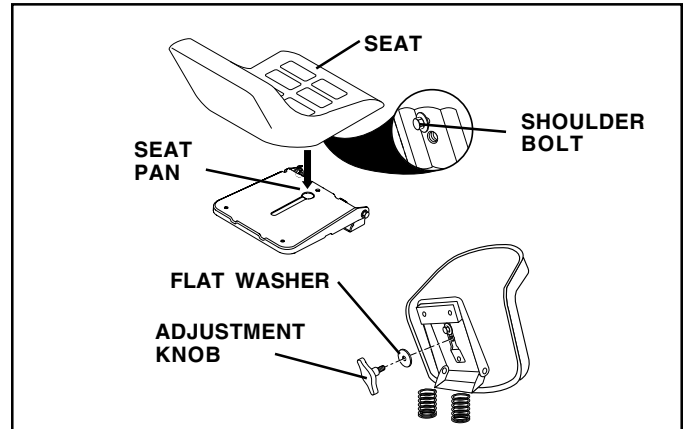

FIG. 4

NOTE: You may now roll or drive your tractor off the skid. Follow the appropriate instruction below to remove the tractor from the skid.

TO ROLL TRACTOR OFF SKID (See Operation section page 10 for location and function of controls)

- Press lift lever plunger and raise attachment lift lever to its highest position.
- Release parking brake by depressing clutch/brake pedal.
- Place freewheel control in freewheeling position to disengage transmission (See "TO TRANSPORT" in the Operation section of this manual).
- Roll tractor forward off skid.
- Remove banding holding deflector shield up against tractor.

TO DRIVE TRACTOR OFF SKID (See Operation section page 10 for location and function of controls)

⚠WARNING: Before starting, read, understand and follow all instructions in the Operation section of this manual. Be sure tractor is in a well-ventilated area. Be sure the area in front of tractor is clear of other people and objects.

- Be sure all the above assembly steps have been completed.
- Check engine oil level and fill fuel tank with gasoline.
- Place freewheel control in "transmission engaged" position.
- Sit on seat in operating position, depress clutch/brake pedal and set the parking brake.
- Place motion control lever in neutral (N) position.
- Press lift lever plunger and raise attachment lift lever to its highest position.
- Start the engine. After engine has started, move throttle control to idle position.
- Release parking brake.
- Slowly move the motion control lever forward and slowly drive tractor off skid.
- Apply brake to stop tractor, set parking brake and place motion control lever in neutral position.
- Turn ignition key to "OFF" position.

7 Continue with the instructions that follow.

ASSEMBLY

INSTALL MULCHER PLATE (If previously removed) (See Fig. 5)

- Raise and hold deflector shield in upright position.
- Place front of mulcher plate over front of mower deck opening and slide into place, as shown.
- Hook front latch into hole on front of mower deck.
- Hook rear latch into hole on back of mower deck.



CAUTION: Do not remove deflector shield from mower. Raise and hold shield when attaching mulcher plate and allow it to rest on plate while in operation.

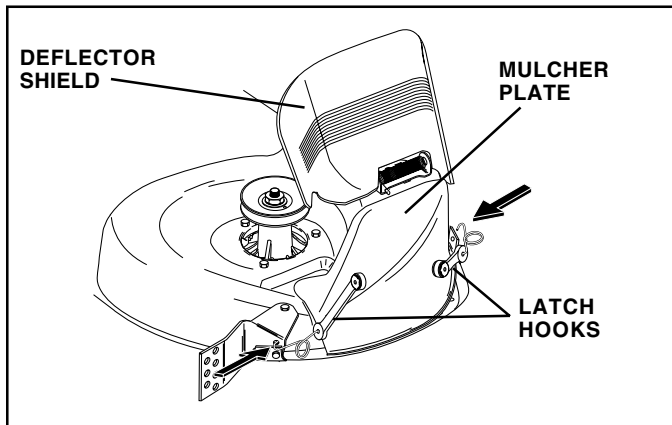

FIG. 5

TO CONVERT TO BAGGING OR DISCHARGING

Simply remove mulcher plate and store in a safe place. Your mower is now ready for discharging or installation of optional grass catcher accessory.

NOTE: It is not necessary to change blades. The mulcher blades are designed for discharging and bagging also.

CHECK TIRE PRESSURE

The tires on your tractor were overinflated at the factory for shipping purposes. Correct tire pressure is important for best cutting performance.

- Reduce tire pressure to PSI shown in "PRODUCT SPECIFICATIONS" section of this manual.

CHECK DECK LEVELNESS

For best cutting results, mower housing should be properly leveled. See "TO LEVEL MOWER HOUSING" in the Service and Adjustments section of this manual.

CHECK FOR PROPER POSITION OF ALL BELTS

See the figures that are shown for replacing motion and mower blade drive belts in the Service and Adjustments section of this manual. Verify that the belts are routed correctly.

CHECK BRAKE SYSTEM

After you learn how to operate your tractor, check to see that the brake is properly adjusted. See "TO ADJUST BRAKE" in the Service and Adjustments section of this manual.

✓ CHECKLIST

BEFORE YOU OPERATE AND ENJOY YOUR NEW TRACTOR, WE WISH TO ASSURE THAT YOU RECEIVE THE BEST PERFORMANCE AND SATISFACTION FROM THIS QUALITY PRODUCT.

PLEASE REVIEW THE FOLLOWING CHECKLIST:

- ✓ All assembly instructions have been completed.
- ✓ No remaining loose parts in carton.
- ✓ Battery is properly prepared and charged. (Minimum 1 hour at 6 amps).
- ✓ Seat is adjusted comfortably and tightened securely.
- ✓ All tires are properly inflated. (For shipping purposes, the tires were overinflated at the factory).
- ✓ Be sure mower deck is properly leveled side-to-side/front-to-rear for best cutting results. (Tires must be properly inflated for leveling).
- ✓ Check mower and drive belts. Be sure they are routed properly around pulleys and inside all belt keepers.
- ✓ Check wiring. See that all connections are still secure and wires are properly clamped.
- ✓ Before driving tractor, be sure freewheel control is in drive position.

WHILE LEARNING HOW TO USE YOUR TRACTOR, PAY EXTRA ATTENTION TO THE FOLLOWING IMPORTANT ITEMS:

- ✓ Engine oil is at proper level.
- ✓ Fuel tank is filled with fresh, clean, regular unleaded gasoline.
- ✓ Become familiar with all controls - their location and function. Operate them before you start the engine.
- ✓ Be sure brake system is in safe operating condition.
- ✓ It is important to purge the transmission before operating your tractor for the first time. Follow proper starting and transmission purging instructions (See "TO START ENGINE" and "PURGE TRANSMISSION" in the Operation section of this manual).

OPERATION

These symbols may appear on your tractor or in literature supplied with the product. Learn and understand their meaning.

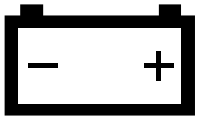

BATTERY



CAUTION OR WARNING



REVERSE



FORWARD



FAST



SLOW



ENGINE ON



ENGINE OFF



OIL PRESSURE

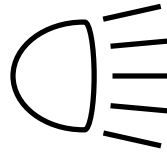

LIGHTS ON



OVER TEMP LIGHT

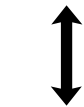

MOWER LIFT



FUEL

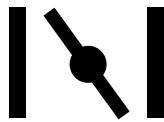

CHOKE

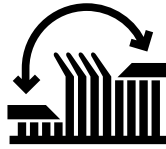

MOWER HEIGHT



PARKING BRAKE LOCKED



UNLOCKED



ATTACHMENT CLUTCH ENGAGED



REVERSE



NEUTRAL



HIGH



LOW

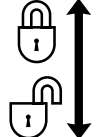

PARKING BRAKE



IGNITION

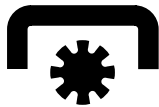

ATTACHMENT CLUTCH DISENGAGED



KEEP AREA CLEAR

SLOPE HAZARDS

(SEE SAFETY RULES SECTION)



DANGER, KEEP HANDS AND FEET AWAY

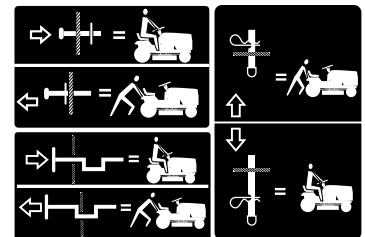

FREE WHEEL
(Automatic Models only)

OPERATION

KNOW YOUR TRACTOR

READ THIS OWNER'S MANUAL AND SAFETY RULES BEFORE OPERATING YOUR TRACTOR

Compare the illustrations with your tractor to familiarize yourself with the locations of various controls and adjustments. Save this manual for future reference.

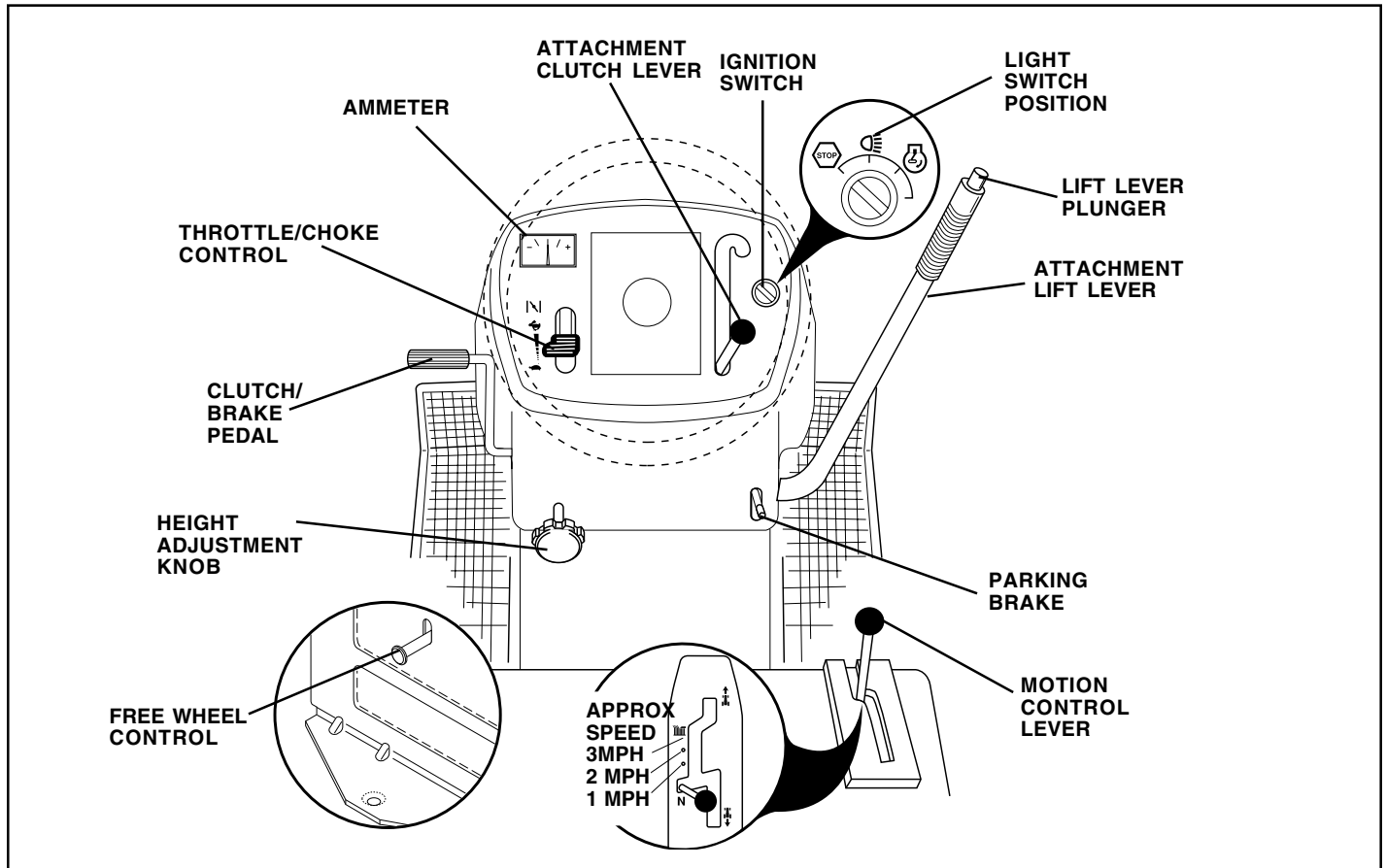

FIG. 6

Our tractors conform to the safety standards of the American National Standards Institute.

ATTACHMENT CLUTCH LEVER: Used to engage the mower blades, or other attachments mounted to your tractor.

LIGHT SWITCH: Turns the headlights on and off.

THROTTLE/CHOKE CONTROL: Used for starting and controlling engine speed.

CLUTCH/BRAKE PEDAL: Used for declutching and braking the tractor and starting the engine.

PARKING BRAKE: Locks clutch/brake pedal into the brake position.

FREEWHEEL CONTROL: Disengages transmission for pushing or slowly towing the tractor with the engine off.

HEIGHT ADJUSTMENT KNOB - Used to adjust the mower cutting height.

AMMETER: Indicates charging (+) or discharging (-) of battery.

MOTION CONTROL LEVER: Selects the speed and direction of tractor.

ATTACHMENT LIFT LEVER: Used to raise, lower, and adjust the mower deck or other attachments mounted to your tractor.

LIFT LEVER PLUNGER: Used to release attachment lift lever when changing its position.

IGNITION SWITCH: Used for starting and stopping the engine.

OPERATION



The operation of any tractor can result in foreign objects thrown into the eyes, which can result in severe eye damage. Always wear safety glasses or eye shields while operating your tractor or performing any adjustments or repairs. We recommend a wide vision safety mask over spectacles or standard safety glasses.

HOW TO USE YOUR TRACTOR

TO SET PARKING BRAKE (See Fig. 7)

Your tractor is equipped with an operator presence sensing switch. When engine is running, any attempt by the operator to leave the seat without first setting the parking brake will shut off the engine.

- Depress clutch/brake pedal into full "BRAKE" position and hold.
- Place parking brake lever in "ENGAGED" position and release pressure from clutch/brake pedal. Pedal should remain in "BRAKE" position. Make sure parking brake will hold tractor secure.

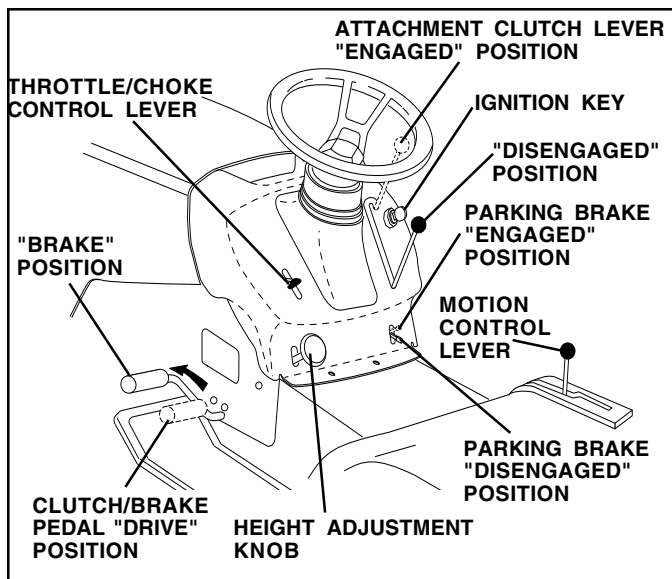

FIG. 7

STOPPING (See Fig. 7)

MOWER BLADES -

- To stop mower blades, move attachment clutch lever to "DISENGAGED" position.

GROUND DRIVE -

- To stop ground drive, depress clutch/brake pedal into full "BRAKE" position.
- Move motion control lever to neutral (N) position.

IMPORTANT: THE MOTION CONTROL LEVER DOES NOT RETURN TO NEUTRAL (N) POSITION WHEN THE CLUTCH/BRAKE PEDAL IS DEPRESSED.

ENGINE -

- Move throttle control to slow position.

NOTE: Failure to move throttle control to slow position and allowing engine to idle before stopping may cause engine to "backfire".

- Turn ignition key to "OFF" position and remove key. Always remove key when leaving tractor to prevent unauthorized use.
- Never use choke to stop engine.

IMPORTANT: LEAVING THE IGNITION SWITCH IN ANY POSITION OTHER THAN "OFF" WILL CAUSE THE BATTERY TO BE DISCHARGED, (DEAD).

NOTE: Under certain conditions when tractor is standing idle with the engine running, hot engine exhaust gases may cause "browning" of grass. To eliminate this possibility, always stop engine when stopping tractor on grass areas.



CAUTION: Always stop tractor completely, as described above, before leaving the operator's position; to empty grass catcher, etc.

TO USE THROTTLE CONTROL (See Fig. 7)

Always operate engine at full throttle.

- Operating engine at less than full throttle reduces the battery charging rate.
- Full throttle offers the best bagging and mower performance.

TO MOVE FORWARD AND BACKWARD (See Fig. 7)

The direction and speed of movement is controlled by the motion control lever.

- Start tractor with motion control lever in neutral (N) position.
- Release parking brake.
- Slowly move motion control lever to desired position.

TO ADJUST MOWER CUTTING HEIGHT (See Fig. 7)

The cutting height is controlled by turning the height adjustment knob in desired direction.

- Turn knob clockwise (↻) to raise cutting height.
- Turn knob counterclockwise (↺) to lower cutting height.

The cutting height range is approximately 1-1/2" to 4". The heights are measured from the ground to the blade tip with the engine not running. These heights are approximate and may vary depending upon soil conditions, height of grass and types of grass being mowed.

- The average lawn should be cut to approximately 2-1/2 inches during the cool season and to over 3 inches during hot months. For healthier and better looking lawns, mow often and after moderate growth.
- For best cutting performance, grass over 6 inches in height should be mowed twice. Make the first cut relatively high; the second to desired height.

OPERATION

TO ADJUST GAUGE WHEELS (See Fig. 8)

Gauge wheels are properly adjusted when they are slightly off the ground when mower is at the desired cutting height in operating position. Gauge wheels then keep the deck in proper position to help prevent scalping in most terrain conditions.

NOTE: Adjust gauge wheels with tractor on a flat level surface.

- Adjust mower to desired cutting height (See "TO ADJUST MOWER CUTTING HEIGHT" in the Operation section of this manual).
- With mower in desired height of cut position, gauge wheels should be assembled so they are slightly off the ground. Install gauge wheel in appropriate hole with shoulder bolt, 3/8 washer, and 3/8-16 locknut and tighten securely.
- Repeat for opposite side installing gauge wheel in same adjustment hole.

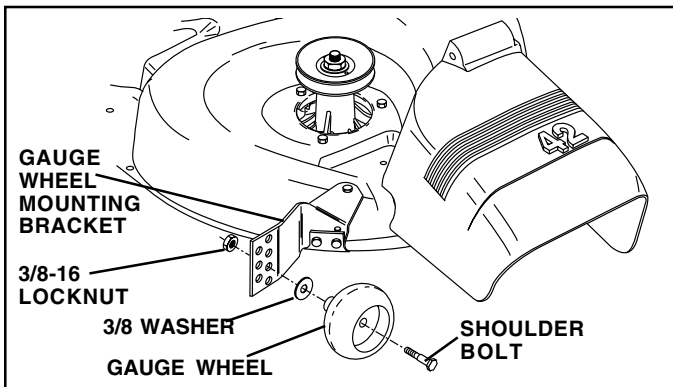

FIG. 8

TO OPERATE MOWER (See Fig. 9)

Your tractor is equipped with an operator presence sensing switch. Any attempt by the operator to leave the seat with the engine running and the attachment clutch engaged will shut off the engine.

- Select desired height of cut.
- Lower mower with attachment lift control.
- Start mower blades by engaging attachment clutch control.
- TO STOP MOWER BLADES - disengage attachment clutch control.

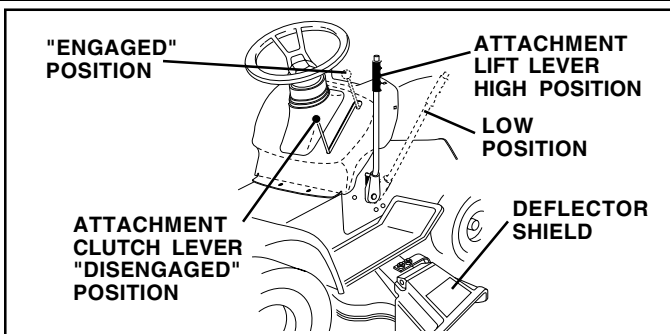
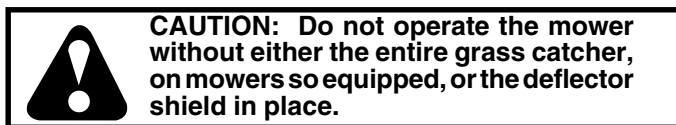

FIG. 9

TO OPERATE ON HILLS



- Choose the slowest speed before starting up or down hills.
- Avoid stopping or changing speed on hills.
- If slowing is necessary, move throttle control lever to slower position.
- If stopping is absolutely necessary, push clutch/brake pedal quickly to brake position and engage parking brake.
- Move motion control lever to neutral (N) position.

IMPORTANT: THE MOTION CONTROL LEVER DOES NOT RETURN TO NEUTRAL (N) POSITION WHEN THE CLUTCH/BRAKE PEDAL IS DEPRESSED.

- To restart movement, slowly release parking brake and clutch/brake pedal.
- Slowly move motion control lever to slowest setting.
- Make all turns slowly.

TO TRANSPORT (See Figs. 6 and 10)

When pushing or towing your tractor, be sure to disengage transmission by placing freewheel control in freewheeling position. Free wheel control is located at the rear drawbar of tractor.

- Raise attachment lift to highest position with attachment lift control.
- Pull freewheel control out and down into the slot and release so it is held in the disengaged position.
- Do not push or tow tractor at more than two (2) MPH.
- To reengage transmission, reverse above procedure.

NOTE: To protect hood from damage when transporting your tractor on a truck or a trailer, be sure hood is closed and secured to tractor. Use an appropriate means of tying hood to tractor (rope, cord, etc.).

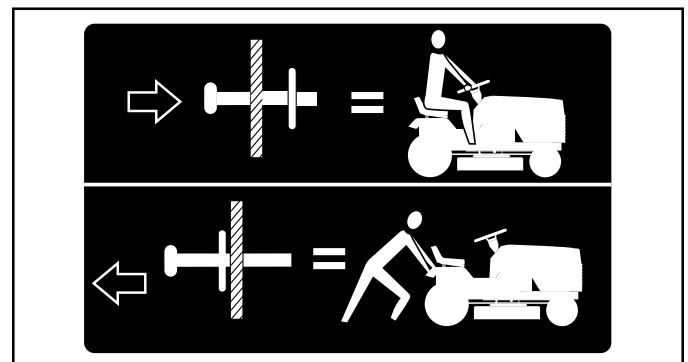

FIG. 10

TOWING CARTS AND OTHER ATTACHMENTS

Tow only the attachments that are recommended by and comply with specifications of the manufacturer of your tractor. Use common sense when towing. Too heavy of a load, while on a slope, is dangerous. Tires can lose traction with the ground and cause you to lose control of your tractor.

OPERATION

BEFORE STARTING THE ENGINE

CHECK ENGINE OIL LEVEL

- The engine in your tractor has been shipped, from the factory, already filled with summer weight oil.
- Check engine oil with tractor on level ground.
- Unthread and remove oil fill cap/dipstick; wipe oil off. Reinsert the dipstick into the tube and rest oil fill cap on the tube. Do not thread the cap onto the tube. Remove and read oil level. If necessary, add oil until "FULL" mark on dipstick is reached. Do not overfill.
- For cold weather operation you should change oil for easier starting (See "OIL VISCOSITY CHART" in the Customer Responsibilities section of this manual).
- To change engine oil, see the Customer Responsibilities section in this manual.

ADD GASOLINE

- Fill fuel tank. Use fresh, clean, regular unleaded gasoline with a minimum of 87 octane. (Use of leaded gasoline will increase carbon and lead oxide deposits and reduce valve life). Do not mix oil with gasoline. Purchase fuel in quantities that can be used within 30 days to assure fuel freshness.

IMPORTANT: WHEN OPERATING IN TEMPERATURES BELOW 32°F(0°C), USE FRESH, CLEAN WINTER GRADE GASOLINE TO HELP INSURE GOOD COLD WEATHER STARTING.

WARNING: Experience indicates that alcohol blended fuels (called gasohol or using ethanol or methanol) can attract moisture which leads to separation and formation of acids during storage. Acidic gas can damage the fuel system of an engine while in storage. To avoid engine problems, the fuel system should be emptied before storage of 30 days or longer. Drain the gas tank, start the engine and let it run until the fuel lines and carburetor are empty. Use fresh fuel next season. See Storage Instructions for additional information. Never use engine or carburetor cleaner products in the fuel tank or permanent damage may occur.



CAUTION: Fill to bottom of gas tank filler neck. Do not overfill. Wipe off any spilled oil or fuel. Do not store, spill or use gasoline near an open flame.

TO START ENGINE (See Fig. 6)

When starting the engine for the first time or if the engine has run out of fuel, it will take extra cranking time to move fuel from the tank to the engine.

- Be sure freewheel control is in the transmission engaged position.
- Sit on seat in operating position, depress clutch/brake pedal and set parking brake.
- Place motion control lever in neutral (N) position.
- Move attachment clutch to "DISENGAGED" position.
- Move throttle control to choke position.

NOTE: Before starting, read the warm and cold starting procedures below.

- Insert key into ignition and turn key clockwise to "START" position and release key as soon as engine starts. Do not run starter continuously for more than fifteen seconds per minute. If the engine does not start after several attempts, move throttle control to fast position, wait a few minutes and try again. If engine still does not start, move the throttle control back to the choke position and retry.

WARM WEATHER STARTING (50° F and above)

- When engine starts, move the throttle control to the fast position.
- The attachments and ground drive can now be used. If the engine does not accept the load, restart the engine and allow it to warm up for one minute using the choke as described above.

COLD WEATHER STARTING (50° F AND BELOW)

- When engine starts, allow engine to run with the throttle control in the choke position until the engine runs roughly, then move throttle control to fast position. This may require an engine warm-up period from several seconds to several minutes, depending on the temperature.

AUTOMATIC TRANSMISSION WARM UP

- Before driving the unit in cold weather, the transmission should be warmed up as follows:
 - Be sure the tractor is on level ground.
 - Place the motion control lever in neutral. Release the parking brake and let the clutch/brake slowly return to operating position.
 - Allow one minute for transmission to warm up. This can be done during the engine warm up period.
- The attachments can also be used during the engine warm-up period after the transmission has been warmed up.

NOTE: If at a high altitude (above 3000 feet) or in cold temperatures (below 32 F) the carburetor fuel mixture may need to be adjusted for best engine performance. See "TO ADJUST CARBURETOR" in the Service and Adjustments section of this manual.

PURGE TRANSMISSION



CAUTION: Never engage or disengage freewheel lever while the engine is running.

To ensure proper operation and performance, it is recommended that the transmission be purged before operating tractor for the first time. This procedure will remove any trapped air inside the transmission which may have developed during shipping of your tractor.

IMPORTANT: SHOULD YOUR TRANSMISSION REQUIRE REMOVAL FOR SERVICE OR REPLACEMENT, IT SHOULD BE PURGED AFTER REINSTALLATION BEFORE OPERATING THE TRACTOR.

- Place tractor safely on level surface with engine off and parking brake set.
- Disengage transmission by placing freewheel control in freewheeling position (See "TO TRANSPORT" in this section of manual).

OPERATION

- Sitting in the tractor seat, start engine. After the engine is running, move throttle control to slow position. With motion control lever in neutral (N) position, slowly disengage clutch/brake pedal.
- Move motion control lever to full forward position and hold for five (5) seconds. Move lever to full reverse position and hold for five (5) seconds. Repeat this procedure three (3) times.

NOTE: During this procedure there will be no movement of drive wheels. The air is being removed from hydraulic drive system.

- Move motion control lever to neutral (N) position. Shut-off engine and set parking brake.
- Engage transmission by placing freewheel control in driving position (See "TO TRANSPORT" in this section of manual).
- Sitting in the tractor seat, start engine. After the engine is running, move throttle control to half (1/2) speed. With motion control lever in neutral (N) position, slowly disengage clutch/brake pedal.
- Slowly move motion control lever forward, after the tractor moves approximately five (5) feet, slowly move motion control lever to reverse position. After the tractor moves approximately five (5) feet return the motion control lever to the neutral (N) position. Repeat this procedure with the motion control lever three (3) times.
- Your tractor is now purged and now ready for normal operation.

MOWING TIPS

- Mower should be properly leveled for best mowing performance. See "TO LEVEL MOWER HOUSING" in the Service and Adjustments section of this manual.
- The left hand side of mower should be used for trimming.
- Drive so that clippings are discharged onto the area that has been cut. Have the cut area to the right of the machine. This will result in a more even distribution of clippings and more uniform cutting.
- When mowing large areas, start by turning to the right so that clippings will discharge away from shrubs, fences, driveways, etc. After one or two rounds, mow in the opposite direction making left hand turns until finished (See Fig. 11).
- If grass is extremely tall, it should be mowed twice to reduce load and possible fire hazard from dried clippings. Make first cut relatively high; the second to the desired height.
- Do not mow grass when it is wet. Wet grass will plug mower and leave undesirable clumps. Allow grass to dry before mowing.
- **Always operate engine at full throttle when mowing** to assure better mowing performance and proper discharge of material. Regulate ground speed by selecting a low enough gear to give the mower cutting performance as well as the quality of cut desired.
- When operating attachments, select a ground speed that will suit the terrain and give best performance of the attachment being used.

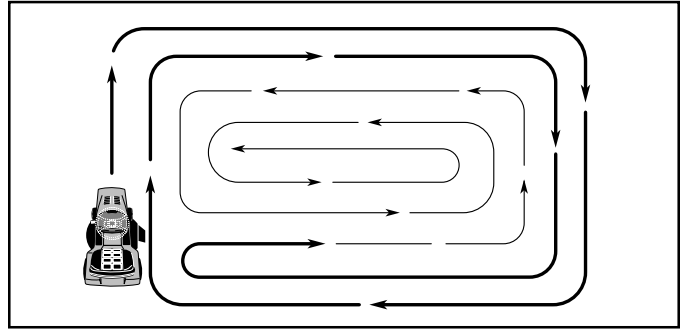

FIG. 11

MULCHING MOWING TIPS

IMPORTANT: FOR BEST PERFORMANCE, KEEP MOWER HOUSING FREE OF BUILT-UP GRASS AND TRASH. CLEAN AFTER EACH USE.

- The special mulching blade will recut the grass clippings many times and reduce them in size so that as they fall onto the lawn they will disperse into the grass and not be noticed. Also, the mulched grass will biodegrade quickly to provide nutrients for the lawn. Always mulch with your highest engine (blade) speed as this will provide the best recutting action of the blades.
- Avoid cutting your lawn when it is wet. Wet grass tends to form clumps and interferes with the mulching action. The best time to mow your lawn is the early afternoon. At this time the grass has dried and the newly cut area will not be exposed to the direct sun.
- For best results, adjust the mower cutting height so that the mower cuts off only the top one-third of the grass blades (See Fig. 12). For extremely heavy mulching, reduce your width of cut on each pass and mow slowly.
- Certain types of grass and grass conditions may require that an area be mulched a second time to completely hide the clippings. When doing a second cut, mow across or perpendicular to the first cut path.
- Change your cutting pattern from week to week. Mow north to south one week then change to east to west the next week. This will help prevent matting and graining of the lawn.

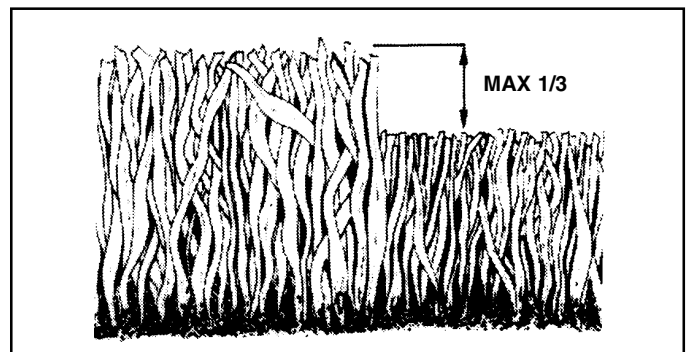

FIG. 12

CUSTOMER RESPONSIBILITIES

MAINTENANCE SCHEDULE		SERVICE INTERVALS							SERVICE DATES				
		BEFORE EACH USE	EVERY 8 HOURS	EVERY 25 HOURS	EVERY 50 HOURS	EVERY 100 HOURS	EVERY SEASON	BEFORE STORAGE					
TRACTOR	Check Brake Operation	✓	✓										
	Check Tire Pressure	✓	✓										
	Check Operator Presence and Interlock Systems	✓											
	Check for Loose Fasteners	✓				✓ ₇		✓					
	Sharpen/Replace Mower Blades			✓ ₄									
	Lubrication Chart			✓				✓					
	Check Battery Level			✓ ₆									
	Clean Battery and Terminals			✓				✓					
	Check Transaxle Cooling			✓									
	Adjust Blade Belt(s) Tension					✓ ₅							
	Adjust Motion Drive Belt(s) Tension					✓ ₅							
ENGINE	Check Engine Oil Level	✓	✓										
	Change Engine Oil			✓ _{1,2,3}				✓					
	Clean Air Filter			✓ ₂									
	Clean Air Screen			✓ ₂									
	Inspect Muffler/Spark Arrester				✓								
	Replace Oil Filter (If equipped)					✓ _{1,2}							
	Clean Engine Cooling Fins					✓ ₂							
	Replace Spark Plug					✓		✓					
	Replace Air Filter Paper Cartridge					✓ ₂							
	Replace Fuel Filter							✓					

- 1 - Change more often when operating under a heavy load or in high ambient temperatures.
 2 - Service more often when operating in dirty or dusty conditions.
 3 - If equipped with oil filter, change oil every 50 hours.
 4 - Replace blades more often when mowing in sandy soil.

- 5 - If equipped with adjustable system.
 6 - Not required if equipped with maintenance-free battery.
 7 - Tighten front axle pivot bolt to 35 ft.-lbs. maximum. Do not overtighten.

GENERAL RECOMMENDATIONS

The warranty on this tractor does not cover items that have been subjected to operator abuse or negligence. To receive full value from the warranty, operator must maintain tractor as instructed in this manual.

Some adjustments will need to be made periodically to properly maintain your tractor.

All adjustments in the Service and Adjustments section of this manual should be checked at least once each season.

- Once a year you should replace the spark plug, clean or replace air filter, and check blades and belts for wear. A new spark plug and clean air filter assure proper air-fuel mixture and help your engine run better and last longer.

BEFORE EACH USE

- Check engine oil level.
- Check brake operation.
- Check tire pressure.
- Check operator presence and interlock systems for proper operation.
- Check for loose fasteners.

LUBRICATION CHART

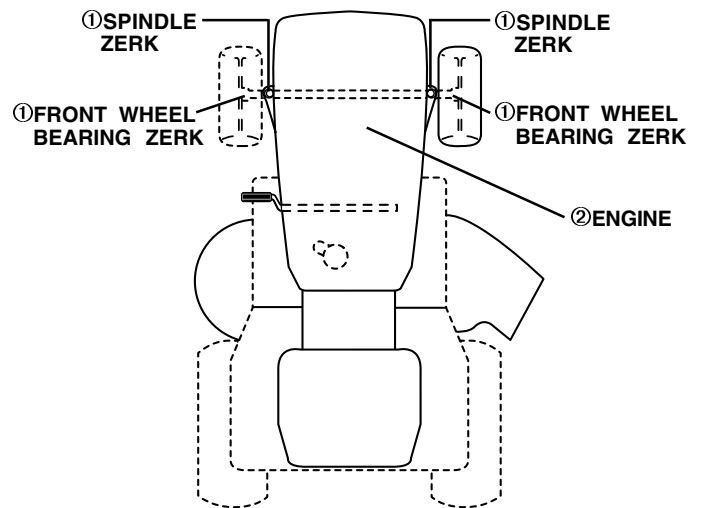

- ① GENERAL PURPOSE GREASE
 ② REFER TO CUSTOMER RESPONSIBILITIES "ENGINE" SECTION

IMPORTANT: DO NOT OIL OR GREASE THE PIVOT POINTS WHICH HAVE SPECIAL NYLON BEARINGS. VISCOUS LUBRICANTS WILL ATTRACT DUST AND DIRT THAT WILL SHORTEN THE LIFE OF THE SELF-LUBRICATING BEARINGS. IF YOU FEEL THEY MUST BE LUBRICATED, USE ONLY A DRY, POWDERED GRAPHITE TYPE LUBRICANT SPARINGLY.

CUSTOMER RESPONSIBILITIES

TRACTOR

Always observe safety rules when performing any maintenance.

BRAKE OPERATION

If tractor requires more than six (6) feet stopping distance at high speed in highest gear, then brake must be adjusted. (See "TO ADJUST BRAKE" in the Service and Adjustments section of this manual).

TIRES

- Maintain proper air pressure in all tires (See "PRODUCT SPECIFICATIONS" section of this manual).
- Keep tires free of gasoline, oil, or insect control chemicals which can harm rubber.
- Avoid stumps, stones, deep ruts, sharp objects and other hazards that may cause tire damage.

NOTE: To seal tire punctures and prevent flat tires due to slow leaks, tire sealant may be purchased from your local parts dealer. Tire sealant also prevents tire dry rot and corrosion.

OPERATOR PRESENCE SYSTEM

Be sure operator presence and interlock systems are working properly. If your tractor does not function as described, repair the problem immediately.

- The engine should not start unless the brake pedal is fully depressed and attachment clutch control is in the disengaged position.
- When the engine is running, any attempt by the operator to leave the seat without first setting the parking brake should shut off the engine.
- When the engine is running and the attachment clutch is engaged, any attempt by the operator to leave the seat should shut off the engine.
- The attachment clutch should never operate unless the operator is in the seat.

BLADE CARE

For best results mower blades must be kept sharp. Replace bent or damaged blades.

BLADE REMOVAL (See Fig. 13)

- Raise mower to highest position to allow access to blades.
- Remove hex bolt, lock washer and flat washer securing blade.
- Install new or resharpened blade with trailing edge up towards deck as shown.

IMPORTANT: TO ENSURE PROPER ASSEMBLY, CENTER HOLE IN BLADE MUST ALIGN WITH STAR ON MANDREL ASSEMBLY.

- Reassemble hex bolt, lock washer and flat washer in exact order as shown.
- Tighten bolt securely (27-35 Ft. Lbs. torque).

IMPORTANT: BLADE BOLT IS GRADE 8 HEAT TREATED.

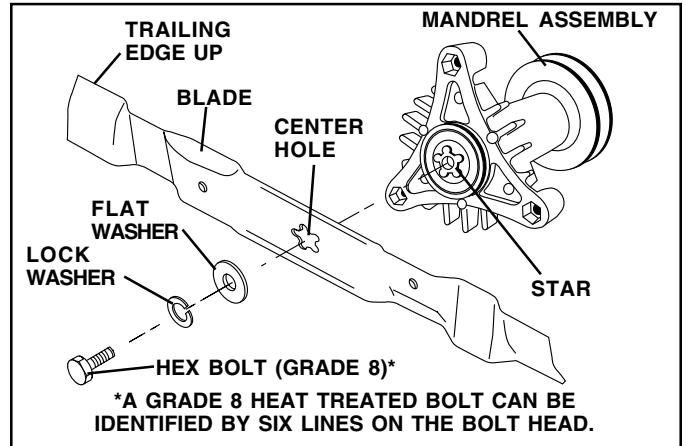

FIG. 13

TO SHARPEN BLADE (See Fig. 14)

NOTE: We do not recommend sharpening blade - but if you do, be sure the blade is balanced.

Care should be taken to keep the blade balanced. An unbalanced blade will cause excessive vibration and eventual damage to mower and engine.

- The blade can be sharpened with a file or on a grinding wheel. Do not attempt to sharpen while on the mower.
- To check blade balance, you will need a 5/8" diameter steel bolt, pin, or a cone balancer. (When using a cone balancer, follow the instructions supplied with balancer).

NOTE: Do not use a nail for balancing blade. The lobes of the center hole may appear to be centered, but are not.

- Slide blade on to an unthreaded portion of the steel bolt or pin and hold the bolt or pin parallel with the ground. If blade is balanced, it should remain in a horizontal position. If either end of the blade moves downward, sharpen the heavy end until the blade is balanced.

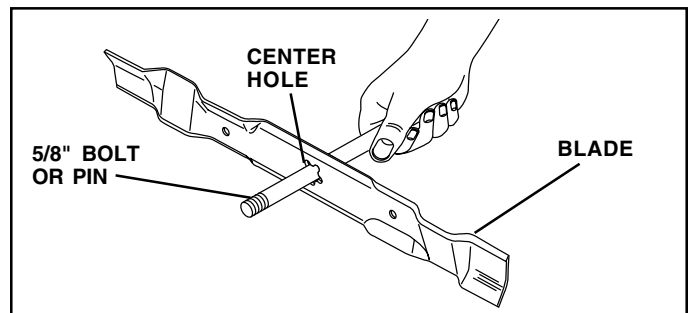

FIG. 14

BATTERY

Your tractor has a battery charging system which is sufficient for normal use. However, periodic charging of the battery with an automotive charger will extend its life.

- Keep battery and terminals clean.
- Keep battery bolts tight.
- Keep small vent holes open.
- Recharge at 6-10 amperes for 1 hour.

NOTE: The original equipment battery on your tractor is maintenance free. Do not attempt to open or remove caps or covers. Adding or checking level of electrolyte is not necessary.

CUSTOMER RESPONSIBILITIES

TO CLEAN BATTERY AND TERMINALS

Corrosion and dirt on the battery and terminals can cause the battery to “leak” power.

- Open battery box door.
- Disconnect BLACK battery cable first then RED battery cable and remove battery from tractor.
- Rinse the battery with plain water and dry.
- Clean terminals and battery cable ends with wire brush until bright.
- Coat terminals with grease or petroleum jelly.
- Reinstall battery (See “CONNECT BATTERY” in the Assembly section of this manual).

V-BELTS

Check V-belts for deterioration and wear after 100 hours of operation and replace if necessary. The belts are not adjustable. Replace belts if they begin to slip from wear.

TRANSAXLE COOLING

The transmission fan and cooling fins should be kept clean to assure proper cooling.

Do not attempt to clean fan or transmission while engine is running or while the transmission is hot. To prevent possible damage to seals, do not use high pressure water or steam to clean transaxle.

- Inspect cooling fan to be sure fan blades are intact and clean.
- Inspect cooling fins for dirt, grass clippings and other materials. To prevent damage to seals, do not use compressed air or high pressure sprayer to clean cooling fins.

TRANSAXLE PUMP FLUID

The transaxle was sealed at the factory and fluid maintenance is not required for the life of the transaxle. Should the transaxle ever leak or require servicing, contact your nearest authorized service center/department.

ENGINE

LUBRICATION

Only use high quality detergent oil rated with API service classification SF-SJ. Select the oil’s SAE viscosity grade according to your expected operating temperature.

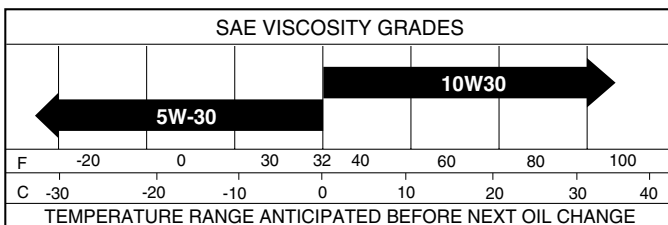

Change the oil after every 50 hours of operation or at least once a year if the tractor is not used for 50 hours in one year.

Check the crankcase oil level before starting the engine and after each eight (8) hours of operation. Tighten oil fill cap/dipstick securely each time you check the oil level.

TO CHANGE ENGINE OIL (See Fig. 15)

Determine temperature range expected before oil change. All oil must meet API service classification SF-SJ.

- Be sure tractor is on level surface.
- Oil will drain more freely when warm.
- Catch oil in a suitable container.
- Remove oil fill cap/dipstick. Be careful not to allow dirt to enter the engine when changing oil.
- Remove cap from bottom fitting of drain valve and install the drain tube onto the fitting.
- Unlock drain valve by pushing inward and turning counterclockwise.
- To open, pull out on the drain valve.
- After oil has drained completely, close and lock the drain valve by pushing inward and turning clockwise until the pin is in the locked position as shown.
- Remove the drain tube and replace the cap onto the bottom fitting of the drain valve.
- Refill engine with oil through oil fill dipstick tube. Pour slowly. Do not overfill. For approximate capacity see “PRODUCT SPECIFICATIONS” section of this manual.
- Use gauge on oil fill cap/dipstick for checking level. Insert dipstick into the tube and rest the oil fill cap on the tube. Do not thread the cap onto the tube when taking reading. Keep oil at “FULL” line on dipstick. Tighten cap onto the tube securely when finished.

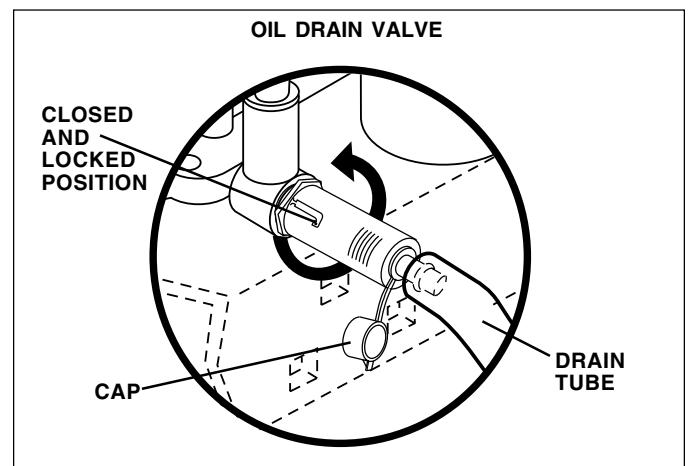

FIG. 15

CLEAN AIR SCREEN

Air screen must be kept free of dirt and chaff to prevent engine damage from overheating. Clean with a wire brush or compressed air to remove dirt and stubborn dried gum fibers.

CUSTOMER RESPONSIBILITIES

CLEAN AIR INTAKE/COOLING AREAS

To insure proper cooling, make sure the grass screen, cooling fins, and other external surfaces of the engine are kept clean at all times.

Every 100 hours of operation (more often under extremely dusty, dirty conditions), remove the blower housing and other cooling shrouds. Clean the cooling fins and external surfaces as necessary. Make sure the cooling shrouds are reinstalled.

NOTE: Operating the engine with a blocked grass screen, dirty or plugged cooling fins, and/or cooling shrouds removed will cause engine damage due to overheating.

AIR FILTER (See Fig. 16)

Your engine will not run properly using a dirty air filter. Clean the foam pre-cleaner after every 25 hours of operation or every season. Service paper cartridge every 100 hours of operation or every season, whichever occurs first.

Service air cleaner more often under dusty conditions.

- Remove knob and cover.
- Remove wing nut and air cleaner from base.

TO SERVICE PRE-CLEANER

- Slide foam pre-cleaner off cartridge.
- Wash it in liquid detergent and water.
- Squeeze it dry in a clean cloth. Allow it to dry.
- Saturate it in engine oil. Wrap it in clean, absorbent cloth and squeeze to remove excess oil.

TO SERVICE CARTRIDGE

- Replace a dirty, bent, or damaged cartridge.

NOTE: Do not wash the paper cartridge or use pressurized air, as this will damage the cartridge.

- Reinstall the pre-cleaner (cleaned and oiled) over the paper cartridge.
- Reassemble air cleaner, wing nut, cover and tighten knob securely.

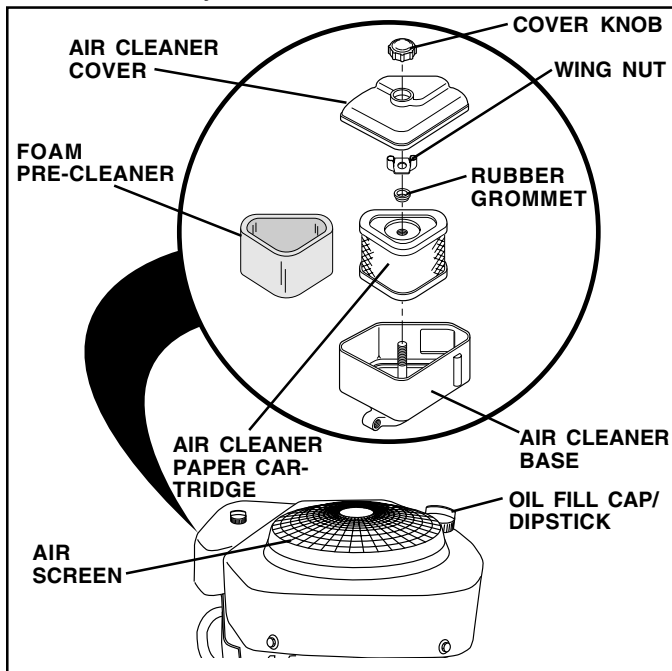

FIG. 16

MUFFLER

Inspect and replace corroded muffler and spark arrester (if equipped) as it could create a fire hazard and/or damage.

SPARK PLUGS

Replace spark plugs at the beginning of each mowing season or after every 100 hours of operation, whichever occurs first. Spark plug type and gap setting are shown in "PRODUCT SPECIFICATIONS" section of this manual.

ENGINE OIL FILTER

Replace the engine oil filter every season or every other oil change if the tractor is used more than 100 hours in one year.

IN-LINE FUEL FILTER (See Fig. 17)

The fuel filter should be replaced once each season. If fuel filter becomes clogged, obstructing fuel flow to carburetor, replacement is required.

- With engine cool, remove filter and plug fuel line sections.
- Place new fuel filter in position in fuel line with arrow pointing towards carburetor.
- Be sure there are no fuel line leaks and clamps are properly positioned.
- Immediately wipe up any spilled gasoline.

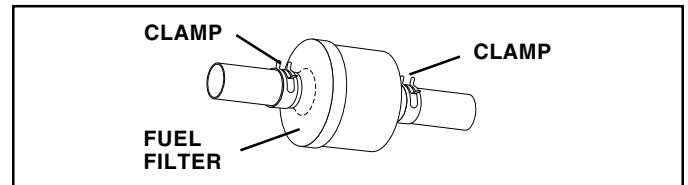

FIG. 17

CLEANING

- Clean engine, battery, seat, finish, etc. of all foreign matter.
- Keep finished surfaces and wheels free of all gasoline, oil, etc.
- Protect painted surfaces with automotive type wax.

We do not recommend using a garden hose to clean your tractor unless the electrical system, muffler, air filter and carburetor are covered to keep water out. Water in engine can result in a shortened engine life.

SERVICE AND ADJUSTMENTS



CAUTION: BEFORE PERFORMING ANY SERVICE OR ADJUSTMENTS:

- Depress clutch/brake pedal fully and set parking brake.
- Place motion control lever in neutral (N) position.
- Place attachment clutch in "DISENGAGED" position.
- Turn ignition key "OFF" and remove key.
- Make sure the blades and all moving parts have completely stopped.
- Disconnect spark plug wire from spark plug and place wire where it cannot come in contact with plug.

TRACTOR

TO REMOVE MOWER (See Fig. 18)

Mower will be easier to remove from the right side of tractor.

- Place attachment clutch in "DISENGAGED" position.
- Move attachment lift lever forward to lower mower to its lowest position.
- Roll belt off engine pulley.
- Remove small retainer spring, and lift clutch spring off pulley bolt.
- Remove large retainer spring, slide collar off and push housing guide out of bracket.
- Disconnect anti-swaybar from chassis bracket by removing retainer spring.
- Disconnect suspension arms from rear deck brackets by removing retainer springs.
- Disconnect front links from deck by removing retainer springs.
- Raise lift lever to raise suspension arms. Slide mower out from under tractor.

IMPORTANT: IF AN ATTACHMENT OTHER THAN THE MOWER DECK IS TO BE MOUNTED ON THE TRACTOR, REMOVE THE FRONT LINKS AND HOOK THE CLUTCH SPRING INTO SQUARE HOLE IN FRAME.

TO INSTALL MOWER (See Fig.18)

- Raise attachment lift lever to its highest position.
- Slide mower under tractor with deflector shield to right side of tractor.
- Lower lift lever to its lowest position.
- Install mower in reverse order of removal instructions.

TO LEVEL MOWER HOUSING

Adjust the mower while tractor is parked on level ground or driveway. Make sure tires are properly inflated (See "PRODUCT SPECIFICATIONS" section of this manual). If tires are over or underinflated, you will not properly adjust your mower.

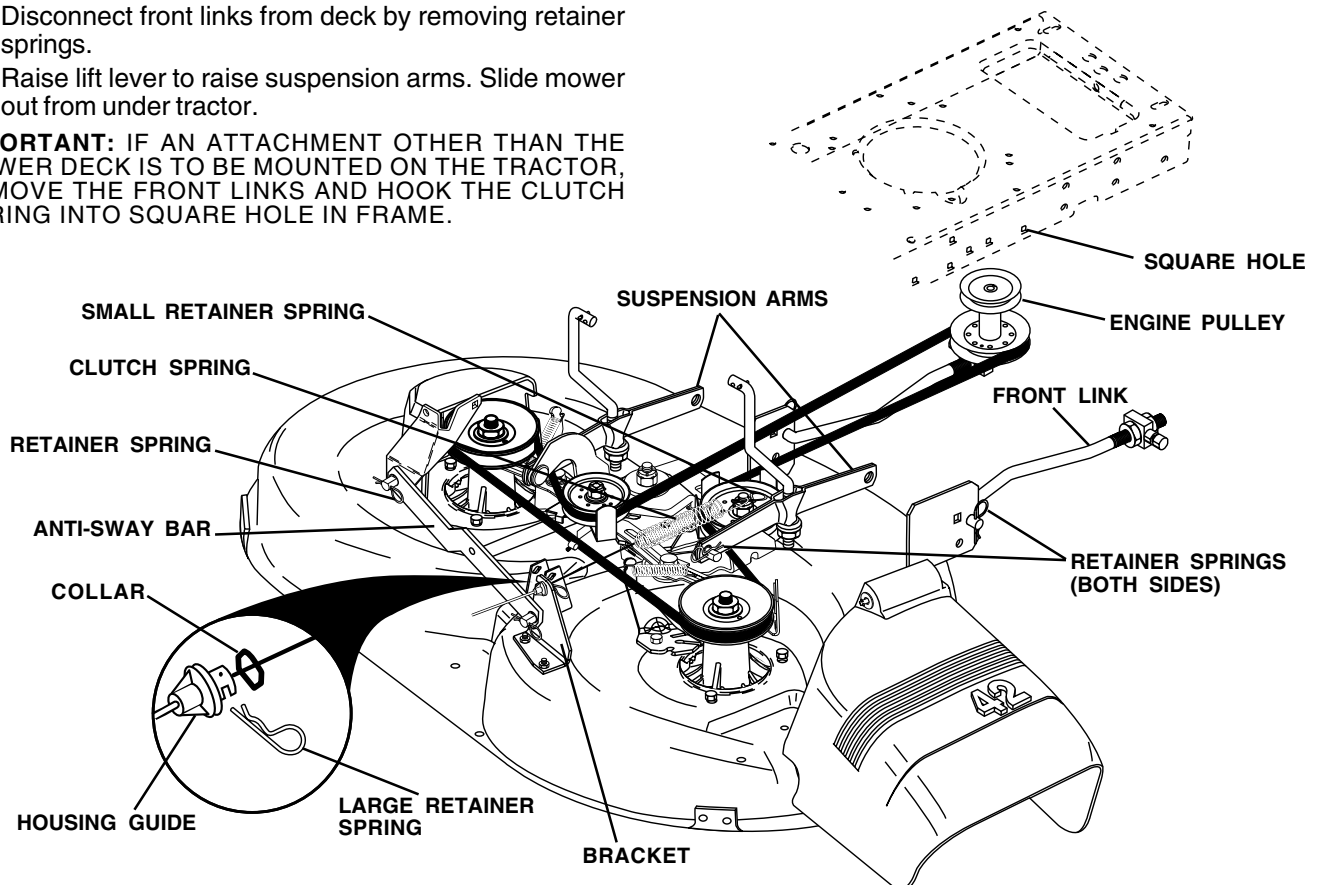

Fig. 18

SERVICE AND ADJUSTMENTS

SIDE-TO-SIDE ADJUSTMENT (See Figs. 19 and 20)

- Raise mower to its highest position.
- At the midpoint of both sides of mower, measure height from bottom edge of mower to ground. Distance "A" on both sides of mower should be the same or within 1/4" of each other.
- If adjustment is necessary, make adjustment on one side of mower only.
- To raise one side of mower, tighten lift link adjustment nut on that side.
- To lower one side of mower, loosen lift link adjustment nut on that side.

NOTE: Three full turns of adjustment nut will change mower height about 1/8".

- Recheck measurements after adjusting.

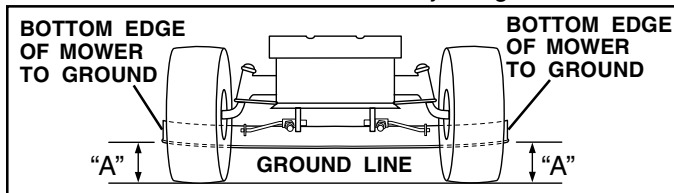

FIG. 19

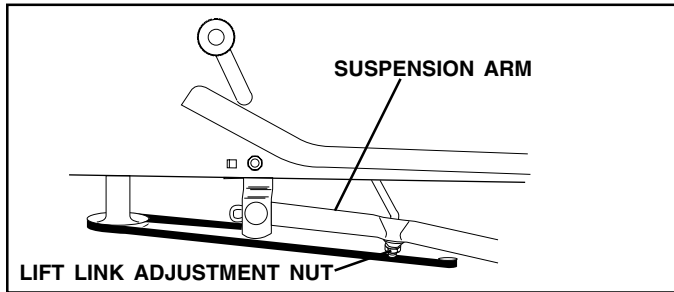

FIG. 20

FRONT-TO-BACK ADJUSTMENT (See Figs. 21 and 22)

IMPORTANT: DECK MUST BE LEVEL SIDE-TO-SIDE. IF THE FOLLOWING FRONT-TO-BACK ADJUSTMENT IS NECESSARY, BE SURE TO ADJUST BOTH FRONT LINKS EQUALLY SO MOWER WILL STAY LEVEL SIDE-TO-SIDE.

To obtain the best cutting results, the mower housing should be adjusted so that the front is approximately 1/8" to 1/2" lower than the rear when the mower is in its highest position. Check adjustment on right side of tractor. Measure distance "D" directly in front and behind the mandrel at bottom edge of mower housing as shown.

- Before making any necessary adjustments, check that both front links are equal in length.
- If links are not equal in length, adjust one link to same length as other link.
- To lower front of mower loosen nut "E" on both front links an equal number of turns.
- When distance "D" is 1/8" to 1/2" lower at front than rear, tighten nuts "F" against trunnion on both front links.
- To raise front of mower, loosen nut "F" from trunnion on both front links. Tighten nut "E" on both front links an equal number of turns.
- When distance "D" is 1/8" to 1/2" lower at front than rear, tighten nut "F" against trunnion on both front links.
- Recheck side-to-side adjustment.

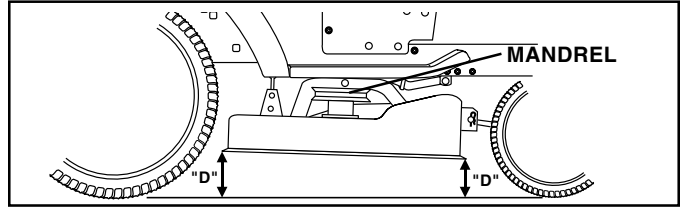

FIG. 21

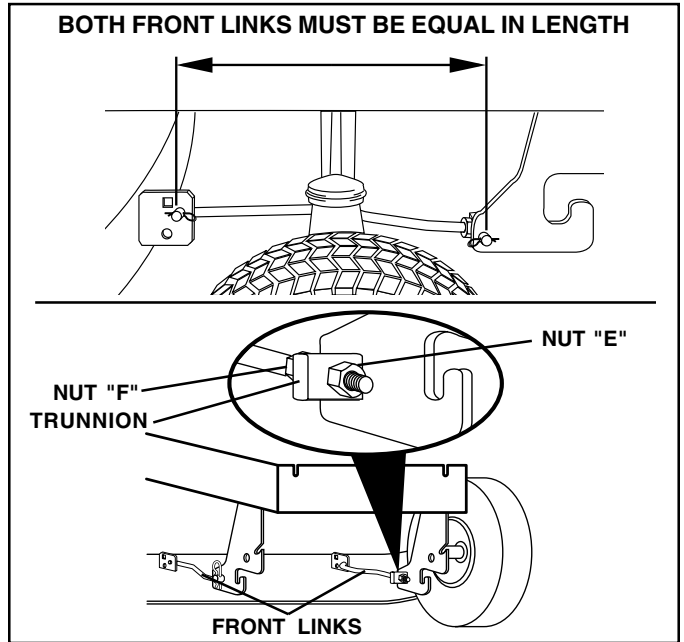

FIG. 22

TO REPLACE MOWER BLADE DRIVE BELT (See Fig. 23)

The mower blade drive belt may be replaced without tools. Park the tractor on level surface. Engage parking brake.

BELT REMOVAL -

- Remove mower from tractor (See "TO REMOVE MOWER" in this section of this manual).
- Work belt off both mandrel pulleys and idler pulleys.
- Pull belt away from mower.

BELT INSTALLATION -

- Install new belt in reverse order of removal.
- Make sure belt is in all pulley grooves and inside all belt guides.
- Install mower in reverse order of removal instructions.

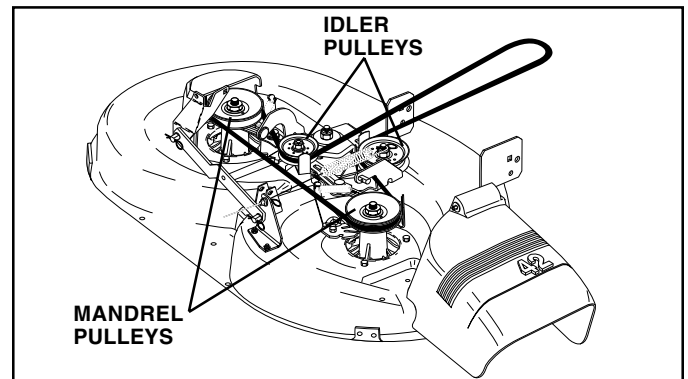

FIG. 23

SERVICE AND ADJUSTMENTS

TO ADJUST BRAKE (See Fig. 24)

Your tractor is equipped with an adjustable brake system which is mounted on the side of the transaxle.

If tractor requires more than six (6) feet stopping distance at high speed in highest gear on a level dry concrete or paved surface, then brake must be adjusted.

- Depress clutch/brake pedal and engage parking brake.
- Measure distance between brake operating arm and nut "A" on brake rod.
- If distance is other than 1-9/16", loosen jam nut and turn nut "A" until distance becomes 1-9/16". Retighten jam nut against nut "A".
- Road test tractor for proper stopping distance as stated above. Readjust if necessary. If stopping distance is still greater than six (6) feet in highest gear, further maintenance is necessary. Contact your nearest authorized service center/department.

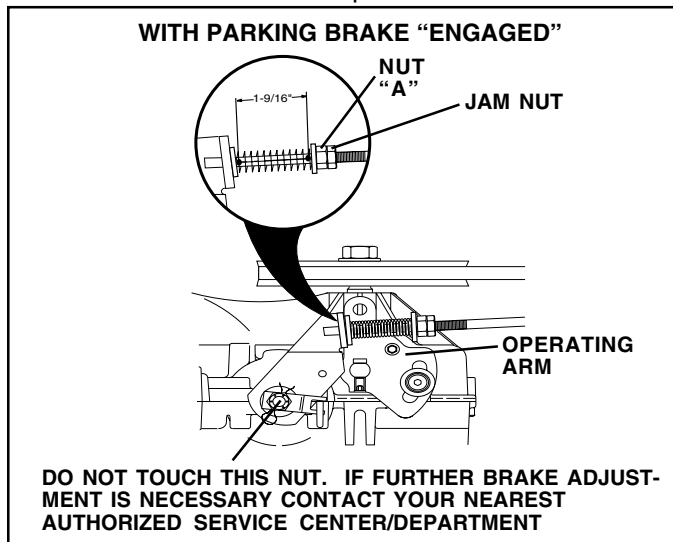

FIG. 24

TO REPLACE MOTION DRIVE BELT (See Fig. 25)

Park the tractor on level surface. Engage parking brake. For assistance, there is a belt installation guide decal on bottom side of left footrest.

- Remove mower (See "TO REMOVE MOWER" in this section of this manual.)
- Remove belt from stationary idler and clutching idler.
- Pull belt slack toward rear of tractor. Carefully remove belt upwards from transmission input pulley and over cooling fan blades.
- Pull belt toward front of tractor and remove downward from around engine pulley.
- Install new belt by reversing above procedure.

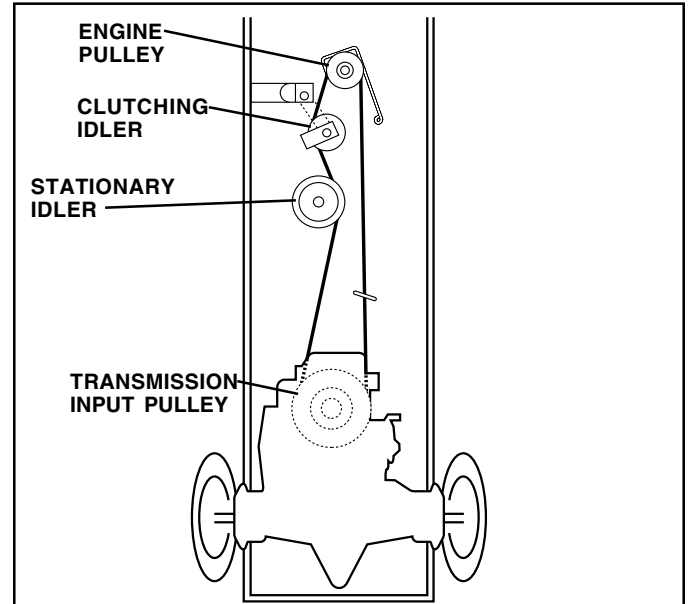

FIG. 25

TRANSAXLE MOTION CONTROL LEVER NEUTRAL ADJUSTMENT (See Fig. 26)

The motion control lever has been preset at the factory and adjustment should not be necessary.

- Loosen adjustment bolt in front of the right rear wheel, and lightly tighten.
- Start engine and move motion control lever until tractor does not move forward or backward.
- Hold motion control lever in that position and turn engine off.
- While holding motion control lever in place, loosen the adjustment bolt.
- Move motion control lever to the neutral (N) (lock gate) position.
- Tighten adjustment bolt securely.

NOTE: If additional clearance is needed to get to adjustment bolt, move mower deck height to the lowest position.

After above adjustment is made, if the tractor still creeps forward or backward while motion control lever is in neutral position, follow these steps:

- Loosen the adjustment bolt.
- Move the motion control lever 1/4 to 1/2 inch in the direction it is trying to creep.
- Tighten adjustment bolt securely.
- Start engine and test.
- If tractor still creeps, repeat above steps until satisfied.

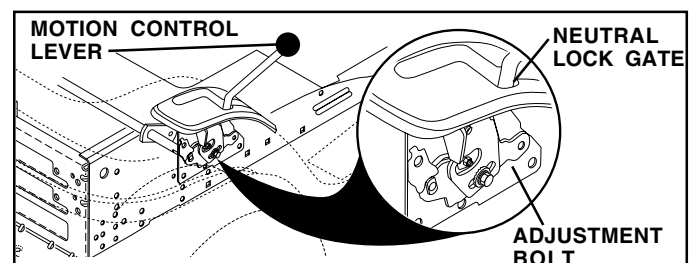

FIG. 26

SERVICE AND ADJUSTMENTS

TRANSMISSION REMOVAL/REPLACEMENT

Should your transmission require removal for service or replacement, it should be purged after reinstallation and before operating the tractor. See "PURGE TRANSMISSION" in the Operation section of this manual.

TO ADJUST STEERING WHEEL ALIGNMENT

If steering wheel crossbars are not horizontal (left to right) when wheels are positioned straight forward, remove steering wheel and reassemble per instructions in the Assembly section of this manual.

FRONT WHEEL TOE-IN/CAMBER

The front wheel toe-in and camber are not adjustable on your tractor. If damage has occurred to affect the front wheel toe-in or camber, contact your nearest authorized service center/department.

TO REMOVE WHEEL FOR REPAIRS

(See Fig. 27)

- Block up axle securely.
- Remove axle cover, retaining ring and washers to allow wheel removal (rear wheel contains a square key - Do not lose).
- Repair tire and reassemble.
- On rear wheels only: align grooves in rear wheel hub and axle. Insert square key.
- Replace washers and snap retaining ring securely in axle groove.
- Replace axle cover.

NOTE: To seal tire punctures and prevent flat tires due to slow leaks, tire sealant may be purchased from your local parts dealer. Tire sealant also prevents tire dry rot and corrosion.

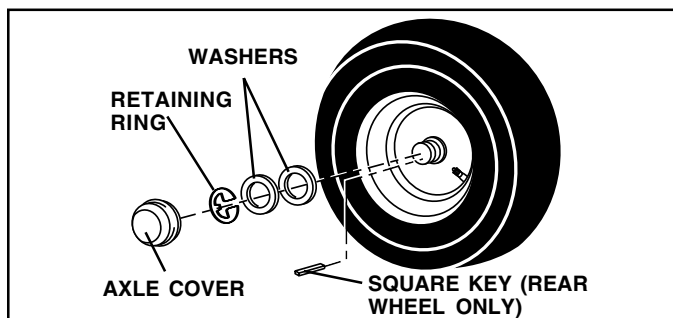

FIG. 27

TO START ENGINE WITH A WEAK BATTERY

(See Fig. 28)



CAUTION: Lead-acid batteries generate explosive gases. Keep sparks, flame and smoking materials away from batteries. Always wear eye protection when around batteries.

If your battery is too weak to start the engine, it should be recharged. If "jumper cables" are used for emergency starting, follow this procedure:

IMPORTANT: YOUR TRACTOR IS EQUIPPED WITH A 12 VOLT NEGATIVE GROUND SYSTEM. THE OTHER VEHICLE MUST ALSO BE A 12 VOLT NEGATIVE GROUND SYSTEM. DO NOT USE YOUR TRACTOR

BATTERY TO START OTHER VEHICLES.

TO ATTACH JUMPER CABLES -

- Connect each end of the RED cable to the POSITIVE (+) terminal of each battery, taking care not to short against chassis.
- Connect one end of the BLACK cable to the NEGATIVE (-) terminal of fully charged battery.
- Connect the other end of the BLACK cable to good CHASSIS GROUND, away from fuel tank and battery.

TO REMOVE CABLES, REVERSE ORDER -

- BLACK cable first from chassis and then from the fully charged battery.
- RED cable last from both batteries.

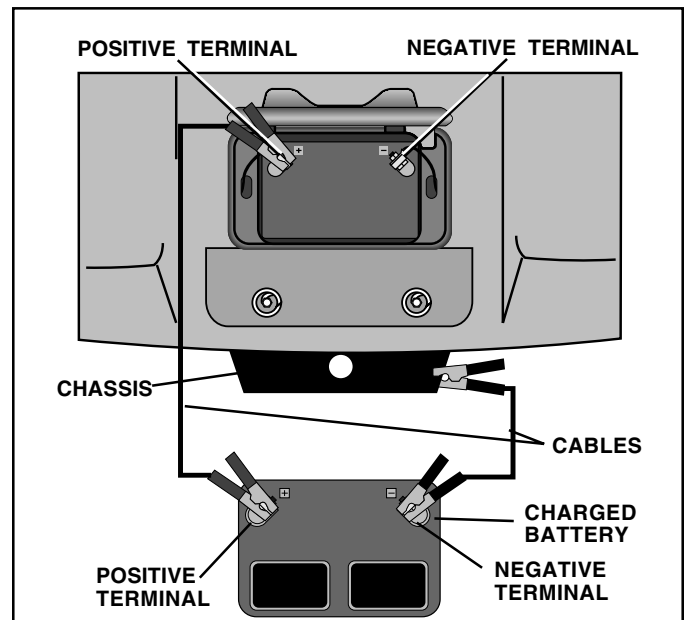

FIG. 28

TO REPLACE HEADLIGHT BULB

- Raise hood.
- Pull bulb holder out of the hole in the backside of the grill.
- Replace bulb in holder and push bulb holder securely back into the hole in the backside of the grill.
- Close hood.

INTERLOCKS AND RELAYS

Loose or damaged wiring may cause your tractor to run poorly, stop running, or prevent it from starting.

- Check wiring. See electrical wiring diagram in the Repair Parts section.

TO REPLACE FUSE

Replace with 20 amp automotive-type plug-in fuse. The fuse holder is located behind the dash.

TO REMOVE HOOD AND GRILL ASSEMBLY

(See Fig. 29)

- Raise hood.
- Unsnap headlight wire connector.
- Stand in front of tractor. Grasp hood at sides, tilt toward engine and lift off of tractor.
- To replace, reverse above procedure.

SERVICE AND ADJUSTMENTS

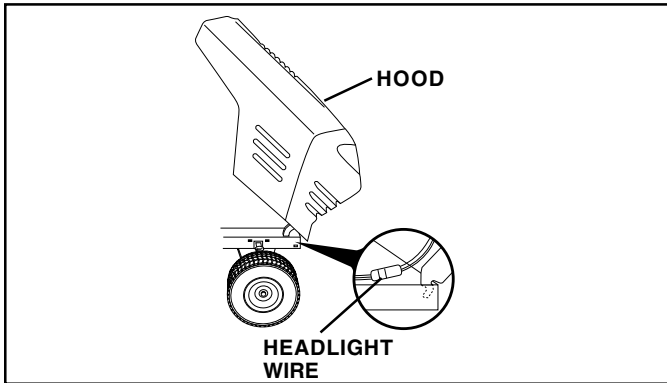

FIG. 29

ENGINE

Maintenance, repair, or replacement of the emission control devices and systems, which are being done at the customer's expense, may be performed by any non-road engine repair establishment or individual. Warranty repairs must be performed by an authorized engine manufacturer's service outlet.

TO ADJUST THROTTLE CONTROL CABLE (See Fig. 30)

The throttle control has been preset at the factory and adjustment should not be necessary. Check adjustment as described below before loosening cable. If adjustment is necessary, proceed as follows:

- With engine not running, move throttle control lever from slow to choke position. Slowly move lever from choke to fast position.
- Check to see if hole in throttle lever and hole in speed control bracket are aligned.
- If holes are not aligned, loosen cable clamp screw and align the holes by inserting a pencil or a 1/4" drill bit through both holes.
- Pull throttle cable up to remove slack and tighten cable clamp screw. Remove alignment pencil or drill bit.

TO ADJUST CARBURETOR (See Fig. 31)

The carburetor has been preset at the factory and adjustment should not be necessary. However, minor adjustment may be required to compensate for differences in fuel, temperature, altitude or load. If the carburetor does need adjustment, proceed as follows:

In general, turning the adjusting needles **in** (clockwise) decreases the supply of fuel to the engine giving a leaner fuel/air mixture. Turning the adjusting needles **out** (counterclockwise) increases the supply of fuel to the engine giving a richer fuel/air mixture.

IMPORTANT: DAMAGE TO THE NEEDLES AND THE SEATS IN CARBURETOR MAY RESULT IF NEEDLE IS TURNED IN TOO TIGHT.

NOTE: The carburetor on this engine is low emission. It is equipped with an idle fuel adjusting needle with a limiter cap, which allows some adjustment within the limits allowed by the cap. Do not attempt to remove the limiter cap. The limiter cap cannot be removed without breaking the adjusting needle.

- Be sure you have a clean air filter and the throttle control cable is adjusted properly (see above).
- Start engine and allow to warm for five minutes. Make adjustments with engine running and shift/motion control lever in neutral (N) position.
- **Idle speed setting** - With throttle control lever in slow position, engine should idle at 1750 RPM. If engine idles too slow or fast, turn idle speed adjusting screw in or out until correct idle is attained.
- **Idle fuel needle setting** - With throttle control lever in slow position, turn idle fuel adjustment needle **in** (clockwise) until engine begins to die and then turn **out** (counterclockwise) until engine runs rough. Turn needle to a point midway between those two positions.
- Recheck idle speed. Readjust if necessary.

ACCELERATION TEST -

- Move throttle control lever from slow to fast position. If engine hesitates or dies, turn idle fuel adjusting needle **out** (counterclockwise) 1/8 turn. Repeat test and continue to adjust, if necessary, until engine accelerates smoothly.

High speed stop is factory adjusted. Do not adjust - damage may result.

IMPORTANT: NEVER TAMPER WITH THE ENGINE GOVERNOR, WHICH IS FACTORY SET FOR PROPER ENGINE SPEED. OVERSPEEDING THE ENGINE ABOVE THE FACTORY HIGH SPEED SETTING CAN BE DANGEROUS. IF YOU THINK THE ENGINE-GOVERNED HIGH SPEED NEEDS ADJUSTING, CONTACT YOUR NEAREST AUTHORIZED SERVICE CENTER/DEPARTMENT, WHICH HAS PROPER EQUIPMENT AND EXPERIENCE TO MAKE ANY NECESSARY ADJUSTMENTS.

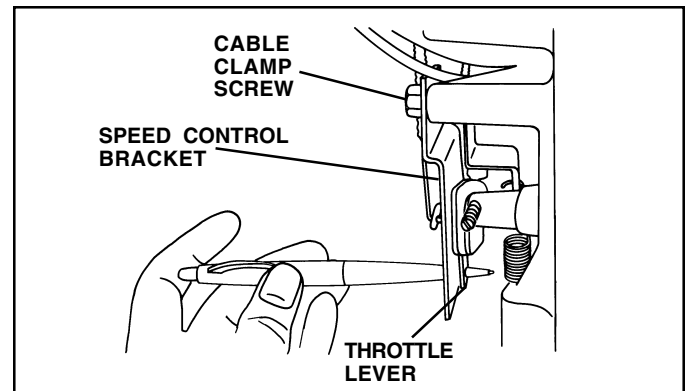

FIG. 30

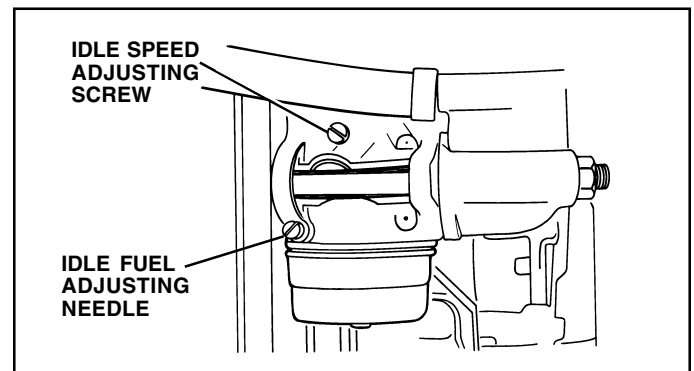

FIG. 31

STORAGE

Immediately prepare your tractor for storage at the end of the season or if the tractor will not be used for 30 days or more.



CAUTION: Never store the tractor with gasoline in the tank inside a building where fumes may reach an open flame or spark. Allow the engine to cool before storing in any enclosure.

TRACTOR

Remove mower from tractor for winter storage. When mower is to be stored for a period of time, clean it thoroughly, remove all dirt, grease, leaves, etc. Store in a clean, dry area.

- Clean entire tractor (See “CLEANING” in the Customer Responsibilities section of this manual).
- Inspect and replace belts, if necessary (See belt replacement instructions in the Service and Adjustments section of this manual).
- Lubricate as shown in the Customer Responsibilities section of this manual.
- Be sure that all nuts, bolts and screws are securely fastened. Inspect moving parts for damage, breakage and wear. Replace if necessary.
- Touch up all rusted or chipped paint surfaces; sand lightly before painting.

BATTERY

- Fully charge the battery for storage.
- After a period of time in storage, battery may require recharging.
- To help prevent corrosion and power leakage during long periods of storage, battery cables should be disconnected and battery cleaned thoroughly (see “TO CLEAN BATTERY AND TERMINALS” in the Customer Responsibilities section of this manual).
- After cleaning, leave cables disconnected and place cables where they cannot come in contact with battery terminals.

- If battery is removed from tractor for storage, do not store battery directly on concrete or damp surfaces.

ENGINE

FUEL SYSTEM

IMPORTANT: IT IS IMPORTANT TO PREVENT GUM DEPOSITS FROM FORMING IN ESSENTIAL FUEL SYSTEM PARTS SUCH AS CARBURETOR, FUEL FILTER, FUEL HOSE, OR TANK DURING STORAGE. ALSO, EXPERIENCE INDICATES THAT ALCOHOL BLENDED FUELS (CALLED GASOHOL OR USING ETHANOL OR METHANOL) CAN ATTRACT MOISTURE WHICH LEADS TO SEPARATION AND FORMATION OF ACIDS DURING STORAGE. ACIDIC GAS CAN DAMAGE THE FUEL SYSTEM OF AN ENGINE WHILE IN STORAGE.

- Drain the fuel tank.
- Start the engine and let it run until the fuel lines and carburetor are empty.
- Never use engine or carburetor cleaner products in the fuel tank or permanent damage may occur.
- Use fresh fuel next season.

NOTE: Fuel stabilizer is an acceptable alternative in minimizing the formation of fuel gum deposits during storage. Add stabilizer to gasoline in fuel tank or storage container. Always follow the mix ratio found on stabilizer container. Run engine at least 10 minutes after adding stabilizer to allow the stabilizer to reach the carburetor. Do not drain the gas tank and carburetor if using fuel stabilizer.

ENGINE OIL

Drain oil (with engine warm) and replace with clean engine oil. (See “ENGINE” in the Customer Responsibilities section of this manual).

CYLINDER(S)

- Remove spark plug(s).
- Pour one ounce of oil through spark plug hole(s) into cylinder(s).
- Turn ignition key to “START” position for a few seconds to distribute oil.
- Replace with new spark plug(s).

OTHER

- Do not store gasoline from one season to another.
- Replace your gasoline can if your can starts to rust. Rust and/or dirt in your gasoline will cause problems.
- If possible, store your tractor indoors and cover it to give protection from dust and dirt.
- Cover your tractor with a suitable protective cover that does not retain moisture. Do not use plastic. Plastic cannot breathe which allows condensation to form and will cause your tractor to rust.

IMPORTANT: NEVER COVER TRACTOR WHILE ENGINE AND EXHAUST ARE STILL WARM.

TROUBLESHOOTING POINTS

PROBLEM	CAUSE	CORRECTION
Will not start	<ol style="list-style-type: none"> 1. Out of fuel. 2. Engine not "CHOKED" properly. 3. Engine flooded. 4. Bad spark plug. 5. Dirty air filter. 6. Dirty fuel filter. 7. Water in fuel. 8. Loose or damaged wiring. 9. Carburetor out of adjustment. 10. Engine valves out of adjustment. 	<ol style="list-style-type: none"> 1. Fill fuel tank. 2. See "TO START ENGINE" in Operation section. 3. Wait several minutes before attempting to start. 4. Replace spark plug. 5. Clean/replace air filter. 6. Replace fuel filter. 7. Drain fuel tank and carburetor, refill tank with fresh gasoline and replace fuel filter. 8. Check all wiring. 9. See "To Adjust Carburetor" in Service Adjustments section. 10. Contact an authorized service center/department.
Hard to start	<ol style="list-style-type: none"> 1. Dirty air filter. 2. Bad spark plug. 3. Weak or dead battery. 4. Dirty fuel filter. 5. Stale or dirty fuel. 6. Loose or damaged wiring. 7. Carburetor out of adjustment. 8. Engine valves out of adjustment. 	<ol style="list-style-type: none"> 1. Clean/replace air filter. 2. Replace spark plug. 3. Recharge or replace battery. 4. Replace fuel filter. 5. Drain fuel tank and refill with fresh gasoline. 6. Check all wiring. 7. See "To Adjust Carburetor" in Service Adjustments section. 8. Contact an authorized service center/department.
Engine will not turn over	<ol style="list-style-type: none"> 1. Brake pedal not depressed. 2. Attachment clutch is engaged. 3. Weak or dead battery. 4. Blown fuse. 5. Corroded battery terminals. 6. Loose or damaged wiring. 7. Faulty ignition switch. 8. Faulty solenoid or starter. 9. Faulty operator presence switch(es). 	<ol style="list-style-type: none"> 1. Depress brake pedal. 2. Disengage attachment clutch. 3. Recharge or replace battery. 4. Replace fuse. 5. Clean battery terminals. 6. Check all wiring. 7. Check/replace ignition switch. 8. Check/replace solenoid or starter. 9. Contact an authorized service center/department.
Engine clicks but will not start	<ol style="list-style-type: none"> 1. Weak or dead battery. 2. Corroded battery terminals. 3. Loose or damaged wiring. 4. Faulty solenoid or starter. 	<ol style="list-style-type: none"> 1. Recharge or replace battery. 2. Clean battery terminals. 3. Check all wiring. 4. Check/replace solenoid or starter.
Loss of power	<ol style="list-style-type: none"> 1. Cutting too much grass/too fast. 2. Throttle in "CHOKE" position. 3. Build-up of grass, leaves and trash under mower. 4. Dirty air filter. 5. Low oil level/dirty oil. 6. Faulty spark plug. 7. Dirty fuel filter. 8. Stale or dirty fuel. 9. Water in fuel. 10. Spark plug wire loose. 11. Dirty engine air screen/fins. 12. Dirty/clogged muffler. 13. Loose or damaged wiring. 14. Carburetor out of adjustment. 15. Engine valves out of adjustment. 	<ol style="list-style-type: none"> 1. Set in "Higher Cut" position/reduce speed. 2. Adjust throttle control. 3. Clean underside of mower housing. 4. Clean/replace air filter. 5. Check oil level/change oil. 6. Clean and regap or change spark plug. 7. Replace fuel filter. 8. Drain fuel tank and refill with fresh gasoline. 9. Drain fuel tank and carburetor, refill tank with fresh gasoline and replace fuel filter. 10. Connect and tighten spark plug wire. 11. Clean engine air screen/fins. 12. Clean/replace muffler. 13. Check all wiring. 14. See "To Adjust Carburetor" in Service Adjustments section. 15. Contact an authorized service center/department.
Excessive vibration	<ol style="list-style-type: none"> 1. Worn, bent or loose blade. 2. Bent blade mandrel. 3. Loose/damaged part(s). 	<ol style="list-style-type: none"> 1. Replace blade. Tighten blade bolt. 2. Replace blade mandrel. 3. Tighten loose part(s). Replace damaged parts.

TROUBLESHOOTING POINTS

PROBLEM	CAUSE	CORRECTION
Engine continues to run when operator leaves seat with attachment clutch engaged	<ol style="list-style-type: none"> 1. Faulty operator-safety presence control system. 	<ol style="list-style-type: none"> 1. Check wiring, switches and connections. If not corrected, contact an authorized service center/ department.
Poor cut - uneven	<ol style="list-style-type: none"> 1. Worn, bent or loose blade. 2. Mower deck not level. 3. Buildup of grass, leaves, and trash under mower. 4. Bent blade mandrel. 5. Clogged mower deck vent holes from buildup of grass, leaves, and trash around mandrels. 	<ol style="list-style-type: none"> 1. Replace blade. Tighten blade bolt. 2. Level mower deck. 3. Clean underside of mower housing. 4. Replace blade mandrel. 5. Clean around mandrels to open vent holes.
Mower blades will not rotate	<ol style="list-style-type: none"> 1. Obstruction in clutch mechanism. 2. Worn/damaged mower drive belt. 3. Frozen idler pulley. 4. Frozen blade mandrel. 	<ol style="list-style-type: none"> 1. Remove obstruction. 2. Replace mower drive belt. 3. Replace idler pulley. 4. Replace blade mandrel.
Poor grass discharge	<ol style="list-style-type: none"> 1. Engine speed too slow. 2. Travel speed too fast. 3. Wet grass. 4. Mower deck not level. 5. Low/uneven tire air pressure. 6. Worn, bent or loose blade. 7. Buildup of grass, leaves and trash under mower. 8. Mower drive belt worn. 9. Blades improperly installed. 10. Improper blades used. 11. Clogged mower deck vent holes from buildup of grass, leaves, and trash around mandrels. 	<ol style="list-style-type: none"> 1. Place throttle control in "FAST" position. 2. Shift to slower speed. 3. Allow grass to dry before mowing. 4. Level mower deck. 5. Check tires for proper air pressure. 6. Replace/sharpen blade. Tighten blade bolt. 7. Clean underside of mower housing. 8. Replace mower drive belt. 9. Reinstall blades sharp edge down. 10. Replace with blades listed in this manual. 11. Clean around mandrels to open vent holes.
Headlight(s) not working (if so equipped)	<ol style="list-style-type: none"> 1. Switch is "OFF". 2. Bulb(s) or lamp(s) burned out. 3. Faulty light switch. 4. Loose or damaged wiring. 5. Blown fuse. 	<ol style="list-style-type: none"> 1. Turn switch "ON". 2. Replace bulb(s) or lamp(s). 3. Check/replace light switch. 4. Check wiring and connections. 5. Replace fuse.
Battery will not charge	<ol style="list-style-type: none"> 1. Bad battery cell(s). 2. Poor cable connections. 3. Faulty regulator (if so equipped). 4. Faulty alternator. 	<ol style="list-style-type: none"> 1. Replace battery. 2. Check/clean all connections. 3. Replace regulator. 4. Replace alternator.
Loss of drive	<ol style="list-style-type: none"> 1. Freewheel control in "disengaged" position. 2. Motion drive belt worn, damaged, or broken. 3. Air trapped in transmission during shipment or servicing. 	<ol style="list-style-type: none"> 1. Place freewheel control in "engaged" position. 2. Replace motion drive belt. 3. Purge transmission.
Engine "backfires" when turning engine "OFF"	<ol style="list-style-type: none"> 1. Engine throttle control not set at "SLOW" position for 30 seconds before stopping engine. 	<ol style="list-style-type: none"> 1. Move throttle control to "SLOW" position and allow to idle for 30 seconds before stopping engine.

TRACTOR - - MODEL NUMBER 944.600952

SCHEMATIC

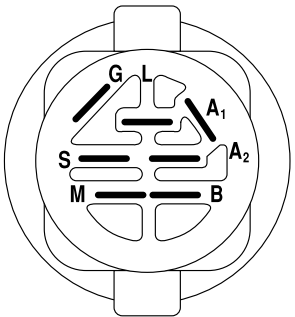
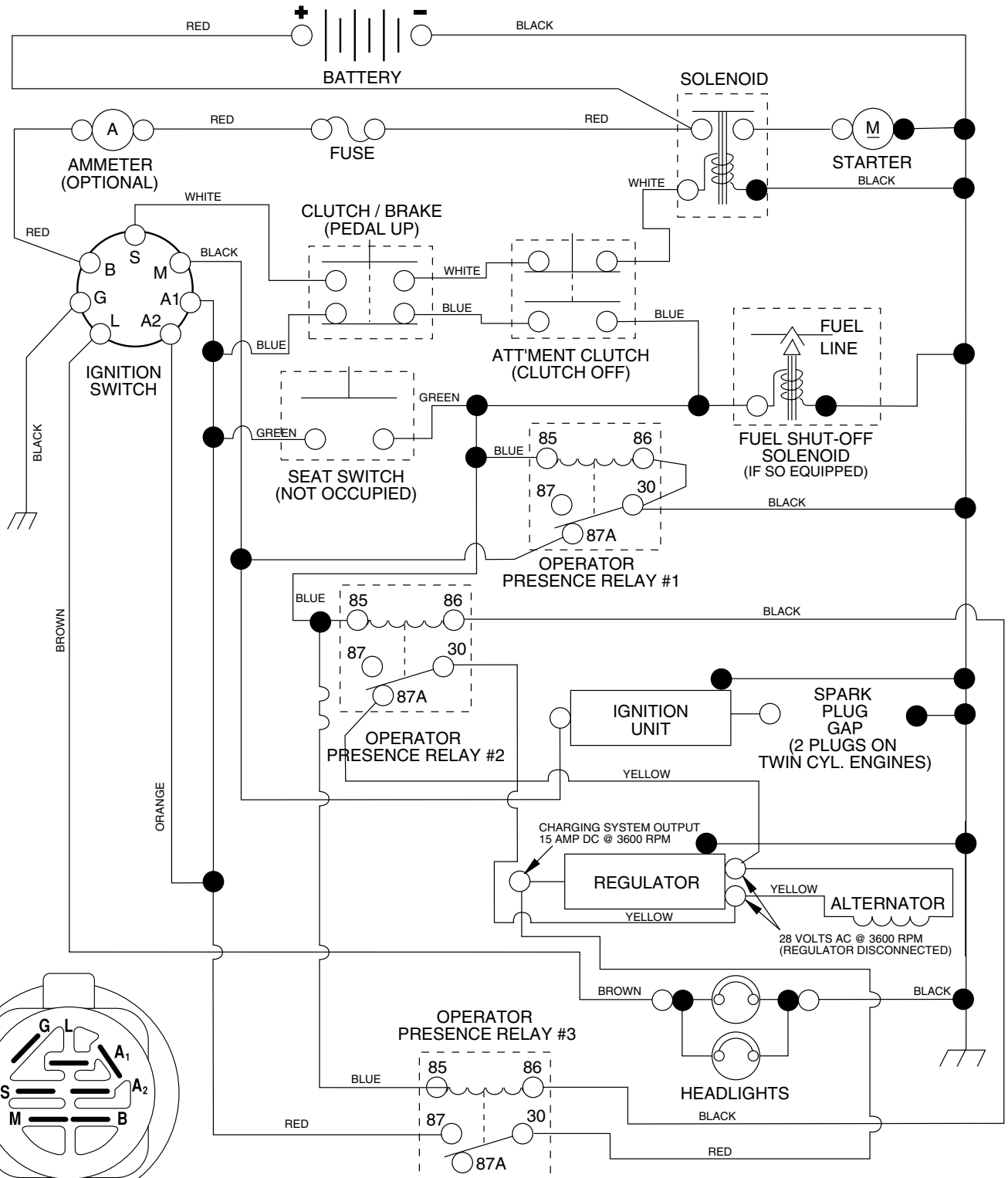

IGNITION SWITCH

POSITION	CIRCUIT	"MAKE"
OFF	M+G+A1	NONE
RUN/LIGHT	B+A1	A2+L
RUN	B+A1	NONE
START	B + S + A1	NONE

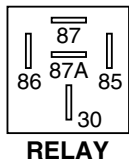

●
NON-REMOVABLE CONNECTIONS

○
REMOVABLE CONNECTIONS

WIRING INSULATED CLIPS

NOTE: IF WIRING INSULATED CLIPS WERE REMOVED FOR SERVICING OF UNIT, THEY SHOULD BE REPLACED TO PROPERLY SECURE YOUR WIRING.

REPAIR PARTS

TRACTOR - - MODEL NUMBER 944.600952

ELECTRICAL

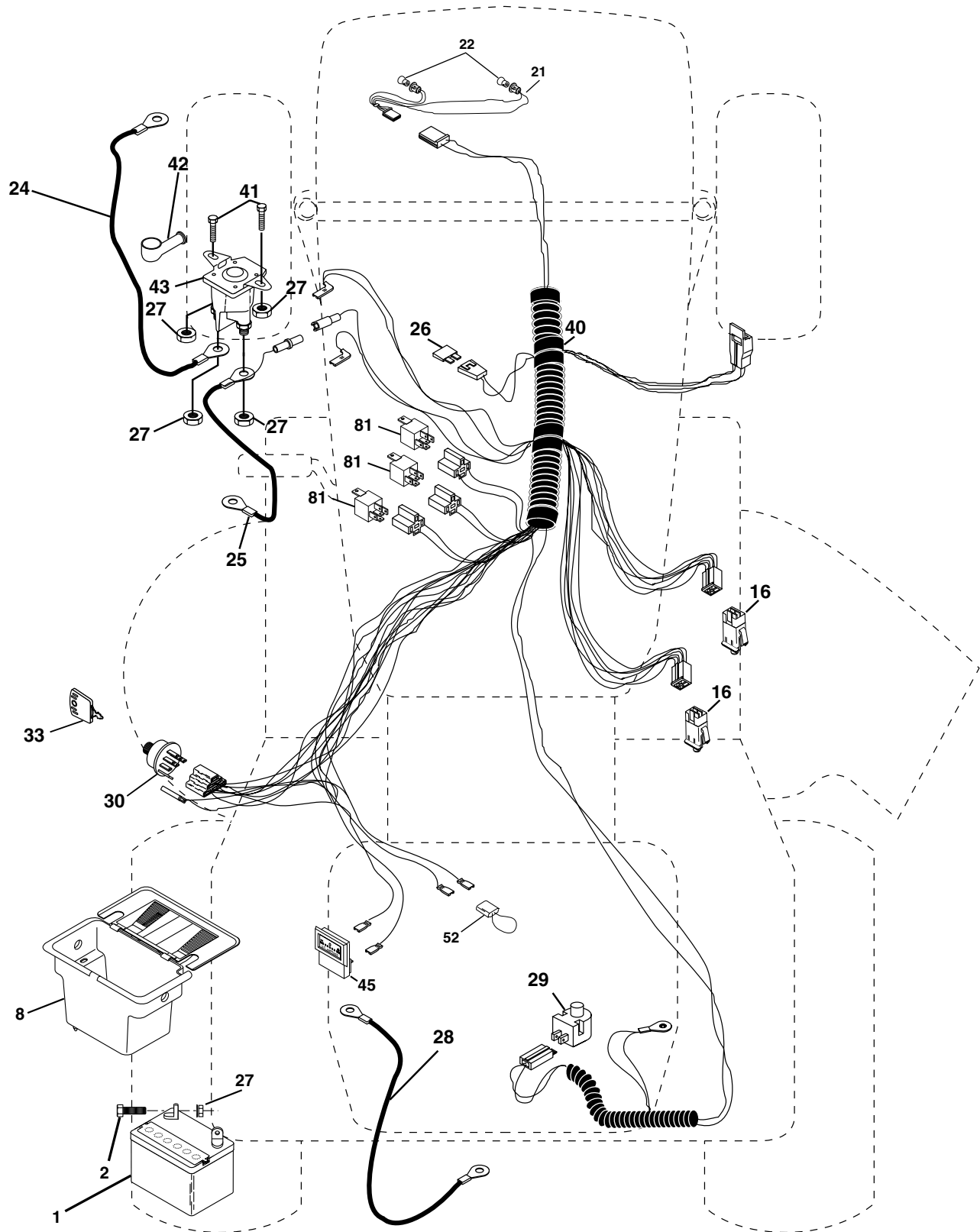

REPAIR PARTS

TRACTOR - - MODEL NUMBER 944.600952

ELECTRICAL

KEY NO.	PART NO.	DESCRIPTION
1	163465	Battery
2	74760412	Bolt Hex Hd 1/4-20unc X 3/4
8	156417	Case Battery Mech Hinge
16	161343	Switch Interlock N Opn/N Opn
21	166182	Harness Asm Light W/4152J
22	4152J	Bulb Light #1156
24	4799J	Cable Battery 6 Ga 11"red
25	146147	Cable Battery 6 Ga w/16 wire,red
26	175158	Fuse 20 AMP
27	73510400	Nut Kep Hex 1/4-20
28	4207J	Cable Ground 6 Ga 12" black
29	160784	Switch Plunger Normal Op Olive
30	175566	Switch Ign
33	140403	Key Ign
40	178439	Harness Ign
41	71110408	Bolt Blk Fin Hex 1/4-20unc X 1/2
42	131563	Cover Terminal Red
43	175141	Solenoid
45	122822X	Ammeter
52	141940	Protection Wire Loop (Hourmeter)
81	109748X	Relay Asm

NOTE: All component dimensions give in U.S. inches
1 inch = 25.4 mm.

REPAIR PARTS

TRACTOR - - MODEL NUMBER 944.600952

CHASSIS AND ENCLOSURES

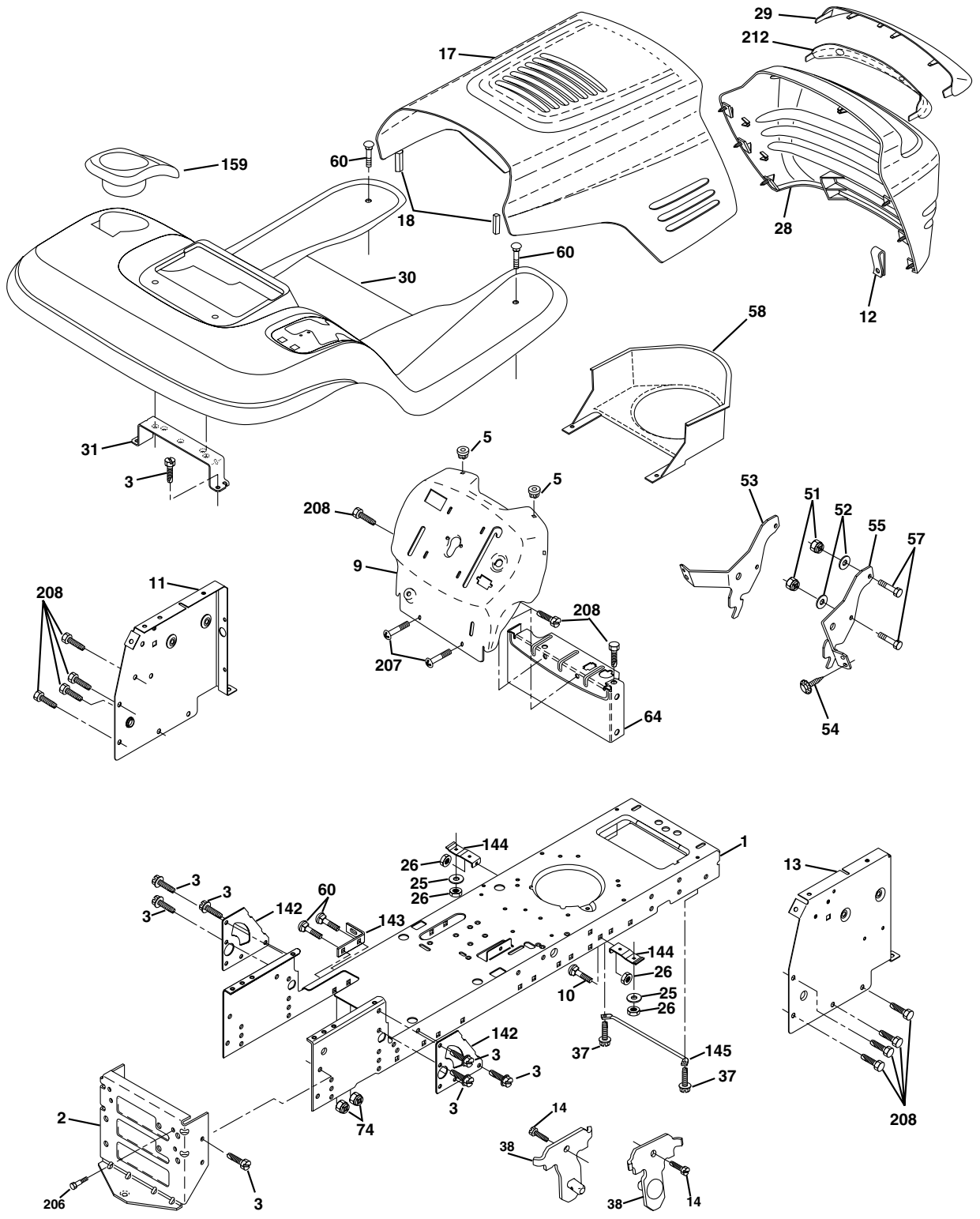

REPAIR PARTS

TRACTOR - - MODEL NUMBER 944.600952

CHASSIS AND ENCLOSURES

KEY NO.	PART NO.	DESCRIPTION
1	174619	Chassis
2	174554	Drawbar
3	17060612	Screw 3/8-16x3/4
5	155272	Bumper Hood/Dash
9	168337X011	Dash P/L M, W/AMM N/HM
10	STD533710	Bolt Carriage 3/8-16 x 1
11	155927	Panel Dash Lh
12	145660	Clip Tinnerman Grille P/L
13	172108	Panel Dash Rh
14	17490608	Screw Thdrol 3/8-16 x 1/2
17	144983X558	Hood
18	126938X	Bumper Hood
25	19131312	Washer 13/32 X 13/16 X 12 Ga
26	STD541437	Nut Lock Hex W/Ins 3/8-16 Unc
28	156725X558	Grille/Lens Asm
29	155217X599	Lens Grille
30	164919X558	Fender Footrest STLT Pnt
31	139976	Bracket Support Fender
37	17490508	Screw Thdrol 6/16-18 x 1/2 TYT
38	175710	Bracket, Asm. Pivot, Mower Rear
51	73800400	Nut Lock Hex W/Ins 1/4-20
52	19091416	Washer 9/32 x 7/8 x 16 Ga.
53	145201	Bracket Grille Pick off L.H.
54	161464	Screw Hex Wshd 8-18 x 7/8
55	145202	Bracket Grille Pickoff R.H.
57	74780412	Bolt Hex 1/4-20 x 3/4
58	150127	Duct Air Engine PL/LT
60	STD533707	Bolt Rdhd Sqnk 3/8-16unc x 3/4
64	154798	Dash Lower STLT
74	STD541437	Nut Crownlock 3/8-16 UNC
142	165867	Plate Reinforcement STLT
143	154966	Bracket Swaybar Chassis
144	175582	Bracket Pnt Footrest STLT
145	156524	Rod Pivot Chassis/Hood
159	155123X428	Cupholder STLT Black
206	170165	Bolt Shoulder 5/16-18 UNC
207	17670508	Screw Thdrol 5/16-18 x 1/2
208	17670608	Screw Thdrol 3/8-16 x 1/2
212	165919	Insert Lens Reflective
--	5479J	Plug Button

NOTE: All component dimensions given in U.S. inches
1 inch = 25.4 mm

REPAIR PARTS

TRACTOR - - MODEL NUMBER 944.600952

DRIVE

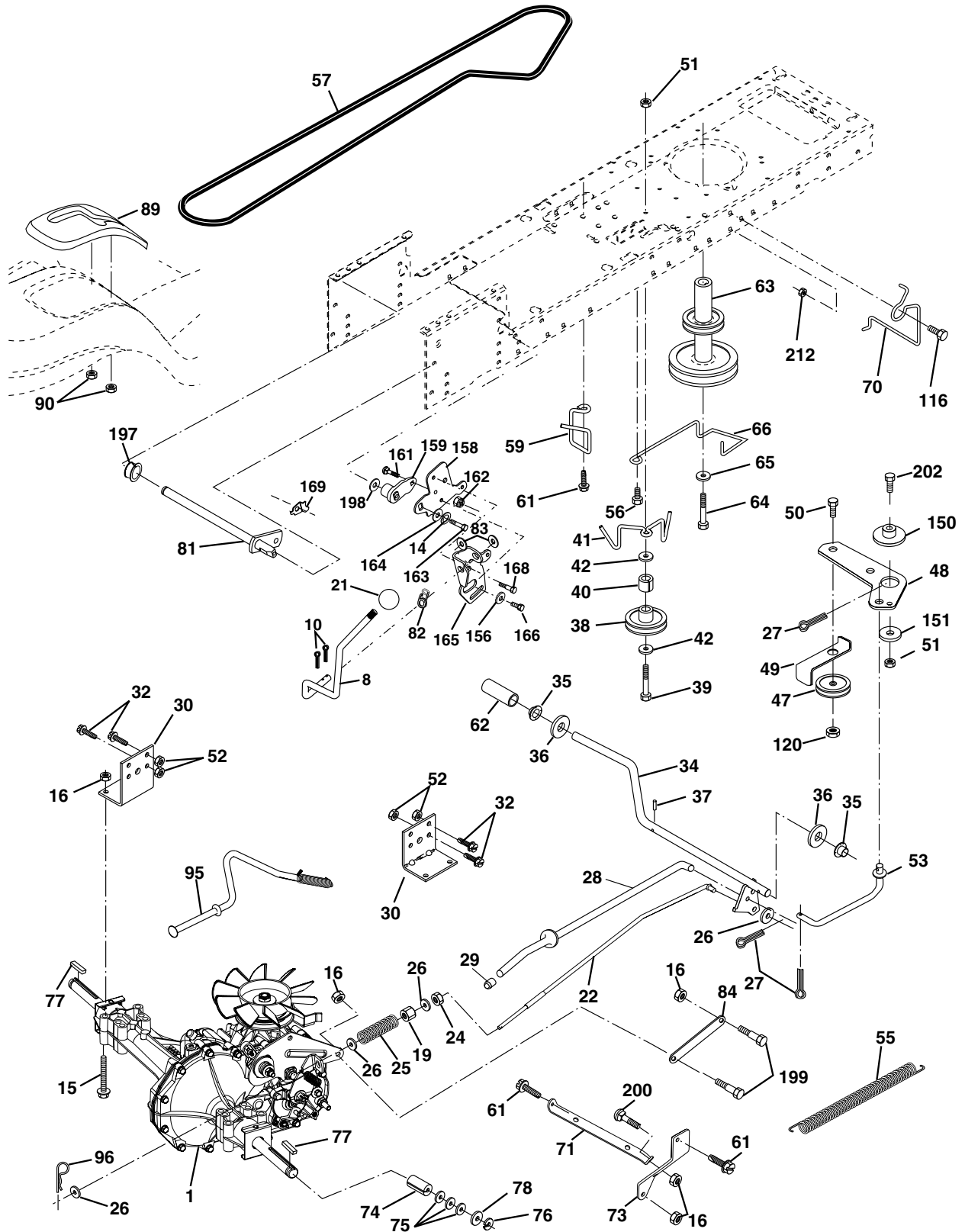

REPAIR PARTS

TRACTOR - - MODEL NUMBER 944.600952

DRIVE

KEY NO.	PART NO.	DESCRIPTION	KEY NO.	PART NO.	DESCRIPTION
1	-----	Transaxle (See Breakdown) Hydro Gear Model 314-0510	65	STD551143	Washer
8	165866	Rod Shift	66	154778	Keeper Belt Engine
10	STD561210	Pin Cotter 1/8 x 1 CAD	70	134683	Keeper Belt Engine
14	10040400	Washer Lock Hvy. Helical 1/4	71	169183	Strap Torque Lh
15	74490544	Bolt, Hex FLGHD 5/16-18 Gr. 5	72	19132012	Washer 13/32 x 1-1/4 x 12 Gauge
16	STD541431	Nut Lock Hex W/Ins 5/16-18 Unc P	73	169182	Strap Torque Rh
19	STD541437	Nut Lock Hex W/Wsh 3/8-16 Unc	74	137057	Spacer, Axle
21	130564	Knob, Deluxe 1/2-13	75	121749X	Washer 25/32 x 1-1/4 x 16 Gauge
22	169498	Rod, Brake	76	STD581075	E-Ring
24	STD541273	Nut	77	123583X	Key, Square
25	106888X	Spring, Brake Rod	78	121748X	Washer 25/32 x 1-5/8 x 16 Gauge
26	STD551037	Washer	81	165596	Shaft Asm. Cross
27	STD561210	Pin Cotter 1/8 x 3/4 CAD.	82	165711	Spring Torsion
28	175765	Rod, Parking Brake	83	19171216	Washer 17/32 x 3/4 x 16 Ga.
29	71673	Cap, Parking Brake	84	169594	Link, Transaxle
30	169592	Bracket, Transaxle	89	164890X428	Console, Shift
32	STD523107	Bolt Hex Hd 5/16-18 Unc x 3/4	90	124346X	Nut Self Thd Wsh-Hd 1/4 Zinc
34	175578	Shaft, Foot Pedal	95	170201	Control Asm Bypass Hydro
35	120183X	Bearing, Nylon	96	STD624003	Retainer Spring 1" Zinc/Cad
36	STD551062	Washer	116	72140608	Bolt Rdhd Sq. Neck 3/8-16 x 1.0
37	STD571810	Pin, Roll	120	73900600	Nut Lock Flg 3/8-16
38	165936	Pulley, Idler, Flat	150	175456	Spacer Retainer
39	74760648	Bolt	151	19133210	Washer 13/32 x 2 x 10 Ga.
40	175461	Spacer, Split	156	166002	Washer Srrted 5/16 ID x 1 x .125
41	175556	Keeper, Belt	158	165589	Bracket Shift Mount
42	19131312	Washer 13/32 x 13/16 x 12 Gauge	159	165494	Hub Tapered Flange Shift LT
47	127783	Pulley, Idler, V-Groove	161	72140406	Bolt Rdhd Sqnk 1/4-20 x 3/4 Gr. 5
48	154407	Bellcrank Clutch Grnd Drv STL	162	73680400	Nut Crownlock 1/4-20 Unc
49	123205X	Retainer, Belt	163	74780416	Bolt Hex Fin 1/4-20 Unc x 1 Gr. 5
50	STD523715	Bolt	164	19091010	Washer 5/8 x .281 x 10 Ga.
51	STD541437	Nut Crownlock 3/8-16 UNC	165	165623	Bracket Pivot Lever
52	STD541431	Nut Crownlock 5/16-18 UNC	166	166880	Screw 5/16-18 x 5/8
53	105710X	Link, Clutch	168	165492	Bolt Shoulder 5/16-18 x .561
55	105709X	Spring, Return, Clutch	169	165580	Plate Fastening LT
56	17060616	Screw 3/8-16 x 1	197	169613	Nyliner Snap-In 5/8" ID
57	140294	V-Belt, Ground Drive	198	169593	Washer Nyl 7/8 ID x .105"
59	169691	Keeper, Center Span	199	169612	Bolt Shoulder 5/16-18 UNC
61	17060612	Screw 3/8-16 x 3/4	200	72140508	Bolt Rdhd Sqnk 5/16-18 UNC x 1
62	8883R	Cover, Pedal	202	72110614	Bolt Carr Sh 3/8-16 x 1-3/4 Gr. 5
63	175410	Pulley, Engine	212	145212	Nut Hex Flg. Lock
64	71170764	Bolt, Hex			

NOTE: All component dimensions given in U.S. inches
1 inch = 25.4 mm

REPAIR PARTS

TRACTOR - - MODEL NUMBER 944.600952

STEERING ASSEMBLY

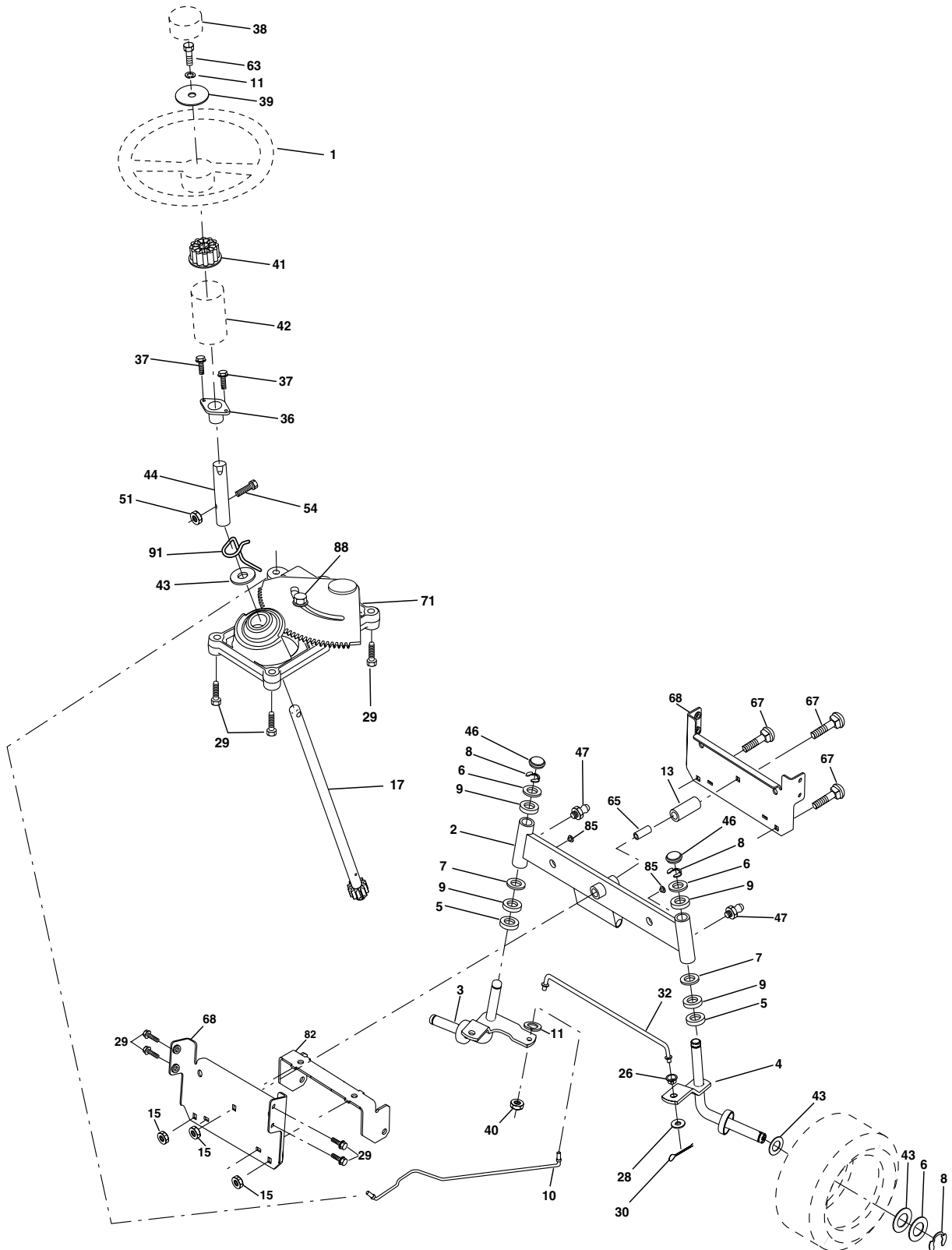

REPAIR PARTS

TRACTOR - - MODEL NUMBER 944.600952

STEERING ASSEMBLY

KEY NO.	PART NO.	DESCRIPTION
1	139768	Wheel Steering
2	154427	Axle Asm STMP Dropped STL
3	169840	Spindle Asm LH
4	169839	Spindle Asm RH
5	6266H	Bearing Race Thrust Harden
6	121748X	Washer 25/32 X 1-5/8 X 16 Ga
7	19272016	Washer 27/32 X 1-1/4 X 16 Ga
8	12000029	Ring Klip #t5304-75
9	3366R	Bearing Col Strg Blk
10	175121	Link Drag
11	STD551137	Washer Lock Hvy Hlcl Spr 3/8
13	136518	Spacer Brg Axle Front
15	145212	Nut Hex Flange Lock
17	177876	Shaft Asm Strg
26	126847X	Bushing Link Drag Blk LR
28	19131416	Washer 13/32 X 7/8 X 16 Ga
29	17060612	Screw 3/8-16x3/4
30	STD561210	Pin Cotter 1/8 X 3/4 Cad
32	130465	Rod Tie Wire Form 19 75 Mech
36	155099	Bushing Strg
37	152927	Screw
38	139769	Insert Cap Strg Wh Au
39	19133812	Washer 13/32 X 2-3/8 X 12 Ga
40	STD541537	Lock nut
41	100711L	Adaptor Wheel Strg
42	145054X428	Boot Steering Shaft
43	121749X	Washer 25/32 X 1 1/4 X 16 Ga
44	153720	Extension Steering Shaft LR/LT
46	121232X	Cap Spindle Fr Top Blk
47	6855M	Fitting Grease
51	STD541431	Nut Lock Hex w/Ins 5/16-18
54	STD523112	Bolt Fin Hex 5/16-18 Unc x 1-1/4
63	STD523710	Bolt Fin Hex 3/8-16unc x 1 Gr. 5
65	160367	Spacer Brace Axle
67	72140618	Bolt, Rdhd Sq 3/8-16 UNC x 2-1/4
68	169827	Axle, Brace
71	175146	Steering Asm.
82	169835	Bracket Susp Chassis Front
85	133835	Fastener Christmas Tree
88	175118	Bolt Shoulder 7/16-20 Unc
91	175553	Clip

NOTE: All component dimensions given in U.S. inches
1 inch = 25.4 mm

REPAIR PARTS

TRACTOR - - MODEL NUMBER 944.600952

SEAT ASSEMBLY

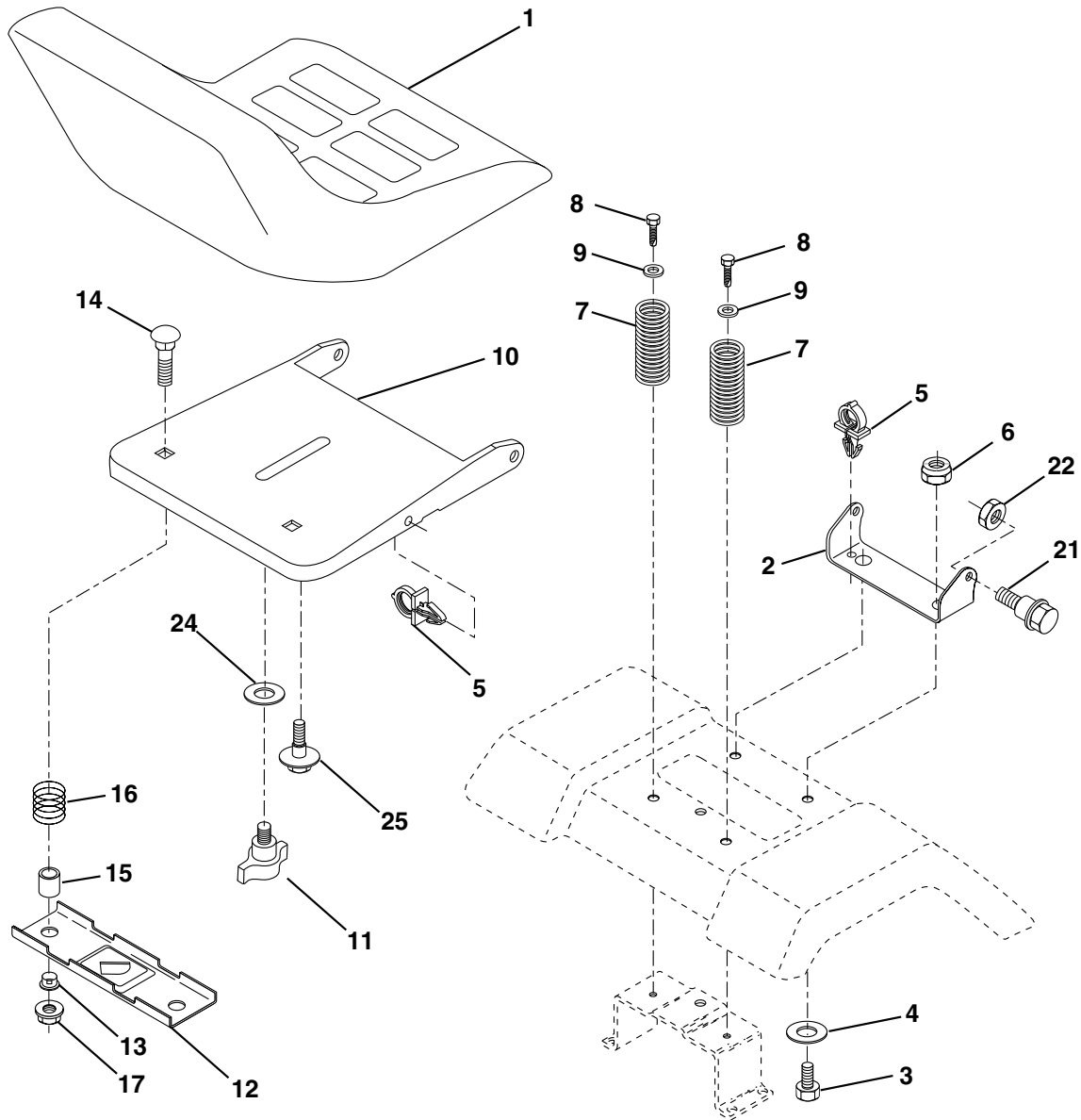

KEY NO.	PART NO.	DESCRIPTION
1	140123	Seat
2	140551	Bracket Pivot Seat 8 720
3	71110616	Bolt Fin Hex 3/8-16unc X 1
4	19131610	Washer 13/32 X 1 X 10 Ga
5	145006	Clip Push-In
6	STD541437	Nut Hex w/Ins. 3/8-16 Unc
7	124181X	Spring Seat Cprsn 2 250 Blk Zi
8	17000616	Screw 3/8-16 X 1-1/2
9	19131614	Washer 13/32 X 1 X 14 Ga.
10	174894	Pan Seat
11	166369	Knob Seat
12	121246X	Bracket Mounting Switch

KEY NO.	PART NO.	DESCRIPTION
13	121248X	Bushing Snap Blk Nyl 50 Id
14	72050412	Bolt Rdhd Sqnk 1/4-20x1-1/2
15	134300	Spacer Split 28x 96 Yel Zinc
16	121250X	Spring Cprsn 1 27 Blk Pnt
17	123976X	Nut Lock 1/4 Lge Flg Gr 5 Zinc
21	171852	Bolt Shoulder 5/16-18 Unc
22	STD541431	Nut Hex Lock W/Ins 5/16-18
24	19171912	Washer 17/32 X 1-3/16 X 12 Ga.
25	127018X	Bolt Shoulder 5/16-18 X 62

NOTE: All component dimensions given in U.S. inches
1 inch = 25.4 mm

REPAIR PARTS

TRACTOR - - MODEL NUMBER 944.600952

DECALS

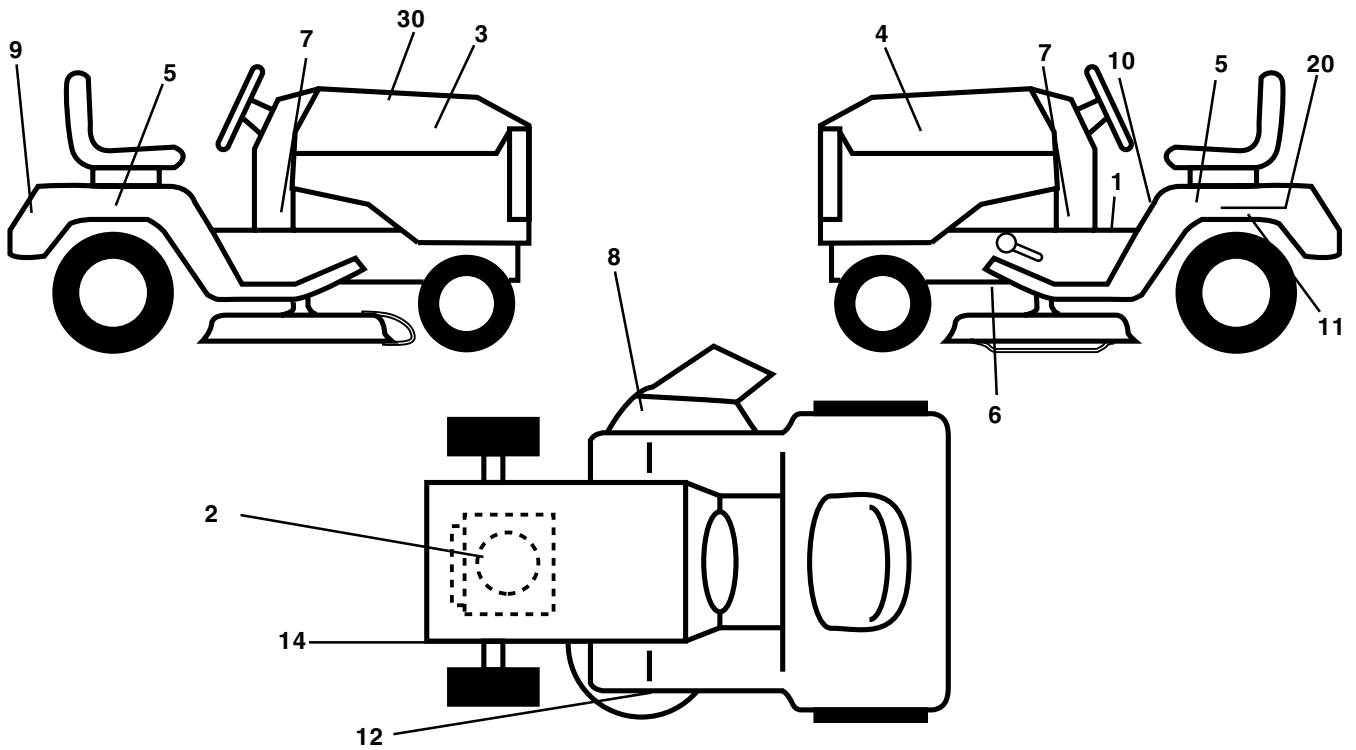

KEY NO.	PART NO.	DESCRIPTION
1	157032	Decal Fend STLT Oper
2	171736	Decal Engine
3	171698	Decal Hood RH
4	171699	Decal Hood LH
5	163205	Decal Fender Sd Wht Rad Auto
6	146046	Decal V Belt Drive Sch
7	171710	Decal Dash Pnl
8	137259	Decal Warning Multi-Language
9	163204	Decal Craftsman
10	157140	Decal Fender Danger Eng/Fr

KEY NO.	PART NO.	DESCRIPTION
11	138047	Decal Battery
12	166887	Decal Deck EZ3
14	160396	Decal V-Belt Schematic
20	149517	Decal Bat Dan/Psn
--	172270	Decal Replacement Parts
--	169210	Decal Cntrl Movement HYD Lt
--	165800X428	Pad Footrest LH STLT
--	165799X428	Pad Footrest RH STLT
--	138311	Decal Handle Lft Height Adjust
--	179042	Manual Owner's (English)
--	179043	Manual Owner's (French)

WHEELS & TIRES

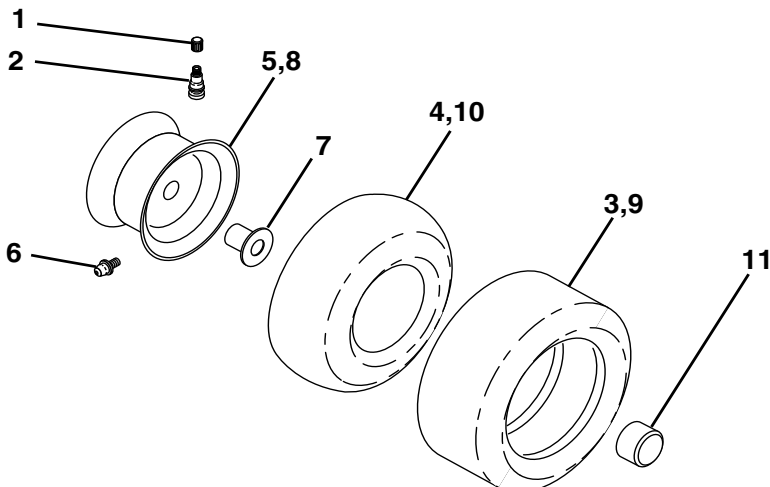

KEY NO.	PART NO.	DESCRIPTION
1	59192	Cap Valve Tire
2	65139	Stem Valve
3	106222X	Tire F Ts 15 X 6 0 - 6 Service
4	59904	Tube Front (Service Item Only)
5	106732X427	Rim Asm 6"front Service
6	278H	Fitting Grease (Front Wheel Only)
7	9040H	Bearing Flange (Front Wheel Only)
8	106108X427	Rim Asm 8"rear Service
9	122082X	Tire R Ts 20x10-8 C Service
10	7152J	Tube Rear (Service Item Only)
11	104757X	Cap Axle Blk 1 50 X 1 00
--	144334	Sealant, Tire (10 oz. Tube)

NOTE: All component dimensions given in U.S. inches
1 inch = 25.4 mm

REPAIR PARTS

TRACTOR - - MODEL NUMBER 944.600952

ENGINE

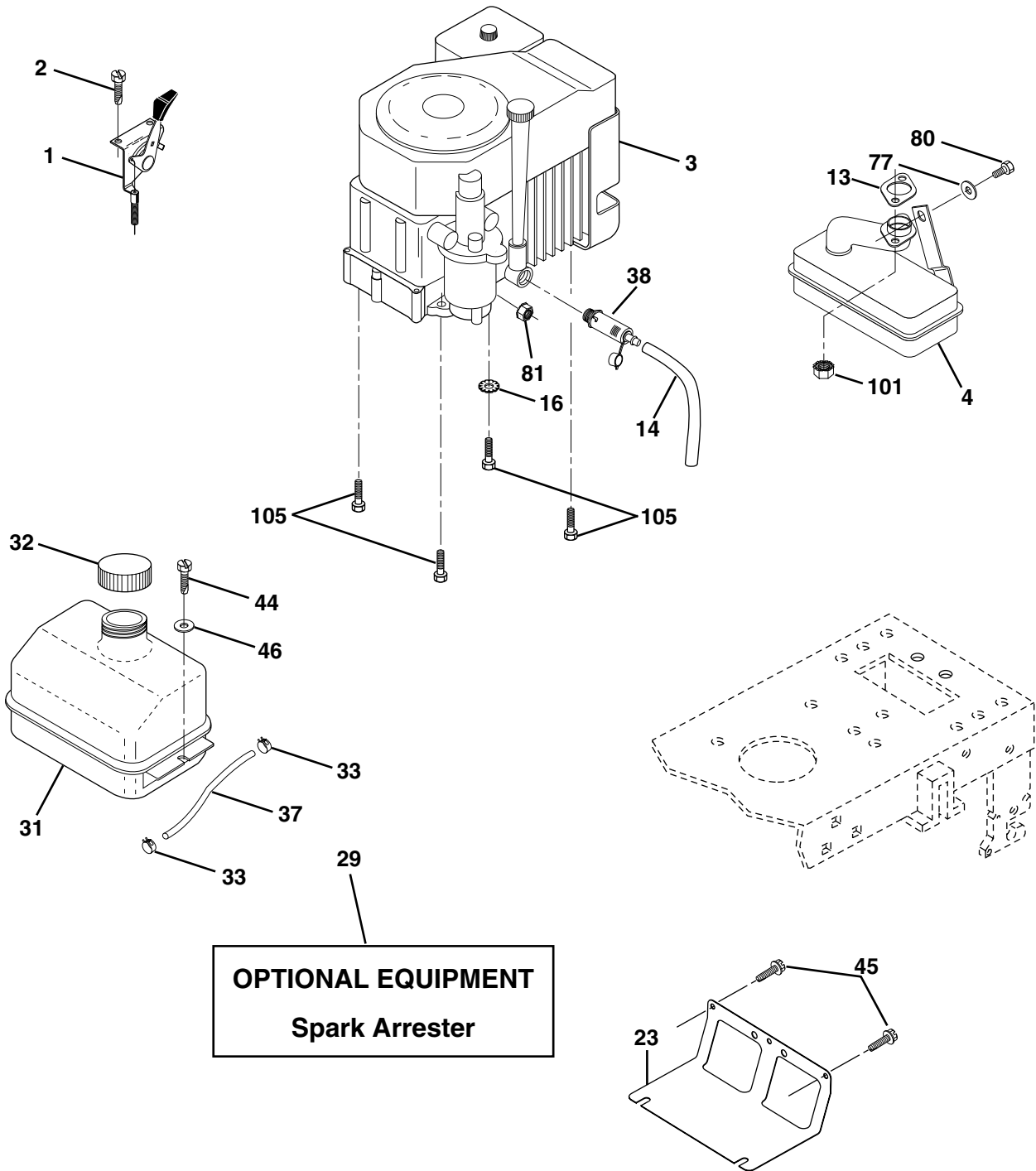

REPAIR PARTS

TRACTOR - - MODEL NUMBER 944.600952

ENGINE

KEY NO.	PART NO.	DESCRIPTION
1	170548	Control Th/ch Pdl
2	17720410	Screw Hex Thd Cut 1/4-20x5/8 T
3	-----	Engine, Kohler Model CV490-27508 (See Engine Breakdown)
4	174667	Muffler
13	12-041-03	Gasket Eng
14	148456	Tube Drain Oil
16	STD551237	Washer Lock Ext Tooth 3/8
23	169837	Shield Brn/Dbr Guard
29	137180	Kit Spark Arrestor (Flat Scrn)
31	109202X	Tank Fuel Front 1 25
32	158990	Cap Asm Fuel Vented
33	123487X	Clamp Hose Black
37	137040	Line Fuel 20"
38	148315	Plug Oil Drain
40	124028X	Bushing Snap Nyl Blk Fuel Line
44	17670412	Screw Hexwsh Thdrol 1/4-20x3/4
45	17000612	Screw
46	19091416	Washer 9/32 X 7/8 X 16 Ga
77	STD551031	Washer 5/16 x 3/4 x 16 Ga.
80	STD523105	Bolt Hex Hd 5/16-18 x 1/2
81	STD541425	Nut Flange 1/4-20 Starter Nut
101	M73030800	Nut Flange M8-1.25
105	17120616	Screw 3/8-16 x 1

NOTE: All component dimensions given in U.S. inches
1 inch = 25.4 mm

REPAIR PARTS

TRACTOR - - MODEL NUMBER 944.600952

MOWER DECK

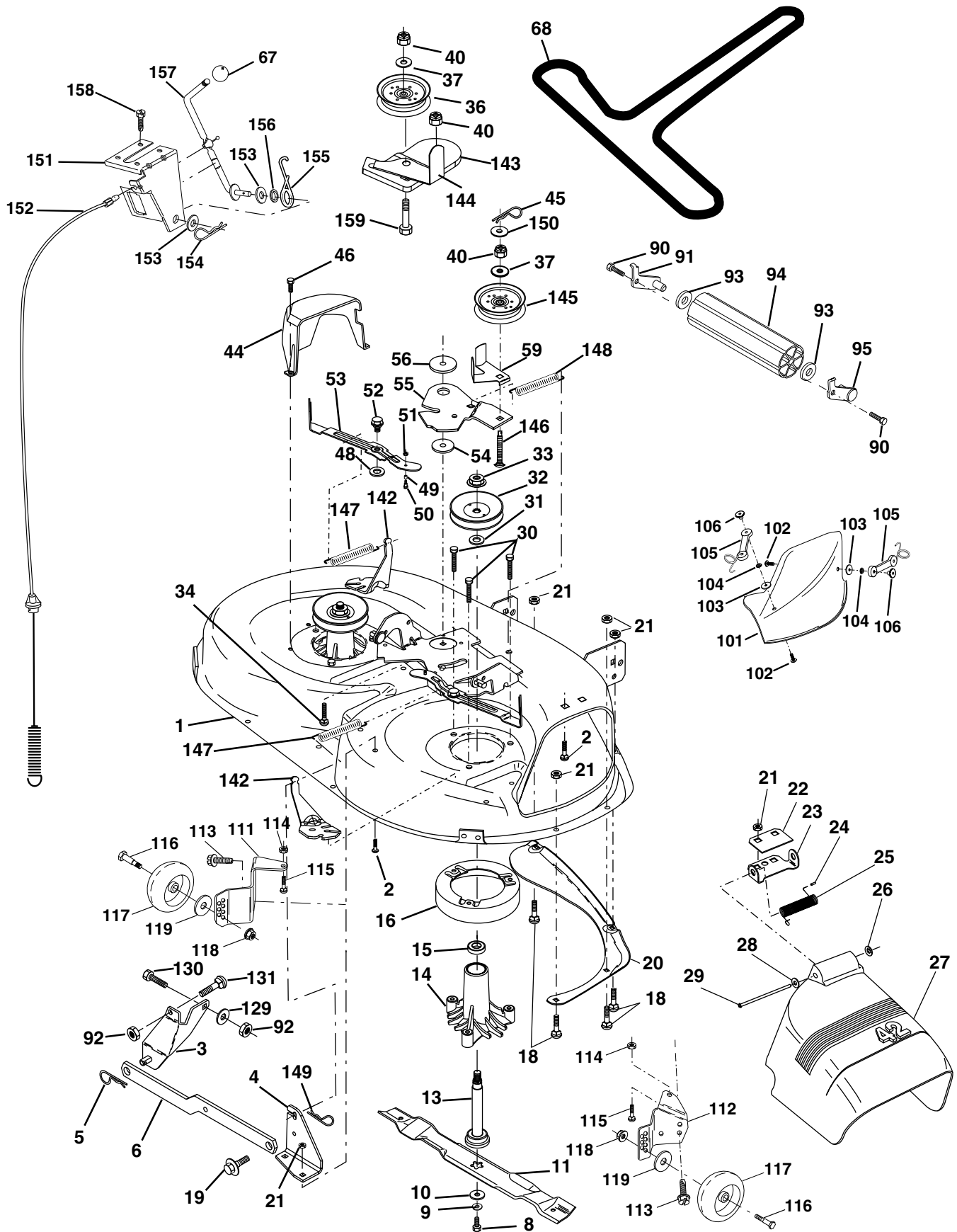

REPAIR PARTS

TRACTOR - - MODEL NUMBER 944.600952

MOWER DECK

KEY NO.	PART NO.	DESCRIPTION	KEY NO.	PART NO.	DESCRIPTION
1	165892	Mower Deck Assembly, 42"	59	141043	Guard TUV Idler
2	STD533107	Bolt	67	149846	Knob Custom Oval
3	138017	Bracket Asm Fr. Sway Bar 3/42	68	144959	V-Belt, 42" Mower
4	165460	Bracket Asm Deck 42" Sway Bar	90	17490612	Screw Thdrol 3/8-16 x 3/4
5	STD624008	Retainer Spring	91	175746	Bracket Asm Noseroller LH
6	130832	Arm, Suspension, Rear	92	STD541437	Nut, Lock, Hex W/Ins 3/8-16 UNC
8	850857	Bolt 3/8-24 x 25 Grade 8 patched	93	19171416	Washer 17/32 x 7/8 x 16 Ga.
9	STD551137	Washer, Lock	94	132264	Roller Nose 38 & 42
10	140296	Washer, Hardened	95	175747	Bracket Asm Noseroller RH
11	134149	Blade, Mulching 42" Std (Originally equipped with)	101	136420	Mulcher Cover
		(Following Blades are Optional)	102	71161010	Screw
	138498	Blade Mower 42" Hi-Lift Std (For better bagging, especially in wet conditions)	103	19061216	Washer, Flat
			104	10071000	Washer, Lock
	139775	Blade Mulching Premium 42" (For better wear when mulching)	105	160793	Latch Assembly
			106	2029J	Nut, Weld
	138971	Blade Mower 42" Hi-Lift Premium (For better wear when bagging in heavy or wet conditions)	111	155197	Bracket, Gauge, Wheel LH
13	137645	Shaft Assembly, Mandrel, Vented	112	155198	Bracket, Gauge, Wheel RH
14	128774	Housing, Mandrel, Vented	113	17060514	Screw 5/16 - 18
15	110485X	Bearing, Ball, Mandrel	114	STD541431	Nut, Keps 5/16 - 18 UNC
16	174493	Stripper, Mower Deck	115	72110504	Bolt, Carriage 5/16-18 x 1/2
18	STD533106	Bolt, Carriage 5/16-18 x 5/8	116	4898H	Bolt, Shoulder
19	132827	Bolt, Shoulder	117	165746	Wheel, Gauge
20	159770	Baffle, Vortex	118	73930600	Nut Centerlock 3/8-16
21	STD541431	Nut	119	19121414	Washer 3/8 x 7/8 x 14 Ga.
22	134753	Stiffener Bracket	121	143723	Bracket, Extruded
23	131267	Bracket, Deflector Mower 42"	129	19131312	Washer 13/32 x 13/16 x 12 Ga.
24	105304X	Cap, Sleeve 80 x 112 Blk Mower	130	STD523710	Bolt Fin Hex 3/8-16 UNC x 1 Gr. 5
25	123713X	Spring, Torsion, Deflector 2 52	131	STD533710	Bolt Rdhd Sqnk 3/8-16 UNC x 1
26	110452X	Nut, Push Phos & Oil	142	165890	Arm Spring Brake Mower
27	130968X428	Shield, Deflector 42" Blk	143	157109	Bracket Arm Idler 42"
28	19111016	Washer 11/32 x 5/8 x 16 Gauge	144	158634	Keeper Belt 42" Clutch Cable
29	131491	Rod, Hinge 42" 6 75 W/G	145	165888	Pulley Idler Flat
30	157722	Screw Thdrol Washer Head	146	171977	Bolt Carriage Idler
31	129963	Washer, Spacer Mower Vented	147	131335	Spring Extension
32	153535	Pulley, Mandrel	148	169022	Spring Return Idler
33	137266	Nut, Toplock 9/16	149	165898	Retainer Spring Yellow
34	STD533717	Bolt	150	19091216	Washer 9/32 x 3/4 x 16 Ga.
36	131494	Pulley, Idler, Flat	151	169670	Bracket Clutch Cable
37	STD551037	Washer 13/32 x 13/16 x 16 Gauge	152	169676	Clutch Cable 42"
40	STD541437	Nut	153	169674	Washer Flat 3/8" Type B
44	140088	Guard, Mandrel, LH	154	169675	Spring Retainer
45	STD624003	Retainer	155	169671	Spring Retention LVR CLTCH CAB
46	137729	Screw, Thdrol 1/4-20 x 5/8 T	156	169672	Spacer Clutch Cable
48	133944	Washer, Hardened	157	169669	Rod Clutch Cable 3/8"
49	174284	Roller Assembly, Cam Follower	158	17720410	Screw Hex Thd Cut 1/4-20 x 5/8
50	131340	Bolt, Shoulder #10-24 Grade 5	159	72140614	Bolt Rdhd Sqnk 3/8-16 UNC x 1-3/4
51	STD541410	Locknut	--	130794	Mandrel Assembly (Includes Key Numbers 8-10, 13-15, 31 and 33)
52	139888	Bolt, Shoulder 5/16-18 UNC	--	169583	Replacement Mower, Complete
53	131845	Arm Assembly, Pad, Brake			
54	133943	Washer, Hardened			
55	155046	Arm, Idler			
56	165723	Spacer, Retainer			

NOTE: All component dimensions given in U.S. inches
1 inch = 25.4 mm

REPAIR PARTS

TRACTOR - - MODEL NUMBER 944.600952

MOWER LIFT

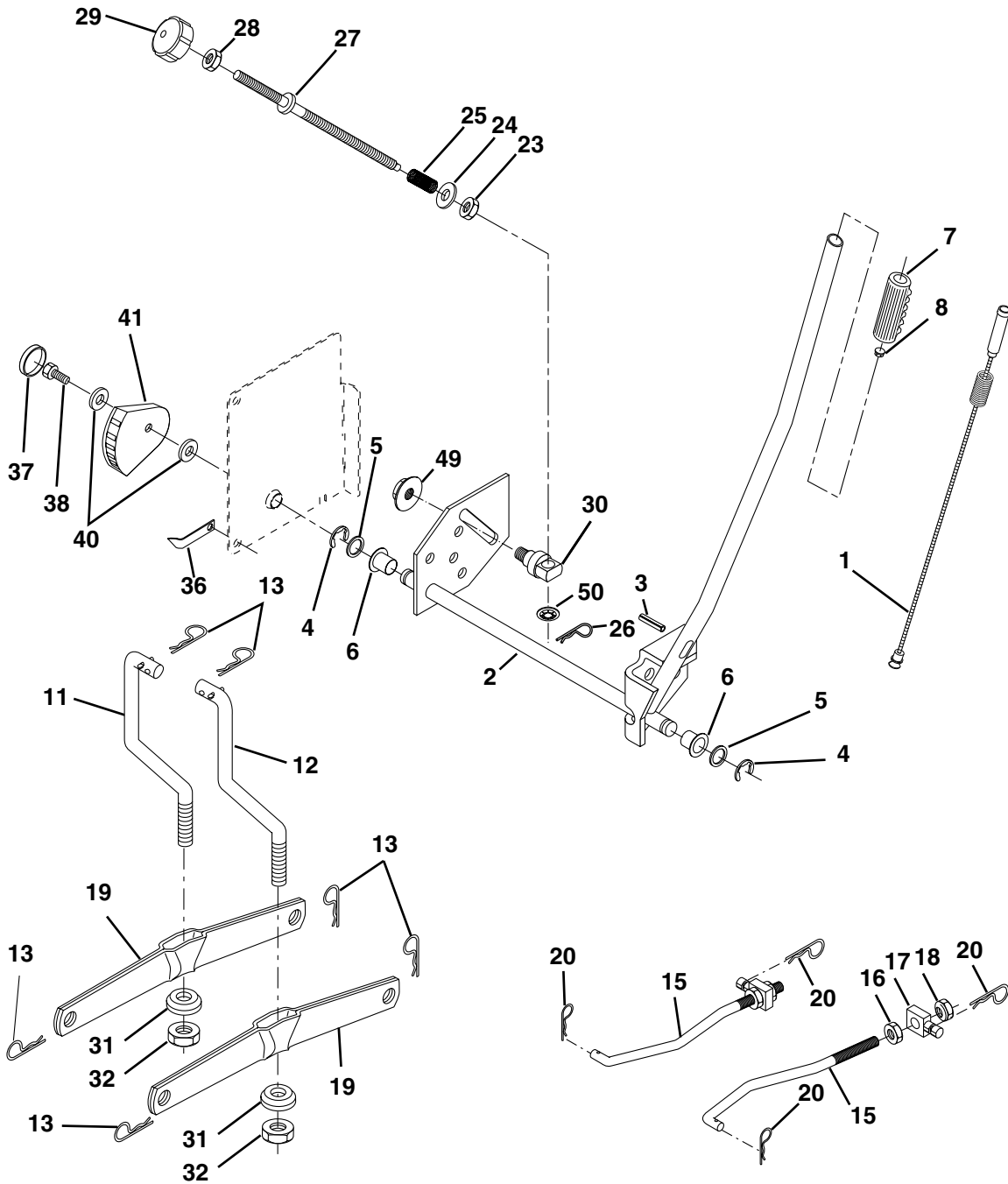

REPAIR PARTS

TRACTOR - - MODEL NUMBER 944.600952

MOWER LIFT

KEY NO.	PART NO.	DESCRIPTION
1	159460	Wire Asm Inner/Sprg W/plunger LT
2	159471	Shaft Asm Lift RH w/Inf
3	105767X	Pin Groove 1 500 Zinc
4	STD581062	E Ring #5133-62
5	19211621	Washer 21/32 X 1 X 21 Ga
6	120183X	Bearing Nylon Blk 629 Id
7	125631X	Grip Handle
8	122365X	Button Plunger
11	139865	Link Lift LH Fixed Length
12	139866	Link Lift RH Fixed Length
13	STD624008	Retainer Spring
15	173288	Link Front
16	73350800	Nut Jam Hex 1/2-13 Unc
17	130171	Trunnion Blk Zinc
18	STD541450	Nut Lock W/Wsh 1/2-13 Unc
19	139868	Arm Suspension Rear
20	163552	Retainer Spring
23	110807X	Nut Special
24	STD551037	Washer 13/32 X 5/8 X 16 Ga
25	2876H	Spring 2-1/8"
26	169484	Retainer Clip
27	126971X	Rod Adj Lift Zinc 7.49 Wrk Lg
28	STD541237	Nut Hex Jam 3/8-16 Unc
29	138057	Knob Inf 3/8-16 Unc Blk W/sym
30	150233	Trunnion Infin Height
31	169865	Bearing Pvt Lift
32	73540600	Nut Crownlock 3/8 - 24
36	155097	Pointer Hght Ind
37	123935X	Plug Hole Blk
38	17060516	Screw 5/16-18 x 1.0
40	19112410	Washer 11/32 x 1-1/2 x 10 Ga
41	155098	Indicator Hght.
49	145212	Nut Hex Flange Lock
50	110452X	Nut Push Phos & Oi

NOTE: All component dimensions given in U.S. inches
1 inch = 25.4 mm

REPAIR PARTS

TRACTOR - - MODEL NUMBER 944.600952

HYDRO GEAR TRANSAXLE - MODEL NUMBER 314-0510

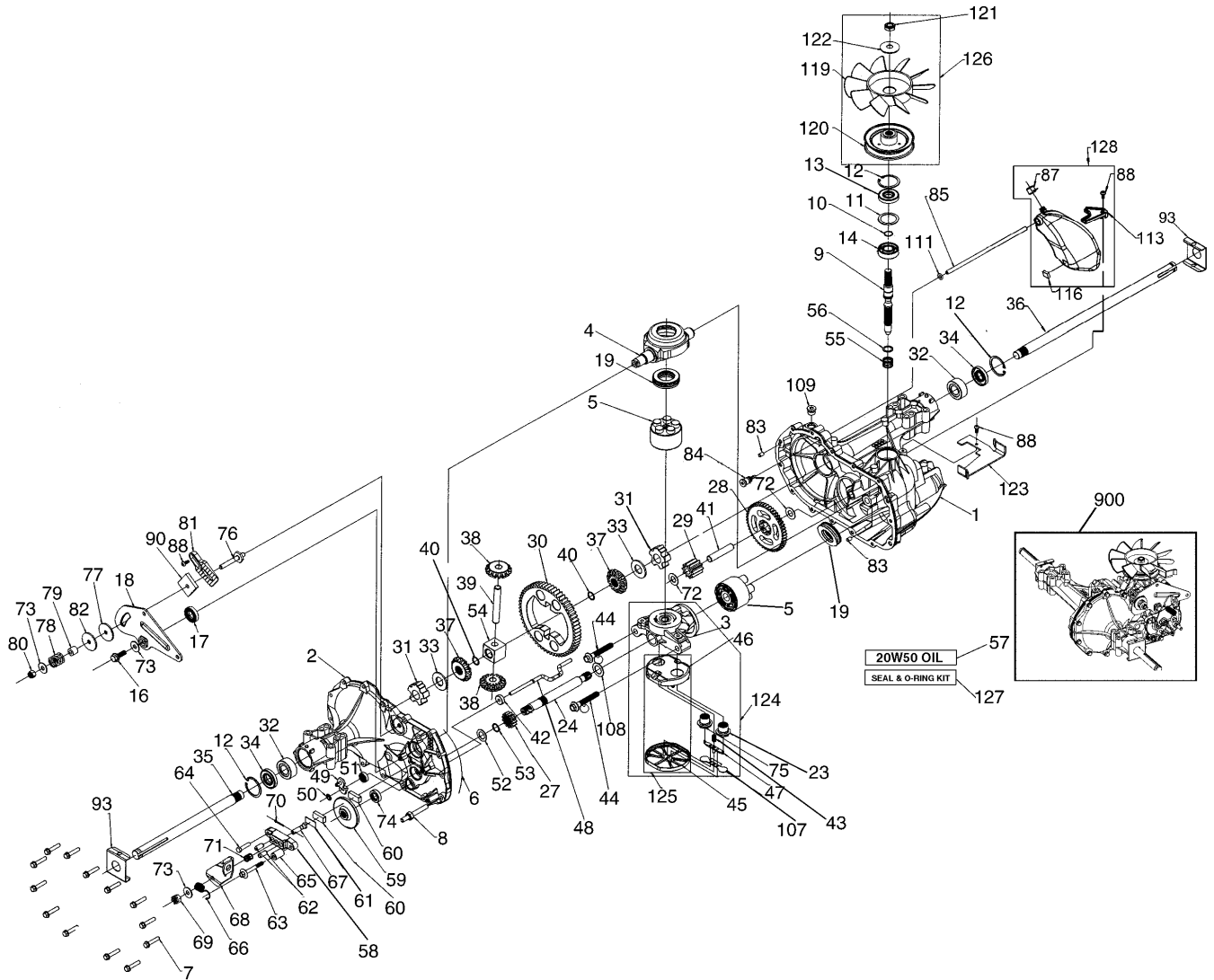

REPAIR PARTS

TRACTOR - - MODEL NUMBER 944.600952

HYDRO GEAR TRANSAXLE - MODEL NUMBER 314-0510

KEY NO.	PART NO.	DESCRIPTION	KEY NO.	PART NO.	DESCRIPTION
1	170351	Main Housing, Assembly	59	170408	Rotor, Brake
2	170352	Side Housing, Assembly	60	142883	Brake Puck
3	170353	Center Section, Assembly	61	142882	Puck Plate
4	170354	Swashplate, Trunion Machined	62	142887	Brake Actuating Pin
5	169898	Block - Assembly	63	170410	Hfhcs 1/4-20x2 W/ Patch,SpecialFlange
6	170355	Sealant 10.5 Oz			
7	170356	Hex Flange Screw 1/4-20 X 1.25	64	142892	Bolt, 1/4-20 X 1 W/Patch
8	170357	Stud, 5/16-24 Hex Double End	65	170411	Spacer
9	170358	Shaft, Input	66	170412	Spring, Brake Arm Bias
10	170359	Ring - Retaining	67	170413	Sq. Hd. Bolt 5/16-24-Ribbed
11	170360	Spacer	68	170414	Arm, Brake
12	169870	Ring - Retaining	69	170415	Slotted Hex Nut 5/16-24
13	170361	Seal, Lip .67 X 1.58 X .276	70	170416	Cotter Pin 3/32 X 3/4
14	169869	Ball Brg 17mm Id X 40mm Od X 12mm	71	170417	Compression Spring Brake Anti-Drag
16	170362	Hex Flange Head Screw 5/16- 24X0.75	72	170418	Washer, Ht .5 I.D. X 1 O.D. X .032
17	170363	Lip Seal 18 X 32 X 7	73	142884	Flat - Washer 11/32 I.D. X 7/8 O.D
18	170364	Arm, Control	74	170419	Oil Seal .625 X 1.0 X .25
19	150771	Bearing, 30x52x13 Thrust	75	170420	Check Plug Assembly, .027, Washer
23	170365	Check Plug Assembly, Washer	76	170421	Stud, 5/16-24 Friction Pack
24	170366	Shaft, Motor	77	170422	Puck, .330 X 1.50 X .0975
27	170367	Gear - Pinion, 13t	78	142969	Spring, Helical Comp
28	170368	10t/48t Gear	79	142980	Spacer
29	170369	Gear, 10t Jackshaft	80	150778	Hex Lock Nut 5/16-24Unjf(Nylon Insert)
30	170370	60t Bull Gear	81	170423	Wedge, Friction Pack
31	170371	Sleeve Bearing .75 X 1.575 X .625	82	170424	Clip, Washer .316x1.50x.1046 (Plated)
32	170389	SleeveBearing(Outboard) .75x1.750x.625	83	161168	Pin, Standard Headless
33	142991	Washer, 3/4 Id X 1-1/2 Od X .13 Thk	84	170425	Fitting, 5/16 Sae 5/32 Tube
34	170390	Lip Seal Axle Seal	85	170426	Hose, Expansion Tank
35	170391	Shaft, Axle .75 X 11.39 (Key, R.H.)	87	142917	Cap - Poppet Valve
36	170392	Shaft, Axle .75 X 16.99 (Key, L.H.)	88	170429	Bolt, Self Tapping 10-32 X 1/2
37	150792	Miter Gear (Splined)	90	170430	Puck, Inner Wedge
38	150793	Miter Gear 15t (0.5 Id)	93	170431	Spring Clip - Housing Thrust
39	150809	Shaft	107	170432	Deflector
40	170393	Ring, Spiral Retaining	108	170433	Washer, Motor Shaft .71idx1.15odx.030thk
41	170394	Pin, Jackshaft	109	170434	Plug, Sae #6
42	170395	Magnet, Ring	111	170435	O-Ring .07 X .301 I.D.
43	170396	Spring, Bypass	113	170437	Bracket, Support Expansion Tank
44	150797	Hydro Mtg Screw 3/8-24 X 2.5 Long	116	170438	Silicon Sponge
45	170397	Filter	119	170439	Fan, 7 In.
46	170398	Base, Filter	120	170440	Pulley
47	170399	Actuator, Bypass	121	170441	Hex Lock Nut 1/2-20 (Nylon Insert)
48	170400	Rod, Bypass Actuator	122	170442	Washer, Belleville
49	170401	Arm, Bypass	123	170443	Belt Keeper
50	170402	Retaining Ring .250 External	124	170444	Center Section-Filter-Bypass Assembly
51	170403	Seal, Lip .741 X .250 X .250 Tc	125	170445	Filter Assembly
52	170404	Flat Washer, 5/8 Id X 1.0 Od X .05 Thk	126	170446	Fan - Pulley Service Assembly
53	170405	Retaining Ring	127	170447	Seal - O-Ring Kit
54	170406	Bearing, Center Block	128	173165	Kit, Expansion Tank
55	142977	Spring - Helical Compression	900	166768	Transaxle Complete
56	142978	Washer			
57	150798	20w-50 Oil			
58	170407	Brake Yoke			

NOTE: All component dimensions given in U.S. inches
1 inch = 25.4 mm

REPAIR PARTS

TRACTOR - - MODEL NUMBER 944.600952

KOHLER ENGINE - MODEL NUMBER CV490, TYPE NUMBER 27508

CYLINDER HEAD, VALVE AND BREATHER

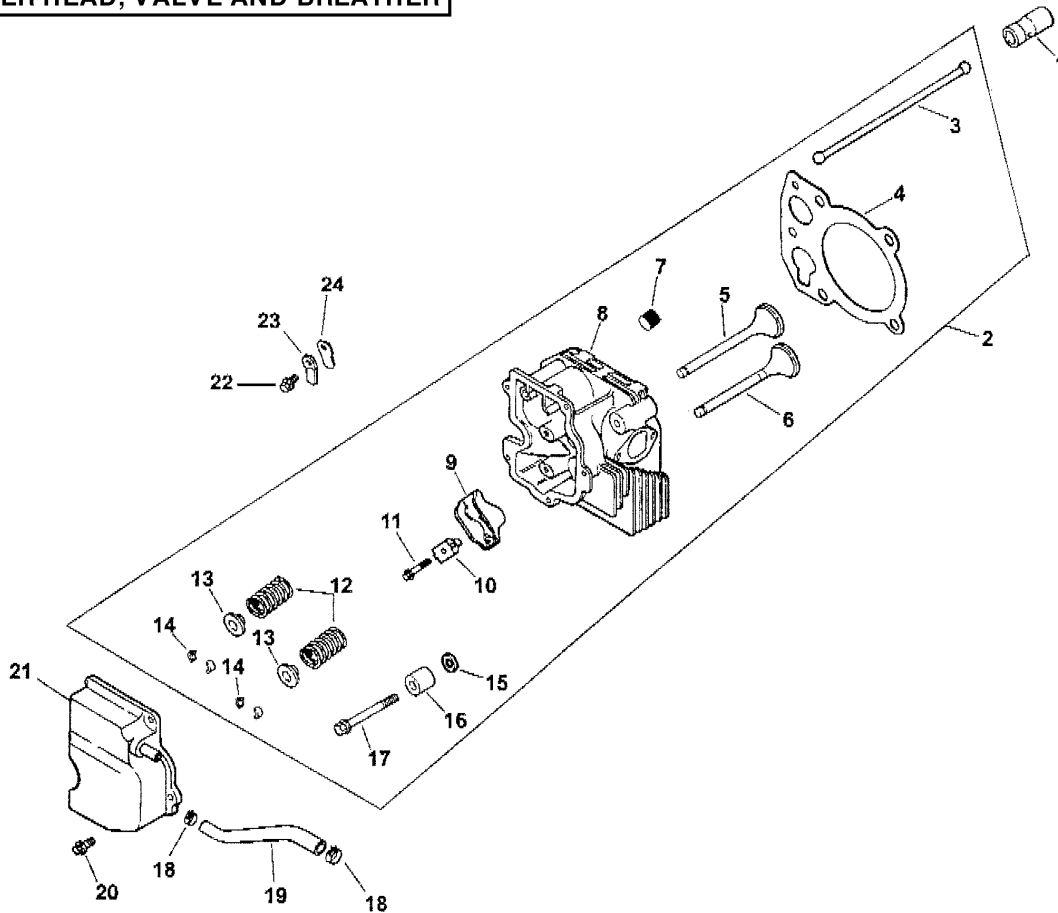

CRANKCASE

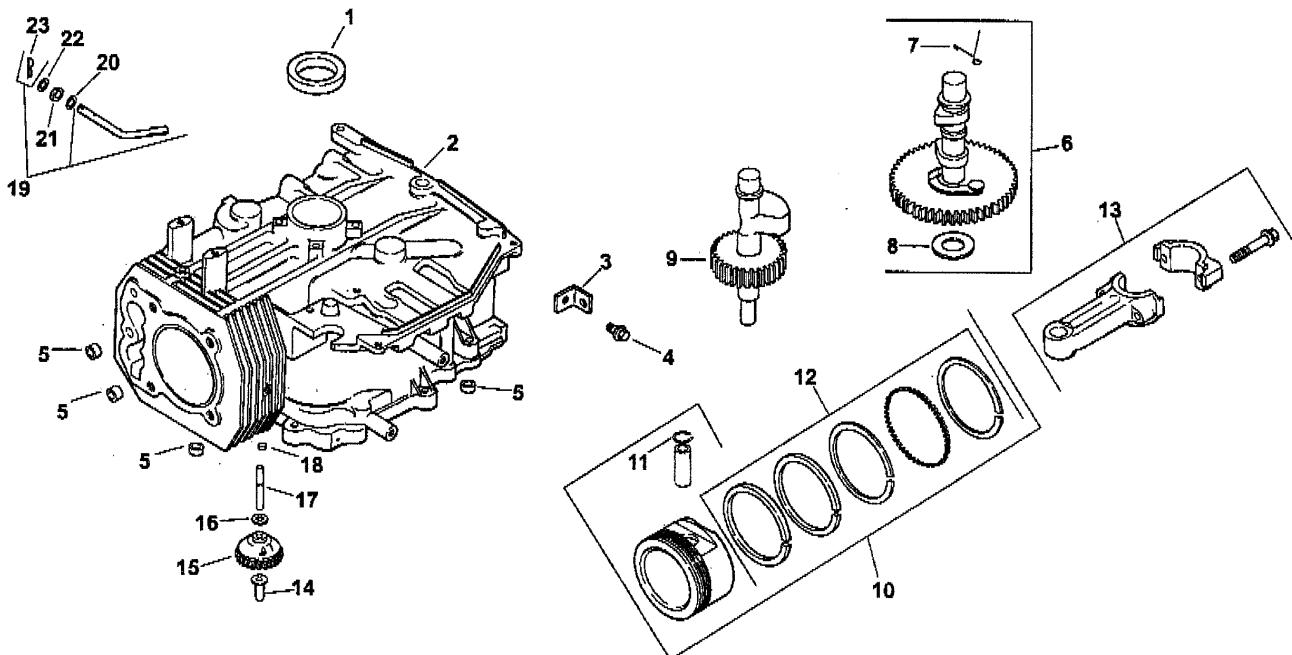

REPAIR PARTS

TRACTOR - - MODEL NUMBER 944.600952

KOHLER ENGINE - MODEL NUMBER CV490, TYPE NUMBER 27508

CYLINDER HEAD/VALVE/BREATHER

KEY NO.	PART NO.	DESCRIPTION
1	25-351-01-S	Lifter, valve (2)
2	12-755-94-S	Kit, cylinder head (Includes 3-17, Gaskets 12 041 01-S (Qty. 2), 12 041 02-S, & 12 041 03-S)
3	12-411-03-S	Rod, push (2)
4	12-041-10-S	Gasket, cylinder head
5	12-017-01-S	Valve, intake (Std.)
	12-017-02-S	Valve, intake (.25)
6	12-016-01-S	Valve, exhaust (Std.)
	12-016-02-S	Valve, exhaust (.25)
7	25-139-60-S	Plug, allen hd. pipe 1/8"
8	12-318-36-S	Cylinder Head
9	25-186-01-S	Arm, rocker (2)
10	12-599-03-S	Pivot, rocker arm (2)
11	M-640034-S	Screw, hex. flange M6x1.0x34 (2)
12	12-089-01-S	Spring, valve (2)
13	12-173-01-S	Cap, valve spring (2)
14	12-755-03-S	Kit, retainer (2)
15	12-468-05-S	Washer, plain 13/32"
16	12-112-13-S	Spacer, head bolt exhaust port
17	12-086-15-S	Screw, hex. flange M10x1.5x81 (5)
18	25-237-14-S	Clamp, hose (2)
19	12-326-03-S	Hose, breather
20	M-645020-S	Screw, hex. flange M6x1.0x20 (5)
21	12-096-07-S	Cover, valve w/nipple
22	M-545010-S	Screw, hex. flange M5x0.8x10
23	12-018-01-S	Retainer, breather reed
24	12-402-02-S	Reed, breather

CRANKCASE

KEY NO.	PART NO.	DESCRIPTION
1	12-032-03-S	Seal, crankshaft
2		Block, cylinder (Use Short Block 12 522 51)
3	12-445-02-S	Strap, lifting
4	M-839025-S	Screw, hex. flange M8x1.25x25
5	24-380-13-S	Dowel, locating (4)
6	12-755-49-S	Kit, camshaft (Includes 7,8)
7	12-089-31-S	Spring, actuating
8	12-422-08-S	Shim, camshaft (A.R.) blue
	12-422-09-S	Shim, camshaft (A.R.) red
	12-422-10-S	Shim, camshaft (A.R.) yellow
	12-422-11-S	Shim, camshaft (A.R.) green
	12-422-12-S	Shim, camshaft (A.R.) gray
	12-422-13-S	Shim, camshaft (A.R.) black
	12-422-07-S	Shim, camshaft (A.R.) white
9	12-144-28-S	Shaft, balance
10	12-874-07-S	Piston w/Ring Set (Std.) (Includes 11,12)
	12-874-11-S	Piston w/Ring Set (.08)
	12-874-08-S	Piston w/Ring Set (.25)
	12-874-09-S	Piston w/Ring Set (.50)
11	12 018 02-S	Retainer, piston pin (2)
12	12-108-07-S	Ring Set (Std.)
	12-108-08-S	Ring Set (.25)
	12-108-09-S	Ring Set (.50)
13	12-067-11-S	Connecting Rod (Std.)
	12-067-06-S	Connecting Rod (.25)
14	12-380-01-S	Pin, governor regulating
15	12-043-05-S	Gear, governor
16	M-631005-S	Washer, plain 6 mm
17	12-144-02-S	Shaft, governor gear
18	52-139-09-S	Plug, cup
19	12-755-64-S	Kit, gov. cross shaft w/clip (Includes 23)
20	X-25-102-S	Washer, plain 1/4"
21	12-032-01-S	Seal, governor cross shaft
22	M-631015-S	Washer, plain 6 mm
23	12-154-05-S	Clip, hitch pin

NOTE: All component dimensions given in U.S. inches
1 inch = 25.4 mm

REPAIR PARTS

TRACTOR - - MODEL NUMBER 944.600952

KOHLER ENGINE - MODEL NUMBER CV490, TYPE NUMBER 27508

IGNITION/ELECTRICAL

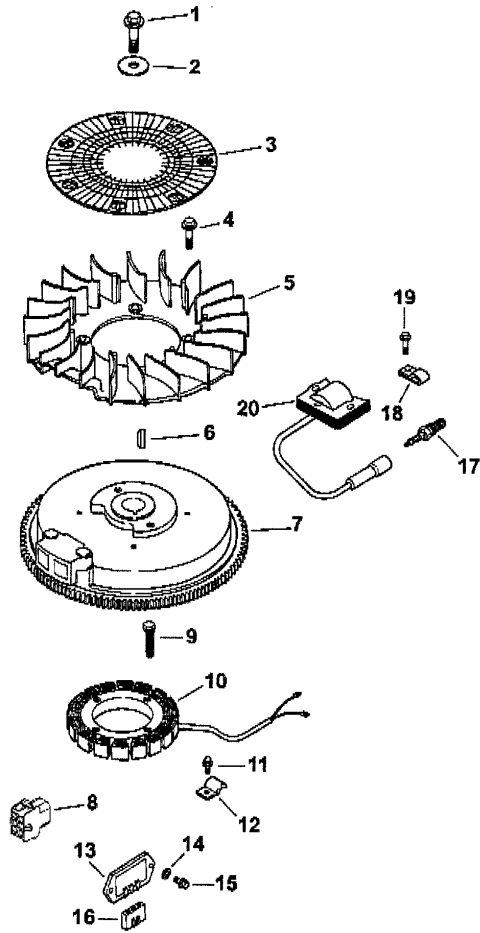

BLOWER HOUSING AND BAFFLES

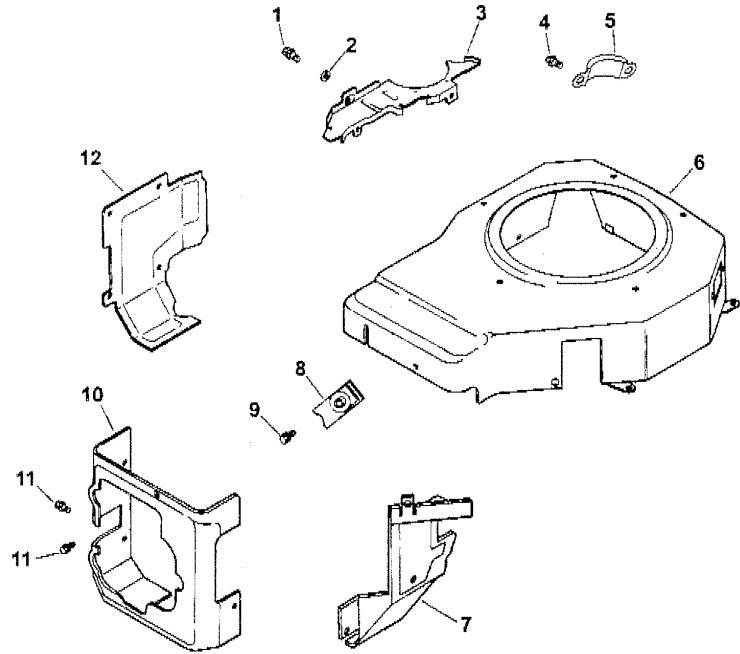

AIR INTAKE

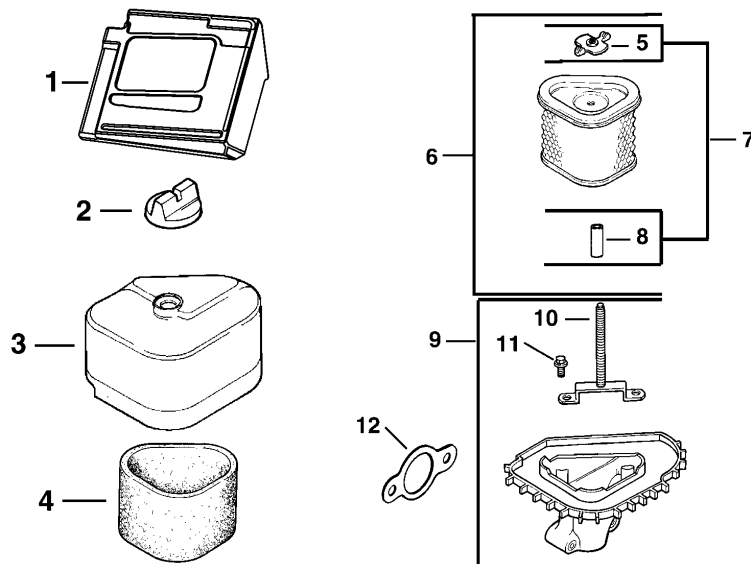

REPAIR PARTS

TRACTOR - - MODEL NUMBER 944.600952

KOHLER ENGINE - MODEL NUMBER CV490, TYPE NUMBER 27508

IGNITION/ELECTRICAL

KEY NO.	PART NO.	DESCRIPTION
1	12-086-14-S	Screw, hex. flange M10x1.5x46
2	12-468-03-S	Washer, plain 3/8"
3	24-162-03-S	Screen, grass
4	25-086-47-S	Bolt, shoulder M6x1.0x16 (4)
5	12-157-06-S	Fan
6	X-42-15-S	Key
7	12-025-15-S	Flywheel
8	12-155-09-S	Connector
9	M-548025-S	Screw, hex. cap M5x0.8x25 (2)
10	12-085-09-S	Stator - 15 amp with stator brake
11	M-545020-S	Screw, hex. flange M5x0.8x20 (2)
12	12-154-06-S	Clip, cable (2)
13	41-403-09-S	Regulator, rectifier - 15 amp
14	X-22-11-S	Washer, lock 1/4"
15	M-639016-S	Screw, hex. flange M6x1.0x16 (2)
16	236602-S	Connector
17	12-132-02-S	Spark Plug
18	X-728-1-S	Clip, cable (2)
19	M-545010-S	Screw, hex. flange M5x0.8x10 (2)
20	12-584-04-S	Module, ignition
NOT ILLUSTRATED		
	12-176-44-S	Harness, wiring
	24-518-12-S	Lead, black (6" - 12 gauge- insulated grip barrel eyelet terminals)
	12-518-35-S	Lead, white (36" - 18 gauge - fully insulated push on tab and unisulated socket terminals)

BLOWER HOUSING & BAFFLES

KEY NO.	PART NO.	DESCRIPTION
1	M-545010-S	Screw, hex. flange M5x0.8x10 (6)
2	24-468-10-S	Washer, plain 1/4"
3	12-146-07-S	Plate, blower housing
4	M-550010-S	Screw, hex. flange M5x0.8x10
5	24-096-05-S	Cover, pinion
6	12-027-76-S	Housing, blower
7	12-063-18-S	Baffle, intake side
8	25-154-02-S	Clip, mounting (3)
9	12-086-37-S	Screw, captive washer M5x0.8x20 (3)
10	12-063-20-S	Baffle, cylinder head
11	M-645016-S	Screw, hex. flange M6x1.0x16 (2)
12	12-063-19-S	Baffle, cylinder
NOT ILLUSTRATED		
	M-541050-S	Nut, hex. flange M5x0.8

AIR INTAKE/FILTRATION

KEY NO.	PART NO.	DESCRIPTION
1	12-281-01-S	Duct, air
2	25-341-03-S	Knob, air cleaner cover
3	12-096-24-S	Cover, air cleaner
4	12-083-12-S	Precleaner, element
5	12-100-08-S	Wing Nut
6	12-083-10-S	Kit, air cleaner element (Includes 5, 7, 8)
7	12-743-12-S	Filter, element (Includes 5, 8)
8	12-032-11-S	Seal 1-7/16"
9	12-094-07-S	Base, air cleaner (Includes 11, 12)
10	12-072-04-S	Stud, mounting plate M6x1.0x75
11	12-086-01-S	Screw, #10 Hi-Lo thread forming (2)
13	12-041-02-S	Gasket, air cleaner
NOT ILLUSTRATED		
	12-113-53-S	Decal, air cleaner

NOTE: All component dimensions given in U.S. inches
1 inch = 25.4 mm

REPAIR PARTS

TRACTOR - - MODEL NUMBER 944.600952

KOHLER ENGINE - MODEL NUMBER CV490, TYPE NUMBER 27508

STARTING SYSTEM

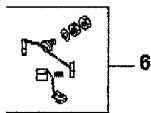
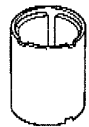
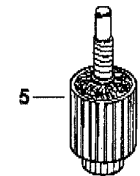
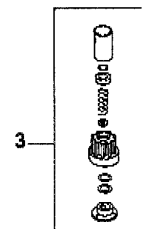
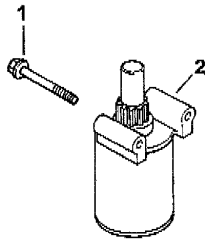

ENGINE CONTROLS

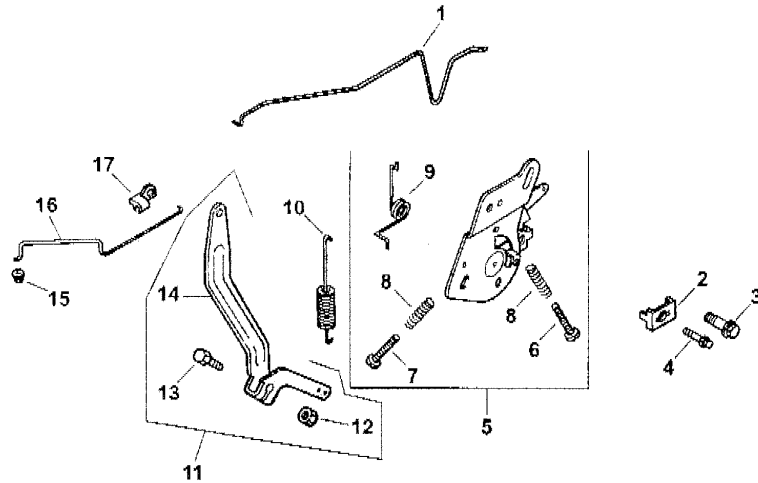

OIL PAN / LUBRICATION

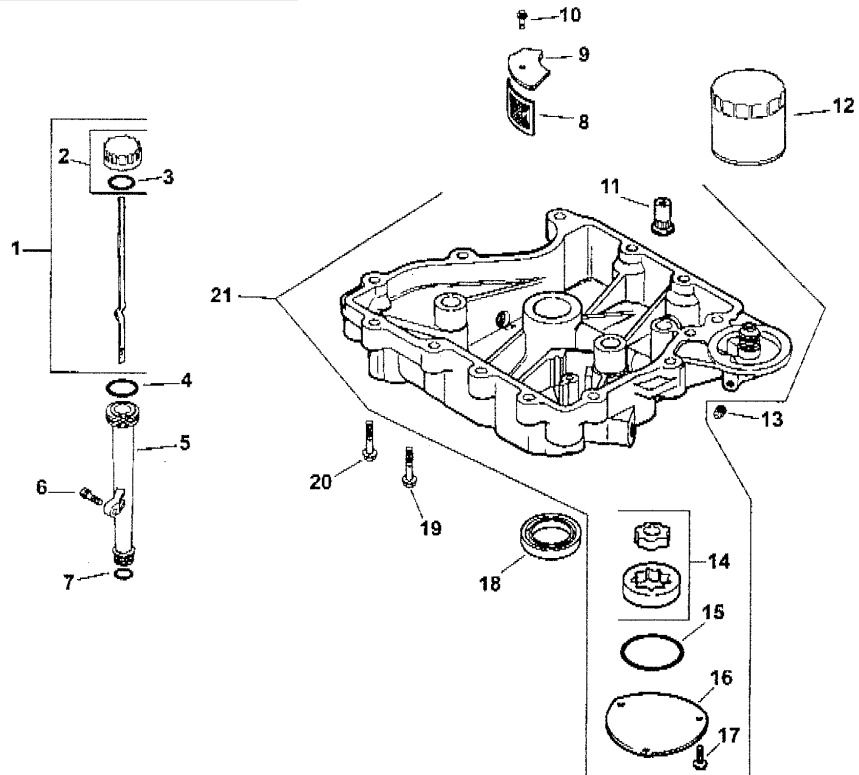

REPAIR PARTS

TRACTOR - - MODEL NUMBER 944.600952

KOHLER ENGINE - MODEL NUMBER CV490, TYPE NUMBER 27508

STARTING SYSTEM

KEY NO.	PART NO.	DESCRIPTION
1	M-839070-S	Screw, hex. flange M8x1.25x70 (2)
2	25-098-07-S	Starter assembly (Includes 3-8)
3	12-755-54-S	Kit, drive end
4	12-227-18-S	Cap, drive end
5	12-170-05-S	Armature
6	12-221-01-S	Kit, brush & spring
7	12-227-13-S	Cap, commutator end
8	12-211-01-S	Bolt, hex. flange 1/4-20x4-5/8 (2)

OIL PAN/LUBRICATION

KEY NO.	PART NO.	DESCRIPTION
1	12-038-01-S	Dipstick assembly (Includes 2-3)
2	25-755-13-S	Kit, oil fill cap (Includes 3)
3	12-153-03-S	O-Ring, oil fill cap
4	12-153-02-S	O-Ring, upper oil fill tube
5	12-123-04-S	Tube, oil fill
6	M-645025-S	Screw, hex. flange M6x1.0x25
7	12-153-01-S	O-Ring, lower oil fill tube
8	25-162-07-S	Screen, oil pickup
9	12-096-03-S	Cover, oil pickup screen
10	M-545016-S	Screw, hex. flange M5x0.8x16
11	25-462-09-S	Valve, oil pressure relief
12	52-050-02-S	Filter, oil
13	25-139-57-S	Plug, sq. hd. solid 3/8"
14	12-393-01-S	Pump, oil
15	12-153-06-S	O-Ring, oil pump cover
16	12-096-34-S	Cover, oil pump
17	M-545016-S	Screw, hex. flange M5x0.8x16 (3)
18	12-032-03-S	Seal, oil (P.T.O. end)
19	24-086-16-S	Screw, hex. flange M8x1.25x45 (11)
20	24-086-17-S	Screw, hex. flange M8x1.25x45
21	12-199-56-S	Assembly, Pan, oil (Incl. 11,14-17)

ENGINE CONTROLS

KEY NO.	PART NO.	DESCRIPTION
1	12-079-11-S	Linkage, choke
2	12-237-01-S	Clamp, cable
3	24-086-43-S	Screw, hex. flange
4	M-664020-S	Screw, lobed socket M6x1.0x20 (2)
5	12-536-10-S	Control, speed assembly (Includes 6-9)
6	M-443025-S	Screw, pan head M4x0.7x25
7	M-443020-S	Screw, pan head M4x0.7x20
8	12-089-11-S	Spring, choke (2)
9	12-089-23-S	Spring, choke return
10	12-089-24-S	Spring, governor
11	12-755-83-S	Kit, governor lever (Includes 12-14)
12	12-100-07-S	Nut, hex flange 1/4-20
13	52-211-04-S	Bolt, 1/4-20x1"
14	12-090-28-S	Lever, governor
15	25-158-08-S	Bushing, throttle linkage
16	12-079-10-S	Linkage, throttle
17	25-158-11-S	Bushing, throttle linkage

NOTE: All component dimensions given in U.S. inches
1 inch = 25.4 mm

REPAIR PARTS

TRACTOR - - MODEL NUMBER 944.600952

KOHLER ENGINE - MODEL NUMBER CV490, TYPE NUMBER 27508

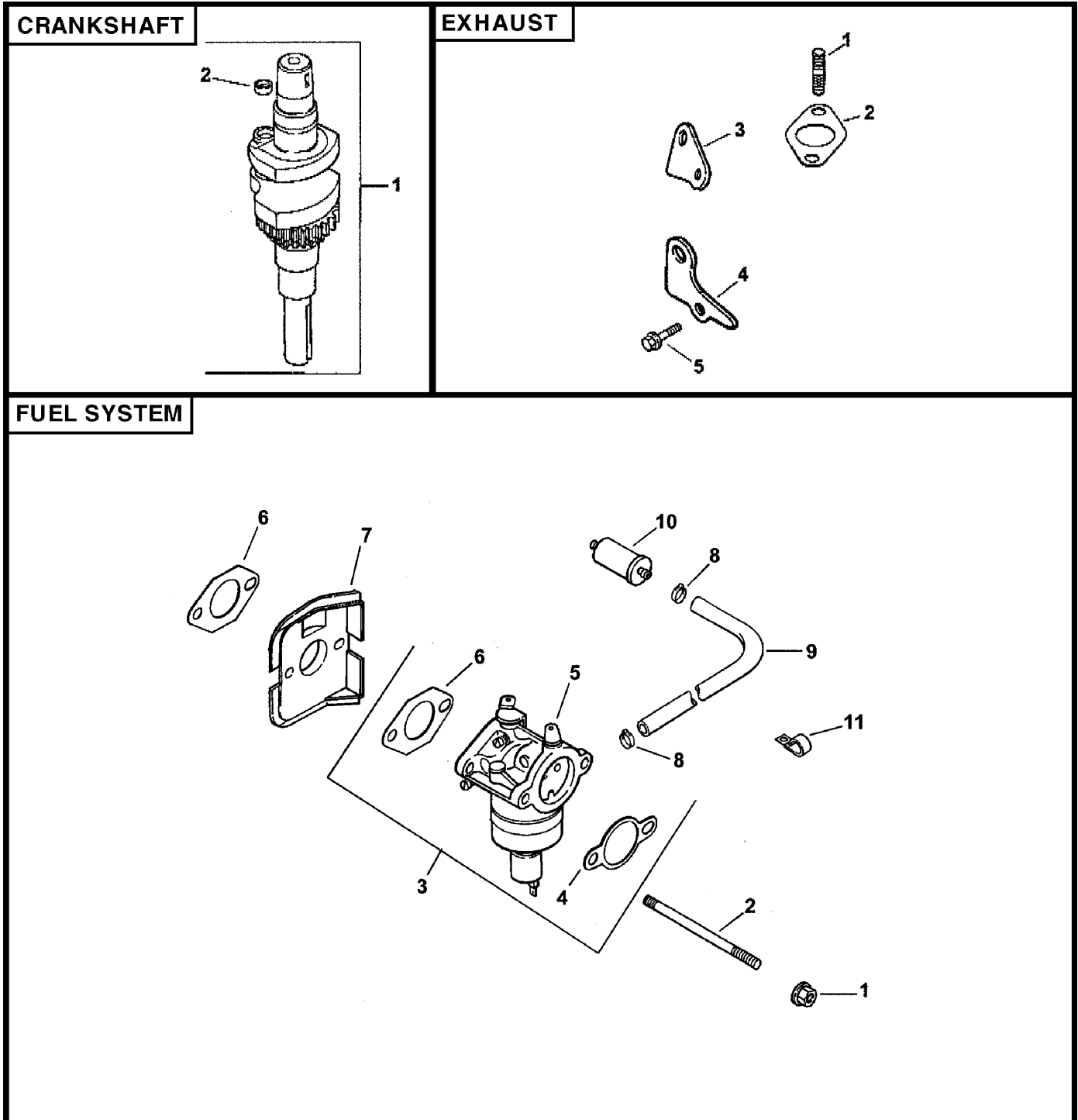

REPAIR PARTS

TRACTOR - - MODEL NUMBER 944.600952

KOHLER ENGINE - MODEL NUMBER CV490, TYPE NUMBER 27508

FUEL SYSTEM

KEY NO.	PART NO.	DESCRIPTION
1	M-641060-S	Nut, hex. flange M6x1.0 (2)
2	M-629116-S	Stud M6x1.0x116 (2)
3	12-853-118-S	Kit, carburetor w/gasket (Includes 4,5,6 qty 1 Tie, cable 12-454-03-S, Terminal 25-452-20-S)
4	12-041-02-S	Gasket, air cleaner
5	12-053-118	Carburetor assembly (For information only not available separately) (Includes Kit, float 12-757-02-S Kit, carburetor repair 12-757-03-S, Kit, solenoid repair 12-757-33-S)
6	12-041-01-S	Gasket, carburetor (2)
7	12-265-06-S	Deflector, heat
8	25-237-14-S	Clamp, hose (2)
9	52-353-22-S	Line, fuel 12-1/4"
10	25-050-03-S	Filter, fuel in-line
11	47-154-01-S	Clip cable

NOT ILLUSTRATED

- *M-561010-S Screw, thread forming M5x0.8x10
- *X-22-11-S Washer, lock 1/4"
- 12-757-02-S Kit, float
- 12-757-03-S Kit, carburetor repair
- 12-041-01-S Gasket, carburetor
- 12-041-02-S Gasket, air cleaner
- 12-041-05-S Gasket, bowl
- 12-041-06-S Gasket, bowl screw
- 12-032-06-S Seal, solenoid
- 12-757-33-S Kit, solenoid repair
- 12-041-06-S Gasket, bowl screw
- 12-454-03-S Tie cable
- 25-452-20-S Terminal
- 12-518-37-S Lead, red, (37" - 20 gauge -
insulated socket and uninsulated
socket terminals)

*attaches carburetor ground lead to carb baffle.

CRANKSHAFT

KEY NO.	PART NO.	DESCRIPTION
1	12-014-57-S	Crankshaft (Includes 2)
2	25-139-27-S	Plug, cup

EXHAUST

KEY NO.	PART NO.	DESCRIPTION
1	25-072-04-S	Stud, M8x1.25x33(2)
2	12-041-03-S	Gasket, exhaust manifold
3	12-126-11-S	Bracket muffler
4	12-445-06-S	Strap, lifting
5	M-645025-S	Screw, hex. flange M6x1.0x25 (2)
	PA-27508	Replacement Engine
	12-522-51	Short Block
	12-755-93-S	Gasket Set

NOTE: All component dimensions given in U.S. inches
1 inch = 25.4 mm

SERVICE NOTES

SUGGESTED GUIDE FOR SIGHTING SLOPES FOR SAFE OPERATION

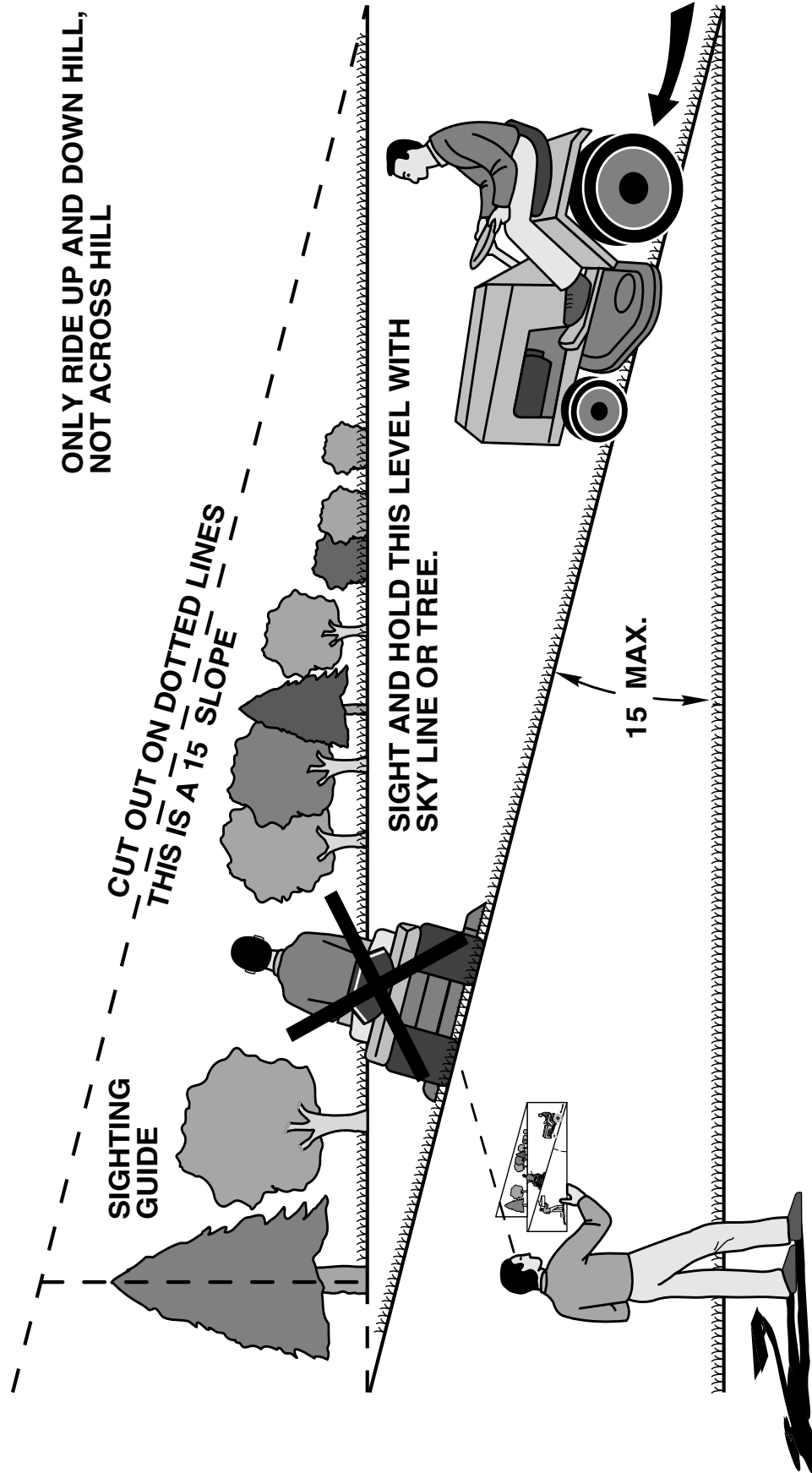

 Operate your Tractor up and down the face of slopes (not greater than 15°), never across the face. Make turns gradually to prevent tipping or loss of control. Exercise extreme caution when changing direction on slopes.

Get it fixed, at your home or ours!

Just Call:

1-800-4-MY-HOME[®]

(1-800-469-4663)

24 hours a day, 7 days a week

For the repair of major brand appliances **in your own home...**
no matter who made it, no matter who sold it!

For your nearest **Sears Parts and Service** location,
to bring in products like vacuums, lawn equipment and electronics.

For **Sears Parts & Service**, to order the replacement parts,
accessories and owner's manuals that you need to do-it-yourself.

www.sears.ca

To purchase or inquire about a Sears Maintenance Agreement, call:

1-800-361-6665

9 a.m. – 8 p.m. EST, Mon. – Fri., 4 p.m. Sat.

Pour service en français:

1-800-LE-FOYER^{MC}

(1-800-533-6937)

www.sears.ca



® / TM Trademarks of Sears, Roebuck and Co. used under license by Sears Canada

MC / MD Marque de commerce / déposée de Sears, Roebuck and Co. utilisée en vertu d'une licence de Sears Canada

© Sears