

Revision 7 English and 6 French
Updated art and parts list for transaxle.

SEARS
OWNER'S
MANUAL

**MODEL NO.
944.603900**

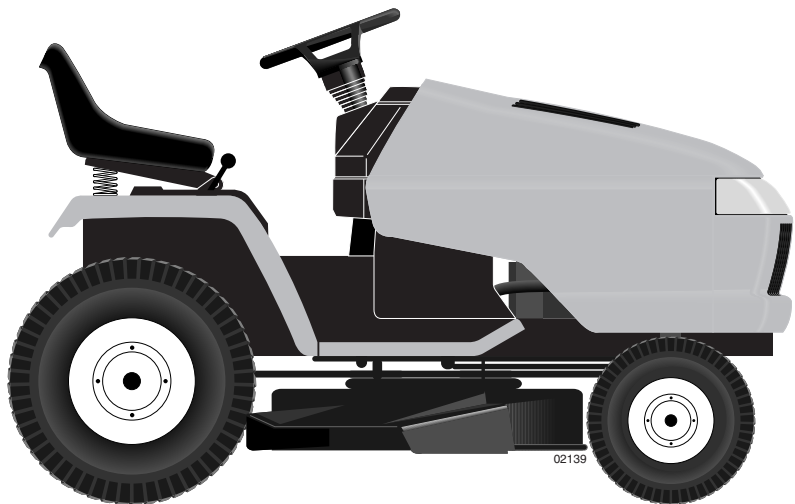

CRAFTSMAN®

00007

**Important:
Read and follow
all Safety Rules
and Instructions
Before Operating
This Equipment**

**25.0 HP
ELECTRIC START
48" MOWER
AUTOMATIC
GARDEN TRACTOR**

- **Assembly**
- **Operation**
- **Maintenance**
- **Service and Adjustments**
- **Repair Parts**

SAFETY RULES



SAFE OPERATION PRACTICES FOR RIDE-ON MOWERS



IMPORTANT: THIS CUTTING MACHINE IS CAPABLE OF AMPUTATING HANDS AND FEET AND THROWING OBJECTS. FAILURE TO OBSERVE THE FOLLOWING SAFETY INSTRUCTIONS COULD RESULT IN SERIOUS INJURY OR DEATH.

I. GENERAL OPERATION

- Read, understand, and follow all instructions in the manual and on the machine before starting.
- Only allow responsible adults, who are familiar with the instructions, to operate the machine.
- Clear the area of objects such as rocks, toys, wire, etc., which could be picked up and thrown by the blade.
- Be sure the area is clear of other people before mowing. Stop machine if anyone enters the area.
- Never carry passengers.
- Do not mow in reverse unless absolutely necessary. Always look down and behind before and while backing.
- Be aware of the mower discharge direction and do not point it at anyone. Do not operate the mower without either the entire grass catcher or the guard in place.
- Slow down before turning.
- Never leave a running machine unattended. Always turn off blades, set parking brake, stop engine, and remove keys before dismounting.
- Turn off blades when not mowing.
- Stop engine before removing grass catcher or unclogging chute.
- Mow only in daylight or good artificial light.
- Do not operate the machine while under the influence of alcohol or drugs.
- Watch for traffic when operating near or crossing roadways.
- Use extra care when loading or unloading the machine into a trailer or truck.
- Data indicates that operators, age 60 years and above, are involved in a large percentage of riding mower-related injuries. These operators should evaluate their ability to operate the riding mower safely enough to protect themselves and others from serious injury.
- Keep machine free of grass, leaves or other debris build-up which can touch hot exhaust / engine parts and burn. Do not allow the mower deck to plow leaves or other debris which can cause build-up to occur. Clean any oil or fuel spillage before operating or storing the machine. Allow machine to cool before storage.

II. SLOPE OPERATION

Slopes are a major factor related to loss-of-control and tipover accidents, which can result in severe injury or death. All slopes require extra caution. If you cannot back up the slope or if you feel uneasy on it, do not mow it.

DO:

- Mow up and down slopes, not across.
- Remove obstacles such as rocks, tree limbs, etc.
- Watch for holes, ruts, or bumps. Uneven terrain could overturn the machine. *Tall grass can hide obstacles.*
- Use slow speed. Choose a low gear so that you will not have to stop or shift while on the slope.
- Follow the manufacturer's recommendations for wheel weights or counterweights to improve stability.
- Use extra care with grass catchers or other attachments. These can change the stability of the machine.
- Keep all movement on the slopes *slow* and *gradual*. Do not make sudden changes in speed or direction.

- Avoid starting or stopping on a slope. If tires lose traction, disengage the blades and proceed slowly *straight* down the slope.

DO NOT:

- *Do not* turn on slopes unless necessary, and then, turn slowly and gradually downhill, if possible.
- *Do not* mow near drop-offs, ditches, or embankments. The mower could suddenly turn over if a wheel is over the edge of a cliff or ditch, or if an edge caves in.
- *Do not* mow on wet grass. Reduced traction could cause sliding.
- *Do not* try to stabilize the machine by putting your foot on the ground.
- *Do not* use grass catcher on steep slopes.

III. CHILDREN

Tragic accidents can occur if the operator is not alert to the presence of children. Children are often attracted to the machine and the mowing activity. *Never* assume that children will remain where you last saw them.

- Keep children out of the mowing area and under the watchful care of another responsible adult.
- Be alert and turn machine off if children enter the area.
- Before and when backing, look behind and *down* for small children.
- Never carry children. They may fall off and be seriously injured or interfere with safe machine operation.
- Never allow children to operate the machine.
- Use extra care when approaching blind corners, shrubs, trees, or other objects that may obscure vision.

IV. SERVICE

- Use extra care in handling gasoline and other fuels. They are flammable and vapors are explosive.
 - Use only an approved container.
 - Never remove gas cap or add fuel with the engine running. Allow engine to cool before refueling. Do not smoke.
 - Never refuel the machine indoors.
 - Never store the machine or fuel container inside where there is an open flame, such as a water heater.
- Never run a machine inside a closed area.
- Keep nuts and bolts, especially blade attachment bolts, tight and keep equipment in good condition.
- Never tamper with safety devices. Check their proper operation regularly.
- Keep machine free of grass, leaves, or other debris build-up. Clean oil or fuel spillage. Allow machine to cool before storing.
- Stop and inspect the equipment if you strike an object. Repair, if necessary, before restarting.
- Never make adjustments or repairs with the engine running.
- Grass catcher components are subject to wear, damage, and deterioration, which could expose moving parts or allow objects to be thrown. Frequently check components and replace with manufacturer's recommended parts, when necessary.
- Mower blades are sharp and can cut. Wrap the blade(s) or wear gloves, and use extra caution when servicing them.
- Check brake operation frequently. Adjust and service as required.

SAFETY RULES



SAFE OPERATION PRACTICES FOR RIDE-ON MOWERS



- Be sure the area is clear of other people before mowing. Stop machine if anyone enters the area.
- Never carry passengers or children even with the blades off.
- Do not mow in reverse unless absolutely necessary. Always look down and behind before and while backing.
- Never carry children. They may fall off and be seriously injured or interfere with safe machine operation.
- Keep children out of the mowing area and under the watchful care of another responsible adult.
- Be alert and turn machine off if children enter the area.
- Before and when backing, look behind and down for small children.
- Mow up and down slopes (15° Max), not across.
- Remove obstacles such as rocks, tree limbs, etc.
- Watch for holes, ruts, or bumps. Uneven terrain could overturn the machine. Tall grass can hide obstacles.
- Use slow speed. Choose a low gear so that you will not have to stop or shift while on the slope.
- Avoid starting or stopping on a slope. If tires lose traction, disengage the blades and proceed slowly straight down the slope.
- If machine stops while going uphill, disengage blades, shift into reverse and back down slowly.
- Do not turn on slopes unless necessary, and then, turn slowly and gradually downhill, if possible.



WARNING: Do not coast down a hill in neutral, you may lose control of the tractor.



WARNING: Tow only the attachments that are recommended by and comply with specifications of the manufacturer of your tractor. Use common sense when towing. Operate only at the lowest possible speed when on a slope. Too heavy of a load, while on a slope, is dangerous. Tires can lose traction with the ground and cause you to lose control of your tractor.



WARNING: In order to prevent accidental starting when setting up, transporting, adjusting or making repairs, always disconnect spark plug wire and place wire where it cannot contact spark plug.

TABLE OF CONTENTS

SAFETY RULES	2-3
PRODUCT SPECIFICATIONS	4
WARRANTY	4
CUSTOMER RESPONSIBILITIES	4
ASSEMBLY	6-10
OPERATION	11-16
MAINTENANCE SCHEDULE	17
MAINTENANCE	17-20

SERVICE AND ADJUSTMENTS	21-27
STORAGE	28
TROUBLESHOOTING	29-30
REPAIR PARTS - TRACTOR	32-49
REPAIR PARTS - ENGINE.....	50-57
PARTS ORDERING/SERVICE.....	BACK COVER

PRODUCT SPECIFICATIONS

Gasoline Capacity and type:	5.0 Gallons Unleaded Regular	
Oil Type (API-SF-SJ):	SAE 10W30 (above 32°F) SAE 5W-30 (below 32°F)	
Oil Capacity:	W/Filter:	4.0 Pints
	W/O Filter:	3.5 Pints
Spark Plug: (Gap: .030")	Champion RC12YC	
Ground Speed (MPH):	Forward:	5.8
	Reverse:	2.1
Tire Pressure:	Front:	14 PSI
	Rear:	10 PSI
Charging System:	15 AMPS @ 3600 RPM	
Battery:	AMP/HR:	35
	MIN. CCA:	280
	CASE SIZE:	U1R
Blade Bolt Torque:	45-55 FT. LBS.	

CONGRATULATIONS on your purchase of a tractor. It has been designed, engineered and manufactured to give you the best possible dependability and performance.

Should you experience any problem you cannot easily remedy, please contact your nearest authorized service center/department. We have competent, well-trained technicians and the proper tools to service or repair this tractor.

Please read and retain this manual. The instructions will enable you to assemble and maintain your tractor properly. Always observe the "SAFETY RULES".

MAINTENANCE AGREEMENT

A Maintenance Agreement is available on this product. Contact your nearest Sears store for details.

CUSTOMER RESPONSIBILITIES

- Read and observe the safety rules.
- Follow a regular schedule in maintaining, caring for and using your tractor.
- Follow the instructions under "Maintenance" and "Storage" sections of this owner's manual.

WARNING: This tractor is equipped with an internal combustion engine and should not be used on or near any unimproved forest-covered, brush-covered or grass-covered land unless the engine's exhaust system is equipped with a spark arrester meeting applicable local or state laws (if any). If a spark arrester is used, it should be maintained in effective working order by the operator.

A spark arrester for the muffler is available through your nearest authorized service center/department (See REPAIR PARTS section of this manual).

WARRANTY

LIMITED TWO (2) YEAR WARRANTY ON CRAFTSMAN TRACTOR (RIDING EQUIPMENT)

For two (2) years from date of purchase Sears Canada, Inc. will repair or replace at Sears option free of charge parts which are defective as a result of material or workmanship.

FULL ONE (1) YEAR WARRANTY ON BATTERY

For one (1) year from date of purchase, if any battery included with this riding equipment proves defective in material or workmanship and our testing determines the battery will not hold a charge, Sears will replace the battery at no charge.

COMMERCIAL OR RENTAL USE

Warranty on Riding Equipment used for commercial or rental purposes is limited to ninety (90) days.

This Warranty does NOT cover:

1. Pre-delivery set-up.
2. Tire replacement or repair caused by punctures from outside objects (such as nails, thorns, stumps, or glass).
3. Expendable items which become worn during normal use, such as blades, spark plug, air cleaners and belts.
4. Repairs necessary because of operator abuse or negligence, including damaged jackshaft or mandrel and the failure to operate and maintain the equipment according to the instructions contained in the Owner's Manual.
5. In Home service.

Warranty service is available by returning the Craftsman Riding Equipment to the nearest Sears Service Centre/Department in Canada. This warranty applies only while this product is in use in Canada.

This warranty is in addition to any statutory warranty and does not exclude or limit legal rights you may have but shall run concurrently with applicable provincial legislation. Furthermore, some provinces do NOT allow limitation on how long an implied warranty will last so the above limitations may not apply to you.

SEARS CANADA, INC., TORONTO, ONTARIO M5B 2B8

UNASSEMBLED PARTS

Steering Wheel

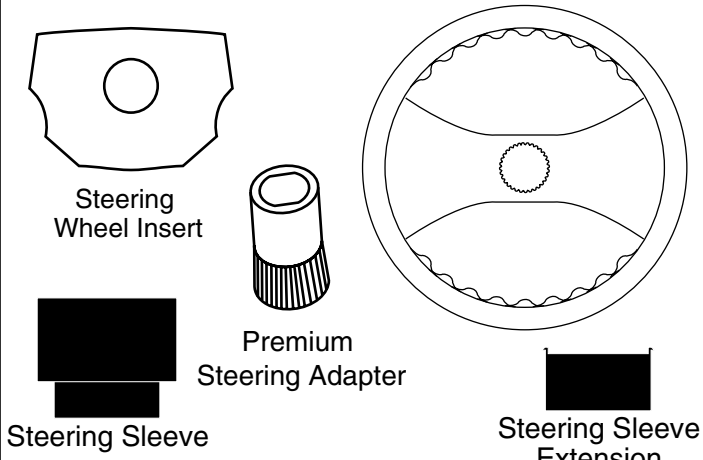

Gauge Wheels

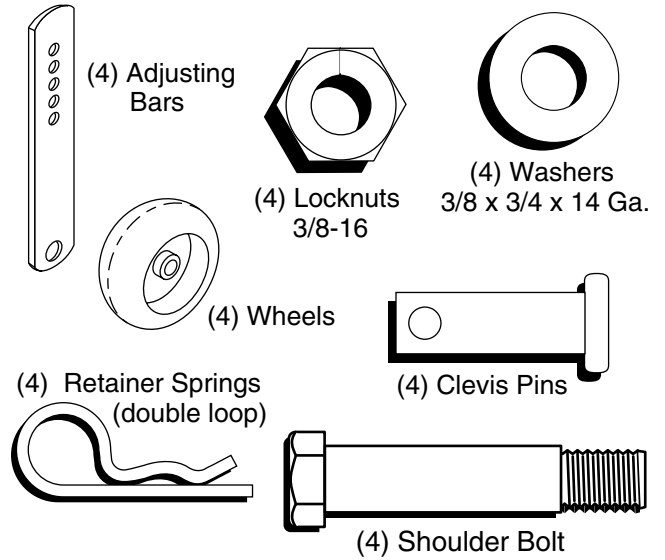

Seat

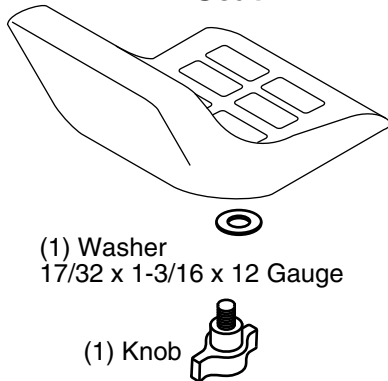

Nose Roller

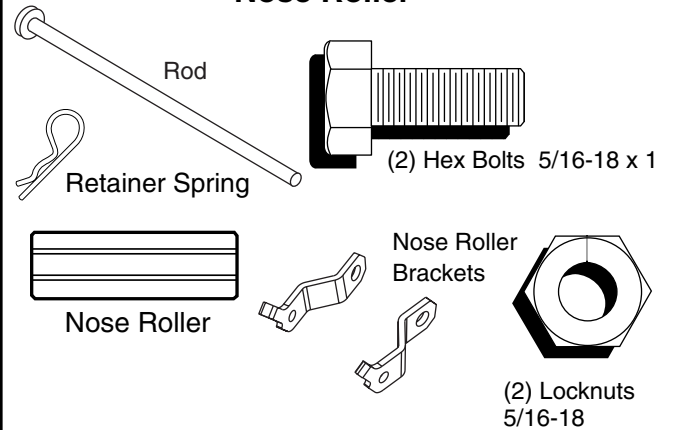

Battery

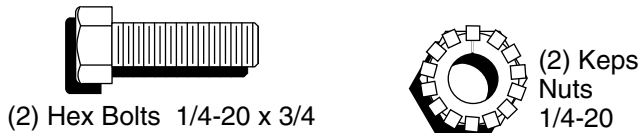

Mower

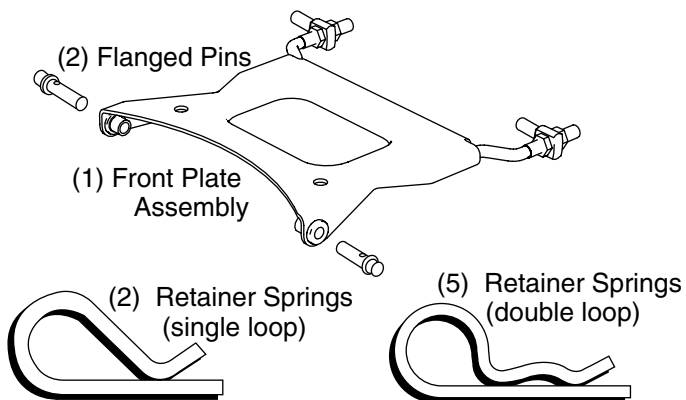

Mower Leveling Wrench

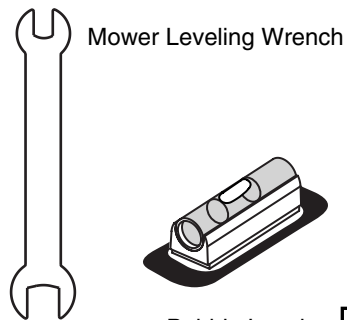

Keys



Slope Sheet

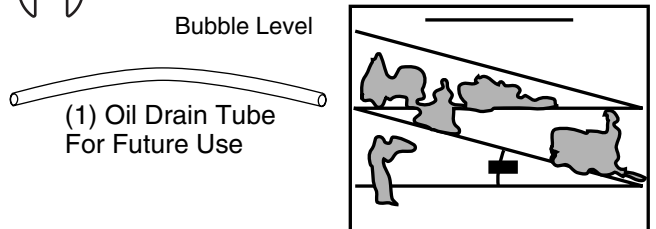

ASSEMBLY

Your new tractor has been assembled at the factory with exception of those parts left unassembled for shipping purposes. To ensure safe and proper operation of your tractor all parts and hardware you assemble must be tightened securely. Use the correct tools as necessary to insure proper tightness.

TOOLS REQUIRED FOR ASSEMBLY

A socket wrench set will make assembly easier. Standard wrench sizes are listed.

- (1) 1/2" wrench
- (1) Tire pressure gauge
- (1) 9/16" wrenches
- (1) Utility knife
- (1) Pliers
- (1) 3/4" socket w/drive ratchet

When right or left hand is mentioned in this manual, it means when you are in the operating position (seated behind the steering wheel).

TO REMOVE TRACTOR FROM CARTON

UNPACK CARTON

- Remove all accessible loose parts and parts cartons from carton.
- Cut along dotted lines on all four panels of carton. Remove end panels and lay side panels flat.
- Remove mower and packing materials.
- Check for any additional loose parts or cartons and remove.

BEFORE REMOVING TRACTOR FROM SKID

ATTACH STEERING WHEEL (See Fig. 1)

- Remove hex bolt, lock washer and large flat washer from steering shaft.
- Position front wheels of the tractor so they are pointing straight forward.
- Slide the steering sleeve over the steering shaft.
- Align tabs and press steering sleeve extension into bottom of steering wheel.
- Position steering wheel so cross bars are horizontal (left to right) and slide onto steering wheel adapter.
- Secure steering wheel to steering shaft with hex bolt, lock washer and large flat washer previously removed. Tighten securely.
- Snap steering wheel insert into center of steering wheel.
- Remove protective materials from tractor hood and grill.

IMPORTANT: CHECK FOR AND REMOVE ANY STAPLES IN SKID THAT MAY PUNCTURE TIRES WHERE TRACTOR IS TO ROLL OFF SKID.

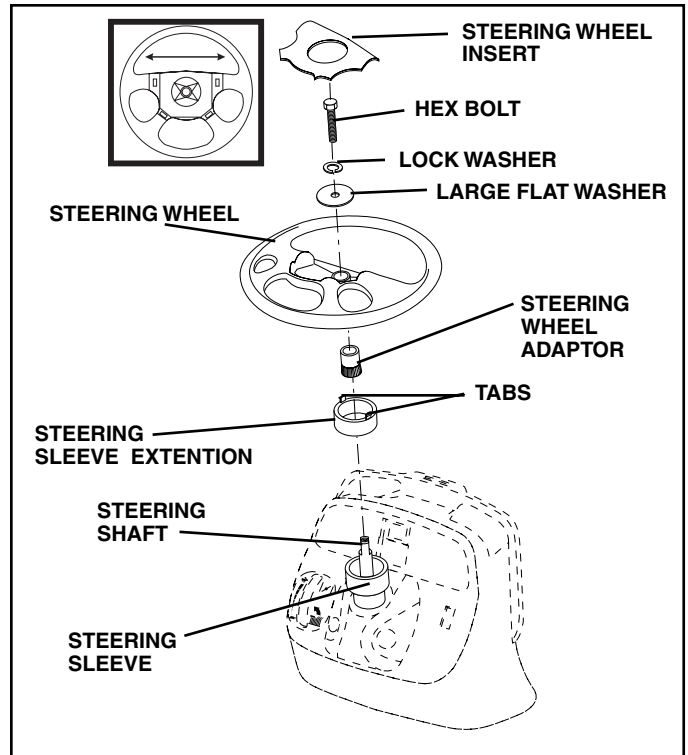

FIG. 1

HOW TO SET UP YOUR TRACTOR

CONNECT BATTERY (See Fig. 2)



CAUTION: Do not short battery terminals by allowing a wrench or any other object to contact both terminals at the same time. Before connecting battery, remove metal bracelets, wrist-watch bands, rings, etc.

Positive terminal must be connected first to prevent sparking from accidental grounding.

- Lift hood to raised position.
- Open terminal access doors, remove terminal protective caps and discard.
- If this battery is put into service after month and year indicated on label (label located between terminals) charge battery for minimum of one hour at 6-10 amps.
- First connect RED battery cable to positive (+) battery terminal with hex bolt and keps nut as shown. Tighten securely.
- Connect BLACK grounding cable to negative (-) battery terminal with remaining hex bolt and keps nut. Tighten securely.
- Close terminal access doors.

ASSEMBLY

Use terminal access doors for:

- Inspection for secure connections (to tighten hardware).
- Inspection for corrosion.
- Testing battery.
- Jumping (if required).
- Periodic charging.

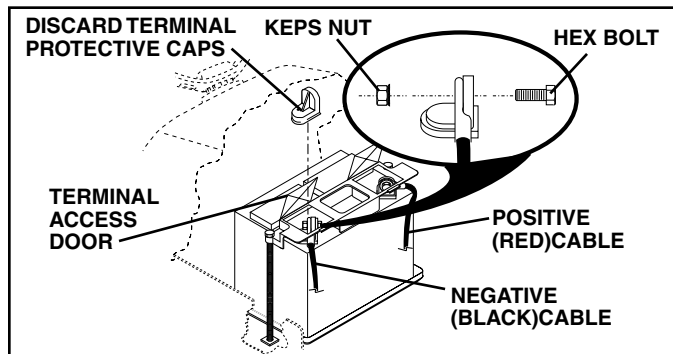

FIG. 2

INSTALL SEAT (See Fig. 3)

Adjust seat before tightening adjustment knob.

- Remove adjustment knob and flat washer securing seat to cardboard packing and set aside for assembly of seat to tractor.
- Pivot seat upward and remove from the cardboard packing. Remove the cardboard packing and discard.
- Place seat on seat pan so head of shoulder bolts are positioned over the large slotted holes in pan.
- Push down on seat to engage shoulder bolts in slots and pull seat towards rear of tractor.
- Pivot seat and pan forward and assemble adjustment knob and flat washer loosely. Do not tighten.
- Lower seat into operating position and sit in seat.
- Slide seat until a comfortable position is reached which allows you to press clutch/brake pedal all the way down.
- Get off seat without moving its adjusted position.
- Raise seat and tighten adjustment knob securely.

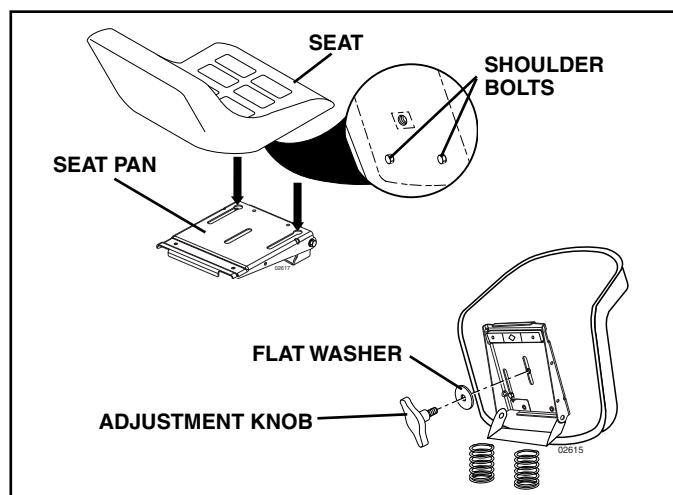

FIG. 3

NOTE: You may now roll or drive your tractor off the skid. Follow the appropriate instruction below to remove the tractor from the skid.

TO ROLL TRACTOR OFF SKID (See Operation section for location and function of controls)

- Press lift lever plunger and raise attachment lift lever to its highest position.
- Release parking brake by depressing brake pedal.
- Place freewheel control in "transmission disengaged position" (See "TO TRANSPORT" in the Operation section of this manual).
- Roll tractor forward off skid.

TO DRIVE TRACTOR OFF SKID (See Operation section for location and function of controls)

WARNING: Before starting, read, understand and follow all instructions in the Operation section of this manual. Be sure tractor is in a well-ventilated area. Be sure the area in front of tractor is clear of other people and objects.

- Be sure all the above assembly steps have been completed.
- Check engine oil level and fill fuel tank with gasoline.
- Place freewheel control in "transmission engaged" position (see "TO TRANSPORT" in Operation section of this manual).
- Sit on seat in operating position, depress brake pedal and set the parking brake.
- Place motion control lever in neutral (N) position.
- Press lift lever plunger and raise attachment lift lever to its highest position.
- Start the engine. After engine has started, move throttle control to idle position.
- Release parking brake.
- Slowly move the motion control lever forward and slowly drive tractor off skid.
- Apply brake to stop tractor, set parking brake and place motion control lever in neutral position.
- Turn ignition key to "STOP" position.

Continue with the instructions that follow.

ASSEMBLY

ASSEMBLE GAUGE WHEELS TO MOWER DECK (See Fig. 4)

The gauge wheels are designed to keep the mower deck in proper position when operating mower. Be sure they are properly adjusted to ensure optimum mower performance.

- Slide gauge wheel bar down into bracket channel, Be sure that gauge wheel bar aligning holes are on top. Assemble gauge wheels as shown using shoulder bolts, 3/8 washers and 3/8-16 center locknuts and tighten securely.
- For ease of mower to tractor assembly, raise gauge wheels to highest position and retain with clevis pins and spring retainers.
- Adjust gauge wheels before operating mower. See "TO ADJUST GAUGE WHEELS" in the Operation section of this manual.

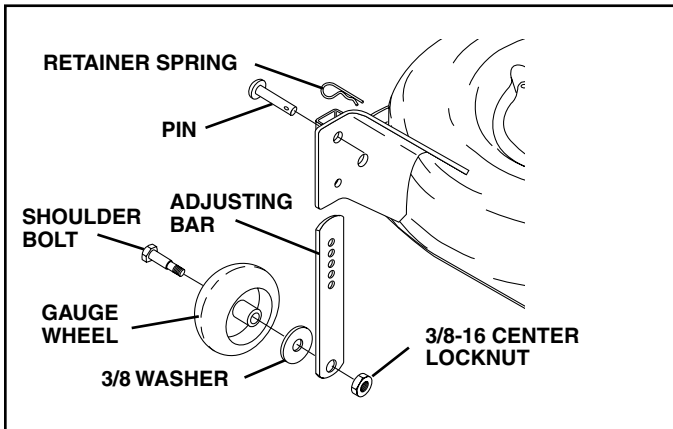

FIG. 4

TO ATTACH NOSE ROLLER (See Fig. 5)

- Assemble brackets "A" and "B" to the inside of mower mounting brackets as shown. Tighten securely.

NOTE: Be sure bracket tabs are positioned in tab holes in mower brackets.

- Position nose roller between brackets and install rod and retainer spring.

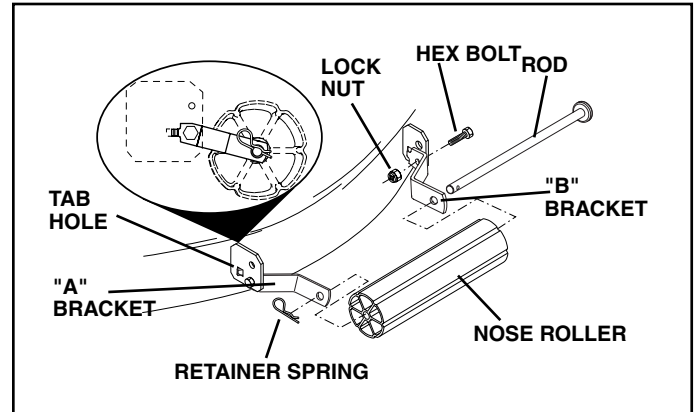

FIG. 5

ASSEMBLY

INSTALL MOWER AND DRIVE BELT (See Figs. 6 and 7)

Be sure tractor is on level surface and mower suspension arms are raised with attachment lift control. Engage parking brake.

- Cut and remove ties securing anti-sway bar and belts. Swing anti-sway bar to left side of mower deck.
- Slide mower under tractor with deflector shield to right side of tractor.

IMPORTANT: Check belt for proper routing in all mower pulley grooves.

- If equipped, turn height adjustment knob counter-clockwise until it stops.
- Lower mower linkage with attachment lift control.
- Be sure belt tension rod is in disengaged position.
- Install belt into electric clutch pulley groove.
- Place the suspension arms on outward pointing deck pins. Retain with double loop retainer spring with loops up as shown.
- Install front plate assembly to tractor suspension brackets and retain with single loop retainer springs as shown.

- Position front plate assembly between front mower brackets. Raise deck and plate assembly to align holes and insert flanged pins. Secure pins with double loop retainer springs between the plate assembly and mower brackets.

NOTE: To assist in locating hole in flanged pin, the hole in pin is inline with notch on head of pin. If necessary, move mower side-to-side to give space between plate and mower brackets.

IMPORTANT: Check belt for proper routing in all mower pulley grooves.

- Engage belt tension rod by pushing rod into locking bracket.



CAUTION: Belt tension rod is spring loaded. Have a tight grip on rod and engage slowly.

- Connect anti-sway bar to chassis bracket under left footrest and retain with double loop retainer spring.
- If equipped, turn height adjustment knob clockwise to remove slack from mower suspension.
- Raise deck to highest position.
- Adjust gauge wheels before operating mower as shown in the Operation section of this manual.

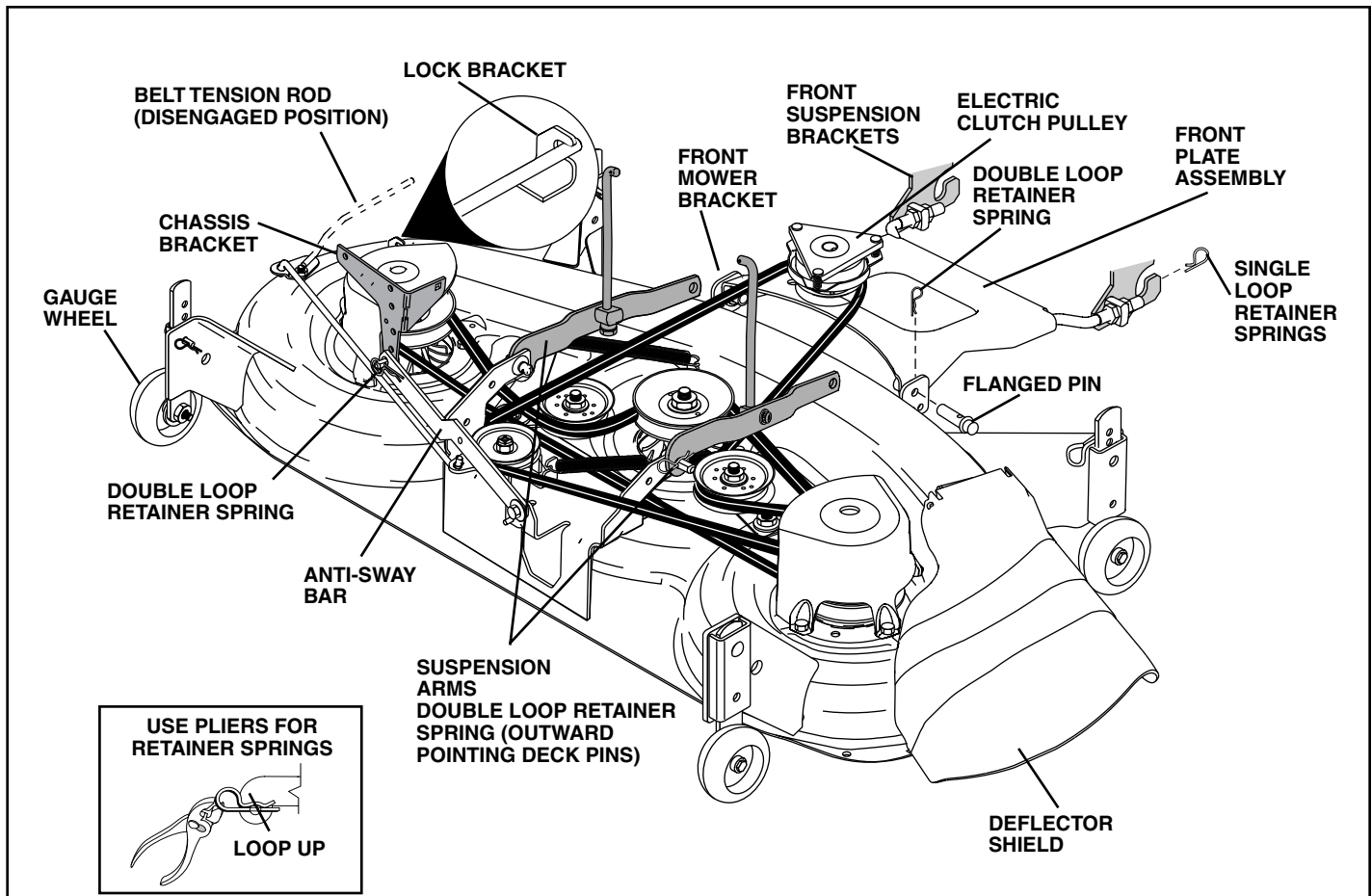

FIG. 6

ASSEMBLY

CHECK TIRE PRESSURE

The tires on your tractor were overinflated at the factory for shipping purposes. Correct tire pressure is important for best cutting performance.

- Reduce tire pressure to PSI shown in "PRODUCT SPECIFICATIONS" section of this manual.

CHECK MOWER LEVELNESS

For best cutting results, mower should be properly leveled. See "TO LEVEL MOWER HOUSING" in the Service and Adjustments section of this manual.

CHECK FOR PROPER POSITION OF ALL BELTS

See the figures that are shown for replacing motion, mower drive, and mower blade drive belts in the Service and Adjustments section of this manual. Verify that the belts are routed correctly.

✓ CHECKLIST

BEFORE YOU OPERATE AND ENJOY YOUR NEW TRACTOR, WE WISH TO ASSURE THAT YOU RECEIVE THE BEST PERFORMANCE AND SATISFACTION FROM THIS QUALITY PRODUCT.

PLEASE REVIEW THE FOLLOWING CHECKLIST:

- ✓ All assembly instructions have been completed.
- ✓ No remaining loose parts in carton.
- ✓ Battery is properly prepared and charged. (Minimum 1 hour at 6 amps).
- ✓ Seat is adjusted comfortably and tightened securely.
- ✓ All tires are properly inflated. (For shipping purposes, the tires were overinflated at the factory).
- ✓ Be sure mower deck is properly leveled side-to-side/front-to-rear for best cutting results. (Tires must be properly inflated for leveling).
- ✓ Check mower and drive belts. Be sure they are routed properly around pulleys and inside all belt keepers.
- ✓ Check wiring. See that all connections are still secure and wires are properly clamped.
- ✓ Before driving tractor, be sure freewheel control is in drive position.

WHILE LEARNING HOW TO USE YOUR TRACTOR, PAY EXTRA ATTENTION TO THE FOLLOWING IMPORTANT ITEMS:

- ✓ Engine oil is at proper level.
- ✓ Fuel tank is filled with fresh, clean, regular unleaded gasoline.
- ✓ Become familiar with all controls - their location and function. Operate them before you start the engine.
- ✓ Be sure brake system is in safe operating condition.
- ✓ It is important to purge the transmission before operating your tractor for the first time. Follow proper starting and transmission purging instructions (See "TO START ENGINE" and "PURGE TRANSMISSION" in the Operation section of this manual).

OPERATION

These symbols may appear on your tractor or in literature supplied with the product. Learn and understand their meaning.

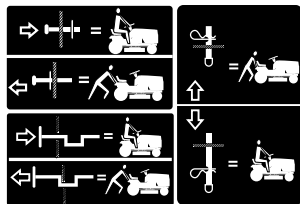
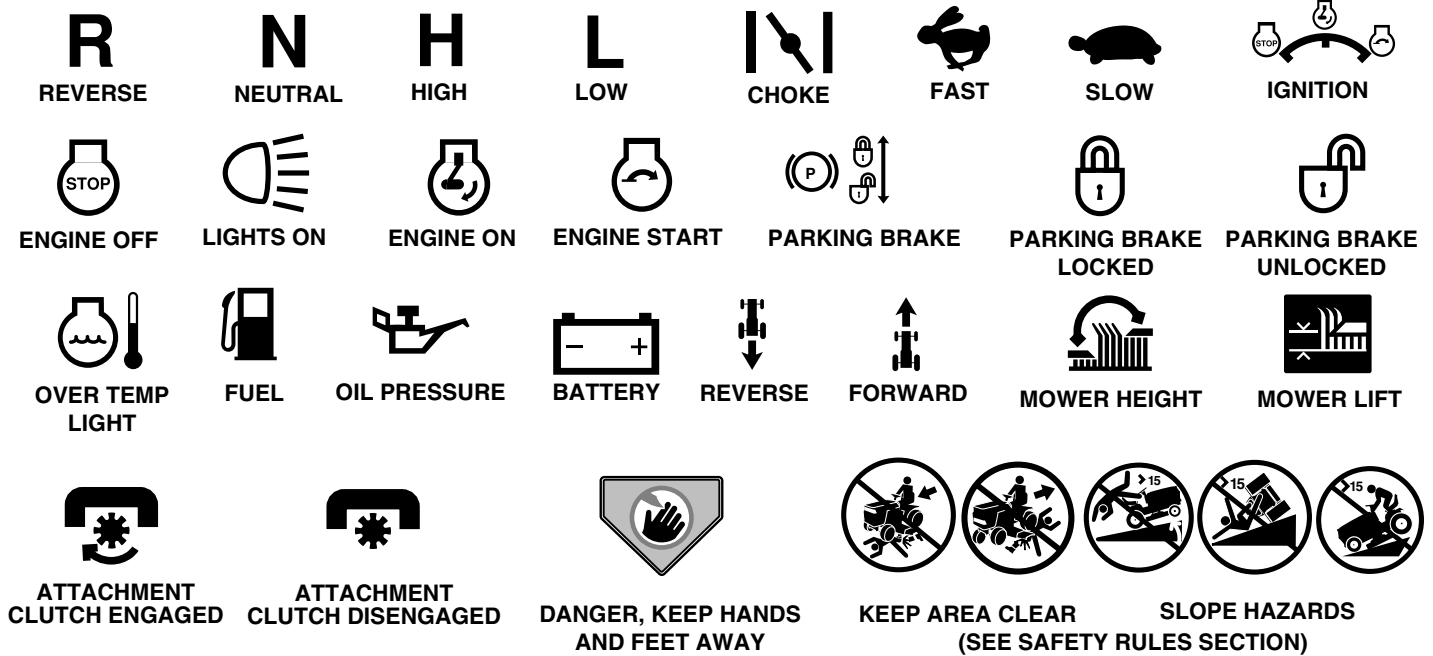

FREE WHEEL
(Automatic Models only)



Failure to follow instructions could result in serious injury or death. The safety alert symbol is used to identify safety information about hazards which can result in death, serious injury and/or property damage.



DANGER indicates a hazard which, if not avoided, will result in death or serious injury.



WARNING indicates a hazard which, if not avoided, could result in death or serious injury.



CAUTION indicates a hazard which, if not avoided, might result in minor or moderate injury.

CAUTION when used **without** the alert symbol, indicates a situation that **could result in damage to the tractor and/or engine.**



HOT SURFACES indicates a hazard which, if not avoided, **could result in death, serious injury and/or property damage.**



FIRE indicates a hazard which, if not avoided, **could result in death, serious injury and/or property damage.**

OPERATION

KNOW YOUR TRACTOR

READ THIS OWNER'S MANUAL AND SAFETY RULES BEFORE OPERATING YOUR TRACTOR.

Compare the illustrations with your tractor to familiarize yourself with the location of various controls and adjustments. Save this manual for future reference.

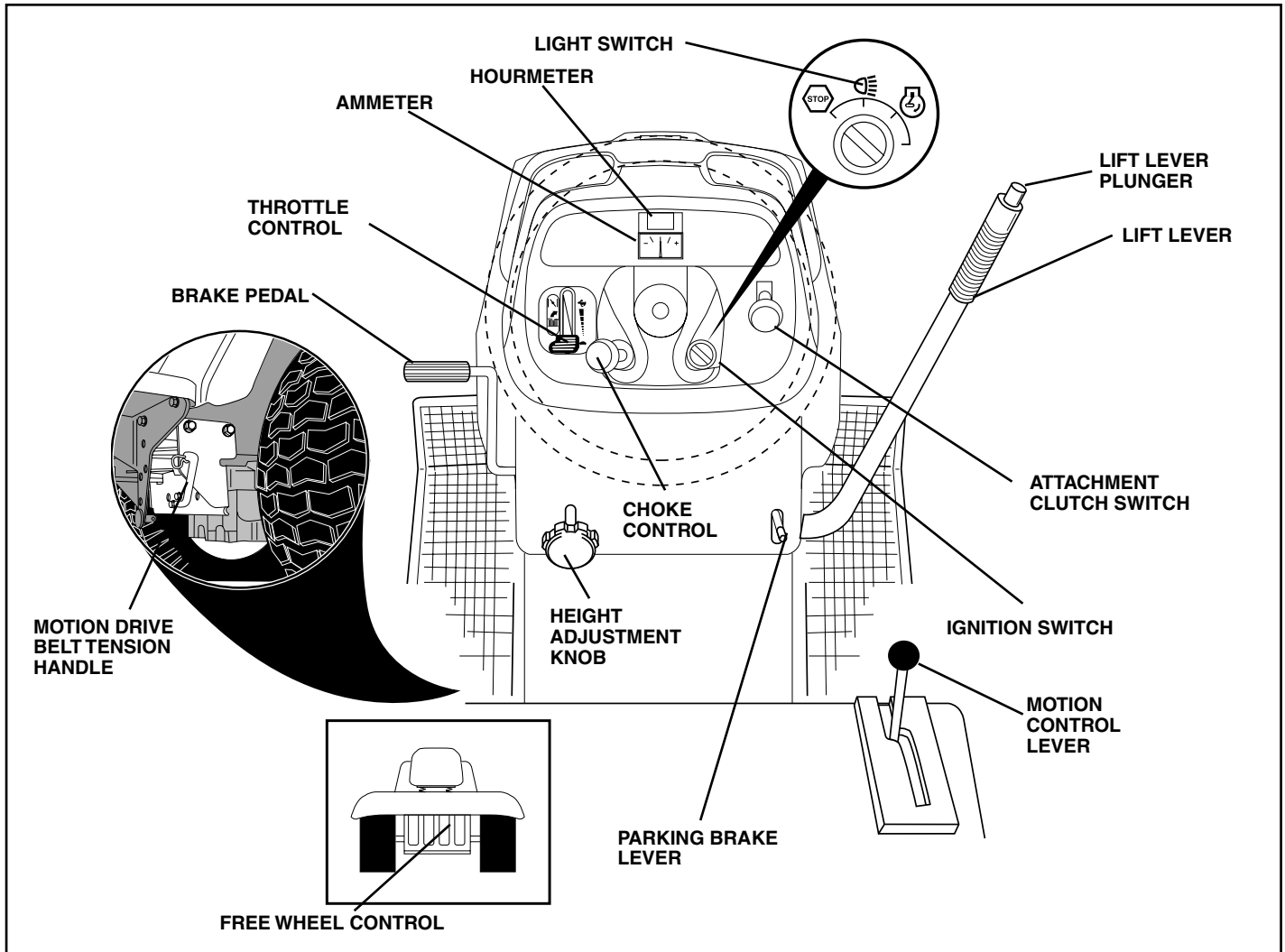

FIG. 7

Our tractors conform to the safety standards of the American National Standards Institute.

ATTACHMENT CLUTCH SWITCH - Used to engage mower blades or other attachments mounted to your tractor.

LIFT LEVER - Used to raise and lower mower deck or other attachments mounted to your tractor.

LIFT LEVER PLUNGER - Used to release attachment lift lever when changing its position.

BRAKE PEDAL - Used for braking the tractor and starting the engine.

MOTION CONTROL - Selects the speed and direction of tractor.

CHOKE CONTROL - Used when starting a cold engine.

AMMETER - Indicates charging (+) or discharging (-) of battery.

HOURMETER - Indicates hours of operation.

LIGHT SWITCH - Turns the headlights on and off.

THROTTLE CONTROL - Used to control engine speed.

FREEWHEEL CONTROL - Disengages transmission for pushing or slowly towing the tractor with the engine off.

IGNITION SWITCH - Used to start and stop the engine.

PARKING BRAKE LEVER - Locks brake pedal into the brake position.

HEIGHT ADJUSTMENT KNOB - Used to adjust the mower height.

MOTION DRIVE BELT TENSION HANDLE - Used when changing motion drive belt and, if necessary, starting engine under extremely cold conditions.

OPERATION



The operation of any tractor can result in foreign objects thrown into the eyes, which can result in severe eye damage. Always wear safety glasses or eye shields while operating your tractor or performing any adjustments or repairs. We recommend a wide vision safety mask over spectacles or standard safety glasses.

HOW TO USE YOUR TRACTOR

TO SET PARKING BRAKE (See Fig. 8)

Your tractor is equipped with an operator presence sensing switch. When engine is running, any attempt by the operator to leave the seat without first setting the parking brake will shut off the engine.

- Depress brake pedal into full "BRAKE" position and hold.
- Place parking brake lever in "ENGAGED" position and release pressure from brake pedal. Pedal should remain in "BRAKE" position. Make sure parking brake will hold tractor secure.

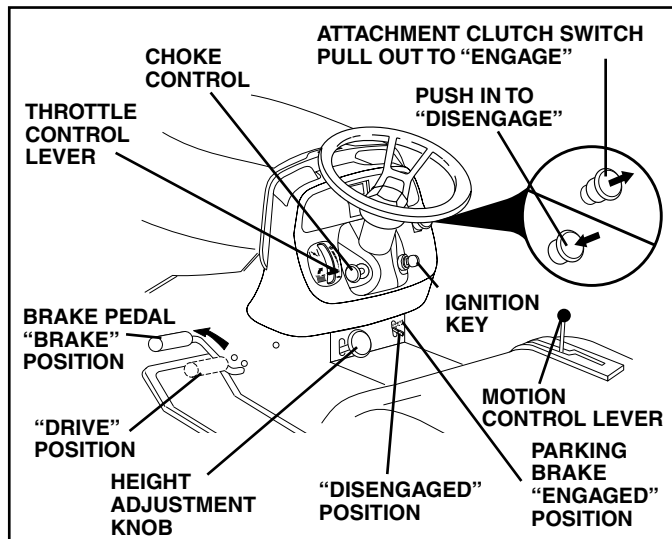

FIG. 8

STOPPING (See Fig. 8)

MOWER BLADES -

- To stop mower blades, move attachment clutch switch to "DISENGAGED" position.

GROUND DRIVE -

- To stop ground drive, depress brake pedal into full "BRAKE" position.

IMPORTANT: THE MOTION CONTROL LEVER RETURNS TO NEUTRAL (N) POSITION WHEN THE BRAKE PEDAL IS FULLY DEPRESSED.

ENGINE -

- Move throttle control between half and full speed (fast) position.

NOTE: Failure to move throttle control between half and full speed (fast) position, before stopping may cause engine to "backfire".

- Turn ignition key to "OFF" position and remove key. Always remove key when leaving tractor to prevent unauthorized use.
- Never use choke to stop engine.

IMPORTANT: LEAVING THE IGNITION SWITCH IN ANY POSITION OTHER THAN "OFF" WILL CAUSE THE BATTERY TO BE DISCHARGED, (DEAD).

NOTE: Under certain conditions when tractor is standing idle with the engine running, hot engine exhaust gases may cause "browning" of grass. To eliminate this possibility, always stop engine when stopping tractor on grass areas.



CAUTION: Always stop tractor completely, as described above, before leaving the operator's position; to empty grass catcher, etc.

TO USE THROTTLE CONTROL (See Fig. 8)

Always operate engine at full throttle.

- Operating engine at less than full throttle reduces the battery charging rate.
- Full throttle offers the best mower performance.

TO USE CHOKE CONTROL (See Fig. 8)

Use choke control whenever you are starting a cold engine. Do not use to start a warm engine.

- To engage choke control, pull knob out. Slowly push knob in to disengage.

TO MOVE FORWARD AND BACKWARD (See Fig. 8)

CAUTION: Do not attempt to operate motion control lever when the parking brake is set or when the brake pedal is depressed. Doing so may result in misadjustment to the drive control system.

The direction and speed of movement is controlled by the motion control lever.

- Start tractor with motion control lever in neutral (N) position.
- Release parking brake.
- Slowly move motion control lever to desired position.

TO ADJUST MOWER CUTTING HEIGHT (See Fig. 8)

The cutting height is controlled by turning the height adjustment knob in desired direction.

- Turn knob clockwise (↻) to raise cutting height.
- Turn knob counterclockwise (↺) to lower cutting height.

The cutting height range is approximately 1-1/2" to 4-1/2". The heights are measured from the ground to the blade tip with the engine not running. These heights are approximate and may vary depending upon soil conditions, height of grass and types of grass being mowed.

- The average lawn should be cut to approximately 2-1/2 inches during the cool season and to over 3 inches during hot months. For healthier and better looking lawns, mow often and after moderate growth.
- For best cutting performance, grass over 6 inches in height should be mowed twice. Make the first cut relatively high; the second to desired height.

OPERATION

TO ADJUST GAUGE WHEELS (See Fig. 9)

Gauge wheels are properly adjusted when they are slightly off the ground when mower is at the desired cutting height in operating position. Gauge wheels then keep the deck in proper position to help prevent scalping in most terrain conditions.

NOTE: Adjust gauge wheels with tractor on a flat level surface.

- Adjust mower to desired cutting height (See “TO ADJUST MOWER CUTTING HEIGHT” in the Operation section of this manual).
- Remove retainer spring and clevis pin which secure each gauge wheel bar.
- Lower gauge wheels to ground. Raise gauge wheels slightly to align holes in bracket and gauge wheel bar and insert clevis pin. Gauge wheels should be slightly off the ground.
- Replace retainer spring into clevis pin.
- Be sure all gauge wheels are in the same setting.

IMPORTANT: BE SURE TO READJUST GAUGE WHEELS IF YOU CHANGE THE CUTTING HEIGHT OF THE MOWER DECK.

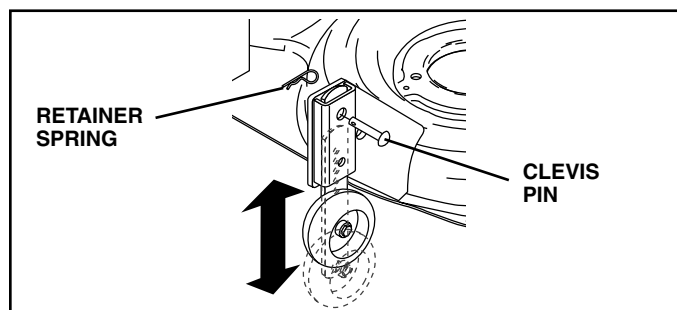

FIG. 9

TO OPERATE MOWER (See Fig. 10)

Your tractor is equipped with an operator presence sensing switch. Any attempt by the operator to leave the seat with the engine running and the attachment clutch engaged will shut off the engine.

- Select desired height of cut.
- Lower mower with attachment lift control.
- Start mower blades by engaging attachment clutch control.
- TO STOP MOWER BLADES - disengage attachment clutch control.



CAUTION: Do not operate the mower without either the entire grass catcher, on mowers so equipped, or the deflector shield in place.

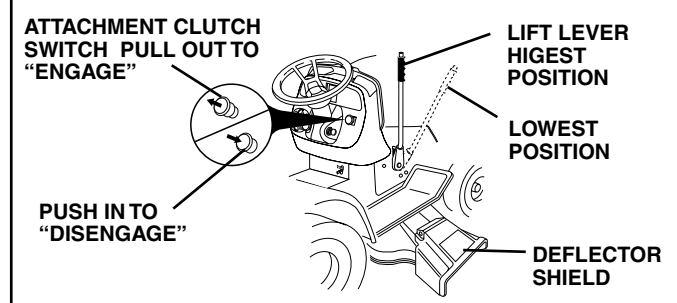

FIG. 10

TO OPERATE ON HILLS



WARNING: Do not drive up or down hills with slopes greater than 15° and do not drive across any slope.

- Choose the slowest speed before starting up or down hills.
- Avoid stopping or changing speed on hills.
- If stopping is absolutely necessary, push brake pedal quickly to brake position and engage parking brake.

IMPORTANT: THE MOTION CONTROL LEVER RETURNS TO NEUTRAL (N) POSITION WHEN THE BRAKE PEDAL IS FULLY DEPRESSED.

- To restart movement, slowly release parking brake and brake pedal.
- Slowly move motion control lever to slowest setting.
- Make all turns slowly.

TO TRANSPORT (See Figs. 7 and 11)

When pushing or towing your tractor, be sure to disengage transmission by placing freewheel control in freewheeling position. Free wheel control is located at the rear drawbar of tractor.

- Raise attachment lift to highest position with attachment lift control.
- Pull freewheel control out and into the slot and release so it is held in the disengaged position.
- Do not push or tow tractor at more than two (2) MPH.
- To reengage transmission, reverse above procedure.

NOTE: To protect hood from damage when transporting your tractor on a truck or a trailer, be sure hood is closed and secured to tractor. Use an appropriate means of tying hood to tractor (rope, cord, etc.).

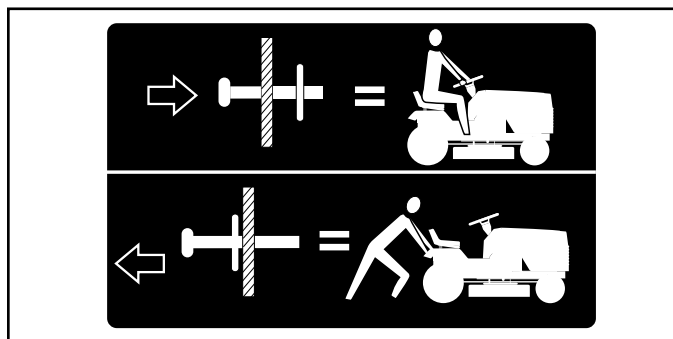

FIG. 11

TOWING CARTS AND OTHER ATTACHMENTS

Tow only the attachments that are recommended by and comply with specifications of the manufacturer of your tractor. Use common sense when towing. Too heavy of a load, while on a slope, is dangerous. Tires can lose traction with the ground and cause you to lose control of your tractor.

OPERATION

BEFORE STARTING THE ENGINE

CHECK ENGINE OIL LEVEL

The engine in your tractor has been shipped, from the factory, already filled with summer weight oil.

- Check engine oil with tractor on level ground.
- Unthread and remove oil fill cap/dipstick; wipe oil off. Reinsert the dipstick into the tube and rest oil fill cap on the tube. Do not thread the cap onto the tube. Remove and read oil level. If necessary, add oil until "FULL" mark on dipstick is reached. Do not overfill.
- For cold weather operation you should change oil for easier starting (See "OIL VISCOSITY CHART" in the Maintenance section of this manual).
- To change engine oil, see the Maintenance section in this manual.

ADD GASOLINE

- Fill fuel tank to bottom of filler neck. Do not overfill. Use fresh, clean, regular unleaded gasoline with a minimum of 87 octane. (Use of leaded gasoline will increase carbon and lead oxide deposits and reduce valve life). Do not mix oil with gasoline. Purchase fuel in quantities that can be used within 30 days to assure fuel freshness.



CAUTION: Wipe off any spilled oil or fuel. Do not store, spill or use gasoline near an open flame.

IMPORTANT: WHEN OPERATING IN TEMPERATURES BELOW 32°F (0°C), USE FRESH, CLEAN WINTER GRADE GASOLINE TO HELP INSURE GOOD COLD WEATHER STARTING.

CAUTION: Alcohol blended fuels (called gasohol or using ethanol or methanol) can attract moisture which leads to separation and formation of acids during storage. Acidic gas can damage the fuel system of an engine while in storage. To avoid engine problems, the fuel system should be emptied before storage of 30 days or longer. Drain the gas tank, start the engine and let it run until the fuel lines and carburetor are empty. Use fresh fuel next season. See Storage Instructions for additional information. Never use engine or carburetor cleaner products in the fuel tank or permanent damage may occur.

TO START ENGINE (See Fig. 8)

When starting the engine for the first time or if the engine has run out of fuel, it will take extra cranking time to move fuel from the tank to the engine.

- Be sure freewheel control is in the transmission engaged position.
- Sit on seat in operating position, depress brake pedal and set parking brake.
- Move attachment clutch to "DISENGAGED" position.
- Move throttle control to fast position
- Pull choke control out for a cold engine start attempt. For a warm engine start attempt the choke control may not be needed.

NOTE: Before starting, read the warm and cold starting procedures below.

- Insert key into ignition and turn key clockwise to "START" position and release key as soon as engine starts. Do not run starter continuously for more than fifteen seconds per minute. If the engine does not start after several attempts, push choke control in, wait a few minutes and try again. If engine still does not start, pull the choke control out and retry.

WARM WEATHER STARTING (50° F and above)

- When engine starts, slowly push choke control in until the engine begins to run smoothly. If the engine starts to run roughly, pull the choke control out slightly for a few seconds and then continue to push the control in slowly.
- The attachments and ground drive can now be used. If the engine does not accept the load, restart the engine and allow it to warm up for one minute using the choke as described above.

COLD WEATHER STARTING (50° F and below)

- When engine starts, slowly push choke control in until the engine begins to run smoothly. Continue to push the choke control in small steps allowing the engine to accept small changes in speed and load, until the choke control is fully in. If the engine starts to run roughly, pull the choke control out slightly for a few seconds and then continue to push the control in slowly. This may require an engine warm-up period from several seconds to several minutes, depending on the temperature.

NOTE: In extreme cold conditions, if engine will not start, you may need to disengage the motion drive belt as follows:

- Be sure parking brake is engaged.
- Remove retainer spring from the drive belt tension handle to relieve belt tension.
- Start engine and allow it to warm up for three (3) minutes.
- Shut-off engine and engage parking brake.
- Engage drive belt tension handle and replace the retainer spring.

AUTOMATIC TRANSMISSION WARM UP

- Before driving the unit in cold weather, the transmission should be warmed up as follows:
 - Be sure the tractor is on level ground.
 - Place the motion control lever in neutral.
 - Release the parking brake and let the brake slowly return to operating position.
 - Allow one minute for transmission to warm up. This can be done during the engine warm up period.
- The attachments can be used during the engine warm-up period after the transmission has been warmed up and may require the choke control be pulled out slightly.

NOTE: If at a high altitude (above 3000 feet) or in cold temperatures (below 32 F) the carburetor fuel mixture may need to be adjusted for best engine performance. See "TO ADJUST CARBURETOR" in the Service and Adjustments section of this manual.

OPERATION

PURGE TRANSMISSION



CAUTION: Never engage or disengage freewheel lever while the engine is running.

To ensure proper operation and performance, it is recommended that the transmission be purged before operating tractor for the first time. This procedure will remove any trapped air inside the transmission which may have developed during shipping of your tractor.

IMPORTANT: SHOULD YOUR TRANSMISSION REQUIRE REMOVAL FOR SERVICE OR REPLACEMENT, IT SHOULD BE PURGED AFTER REINSTALLATION BEFORE OPERATING THE TRACTOR.

- Place tractor safely on level surface with engine off and parking brake set.
- Disengage transmission by placing freewheel control in freewheeling position (See “TO TRANSPORT” in this section of manual).
- Sitting in the tractor seat, start engine. After the engine is running, move throttle control to slow position. Disengage parking brake
- Move motion control lever to full forward position and hold for five (5) seconds. Move lever to full reverse position and hold for five (5) seconds. Repeat this procedure three (3) times.

NOTE: During this procedure there will be no movement of drive wheels. The air is being removed from hydraulic drive system.

- Move motion control lever to neutral (N) position. Shut-off engine and set parking brake.
- Engage transmission by placing freewheel control in driving position (See “TO TRANSPORT” in this section of manual).
- Sitting in the tractor seat, start engine. After the engine is running, move throttle control to half (1/2) speed. Disengage parking brake.
- Slowly move motion control lever forward, after the tractor moves approximately five (5) feet, slowly move motion control lever to reverse position. After the tractor moves approximately five (5) feet return the motion control lever to the neutral (N) position. Repeat this procedure with the motion control lever three (3) times.
- Your transmission is now purged and now ready for normal operation.

MOWING TIPS

- Tire chains cannot be used when the mower housing is attached to tractor.
- Mower should be properly leveled for best mowing performance. See “TO LEVEL MOWER HOUSING” in the Service and Adjustments section of this manual.
- The left hand side of mower should be used for trimming.
- Drive so that clippings are discharged onto the area that has been cut. Have the cut area to the right of the tractor. This will result in a more even distribution of clippings and more uniform cutting.
- When mowing large areas, start by turning to the right so that clippings will discharge away from shrubs, fences, driveways, etc. After one or two rounds, mow in the opposite direction making left hand turns until finished (See Fig. 12).

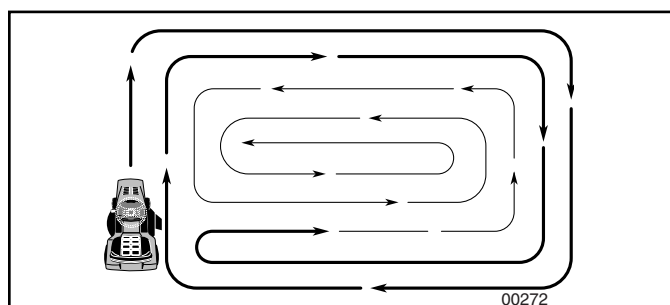

FIG. 12

- If grass is extremely tall, it should be mowed twice to reduce load and possible fire hazard from dried clippings. Make first cut relatively high; the second to the desired height.
- Do not mow grass when it is wet. Wet grass will plug mower and leave undesirable clumps. Allow grass to dry before mowing.
- **Always operate engine at full throttle when mowing** to assure better mowing performance and proper discharge of material. Regulate ground speed by selecting a low enough gear to give the mower cutting performance as well as the quality of cut desired.
- When operating attachments, select a ground speed that will suit the terrain and give best performance of the attachment being used.

MAINTENANCE

MAINTENANCE SCHEDULE		SERVICE INTERVALS							SERVICE DATES	
		BEFORE EACH USE	EVERY 8 HOURS	EVERY 25 HOURS	EVERY 50 HOURS	EVERY 100 HOURS	EVERY SEASON	BEFORE STORAGE		
TRACTOR	Check Brake Operation	✓	✓							
	Check Tire Pressure	✓	✓							
	Check Operator Presence and Interlock Systems	✓								
	Check for Loose Fasteners	✓				✓ ₅		✓		
	Sharpen/Replace Mower Blades			✓ ₃						
	Lubrication Chart			✓				✓		
	Check Battery Level			✓ ₄						
	Clean Battery and Terminals			✓				✓		
	Check Transaxle Cooling			✓						
	Check V-Belts					✓				
ENGINE	Check Engine Oil Level	✓	✓							
	Change Engine Oil (with oil filter)				✓ _{1,2}			✓		
	Change Engine Oil (without oil filter)			✓ _{1,2}				✓		
	Clean Air Filter			✓ ₂						
	Clean Air Screen			✓ ₂						
	Inspect Muffler/Spark Arrester				✓					
	Replace Oil Filter (If equipped)					✓ _{1,2}				
	Clean Engine Cooling Fins					✓ ₂				
	Replace Spark Plug					✓	✓			
	Replace Air Filter Paper Cartridge					✓ ₂				
Replace Fuel Filter							✓			

1 - Change more often when operating under a heavy load or in high ambient temperatures.
2 - Service more often when operating in dirty or dusty conditions.

3 - Replace blades more often when mowing in sandy soil.
4 - Not required if equipped with maintenance-free battery.
5 - Tighten front axle pivot bolt to 35 ft.-lbs. maximum. Do not overtighten.

maint_sch-tractor-new1

GENERAL RECOMMENDATIONS

The warranty on this tractor does not cover items that have been subjected to operator abuse or negligence. To receive full value from the warranty, operator must maintain tractor as instructed in this manual.

Some adjustments will need to be made periodically to properly maintain your tractor.

All adjustments in the Service and Adjustments section of this manual should be checked at least once each season.

- Once a year you should replace the spark plug, clean or replace air filter, and check blades and belts for wear. A new spark plug and clean air filter assure proper air-fuel mixture and help your engine run better and last longer.

BEFORE EACH USE

- Check engine oil level.
- Check brake operation.
- Check tire pressure.
- Check operator presence and interlock systems for proper operation.
- Check for loose fasteners.

LUBRICATION CHART

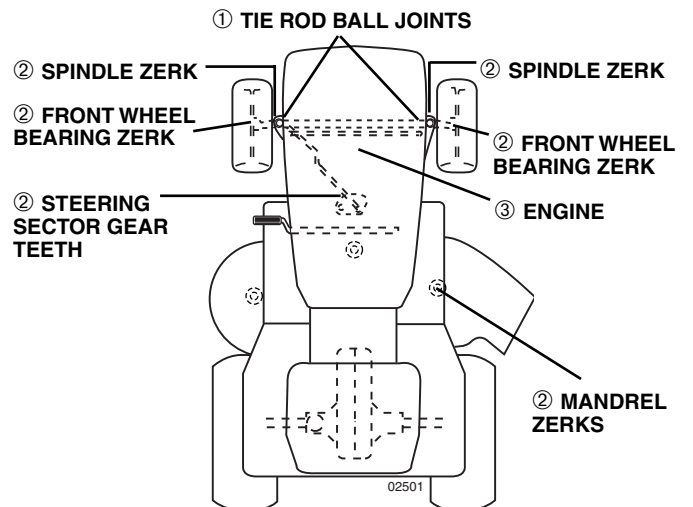

- SPRAY SILICONE LUBRICANT (MOVE BOOTS TO LUBRICATE)
- GENERAL PURPOSE GREASE
- REFER TO MAINTENANCE "ENGINE" SECTION

IMPORTANT: DO NOT OIL OR GREASE THE PIVOT POINTS WHICH HAVE SPECIAL NYLON BEARINGS. VISCOUS LUBRICANTS WILL ATTRACT DUST AND DIRT THAT WILL SHORTEN THE LIFE OF THE SELF-LUBRICATING BEARINGS. IF YOU FEEL THEY MUST BE LUBRICATED, USE ONLY A DRY, POWDERED GRAPHITE TYPE LUBRICANT SPARINGLY.

MAINTENANCE

TRACTOR

Always observe safety rules when performing any maintenance.

BRAKE OPERATION

If tractor requires more than six (6) feet stopping distance at high speed in highest gear, then brake must be adjusted. (See "TO ADJUST BRAKE" in the Service and Adjustments section of this manual).

TIRES

- Maintain proper air pressure in all tires (See "PRODUCT SPECIFICATIONS" section of this manual).
- Keep tires free of gasoline, oil, or insect control chemicals which can harm rubber.
- Avoid stumps, stones, deep ruts, sharp objects and other hazards that may cause tire damage.

NOTE: To seal tire punctures and prevent flat tires due to slow leaks, tire sealant may be purchased from your local parts dealer. Tire sealant also prevents tire dry rot and corrosion.

OPERATOR PRESENCE SYSTEM

Be sure operator presence and interlock systems are working properly. If your tractor does not function as described, repair the problem immediately.

- The engine should not start unless the brake pedal is fully depressed and attachment clutch control is in the disengaged position.
- When the engine is running, any attempt by the operator to leave the seat without first setting the parking brake should shut off the engine.
- When the engine is running and the attachment clutch is engaged, any attempt by the operator to leave the seat should shut off the engine.
- The attachment clutch should never operate unless the operator is in the seat..

BLADE CARE

For best results mower blades must be kept sharp. Replace bent or damaged blades.

BLADE REMOVAL (See Fig. 13)

- Raise mower to highest position to allow access to blades.

NOTE: Protect your hands with gloves and/or wrap blade with heavy cloth.

- Remove blade bolt by turning counterclockwise.
- Install new or resharpened blade with stamped "THIS SIDE UP" facing deck and mandrel assembly.

IMPORTANT: TO ENSURE PROPER ASSEMBLY, CENTER HOLE IN BLADE MUST ALIGN WITH STAR ON MANDREL ASSEMBLY.

- Install and tighten blade bolt securely (45-55 Ft. Lbs. torque).

IMPORTANT: SPECIAL BLADE BOLT HEAT TREATED.

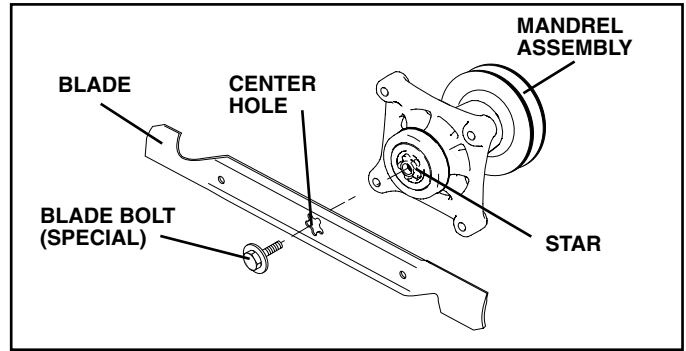

FIG. 13

TO SHARPEN BLADE (See Fig. 14)

NOTE: We do not recommend sharpening blade - but if you do, be sure the blade is balanced.

Care should be taken to keep the blade balanced. An unbalanced blade will cause excessive vibration and eventual damage to mower and engine.

- The blade can be sharpened with a file or on a grinding wheel. Do not attempt to sharpen while on the mower.
- To check blade balance, you will need a 5/8" diameter steel bolt, pin, or a cone balancer. (When using a cone balancer, follow the instructions supplied with balancer.)

NOTE: Do not use a nail for balancing blade. The lobes of the center hole may appear to be centered, but are not.

- Slide blade on to an unthreaded portion of the steel bolt or pin and hold the bolt or pin parallel with the ground. If blade is balanced, it should remain in a horizontal position. If either end of the blade moves downward, sharpen the heavy end until the blade is balanced.

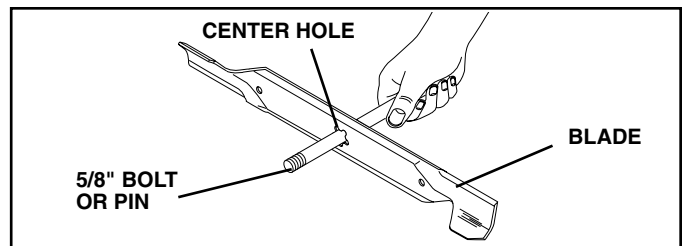

FIG. 14

BATTERY

Your tractor has a battery charging system which is sufficient for normal use. However, periodic charging of the battery with an automotive charger will extend its life.

- Keep battery and terminals clean.
- Keep battery bolts tight.
- Keep small vent holes open.
- Recharge at 6-10 amperes for 1 hour.

NOTE: The original equipment battery on your tractor is maintenance free. Do not attempt to open or remove caps or covers. Adding or checking level of electrolyte is not necessary.

MAINTENANCE

TO CLEAN BATTERY AND TERMINALS

Corrosion and dirt on the battery and terminals can cause the battery to “leak” power.

- Remove terminal guard.
- Disconnect BLACK battery cable first then RED battery cable and remove battery from tractor.
- Rinse the battery with plain water and dry.
- Clean terminals and battery cable ends with wire brush until bright.
- Coat terminals with grease or petroleum jelly.
- Reinstall battery (See “CONNECT BATTERY” in the Assembly section of this manual).

V-BELTS

Check V-belts for deterioration and wear after 100 hours of operation and replace if necessary. The belts are not adjustable. Replace belts if they begin to slip from wear.

TRANSAXLE COOLING

The transmission fan and cooling fins should be kept clean to assure proper cooling.

Do not attempt to clean fan or transmission while engine is running or while the transmission is hot. To prevent possible damage to seals, do not use high pressure water or steam to clean transaxle.

- Inspect cooling fan to be sure fan blades are intact and clean.
- Inspect cooling fins for dirt, grass clippings and other materials. To prevent damage to seals, do not use compressed air or high pressure sprayer to clean cooling fins.

TRANSAXLE PUMP FLUID

The transaxle was sealed at the factory and fluid maintenance is not required for the life of the transaxle. Should the transaxle ever leak or require servicing, contact your nearest authorized service center/department.

ENGINE

LUBRICATION

Only use high quality detergent oil rated with API service classification SF-SJ. Select the oil’s SAE viscosity grade according to your expected operating temperature.

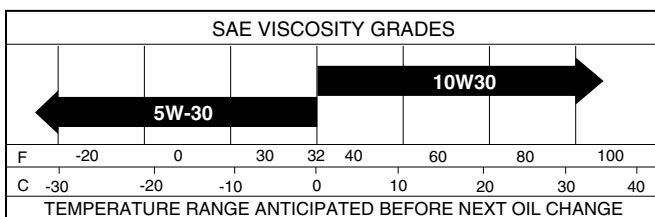

FIG. 15

Change the oil after every 50 hours of operation or at least once a year if the tractor is not used for 50 hours in one year.

Check the crankcase oil level before starting the engine and after each eight (8) hours of operation.

TO CHANGE ENGINE OIL (See Figs. 15 and 16)

Determine temperature range expected before oil change. All oil must meet API service classification SF-SJ.

- Be sure tractor is on level surface.
- Oil will drain more freely when warm.
- Catch oil in a suitable container.
- Remove oil fill cap/dipstick. Be careful not to allow dirt to enter the engine when changing oil.
- Remove yellow cap from end of drain valve and install the drain tube onto the fitting.

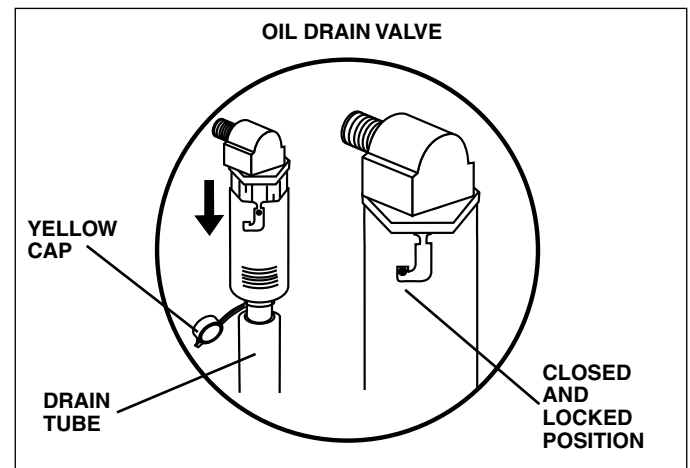

FIG. 16

- Unlock drain valve by pushing inward and turning counterclockwise.
- To open, pull out on the drain valve.
- After oil has drained completely, close and lock the drain valve by pushing inward and turning clockwise until the pin is in the locked position as shown.
- Remove the drain tube and replace the cap onto to the bottom fitting of the drain valve.
- Refill engine with oil through oil fill dipstick tube. Pour slowly. Do not overfill. For approximate capacity see “PRODUCT SPECIFICATIONS” section of this manual.
- Use gauge on oil fill cap/dipstick for checking level. Insert dipstick into the tube and rest the oil fill cap on the tube. Do not thread the cap onto the tube when taking reading. Keep oil at “FULL” line on dipstick. Tighten cap onto the tube securely when finished.

CLEAN AIR SCREEN

Air screen must be kept free of dirt and chaff to prevent engine damage from overheating. Clean with a wire brush or compressed air to remove dirt and stubborn dried gum fibers.

MAINTENANCE

CLEAN AIR INTAKE/COOLING AREAS

To insure proper cooling, make sure the grass screen, cooling fins, and other external surfaces of the engine are kept clean at all times.

Every 100 hours of operation (more often under extremely dusty, dirty conditions), remove the blower housing and other cooling shrouds. Clean the cooling fins and external surfaces as necessary. Make sure the cooling shrouds are reinstalled.

NOTE: Operating the engine with a blocked grass screen, dirty or plugged cooling fins, and/or cooling shrouds removed will cause engine damage due to overheating.

air, as this will damage the cartridge. Replace a dirty, bent, or damaged cartridge.

AIR FILTER (See Fig. 17)

Your engine will not run properly using a dirty air filter. Clean the foam pre-cleaner after every 25 hours of operation or every season. Service paper cartridge every 100 hours of operation or every season, whichever occurs first.

Service air cleaner more often under dusty conditions.

- Loosen knob and remove cover.

TO SERVICE PRE-CLEANER

- Slide foam pre-cleaner off cartridge.
- Wash it in liquid detergent and water.
- Squeeze it dry in a clean cloth. Allow it to dry.
- Saturate it in engine oil. Wrap it in clean, absorbent cloth and squeeze to remove excess oil.

TO SERVICE CARTRIDGE

- Replace a dirty, bent, or damaged cartridge.

NOTE: Do not wash the paper cartridge or use pressurized air, as this will damage the cartridge.

- Remove nut and cartridge plate.
- Reinstall the pre-cleaner (cleaned and oiled) over the paper cartridge.
- Check rubber seal for damage and proper position around stud. Replace if necessary.
- Reassemble air cleaner, cartridge plate, and nut.
- Reinstall air cleaner cover and secure by tightening knob.

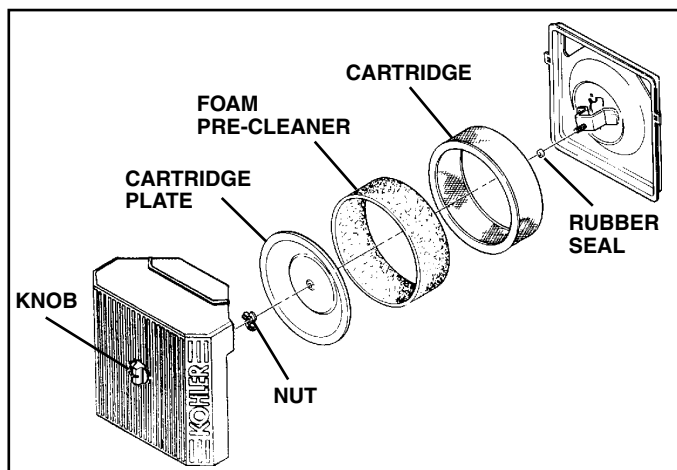

FIG. 17

ENGINE OIL FILTER

Replace the engine oil filter every season or every other oil change if the tractor is used more than 100 hours in one year.

MUFFLER

Inspect and replace corroded muffler and spark arrester (if equipped) as it could create a fire hazard and/or damage.

SPARK PLUGS

Replace spark plugs at the beginning of each mowing season or after every 100 hours of operation, whichever occurs first. Spark plug type and gap setting are shown in "PRODUCT SPECIFICATIONS" section of this manual.

IN-LINE FUEL FILTER (See Fig. 18)

The fuel filter should be replaced once each season. If fuel filter becomes clogged, obstructing fuel flow to carburetor, replacement is required.

- With engine cool, remove filter and plug fuel line sections.
- Place new fuel filter in position in fuel line with arrow pointing towards carburetor.
- Be sure there are no fuel line leaks and clamps are properly positioned.
- Immediately wipe up any spilled gasoline.

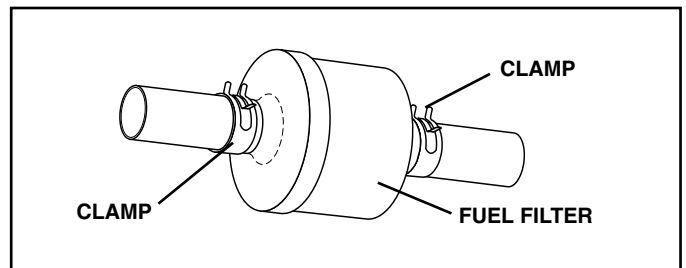

FIG. 18

CLEANING

- Clean engine, battery, seat, finish, etc. of all foreign matter.
- Keep finished surfaces and wheels free of all gasoline, oil, etc.
- Protect painted surfaces with automotive type wax.

We do not recommend using a garden hose or pressure washer to clean your tractor unless the engine and transmission are covered to keep water out. Water in engine or transmission will shorten the useful life of your tractor. Use compressed air or a leaf blower to remove grass, leaves and trash from tractor and mower.

SERVICE AND ADJUSTMENTS



WARNING: TO AVOID SERIOUS INJURY, BEFORE PERFORMING ANY SERVICE OR ADJUSTMENTS:

- Depress brake pedal fully and set parking brake.
- Place attachment clutch in “DISENGAGED” position.
- Turn ignition key to “STOP” and remove key.
- Make sure the blades and all moving parts have completely stopped.
- Disconnect spark plug wire from spark plug and place wire where it cannot come in contact with plug.

TRACTOR

TO REMOVE MOWER (See Fig. 19)

- Place attachment clutch in “DISENGAGED” position.
- If equipped, turn height adjustment knob to lowest setting.
- Lower mower to its lowest position.
- Disengage belt tension rod from lock bracket.



CAUTION: Rod is spring loaded. Have a tight grip on rod and release slowly.

- Remove retainer spring holding anti-swaybar to chassis bracket and disengage anti-swaybar from bracket.
- Remove four retainer springs from front plate assembly and remove plate.
- Remove retainer springs from suspension arms at deck and disengage arms from deck.
- Raise attachment lift to its highest position.
- Slide mower forward and remove belt from electric clutch pulley.
- Slide mower out from under right side of tractor.

TO INSTALL MOWER

Be sure tractor is on level surface and mower suspension arms are raised with attachment lift control. Engage parking brake.

- Swing anti-sway bar to left side of mower deck.
- Slide mower under tractor with deflector shield to right side of tractor.

IMPORTANT: CHECK BELT FOR PROPER ROUTING IN ALL MOWER PULLEY GROOVES.

- If equipped, turn height adjustment knob counter-clockwise until it stops.
- Lower mower linkage with attachment lift control.
- Be sure belt tension rod is in disengaged position.
- Install belt into electric clutch pulley groove.
- Place the suspension arms on outward pointing deck pins. Retain with double loop retainer spring with loops up as shown.
- Install front plate assembly to tractor suspension brackets and retain with single loop retainer springs as shown.
- Position front plate assembly between front mower brackets. Raise deck and plate assembly to align holes and insert flanged pins. Secure pins with double loop retainer springs between the plate assembly and mower brackets.

NOTE: To assist in locating hole in flanged pin, the hole in pin is inline with notch on head of pin. If necessary, move mower side-to-side to give space between plate and mower brackets.

IMPORTANT: CHECK BELT FOR PROPER ROUTING IN ALL MOWER PULLEY GROOVES.

- Engage belt tension rod by pushing rod into locking bracket.



CAUTION: Belt tension rod is spring loaded. Have a tight grip on rod and engage slowly.

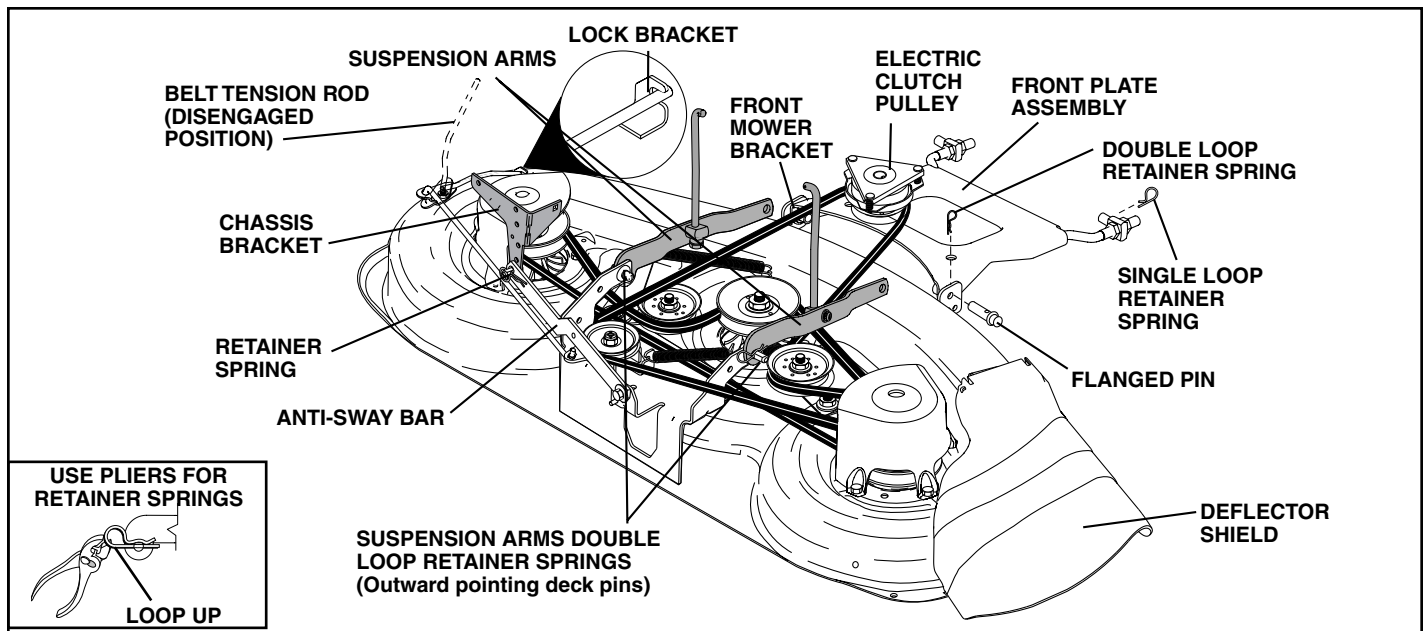

FIG. 19

SERVICE AND ADJUSTMENTS

- Connect anti-sway bar to chassis bracket under left footrest and retain with double loop retainer spring.
- If equipped, turn height adjustment knob clockwise to remove slack from mower suspension.
- Raise deck to highest position.

TO LEVEL MOWER HOUSING

Adjust the mower while tractor is parked on level ground such as a carport or garage. Make sure tires are properly inflated (See "PRODUCT SPECIFICATIONS" section of this manual). If tires are over or underinflated, you will not properly adjust your mower.

SIDE-TO-SIDE ADJUSTMENT WITH BUBBLE LEVEL (See Figs. 20 and 21)

NOTE: If necessary, check side-to-side surface below tractor for levelness with a long board and the bubble level.

- Using the lift lever, place mower in position where no part of the mower, including gauge wheels, is touching the ground.
- From left side of tractor, find the level decal on top of mower and place bubble level on decal as indicated.
- Mower is level side-to-side when bubble is between the two lines in the bubble level.
- If adjustment is necessary, under left hand footrest, turn lift link adjustment nut (above yellow cap) in appropriate direction to bring bubble between the lines in the bubble level.
- Remove bubble level from mower and store in a safe place.

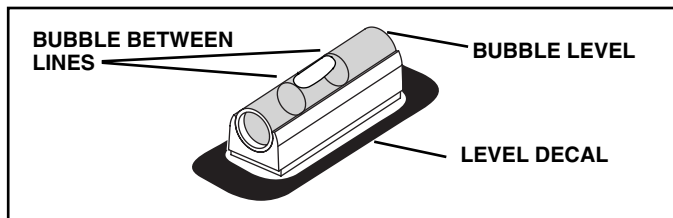

FIG. 20

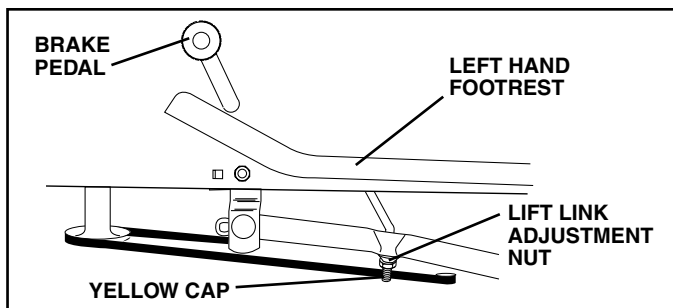

FIG. 21

ALTERNATE SIDE-TO-SIDE ADJUSTMENT METHOD (See Figs. 22 and 23)

- Raise mower to its highest position.
- Measure height from bottom edge of mower to ground level at front corners of mower. Distance "A" on both sides of mower should be the same.
- If adjustment is necessary, make adjustment on one side of mower only.
- To raise one side of mower, tighten lift link adjustment nut on that side.

- To lower one side of mower, loosen lift link adjustment nut on that side.

NOTE: Each full turn of adjustment nut will change mower height about 3/16".

- Recheck measurements after adjusting.

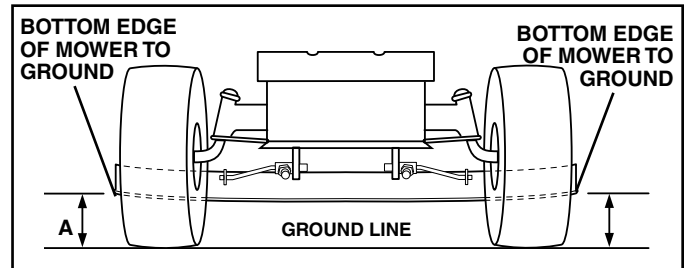

FIG. 22

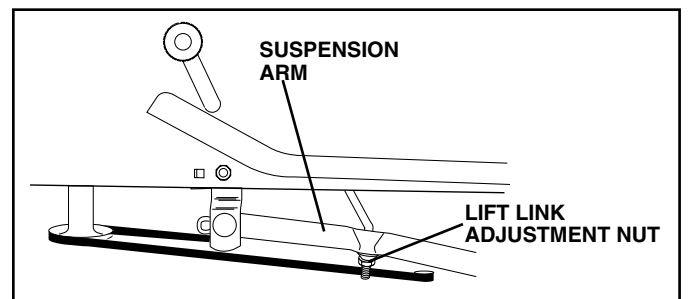
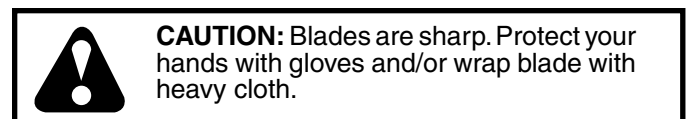

FIG. 23

FRONT-TO-BACK ADJUSTMENT (See Figs. 24 and 25)

IMPORTANT: Deck must be level side-to-side. If the following front-to-back adjustment is necessary, be sure to adjust both front links equally so mower will stay level side-to-side.

To obtain the best cutting results, the mower blades should be adjusted so the front tip is approximately 1/8" to 1/2" lower than the rear tip when the mower is in its highest position.



Check adjustment on right side of tractor. Position any blade so the tip is pointing straight forward. Measure distance "B" at front and rear tip of blade.

- Before making any necessary adjustments, check that both front plate links are equal in length.
- If links are not equal in length, adjust one link to same length as other link.
- To lower front of blade, loosen nut "C" on both front links an equal number of turns.

NOTE: Each full turn of nut "C" will change dim. "B" by approximately 3/16".

- When distance "B" is 1/8" to 1/2" lower at front than rear, tighten nut "D" against trunnion on both front links.
- To raise front of blade, loosen nut "D" from trunnion on both front links. Tighten nut "C" on both front links an equal number of turns. The two front links must remain equal in length.

SERVICE AND ADJUSTMENTS

- When distance "B" is 1/8" to 1/2" lower at front than rear, tighten nut "D" against trunnion on both front links.
- Recheck side-to-side adjustment.

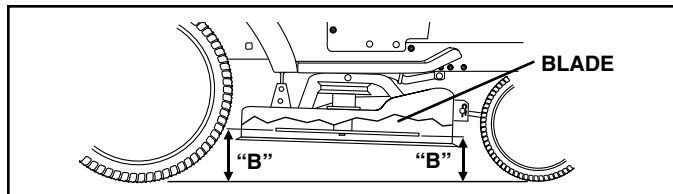

FIG. 24

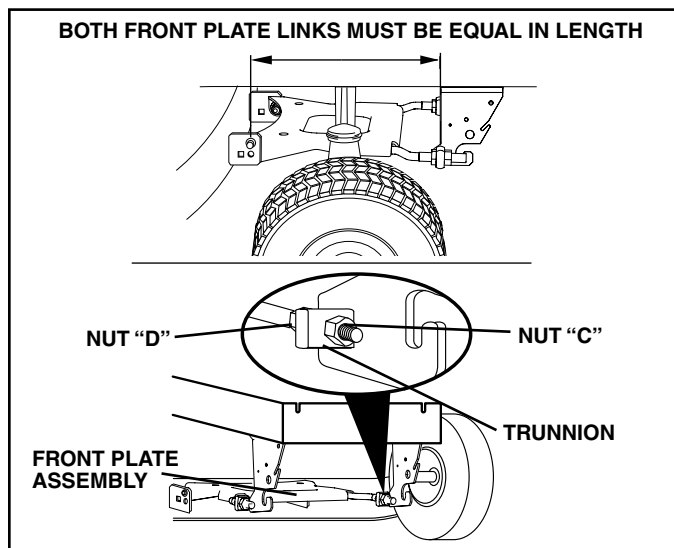

FIG. 25

TO REPLACE MOWER DRIVE BELT

MOWER DRIVE BELT REMOVAL (See Fig. 26)

- Park tractor on a level surface. Engage parking brake.
- Lower mower to its lowest position.
- Disengage belt tension rod from lock bracket.



CAUTION: Rod is spring loaded. Have a tight grip on rod and release slowly.

- Remove screws from R.H. mandrel cover and remove cover.
- Remove any dirt or grass clippings which may have accumulated around mandrels and entire upper deck surface.
- Disconnect R.H. suspension arm from rear deck bracket by removing retainer spring.
- Roll belt over the top of R.H. mandrel pulley carefully.
- Remove belt from electric clutch pulley.
- Remove belt from idler pulleys.
- Check primary idler arm and two idlers to see that they rotate freely.
- Be sure spring is securely hooked to primary idler arm and spring arm.

MOWER DRIVE BELT INSTALLATION (See Fig. 25)

- Install belt in both idlers.
- Install new belt onto electric clutch pulley.

- Roll belt into upper groove of R.H. mandrel pulley carefully.
- Carefully check belt routing making sure belt is in the grooves correctly.
- Reconnect R.H. suspension arm to rear deck bracket with retainer spring.
- Reassemble R.H. mandrel cover.
- Engage belt tension rod by pushing rod into locking bracket.

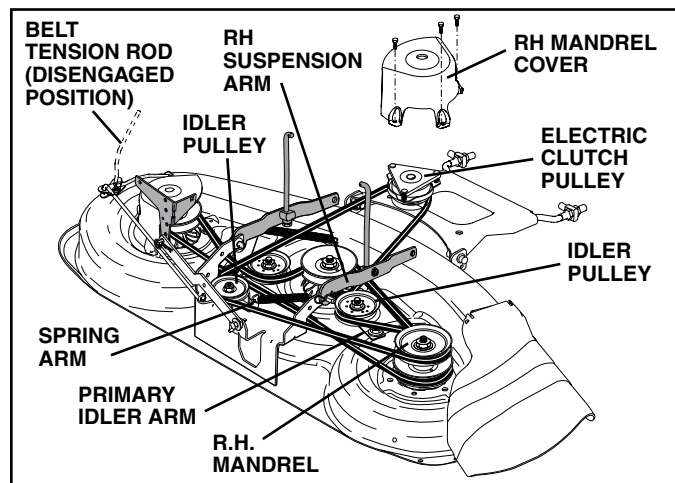

FIG. 26

TO REPLACE MOWER BLADE (SECONDARY) DRIVE BELT (See Fig. 27)

Park the tractor on level surface. Engage parking brake.

- Remove mower (See "TO REMOVE MOWER" in this section of manual).
- Remove screws from R.H. and L.H. mandrel covers and remove covers.

REMOVE MOWER DRIVE BELT

(Refer to "TO REMOVE MOWER DRIVE BELT" illustration in this section of manual).

- Carefully roll belt over the top of R.H. mandrel pulley.
- Remove belt from idler pulleys.
- Check primary idler arm and two idlers to see that they rotate freely.
- Be sure spring is securely hooked to primary idler arm and spring arm.

REMOVE MOWER BLADE (SECONDARY) DRIVE BELT

- Carefully roll belt off L.H. mandrel pulley.
- Remove belt from center mandrel pulley, idler pulley, and R.H. mandrel pulley.
- Remove any dirt or grass which may have accumulated around mandrels and entire upper deck surface.
- Check secondary idler arm and idler pulley to see that they rotate freely.
- Be sure spring is hooked in secondary idler arm and secondary spring arm.

INSTALL NEW MOWER BLADE (SECONDARY) DRIVE BELT

- Install new belt in lower groove of R.H. mandrel pulley, idler pulley, and center mandrel pulley as shown.
- Carefully roll belt over L.H. mandrel pulley. Make sure belt is in all grooves properly.

SERVICE AND ADJUSTMENTS

REINSTALL MOWER DRIVE BELT

(Refer to "TO REMOVE MOWER DRIVE BELT" illustration in this section of manual).

- Install belt into upper groove of R.H. mandrel pulley and around both idlers. Pull belt to front of mower to remove slack.
- Reinstall mandrel covers and securely tighten all screws.
- Carefully check belt routing making sure belt is in all grooves correctly.
- Reinstall mower to tractor (See "TO INSTALL MOWER" in this section of manual).

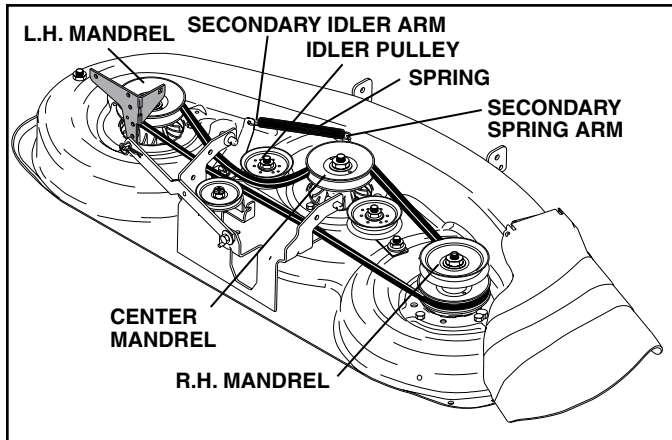

FIG. 27

TO ADJUST ATTACHMENT CLUTCH (See Fig. 28)

The electric clutch should provide years of service. The clutch has a built-in brake that stops the pulley within 5 seconds. Eventually, the internal brake will wear which may cause the mower blades to not engage, or, to not stop as required. Adjustments should be made by your nearest authorized service center/department.

- Make sure attachment clutch and ignition switches are in "OFF" position.
- Adjust the three nylon locknuts until space between clutch plate and rotor measures .012" at all three slot locations cut in side of brake plate.

NOTE: After installing a new electric clutch, run tractor at full throttle and engage and disengage electric clutch 10 cycles to wear in clutch plate.

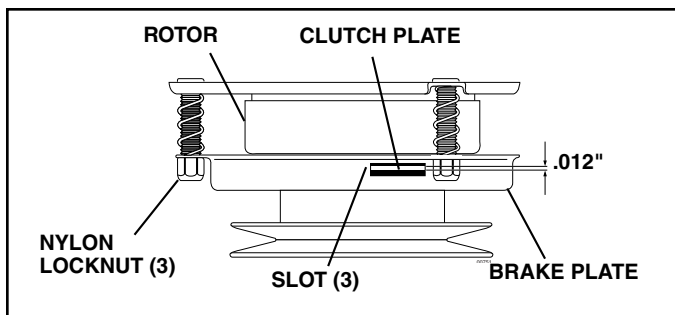

FIG. 28

TO CHECK AND ADJUST BRAKE

If tractor requires more than five (5) feet to stop at highest speed in highest gear on a level, dry concrete or paved surface, then brake must be checked and adjusted.

TO CHECK BRAKE

- Park tractor on a level, dry concrete or paved surface, depress clutch/brake pedal all the way down and engage parking brake.
- Disengage transmission by placing freewheel control in "transmission disengaged" position. Pull freewheel control out and into the slot and release so it is held in the disengaged position.

The rear wheels must lock and skid when you try to manually push the tractor forward. If the rear wheels rotate, the brake needs to be adjusted or the pads need to be replaced.

TO ADJUST BRAKE/REPLACE PADS

Contact a qualified service center.

TO REPLACE MOTION DRIVE BELT (See Fig. 29)

Park the tractor on level surface. Engage parking brake. For ease of service there is a belt installation guide decal on bottom of left footrest.

- Remove mower (See "TO REMOVE MOWER" in this section of this manual.)

BELT REMOVAL -

- Create slack in belt by removing retainer spring from drive belt tension handle.
- Remove belt from all idler pulleys, transaxle pulley and then from engine pulley.

BELT INSTALLATION -

- Install new belt around engine pulley first, then around transaxle pulley and lastly into all the idler pulleys.
- Check to be sure belt is positioned correctly and is on proper side of all belt keepers.
- Engage the drive belt tension handle and replace the retainer spring.
- Reinstall mower.

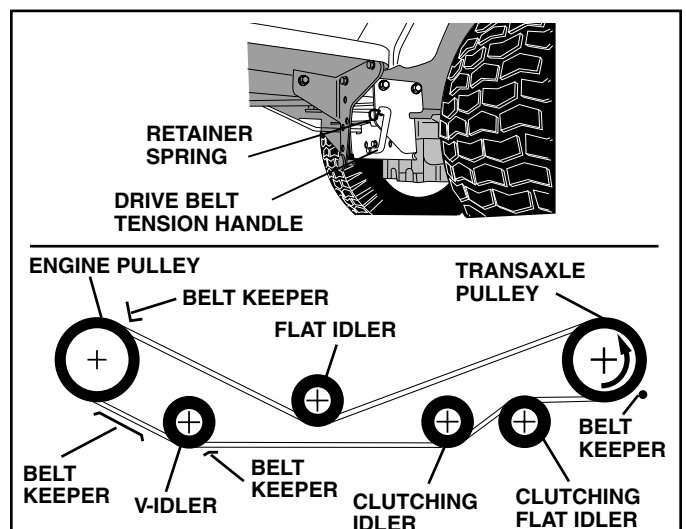

FIG. 29

SERVICE AND ADJUSTMENTS

TRANSAXLE MOTION CONTROL LEVER NEUTRAL ADJUSTMENT (See Fig. 30)

The motion control lever has been preset at the factory and adjustment should not be necessary.

- Park tractor on level surface. Stop tractor by turning ignition key to "OFF" position and engage parking brake.
- Loosen the adjustment bolt in front of the right rear wheel.
- Move motion control lever to the neutral position (N).
- Tighten the adjustment bolt.

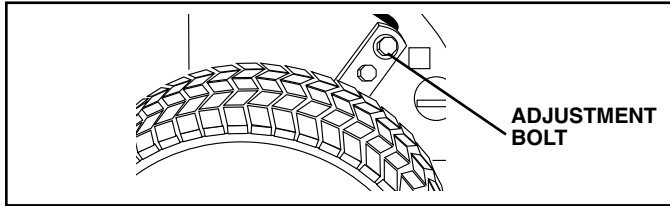

FIG. 30

TRANSMISSION REMOVAL/REPLACEMENT

Should your transmission require removal for service or replacement, it should be purged after reinstallation before operating the tractor. See "PURGE TRANSMISSION" in Operation section of this manual.

TO ADJUST STEERING WHEEL ALIGNMENT

If steering wheel crossbars are not horizontal (left to right) when wheels are positioned straight forward, remove steering wheel and reassemble per instructions in the Assembly section of this manual.

FRONT WHEEL TOE-IN/CAMBER

The front wheel toe-in and camber are not adjustable on your tractor. If damage has occurred to affect the front wheel toe-in or camber, contact your nearest authorized service center/department.

TO REMOVE WHEEL FOR REPAIRS

FRONT WHEEL (See Fig. 31)

- Block up axle securely.
- Remove axle cover, retaining ring and washers to allow wheel removal.
- Repair tire and reassemble.
- Replace washers and snap retaining ring securely in axle groove.
- Replace axle cover.

REAR WHEEL -

- Block rear axle securely.
- Remove five (5) hub bolts to allow wheel removal.
- Repair tire and reassemble. Replace and tighten hub bolts securely.

NOTE: To seal tire punctures and prevent flat tires due to slow leaks, tire sealant may be purchased from your local parts dealer. Tire sealant also prevents tire dry rot and corrosion.

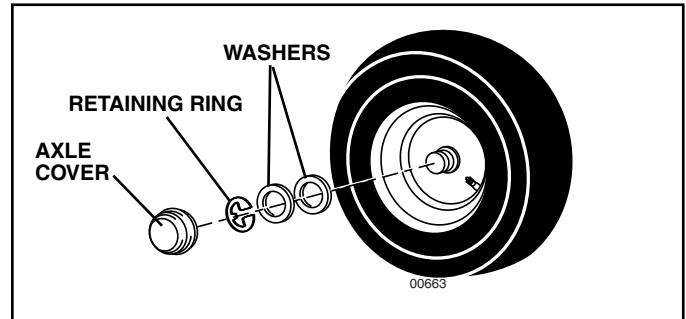

FIG. 31

TO START ENGINE WITH A WEAK BATTERY (See Fig. 32)



WARNING: Lead-acid batteries generate explosive gases. Keep sparks, flame and smoking materials away from batteries. Always wear eye protection when around batteries.

If your battery is too weak to start the engine, it should be recharged. (See "BATTERY" in the Maintenance section of this manual).

If "jumper cables" are used for emergency starting, follow this procedure:

IMPORTANT: YOUR TRACTOR IS EQUIPPED WITH A 12 VOLT SYSTEM. THE OTHER VEHICLE MUST ALSO BE A 12 VOLT SYSTEM. DO NOT USE YOUR TRACTOR BATTERY TO START OTHER VEHICLES.

TO ATTACH JUMPER CABLES -

- Connect one end of the RED cable to the POSITIVE (+) terminal of each battery (A-B), taking care not to short against tractor chassis.
- Connect one end of the BLACK cable to the NEGATIVE (-) terminal (C) of fully charged battery.
- Connect the other end of the BLACK cable (D) to good chassis ground, away from fuel tank and battery.

TO REMOVE CABLES, REVERSE ORDER -

- BLACK cable first from chassis and then from the fully charged battery.
- RED cable last from both batteries.

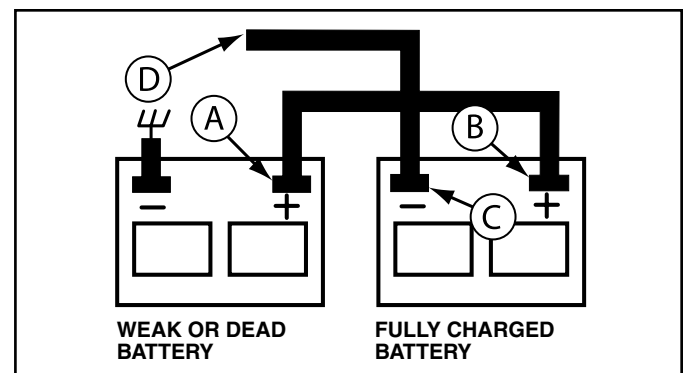

FIG. 32

SERVICE AND ADJUSTMENTS

TO REPLACE HEADLIGHT BULB

- Raise hood.
- Pull bulb holder out of the hole in the backside of the grill.
- Replace bulb in holder and push bulb holder securely back into the hole in the backside of the grill.
- Close hood.

INTERLOCKS AND RELAYS

Loose or damaged wiring may cause your tractor to run poorly, stop running, or prevent it from starting.

- Check wiring. See electrical wiring diagram in the Repair Parts section of this manual.

TO REPLACE FUSE

Replace with 30 amp automotive-type plug-in fuse. The fuse holder is located behind the dash.

TO REMOVE HOOD AND GRILL ASSEMBLY (See Fig. 33)

- Raise hood.
- Unsnap headlight wire connector.
- Stand in front of tractor. Grasp hood at sides, tilt toward engine and lift off of tractor.
- To replace, reverse above procedure.

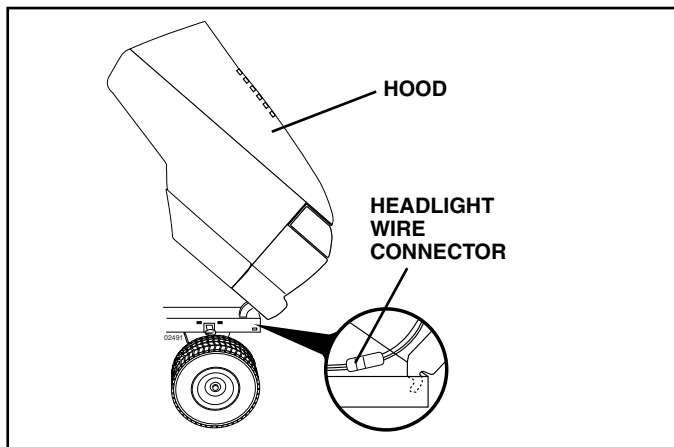

FIG. 33

ENGINE

Maintenance, repair, or replacement of the emission control devices and systems, which are being done at the customer's expense, may be performed by any non-road engine repair establishment or individual. Warranty repairs must be performed by an authorized engine manufacturer's service outlet.

TO ADJUST THROTTLE CONTROL CABLE (See Fig. 34)

The throttle control has been preset at the factory and adjustment should not be necessary. Check adjustment as described below before loosening cable. If adjustment is necessary, proceed as follows:

- With engine not running, move throttle control lever to fast position.
- Check that speed control lever is against stop screw. If it is not, loosen casing clamp screw and pull throttle cable until lever is against screw. Tighten clamp screw securely.

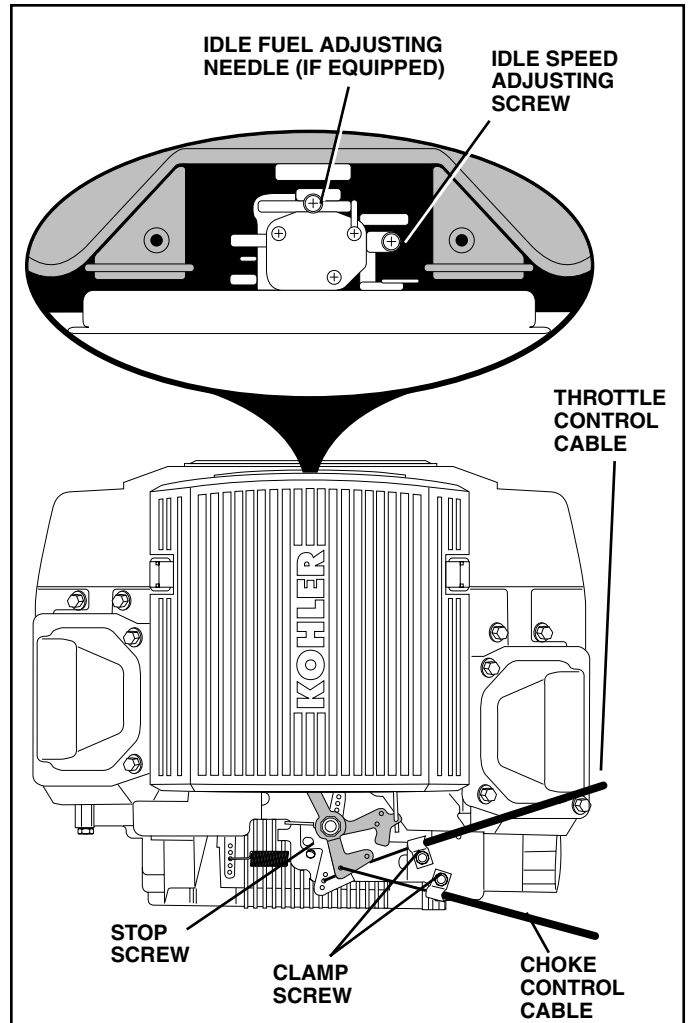

FIG. 34

SERVICE AND ADJUSTMENTS

TO ADJUST CHOKE CONTROL (See Figs. 34 and 35)

The choke control has been preset at the factory and adjustment should not be necessary. Check adjustment as described below before loosening cable. If adjustment is necessary, proceed as follows:

- With engine not running, move choke control (located on dash panel) to full choke position.
- Remove air cleaner cover, filter and cartridge plate to expose carburetor choke (See "AIR FILTER" in the Maintenance section of this manual).
- Choke should be closed. If it is not, loosen casing clamp screw and move choke cable until choke is completely closed. Tighten casing clamp screw securely.
- Reassemble air cleaner.

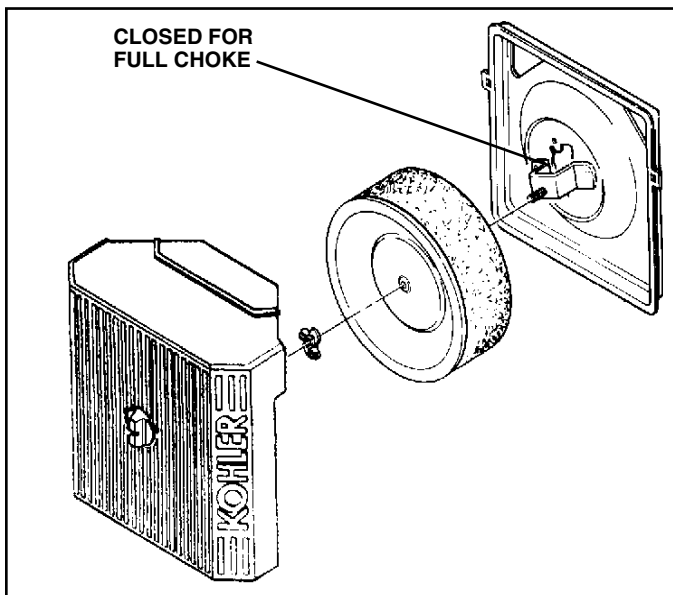

FIG. 35

TO ADJUST CARBURETOR (See Fig. 35)

The carburetor has been present at the factory and adjustment should not be necessary. However, minor adjustment may be required to compensate for differences in fuel, temperature, altitude or load. If the carburetor does need adjustment, proceed as follows:

In general, turning the adjusting needles **in** (clockwise) decreases the supply of fuel to the engine giving a leaner fuel/air mixture. Turning the adjusting needles **out** (counterclockwise) increases the supply of fuel to the engine giving a richer fuel/air mixture.

IMPORTANT: DAMAGE TO THE NEEDLES AND THE SEATS IN CARBURETOR MAY RESULT IF SCREW IS TURNED IN TOO TIGHT.

PRELIMINARY SETTING -

- Be sure you have a clean air filter, and the throttle control cable is adjusted properly (see "TO ADJUST THROTTLE CONTROL CABLE" in the Service and Adjustments section of this manual).
- With engine off turn idle fuel adjusting needle **in** (clockwise) closing it finger tight and then turn **out** (counterclockwise) 1 turn.

FINAL SETTING -

- Start engine and allow to warm for five minutes. Make final adjustments with engine running and shift/motion control lever in neutral (N) position.
- The high idle is set at the factory and cannot be adjusted.
- Idle speed setting - With throttle control lever in slow position, engine should idle at 1750 RPM. If engine idles too slow or fast, turn idle speed adjusting screw in or out until correct idle is attained.
- Idle fuel needle setting - With throttle control lever in slow position, turn idle fuel adjusting needle **in** (clockwise) until engine speed decreases and then turn **out** (counterclockwise) approximately 3/4 turn to obtain the best low speed performance.
- Recheck idle speed. Readjust if necessary.

ACCELERATION TEST -

- Move throttle control lever from slow to fast position. If engine hesitates or dies, turn idle fuel adjusting needle **out** (counterclockwise) 1/8 turn. Repeat test and continue to adjust, if necessary, until engine accelerates smoothly.

High speed stop is factory adjusted. Do not adjust-damage may result.

IMPORTANT: NEVER TAMPER WITH THE ENGINE GOVERNOR, WHICH IS FACTORY SET FOR PROPER ENGINE SPEED. OVERSPEEDING THE ENGINE ABOVE THE FACTORY HIGH SPEED SETTING CAN BE DANGEROUS. IF YOU THINK THE ENGINE-GOVERNED HIGH SPEED NEEDS ADJUSTING, CONTACT YOUR NEAREST AUTHORIZED SERVICE CENTER/DEPARTMENT, WHICH HAS PROPER EQUIPMENT AND EXPERIENCE TO MAKE ANY NECESSARY ADJUSTMENTS.

STORAGE

Immediately prepare your tractor for storage at the end of the season or if the tractor will not be used for 30 days or more.



WARNING: Never store the tractor with gasoline in the tank inside a building where fumes may reach an open flame or spark. Allow the engine to cool before storing in any enclosure.

TRACTOR

Remove mower from tractor for winter storage. When mower is to be stored for a period of time, clean it thoroughly, remove all dirt, grease, leaves, etc. Store in a clean, dry area.

- Clean entire tractor (See “CLEANING” in the Maintenance section of this manual).
- Inspect and replace belts, if necessary (See belt replacement instructions in the Service and Adjustments section of this manual).
- Lubricate as shown in the Maintenance section of this manual.
- Be sure that all nuts, bolts and screws are securely fastened. Inspect moving parts for damage, breakage and wear. Replace if necessary.
- Touch up all rusted or chipped paint surfaces; sand lightly before painting.

BATTERY

- Fully charge the battery for storage.
- After a period of time in storage, battery may require recharging.
- To help prevent corrosion and power leakage during long periods of storage, battery cables should be disconnected and battery cleaned thoroughly (see “TO CLEAN BATTERY AND TERMINALS” in the Maintenance section of this manual).
- After cleaning, leave cables disconnected and place cables where they cannot come in contact with battery terminals.
- If battery is removed from tractor for storage, do not store battery directly on concrete or damp surfaces.

ENGINE

FUEL SYSTEM

IMPORTANT: IT IS IMPORTANT TO PREVENT GUM DEPOSITS FROM FORMING IN ESSENTIAL FUEL SYSTEM PARTS SUCH AS CARBURETOR, FUEL FILTER, FUEL HOSE, OR TANK DURING STORAGE. ALSO, EXPERIENCE INDICATES THAT ALCOHOL BLENDED FUELS (CALLED GASOHOL OR USING ETHANOL OR METHANOL) CAN ATTRACT MOISTURE WHICH LEADS TO SEPARATION AND FORMATION OF ACIDS DURING STORAGE. ACIDIC GAS CAN DAMAGE THE FUEL SYSTEM OF AN ENGINE WHILE IN STORAGE.

- Drain the fuel tank.
- Start the engine and let it run until the fuel lines and carburetor are empty.
- Never use engine or carburetor cleaner products in the fuel tank or permanent damage may occur.
- Use fresh fuel next season.

NOTE: Fuel stabilizer is an acceptable alternative in minimizing the formation of fuel gum deposits during storage. Add stabilizer to gasoline in fuel tank or storage container. Always follow the mix ratio found on stabilizer container. Run engine at least 10 minutes after adding stabilizer to allow the stabilizer to reach the carburetor. Do not drain the gas tank and carburetor if using fuel stabilizer.

ENGINE OIL

Drain oil (with engine warm) and replace with clean engine oil. (See “ENGINE” in the Maintenance section of this manual).

CYLINDER(S)

- Remove spark plug(s).
- Pour one ounce of oil through spark plug hole(s) into cylinder(s).
- Turn ignition key to “START” position for a few seconds to distribute oil.
- Replace with new spark plug(s).

OTHER

- Do not store gasoline from one season to another.
- Replace your gasoline can if your can starts to rust. Rust and/or dirt in your gasoline will cause problems.
- If possible, store your tractor indoors and cover it to give protection from dust and dirt.
- Cover your tractor with a suitable protective cover that does not retain moisture. Do not use plastic. Plastic cannot breathe which allows condensation to form and will cause your tractor to rust.

IMPORTANT: NEVER COVER TRACTOR WHILE ENGINE AND EXHAUST AREAS ARE STILL WARM.

TROUBLESHOOTING POINTS

PROBLEM	CAUSE	CORRECTION
Will not start	<ol style="list-style-type: none"> 1. Out of fuel. 2. Engine not "CHOKED" properly. 3. Engine flooded. 4. Bad spark plug. 5. Dirty air filter. 6. Dirty fuel filter. 7. Water in fuel. 8. Loose or damaged wiring. 9. Carburetor out of adjustment. 10. Engine valves out of adjustment. 11. Extreme cold conditions. 	<ol style="list-style-type: none"> 1. Fill fuel tank. 2. See "TO START ENGINE" in Operation section. 3. Wait several minutes before attempting to start. 4. Replace spark plug. 5. Clean/replace air filter. 6. Replace fuel filter. 7. Drain fuel tank and carburetor, refill tank with fresh gasoline and replace fuel filter. 8. Check all wiring. 9. See "To Adjust Carburetor" in Service Adjustments section. 10. Contact an authorized service center/department. 11. See "To start engine" in operation section
Hard to start	<ol style="list-style-type: none"> 1. Dirty air filter. 2. Bad spark plug. 3. Weak or dead battery. 4. Dirty fuel filter. 5. Stale or dirty fuel. 6. Loose or damaged wiring. 7. Carburetor out of adjustment. 8. Engine valves out of adjustment. 	<ol style="list-style-type: none"> 1. Clean/replace air filter. 2. Replace spark plug. 3. Recharge or replace battery. 4. Replace fuel filter. 5. Drain fuel tank and refill with fresh gasoline. 6. Check all wiring. 7. See "To Adjust Carburetor" in Service Adjustments section. 8. Contact an authorized service center/department.
Engine will not turn over	<ol style="list-style-type: none"> 1. Brake pedal not depressed. 2. Attachment clutch is engaged. 3. Weak or dead battery. 4. Blown fuse. 5. Corroded battery terminals. 6. Loose or damaged wiring. 7. Faulty ignition switch. 8. Faulty solenoid or starter. 9. Faulty operator presence switch(es). 	<ol style="list-style-type: none"> 1. Depress brake pedal. 2. Disengage attachment clutch. 3. Recharge or replace battery. 4. Replace fuse. 5. Clean battery terminals. 6. Check all wiring. 7. Check/replace ignition switch. 8. Check/replace solenoid or starter. 9. Contact an authorized service center/department.
Engine clicks but will not start	<ol style="list-style-type: none"> 1. Weak or dead battery. 2. Corroded battery terminals. 3. Loose or damaged wiring. 4. Faulty solenoid or starter. 	<ol style="list-style-type: none"> 1. Recharge or replace battery. 2. Clean battery terminals. 3. Check all wiring. 4. Check/replace solenoid or starter.
Loss of power	<ol style="list-style-type: none"> 1. Cutting too much grass/too fast. 2. Throttle in "CHOKE" position. 3. Build-up of grass, leaves and trash under mower. 4. Dirty air filter. 5. Low oil level/dirty oil. 6. Faulty spark plug. 7. Dirty fuel filter. 8. Stale or dirty fuel. 9. Water in fuel. 10. Spark plug wire loose. 11. Dirty engine air screen/fins. 12. Dirty/clogged muffler. 13. Loose or damaged wiring. 14. Carburetor out of adjustment. 15. Engine valves out of adjustment. 	<ol style="list-style-type: none"> 1. Set in "Higher Cut" position/reduce speed. 2. Adjust throttle control. 3. Clean underside of mower housing. 4. Clean/replace air filter. 5. Check oil level/change oil. 6. Clean and regap or change spark plug. 7. Replace fuel filter. 8. Drain fuel tank and refill with fresh gasoline. 9. Drain fuel tank and carburetor, refill tank with fresh gasoline and replace fuel filter. 10. Connect and tighten spark plug wire. 11. Clean engine air screen/fins. 12. Clean/replace muffler. 13. Check all wiring. 14. See "To Adjust Carburetor" in Service Adjustments section. 15. Contact an authorized service center/department.
Excessive vibration	<ol style="list-style-type: none"> 1. Worn, bent or loose blade. 2. Bent blade mandrel. 3. Loose/damaged part(s). 	<ol style="list-style-type: none"> 1. Replace blade. Tighten blade bolt. 2. Replace blade mandrel. 3. Tighten loose part(s). Replace damaged parts.

TROUBLESHOOTING POINTS

PROBLEM	CAUSE	CORRECTION
Engine continues to run when operator leaves seat with attachment clutch engaged	<ol style="list-style-type: none"> 1. Faulty operator-safety presence control system. 	<ol style="list-style-type: none"> 1. Check wiring, switches and connections. If not corrected, contact an authorized service center/department.
Poor cut - uneven	<ol style="list-style-type: none"> 1. Worn, bent or loose blade. 2. Mower deck not level. 3. Buildup of grass, leaves, and trash under mower. 4. Bent blade mandrel. 5. Clogged mower deck vent holes from buildup of grass, leaves, and trash around mandrels. 	<ol style="list-style-type: none"> 1. Replace blade. Tighten blade bolt. 2. Level mower deck. 3. Clean underside of mower housing. 4. Replace blade mandrel. 5. Clean around mandrels to open vent holes.
Mower blades will not rotate	<ol style="list-style-type: none"> 1. Obstruction in clutch mechanism. 2. Worn/damaged mower drive belt. 3. Frozen idler pulley. 4. Frozen blade mandrel. 	<ol style="list-style-type: none"> 1. Remove obstruction. 2. Replace mower drive belt. 3. Replace idler pulley. 4. Replace blade mandrel.
Poor grass discharge	<ol style="list-style-type: none"> 1. Engine speed too slow. 2. Travel speed too fast. 3. Wet grass. 4. Mower deck not level. 5. Low/uneven tire air pressure. 6. Worn, bent or loose blade. 7. Buildup of grass, leaves and trash under mower. 8. Mower drive belt worn. 9. Blades improperly installed. 10. Improper blades used. 11. Clogged mower deck vent holes from buildup of grass, leaves, and trash around mandrels. 	<ol style="list-style-type: none"> 1. Place throttle control in "FAST" position. 2. Shift to slower speed. 3. Allow grass to dry before mowing. 4. Level mower deck. 5. Check tires for proper air pressure. 6. Replace/sharpen blade. Tighten blade bolt. 7. Clean underside of mower housing. 8. Replace mower drive belt. 9. Reinstall blades sharp edge down. 10. Replace with blades listed in this manual. 11. Clean around mandrels to open vent holes.
Headlight(s) not working (if so equipped)	<ol style="list-style-type: none"> 1. Switch is "OFF". 2. Bulb(s) or lamp(s) burned out. 3. Faulty light switch. 4. Loose or damaged wiring. 5. Blown fuse. 	<ol style="list-style-type: none"> 1. Turn switch "ON". 2. Replace bulb(s) or lamp(s). 3. Check/replace light switch. 4. Check wiring and connections. 5. Replace fuse.
Battery will not charge	<ol style="list-style-type: none"> 1. Bad battery cell(s). 2. Poor cable connections. 3. Faulty regulator (if so equipped). 4. Faulty alternator. 	<ol style="list-style-type: none"> 1. Replace battery. 2. Check/clean all connections. 3. Replace regulator. 4. Replace alternator.
Loss of drive	<ol style="list-style-type: none"> 1. Freewheel control in "disengaged" position. 2. Motion drive belt worn, damaged, or broken. 3. Air trapped in transmission during shipment or servicing. 	<ol style="list-style-type: none"> 1. Place freewheel control in "engaged" position. 2. Replace motion drive belt. 3. Purge transmission.
Engine "backfires" when turning engine "OFF"	<ol style="list-style-type: none"> 1. Engine throttle control not set at "SLOW" position for 30 seconds before stopping engine. 	<ol style="list-style-type: none"> 1. Move throttle control to "SLOW" position and allow to idle for 30 seconds before stopping engine.

TRACTOR - - MODEL NUMBER 944.603900

SCHEMATIC

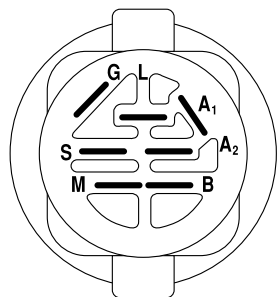
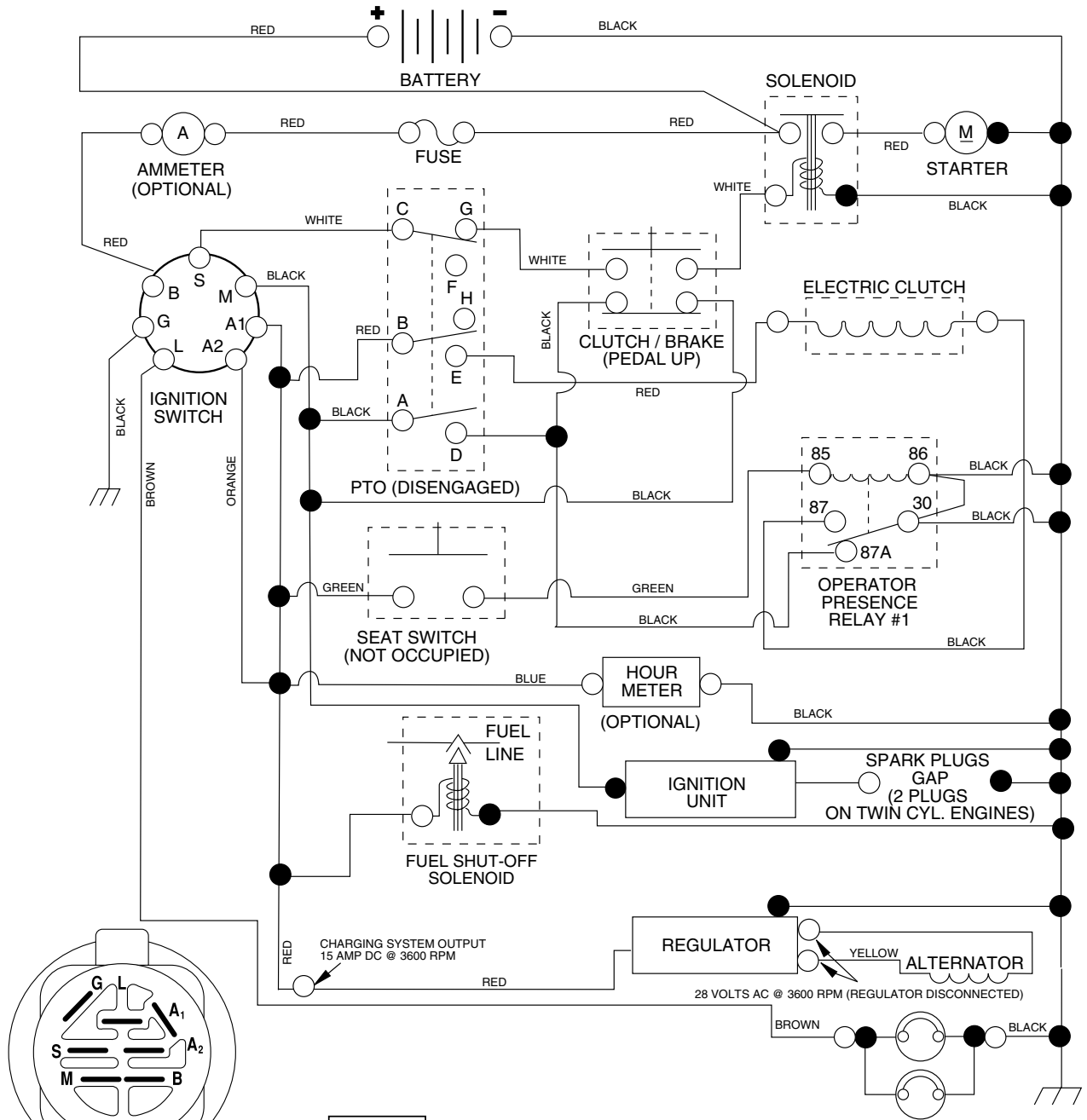

IGNITION SWITCH

POSITION	CIRCUIT	"MAKE"
OFF	M + G + A1	NONE
ON + LIGHTS	B + A1	L + A2
ON	B + A1	NONE
START	B + S + A1	NONE

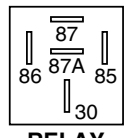

RELAY

PTO SWITCH	
POSITION	CIRCUIT
OFF	C + G, B + H
ON	C + F, B + E, A + D



REMOVABLE CONNECTIONS



NON-REMOVABLE CONNECTIONS

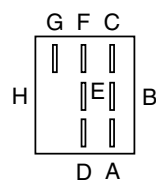

D A

WIRING INSULATED CLIPS
NOTE: IF WIRING INSULATED CLIPS WERE REMOVED FOR SERVICING OF UNIT, THEY SHOULD BE REPLACED TO PROPERLY SECURE YOUR WIRING.

REPAIR PARTS

TRACTOR - - MODEL NUMBER 944.603900

ELECTRICAL

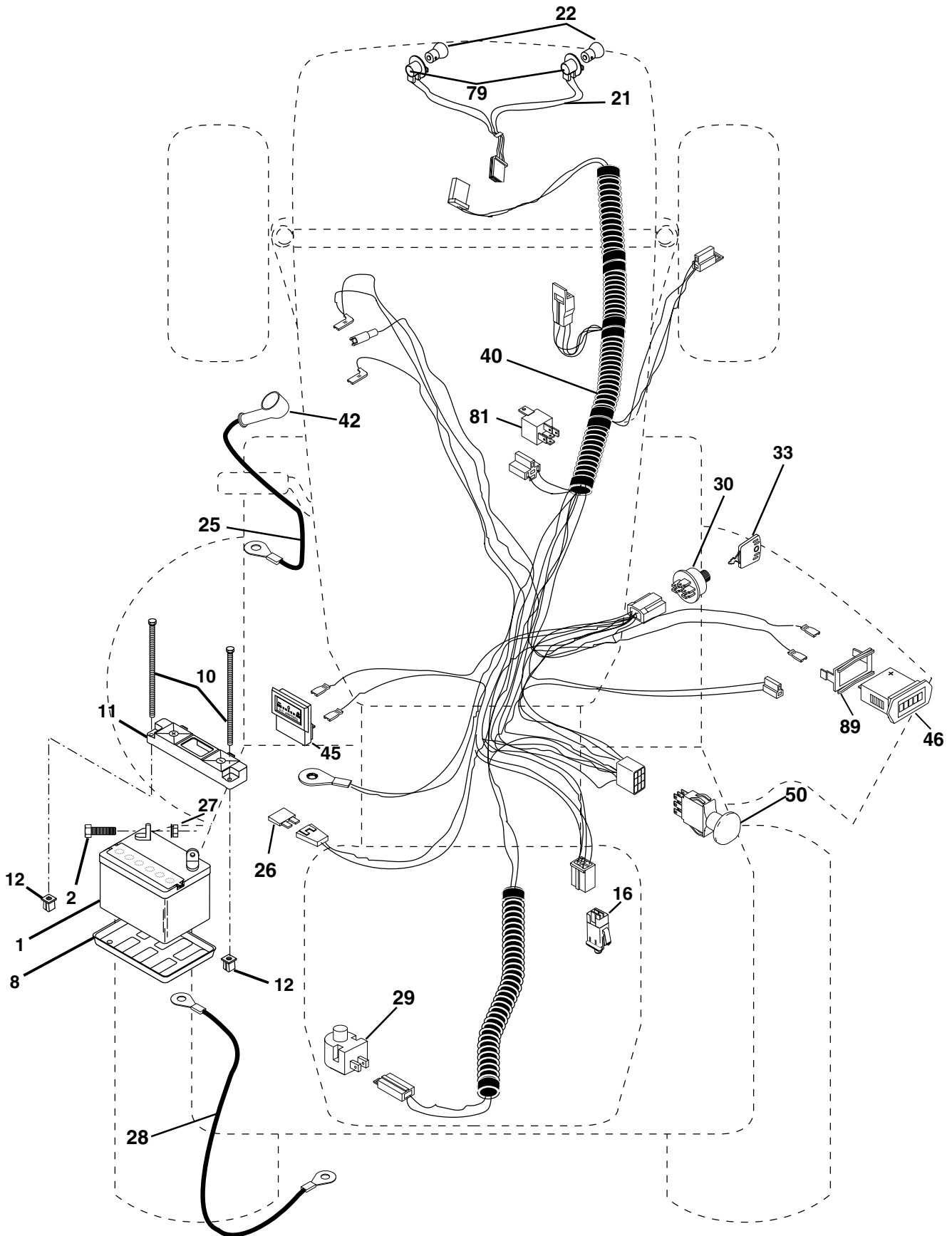

REPAIR PARTS

TRACTOR - - MODEL NUMBER 944.603900

ELECTRICAL

KEY NO.	PART NO.	DESCRIPTION
1	144927	Battery
2	74760412	Bolt Hex Head 1/4-20 x 3/4
8	7603J	Tray, Battery
10	145211	Bolt Btr Frt 1/4-20 x 7.5 zinc
11	150109	Holdown Battery Front Mount
12	145769	Nut Push Nylon 1/4"
16	176138	Switch Interlock Push-In
21	175688	Harness Headlight
22	4152J	Bulb Light
25	185456	Cable, Battery
26	108824X	Fuse
27	73510400	Nut Keps Hex 1/4-20 Unc
28	170697	Cable, Ground
29	160784	Switch, Plunger
30	175566	Switch, Ign
33	140403	Key
40	170238	Harness, Ignition
42	131563	Cover, Terminal Red
45	122822X	Ammeter
46	169635	Hourmeter Snap-In
50	174652	Switch, PTO
79	175242	Socket, Light Bulb
81	109748X	Relay Asm
89	169639	Bracket Snap-In Hourmeter

NOTE: All component dimensions given in U.S.
inches 1 inch = 25.4 mm

REPAIR PARTS

TRACTOR - - MODEL NUMBER 944.603900

CHASSIS AND ENCLOSURES

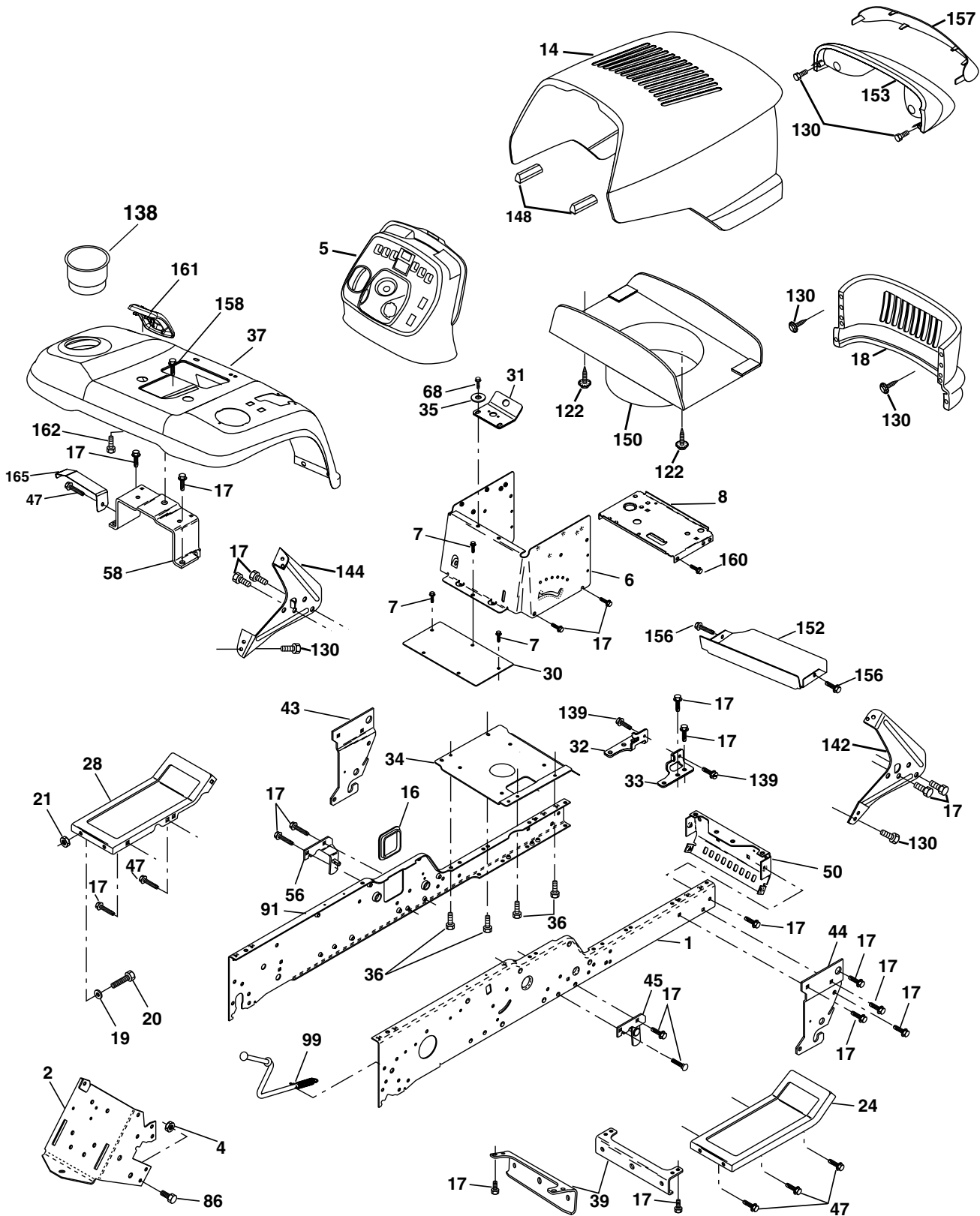

chassis-stealth_43-vgt

REPAIR PARTS

TRACTOR - - MODEL NUMBER 944.603900

CHASSIS AND ENCLOSURES

KEY NO.	PART NO.	DESCRIPTION	KEY NO.	PART NO.	DESCRIPTION
1	180375	Rail, Frame RH	56	176016	Bracket Asm., Susp Chassis Lh
2	175282	Drawbar, Gt	58	183569	Bracket Asm., Fender
5	163976X428	Dash	68	17490508	Screw, Thd 5/16-18 x 1/2
6	157882	Dash Asm., Lower	86	74760716	Bolt, Fin Hex 7/16-14 Unc x 1
7	17720408	Screw, Thd Cut 1/4-20 x 1/2	91	180374	Rail, Frame Lh
8	184668	Support, Battery	99	177143	Rod By Pass
14	175260X615	Hood Asm., Pnt	106	138776	Bolt 5/16-18 Type TT
16	121794X	Cover, Access	122	161464	Screw Hex Wshd 8-18 x 7/8
17	17060612	Screw, 3/8-16 x 3/4	130	171875	Screw HWHD Hi-Lo #13-16 x 3/4
18	174515X615	Grille	138	179125X428	Cupholder YTGt
19	19131312	Washer 13/32 x 13/16 x 12 Ga.	139	171873	Bolt Shoulder 5/16-18 TT
20	STD523710	Bolt, Fin Hex 3/8-16 x 1	142	161897	Bracket Dash RH
21	STD541437	Nut, Crownlock 3/8-16 Unc	144	161900	Bracket Dash LH
24	179717X615	Footrest, RH	148	164655	Extrusion Bumper
28	179716X615	Footrest, LH	150	175352	Duct Heat Hood
30	145052	Saddle, Hydro 1995	152	177956	Shield Browning
31	161419	Bracket, Supt 1-pc VGT Steering	153	179761	Light Box Bar W/Lens
32	161327	Bracket, Pivot Chassis LH	156	17000512	Screw 5/16-18 x 3/4
33	161326	Bracket, Pivot Chassis RH	157	161840	Lens Bar Stealth
34	177018	Bracket, Engine Support Rear	158	17670608	Screw Thdr 3/8-16 x 1/2
35	19111116	Washer 11/32 x 11/16 x 16 Ga.	161	179612X428	Console Fuel Window
36	17060512	Screw 5/16-18 x 3/4	162	142432	Screw Hex Wsh Hi-Lo 1/4-1/2
37	178510X615	Fender, Pnt.	165	183554	Bracket Support Tank
39	175278	Bracket, Axle Front	166	73680700	Nut Crown Lock 7/16-14
43	136939	Bracket, Spnsn Front Lh			
44	136940	Bracket, Spnsn Front Rh			
45	176018	Bracket Asm., Susp Chassis Rh			
47	17490608	Screw Thdrol 3/8-16 x 1/2 TYT			
50	175476	Bracket, Chassis Front			

NOTE: All component dimensions given in U.S. inches
1 inch = 25.4 mm

REPAIR PARTS

TRACTOR - - MODEL NUMBER 944.603900

GROUND DRIVE

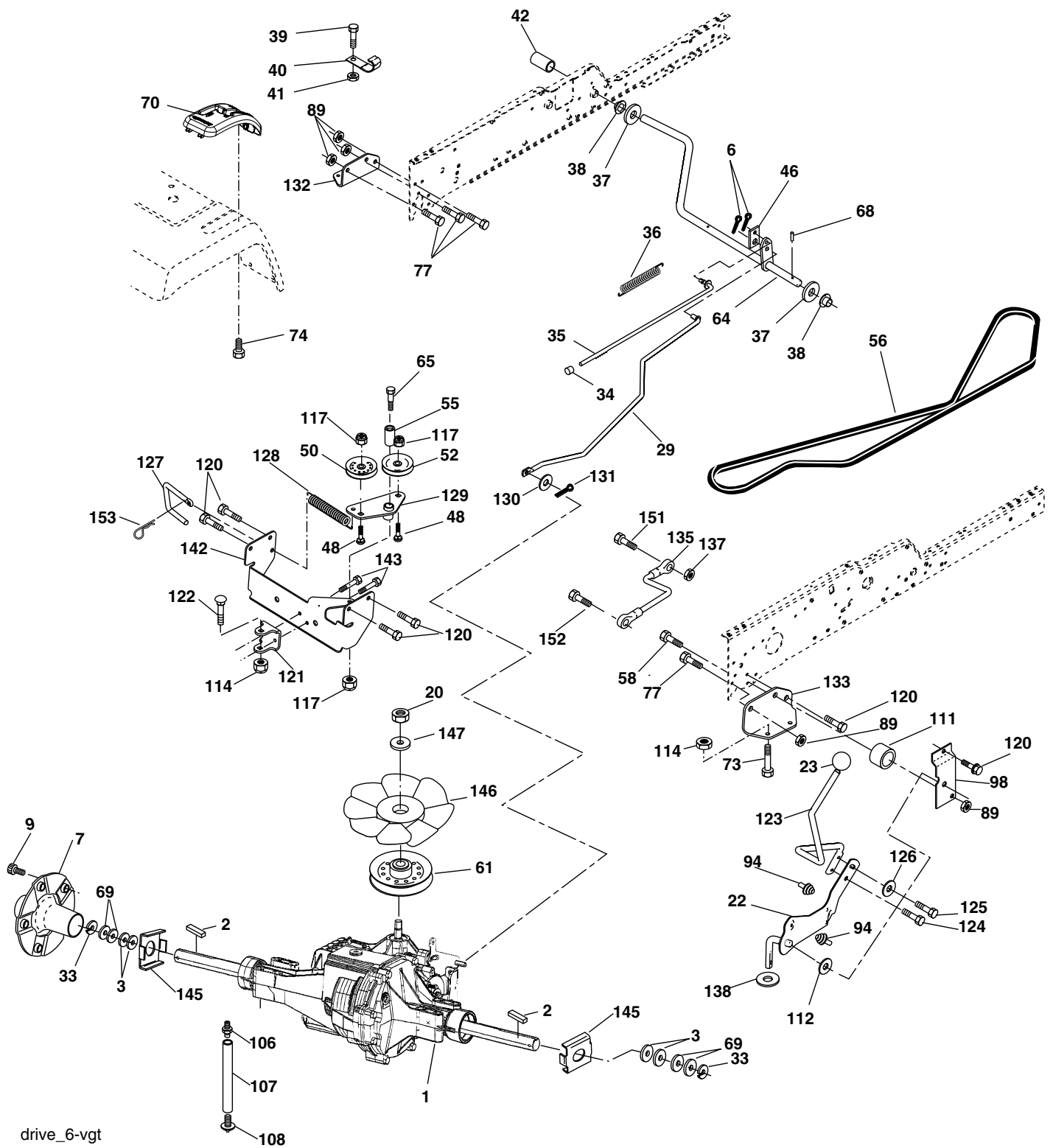

REPAIR PARTS

TRACTOR - - MODEL NUMBER 944.603900

GROUND DRIVE

KEY NO.	PART NO.	DESCRIPTION	KEY NO.	PART NO.	DESCRIPTION
1	-----	Transaxle Hydro Gear 331-3000 (See Breakdown)	98	141004	Bracket Shift
2	7070E	Key Sq. 1/4 x 2.5	106	142918	O-Ring Asm Hydro Gear
3	7563R	Washer Thrust Axle Harden	107	154739	Line Fuel Hydro 15" VGT
6	76020412	Pin, Cotter	108	142917	Cap Asm Vent Hydro Gear
7	140507	Wheel, Hub Assembly	111	156240	Spacer Shift Lever VGTH
9	140080	Bolt, Hub	112	178558	Washer Nylon High Temp
20	73940800	Nut	114	73800500	Nut Lock Hex W/Ins 5/16-18 Unc
22	183254	Rod Shift	117	73900600	Nut, Lock Flg. 3/8-16
23	140845	Knob	120	17060612	Screw 3/8-16 x .75
29	176600	Brake, Rod	121	175611	Bracket Strap Torque
33	12000053	Ring E	122	72010520	Bolt RDHDSQ 5/16-18 Unc x 2-1/2
34	71673	Cap, Parking Brake	123	180235	Lever Asm. Shift Lower
35	137648	Rod, Parking Brake	124	165492	Bolt Shoulder 5/16-18 x .561
36	149412	Spring, Drive Ground	125	166880	Screw 5/16-18 x 5/8
37	121749	Washer 25/32 x 1-1/4 x 16 Ga.	126	166002	Washer SRRTD 5/16 ID x 1.0 x .125
38	150035	Nyliner	127	177362	Link Control Clutch
39	74321016	Screw, Fin. #10-24 x 1	128	176624	Spring Drive GRND
40	178575	Actuator, Interlock Switch	129	179473	Bracket Asm Idler Tensioning
41	73931000	Nut Centerlock 10-24 Unc	130	19131016	Washer 13/32 x 5/8 x 16 Ga.
42	8883R	Cover, Pedal	131	76020312	Pin Cotter 3/32 x 3/4
46	145170	Retainer, Spring	132	175467	Bracket Mtg Hydro 3500 LH VGT
48	72110614	Bolt Rdhd 3/8-16 x 1-3/4 Gr 5	133	175468	Bracket Mtg Hydro 3500 RH VGT
50	131494	Pulley, Idler, Flat	135	177364	Link Asm Control Hydro 3500
52	127783	Pulley, Idler, Grooved	137	1685H	Nut Lock 5/16-18
55	105706X	Bearing, Idler	138	1370H	Washer Thrust 5/8 x 1.10 x 1/32
56	161597	V-Belt	142	175469	Strap Torque HG-3500
58	74760724	Bolt Fin Hex 7/16-14 x 1-1/2	143	17060512	Screw Thdrol 5/16-18 x 3/4
61	143995	Pulley, Transaxle	145	163168	Washer Axle Flange HG-3000
64	176601	Shaft, Brake Pedal	146	140462	Fan 7" Hydro
65	179613	Bolt, Shoulder	147	141322	Washer
68	5142H	Pin, Roll	148	17060612	Screw 3/8-16 x .75
69	123800X	Washer	151	74760514	Bolt Hx 5/16-18 x 7/8
70	179121X428	Console Automatic YT/GT	152	178705	Bolt Hex 5/16-18 x 1 w/Patch
73	74490548	Bolt Hex Flghd 5/16-18 x 3 Gr5	153	4497H	Spring, Retainer
74	142432	Screw Hex Wsh. Hi-Lo 1/4-1/2			
77	74780716	Bolt Fin Hex 7/16-14 x 1			
89	73680700	Nut Crownlock 7/16-14 Unc			
94	133835	Fastener Christmas Tree			

NOTE: All component dimensions given in U.S. inches
1 inch = 25.4 mm

REPAIR PARTS

TRACTOR - - MODEL NUMBER 944.603900

STEERING ASSEMBLY

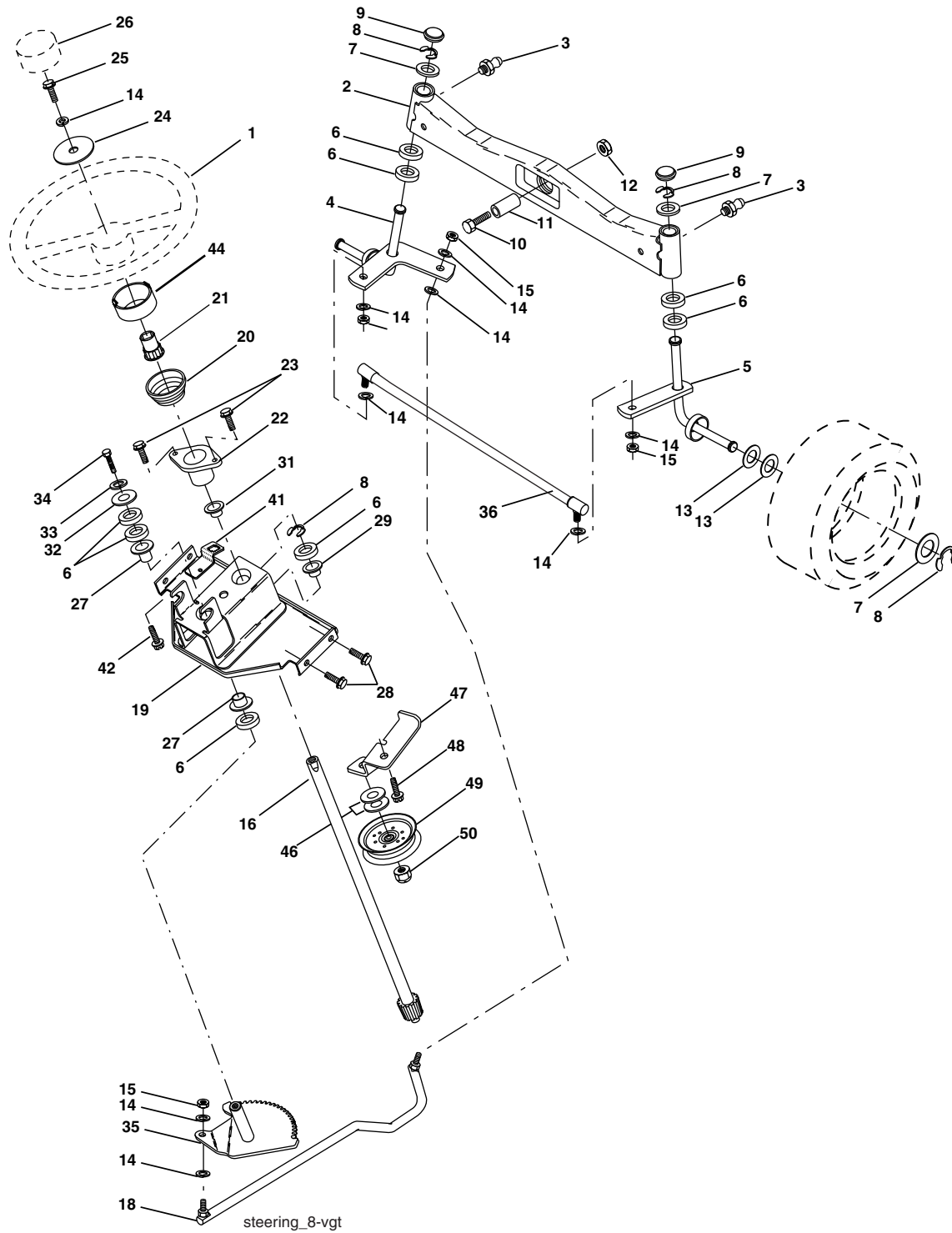

REPAIR PARTS

TRACTOR - - MODEL NUMBER 944.603900

STEERING ASSEMBLY

KEY NO.	PART NO.	DESCRIPTION
1	159944X428	Wheel, Steering
2	178557	Axle Asm., Front
3	6855M	Fitting, Grease
4	161849	Spindle Asm, LH
5	161848	Spindle Asm., RH
6	6266H	Bearing, Race Thrust Harden
7	121748X	Washer 25/32 x 1-5/8 x 16 Ga.
8	12000029	Ring, Klip #T5304-75
9	184946X505	Cap, Spindle
10	74781044	Bolt, Fin Hex 5/8-11 x 2-3/4
11	136518	Spacer, Brg. Axle Front
12	73901000	Nut, Lock Flange 5/8-11 Unc
13	121749X	Washer 25/32 x 1-1/4 x 16 Ga.
14	STD551137	Washer, Lock Hvy Hlcl Spr 3/8
15	STD541537	Nut Lock Center 3/8-24 Unf
16	145103	Shaft Asm., Steering
18	175572	Draglink Vgt
19	156011	Support Asm., Steering Vgt
20	163887X428	Boot Steering Stealth GTYT
21	159945	Adapter, Wheel Steering
22	155105	Bushing, Strg.
23	152927	Screw
25	STD523710	Bolt, Fin Hex 3/8-16 x 1 Gr. 5
26	159946X428	Insert Cap Strg WH
27	3366R	Bearing, Col. Strg.
28	17000612	Screw Hexwsh thdr 3/8-16 x 3/4
29	104239X	Bearing, Flange
31	138136	Bushing, Nyliner Snap
32	19111610	Washer 11/32 x 1 x 10 Ga.
33	STD551131	Washer, Lock Hvy Hlcl Spr 5/16
34	STD523107	Bolt, Hex Hd 5/16-18 x 3/4
35	138059	Gear, Sector Steering
36	186799	Tie Rod
41	155246	Bracket Switch Interlock Vgt 97
42	17490508	Screw Thdrol 5/16-18 x 1/2 Tyt
44	160135X428	Extension Steering
45	19132411	Washer 13/32 x 1-1/2 x 11 Ga
46	19131610	Washer Flat 13/32 x 1 x 10 Ga
47	179471	Bracket Asm Idler Stationary
48	17060612	Screw 3/8-16 x 3/4
49	175820	Pulley Idler
50	73900600	Nut Lock Flg 3/8-16 Unc

NOTE: All component dimensions given in U.S. inches
1 inch = 25.4 mm

REPAIR PARTS

TRACTOR - - MODEL NUMBER 944.603900

ENGINE

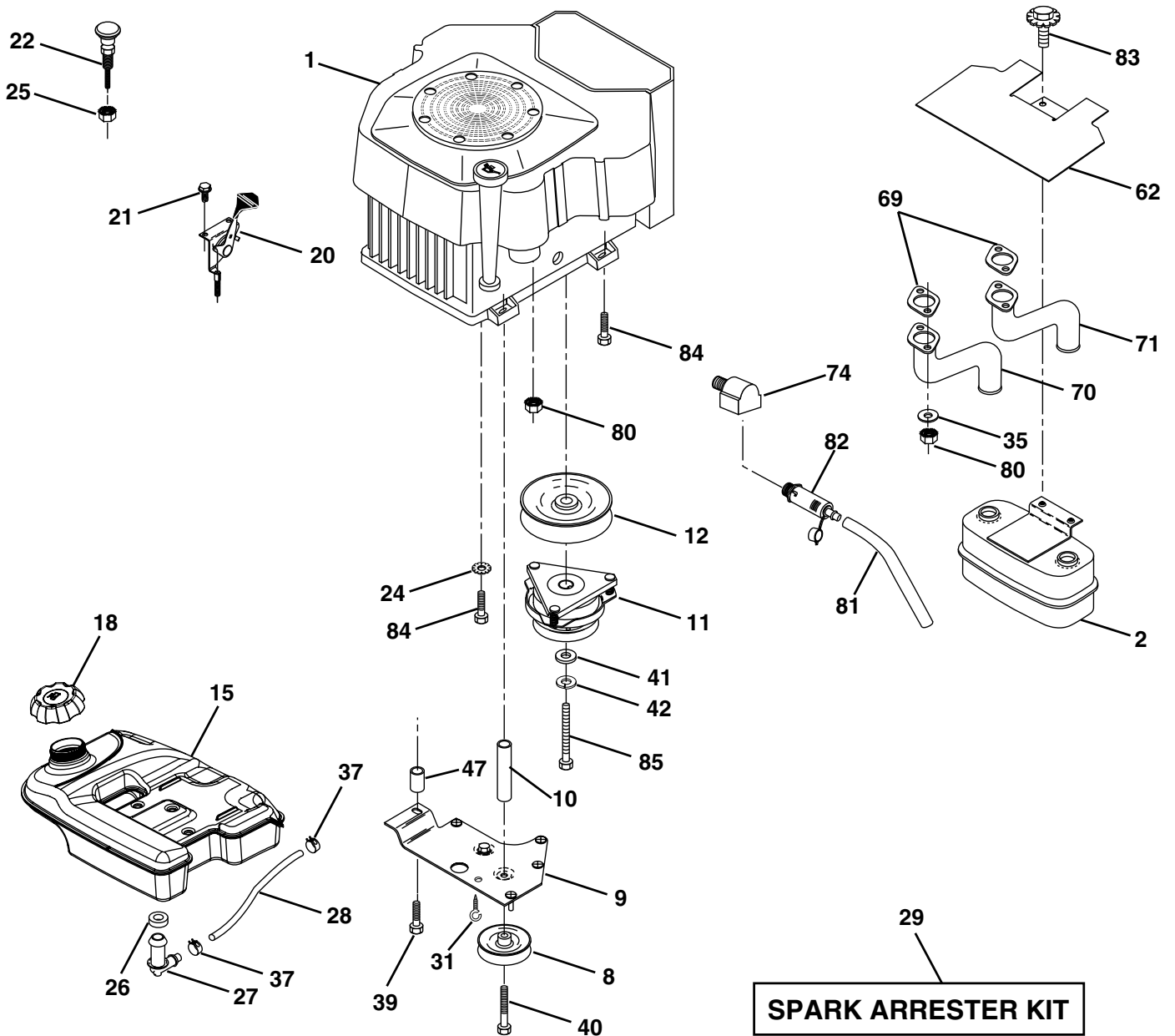

engine-kohler22_14-vgt

REPAIR PARTS

TRACTOR - - MODEL NUMBER 944.603900

ENGINE

KEY NO.	PART NO.	DESCRIPTION
1	-----	Engine (See Breakdown) Kohler CV730-0017
2	149723	Muffler
8	121361X	Pulley V-Idler
9	177748	Keeper Asm Belt Engine Vgt
10	175287	Bushing
11	179335	Clutch Electric
12	143996	Pulley Engine Grnd Drive
15	179115	Tank Fuel Rear
18	179124X428	Cap Asm Fuel
20	177328X428	Control Throttle
21	171875	Screw HWHD Hi-Lo #13-16 x 3/4
22	175441X428	Control Choke
24	STD551237	Lockwasher Ext Tooth 3/8
25	73920600	Nut Keps 3/8-24 Unf
26	3645J	Bushing
27	139277	Stem Tank Fuel
28	7834R	Fuel Line
29	137180	Spark Arrester Kit
31	145006	Clip
35	10010500	Washer Split
37	123487X	Clamp Hose
39	17490636	Screw 3/8 - 16 x 2-1/4 Unc TT
40	17490664	Screw 3/8 - 16 x 4 Unc TT
41	126197X	Washer 1-1/2 OD x 15/32 ID x .250
42	STD551143	Washer Lock 7/16
43	179953	Bolt Hex 7/16-20 x 3-1/4 x Gr. 5-1 Thdrol
47	175288	Bushing
62	146629	Shield Heat Muffler
69	24-041-02	Gasket
70	175546	Tube Exhaust RH
71	175545	Tube Exhaust LH
74	162295	Elbow Street Brass
80	M73030800	Nut Flange M8-1.25
81	148456	Tube Drain Oil Easy
82	181654	Plug Drain Oil Easy
83	171877	Bolt 5/16-18 Unc x 3/4
84	17060624	Screw 3/8-16 x 1-1/2

NOTE: All component dimensions given in U.S. inches
1 inch = 25.4 mm

REPAIR PARTS

TRACTOR - - MODEL NUMBER 944.603900

SEAT ASSEMBLY

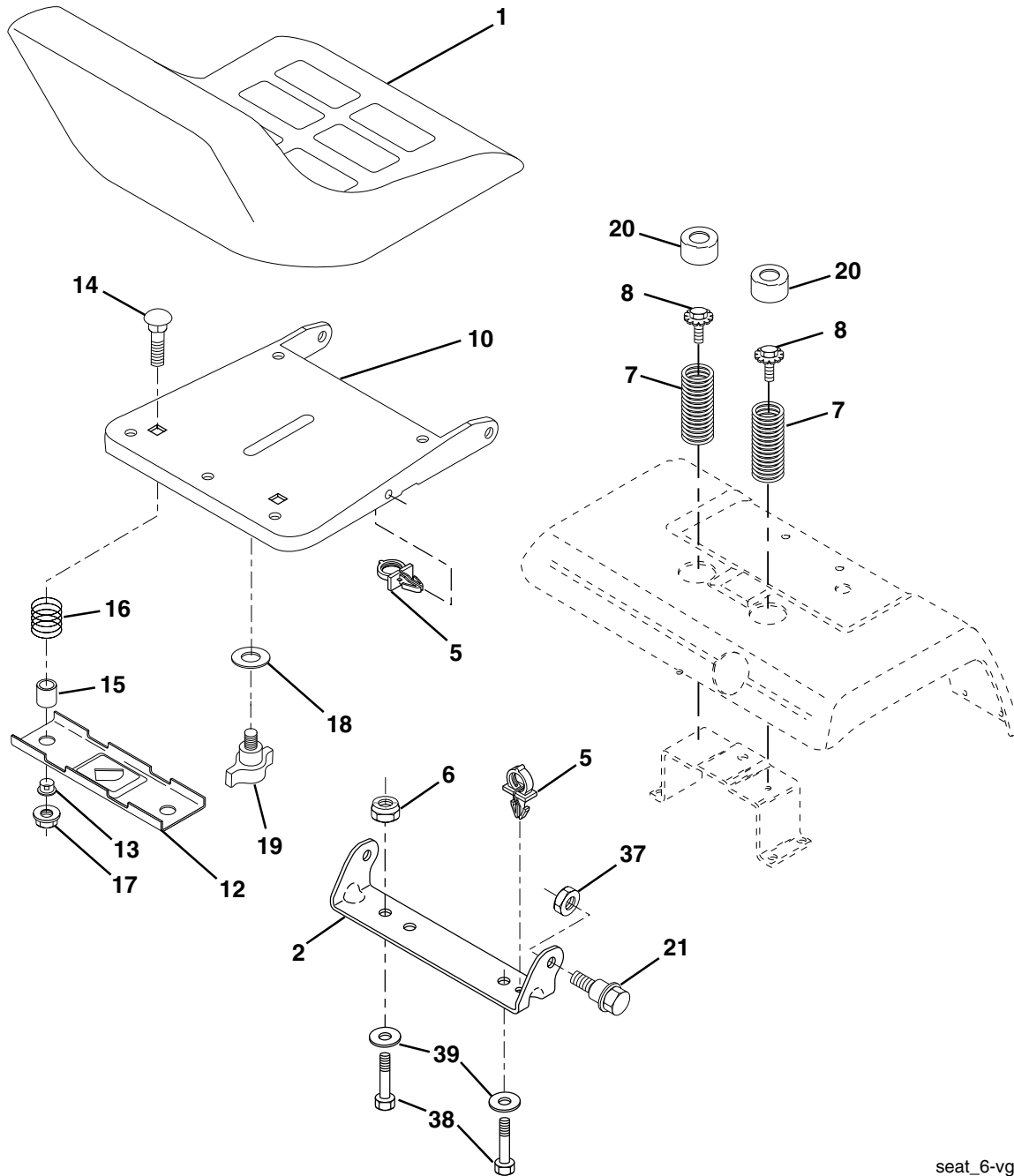

seat_6-vgt

KEY NO.	PART NO.	DESCRIPTION
1	180598	Seat
2	180166	Bracket, Pivot Seat
5	145006	Clip, Push-In Hinged
6	STD541437	Nut, Crownlock 3/8-16
7	124181X	Spring, Seat Cprsn.
8	171877	Bolt 5/16-18 Unc x 3/4 w/Sems
10	180186	Pan, Seat
12	121246X	Bracket, Mounting Switch
13	121248X	Bushing, Snap
14	72050412	Bolt, Carriage 1/4-20 x 1-1/2
15	121249X	Spacer, Split
16	123740X	Spring, Cprsn.

KEY NO.	PART NO.	DESCRIPTION
17	123976X	Nut, Lock 1/4 Lg. Flg. Gr. 5
18	19171912	Washer 17/32 x 1-3/16 x 12 Ga.
19	166369	Knob, Seat
20	124238X	Cap, Spring Seat Blk
21	171852	Bolt 5/16-18 Unc-2A
22	STD541431	Nut, Crownlock 5/16-18
38	71110616	Bolt Hex 3/8-16 x 1
39	19131610	Washer Flat 13/32 x 1 x 10 Ga.

NOTE: All component dimensions given in U.S. inches
1 inch = 25.4 mm

REPAIR PARTS

TRACTOR - - MODEL NUMBER 944.603900

DECALS

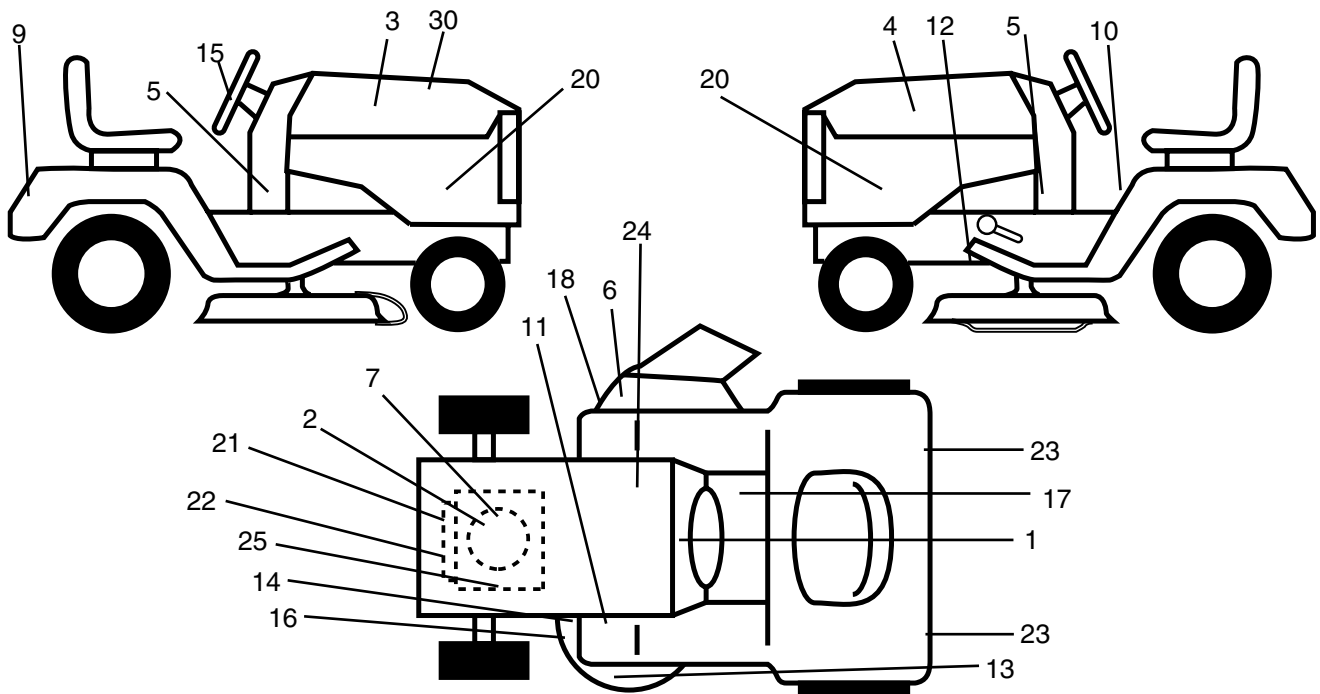

KEY NO.	PART NO.	DESCRIPTION	KEY NO.	PART NO.	DESCRIPTION
1	164097	Decal, Dash	17	140837	Decal, Saddle Brake Parking
2	185982	Decal, Engine	18	181471	Decal, Deck Level
3	186242	Decal, Hood, RH	20	186725	Decal, Hood Side Panel
4	186243	Decal, Hood, LH	21	177914	Decal, Engine
5	177665	Decal, Dash	22	177918	Decal, Engine
6	170563	Decal, Warning	23	106202X	Reflector, Taillight
7	177916	Decal, Engine RH	24	149517	Decal, Btry Dngr/PSn
9	186572	Decal, Craftsman	25	177917	Decal, Engine LH
10	157140	Decal, Danger	30	186903	Decal, Replacement Parts
11	181253	Decal, F/Rest	--	166960	Decal, Drawbar
12	177554	Decal, V-Belt Drive Schematic	--	179768X428	Pad Footrest LH
13	178482	Decal Deck Hvy Dty	--	179769X428	Pad Footrest RH
14	175291	Decal, V-Belt Schematic	--	186793	Manual, Owner's (English)
15	164065	Decal, Ins. Whl. Strg.	--	186794	Manual, Owner's (French)
16	178502	Decal, Deck Caution			

WHEELS & TIRES

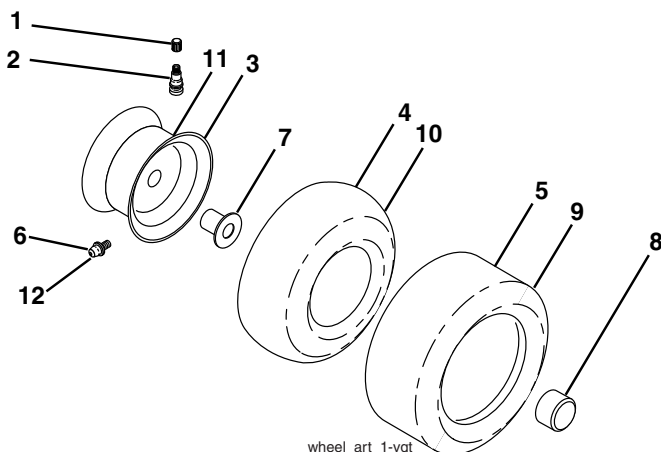

KEY NO.	PART NO.	DESCRIPTION
1	59192	Cap, Valve, Tire
2	65139	Stem, Valve
3	106228X624	Rim Assembly, Front
4	8134H	Tube, Front (Service Item Only)
5	106230X	Tire, Front
6	278H	Fitting, Grease (Front Wheel nly)
7	9040H	Bearing, Flange (Front Wheel Only)
8	104757X428	Cap, Axle (Front Wheel Only)
9	105588X	Tire, Rear
10	7154J	Tube, Rear (Service Item Only)
11	106277X624	Rim Assembly, Rear
12	6856M	Fitting, Grease
--	144334	Sealant, Tire (10 oz. Tube)

NOTE: All component dimensions given in U.S. inches
1 inch = 25.4 mm

REPAIR PARTS

TRACTOR - - MODEL NUMBER 944.603900

LIFT ASSEMBLY

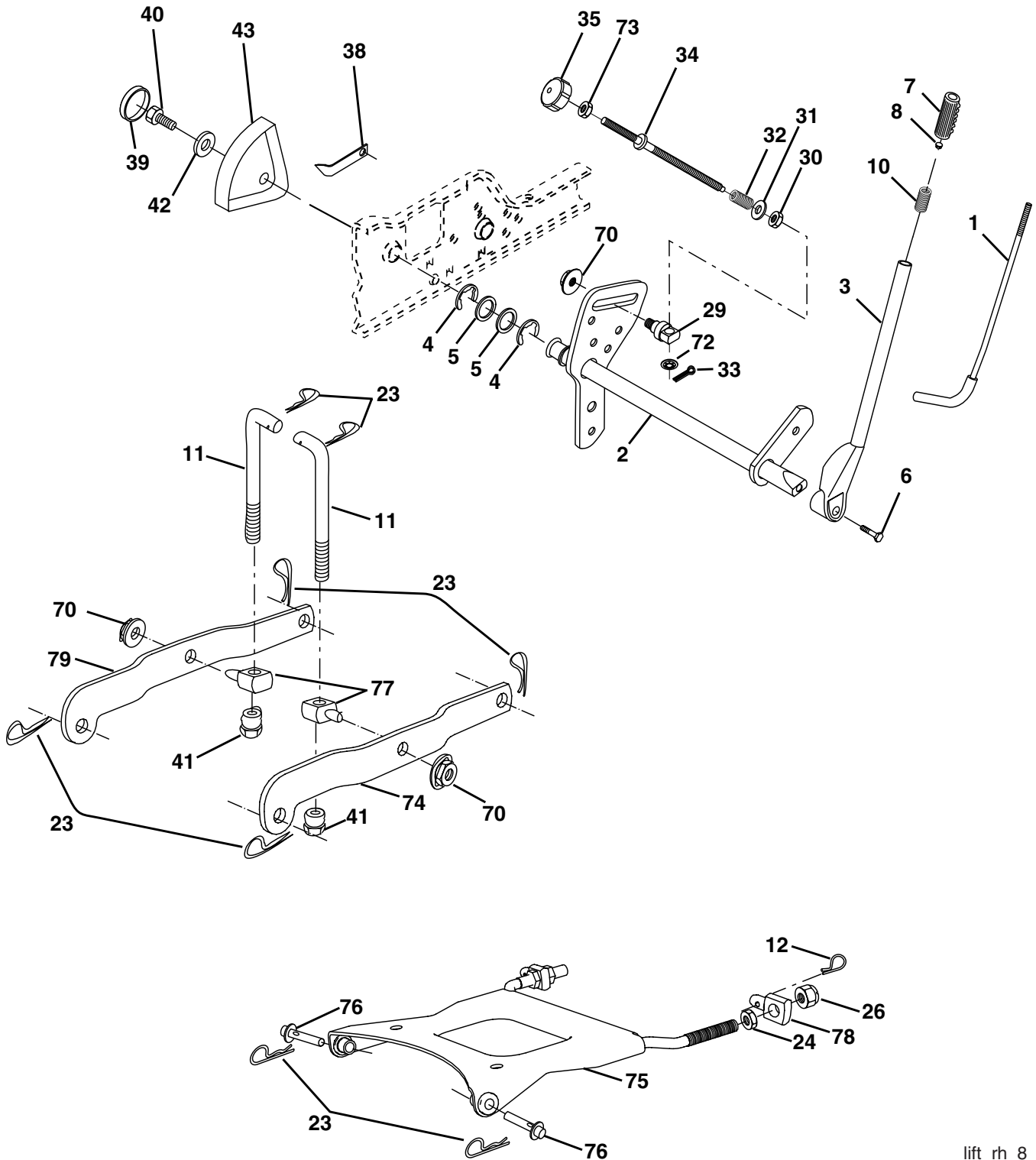

lift_rh_8

REPAIR PARTS

TRACTOR - - MODEL NUMBER 944.603900

LIFT ASSEMBLY

KEY NO.	PART NO.	DESCRIPTION
1	121006X	Rod Asm., Lever
2	180045	Shaft Asm., Lift Vgt
3	159189	Lever Asm., Lift Rh
4	12000022	E-Ring Truarc #5133-87
5	19292016	Washer 29/32 x 1-1/4 x 16 Ga.
6	71110624	Bolt, Fin Hex 3/8-16 x 1-1/2
7	175830	Grip, Handle Fluted
8	175831X505	Button, Plunger
10	183894	Spring 2-1/8"
11	175375	Link Lift
12	163552	Retainer, Spring
23	STD624008	Retainer, Spring
24	73350800	Nut, Jam Hex 1/2-13 Unc
26	73800800	Nut, Lock W/Wsh 1/2-13 Unc
29	150233	Trunnion Inf. Height
30	110807X	Nut, Special
31	19131016	Washer 13/32 x 5/8 x 16 Ga.
32	137150	Spring, Compression Inf Hgt
33	STD560907	Pin, Cotter 3/32 x 1/2
34	137167	Rod, Adj Lift
35	138057	Knob, Inf 3/8-16 Unc
38	155097	Pointer, Height Indicator
39	123935X	Plug, Hole
40	17060516	Screw 5/16-18 x 3/4
41	175994	Nut, Lift Link 7/16-20
42	19112410	Washer 11/32 x 1-1/2 x 10 Ga.
43	123934X	Scale, Indicator Height
70	145212	Nut, Hexflange Lock
72	110452X	Nut, Push Phos & Oil
73	73350600	Nut Hex Jam 3/8-16 Unc
74	175802	Arm Susp RRRH
75	175805	Plate Asm Susp Front
76	175560	Pin Flange
77	176205	Trunnion Susp Arm
78	175689	Trunnion Susp Front
79	175378	Arm Susp RR LH

NOTE: All component dimensions given in U.S. inches
1 inch = 25.4 mm

REPAIR PARTS

TRACTOR - - MODEL NUMBER 944.603900

MOWER DECK

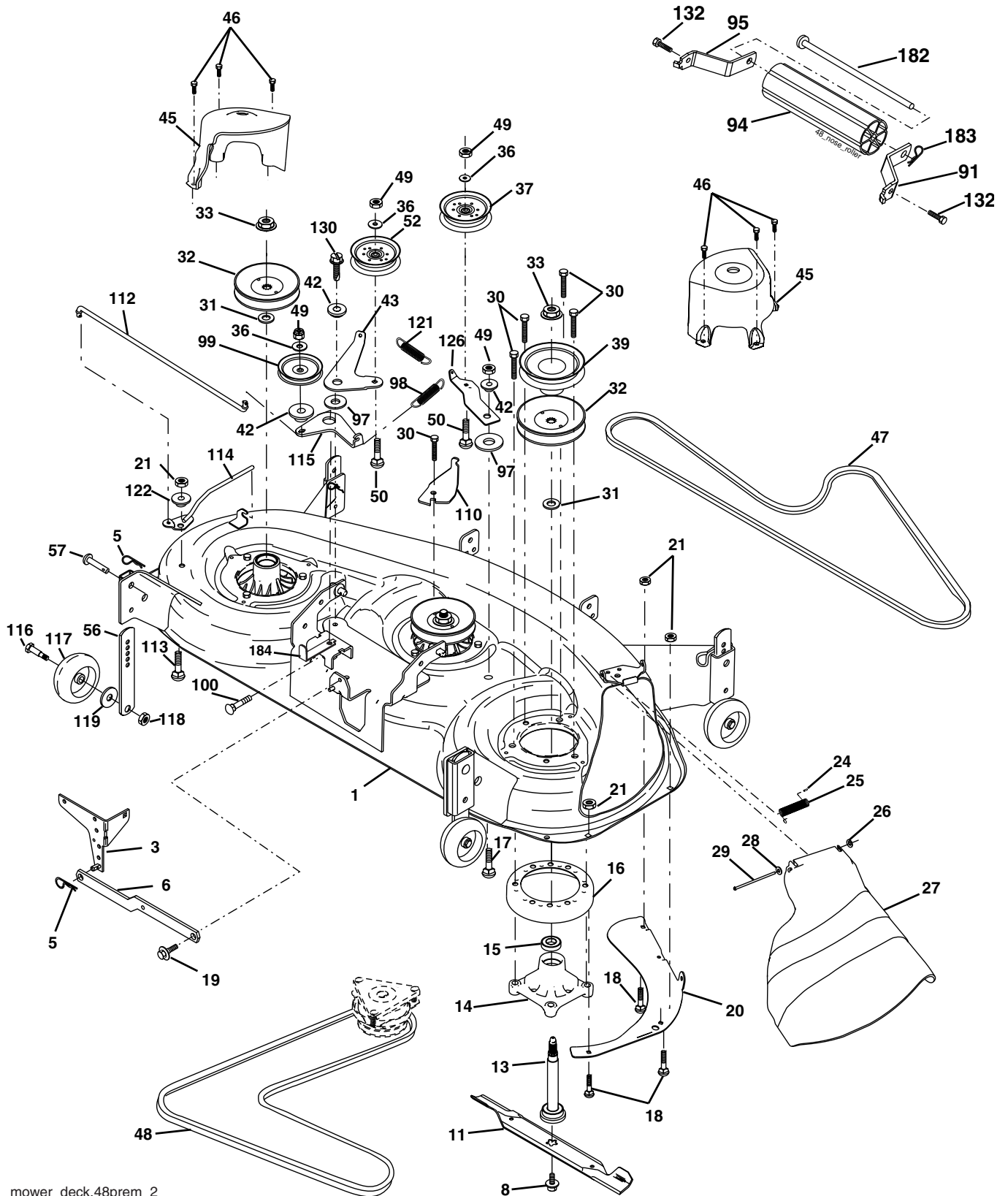

mower_deck.48prem_2

REPAIR PARTS

TRACTOR - - MODEL NUMBER 944.603900

MOWER DECK

KEY NO.	PART NO.	DESCRIPTION	KEY NO.	PART NO.	DESCRIPTION
1	180358	Deck Weldment Mower 48	46	137729	Screw, Thdroll. 1/4-20 x 5/8
3	178915	Bracket Asm., Sway Bar	47	180808	V-Belt, Mower, Secondary
5	4939M	Retainer Spring	48	174368	V-Belt, Mower, Primary
6	178024	Arm, Suspension, Rear (Sway Bar)	49	73680600	Nut, Crownlock 3/8-16 Unc
8	174365	Bolt 7/16 Asm. Blade (The following blades are available)	50	72110612	Bolt, Carr. 3/8-16 x 1-1/2 Gr. 5
11	173921	Blade, 48" Mulching (For mulching mowers only)	52	175820	Pulley Idler Flat
- -	180054	Blade, 48" Hi-Lift (For bagging and discharging)	56	155986	Bar Adj.
13	174360	Shaft Asm.	57	156941	Pin Head Rivet
14	174358	Mandrel Asm.	91	180535	Bracket Asm N Roller RH
15	110485X	Bearing, Ball, Mandrel	94	176066	Roller Nose 48"
16	174493	Stripper Mandrel Deck	95	180534	Bracket Asm N Roller LH
17	72110610	Bolt RDHD Sq Neck 3/8-16 x 1.25	97	178515	Washer Hardened
18	72140505	Bolt, Carriage 5/16-18 x 5/8	98	179479	Spring Primary Drive
19	132827	Bolt, Hex Hd, Shoulder 5/16-18	99	184058	Pulley Idler"V"
20	174378	Baffle, Vortex Mower	110	175016	Arm Spring Secondary
21	73680500	Nut, Crownlock 5/16-18 Unc	112	174387	Link Tension Relief Lever
24	105304X	Cap, Sleeve	113	72110508	Bolt Carr. 5/16-18 x 1
25	178102	Spring, Torsion	114	174384	Tension Asm Relief Lever
26	110452X	Nut, Push	115	174609	Arm Spring Tension Relief
27	180655X428	Deflector Shield	116	184219	Bolt, Shoulder
28	19111016	Washer 11/32 x 5/8 x 16 Ga.	117	174873	Gauge Wheel, Rally
29	131491	Rod, Hinge	118	73930600	Nut, Centerlock 3/8-16 Unc
30	173984	Screw, Thdroll	119	19121414	Washer 3/8 x 7/8 x 14 Ga.
31	129963	Washer, Spacer Mower Vented	121	174371	Spring Secondary Drive
32	177865	Pulley, Mandrel	122	174606	Bushing Pivot Tension Relief
33	178342	Nut, Flg. Top Lock Cntr. 9/16	126	174372	Arm, Idler, Primary Deck
36	19131316	Washer 13/32 x 13/16 x 16 Ga.	130	17000616	Screw 3/8-16 x 1.0
37	177968	Pulley, Idler, 48" Primary	132	17000612	Screw 3/8-16 x .75
39	174375	Pulley, Idler, Driven	182	179127	Rod Nose Roller
42	165723	Spacer, Retainer	183	163552	Retainer Spring
43	174373	Arm, Idler Secondary	184	173979	Keeper Belt Idler
45	180806	Cover, Mandrel Deck	- -	181579	Replacement Deck, Complete
			- -	174356	Mandrel Asm. Service (Includes Key Nos. 13-15)

NOTE: All component dimensions given in U.S. inches
1 inch = 25.4 mm

REPAIR PARTS

TRACTOR - - MODEL NUMBER 944.603900

HYDRO GEAR TRANSAXLE - - MODEL NUMBER 331-3000

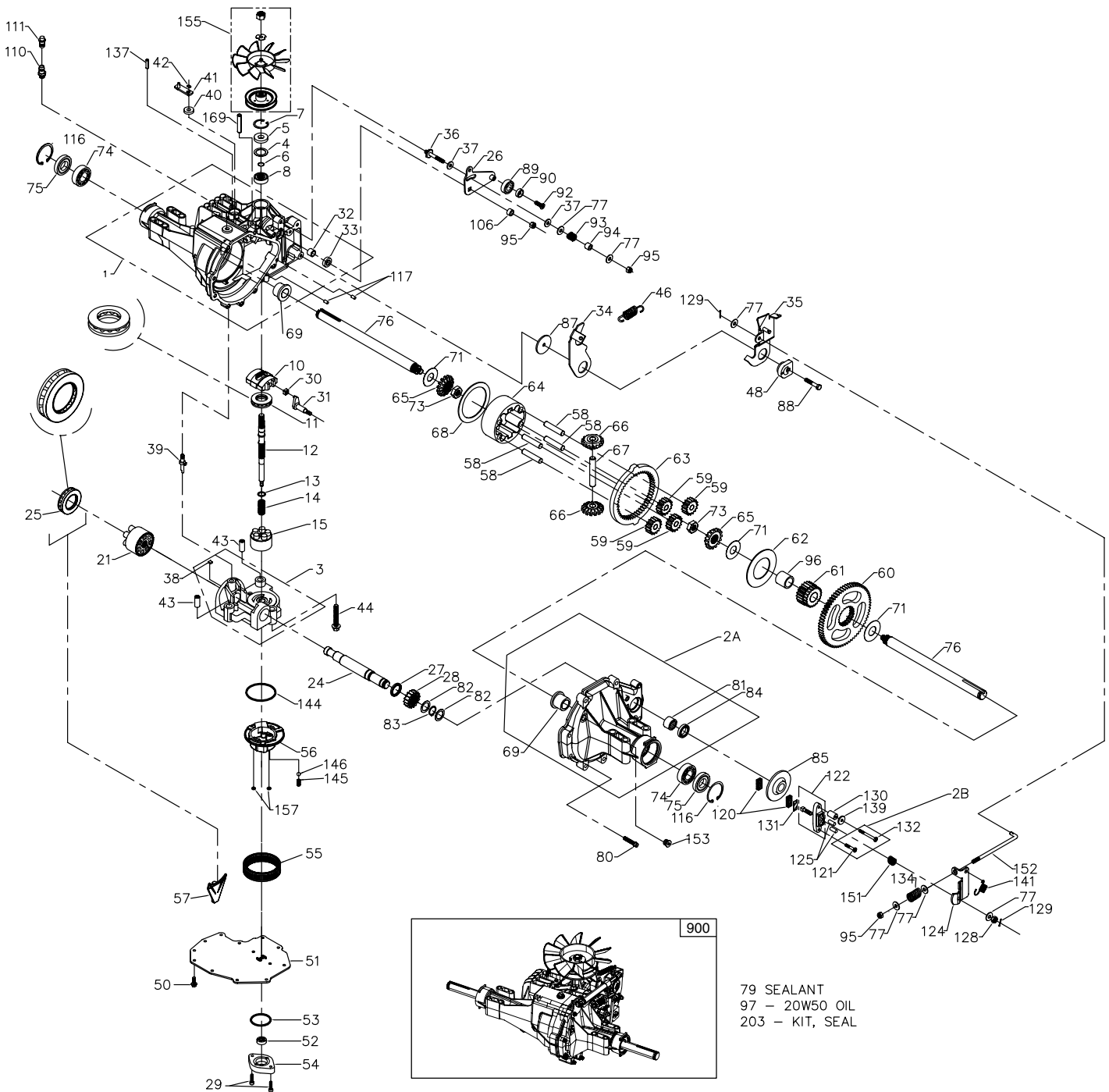

REPAIR PARTS

TRACTOR - - MODEL NUMBER 944.603900

HYDRO GEAR TRANSAXLE - - MODEL NUMBER 331-3000

Key No.	Part No.	Description	Key No.	Part No.	Description
1	161122	Kit, housing main	65	161150	Gear, differential bevel (310-3000)
		Main housing	66	161151	Gear, differential bevel pinion (310-3000)
		Lip seal	67	161152	Shaft, differential (310-3000)
		Flange bearing	68	161153	Plate, differential thrust (310-3000)
		Trunnion bushing	69	169534	Bearing, flange (310-3000)
		Cradle bearing	71	161155	Washer, flat (1.00 ld) (310-3000)
2A	193015	Kit, housing r/h	73	161156	Nut, 5/8-18 hex jam (310-3000)
		R.H. Housing	74	169535	Bearing, ball (310-3000)
		Flange bearing	75	161157	Seal, lip (310-3000)
		Needle bearing (sce1412)	76	161158	Shaft, axle (310-3000)
		Lip seal (.875 ID x 1.3 OD x .25)	77	142884	Washer, flat
2B	193016	Kit, brake bolt	79	178322	Sealant tube
		Bolt, hex hd 1/4-20 x 1.25 W/patch	80	161159	Screw, torx head 5/16-18 (310-3000)
		Bolt, hex hd 1/4-20 x 2.25 W/patch	81	161160	Bearing, needle (210-3000)
3	184703	Kit, center section	82	161161	Washer, flat (0.880 ID) (310-3000)
		Center section	83	161162	Ring, retaining (310-3000)
		Bushing .50 X .60 X .50	84	161163	Seal, lip (.875 ID x 1.38 OD x .25) (310-3000)
		Bushing .90 X 1.02 X .75	85	161164	Brake disc (310-3000)
		Plate, bypass	87	178323	Washer (310-3000)
		Check plug assembly,.044	88	178784	Screw, 5/16-24x 1 1/2 socket head cap (310-3000)
		Check plug assembly, no bleed	89	178783	Bearing, ball
4	161125	Spacer (BDP, BDU 10)	90	178326	Spacer, locating (310-3000)
5	142932	Seal, lip	92	178787	Screw (310-3000)
6	142928	Retaining ring	93	142969	Spring
7	142933	Retaining ring	94	142980	Spacer
8	142934	Bearing, ball	95	169537	Nut, nylon insert hex lock 5/16-24
10	169524	Swash plate (BDP, BDU 10)	96	169538	Bearing, sleeve (310-3000)
11	173159	Bearing, thrust (10cc)	97	-----	20W-50 oil 122 oz
12	161126	Shaft, input (310-3000)	106	161166	Spacer, trunnion (310-3000)
13	142978	Washer, block thrust	108	150800	Plug, plastic shipping
14	142977	Spring, helical compression	110	150813	O-ring
15	169898	Kit, cylinder block (10cc)			Fitting, plastic hose
		10CC cylinder block			O-ring
		10CC piston			Breather vent, plastic
		10CC piston spring			Vent, plastic
		Piston seat washer			Vent, cap
21	150786	Block, (BD-21& IHT)	111	150812	Ring, retaining (310-3000)
		21CC Cylinder block	116	169539	Pin
		Piston seat washer	117	161168	Brake puck
		21CC piston	120	142883	Bolt, hex hd 1/4-20 x 1.25 W/patch
		21CC piston spring	121	193019	Kit, brake yoke
24	161127	Shaft, motor (310-3000)	122	178329	Brake arm
25	169526	Bearing, thrust (21cc)	124	178330	Pin, brake actuating
26	161128	Control arm (310-3000)	125	170409	Nut, castle 5/16-24
27	161129	Spacer (310-3000)	128	170415	Pin, cotter 3/32x3/4
28	161130	Gear, 16t pinion	129	170416	Spacer, brake torsion spring
29	169527	Capscrew	130	170411	Brake puck plate
30	142941	Guide block (BD-21)	131	142882	Bolt, hex hd 1/4-20 x 2.25 W/patch
31	169887	Trunnion, tapered square	132	193020	Brake comp. Spring
32	161133	Bearing, journal	134	178331	Pin, spring (310-3000)
33	142940	Seal, lip	137	178333	Washer, flat
34	178318	Return arm (310-3000)	139	161176	Spring, brake arm bias
35	178319	Actuating arm (310-3000)	141	178335	O-ring
36	170421	Bolt, stud 5/16-24	144	169545	Spring, relief
37	142967	Friction puck	145	169546	Steel ball 7/16
38	184694	Kit, bypass plate	146	169547	Brake spring
39	169529	Bypass actuator (IHT)	151	170417	Brake pull rod
40	142945	Seal, lip	152	178336	Plug, straight thread 9/16-18
41	142952	Bypass arm	153	170434	Kit, fan/pulley
42	142953	Retaining ring	155	178337	Nut, jam 1/2-20
43	142965	Pin			Washer, OD slotted .53 X 1.63 X .06
44	150797	Bolt 3/8-24 x 2-1/2			Pulley
46	184702	Spring, neutral (310-3000)			Fan
48	178320	Puck, adjusting (310-3000)	157	169548	O-ring
50	178343	Screw, hex head washer cap screw (LZT) 1/4-20 x 3/4	169	184701	Pin, spring 5/16 x 1.75
		Lower cover	203	178338	Kit, seal
51	169530	Geroter assembly			Lip seal 15 x 5 x 37
52	169531	O-ring			Lip seal 12 x 25 x 7
53	144581	Charge pump housing			Lip seal 10 x 25 x 7
54	161139	Kit, filter			O-ring .103 X 1.862
55	178321	Gasket .10 X .16 X 4.24			Seal 25 x 52 x 10
		Filter			Lip seal .875 ID x 1.3 OD x .25
56	169533	Charge manifold 310-3000			O-ring .070 X .239
57	161142	Retainer, motor bearing (310-3000)			Kit, o-ring, manifold
58	161143	Pin, carrier (310-3000)			Pin, spring 5/16 x 1.75
59	161144	Gear, 15t planet (310-3000)			Pin, spring 1/4 x 1.00
60	161145	Gear, 67t spur (310-3000)	900	176056	Transaxle
61	161146	Gear, 21t sun (310-3000)			
62	161147	Plate, planet thrust (310-3000)			
63	161148	Gear, 51t ring (310-3000)			
64	161149	Carrier, planetary (310-3000)			

Note: All Component Dimensions Given In U.s. Inches
1 Inch = 25.4 MM

REPAIR PARTS

TRACTOR - - MODEL NUMBER 944.603900

KOHLER ENGINE - MODEL NUMBER CV730, TYPE NUMBER 0017

CYLINDER HEAD, VALVE AND BREATHER

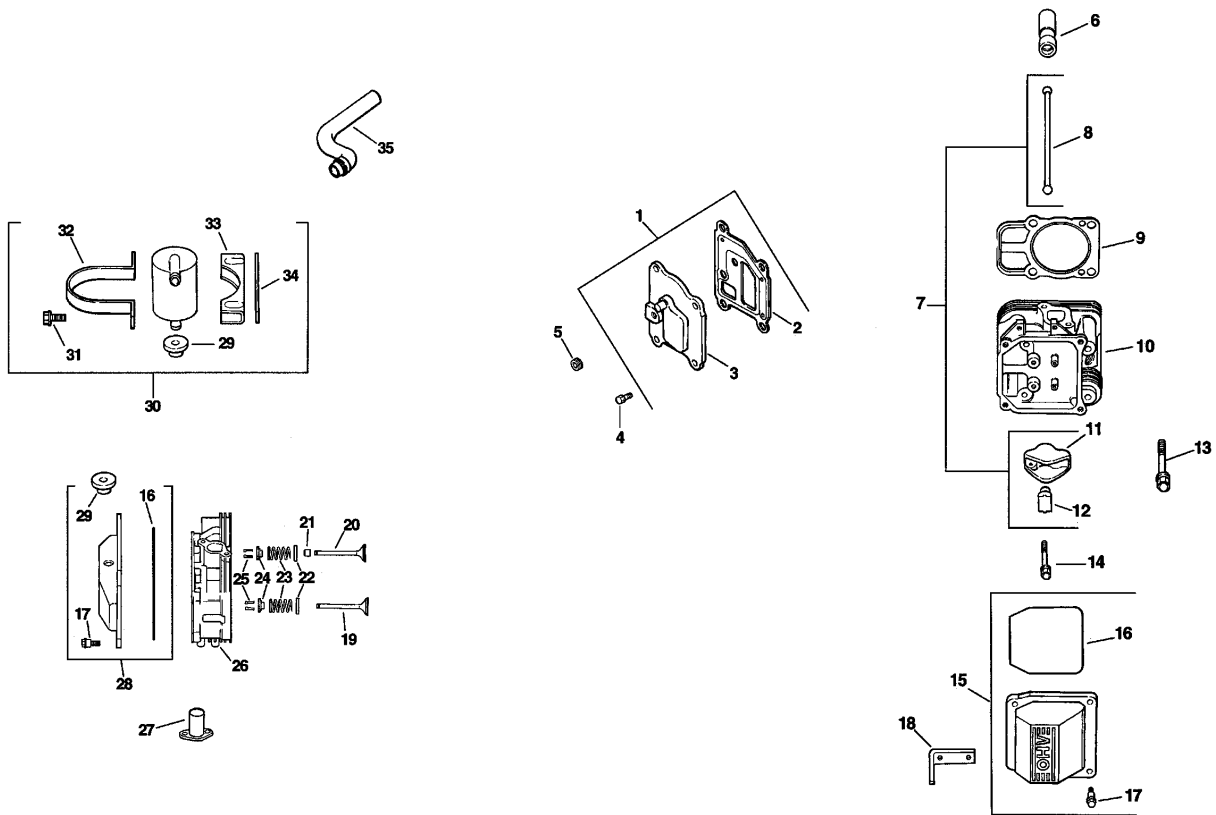

CRANKCASE

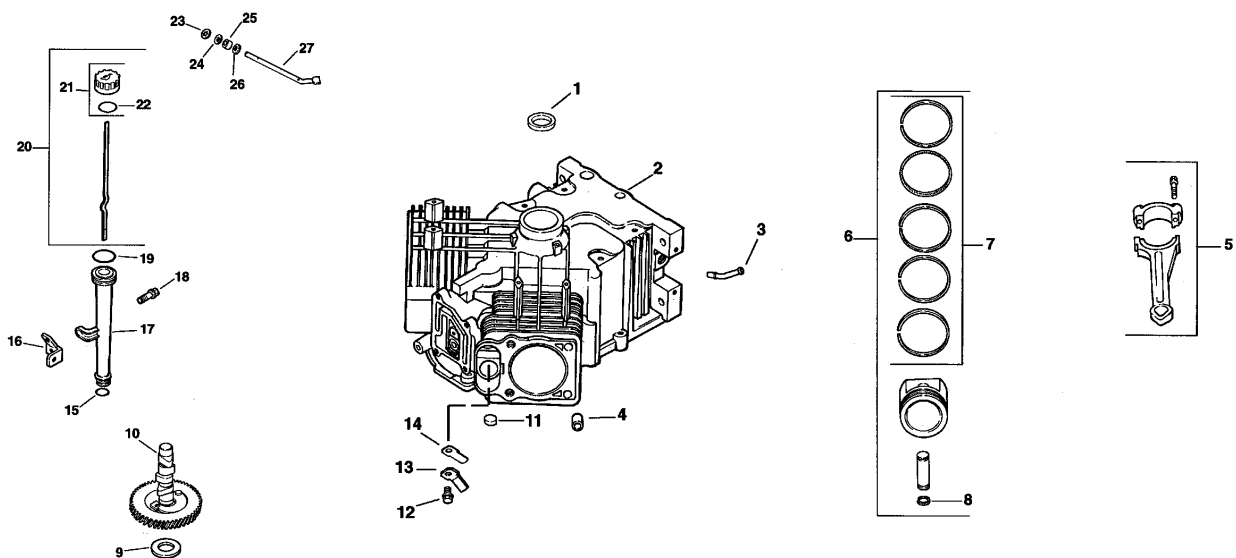

REPAIR PARTS

TRACTOR - - MODEL NUMBER 944.603900

KOHLER ENGINE - MODEL NUMBER CV730, TYPE NUMBER 0017

HEAD/VALVE/BREATHER

KEY NO.	PART NO.	DESCRIPTION
1.	24-033-03-S	Kit, breather cover w/gasket (Includes 2, 3)
2.	24-041-23-S	Gasket, breather
3.	24-096-87-S	Cover, breather
4.	M-645020-S	Screw, hex. flange M6x1.0x20 (4)
5.	25 139 60-S	Plug, hex. ctsk. 1/8"
6.	25-351-01-S	Lifter, valve (4)
7.	24-755-66-S	Kit, valve train (Includes 8, 11, 12)
8.	24-411-05-S	Rod, push (4)
9.	24-041-37-S	Gasket, cylinder head (2)
10.	24-318-72-S	Head assembly, #2 cylinder
11.	25-186-01-S	Arm, rocker (4)
12.	24-599-01-S	Pivot, rocker arm (4)
13.	12 086 16-S	Screw, hex. flange M10x1.5x90 (4)
14.	M-640034-S	Screw, hex. flange M6x1.0x34 (4)
15.	24-755-74-S	Kit, valve cover - plain (Includes 16,17)
16.	24-153-23-S	O-Ring
17.	24-086-32-S	Screw, shoulder M6x1.0x30 (4)
18.	24-445-01-S	Strap, lifting
19.	24-016-01-S	Valve, exhaust (Std.) (2)
	24-016-02-S	Valve, exhaust (.25) (2)
20.	24-017-01-S	Valve, intake (Std.) (2)
	24-017-02-S	Valve, intake (.25) (2)
21.	66-032-05-S	Seal, valve stem (2)
22.	235011-S	Retainer, spring (4)
23.	24-089-02-S	Spring, valve (4)
24.	12-173-01-S	Cap, valve spring (4)
25.	12-755-03-S	Kit, retainer (4)
26.	24-318-69-S	Head assembly, #1 cylinder
27.	24 605 01-S	Liner, exhaust port (2)
28.	24-755-76-S	Kit, valve cover - breather (Includes 16,17,29)
29.	25-313-03-S	Grommet, rubber
30.	24-755-57-S	Kit, breather separator (Includes 29,31-34)
31.	M-545016-S	Screw, hex. flange M5x0.8x16 (2)
32.	24-445-01-S	Strap, breather
33.	24-126-44-S	Bracket, breather separator
34.	24-112-12-S	Spacer
35.	24-326-55-S	Hose, breather

CRANKCASE

KEY NO.	PART NO.	DESCRIPTION
1.	24-032-01-S	Seal, front oil
2.		Crankcase (USE: Miniblock 24 782 14)
3.	24-294-13-S	Fitting
4.	24-380-13-S	Pin, locating (6)
5.	24-067-13-S	Connecting Rod (Std.) (2)
	24-067-14-S	Connecting Rod (.25) (2)
6.	24-874-08-S	Piston w/Ring Set (Std.) (2) (Includes 7, 8)
	24-874-16-S	Kit, piston w/ring set (.08)
7.	24-108-05-S	Ring Set (Std. & .08) (2)
8.	24-018-01-S	Retainer, piston pin (4)
9.	12-422-09-S	Shim, camshaft (A.R.)
	12-422-13-S	Shim, camshaft (A.R.)
	12-422-07-S	Shim, camshaft (A.R.)
	12-422-08-S	Shim, camshaft (A.R.)
	12-422-10-S	Shim, camshaft
	12-422-11-S	Shim, camshaft (A.R.)
	12-422-12-S	Shim, camshaft (A.R.)
10.	24-012-16-S	Camshaft
11.	52-139-09-S	Plug, cup
12.	M-545010-S	Screw, hex. flange M5x0.8x10 (2)
13.	24-018-04-S	Retainer, reed (2)
14.	24-402-05-S	Reed, breather (2)
15.	12-153-01-S	O-Ring, lower oil fill tube
16.	24-126-19-S	Bracket, oil fill tube
17.	12-123-04-S	Tube, oil fill
18.	M-545016-S	Screw, hex. flange M5x0.8x16
19.	12-153-02-S	O-Ring, upper oil fill tube
20.	24-038-04-S	Dipstick assembly (Includes 21, 22)
21.	24-755-46-S	Kit, oil fill cap (Includes 22)
22.	25 153 02-S	O-Ring, dipstick
23.	24-018-09-S	Ring, retainer
24.	M-931010-S	Washer, nylon (top)
25.	28-032-09-S	Seal, governor cross shaft
26.	24-468-15-S	Washer (bottom)
27.	24-144-38-S	Shaft, governor cross

NOTE: All component dimensions given in U.S. inches
1 inch = 25.4 mm

REPAIR PARTS

TRACTOR - - MODEL NUMBER 944.603900

KOHLER ENGINE - MODEL NUMBER CV730, TYPE NUMBER 0017

IGNITION/ELECTRICAL

KEY NO.	PART NO.	DESCRIPTION
1.	54-755-15-S	Kit, grass screen (Includes 2-4)
2.	M-403025-S	Screw, hex. cap M4x0.7x25 (4)
3.	X-25-92-S	Washer, plain 5/16" (4)
4.	24-112-04-S	Spacer, grass screen (4)
5.	25-086-47-S	Bolt, shoulder M6x1.0x16 (4)
6.	24-157-08-S	Fan
7.	12-086-14-S	Screw, hex. flange M10x1.5x46
8.	12-468-03-S	Washer, plain 3/8"
9.	X-42-15-S	Key
10.	24-025-01-S	Flywheel
11.	25-403-03-S	Rectifier-regulator
12.	X-25-92-S	Washer, plain 3/16" (2)
13.	24-086-18-S	Screw, phillips hd. 11-16x7/8 (2)
14.	236602-S	Connector (3 contact)
15.	12-132-06-S	Spark Plug (2)
16.	M-548025-S	Screw, hex. cap M5x0.8x25 (2)
17.	54-755-09-S	Kit, 15 amp stator (Includes 18)
18.	24 126 71-S	Bracket, stator wire
19.	48-154-02-S	Clip, cable
20.	X-25-63-S	Washer, plain 1/4"
21.	24-584-01-S	Module, ignition (2)
22.	M-545020-S	Screw, hex flange M5x0.8x20 (4)
23.	235173-S	Clip, cable
NOT ILLUSTRATED		
	X-22-11-S	Washer, lock 1/4"
	24-176-82-S	Harness, wiring
	24-518-12-S	Lead, black (rect.-reg. 6"-12 gauge insulated grip barrel eyelets)
	25-454-03-S	Tie, wire (3)

BLOWER HOUSING & BAFFLES

KEY NO.	PART NO.	DESCRIPTION
1.	24-027-114-S	Housing, blower (Includes 2)
2.	24-100-01-S	Nut, plastic (2)
3.	M-551016-S	Screw, hex. flange M5x0.8x16
4.	M-545016-S	Screw, hex. flange M5x0.8x16 (3)
5.	M-545020-S	Screw, hex. flange M5x0.8x20 (4)
6.	M-645016-S	Screw, hex. flange M6x1.0x16 (6)
7.	24-146-16-S	Plate, backing - # 2 side
8.	24-146-20-S	Plate, backing - # 1 side
9.	24-063-20-S	Baffle, cylinder barrel - # 2 side
10.	24-063-58-S	Baffle, cylinder barrel - # 1 side
11.	M-545010-S	Screw, hex. flange M5x0.8x10 (2)
12.	24-063-14-S	Baffle, valley - #2 side
13.	24-063-60-S	Baffle, valley - #1 side
NOT ILLUSTRATED		
	24-096-85-S	Cover, blower housing
	25-086-91-S	Screw, tapping 10-16x1/2" (2)

AIR INTAKE/FILTRATION

KEY NO.	PART NO.	DESCRIPTION
1.	54-755-01-S	Kit, knob with seal (Includes 2,3)
2.	25-341-03-S	Knob, cover
3.	24-153-20-S	O-Ring
4.	24-096-67-S	Cover, air cleaner
5.	12-100-01-S	Wing Nut
6.	24-096-01-S	Cover, inner air cleaner
7.	231032-S	Seal, breather
8.	24-083-05-S	Precleaner, element
9.	24-083-03-S	Element, air cleaner
10.	24-109-09-S	Cup, fuel spit-back
11.	24-041-13-S	Gasket, fuel spit-back cup
12.	24-094-34-S	Base, air cleaner
13.	24-041-14-S	Gasket, air cleaner base
14.	24-164-51-S	Manifold, intake (Includes 15,16)
15.	24 041 52-S	Gasket, carburetor
16.	24 153 27-S	O-Ring, intake port (2)
17.	M-651040-S	Screw, hex. flange M6x1.0x40 (4)
18.	24 126 130-S	Bracket, air cleaner base
19.	M-545010-S	Screw, hex. flange M5x0.8x10 (2)
20.	24-063-51-S	Baffle, spit-back cup

NOTE: All component dimensions given in U.S. inches
1 inch = 25.4 mm

REPAIR PARTS

TRACTOR - - MODEL NUMBER 944.603900

KOHLER ENGINE - MODEL NUMBER CV730, TYPE NUMBER 0017

STARTING SYSTEM

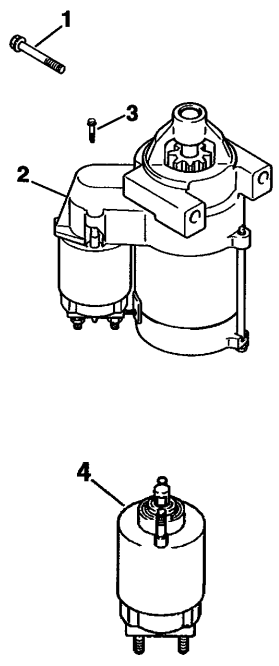

ENGINE CONTROLS

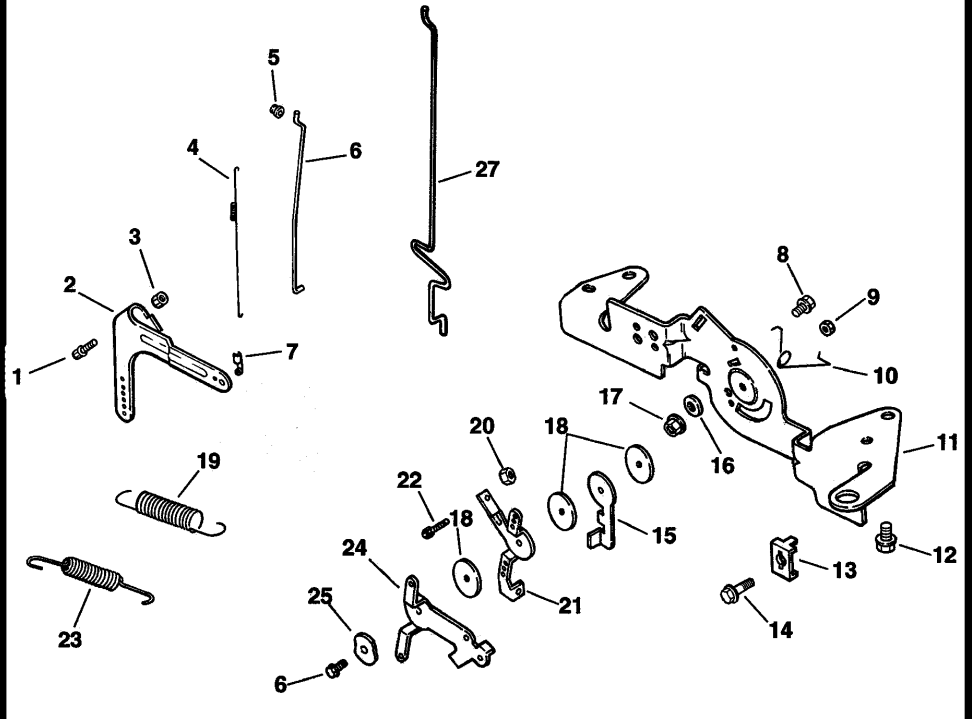

OIL PAN / LUBRICATION

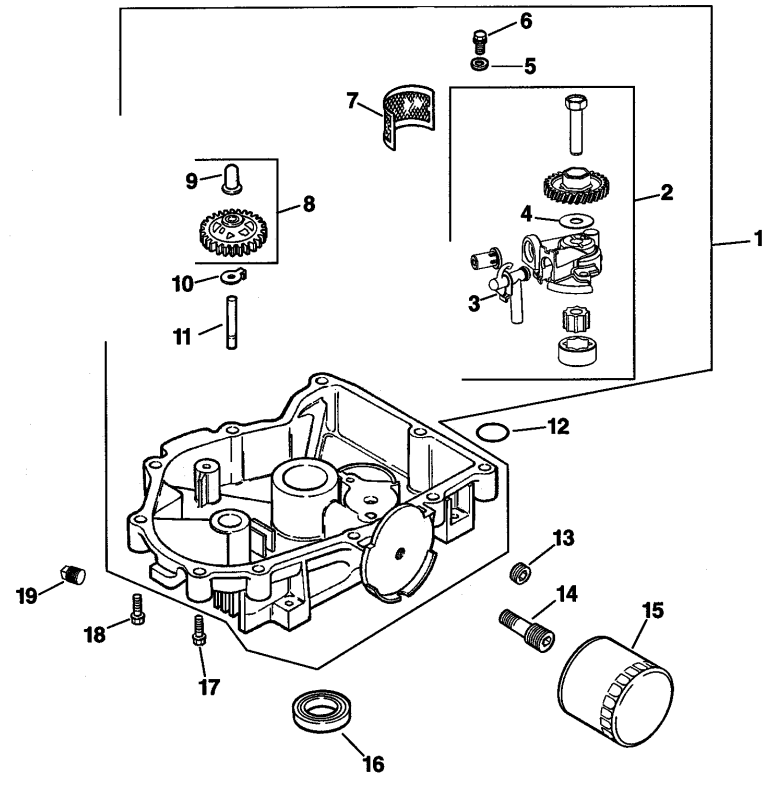
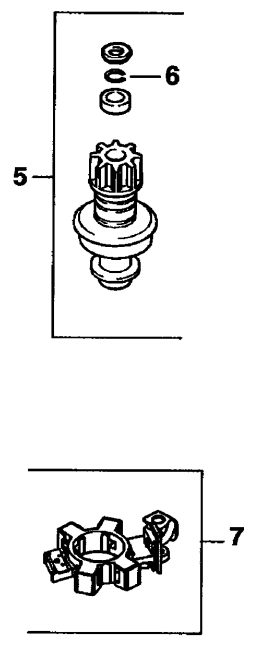

REPAIR PARTS

TRACTOR - - MODEL NUMBER 944.603900

KOHLER ENGINE - MODEL NUMBER CV730, TYPE NUMBER 0017

STARTING SYSTEM

KEY PART NO. NO.	DESCRIPTION
1. M-839080-S	Screw, hex. flange M8x1.25x80 (2)
2. 25-098-09-S	Starter, solenoid shift (Includes 3-7)
3. 25 086 113-S	Screw, external torx hd. (3)
4. 25-435-05-S	Kit, solenoid (Includes 3)
5. 25-755-33-S	Kit, pinion drive (Includes 6)
6. 25-141-05-S	Ring
7. 25-221-01-S	Kit, brush

ENGINE CONTROLS

KEY PART NO. NO.	DESCRIPTION
1. 24 211 03-S	Bolt, round head square neck
2. 24-090-33-S	Lever, governor
3. M-641060-S	Nut, hex. flange M6x1.0
4. 24-089-01-S	Spring, linkage
5. 25-158-08-S	Bushing, linkage retaining
6. 24-079-04-S	Linkage, throttle
7. 25-158-11-S	Bushing, throttle linkage
8. M-545016-S	Screw, hex. flange M5x0.8x16
9. M-547050-S	Nut, hex. lock M5x0.8
10. 24-089-03-S	Spring, choke return
11. 24-126-56-S	Bracket, control
12. M-645016-S	Screw, hex. flange M6x1.0x16 (4)
13. 12-237-01-S	Clamp, cable (2)
14. 24-086-43-S	Screw, hex. flange M5x0.8x16 (2)
15. 24-090-07-S	Lever, throttle actuator
16. X-20-1-S	Washer, lock 1/4"
17. M-541050-S	Nut, hex. flange M5x0.8
18. 24-468-01-S	Washer, plain 5.5 mm (3)
19. 24-089-45-S	Spring, governor
20. M-446030-S	Nut, hex M4x0.7
21. 24-090-13-S	Lever, throttle control
22. M-545020-S	Screw, hex. flange M5x0.8x20
23. 24-089-51-S	Spring, throttle limiter
24. 24-090-05-S	Lever, choke
25. 41-468-03-S	Washer, spring 1/4"
26. M-403025-S	Screw, hex. cap M4x0.7x25
27. 24-079-02-S	Linkage, choke

OIL PAN/LUBRICATION

KEY PART NO. NO.	DESCRIPTION
1. 24-199-07-S	Pan assembly, oil (Includes 2-11)
2. 24-393-37-S	Oil pump assembly (Includes 3,4)
3. 24-381-11-S	Tube, oil pickup
4. 24 153 01-S	O-Ring, oil pump
5. M-631005-S	Washer, plain 6 mm (2)
6. M-645025-S	Screw, hex. flange M6x1.0x25 (2)
7. 24-162-26-S	Screen, oil
8. 24-043-12-S	Kit, governor gear w/pin (Includes 9)
9. 12-380-01-S	Pin, governor regulating
10. 52-448-02-S	Tab, locking
11. 12-144-02-S	Shaft, governor gear
12. 24-153-08-S	O-Ring
13. 25-139-62-S	Plug, hex. ctsk. 3/8"
14. 24-136-01-S	Nipple, oil filter
15. 12-050-01-S	Filter, oil
16. 52-032-08-S	Seal, oil (PTO end)
17. 24-086-17-S	Screw, hex. flange M8x1.25x45
18. 24-086-16-S	Screw, hex. flange M8x1.25x45 (9)
19. 25-139-57-S	Plug, sq. hd. solid 3/8" N.P.T.F.

NOTE: All component dimensions given in U.S. inches
1 inch = 25.4 mm

REPAIR PARTS

TRACTOR - - MODEL NUMBER 944.603900

KOHLER ENGINE - MODEL NUMBER CV730, TYPE NUMBER 0017

CRANKSHAFT

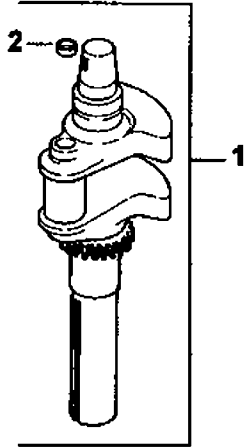

EXHAUST

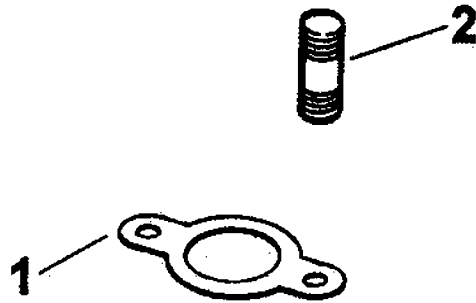

FUEL SYSTEM

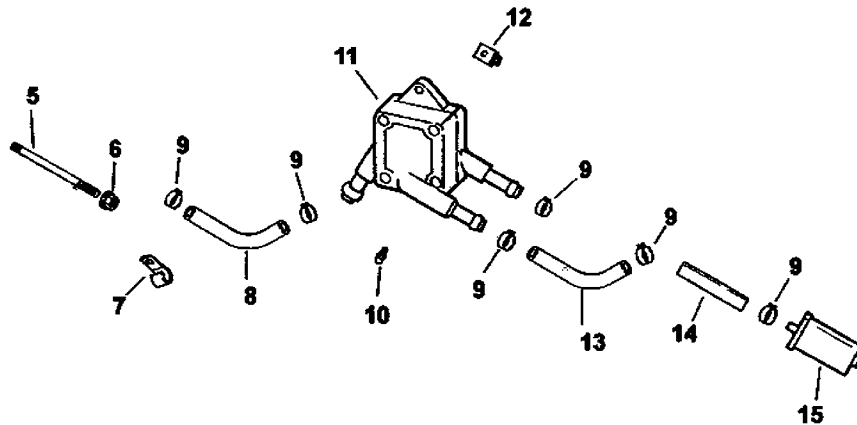
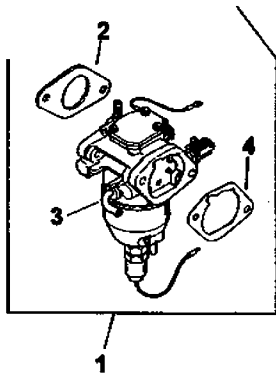

REPAIR PARTS

TRACTOR - - MODEL NUMBER 944.603900

KOHLER ENGINE - MODEL NUMBER CV730, TYPE NUMBER 0017

CRANKSHAFT

KEY PART NO. NO.	DESCRIPTION
1. 24-014-72-S	Crankshaft (Includes 2)
2. 52-139-09-S	Plug, cup

EXHAUST

KEY PART NO. NO.	DESCRIPTION
1. 24-041-02-S	Gasket, exhaust (2)
2. 25-072-04-S	Stud, M8x1.25x33 (4)

- 24 782 23
- 24 755 113-S

- Miniblock
- Gasket Set

FUEL SYSTEM

KEY PART NO. NO.	DESCRIPTION
1. 24-853-90-S	Kit, carburetor w/gaskets (Includes 2-4)
2. 24-041-52-S	Gasket, carburetor
3. 24-053-90	Carburetor assembly (For information only not available separately) (Service with 24 234 02-S & Kits 24 757 18-S, 24 757 19-S, 24 757 20-S, 24 757 21-S, & 24 757 22-S)
4. 24 041 14-S	Gasket, air cleaner base
5. M-629095-S	Stud, M6x1.0x95 (2)
6. M-641060-S	Nut, hex. flange M6x1.0 (2)
7. 25-353-03-S	Line, fuel 14"
8. 25-237-14-S	Clamp, hose (6)
9. 24-086-12-S	Screw, hex. cap. M6x1.7x18 (2)
10. 24-393-16-S	Pump, fuel - pulse
11. 24-100-01-S	Nut, plastic (2)
12. 24-353-03-S	Line, fuel 10-5/8"
13. 15-353-04-S	Line, fuel 11-1/2"
14. 24-050-02-S	Filter, fuel

NOT ILLUSTRATED

- 24 234 02-S Bowl, float
- 24 757 18-S Kit, overhaul
- 24 757 19-S Kit, choke repair
- 24 757 20-S Kit, gasket
- 24 757 21-S Kit, accelerator pump repair
- 24 757 22-S Kit, fuel shutdown solenoid

NOTE: All component dimensions given in U.S. inches
1 inch = 25.4 mm

SERVICE NOTES

SUGGESTED GUIDE FOR SIGHTING SLOPES FOR SAFE OPERATION

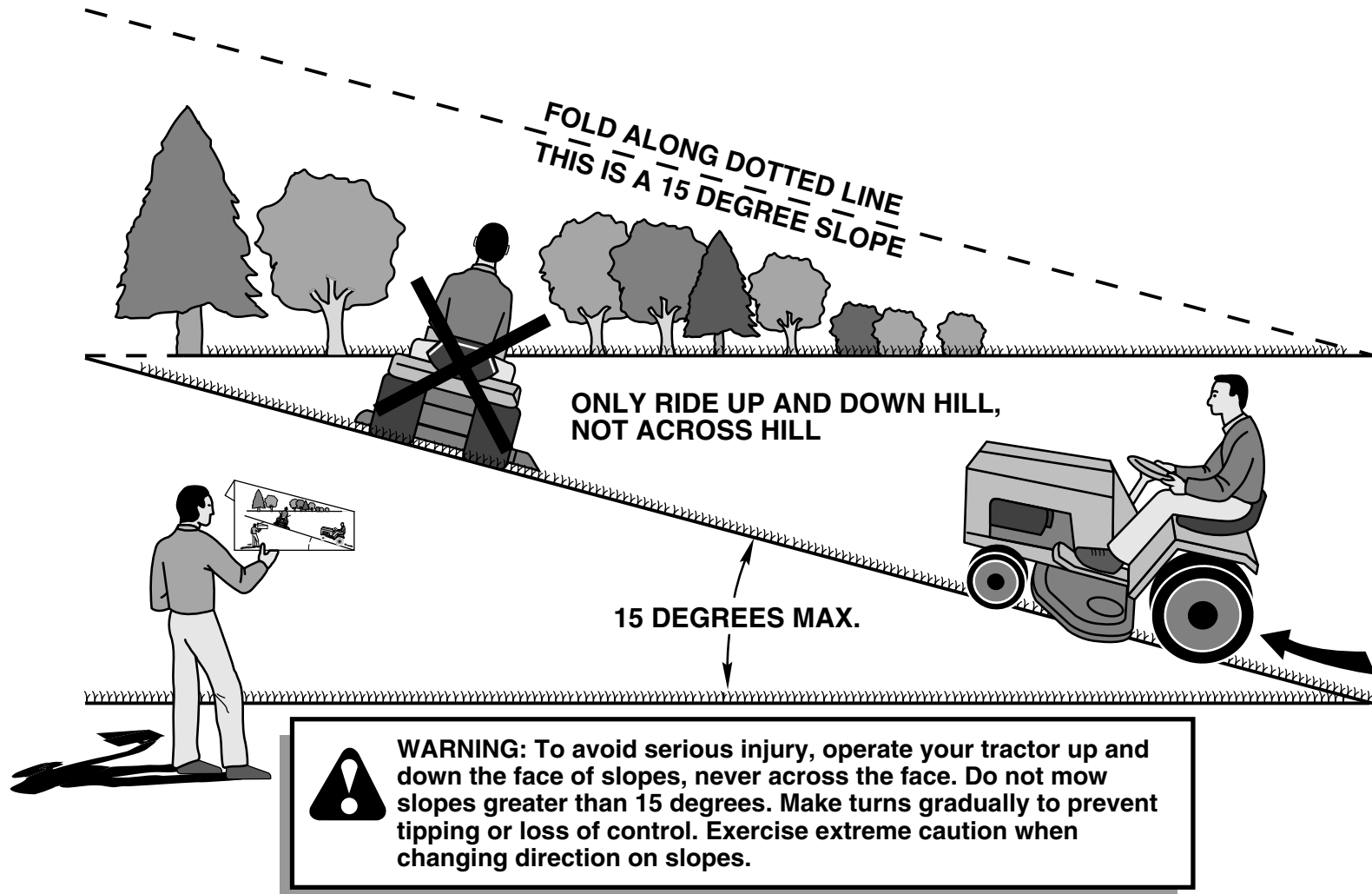

1. Fold this page along dotted line indicated above.
2. Hold page before you so that its left edge is vertically parallel to a tree trunk or other upright structure.
3. Sight across the fold in the direction of hill slope you want to measure.
4. Compare the angle of the fold with the slope of the hill.

Get it fixed, at your home or ours!

Just Call:

1-800-4-MY-HOME[®]

(1-800-469-4663)

24 hours a day, 7 days a week

For the repair of major brand appliances **in your own home...**
no matter who made it, no matter who sold it!

For your nearest **Sears Parts and Service** location,
to bring in products like vacuums, lawn equipment and electronics.

For **Sears Parts & Service**, to order the replacement parts,
accessories and owner's manuals that you need to do-it-yourself.

www.sears.ca

To purchase or inquire about a Sears Maintenance Agreement, call:

1-800-361-6665

9 a.m. – 11 p.m. Mon. – Fri., EST, 9 a.m. – 4 p.m. Sat.

Pour service en français:

1-800-LE-FOYER^{MC}

(1-800-533-6937)

www.sears.ca



® / TM Trademarks of Sears, Roebuck and Co. used under license by Sears Canada

MD Marque déposée / MC Marque de commerce de Sears, Roebuck and Co. utilisée en vertu d'une licence de Sears Canada