

# **SEARS**

**OWNER'S  
MANUAL**

**MODEL NO.  
944.604010**

**Important:  
Read and follow  
all Safety Rules  
and Instructions  
Before Operating  
This Equipment**

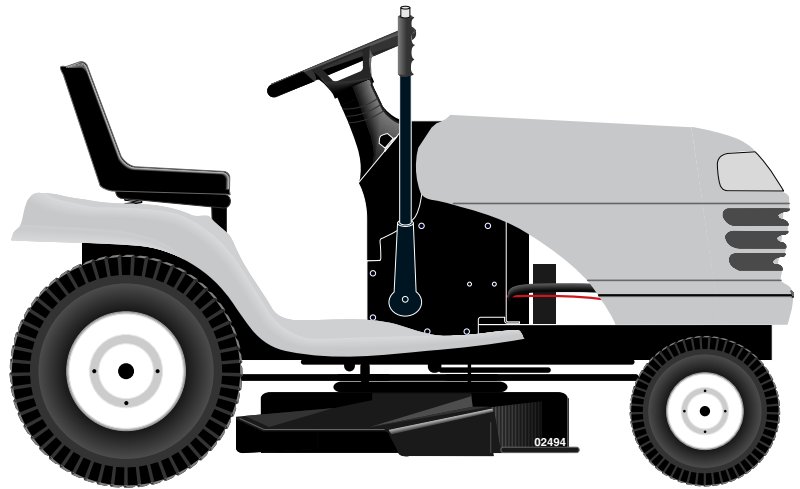

# **CRAFTSMAN®**

**22 HP  
ELECTRIC START  
42" MOWER  
6 SPEED TRANSAXLE  
LAWN TRACTOR**

- **Assembly**
- **Operation**
- **Maintenance**
- **Service and Adjustments**
- **Repair Parts**



# SAFETY RULES



## Safe Operation Practices for Ride-On Mowers

**IMPORTANT:** THIS CUTTING MACHINE IS CAPABLE OF AMPUTATING HANDS AND FEET AND THROWING OBJECTS. FAILURE TO OBSERVE THE FOLLOWING SAFETY INSTRUCTIONS COULD RESULT IN SERIOUS INJURY OR DEATH.

### I. GENERAL OPERATION

- Read, understand, and follow all instructions in the manual and on the machine before starting.
- Only allow responsible adults, who are familiar with the instructions, to operate the machine.
- Clear the area of objects such as rocks, toys, wire, etc., which could be picked up and thrown by the blade.
- Be sure the area is clear of other people before mowing. Stop machine if anyone enters the area.
- Never carry passengers.
- Do not mow in reverse unless absolutely necessary. Always look down and behind before and while backing.
- Be aware of the mower discharge direction and do not point it at anyone. Do not operate the mower without either the entire grass catcher or the guard in place.
- Slow down before turning.
- Never leave a running machine unattended. Always turn off blades, set parking brake, stop engine, and remove keys before dismounting.
- Turn off blades when not mowing.
- Stop engine before removing grass catcher or unclogging chute.
- Mow only in daylight or good artificial light.
- Do not operate the machine while under the influence of alcohol or drugs.
- Watch for traffic when operating near or crossing roadways.
- Use extra care when loading or unloading the machine into a trailer or truck.
- Data indicates that operators, age 60 years and above, are involved in a large percentage of riding mower-related injuries. These operators should evaluate their ability to operate the riding mower safely enough to protect themselves and others from serious injury.
- Keep machine free of grass, leaves or other debris build-up which can touch hot exhaust/engine parts and burn. Do not allow the mower deck to plow leaves or other debris which can cause build-up to occur. Clean any oil or fuel spillage before operating or storing the machine. Allow machine to cool before storage.

### II. SLOPE OPERATION

Slopes are a major factor related to loss-of-control and tipover accidents, which can result in severe injury or death. All slopes require extra caution. If you cannot back up the slope or if you feel uneasy on it, do not mow it.

#### DO:

- Mow up and down slopes, not across.
- Remove obstacles such as rocks, tree limbs, etc.
- Watch for holes, ruts, or bumps. Uneven terrain could overturn the machine. *Tall grass can hide obstacles.*
- Use slow speed. Choose a low gear so that you will not have to stop or shift while on the slope.
- Follow the manufacturer's recommendations for wheel weights or counterweights to improve stability.
- Use extra care with grass catchers or other attachments. These can change the stability of the machine.
- Keep all movement on the slopes *slow* and *gradual*. Do not make sudden changes in speed or direction.

- Avoid starting or stopping on a slope. If tires lose traction, disengage the blades and proceed slowly *straight* down the slope.

#### DO NOT:

- *Do not* turn on slopes unless necessary, and then, turn slowly and gradually downhill, if possible.
- *Do not* mow near drop-offs, ditches, or embankments. The mower could suddenly turn over if a wheel is over the edge of a cliff or ditch, or if an edge caves in.
- *Do not* mow on wet grass. Reduced traction could cause sliding.
- *Do not* try to stabilize the machine by putting your foot on the ground.
- *Do not* use grass catcher on steep slopes.

### III. CHILDREN

Tragic accidents can occur if the operator is not alert to the presence of children. Children are often attracted to the machine and the mowing activity. *Never* assume that children will remain where you last saw them.

- Keep children out of the mowing area and under the watchful care of another responsible adult.
- Be alert and turn machine off if children enter the area.
- Before and when backing, look behind and *down* for small children.
- Never carry children. They may fall off and be seriously injured or interfere with safe machine operation.
- Never allow children to operate the machine.
- Use extra care when approaching blind corners, shrubs, trees, or other objects that may obscure vision.

### IV. SERVICE

- Use extra care in handling gasoline and other fuels. They are flammable and vapors are explosive.
  - Use only an approved container.
  - Never remove gas cap or add fuel with the engine running. Allow engine to cool before refueling. Do not smoke.
  - Never refuel the machine indoors.
  - Never store the machine or fuel container inside where there is an open flame, such as a water heater.
- Never run a machine inside a closed area.
- Keep nuts and bolts, especially blade attachment bolts, tight and keep equipment in good condition.
- Never tamper with safety devices. Check their proper operation regularly.
- Keep machine free of grass, leaves, or other debris build-up. Clean oil or fuel spillage. Allow machine to cool before storing.
- Stop and inspect the equipment if you strike an object. Repair, if necessary, before restarting.
- Never make adjustments or repairs with the engine running.
- Grass catcher components are subject to wear, damage, and deterioration, which could expose moving parts or allow objects to be thrown. Frequently check components and replace with manufacturer's recommended parts, when necessary.
- Mower blades are sharp and can cut. Wrap the blade(s) or wear gloves, and use extra caution when servicing them.
- Check brake operation frequently. Adjust and service as required.



# SAFETY RULES



## Safe Operation Practices for Ride-On Mowers

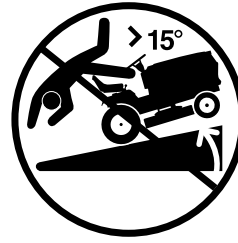

- Be sure the area is clear of other people before mowing. Stop machine if anyone enters the area.
- Never carry passengers or children even with the blades off.
- Do not mow in reverse unless absolutely necessary. Always look down and behind before and while backing.
- Never carry children. They may fall off and be seriously injured or interfere with safe machine operation.
- Keep children out of the mowing area and under the watchful care of another responsible adult.
- Be alert and turn machine off if children enter the area.
- Before and when backing, look behind and down for small children.
- Mow up and down slopes (15° Max), not across.
- Remove obstacles such as rocks, tree limbs, etc.
- Watch for holes, ruts, or bumps. Uneven terrain could overturn the machine. Tall grass can hide obstacles.
- Use slow speed. Choose a low gear so that you will not have to stop or shift while on the slope.
- Avoid starting or stopping on a slope. If tires lose traction, disengage the blades and proceed slowly straight down the slope.
- If machine stops while going uphill, disengage blades, shift into reverse and back down slowly.
- Do not turn on slopes unless necessary, and then, turn slowly and gradually downhill, if possible.



**WARNING:** Do not coast down a hill in neutral, you may lose control of the tractor.



**WARNING:** Tow only the attachments that are recommended by and comply with specifications of the manufacturer of your tractor. Use common sense when towing. Operate only at the lowest possible speed when on a slope. Too heavy of a load, while on a slope, is dangerous. Tires can lose traction with the ground and cause you to lose control of your tractor.



**WARNING:** In order to prevent accidental starting when setting up, transporting, adjusting or making repairs, always disconnect spark plug wire and place wire where it cannot contact spark plug.

## TABLE OF CONTENTS

SAFETY RULES .....	2-3
PRODUCT SPECIFICATIONS .....	4
CUSTOMER RESPONSIBILITIES .....	4
WARRANTY .....	4
ASSEMBLY .....	6-8
OPERATION .....	9-14
MAINTENANCE .....	15-18

MAINTENANCE SCHEDULE .....	15
SERVICE AND ADJUSTMENTS .....	19-23
STORAGE .....	24
TROUBLESHOOTING .....	25-26
REPAIR PARTS - TRACTOR .....	28-45
REPAIR PARTS - ENGINE .....	46-50
PARTS ORDERING/SERVICE .....	BACK COVER

## PRODUCT SPECIFICATIONS

Gasoline Capacity and type:	4 Gallons Unleaded Regular
Oil Type (API-SF-SJ):	SAE 30 (above 32°F) SAE 5W-30 (below 32°F) Synthetic (below 0°F)
Your tractor was shipped from the factory with non-synthetic SAE 10W-30 motor oil.	
Oil Capacity:	W/Filter: 4.0 Pints W/O Filter: 3.75 Pints
Spark Plug: (GAP: .040")	Champion QC12YC
Ground Speed (MPH):	Forward: 1st 1.2 2nd 1.5 3rd 2.4 4th 3.5 5th 4.8 6th 5.3 Reverse: 1.5
Tire Pressure:	Front: 14 PSI Rear: 10 PSI
Charging System:	3 Amps Battery 5 Amps Headlights
Battery:	AMP/HR: 35 Min. CCA: 280 Case Size: U1R
Blade Bolt Torque:	27-35 Ft. Lbs.

**CONGRATULATIONS** on your purchase of a new tractor. It has been designed, engineered and manufactured to give you the best possible dependability and performance.

Should you experience any problem you cannot easily remedy, please contact your nearest authorized service center/department. We have competent, well-trained technicians and the proper tools to service or repair this tractor.

Please read and retain this manual. The instructions will enable you to assemble and maintain your tractor properly. Always observe the "SAFETY RULES".

## MAINTENANCE AGREEMENT

A Maintenance Agreement is available on this product. Contact your nearest Sears store for details.

## CUSTOMER RESPONSIBILITIES

- Read and observe the safety rules.
- Follow a regular schedule in maintaining, caring for and using your tractor.
- Follow the instructions under "Maintenance" and "Storage" sections of this owner's manual.

**WARNING:** This tractor is equipped with an internal combustion engine and should not be used on or near any unimproved forest-covered, brush-covered or grass-covered land unless the engine's exhaust system is equipped with a spark arrester meeting applicable local or state laws (if any). If a spark arrester is used, it should be maintained in effective working order by the operator.

A spark arrester for the muffler is available through your nearest authorized service center/department (See REPAIR PARTS section of this manual).

# WARRANTY

### LIMITED TWO (2) YEAR WARRANTY ON CRAFTSMAN TRACTOR (RIDING EQUIPMENT)

For Two (2) years from date of purchase Sears Canada, Inc. will repair or replace at Sears option free of charge parts which are defective as a result of material or workmanship.

### FULL ONE (1) YEAR WARRANTY ON BATTERY

For One (1) year from date of purchase, if any battery included with this riding equipment proves defective in material or workmanship and our testing determines the battery will not hold a charge, Sears will replace the battery at no charge.

### COMMERCIAL OR RENTAL USE

Warranty on Riding Equipment used for commercial or rental purposes is limited to ninety (90) days.

### This Warranty does **NOT** cover:

1. Pre-delivery set-up.
2. Tire replacement or repair caused by punctures from outside objects (such as nails, thorns, stumps, or glass).
3. Expendable items which become worn during normal use, such as blades, spark plug, air cleaners and belts.
4. Repairs necessary because of operator abuse or negligence, including damaged jackshaft or mandrel and the failure to operate and maintain the equipment according to the instructions contained in the Owner's Manual.
5. In Home service.

Warranty service is available by returning the Craftsman Riding Equipment to the nearest Sears Service Centre/Department in Canada. This warranty applies only while this product is in use in Canada.

This warranty is in addition to any statutory warranty and does not exclude or limit legal rights you may have but shall run concurrently with applicable provincial legislation. Furthermore, some provinces do NOT allow limitation on how long an implied warranty will last so the above limitations may not apply to you.

**SEARS CANADA, INC., TORONTO, ONTARIO M5B 2B8**

# UNASSEMBLED PARTS

## Steering Wheel

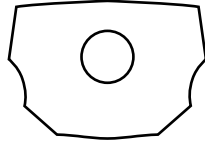
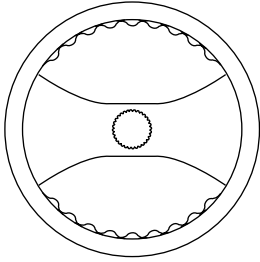

Steering Wheel Insert

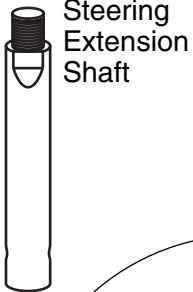

Steering Extension Shaft



Steering Wheel Adapter

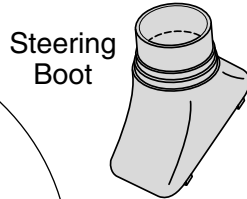

Steering Boot

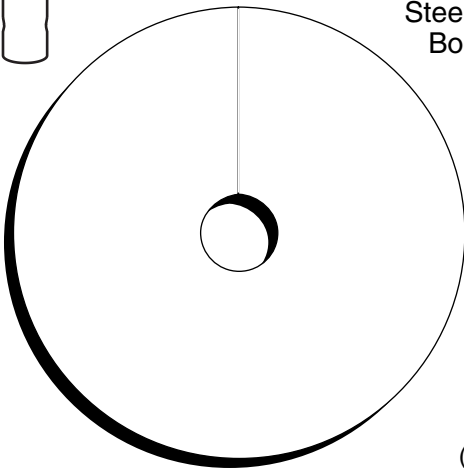

(1) Large Flat Washer

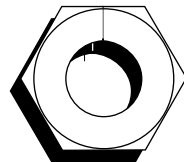

(1) Locknut 1/2-20

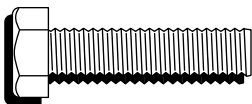

(1) Hex Bolt 1/4-28 x 1-1/4



(1) Locknut 1/4-28

## Battery



(2) Hex Bolts 1/4-20 x 3/4

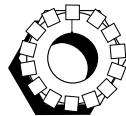

(2) Keps Nut 1/4-20

## Seat

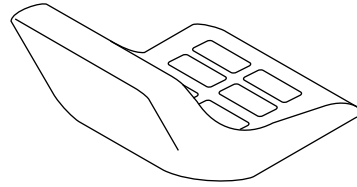

(1) Washer 17/32 x 1-3/16 x 12 Gauge



(1) Knob

## Gauge Wheels



(4) Adjusting Bar

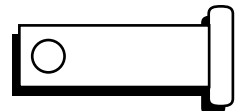

(4) Clevis Pins

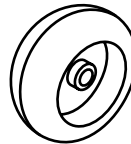

(4) Wheels

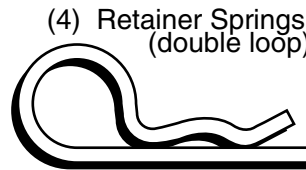

(4) Retainer Springs (double loop)

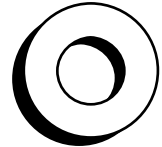

(4) Washers 3/8 x 3/4 x 14 Ga.

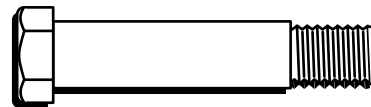

(4) Shoulder Bolt



(4) Locknut 3/8-16



(1) Oil Drain Tube For Future Use

## Slope Sheet

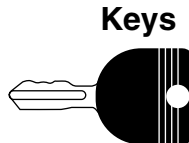

Keys

(2) Keys

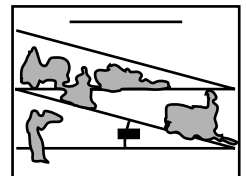

# ASSEMBLY

Your new tractor has been assembled at the factory with exception of those parts left unassembled for shipping purposes. To ensure safe and proper operation of your tractor all parts and hardware you assemble must be tightened securely. Use the correct tools as necessary to insure proper tightness.

## TOOLS REQUIRED FOR ASSEMBLY

A socket wrench set will make assembly easier. Standard wrench sizes are listed.

- |                    |                     |
|--------------------|---------------------|
| (1) 3/4" wrench    | Pliers              |
| (2) 7/16" wrenches | Tire pressure gauge |
| Utility knife      |                     |

When right or left hand is mentioned in this manual, it means when you are in the operating position (seated behind the steering wheel).

## TO REMOVE TRACTOR FROM CARTON

### UNPACK CARTON

- Remove all accessible loose parts and parts cartons from carton.
- Cut along dotted lines on all four panels of carton. Remove end panels and lay side panels flat.
- Check for any additional loose parts or cartons and remove.

## BEFORE REMOVING TRACTOR FROM SKID

### ATTACH STEERING WHEEL (See Fig. 1)

#### ASSEMBLE EXTENSION SHAFT AND BOOT

- Slide extension shaft onto lower steering shaft. Align mounting holes in extension and lower shafts and install 1/4 hex bolt and locknut. Tighten securely.

**IMPORTANT:** TIGHTEN BOLT AND NUT SECURELY TO 10-12 FT. LBS TORQUE.

- Place tabs of steering boot over tab slots in dash and push down to secure.

#### INSTALL STEERING WHEEL

- Position front wheels of the tractor so they are pointing straight forward.
- Remove steering wheel adapter from steering wheel and slide adapter onto steering shaft extension.
- Position steering wheel so cross bars are horizontal (left to right) and slide inside boot and onto adapter.
- Assemble large flat washer, 1/2 hex nut and tighten securely.
- Snap steering wheel insert into center of steering wheel.
- Remove protective materials from tractor hood and grill.

**IMPORTANT:** CHECK FOR AND REMOVE ANY STAPLES IN SKID THAT MAY PUNCTURE TIRES WHERE TRACTOR IS TO ROLL OFF SKID.

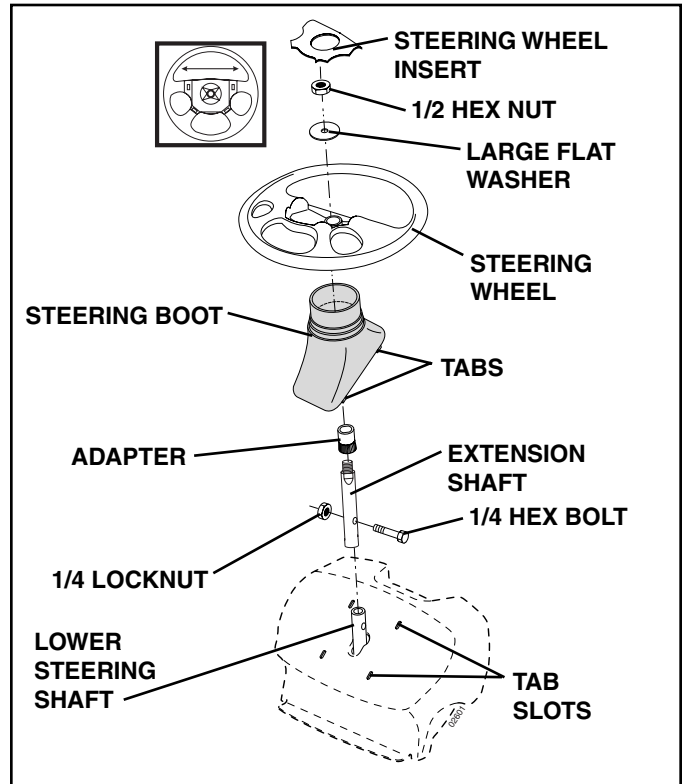

FIG. 1

## HOW TO SET UP YOUR TRACTOR

### CONNECT BATTERY (See Fig. 2)



**CAUTION:** Do not short battery terminals by allowing a wrench or any other object to contact both terminals at the same time. Before connecting battery, remove metal bracelets, wrist-watch bands, rings, etc.

**Positive terminal must be connected first to prevent sparking from accidental grounding.**

- Lift hood to raised position.
- Open terminal access doors, remove terminal protective caps and discard.
- If this battery is put into service after month and year indicated on label (label located between terminals) charge battery for minimum of one hour at 6-10 amps.
- First connect RED battery cable to positive (+) battery terminal with hex bolt and keps nut as shown. Tighten securely.
- Connect BLACK grounding cable to negative (-) battery terminal with remaining hex bolt and keps nut. Tighten securely.
- Close terminal access doors.

# ASSEMBLY

Use terminal access doors for:

- Inspection for secure connections (to tighten hardware).
- Inspection for corrosion.
- Testing battery.
- Jumping (if required).
- Periodic charging.

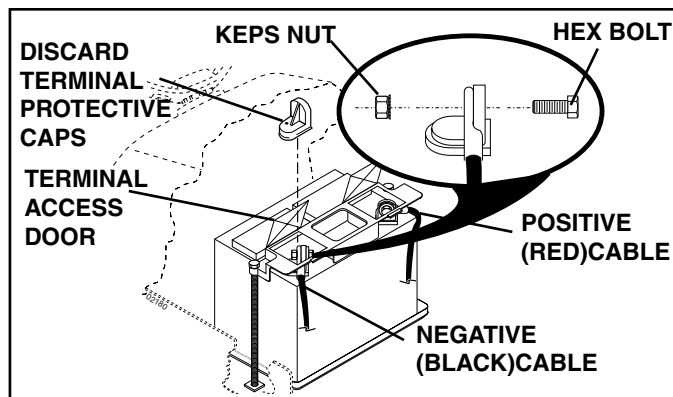

FIG. 2

## INSTALL SEAT (See Fig. 3)

Adjust seat before tightening adjustment knob.

- Remove adjustment knob and flat washer securing seat to cardboard packing and set aside for assembly of seat to tractor.
- Pivot seat upward and remove from the cardboard packing. Remove the cardboard packing and discard.
- Place seat on seat pan so head of shoulder bolt is positioned over large slotted hole in pan.
- Push down on seat to engage shoulder bolt in slot and pull seat towards rear of tractor.
- Pivot seat and pan forward and assemble adjustment knob and flat washer loosely. Do not tighten. Lower seat into operating position and sit on seat.
- Slide seat until a comfortable position is reached which allows you to press clutch/brake pedal all the way down.
- Get off seat without moving its adjusted position.
- Raise seat and tighten adjustment knob securely.

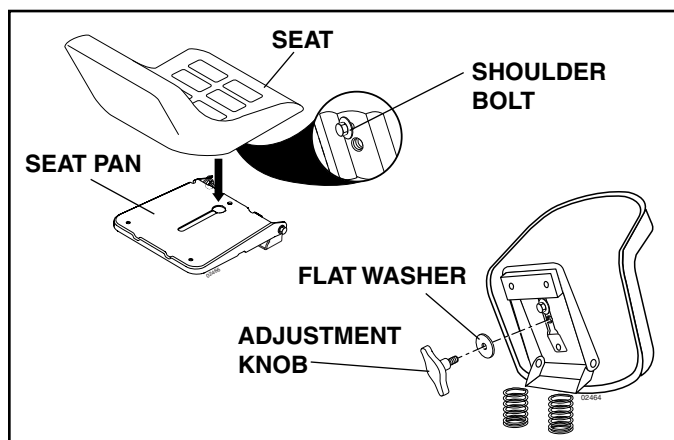

FIG. 3

**NOTE:** You may now roll or drive your tractor off the skid. Follow the appropriate instruction below to remove the tractor from the skid.

## TO ROLL TRACTOR OFF SKID(See Operation section for location and function of controls)

- Press lift lever plunger and raise attachment lift lever to its highest position.
- Release parking brake by depressing clutch/brake pedal.
- Place gearshift lever in neutral (N) position.
- Roll tractor forward off skid.
- Remove banding holding deflector shield up against tractor.

## TO DRIVE TRACTOR OFF SKID(See Operation section for location and function of controls)

**WARNING:** Before starting, read, understand and follow all instructions in the Operation section of this manual. Be sure tractor is in a well-ventilated area. Be sure the area in front of tractor is clear of other people and objects.

- Be sure all the above assembly steps have been completed.
- Check engine oil level and fill fuel tank with gasoline.
- Sit on seat in operating position, depress clutch/brake pedal and set the parking brake.
- Place gear shift lever in neutral (N) position.
- Press lift lever plunger and raise attachment lift lever to its highest position.
- Start the engine. After engine has started, move throttle control to idle position.
- Depress clutch/brake pedal into full "BRAKE" position and hold. Move gearshift lever to 1st gear.
- Slowly release clutch/brake pedal and slowly drive tractor off skid.
- Apply brake to stop tractor, set parking brake and place gearshift lever in neutral position.
- Turn ignition key to "OFF" position.

Continue with the instructions that follow.

## INSTALL MULCHER PLATE (If previously removed) (See Fig. 4A)

- Raise and hold deflector shield in upright position.
- Place front of mulcher plate over front of mower deck opening and slide into place, as shown.
- Hook front latch into hole on front of mower deck.
- Hook rear latch into hole on back of mower deck.



**CAUTION:** Do not remove deflector shield from mower.

# ASSEMBLY

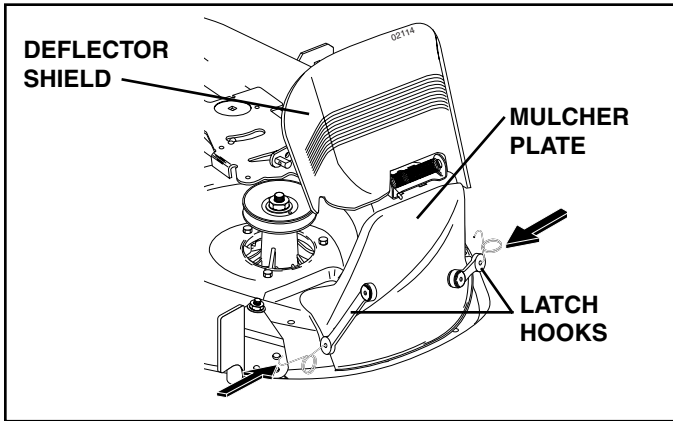

FIG. 4A

## TO CONVERT TO BAGGING OR DISCHARGING

Simply remove mulcher plate and store in a safe place. Your mower is now ready for discharging or installation of optional grass catcher accessory.

**NOTE:** It is not necessary to change blades. The mulcher blades are designed for discharging and bagging also.

## ASSEMBLE GAUGE WHEELS TO MOWER DECK (See Fig. 4B)

The gauge wheels are designed to keep the mower deck in proper position when operating mower. Be sure they are properly adjusted to ensure optimum mower performance.

- Slide gauge wheel bar down into bracket channel. Be sure that gauge wheel bar aligning holes are on top. Assemble gauge wheels as shown using shoulder bolts, 3/8 washers and 3/8-16 center locknuts and tighten securely.
- Adjust gauge wheels before operating mower. See "TO ADJUST GAUGE WHEELS" in the Operation section of this manual.

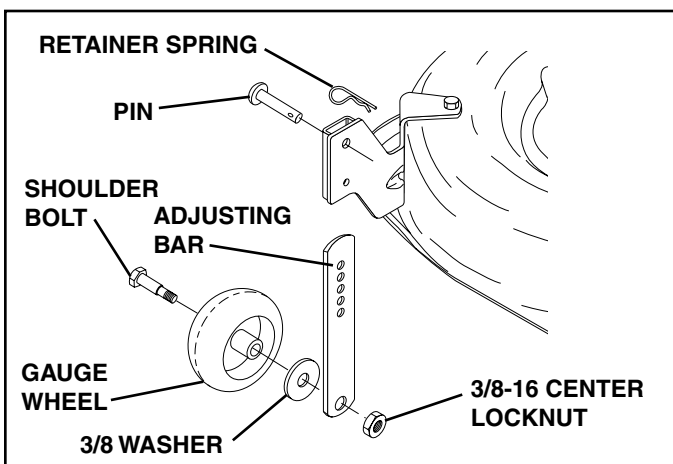

FIG. 4B

## CHECK TIRE PRESSURE

The tires on your tractor were overinflated at the factory for shipping purposes. Correct tire pressure is important for best cutting performance.

- Reduce tire pressure to PSI shown in "PRODUCT SPECIFICATIONS" section of this manual.

## CHECK DECK LEVELNESS

For best cutting results, mower housing should be properly leveled. See "TO LEVEL MOWER HOUSING" in the Service and Adjustments section of this manual.

## CHECK FOR PROPER POSITION OF ALL BELTS

See the figures that are shown for replacing motion and mower blade drive belts in the Service and Adjustments section of this manual. Verify that the belts are routed correctly.

## CHECK BRAKE SYSTEM

After you learn how to operate your tractor, check to see that the brake is properly adjusted. See "TO ADJUST BRAKE" in the Service and Adjustments section of this manual.

## ✓ CHECKLIST

*BEFORE YOU OPERATE AND ENJOY YOUR NEW TRACTOR, WE WISH TO ASSURE THAT YOU RECEIVE THE BEST PERFORMANCE AND SATISFACTION FROM THIS QUALITY PRODUCT.*

*PLEASE REVIEW THE FOLLOWING CHECKLIST:*

- ✓ All assembly instructions have been completed.
- ✓ No remaining loose parts in carton.
- ✓ Battery is properly prepared and charged. (Minimum 1 hour at 6 amps).
- ✓ Seat is adjusted comfortably and tightened securely.
- ✓ All tires are properly inflated. (For shipping purposes, the tires were overinflated at the factory).
- ✓ Be sure mower deck is properly leveled side-to-side/front-to-rear for best cutting results. (Tires must be properly inflated for leveling).
- ✓ Check mower and drive belts. Be sure they are routed properly around pulleys and inside all belt keepers.
- ✓ Check wiring. See that all connections are still secure and wires are properly clamped.

*WHILE LEARNING HOW TO USE YOUR TRACTOR, PAY EXTRA ATTENTION TO THE FOLLOWING IMPORTANT ITEMS:*

- ✓ Engine oil is at proper level.
- ✓ Fuel tank is filled with fresh, clean, regular unleaded gasoline.
- ✓ Become familiar with all controls - their location and function. Operate them before you start the engine.
- ✓ Be sure brake system is in safe operating condition.



# OPERATION

These symbols may appear on your product or in literature supplied with the product. Learn and understand their meaning.

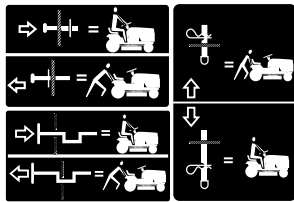
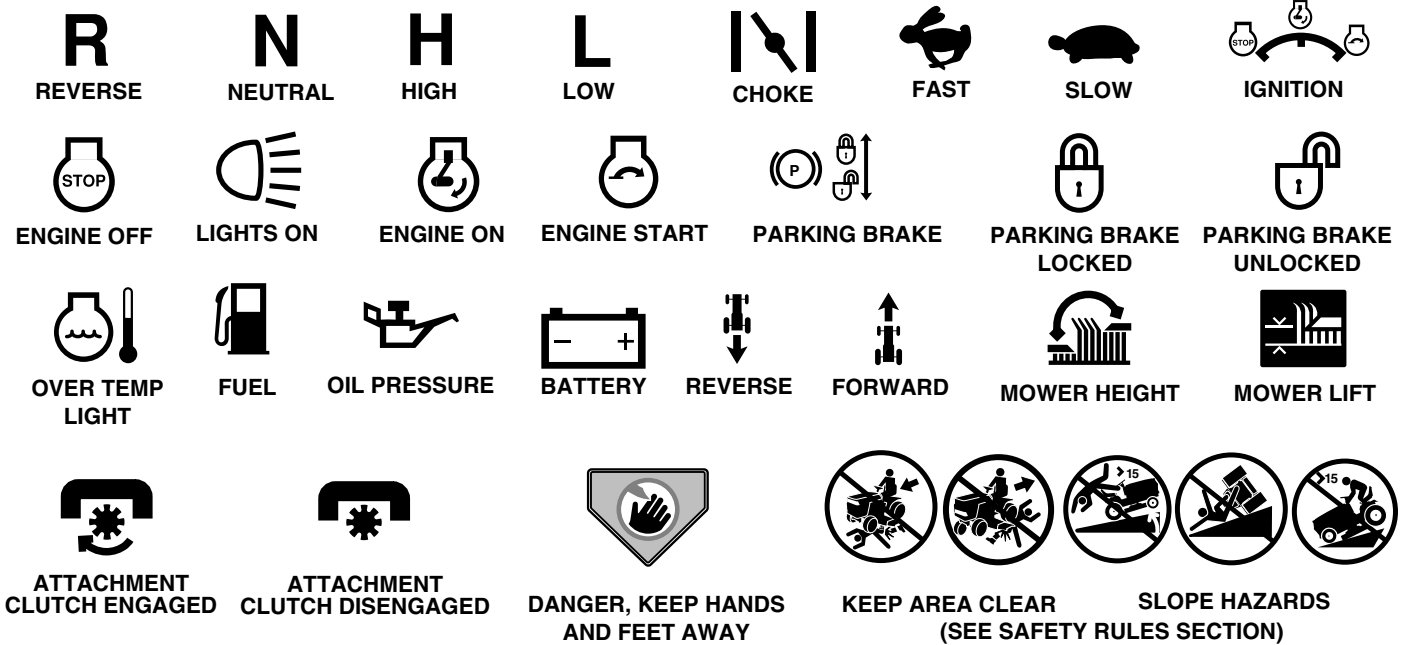

**FREE WHEEL**  
(Automatic Models only)



Failure to follow instructions could result in serious injury or death. The safety alert symbol is used to identify safety information about hazards which can result in death, serious injury and/or property damage.



**DANGER** indicates a hazard which, if not avoided, will result in death or serious injury.



**WARNING** indicates a hazard which, if not avoided, could result in death or serious injury.



**CAUTION** indicates a hazard which, if not avoided, might result in minor or moderate injury.

**CAUTION** when used **without** the alert symbol, indicates a situation that **could result in damage to the tractor and/or engine.**



**HOT SURFACES** indicates a hazard which, if not avoided, could result in death, serious injury and/or property damage.



**FIRE** indicates a hazard which, if not avoided, could result in death, serious injury and/or property damage.

# OPERATION

## KNOW YOUR TRACTOR

### READ THIS OWNER'S MANUAL AND SAFETY RULES BEFORE OPERATING YOUR TRACTOR

Compare the illustrations with your tractor to familiarize yourself with the locations of various controls and adjustments. Save this manual for future reference.

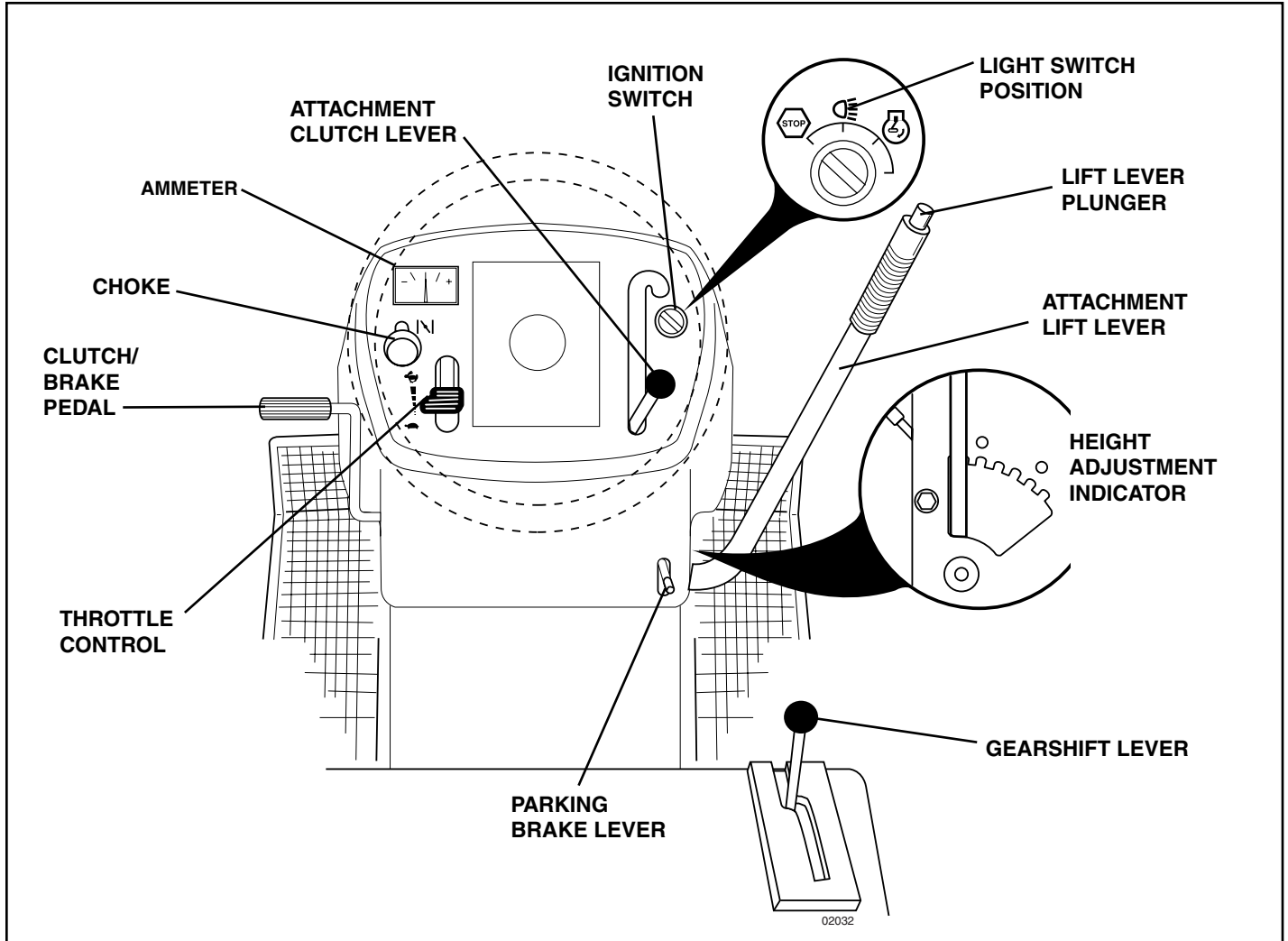

FIG. 5

Our tractors conform to the safety standards of the American National Standards Institute.

**THROTTLE CONTROL:** Used for starting and controlling engine speed.

**CHOKE CONTROL:** Used for starting a cold engine.

**CLUTCH/BRAKE PEDAL:** Used for clutching and braking the tractor and starting the engine.

**IGNITION SWITCH:** Used for starting and stopping the engine.

**LIGHT SWITCH POSITION:** Turns the headlights on and off.

**AMMETER:** Indicates charging (+) or discharging (-) of battery.

**ATTACHMENT CLUTCH LEVER:** Used to engage the mower blades, or other attachments mounted to your tractor.

**LIFT LEVER PLUNGER:** Used to release attachment lift lever when changing its position.

**ATTACHMENT LIFT LEVER:** Used to raise and lower the mower deck or other attachments mounted to your tractor.

**PARKING BRAKE LEVER:** Locks Clutch/Brake Pedal into the brake position.

**GEARSHIFT LEVER:** Selects the speed and direction of tractor.

# OPERATION



The operation of any tractor can result in foreign objects thrown into the eyes, which can result in severe eye damage. Always wear safety glasses or eye shields while operating your tractor or performing any adjustments or repairs. We recommend a wide vision safety mask over spectacles or standard safety glasses.

## HOW TO USE YOUR TRACTOR

### TO SET PARKING BRAKE (See Fig. 6)

Your tractor is equipped with an operator presence sensing switch. When engine is running, any attempt by the operator to leave the seat without first setting the parking brake will shut off the engine.

- Depress clutch/brake pedal into full "BRAKE" position and hold.
- Place parking brake lever in "ENGAGED" position and release pressure from clutch/brake pedal. Pedal should remain in "BRAKE" position. Make sure parking brake will hold tractor secure.

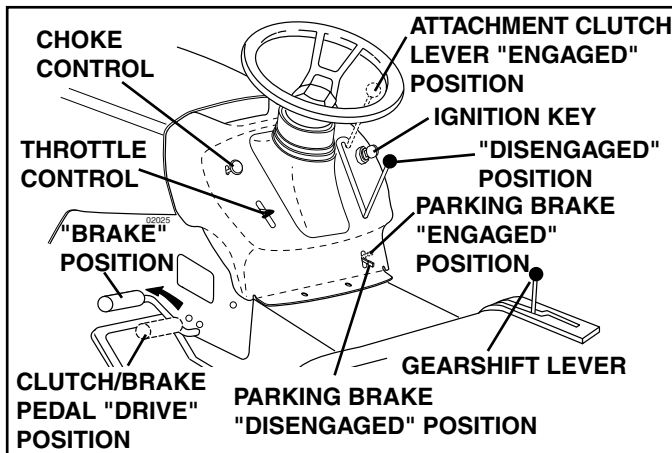

FIG. 6

### STOPPING (See Fig. 6)

#### MOWER BLADES -

- To stop mower blades, move attachment clutch lever to "DISENGAGED" position.

#### GROUND DRIVE -

- To stop ground drive, depress clutch/brake pedal into full "BRAKE" position.
- Move gearshift lever to neutral (N) position.

#### ENGINE -

- Move throttle control to slow position.

**NOTE:** Failure to move throttle control to slow position and allowing engine to idle before stopping may cause engine to "backfire".

- Turn ignition key to "OFF" position and remove key. Always remove key when leaving tractor to prevent unauthorized use.
- Never use choke to stop engine.

**IMPORTANT:** LEAVING THE IGNITION SWITCH IN ANY POSITION OTHER THAN "OFF" WILL CAUSE THE BATTERY TO BE DISCHARGED, (DEAD).

**NOTE:** Under certain conditions when tractor is standing idle with the engine running, hot engine exhaust gases may cause "browning" of grass. To eliminate this possibility, always stop engine when stopping tractor on grass areas.



**CAUTION:** Always stop tractor completely, as described above, before leaving the operator's position; to empty grass catcher, etc.

### TO USE THROTTLE CONTROL (See Fig. 6)

Always operate engine at full throttle.

- Operating engine at less than full throttle reduces the battery charging rate.
- Full throttle offers the best bagging and mower performance.

### TO USE CHOKE CONTROL (See Fig. 6)

Use choke control whenever you are starting a cold engine. Do not use to start a warm engine.

- To engage choke control, pull knob out. Slowly push knob in to disengage.

### TO MOVE FORWARD AND BACKWARD (See Fig. 6)

The direction and speed of movement is controlled by the gearshift lever.

- Start tractor with clutch/brake pedal depressed and gearshift lever in neutral (N) position.
- Move gearshift lever to desired position.
- Slowly release clutch/brake pedal to start movement.

**IMPORTANT:** BRING TRACTOR TO A COMPLETE STOP BEFORE SHIFTING OR CHANGING GEARS. FAILURE TO DO SO WILL SHORTEN THE USEFUL LIFE OF YOUR TRANSAXLE.

### TO ADJUST MOWER CUTTING HEIGHT (See Fig. 6)

The position of the attachment lift lever determines the cutting height.

- Grasp lift lever.
- Press plunger with thumb and move lever to desired position.

The cutting height range is approximately 1-1/2 to 4". The heights are measured from the ground to the blade tip with the engine not running. These heights are approximate and may vary depending upon soil conditions, height of grass and types of grass being mowed.

- The average lawn should be cut to approximately 2-1/2 inches during the cool season and to over 3 inches during hot months. For healthier and better looking lawns, mow often and after moderate growth.

# OPERATION

- For best cutting performance, grass over 6 inches in height should be mowed twice. Make the first cut relatively high; the second to desired height.

## TO ADJUST GAUGE WHEELS (See Fig. 6B)

Gauge wheels are properly adjusted when they are slightly off the ground when mower is at the desired cutting height in operating position. Gauge wheels then keep the deck in proper position to help prevent scalping in most terrain conditions.

**NOTE:** Adjust gauge wheels with tractor on a flat level surface.

- Adjust mower to desired cutting height (See "TO ADJUST MOWER CUTTING HEIGHT" in the Operation section of this manual).
- Remove retainer spring and clevis pin which secure each gauge wheel bar.
- Lower gauge wheels to ground. Raise gauge wheels slightly to align holes in bracket and gauge wheel bar and insert clevis pin. Gauge wheels should be slightly off the ground.
- Replace retainer spring into clevis pin.
- Be sure all gauge wheels are in the same setting.

**IMPORTANT:** BE SURE TO READJUST GAUGE WHEELS IF YOU CHANGE THE CUTTING HEIGHT OF THE MOWER DECK.

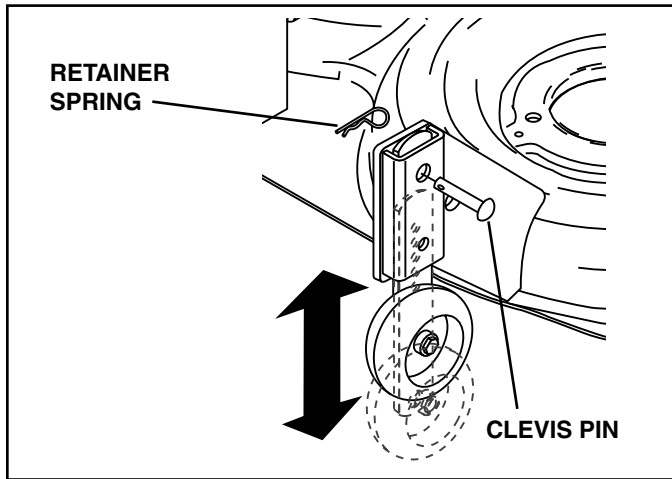

FIG. 6B

## TO OPERATE MOWER (See Fig. 7)

Your tractor is equipped with an operator presence sensing switch. Any attempt by the operator to leave the seat with the engine running and the attachment clutch engaged will shut off the engine. You must remain fully and centrally positioned in the seat to prevent the engine from hesitating or cutting off when operating your equipment on rough, rolling terrain or hills.

- Select desired height of cut.
- Start mower blades by engaging attachment clutch control.
- TO STOP MOWER BLADES - disengage attachment clutch control.



**CAUTION:** Do not operate the mower without either the entire grass catcher, on mowers so equipped, or the deflector shield in place.

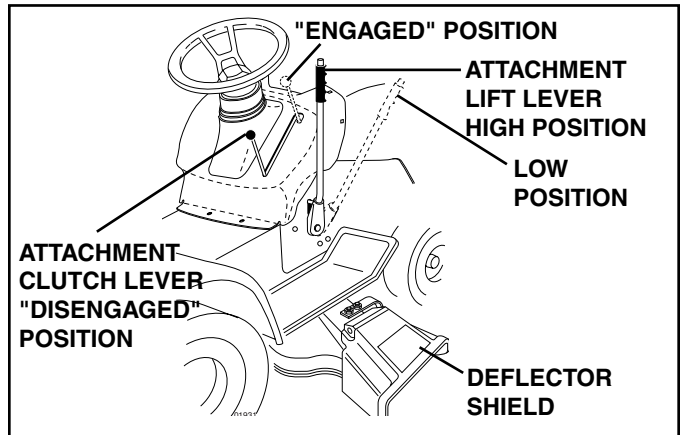

FIG. 7

## TO OPERATE ON HILLS



**WARNING:** Do not drive up or down hills with slopes greater than 15° and do not drive across any slope.

- Choose the slowest speed before starting up or down hills.
- Avoid stopping or changing speed on hills.
- If slowing is necessary, move throttle control lever to slower position.
- If stopping is absolutely necessary, push clutch/brake pedal quickly to brake position and engage parking brake.
- Move gearshift lever to 1st gear. Be sure you have allowed room for tractor to roll slightly as you restart movement.
- To restart movement, slowly release parking brake and clutch/brake pedal.
- Make all turns slowly.

## TO TRANSPORT

- Raise attachment lift to highest position with attachment lift control.
- When pushing or towing your tractor, be sure gearshift lever is in neutral (N) position.
- Do not push or tow tractor at more than five (5) MPH.

**NOTE:** To protect hood from damage when transporting your tractor on a truck or a trailer, be sure hood is closed and secured to tractor. Use an appropriate means of tying hood to tractor (rope, cord, etc.).

# OPERATION

## TOWING CARTS AND OTHER ATTACHMENTS

Tow only the attachments that are recommended by and comply with specifications of the manufacturer of your tractor. Use common sense when towing. Too heavy of a load, while on a slope, is dangerous. Tires can lose traction with the ground and cause you to lose control of your tractor.

## BEFORE STARTING THE ENGINE

### CHECK ENGINE OIL LEVEL

The engine in your tractor has been shipped, from the factory, already filled with summer weight oil.

- Check engine oil with tractor on level ground.
- Remove oil fill cap/dipstick and wipe clean, reinsert the dipstick and screw cap tight, wait for a few seconds, remove and read oil level. If necessary, add oil until "FULL" mark on dipstick is reached. Do not overfill.
- For cold weather operation you should change oil for easier starting (See "OIL VISCOSITY CHART" in the Maintenance section of this manual).
- To change engine oil, see the Maintenance section in this manual.

### ADD GASOLINE

- Fill fuel tank to bottom of filler neck. Do not overfill. Use fresh, clean, regular unleaded gasoline with a minimum of 87 octane. (Use of leaded gasoline will increase carbon and lead oxide deposits and reduce valve life). Do not mix oil with gasoline. Purchase fuel in quantities that can be used within 30 days to assure fuel freshness.



**CAUTION: Wipe off any spilled oil or fuel. Do not store, spill or use gasoline near an open flame.**

**IMPORTANT:** WHEN OPERATING IN TEMPERATURES BELOW 32°F (0°C), USE FRESH, CLEAN WINTER GRADE GASOLINE TO HELP INSURE GOOD COLD WEATHER STARTING.

**CAUTION: Alcohol blended fuels (called gasohol or using ethanol or methanol) can attract moisture which leads to separation and formation of acids during storage. Acidic gas can damage the fuel system of an engine while in storage. To avoid engine problems, the fuel system should be emptied before storage of 30 days or longer. Drain the gas tank, start the engine and let it run until the fuel lines and carburetor are empty. Use fresh fuel next season. See Storage Instructions for additional information. Never use engine or carburetor cleaner products in the fuel tank or permanent damage may occur.**

## TO START ENGINE (See Fig. 6)

When starting the engine for the first time or if the engine has run out of fuel, it will take extra cranking time to move fuel from the tank to the engine.

- Sit on seat in operating position, depress clutch/brake pedal and set parking brake.
- Place gear shift lever in neutral (N) position.
- Move attachment clutch to "DISENGAGED" position.
- Move throttle control to fast position
- Pull choke control out for a cold engine start attempt. For a warm engine start attempt the choke control may not be needed.

**NOTE:** Before starting, read the warm and cold starting procedures below.

- Insert key into ignition and turn key clockwise to "START" position and release key as soon as engine starts. Do not run starter continuously for more than fifteen seconds per minute. If the engine does not start after several attempts, push choke control in, wait a few minutes and try again. If engine still does not start, pull the choke control out and retry.

### WARM WEATHER STARTING (50° F and above)

- When engine starts, slowly push choke control in until the engine begins to run smoothly. If the engine starts to run roughly, pull the choke control out slightly for a few seconds and then continue to push the control in slowly.
- The attachments and ground drive can now be used. If the engine does not accept the load, restart the engine and allow it to warm up for one minute using the choke as described above.

### COLD WEATHER STARTING (50° F and below)

- When engine starts, slowly push choke control in until the engine begins to run smoothly. Continue to push the choke control in small steps allowing the engine to accept small changes in speed and load, until the choke control is fully in. If the engine starts to run roughly, pull the choke control out slightly for a few seconds and then continue to push the control in slowly. This may require an engine warm-up period from several seconds to several minutes, depending on the temperature.
- The attachments can be used during the engine warm-up period and may require the choke control be pulled out slightly.

**NOTE:** If at a high altitude (above 3000 feet) or in cold temperatures (below 32 F) the carburetor fuel mixture may need to be adjusted for best engine performance. See "TO ADJUST CARBURETOR" in the Service and Adjustments section of this manual.

# OPERATION

## MOWING TIPS

- Mower should be properly leveled for best mowing performance. See "TO LEVEL MOWER HOUSING" in the Service and Adjustments section of this manual.
- The left hand side of mower should be used for trimming.
- Drive so that clippings are discharged onto the area that has been cut. Have the cut area to the right of the machine. This will result in a more even distribution of clippings and more uniform cutting.
- When mowing large areas, start by turning to the right so that clippings will discharge away from shrubs, fences, driveways, etc. After one or two rounds, mow in the opposite direction making left hand turns until finished (See Fig. 8).

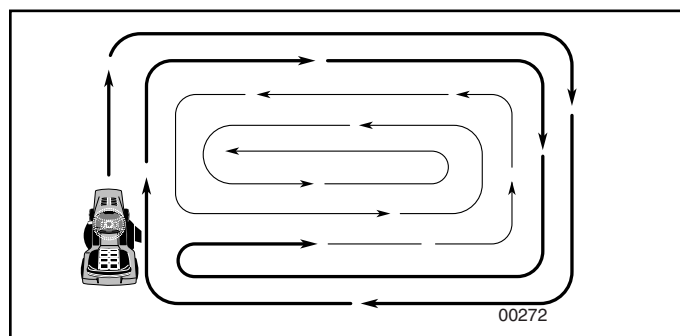

FIG. 8

- If grass is extremely tall, it should be mowed twice to reduce load and possible fire hazard from dried clippings. Make first cut relatively high; the second to the desired height.
- Do not mow grass when it is wet. Wet grass will plug mower and leave undesirable clumps. Allow grass to dry before mowing.
- **Always operate engine at full throttle when mowing** to assure better mowing performance and proper discharge of material. Regulate ground speed by selecting a low enough gear to give the mower cutting performance as well as the quality of cut desired.
- When operating attachments, select a ground speed that will suit the terrain and give best performance of the attachment being used.

## MULCHING MOWING TIPS

**IMPORTANT:** FOR BEST PERFORMANCE, KEEP MOWER HOUSING FREE OF BUILT-UP GRASS AND TRASH. CLEAN AFTER EACH USE.

- The special mulching blade will recut the grass clippings many times and reduce them in size so that as they fall onto the lawn they will disperse into the grass and not be noticed. Also, the mulched grass will biodegrade quickly to provide nutrients for the lawn. Always mulch with your highest engine (blade) speed as this will provide the best recutting action of the blades.
- Avoid cutting your lawn when it is wet. Wet grass tends to form clumps and interferes with the mulching action. The best time to mow your lawn is the early afternoon. At this time the grass has dried the newly cut area will not be exposed to direct sun light.
- For best results, adjust the mower cutting height so that the mower cuts off only the top one-third of the grass blades (See Fig. 9). For extremely heavy mulching, reduce your width of cut on each pass and mow slowly.

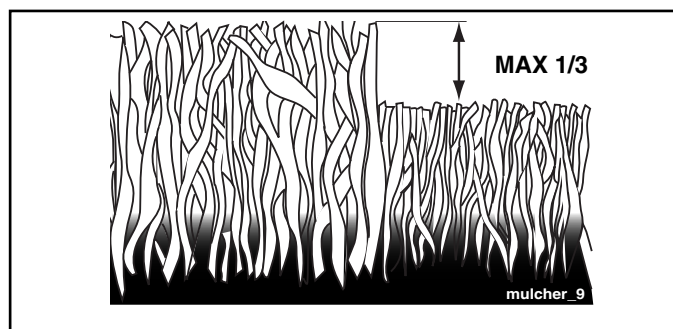

FIG. 9

- Certain types of grass and grass conditions may require that an area be mulched a second time to completely hide the clippings. When doing a second cut, mow across (perpendicular) to the first cut path.
- Change your cutting pattern from week to week. Mow north to south one week then change to east to west the next week. This will help prevent matting and graining of the lawn.

# MAINTENANCE

MAINTENANCE SCHEDULE		SERVICE DATES								
		BEFORE EACH USE	EVERY 8 HOURS	EVERY 25 HOURS	EVERY 50 HOURS	EVERY 100 HOURS	EVERY SEASON	BEFORE STORAGE		
TRACTOR	Check Brake Operation	✓	✓							
	Check Tire Pressure	✓	✓							
	Check Operator Presence and Interlock Systems	✓								
	Check for Loose Fasteners	✓				✓ <sub>5</sub>	✓			
	Sharpen/Replace Mower Blades			✓ <sub>3</sub>						
	Lubrication Chart			✓			✓			
	Check Battery Level			✓ <sub>4</sub>						
	Clean Battery and Terminals			✓			✓			
	Check Transaxle Cooling			✓						
	Check V-Belts					✓				
ENGINE	Check Engine Oil Level	✓	✓							
	Change Engine Oil (with oil filter)				✓ <sub>1,2</sub>		✓			
	Change Engine Oil (without oil filter)			✓ <sub>1,2</sub>			✓			
	Clean Air Filter			✓ <sub>2</sub>						
	Clean Air Screen			✓ <sub>2</sub>						
	Inspect Muffler/Spark Arrester				✓					
	Replace Oil Filter (If equipped)					✓ <sub>1,2</sub>				
	Clean Engine Cooling Fins					✓ <sub>2</sub>				
	Replace Spark Plug					✓	✓			
	Replace Air Filter Paper Cartridge					✓ <sub>2</sub>				
	Replace Fuel Filter						✓			

1 - Change more often when operating under a heavy load or in high ambient temperatures.  
 2 - Service more often when operating in dirty or dusty conditions.

3 - Replace blades more often when mowing in sandy soil.  
 4 - Not required if equipped with maintenance-free battery.  
 5 - Tighten front axle pivot bolt to 35 ft.-lbs. maximum. Do not overtighten.

maint\_sch-tractor.new.1

## GENERAL RECOMMENDATIONS

The warranty on this tractor does not cover items that have been subjected to operator abuse or negligence. To receive full value from the warranty, operator must maintain tractor as instructed in this manual.

Some adjustments will need to be made periodically to properly maintain your tractor.

At least once a season, check to see if you should make any of the adjustments described in the Service and Adjustments section of this manual.

- At least once a year you should replace the spark plug, clean or replace air filter, and check blades and belts for wear. A new spark plug and clean air filter assure proper air-fuel mixture and help your engine run better and last longer.

## BEFORE EACH USE

- Check engine oil level.
- Check brake operation.
- Check tire pressure.
- Check operator presence and interlock systems for proper operation.
- Check for loose fasteners.

## LUBRICATION CHART

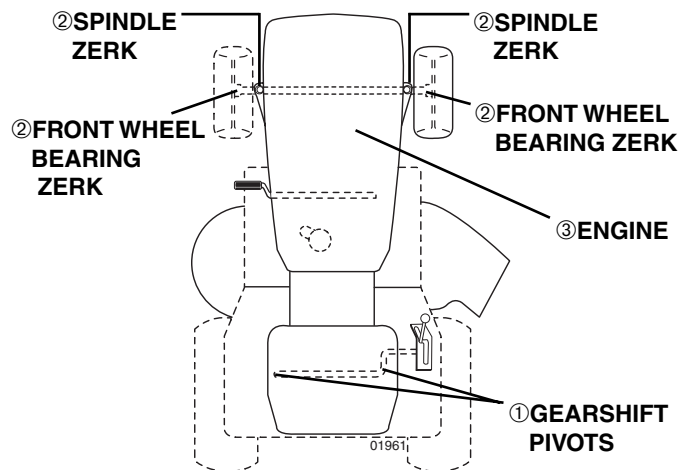

- ① SAE 30 OR 10W30 MOTOR OIL
- ② GENERAL PURPOSE GREASE
- ③ REFER TO MAINTENANCE "ENGINE" SECTION

**IMPORTANT:** DO NOT OIL OR GREASE THE PIVOT POINTS WHICH HAVE SPECIAL NYLON BEARINGS. VISCOUS LUBRICANTS WILL ATTRACT DUST AND DIRT THAT WILL SHORTEN THE LIFE OF THE SELF-LUBRICATING BEARINGS. IF YOU FEEL THEY MUST BE LUBRICATED, USE ONLY A DRY, POWDERED GRAPHITE TYPE LUBRICANT SPARINGLY.

# MAINTENANCE

## TRACTOR

Always observe safety rules when performing any maintenance.

## BRAKE OPERATION

If tractor requires more than six (6) feet stopping distance at high speed in highest gear, then brake must be adjusted. (See "TO ADJUST BRAKE" in the Service and Adjustments section of this manual).

## TIRES

- Maintain proper air pressure in all tires (See "PRODUCT SPECIFICATIONS" section of this manual).
- Keep tires free of gasoline, oil, or insect control chemicals which can harm rubber.
- Avoid stumps, stones, deep ruts, sharp objects and other hazards that may cause tire damage.

**NOTE:** To seal tire punctures and prevent flat tires due to slow leaks, tire sealant may be purchased from your local parts dealer. Tire sealant also prevents tire dry rot and corrosion.

## OPERATOR PRESENCE SYSTEM

Be sure operator presence and interlock systems are working properly. If your tractor does not function as described, repair the problem immediately.

- The engine should not start unless the brake pedal is fully depressed and attachment clutch control is in the disengaged position.
- When the engine is running, any attempt by the operator to leave the seat without first setting the parking brake should shut off the engine.
- When the engine is running and the attachment clutch is engaged, any attempt by the operator to leave the seat should shut off the engine.
- The attachment clutch should never operate unless the operator is in the seat.

## BLADE CARE

For best results mower blades must be kept sharp. Replace bent or damaged blades.

## BLADE REMOVAL (See Fig. 10)

- Raise mower to highest position to allow access to blades.
- Remove blade bolt, lock washer and flat washer securing blade.
- Install new or resharpened blade with trailing edge up towards deck as shown.

**IMPORTANT:** TO ENSURE PROPER ASSEMBLY, CENTER HOLE IN BLADE MUST ALIGN WITH STAR ON MANDREL ASSEMBLY.

- Reassemble blade bolt, lock washer and flat washer in exact order as shown.
- Tighten blade bolt securely (27-35 Ft. Lbs. torque).

**IMPORTANT:** BLADE BOLT IS HEAT TREATED. IF BOLT NEEDS REPLACING, REPLACE ONLY WITH APPROVE BOLT SHOWN IN THE REPAIR PARTS.

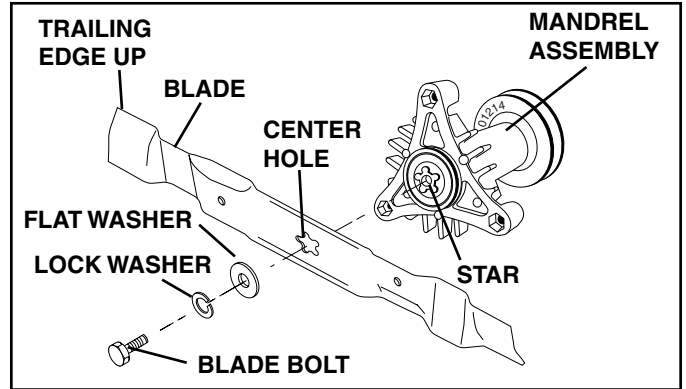

FIG. 10

## TO SHARPEN BLADE (See Fig. 11)

**NOTE:** We do not recommend sharpening blade - but if you do, be sure the blade is balanced.

Care should be taken to keep the blade balanced. An unbalanced blade will cause excessive vibration and eventual damage to mower and engine.

- The blade can be sharpened with a file or on a grinding wheel. Do not attempt to sharpen while on the mower.
- To check blade balance, you will need a 5/8" diameter steel bolt, pin, or a cone balancer. (When using a cone balancer, follow the instructions supplied with balancer.)

**NOTE:** Do not use a nail for balancing blade. The lobes of the center hole may appear to be centered, but are not.

- Slide blade on to an unthreaded portion of the steel bolt or pin and hold the bolt or pin parallel with the ground. If blade is balanced, it should remain in a horizontal position. If either end of the blade moves downward, sharpen the heavy end until the blade is balanced.

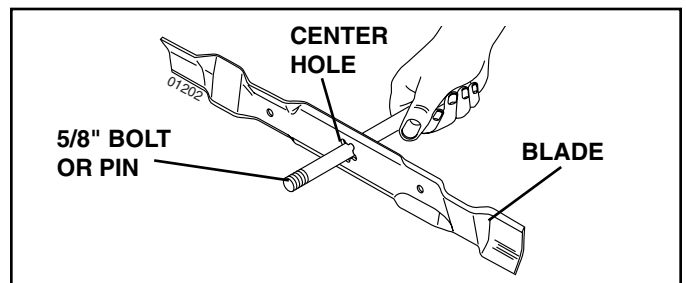

FIG. 11

## BATTERY

Your tractor has a battery charging system which is sufficient for normal use. However, periodic charging of the battery with an automotive charger will extend its life.

- Keep battery and terminals clean.
- Keep battery bolts tight.
- Keep small vent holes open.
- Recharge at 6-10 amperes for 1 hour.

**NOTE:** The original equipment battery on your tractor is maintenance free. Do not attempt to open or remove caps or covers. Adding or checking level of electrolyte is not necessary.



# MAINTENANCE

## TO CLEAN BATTERY AND TERMINALS

Corrosion and dirt on the battery and terminals can cause the battery to “leak” power.

- Remove terminal guard.
- Disconnect BLACK battery cable first then RED battery cable and remove battery from tractor.
- Rinse the battery with plain water and dry.
- Clean terminals and battery cable ends with wire brush until bright.
- Coat terminals with grease or petroleum jelly.
- Reinstall battery (See “CONNECT BATTERY” in the Assembly section of this manual).

## V-BELTS

Check V-belts for deterioration and wear after 100 hours of operation and replace if necessary. The belts are not adjustable. Replace belts if they begin to slip from wear.

## TRANSAXLE COOLING

Keep transaxle free from build-up of dirt and chaff which can restrict cooling.

## ENGINE

### LUBRICATION

Only use high quality detergent oil rated with API service classification SF-SJ. Select the oil’s SAE viscosity grade according to your expected operating temperature. When operating in temperatures below 0° F (-18° C) synthetic oil must be used.

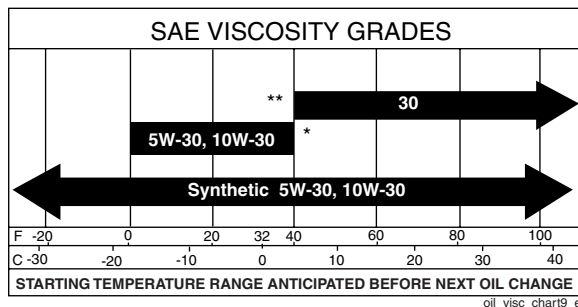

**\* CAUTION:** Air cooled engines run hotter than automotive engines. The use of non-synthetic multi-viscosity oils (5W30, 10W30 etc.) in temperatures above 40° F (4° C) will result in higher than normal oil consumption. When using a multi-viscosity oil, check oil level more frequently.

**\*\* CAUTION:** SAE 30 oil, if used below 40° F (4° C), will result in hard starting and possible engine bore damage due to inadequate lubrication.



**NOTE:** Synthetic oil meeting ILSAC GF-2, API certification mark and API service symbol (shown at left) with "SJ/CF ENERGY CONSERVING" or higher, is an acceptable oil at all temperatures.



**Use of synthetic oil does not alter required oil change intervals.**

Change the oil after every 50 hours of operation or at least once a year if the tractor is not used for 50 hours in one year.

Check the crankcase oil level before starting the engine and after each eight (8) hours of operation. Tighten oil fill cap/dipstick securely each time you check the oil level.

## TO CHANGE ENGINE OIL (See Fig. 12)

Determine temperature range expected before oil change. All oil must meet API service classification SF-SJ.

- Be sure tractor is on level surface.
- Oil will drain more freely when warm.
- Catch oil in a suitable container.
- Remove oil fill cap/dipstick. Be careful not to allow dirt to enter the engine when changing oil.
- Remove yellow cap from end of drain valve and install the drain tube onto the fitting.

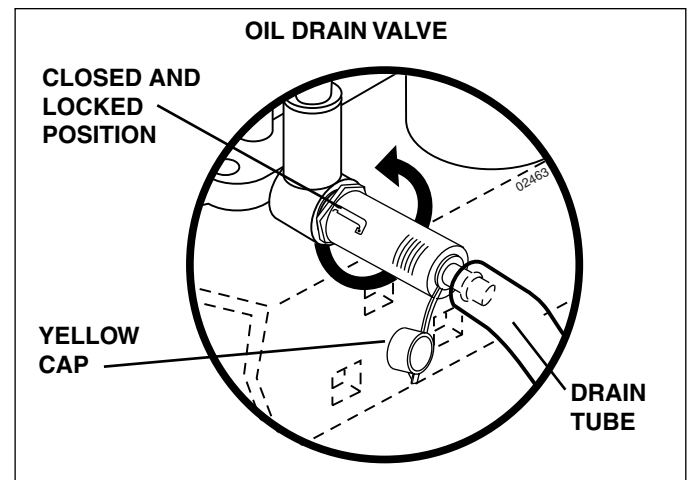

FIG. 12

- Unlock drain valve by pushing inward and turning counterclockwise.
- To open, pull out on the drain valve.
- After oil has drained completely, close and lock the drain valve by pushing inward and turning clockwise until the pin is in the locked position as shown.
- Remove the drain tube and replace the cap onto to the bottom fitting of the drain valve.
- Refill engine with oil through oil fill dipstick tube. Pour slowly. Do not overfill. For approximate capacity see “PRODUCT SPECIFICATIONS” section of this manual.
- Use gauge on oil fill cap/dipstick for checking level. Be sure dipstick cap is tightened securely for accurate reading. Keep oil at “FULL” line on dipstick. Tighten cap onto the tube securely when finished.

## ENGINE OIL FILTER

Replace the engine oil filter every season or every other oil change if the tractor is used more than 100 hours in one year.

# MAINTENANCE

## CLEAN AIR INTAKE/COOLING AREAS

To insure proper cooling, make sure the grass screen, cooling fins, and other external surfaces of the engine are kept clean at all times.

Every 100 hours of operation (more often under extremely dusty, dirty conditions), remove the blower housing and other cooling shrouds. Clean the cooling fins and external surfaces as necessary. Make sure the cooling shrouds are reinstalled.

**NOTE:** Operating the engine with a blocked grass screen, dirty or plugged cooling fins, and/or cooling shrouds removed will cause engine damage due to overheating.

## CLEAN AIR SCREEN

Air screen must be kept free of dirt and chaff to prevent engine damage from overheating. Clean with a wire brush or compressed air to remove dirt and stubborn dried gum fibers.

## AIR FILTER (See Fig. 13)

Your engine will not run properly using a dirty air filter. Clean the foam pre-cleaner after every 25 hours of operation or every season. Service paper cartridge every 100 hours of operation or every season, whichever occurs first.

Service air cleaner more often under dusty conditions.

- Remove cover.

### TO SERVICE PRE-CLEANER

- Wash it in liquid detergent and water.
- Squeeze it dry in a clean cloth.
- Saturate it in engine oil. Wrap it in clean, absorbent cloth and squeeze to remove excess oil.
- If very dirty or damaged, replace pre-cleaner.

### TO SERVICE CARTRIDGE

- Clean cartridge by tapping gently on flat surface. If very dirty or damaged, replace cartridge.
- Reinstall pre-cleaner cartridge, cover and secure.

**IMPORTANT:** PETROLEUM SOLVENTS, SUCH AS KEROSENE, ARE NOT TO BE USED TO CLEAN THE CARTRIDGE. THEY MAY CAUSE DETERIORATION OF THE CARTRIDGE. DO NOT OIL CARTRIDGE. DO NOT USE PRESSURIZED AIR TO CLEAN OR DRY CARTRIDGE.

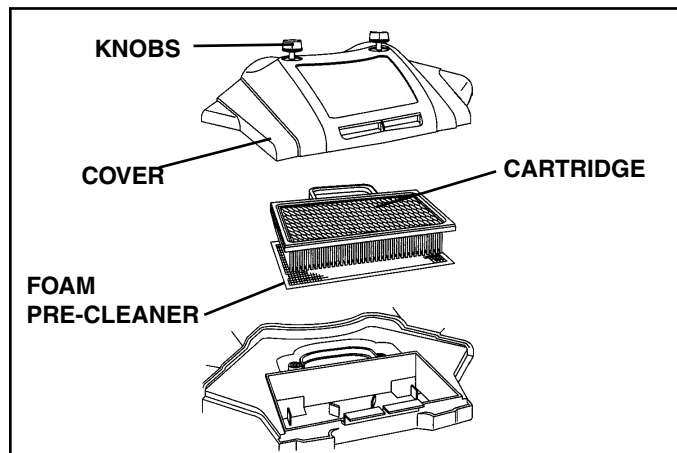

FIG. 13

## MUFFLER

Inspect and replace corroded muffler and spark arrester (if equipped) as it could create a fire hazard and/or damage.

## SPARK PLUGS

Replace spark plugs at the beginning of each mowing season or after every 100 hours of operation, whichever occurs first. Spark plug type and gap setting are shown in "PRODUCT SPECIFICATIONS" section of this manual.

## IN-LINE FUEL FILTER (See Fig. 14)

The fuel filter should be replaced once each season. If fuel filter becomes clogged, obstructing fuel flow to carburetor, replacement is required.

- With engine cool, remove filter and plug fuel line sections.
- Place new fuel filter in position in fuel line with arrow pointing towards carburetor.
- Be sure there are no fuel line leaks and clamps are properly positioned.
- Immediately wipe up any spilled gasoline.

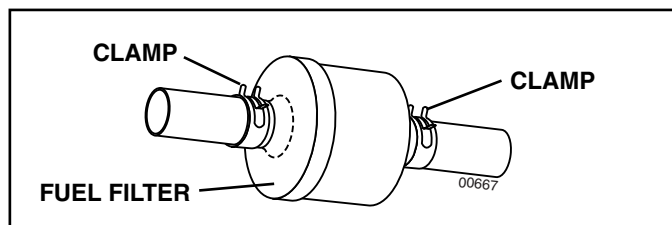

FIG. 14

## CLEANING

- Clean engine, battery, seat, finish, etc. of all foreign matter.
- Keep finished surfaces and wheels free of all gasoline, oil, etc.
- Protect painted surfaces with automotive type wax.

We do not recommend using a garden hose or pressure washer to clean your tractor unless the engine and transmission are covered to keep water out. Water in engine or transmission will shorten the useful life of your tractor. Use compressed air or a leaf blower to remove grass, leaves and trash from tractor and mower.

# SERVICE AND ADJUSTMENTS



**WARNING: TO AVOID SERIOUS INJURY, BEFORE PERFORMING ANY SERVICE OR ADJUSTMENTS:**

- Depress clutch/brake pedal fully and set parking brake.
- Place gearshift lever in neutral (N) position.
- Place attachment clutch in “DISENGAGED” position.
- Turn ignition key to “STOP” and remove key.
- Make sure the blades and all moving parts have completely stopped.
- Disconnect spark plug wire from spark plug and place wire where it cannot come in contact with plug.

## TO REMOVE MOWER (See Fig. 15)

Mower will be easier to remove from the right side of tractor.

- Place attachment clutch in “DISENGAGED” position.
- Move attachment lift lever forward to lower mower to its lowest position.
- Roll belt off engine pulley.
- Remove small retainer spring, and remove clutch spring off pulley bolt.
- Remove large retainer spring, slide collar off and push housing guide out of bracket.
- Disconnect anti-swaybar from chassis bracket by removing retainer spring.
- Disconnect suspension arms from rear deck brackets by removing retainer springs.
- Disconnect front links from deck by removing retainer springs.
- Raise lift lever to raise suspension arms. Slide mower out from under tractor.

**IMPORTANT: IF AN ATTACHMENT OTHER THAN THE MOWER DECK IS TO BE MOUNTED ON THE TRACTOR, REMOVE THE FRONT LINKS AND HOOK THE CLUTCH SPRING INTO SQUARE HOLE IN FRAME.**

## TO INSTALL MOWER (See Fig. 15)

- Raise attachment lift lever to its highest position.
- Slide mower under tractor with deflector shield to right side of tractor.
- Lower lift lever to its lowest position.
- Connect front links to mower deck and secure with retainer springs..
- Connect suspension arms to rear deck brackets and secure with retainer springs.
- Connect anti-swaybar to chassis bracket and secure with retainer spring.
- Push clutch cable housing guide into bracket, slide collar onto guide and secure with large retainer spring.

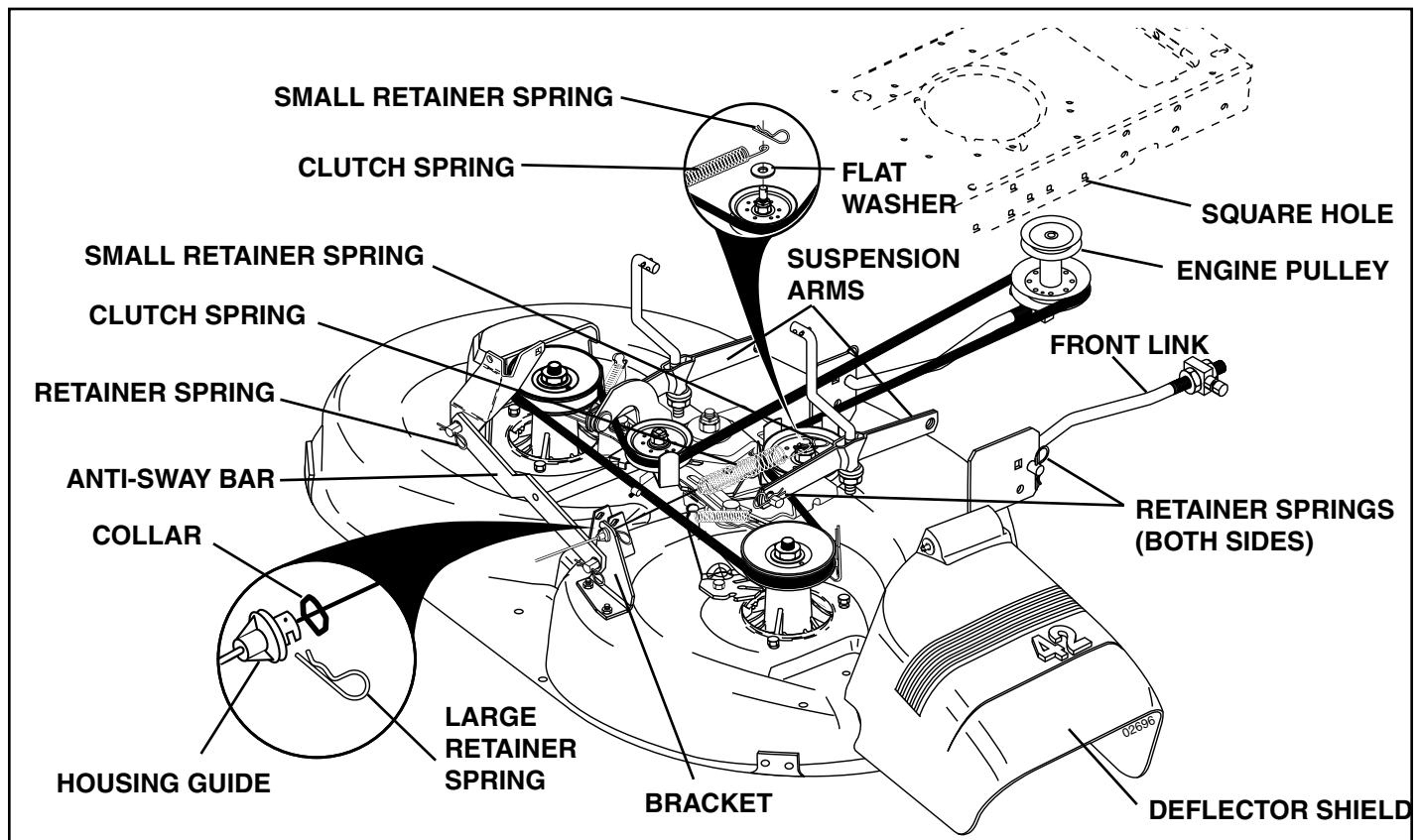

FIG. 15

# SERVICE AND ADJUSTMENTS

- Place flat washer and clutch spring on idler pulley bolt and secure with small retainer spring.
- Install belt onto engine pulley.

## TO LEVEL MOWER HOUSING

Adjust the mower while tractor is parked on level ground or driveway. Make sure tires are properly inflated (See "PRODUCT SPECIFICATIONS" section of this manual). If tires are over or underinflated, you will not properly adjust your mower.

### SIDE-TO-SIDE ADJUSTMENT (See Figs. 16 and 17)

- Raise mower to its highest position.
- At the midpoint of both sides of mower, measure height from bottom edge of mower to ground. Distance "A" on both sides of mower should be the same or within 1/4" of each other.
- If adjustment is necessary, make adjustment on one side of mower only.
- To raise one side of mower, tighten lift link adjustment nut on that side.
- To lower one side of mower, loosen lift link adjustment nut on that side.

**NOTE:** Each full turn of adjustment nut will change mower height about 1/8".

- Recheck measurements after adjusting.

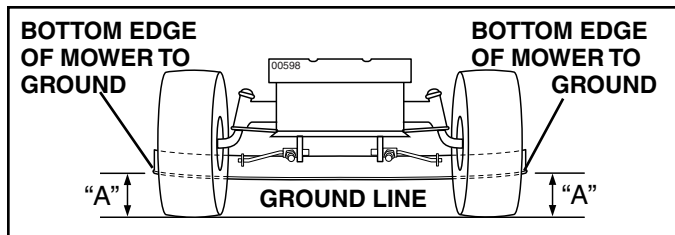

FIG. 16

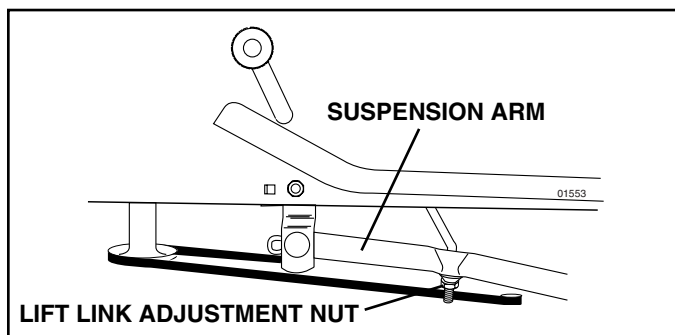

FIG. 17

### FRONT-TO-BACK ADJUSTMENT (See Figs. 18 and 19)

**IMPORTANT:** DECK MUST BE LEVEL SIDE-TO-SIDE. IF THE FOLLOWING FRONT-TO-BACK ADJUSTMENT IS NECESSARY, BE SURE TO ADJUST BOTH FRONT LINKS EQUALLY SO MOWER WILL STAY LEVEL SIDE-TO-SIDE.

To obtain the best cutting results, the mower housing should be adjusted so that the front is approximately 1/8" to 1/2" lower than the rear when the mower is in its highest position.

Check adjustment on right side of tractor. Measure distance "D" directly in front and behind the mandrel at bottom edge of mower housing as shown.

- Before making any necessary adjustments, check that both front links are equal in length.
- If links are not equal in length, adjust one link to same length as other link.
- To lower front of mower loosen nut "E" on both front links an equal number of turns.
- When distance "D" is 1/8" to 1/2" lower at front than rear, tighten nuts "F" against trunnion on both front links.
- To raise front of mower, loosen nut "F" from trunnion on both front links. Tighten nut "E" on both front links an equal number of turns. The two front links must remain equal in length.
- When distance "D" is 1/8" to 1/2" lower at front than rear, tighten nut "F" against trunnion on both front links.
- Recheck side-to-side adjustment.

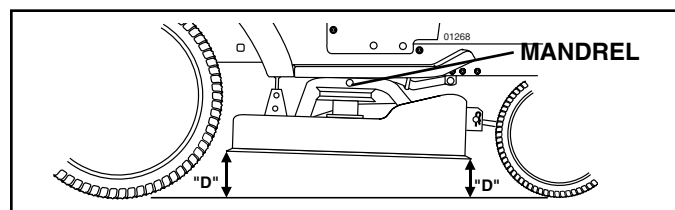

FIG. 18

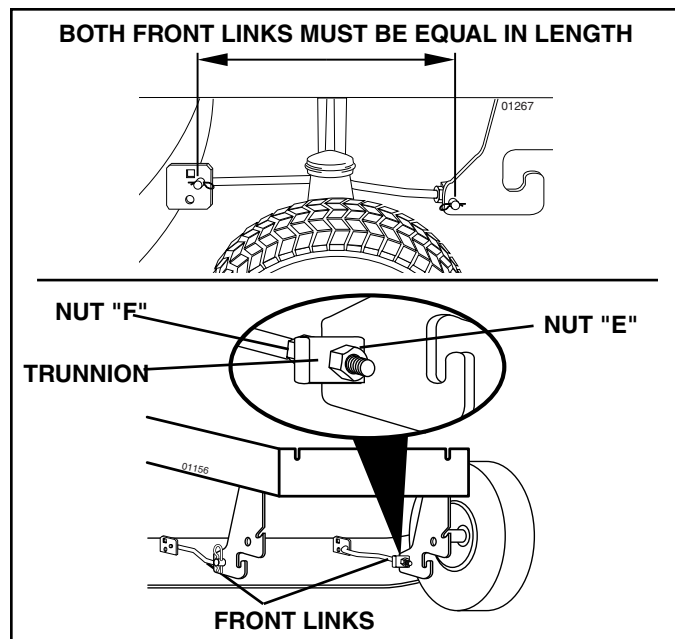

FIG. 19

## TO REPLACE MOWER BLADE DRIVE BELT (See Fig. 20)

The mower blade drive belt may be replaced without tools. Park the tractor on level surface. Engage parking brake.

### BELT REMOVAL

- Remove mower from tractor (See "TO REMOVE MOWER" in this section of this manual).

# SERVICE AND ADJUSTMENTS

- Work belt off both mandrel pulleys and idler pulleys.
- Pull belt away from mower.

## BELT INSTALLATION

- Install new belt in reverse order of removal.
- Make sure belt is in all pulley grooves and inside all belt guides.
- Install mower in reverse order of removal instructions.

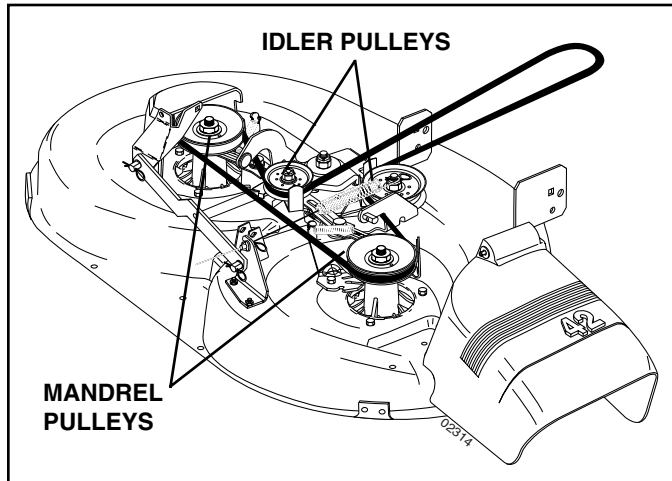

FIG. 20

## TO CHECK AND ADJUST BRAKE (See Fig. 21)

Your tractor is equipped with an adjustable brake system which is mounted on the right side of the transaxle.

If tractor requires more than five (5) feet to stop at highest speed in highest gear on a level, dry concrete or paved surface, then brake must be checked and adjusted.

### TO CHECK BRAKE

- Park tractor on a level, dry concrete or paved surface, depress clutch/brake pedal all the way down and engage parking brake.
- Place gear shift lever in neutral (N) position.

The rear wheels must lock and skid when you try to manually push the tractor forward. If the rear wheels rotate, the brake needs to be adjusted or the pads need to be replaced.

### TO ADJUST BRAKE

- Depress clutch/brake pedal all the way down and engage parking brake.
- Measure distance between brake operating arm and nut "A" on brake rod.
- If distance is other than 1-1/2", loosen jam nut and turn nut "A" until distance becomes 1-1/2". Retighten jam nut against nut "A".
- Road test tractor for proper stopping distance as stated above. Readjust if necessary. If stopping distance is still greater than five (5) feet in highest gear, further maintenance is necessary. Replace brake pads or contact a qualified service center.

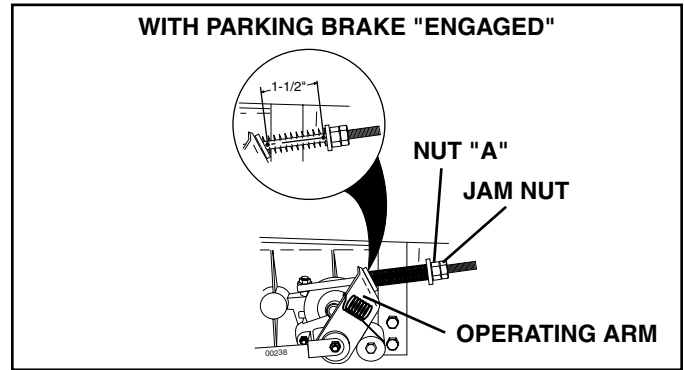

FIG. 21

## TO REPLACE MOTION DRIVE BELT (See Fig. 22)

Park the tractor on level surface. Engage parking brake. For assistance, there is a belt installation guide decal on bottom side of left footrest.

### BELT REMOVAL -

- Remove mower (See "TO REMOVE MOWER" in this section of manual).
- NOTE:** Observe entire motion drive belt and position of all belt guides and keepers.
- Remove belt from stationary idler and clutching idler.
- Remove belt downward from around engine pulley.
- Pull belt slack toward rear of tractor. Remove belt upwards from transaxle pulley by deflecting belt keepers.
- Remove belt from center span keeper and pull belt away from tractor.

### BELT INSTALLATION -

- Carefully work new belt down between transaxle belt keepers and onto the input pulley.
- Slide belt into the center span keeper.
- Pull belt toward front of tractor and roll around the top groove of engine pulley.
- Install belt through stationary idler and clutching idler.
- Make sure belt is in all pulley grooves and inside all belt guides and keepers.
- Install mower (See "TO INSTALL MOWER" in this section of manual).

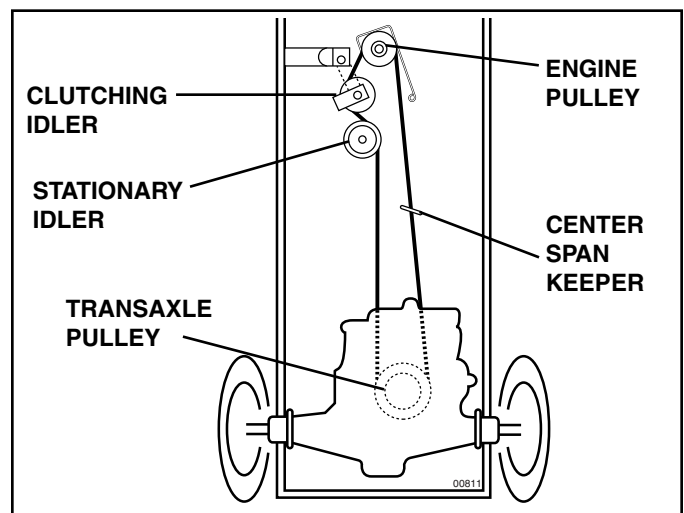

FIG. 22

# SERVICE AND ADJUSTMENTS

## TRANSAXLE GEAR SHIFT LEVER NEUTRAL ADJUSTMENT (See Fig. 23)

The transaxle should be in neutral when the gear shift lever is in neutral (N) (lock gate) position. The adjustment is preset at the factory; however, if adjustment is needed, proceed as follows:

- Make sure transaxle is in neutral (N).

**NOTE:** When the tractor rear wheels move freely, the transaxle is in neutral.

- Loosen adjustment bolt in front of the right rear wheel.
- Position the gear shift lever in the neutral (N) position.
- Tighten adjustment bolt securely.

**NOTE:** If additional clearance is needed to get to adjustment bolt, move mower deck height to the lowest position.

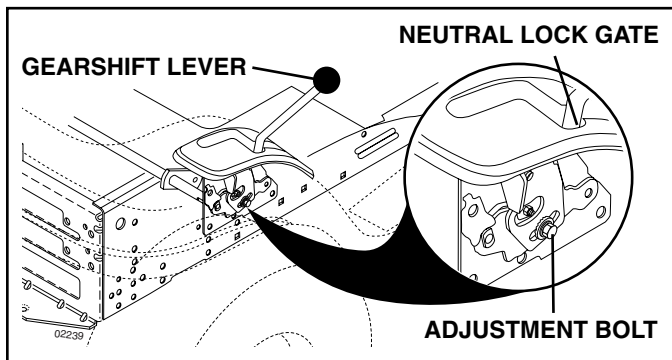

FIG. 23

## TO ADJUST STEERING WHEEL ALIGNMENT

If steering wheel crossbars are not horizontal (left to right) when wheels are positioned straight forward, remove steering wheel and reassemble per instructions in the Assembly section of this manual.

## FRONT WHEEL TOE-IN/CAMBER

The front wheel toe-in and camber are not adjustable on your tractor. If damage has occurred to affect the front wheel toe-in or camber, contact your nearest authorized service center/department.

## TO REMOVE WHEEL FOR REPAIRS

(See Fig. 24)

- Block up axle securely.
- Remove axle cover, retaining ring and washers to allow wheel removal (rear wheel contains a square key - Do not lose).
- Repair tire and reassemble.
- On rear wheels only: align grooves in rear wheel hub and axle. Insert square key.
- Replace washers and snap retaining ring securely in axle groove.
- Replace axle cover.

**NOTE:** To seal tire punctures and prevent flat tires due to slow leaks, tire sealant may be purchased from your local parts dealer. Tire sealant also prevents tire dry rot and corrosion.

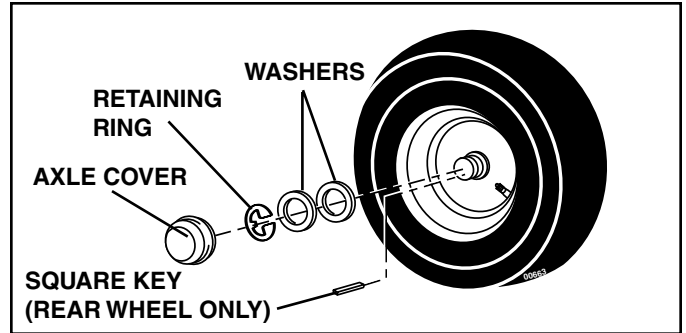

FIG. 24

## TO START ENGINE WITH A WEAK BATTERY (See Fig. 25)



**WARNING:** Lead-acid batteries generate explosive gases. Keep sparks, flame and smoking materials away from batteries. Always wear eye protection when around batteries.

If your battery is too weak to start the engine, it should be recharged. (See "BATTERY" in the Maintenance section of this manual).

If "jumper cables" are used for emergency starting, follow this procedure:

**IMPORTANT:** YOUR TRACTOR IS EQUIPPED WITH A 12 VOLT SYSTEM. THE OTHER VEHICLE MUST ALSO BE A 12 VOLT SYSTEM. DO NOT USE YOUR TRACTOR BATTERY TO START OTHER VEHICLES.

TO ATTACH JUMPER CABLES -

- Connect one end of the RED cable to the POSITIVE (+) terminal of each battery(A-B), taking care not to short against tractor chassis.
- Connect one end of the BLACK cable to the NEGATIVE (-) terminal (C) of fully charged battery.
- Connect the other end of the BLACK cable (D) to good chassis ground, away from fuel tank and battery.

TO REMOVE CABLES, REVERSE ORDER -

- BLACK cable first from chassis and then from the fully charged battery.
- RED cable last from both batteries.

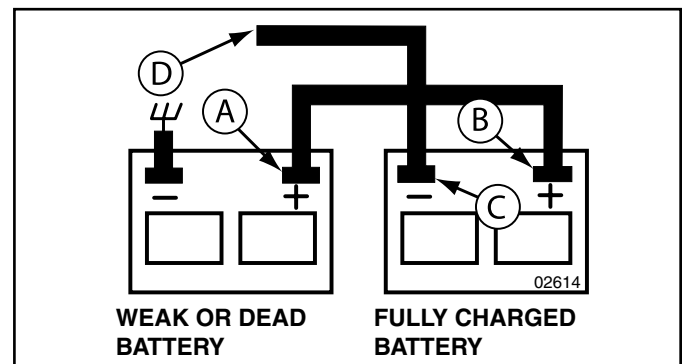

FIG. 25

# SERVICE AND ADJUSTMENTS

## TO REPLACE HEADLIGHT BULB

- Raise hood.
- Pull bulb holder out of the hole in the backside of the grill.
- Replace bulb in holder and push bulb holder securely back into the hole in the backside of the grill.
- Close hood.

## INTERLOCKS AND RELAYS

Loose or damaged wiring may cause your tractor to run poorly, stop running, or prevent it from starting.

- Check wiring. See electrical wiring diagram in the Repair Parts section.

## TO REPLACE FUSE

Replace with 20 amp automotive-type plug-in fuse. The fuse holder is located behind the dash.

## TO REMOVE HOOD AND GRILL ASSEMBLY (See Fig. 26)

- Raise hood.
- Unsnap headlight wire connector.
- Stand in front of tractor. Grasp hood at sides, tilt toward engine and lift off of tractor.
- To replace, reverse above procedure.

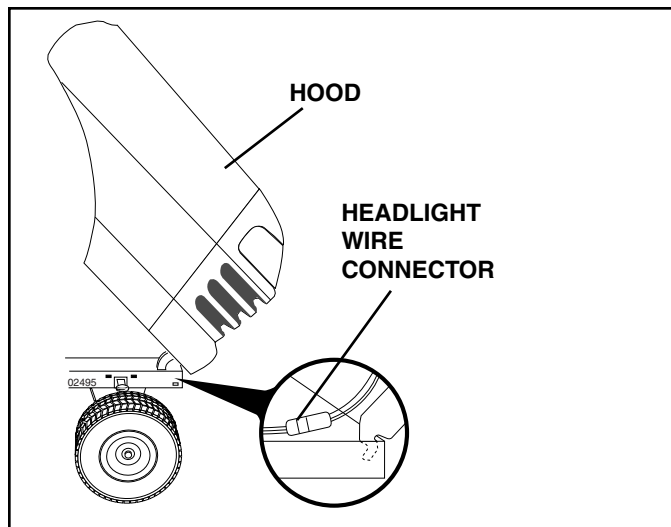

FIG. 26

## ENGINE

## TO ADJUST THROTTLE CONTROL CABLE (See Fig. 27)

The throttle control has been preset at the factory and adjustment should not be necessary. Check adjustment as described below before loosening cable. If adjustment is necessary, proceed as follows:

- With engine not running, move throttle control lever to fast position.
- Check that swivel is against stop. If it is not, loosen cable clamp screw and pull cable back until swivel is against stop. Tighten cable clamp screw securely.

## TO ADJUST CHOKE CONTROL (See Fig. 28)

The choke control has been preset at the factory and adjustment should not be necessary. Check adjustment as described below before loosening cable. If adjustment is necessary, proceed as follows:

- With engine not running, move choke control (located on dash panel) to full choke position.
- Loosen knob and remove cover assembly from air cleaner.
- Choke should be closed. If it is not, loosen casing clamp screw and move choke cable until choke is completely closed. Tighten casing clamp screw securely.
- Replace air cleaner cover assembly and tighten knob.

## TO ADJUST CARBURETOR

Your carburetor is not adjustable. If your engine does not operate properly due to suspected carburetor problems, take your tractor to an authorized service center for repair and/or adjustment.

High speed stop is factory adjusted. Do not adjust - damage may result.

**IMPORTANT: NEVER TAMPER WITH THE ENGINE GOVERNOR, WHICH IS FACTORY SET FOR PROPER ENGINE SPEED. OVERSPEEDING THE ENGINE ABOVE THE FACTORY HIGH SPEED SETTING CAN BE DANGEROUS. IF YOU THINK THE ENGINE-GOVERNED HIGH SPEED NEEDS ADJUSTING, CONTACT YOUR NEAREST AUTHORIZED SERVICE CENTER/DEPARTMENT, WHICH HAS PROPER EQUIPMENT AND EXPERIENCE TO MAKE ANY NECESSARY ADJUSTMENTS.**

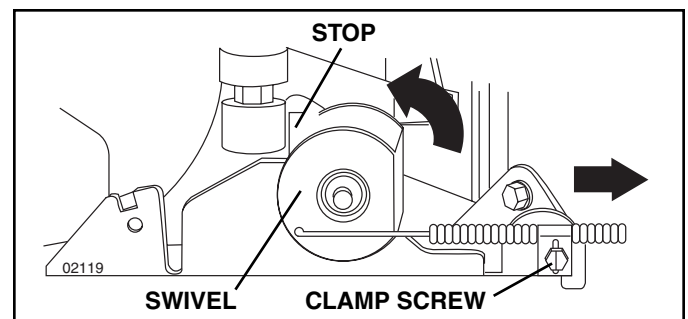

FIG. 27

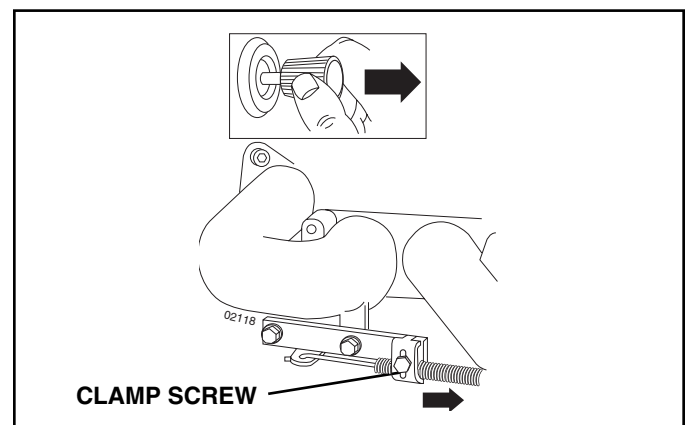

FIG. 28

# STORAGE

Immediately prepare your tractor for storage at the end of the season or if the tractor will not be used for 30 days or more.



**WARNING: Never store the tractor with gasoline in the tank inside a building where fumes may reach an open flame or spark. Allow the engine to cool before storing in any enclosure.**

## TRACTOR

Remove mower from tractor for winter storage. When mower is to be stored for a period of time, clean it thoroughly, remove all dirt, grease, leaves, etc. Store in a clean, dry area.

- Clean entire tractor (See “CLEANING” in the Maintenance section of this manual).
- Inspect and replace belts, if necessary (See belt replacement instructions in the Service and Adjustments section of this manual).
- Lubricate as shown in the Maintenance section of this manual.
- Be sure that all nuts, bolts and screws are securely fastened. Inspect moving parts for damage, breakage and wear. Replace if necessary.
- Touch up all rusted or chipped paint surfaces; sand lightly before painting.

## BATTERY

- Fully charge the battery for storage.
- After a period of time in storage, battery may require recharging.
- To help prevent corrosion and power leakage during long periods of storage, battery cables should be disconnected and battery cleaned thoroughly (see “TO CLEAN BATTERY AND TERMINALS” in the Maintenance section of this manual).
- After cleaning, leave cables disconnected and place cables where they cannot come in contact with battery terminals.
- If battery is removed from tractor for storage, do not store battery directly on concrete or damp surfaces.

## ENGINE

### FUEL SYSTEM

**IMPORTANT:** IT IS IMPORTANT TO PREVENT GUM DEPOSITS FROM FORMING IN ESSENTIAL FUEL SYSTEM PARTS SUCH AS CARBURETOR, FUEL FILTER, FUEL HOSE, OR TANK DURING STORAGE. ALSO, EXPERIENCE INDICATES THAT ALCOHOL BLENDED FUELS (CALLED GASOHOL OR USING ETHANOL OR METHANOL) CAN ATTRACT MOISTURE WHICH LEADS TO SEPARATION AND FORMATION OF ACIDS DURING STORAGE. ACIDIC GAS CAN DAMAGE THE FUEL SYSTEM OF AN ENGINE WHILE IN STORAGE.

- Empty the fuel tank by starting the engine and let it run until the fuel lines and carburetor are empty.
- Never use engine or carburetor cleaner products in the fuel tank or permanent damage may occur.
- Use fresh fuel next season.

**NOTE:** Fuel stabilizer is an acceptable alternative in minimizing the formation of fuel gum deposits during storage. Add stabilizer to gasoline in fuel tank or storage container. Always follow the mix ratio found on stabilizer container. Run engine at least 10 minutes after adding stabilizer to allow the stabilizer to reach the carburetor. Do not empty the gas tank and carburetor if using fuel stabilizer.

### ENGINE OIL

Drain oil (with engine warm) and replace with clean engine oil. (See “ENGINE” in the Maintenance section of this manual).

### CYLINDER(S)

- Remove spark plug(s).
- Pour one ounce of oil through spark plug hole(s) into cylinder(s).
- Turn ignition key to “START” position for a few seconds to distribute oil.
- Replace with new spark plug(s).

## OTHER

- Do not store gasoline from one season to another.
- Replace your gasoline can if your can starts to rust. Rust and/or dirt in your gasoline will cause problems.
- If possible, store your tractor indoors and cover it to give protection from dust and dirt.
- Cover your tractor with a suitable protective cover that does not retain moisture. Do not use plastic. Plastic cannot breathe which allows condensation to form and will cause your tractor to rust.

**IMPORTANT:** NEVER COVER TRACTOR WHILE ENGINE AND EXHAUST AREAS ARE STILL WARM.



# TROUBLESHOOTING POINTS

PROBLEM	CAUSE	CORRECTION
<b>Will not start</b>	<ol style="list-style-type: none"> <li>1. Out of fuel.</li> <li>2. Engine not "CHOKED" properly.</li> <li>3. Engine flooded.</li> <li>4. Bad spark plug.</li> <li>5. Dirty air filter.</li> <li>6. Dirty fuel filter.</li> <li>7. Water in fuel.</li>   <li>8. Loose or damaged wiring.</li> <li>9. Carburetor out of adjustment.</li>   <li>10. Engine valves out of adjustment.</li> </ol>	<ol style="list-style-type: none"> <li>1. Fill fuel tank.</li> <li>2. See "TO START ENGINE" in Operation section.</li> <li>3. Wait several minutes before attempting to start.</li> <li>4. Replace spark plug.</li> <li>5. Clean/replace air filter.</li> <li>6. Replace fuel filter.</li> <li>7. Empty fuel tank and carburetor, refill tank with fresh gasoline and replace fuel filter.</li> <li>8. Check all wiring.</li> <li>9. See "To Adjust Carburetor" in Service Adjustments section.</li> <li>10. Contact an authorized service center/department.</li> </ol>
<b>Hard to start</b>	<ol style="list-style-type: none"> <li>1. Dirty air filter.</li> <li>2. Bad spark plug.</li> <li>3. Weak or dead battery.</li> <li>4. Dirty fuel filter.</li> <li>5. Stale or dirty fuel.</li> <li>6. Loose or damaged wiring.</li> <li>7. Carburetor out of adjustment.</li>   <li>8. Engine valves out of adjustment.</li> </ol>	<ol style="list-style-type: none"> <li>1. Clean/replace air filter.</li> <li>2. Replace spark plug.</li> <li>3. Recharge or replace battery.</li> <li>4. Replace fuel filter.</li> <li>5. Empty fuel tank and refill tank with fresh, clean gasoline.</li> <li>6. Check all wiring.</li> <li>7. See "To Adjust Carburetor" in Service Adjustments section.</li> <li>8. Contact an authorized service center/department.</li> </ol>
<b>Engine will not turn over</b>	<ol style="list-style-type: none"> <li>1. Clutch/brake pedal not depressed.</li> <li>2. Attachment clutch is engaged.</li> <li>3. Weak or dead battery.</li> <li>4. Blown fuse.</li> <li>5. Corroded battery terminals.</li> <li>6. Loose or damaged wiring.</li> <li>7. Faulty ignition switch.</li> <li>8. Faulty solenoid or starter.</li> <li>9. Faulty operator presence switch(es).</li> </ol>	<ol style="list-style-type: none"> <li>1. Depress clutch/brake pedal.</li> <li>2. Disengage attachment clutch.</li> <li>3. Recharge or replace battery.</li> <li>4. Replace fuse.</li> <li>5. Clean battery terminals.</li> <li>6. Check all wiring.</li> <li>7. Check/replace ignition switch.</li> <li>8. Check/replace solenoid or starter.</li> <li>9. Contact an authorized service center/department.</li> </ol>
<b>Engine clicks but will not start</b>	<ol style="list-style-type: none"> <li>1. Weak or dead battery.</li> <li>2. Corroded battery terminals.</li> <li>3. Loose or damaged wiring.</li> <li>4. Faulty solenoid or starter.</li> </ol>	<ol style="list-style-type: none"> <li>1. Recharge or replace battery.</li> <li>2. Clean battery terminals.</li> <li>3. Check all wiring.</li> <li>4. Check/replace solenoid or starter.</li> </ol>
<b>Loss of power</b>	<ol style="list-style-type: none"> <li>1. Cutting too much grass/too fast.</li> <li>2. Throttle in "CHOKE" position.</li> <li>3. Build-up of grass, leaves and trash under mower.</li> <li>4. Dirty air filter.</li> <li>5. Low oil level/dirty oil.</li> <li>6. Faulty spark plug.</li> <li>7. Dirty fuel filter.</li> <li>8. Stale or dirty fuel.</li> <li>9. Water in fuel.</li>   <li>10. Spark plug wire loose.</li> <li>11. Dirty engine air screen/fins.</li> <li>12. Dirty/clogged muffler.</li> <li>13. Loose or damaged wiring.</li> <li>14. Carburetor out of adjustment.</li>   <li>15. Engine valves out of adjustment.</li> </ol>	<ol style="list-style-type: none"> <li>1. Raise cutting height/reduce speed.</li> <li>2. Adjust throttle control.</li> <li>3. Clean underside of mower housing.</li> <li>4. Clean/replace air filter.</li> <li>5. Check oil level/change oil.</li> <li>6. Clean and regap or change spark plug.</li> <li>7. Replace fuel filter.</li> <li>8. Empty fuel tank and refill tank with fresh, clean gasoline.</li> <li>9. Empty fuel tank and carburetor, refill tank with fresh gasoline and replace fuel filter.</li> <li>10. Connect and tighten spark plug wire.</li> <li>11. Clean engine air screen/fins.</li> <li>12. Clean/replace muffler.</li> <li>13. Check all wiring.</li> <li>14. See "To Adjust Carburetor" in Service Adjustments section.</li> <li>15. Contact an authorized service center/department.</li> </ol>
<b>Excessive vibration</b>	<ol style="list-style-type: none"> <li>1. Worn, bent or loose blade.</li> <li>2. Bent blade mandrel.</li> <li>3. Loose/damaged part(s).</li> </ol>	<ol style="list-style-type: none"> <li>1. Replace blade. Tighten blade bolt.</li> <li>2. Replace blade mandrel.</li> <li>3. Tighten loose part(s). Replace damaged parts.</li> </ol>

# TROUBLESHOOTING POINTS

PROBLEM	CAUSE	CORRECTION
<b>Engine continues to run when operator leaves seat with attachment clutch engaged</b>	<ol style="list-style-type: none"> <li>1. Faulty operator-safety presence control system.</li> </ol>	<ol style="list-style-type: none"> <li>1. Check wiring, switches and connections. If not corrected, contact an authorized service center/department.</li> </ol>
<b>Poor cut - uneven</b>	<ol style="list-style-type: none"> <li>1. Worn, bent or loose blade.</li> <li>2. Mower deck not level.</li> <li>3. Buildup of grass, leaves, and trash under mower.</li> <li>4. Bent blade mandrel.</li> <li>5. Clogged mower deck vent holes from buildup of grass, leaves, and trash around mandrels.</li> </ol>	<ol style="list-style-type: none"> <li>1. Replace blade. Tighten blade bolt.</li> <li>2. Level mower deck.</li> <li>3. Clean underside of mower housing.</li> <li>4. Replace blade mandrel.</li> <li>5. Clean around mandrels to open vent holes.</li> </ol>
<b>Mower blades will not rotate</b>	<ol style="list-style-type: none"> <li>1. Obstruction in clutch mechanism.</li> <li>2. Worn/damaged mower drive belt.</li> <li>3. Frozen idler pulley.</li> <li>4. Frozen blade mandrel.</li> </ol>	<ol style="list-style-type: none"> <li>1. Remove obstruction.</li> <li>2. Replace mower drive belt.</li> <li>3. Replace idler pulley.</li> <li>4. Replace blade mandrel.</li> </ol>
<b>Poor grass discharge</b>	<ol style="list-style-type: none"> <li>1. Engine speed too slow.</li> <li>2. Travel speed too fast.</li> <li>3. Wet grass.</li> <li>4. Mower deck not level.</li> <li>5. Low/uneven tire air pressure.</li> <li>6. Worn, bent or loose blade.</li> <li>7. Buildup of grass, leaves and trash under mower.</li> <li>8. Mower drive belt worn.</li> <li>9. Blades improperly installed.</li> <li>10. Improper blades used.</li> <li>11. Clogged mower deck vent holes from buildup of grass, leaves, and trash around mandrels.</li> </ol>	<ol style="list-style-type: none"> <li>1. Place throttle control in "FAST" position.</li> <li>2. Shift to slower speed.</li> <li>3. Allow grass to dry before mowing.</li> <li>4. Level mower deck.</li> <li>5. Check tires for proper air pressure.</li> <li>6. Replace/sharpen blade. Tighten blade bolt.</li> <li>7. Clean underside of mower housing.</li> <li>8. Replace mower drive belt.</li> <li>9. Reinstall blades sharp edge down.</li> <li>10. Replace with blades listed in this manual.</li> <li>11. Clean around mandrels to open vent holes.</li> </ol>
<b>Headlight(s) not working (if so equipped)</b>	<ol style="list-style-type: none"> <li>1. Switch is "OFF".</li> <li>2. Bulb(s) or lamp(s) burned out.</li> <li>3. Faulty light switch.</li> <li>4. Loose or damaged wiring.</li> <li>5. Blown fuse.</li> </ol>	<ol style="list-style-type: none"> <li>1. Turn switch "ON".</li> <li>2. Replace bulb(s) or lamp(s).</li> <li>3. Check/replace light switch.</li> <li>4. Check wiring and connections.</li> <li>5. Replace fuse.</li> </ol>
<b>Battery will not charge</b>	<ol style="list-style-type: none"> <li>1. Bad battery cell(s).</li> <li>2. Poor cable connections.</li> <li>3. Faulty regulator (if so equipped).</li> <li>4. Faulty alternator.</li> </ol>	<ol style="list-style-type: none"> <li>1. Replace battery.</li> <li>2. Check/clean all connections.</li> <li>3. Replace regulator.</li> <li>4. Replace alternator.</li> </ol>
<b>Engine "backfires" when turning engine "OFF"</b>	<ol style="list-style-type: none"> <li>1. Engine throttle control not set at "SLOW" position for 30 seconds before stopping engine.</li> </ol>	<ol style="list-style-type: none"> <li>1. Move throttle control to "SLOW" position and allow to idle for 30 seconds before stopping engine.</li> </ol>

# TRACTOR - - MODEL NUMBER 944.604010

## SCHEMATIC

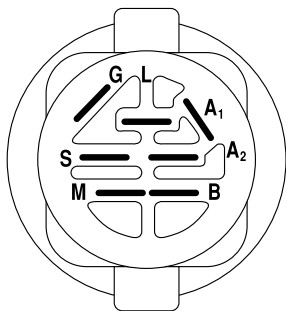
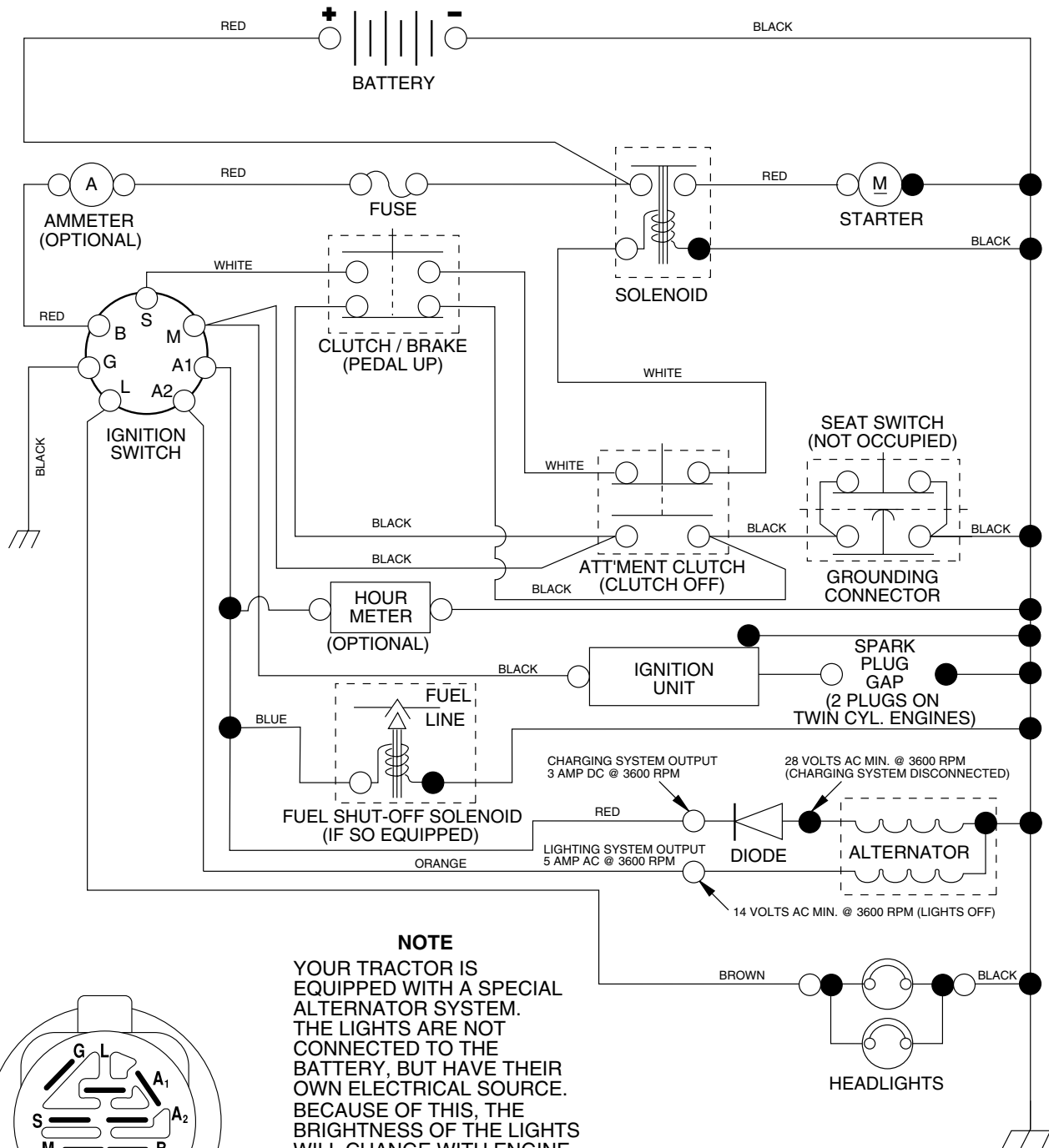

**IGNITION SWITCH**

POSITION	CIRCUIT	"MAKE"
OFF	M+G+A1	NONE
RUN/LIGHT	B+A1	A2+L
RUN	B+A1	NONE
START	B + S + A1	NONE

### NOTE

YOUR TRACTOR IS EQUIPPED WITH A SPECIAL ALTERNATOR SYSTEM. THE LIGHTS ARE NOT CONNECTED TO THE BATTERY, BUT HAVE THEIR OWN ELECTRICAL SOURCE. BECAUSE OF THIS, THE BRIGHTNESS OF THE LIGHTS WILL CHANGE WITH ENGINE SPEED. AT IDLE THE LIGHTS WILL DIM. AS THE ENGINE IS SPEEDED UP, THE LIGHTS WILL BECOME THEIR BRIGHTEST.

### WIRING INSULATED CLIPS

**NOTE:** IF WIRING INSULATED CLIPS WERE REMOVED FOR SERVICING OF UNIT, THEY SHOULD BE REPLACED TO PROPERLY SECURE YOUR WIRING.

NON-REMOVABLE CONNECTIONS

REMOVABLE CONNECTIONS

# REPAIR PARTS

TRACTOR - - MODEL NUMBER 944.604010

## ELECTRICAL

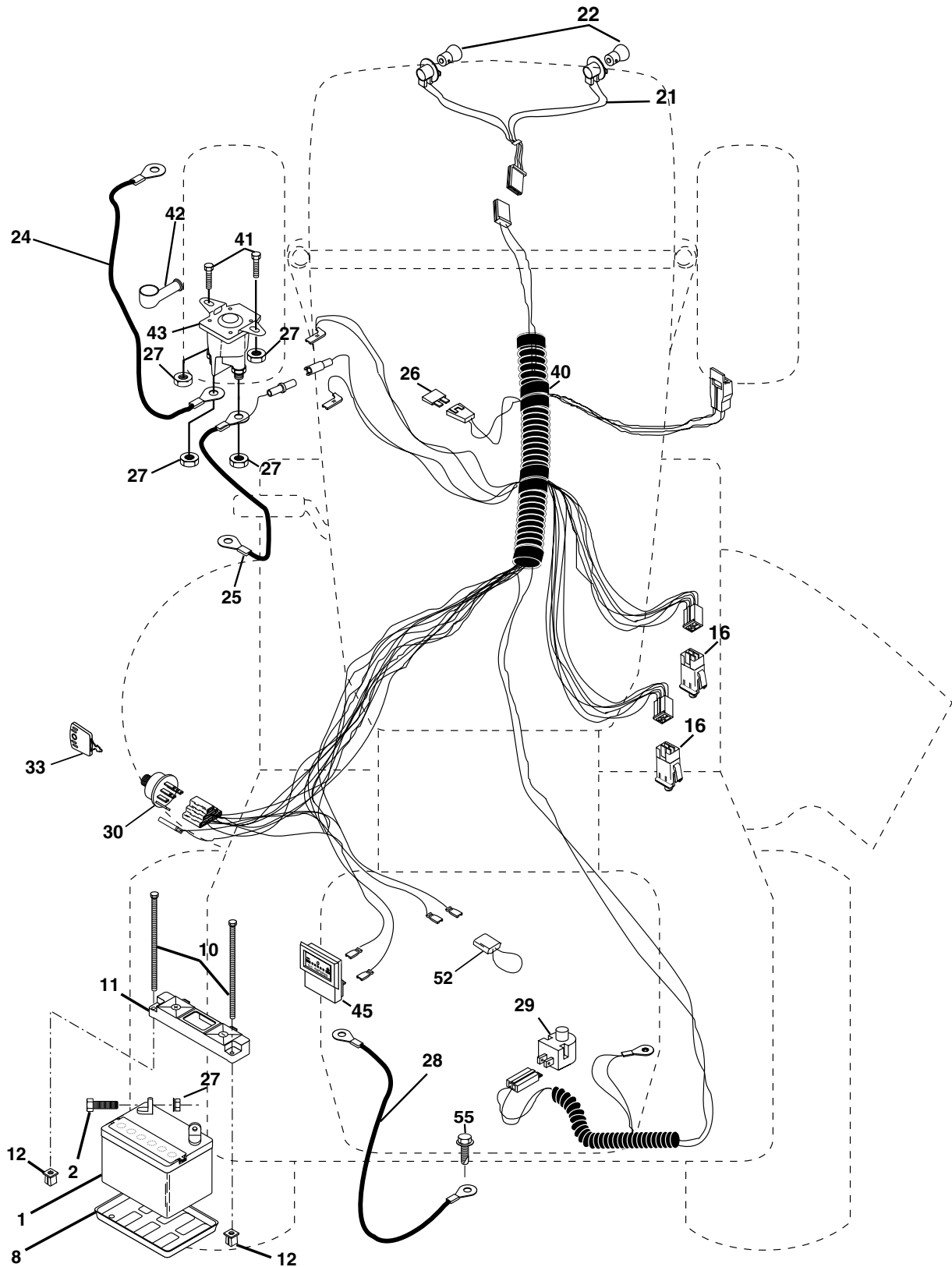

# REPAIR PARTS

## TRACTOR - - MODEL NUMBER 944.604010

### ELECTRICAL

KEY NO.	PART NO.	DESCRIPTION
1	144927	Battery 12 Volt 35 Amp
2	74760412	Bolt Hex Hd 1/4-20 unc x 3/4
8	7603J	Tray Battery
10	145211	Bolt Btr Frt 1/4-20 x 7.5 Zinc
11	150109	Holddown Battery Mount
12	145769	Nut Push Nylon 1/4" Battery Frt
16	176138	Switch Interlock
21	183759	Harness Asm Light W/4152J
22	4152J	Bulb Light #1156
24	4799J	Cable Battery 6 Ga. 11"red
25	146148	Cable Battery 6 Ga. w/16 ire,red
26	175158	Fuse
27	73510400	Nut Keps Hex 1/4-20 unc
28	145491	Cable Ground 6 Ga. 21" black
29	121305X	Switch Plunger Nc Gray
30	175566	Switch Ign 3
33	140403	Key Ign
40	179720	Harness Ign
41	71110408	Bolt Blk Fin Hex 1/4-20 unc x 1/2
42	131563	Cover Terminal Red
43	178861	Solenoid
45	121433X	Ammeter
52	141940	Protection Wire Loop (Hourmeter)
55	17490508	Screw Thdrol 5/16-18 x 1/2

**NOTE:** All component dimensions give in U.S. inches  
1 inch = 25.4 mm.

# REPAIR PARTS

## TRACTOR - - MODEL NUMBER 944.604010

### CHASSIS AND ENCLOSURES

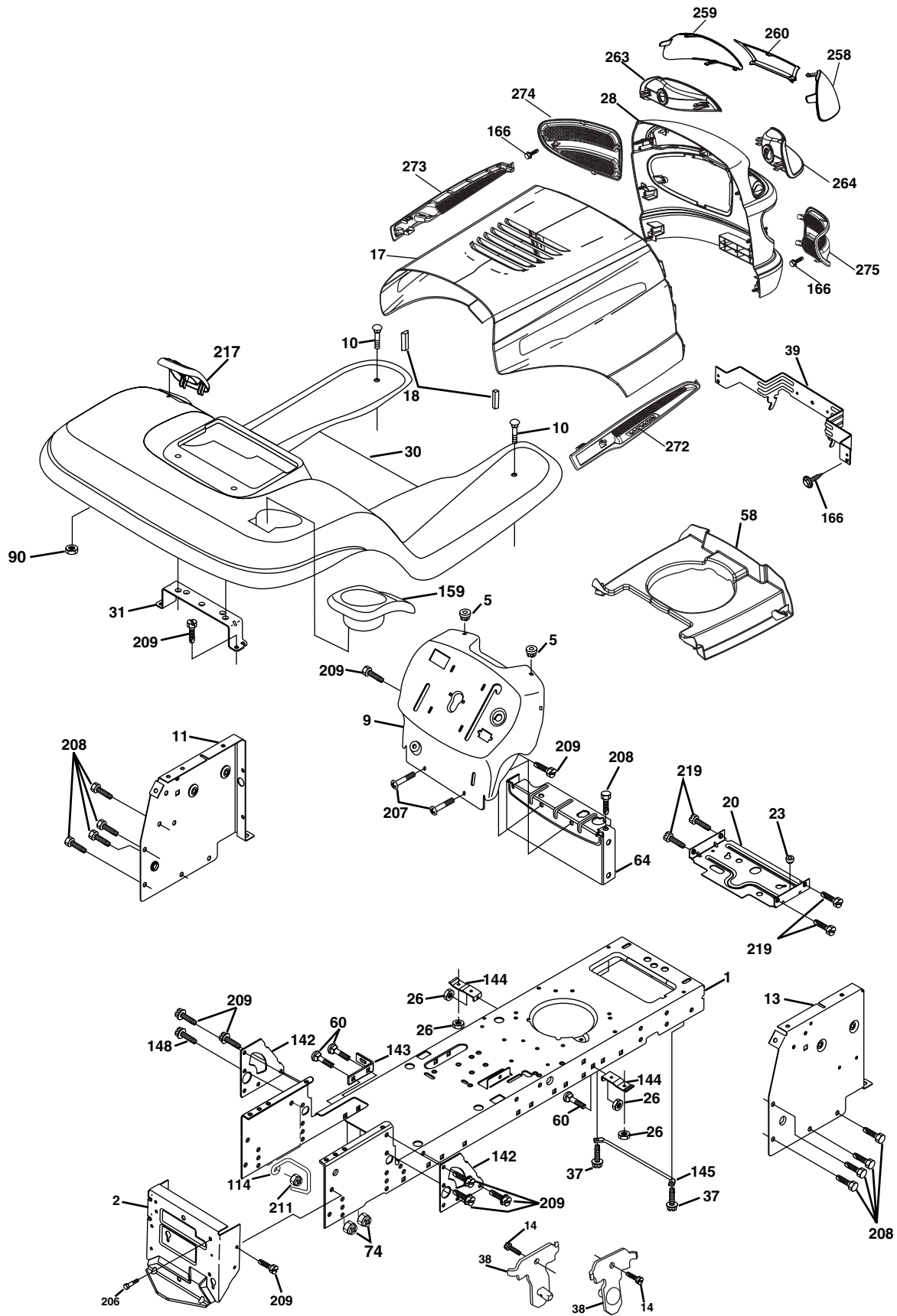

# REPAIR PARTS

## TRACTOR - - MODEL NUMBER 944.604010

### CHASSIS AND ENCLOSURES

KEY NO.	PART NO.	DESCRIPTION
1	174619	Chassis Stl Stamping
2	176554	Drawbar, Stretch
5	155272	Bumper Hood/Dash
9	168337X011	Dash P/L
10	STD533710	Bolt Carriage 3/8-16 x 1
11	174996	Panel Dash Lh
13	172105X010	Panel Dash Rh
14	17490608	Screw Thdrol 3/8-16 x 1/2
17	184272X615	Hood
18	184921	Bumper Extension
20	180679	Plate Mtg. Battery Fuel Tank
23	124028X	Bushing
26	73800600	Nut Lock Hex W/Ins. 3/8-16 unc
28	184259	Grille/Lens Asm (Includes Key nos. 166, 258-260, 263-264, 274-275)
30	179131X615	Fender Footrest STLT
31	139976	Bracket Support Fender
37	17490508	Screw Thdrol 5/16-18 x1/2
38	175710	Bracket Asm. Pivot Mower Rear
39	174714	Bracket Pivot Laser LT
58	187145	Air Duct
60	STD533707	Bolt Rdhd Sqnk 3/8-16 unc x 3/4
64	154798	Dash Lower STLT
74	STD541437	Nut Crownlock 3/8-16 unc
90	124346X	Nut Self-Thd Wsh-Hd 1/4
114	158112	Keeper Belt Rear LH
142	175702	Plate Reinforcement STLT
143	186689	Bracket Swaybar Chassis
144	175582	Bracket Pnt Footrest STLT
145	156524	Rod Pivot Chassis/Hood
148	145212	Nut Hexflange Lock
159	179950X428	Cupholder
166	171875	Screw HWHD Hi-Lo #13-16 x 3/4
206	170165	Bolt Shoulder 5/16-18 TT
207	17670508	Screw Thdrol 5/16-18 x 1/2
208	17670608	Screw Thdrol 3/8-16 x 1/2
209	17000612	Screw Hexwsh Thdr 3/8-16 x 3/4
211	17490620	Screw Thdrol 3/8-16 x 1-1/4
217	179132X428	Console Fuel Window
219	17000512	Screw 5/16-18-3/4
258	184264X599	Lens Laser RH
259	184263X599	Lens Laser LH
260	184262X428	Cover Lens
263	184265	Bezel Grille LH
264	184266	Bezel Grille RH
272	185923X428	Hood Vent RH
273	185922X428	Hood Vent LH
274	184260X428	Insert Grille LH
275	184261X428	Insert Grille RH
- -	5479J	Plug Button

**NOTE:** All component dimensions given in U.S. inches  
1 inch = 25.4 mm





# REPAIR PARTS

## TRACTOR - - MODEL NUMBER 944.604010

### DRIVE

KEY NO.	PART NO.	DESCRIPTION	KEY NO.	PART NO.	DESCRIPTION
1	-----	Transaxle (See Breakdown) Peerless 206-545C	62	8883R	Cover Pedal Blk Round
2	146682	Spring Return Brake T/a Zinc	63	175410	Engine Pulley LT/YT
3	123666X	Pulley Transaxle 18" tires	64	173937	Bolt Hex
4	12000028	Ring Retainer # 5100-62	65	STD55143	Washer Lock Hvy Hlcl Spr 7/16
5	121520X	Strap Torque 30 Degrees	66	154778	Keeper Belt Engine Foolproof
6	17060512	Screw Thdrol 5/16-18 x 3/4 TYT	70	134683	Guide Belt Mower Drive RH
8	165866	Rod Shift Fender Adjust LT	74	137057	Spacer Axle
10	STD561210	Pin Cotter 1/8 x 1 Cad	75	121749X	Washer 25/32 x 1 1/4 x 16 Ga.
11	105701X	Washer Plate Shf 388 Sq Hole	76	STD581075	E-ring #5133-75
13	74550412	Bolt 1/4-28 Unf Gr. 8 W/Patch	77	123583X	Key Square 2 0 x 1845/ 1865
14	10040400	Washer Lock Hvy Helical 1/4	78	121748X	Washer 25/32 x 1-5/8 x 16 Ga.
15	74490544	Bolt Hex 5/16-18 Gr. 5	79	2228M	Key Woodruff
16	STD541431	Nut Lock Hx w/Ins 5/16-18 unc	80	145090	Arm Shift
18	STD523710	Bolt, Fin Hex 3/8-16 unc x 1 Gr. 5	81	165592	Shaft Asm Cross
19	STD541437	Nut Lock 3/8-16 unc	82	165711	Spring Torsion T/a
21	130564	Knob	83	19171216	Washer 17/32 x 3/4 x 16 Ga.
22	130804	Rod Brake Blk Zinc 26 840	84	166231	Link Transaxle
24	STD541237	Nut Hex Jam 3/8-16 unc	85	150360	Nut Lock Center 1/4 - 28 FNTHD
25	106888X	Spring Rod Brake 2 00 Zinc	89	158391X428	Console Shift STLT
26	STD551037	Washer 13/32 x 13/16 x 16 Ga.	90	124346X	Nut Self-thd Wsh-hd 1/4 Zinc
27	STD561210	Pin Cotter 1/8 x 3/4 Cad	96	4497H	Retainer Spring
28	175765	Rod Brake Parking LT/YT	112	19091210	Washer 9/32 x 3/4 x 10 Ga.
29	71673	Cap Brake Parking	113	127285X	Strap Torque LH
30	169592	Bracket Mtg Transaxle	116	72140608	Bolt Rdhd Sq Neck 3/8-16 x 1
32	STD523107	Bolt Hex Hd 5/16-18 unc x 3/4	120	73900600	Nut Lock Flg 3/8-16 unc
34	175578	Shaft Asm Pedal Foot	150	175456	Bushing Retainer
35	120183X	Bearing Nylon Blk 629 Id	151	19133210	Washer 13/32 x 2 x 10
36	STD551062	Washer 21/32 x 1 x 16 Ga.	156	166002	Washer Srrted 5/16 ID x 1 x .125
37	STD571810	Pin Roll 3/16 x 1"	158	165589	Bracket Shift Mount
38	179114	Pulley Idler Flat	159	183900	Hub Shift
39	72110622	Bolt Fin Hex 3/8-16 unc x 2-3/4	161	72140406	Bolt Rdhd Sqnk 1/4-20 x 3/4 Gr. 5
41	175556	Keeper Belt Idler	162	73680400	Nut Crownlock 1/4-20 unc
47	127783	Pulley Idler V Groove Plastic	163	74780416	Bolt Hex Fin 1/4-20 unc x 1 Gr. 5
48	154407	Bellcrank Asm	165	165623	Bracket Pivot Lever
49	123205X	Retainer Belt Style Spring	166	17490510	Screw 5/16-18 x 5/8
50	72110612	Bolt Hex Hd 3/8-16 unc x 1-1/2	168	165492	Bolt Shoulder 5/16-18 x .561
51	STD541437	Nut Crownlock 3/8-16 unc	169	165580	Plate Fastening LT
52	STD541431	Nut Crownlock 5/16-18 unc	170	187414	Keeper Belt Transaxle
53	105710X	Link Clutch	197	169613	Nyliner Snap-In
55	105709X	Spring Return Clutch 6 75	198	169593	Washer Nyliner
56	17060620	Screw 3/8-16 x 1-1/4	202	72110614	Bolt Carriage 3/8-16 x 1-3/4 Gr. 5
57	130801	V-Belt Ground Drive	212	145212	Nut Hexflange Lock
59	169691	Keeper Belt Span Ctr			
61	17120614	Screw 3/8-16 x .875			

**NOTE:** All component dimensions given in U.S. inches  
1 inch = 25.4 mm

# REPAIR PARTS

TRACTOR - - MODEL NUMBER 944.604010

## STEERING ASSEMBLY

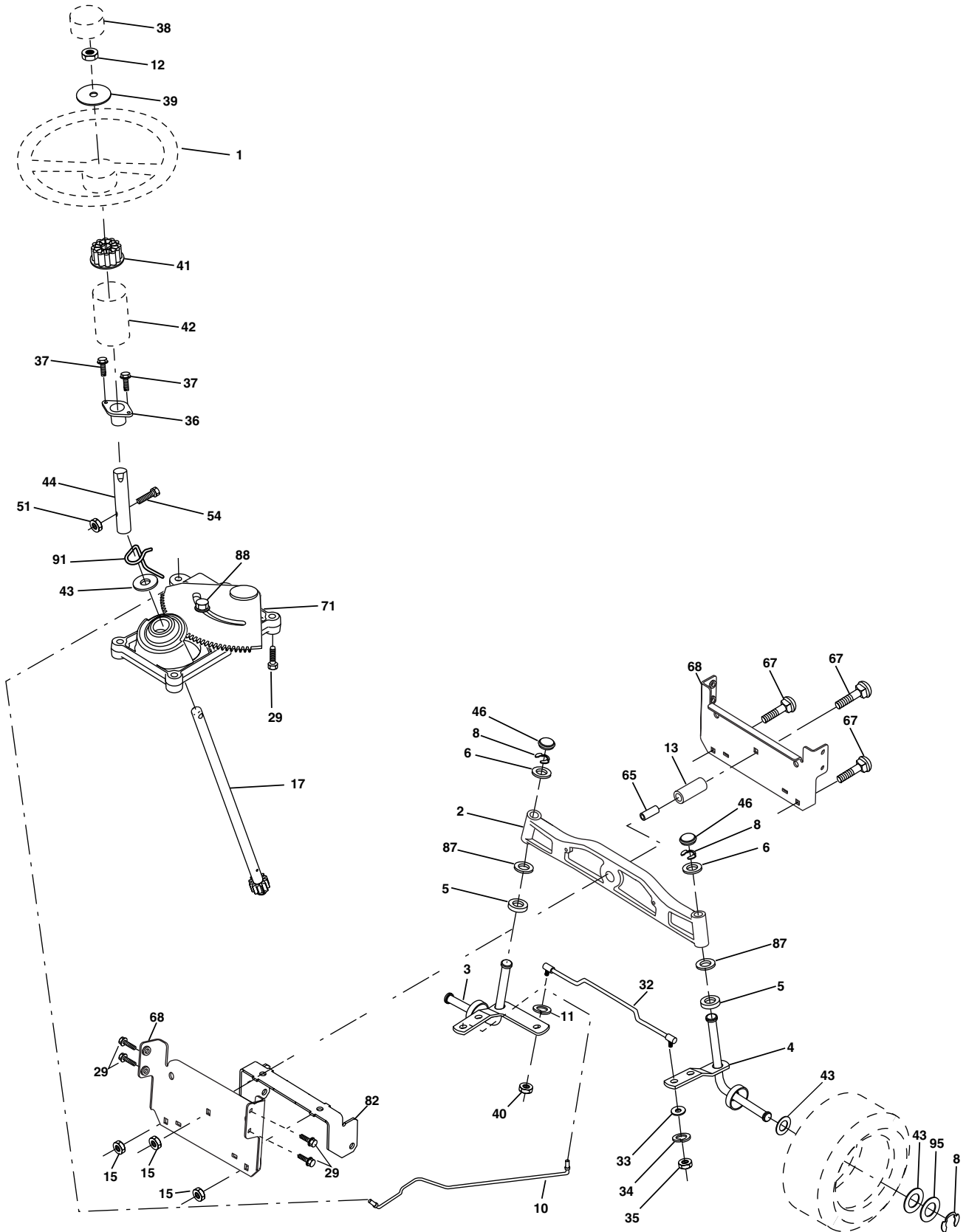

steering\_pl.lt\_29

# REPAIR PARTS

## TRACTOR - - MODEL NUMBER 944.604010

### STEERING ASSEMBLY

KEY NO.	PART NO.	DESCRIPTION
1	159944X428	Wheel Steering
2	184706	Axle Asm
3	169840	Spindle Asm LH
4	169839	Spindle Asm RH
5	6266H	Bearing Race Thrust Harden
6	121748X	Washer 25/32 x 1-5/8 x 16 Ga.
8	12000029	Ring Klip #t5304-75
10	175121	Link Drag Extended Stamp
11	STD551137	Washer Lock Hvy Hlcl Spr 3/8
12	73940800	Nut Hex Jam Toplock 1/2-20 unf
13	136518	Bearing Axle STLT/GT
15	145212	Nut Hex Flange Lock
17	180641	Shaft Asm Strg
29	17000612	Screw Thdrol 3/8-16 x 3/4
32	171888	Rod Tie Wire Form 19 75 Mech
33	19111216	Washer 11/32 x 3/4 x 16
34	10040500	Washer Lock 5/16
35	73540500	Crownlock Nut 5/16-24
36	155099	Bushing Strg
37	152927	Screw
38	159946X428	Insert Cap Strg Wh Au
39	19182411	Washer
40	73540600	Nut Crownlock 3/8-24
41	159945	Adaptor Wheel Strg
42	145054X428	Boot Steering Shaft
43	121749X	Washer 25/32 x 1 1/4 x 16 Ga.
44	180640	Extension Steering Shaft LR/LT
46	184946X505	Cap Spindle Fr Top Red
51	73540400	Nut Crownlock 1/2-28
54	71130420	Bolt Hex 1/4-28 unf x 1-1/4 Ga. 8
65	160367	Spacer Axle
67	72110618	Bolt Rdhd Sq 3/8-16 unc x 2-1/4
68	169827	Axle, Brace
71	175146	Steering Asm
82	169835	Bracket Susp. Chassis Front
87	173966	Washer Flat .781 x 1-1/2 x .14
88	175118	Shoulder Bolt 7/16-20
91	175553	Clip Steering
95	188967	Washer Harden .793 x 1.637 x .060

**NOTE:** All component dimensions given in U.S. inches  
1 inch = 25.4 mm

# REPAIR PARTS

## TRACTOR - - MODEL NUMBER 944.604010

### SEAT ASSEMBLY

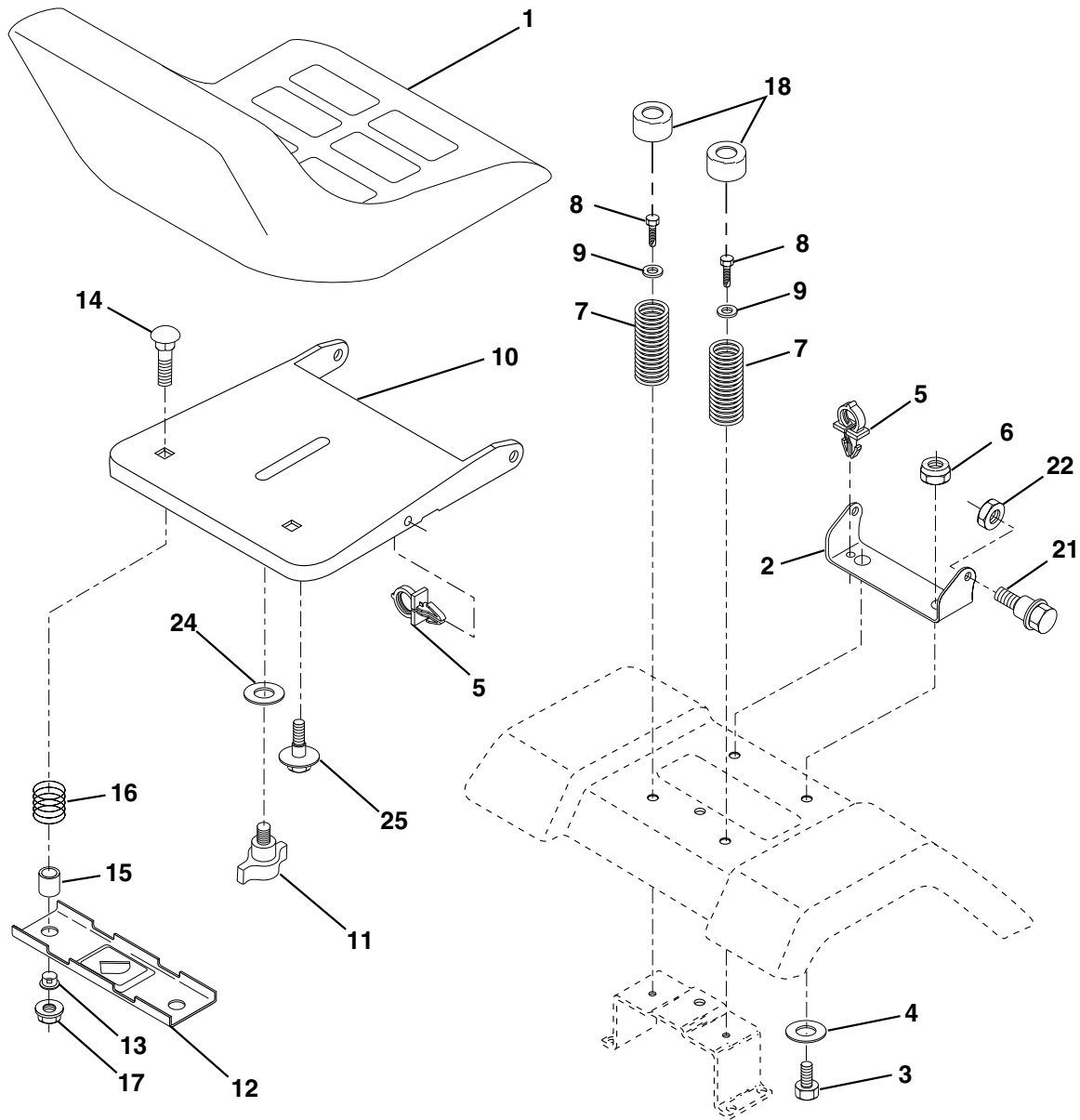

seat\_lt.knob\_2

KEY NO.	PART NO.	DESCRIPTION	KEY NO.	PART NO.	DESCRIPTION
1	188719	Seat	13	121248X	Bushing Snap Blk Nyl 50 Id
2	180166	Bracket Pivot Seat 8 720	14	72050412	Bolt Rdhd Sqnk 1/4-20 x 1-1/2
3	71110616	Bolt Fin Hex 3/8-16 unc x 1	15	134300	Spacer Split 28 x 96 Yel Zinc
4	19131610	Washer 13/32 x 1 x 10 Ga.	16	121250X	Spring Cprsn 1 27 Blk Pnt
5	145006	Clip Push-In	17	123976X	Nut Lock 1/4 Lge Flg Gr. 5 Zinc
6	STD541437	Nut Hex w/Ins. 3/8-16 unc	18	124238X	Cap Spring Seat
7	124181X	Spring Seat Cprsn 2 250 Blk Zi	21	171852	Bolt Shoulder 5/16-18 unc
8	17000616	Screw 3/8-16 x 1-1/2	22	STD541431	Nut Hex Lock W/Ins 5/16-18
9	19131614	Washer 13/32 x 1 x 14 Ga.	24	19171912	Washer 17/32 x 1-3/16 x 12 Ga.
10	180186	Pan Seat	25	127018X	Bolt Shoulder 5/16-18 x 62
11	166369	Knob Seaat 1/2-13 unc Blk			
12	121246X	Bracket Mounting Switch			

**NOTE:** All component dimensions given in U.S. inches  
1 inch = 25.4 mm

# REPAIR PARTS

## TRACTOR -- MODEL NUMBER 944.604010

### DECALS

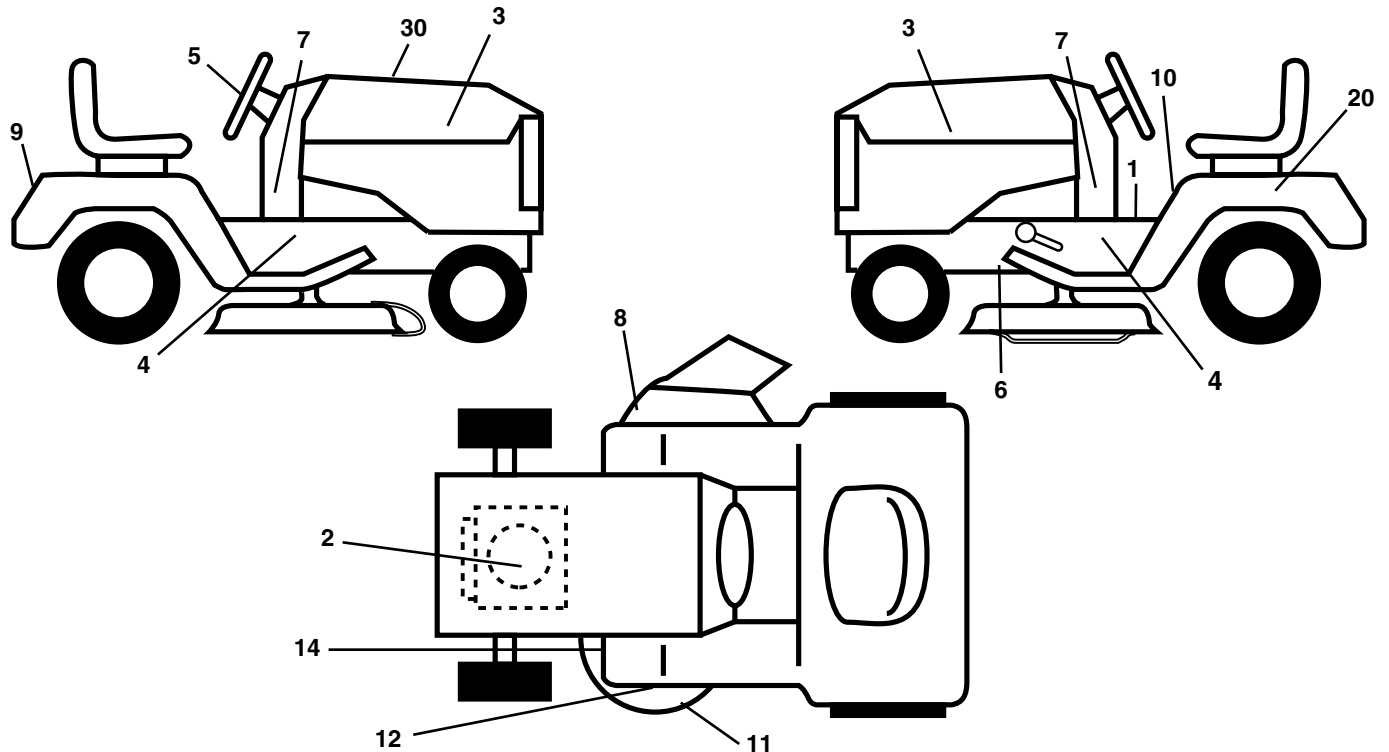

KEY NO.	PART NO.	DESCRIPTION	KEY NO.	PART NO.	DESCRIPTION
1	156369	Decal, Fend STLT Oper.	12	179128	Decal, Mower "B" "42"
2	189102	Decal, Engine	14	160396	Decal, V-Belt Schematic
3	186366	Decal, Hood	20	149517	Decal, Bat Dan/Psn
4	186869	Decal, Chassis BS 22HP	30	190067	Decal, Replacement Parts
5	164065	Decal, Strng Whl	--	138311	Decal, Handle Lft Height Adjust
6	146046	Decal, V-Belt Drive Sch	--	184310X428	Pad, Footrest LH STLT
7	186367	Decal, Lower Dash	--	184311X428	Pad, Footrest RH STLT
8	170563	Decal, Warning	--	190719	Manual, Owner's (English)
9	186572	Decal, Craftsman	--	190720	Manual, Owner's (French)
10	157140	Decal, Fender Danger Eng/Fr			
11	172331	Decal, Deck Heavy Duty			

### WHEELS & TIRES

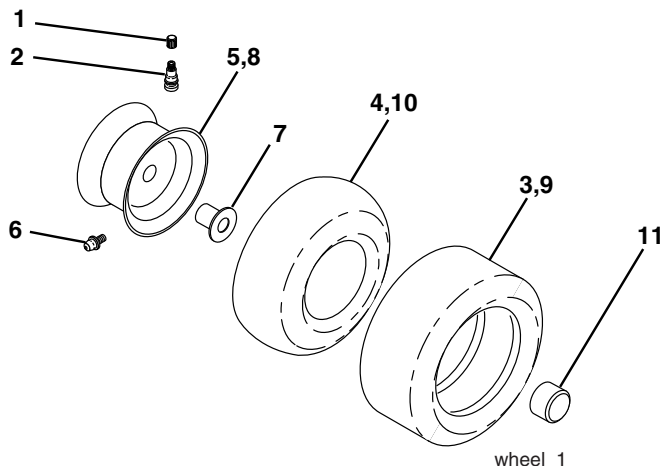

KEY NO.	PART NO.	DESCRIPTION
1	59192	Cap Valve Tire
2	65139	Stem Valve
3	106222X	Tire F Ts 15 x 6 0 - 6 Service
4	59904	Tube Front (Service Item Only)
5	106732X624	Rim Asm 6" front Service
6	278H	Fitting Grease (Front Wheel Only)
7	9040H	Bearing Flange (Front Wheel Only)
8	106108X624	Rim Asm 8" rear Service
9	122082X	Tire R Ts 20 x 10-8 C Service
10	7152J	Tube Rear (Service Item Only)
11	104757X428	Cap Axle Blk 1 50 x 1 00
--	144334	Sealant, Tire ( 10 oz. Tube)

**NOTE:** All component dimensions given in U.S. inches  
1 inch = 25.4 mm

# REPAIR PARTS

TRACTOR - - MODEL NUMBER 944.604010

## ENGINE

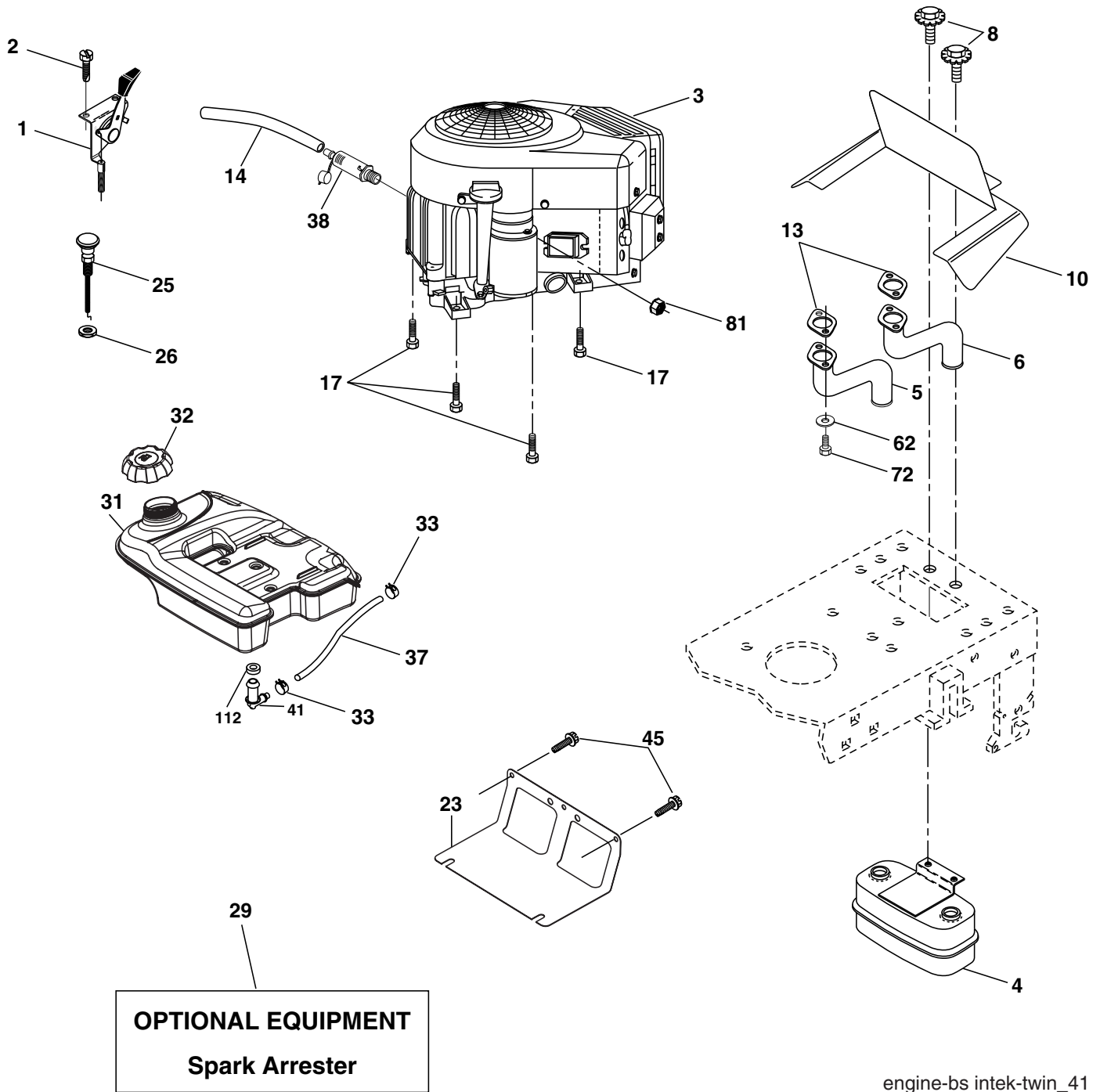

# REPAIR PARTS

## TRACTOR - - MODEL NUMBER 944.604010

### ENGINE

KEY NO.	PART NO.	DESCRIPTION
1	170546	Control Throttle Paddle
2	17720408	Screw Hex Thd Cut 1/4-20 x 5/8 T
3	-----	Engine (See Breakdown) B&S Model 407577-0283-E1
4	149723	Muffler Exhaust
5	159955	Exhaust Asm. Left
6	160589	Exhaust Asm. Right
8	171877	Bolt 5/16-18unc x 3/4
10	162797	Heat Shield Lt
13	165391	Gasket Muffler
14	148456	Tube Drain Oil Easy
17	17060624	Screw Thdrol 3/8-16 x 1-1/2 Tytt
23	169837	Shield BRN/DBR Guard
25	145996	Control Choke
26	73920600	Nut Keps 3/8-24 Unf
29	137180	Arrestor Spark
31	179022	Tank Fuel 4.0
32	179124X428	Cap Fuel Gauge
33	123487X	Clamp Hose Blk
37	8543R	Line Fuel
38	181654	Plug Drain Oil Easy
41	139277	Stem Tank Fuel
45	17000612	Screw Hex Wsh Thdrol 3/8-16 x 3/4
72	183906	Screw Socket Head 5/16-18 x 1
81	73510400	Nut Keps Hex 1/4-20 unc
112	3645J	Bushing

**NOTE:** All component dimensions given in U.S. inches  
1 inch = 25.4 mm

# REPAIR PARTS

TRACTOR - - MODEL NUMBER 944.604010

## MOWER LIFT

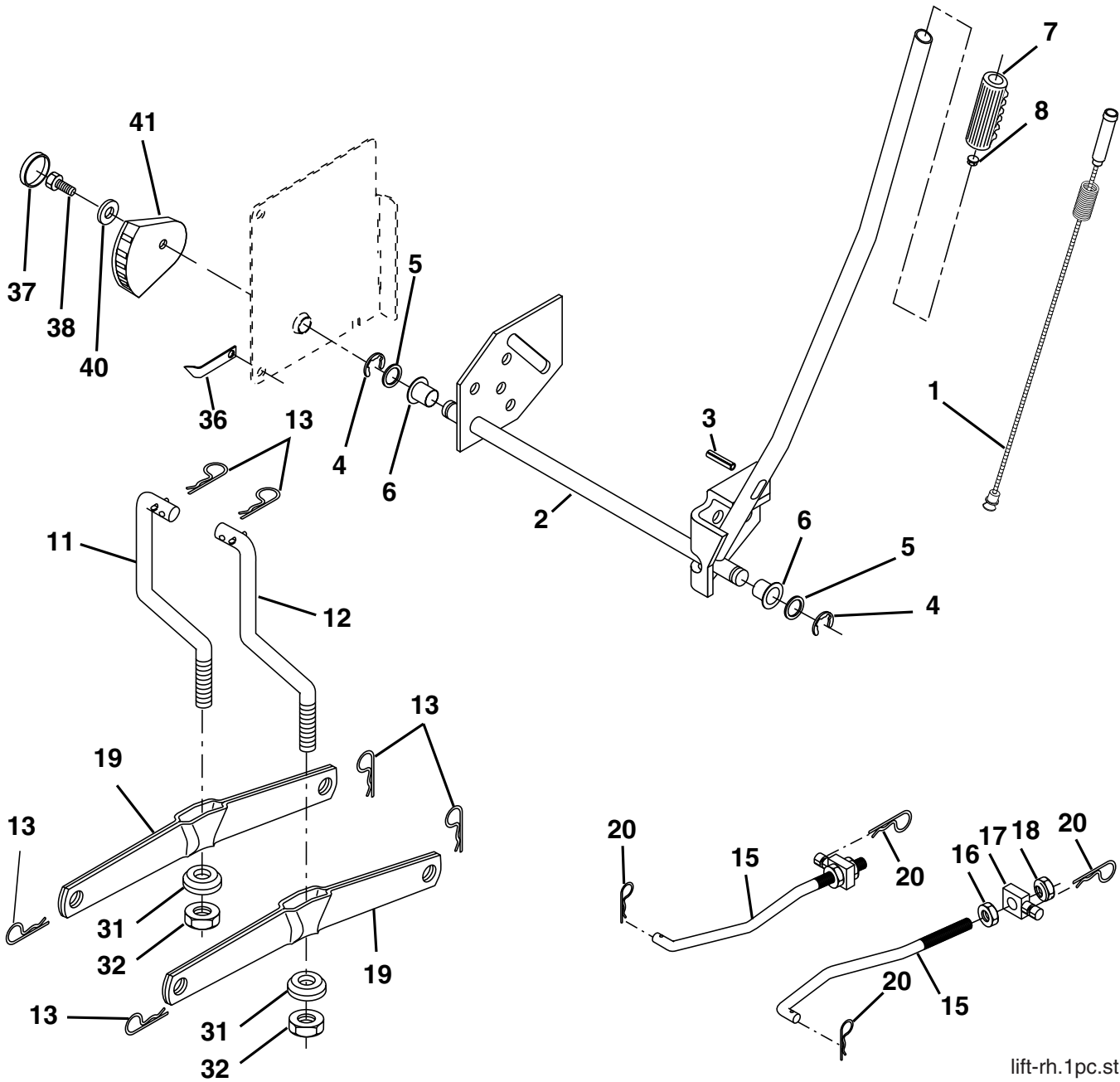

lift-rh.1pc.stlt\_5



# REPAIR PARTS

## TRACTOR - - MODEL NUMBER 944.604010

### MOWER LIFT

KEY NO.	PART NO.	DESCRIPTION
1	159460	Wire Asm Inner W/Plunger
2	159471	Shaft Asm Lift
3	105767X	Pin Groove
4	STD581062	E Ring #5133-62
5	19211621	Washer 29/32 x 1-1/4 x 21 Ga.
6	120183X	Bearing Nylon Blk .629 ID
7	125631X	Grip Handle Fluted
8	122365X	Button, Plunger
11	139865	Link Lift Lh Fixed Length
12	139866	Link Lift Rh Fixed Length
13	STD624008	Retainer Spring
15	173288	Link Front
16	73350800	Nut Jam Hex 1/2-13 unc
17	175689	Trunnion Blk Zinc
18	73800800	Nut Lock w/Wsh 1/2-13 unc
19	139868	Arm Suspension Rear
20	163552	Spring Retainer
31	169865	Bearing Pvt. Lift
32	73540600	Nut Lock 3/8-24
36	155097	Pointer Height Indicator
37	123935X	Plug Hole
38	17060516	Screw 5/16-18 x 1
40	19112410	Washer 11/32 x 1-1/2 x 10 Ga.
41	155098	Indicator Height

**NOTE:** All component dimensions given in U.S. inches  
1 inch = 25.4 mm

# REPAIR PARTS

## TRACTOR - - MODEL NUMBER 944.604010

### MOWER DECK

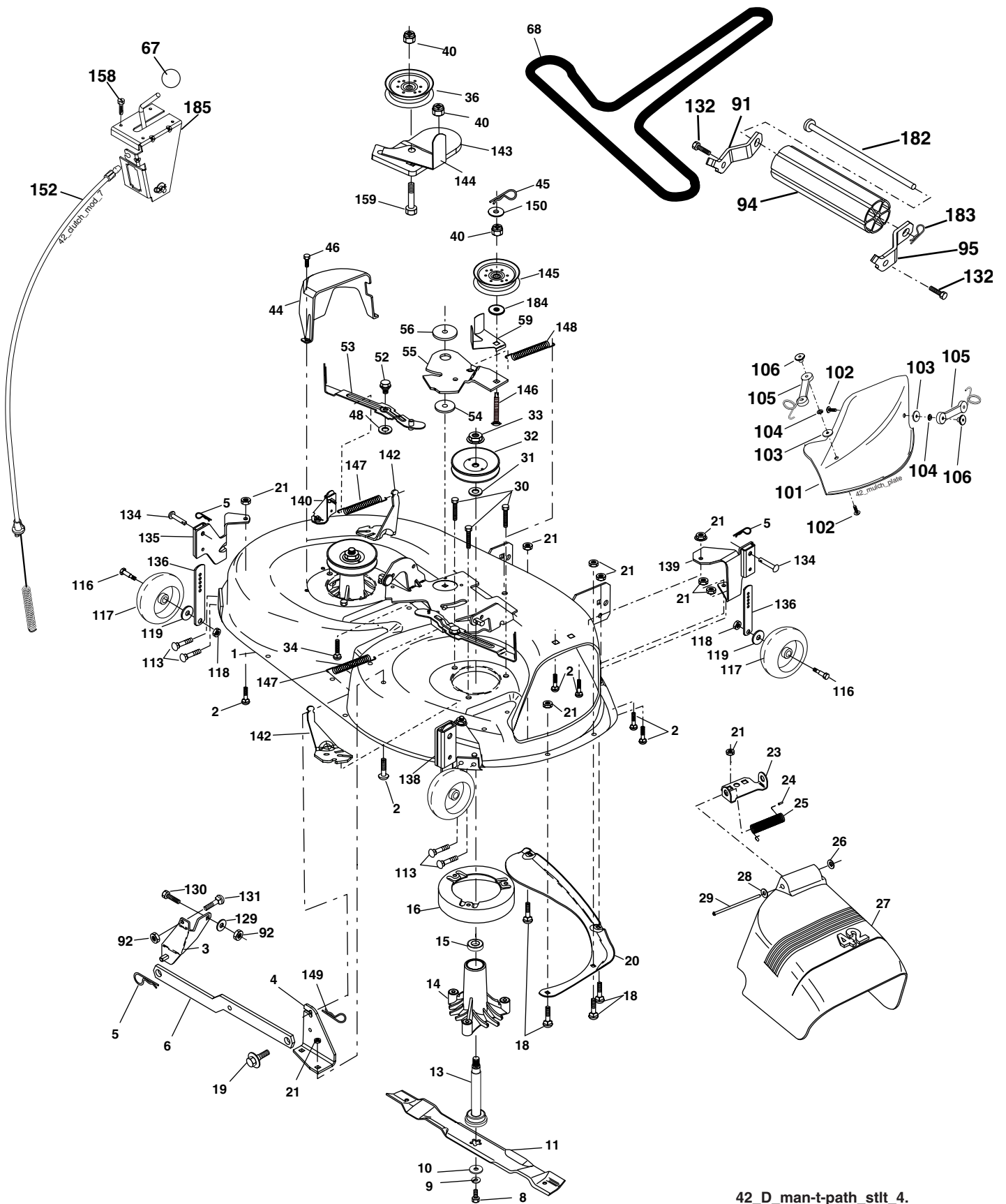

42\_D\_man-t-path\_stilt\_4.

# REPAIR PARTS

## TRACTOR - - MODEL NUMBER 944.604010

### MOWER DECK

KEY NO.	PART NO.	DESCRIPTION	KEY NO.	PART NO.	DESCRIPTION
1	182032	Mower Deck Assembly, 42"	91	180532	Bracket Roller Nose LH
2	STD533107	Bolt	92	STD541437	Nut
3	138017	Bracket Assembly, Sway Bar, Front	94	132264	Roller Nose
4	165460	Bracket Sway Bar 38/42" Deck	95	180533	Bracket Roller Nose RH
5	STD624008	Retainer Spring	101	136420	Mulcher Cover
6	178024	Bar Sway Deck	102	71081010	Screw
8	850857	Bolt, Hex 3/8-24 x 1.25 Gr. 8	103	19061216	Washer #10
9	STD551137	Washer, Lock	104	STD551110	Washer, Lock
10	140296	Washer, Hardened (The following blades are available)	105	160793	Latch Assembly, Bagger
11	134149	Blade, 42" Mulching Std (For mulching mowers only)	106	2029J	Nut, Weld
--	139775	Blade, 42" Mulching Premium (For better wear when mulching)	113	17060512	Screw 5/16-18 x 3/4
--	138971	Blade, 42" Hi-Lift (For bagging or discharging)	116	184219	Bolt, Shoulder
13	137645	Shaft Assembly, Mandrel, Vented	117	174873	Wheel, Gauge
14	128774	Housing, Mandrel, Vented	118	73930600	Nut, Centerlock 3/8-16
15	110485X	Bearing, Ball, Mandrel	119	STD551037	Washer 3/8 x 7/8 x 14 Ga.
16	174493	Stripper, Vented Mower Deck	129	19131312	Washer 13/32 x 13/16 x 12 Ga.
18	72140505	Bolt, Carriage 5/16-18 x 5/8	130	STD523710	Bolt, Fin Hex 3/8-16 unc x 1 Gr. 5
19	132827	Bolt, Shoulder	131	STD533710	Bolt, Rdhd Sqnc 3/8-16 unc x 1
20	159770	Baffle, Vortex	132	17000612	Screw Hexwsh Thdr 3/8-16 x 3/4
21	STD541431	Nut Crownlock 5/16-18 unc	134	156941	Pin Head Rivet
23	177563	Bracket, Deflector	135	159765	Bracket, Gauge, Wheel L.H. Rear
24	105304X	Cap, Sleeve	136	155986	Bar Adjusting Gauge Whl
25	123713X	Spring, Torsion, Deflector	138	159763	Bracket Asm Whl. Ga. Rear RH
26	110452X	Nut, Push	139	159767	Bracket, Gauge, Wheel R.H. Front
27	130968X428	Shield, Deflector	140	159768	Bracket Asm. Whl. Ga. Front LH
28	19111016	Washer 11/32 x 5/8 x 16 Ga.	142	165890	Arm Spring Brake Mower
29	131491	Rod, Hinge	143	157109	Bracket Arm Idler 42"
30	173984	Screw Thdrol Washer Head	144	158634	Keeper Belt 42" Clutch Cable
31	187690	Washer, Spacer	145	165888	Pulley Idler Flat
32	153535	Pulley, Mandrel	146	171977	Bolt Carriage Idler
33	178342	Nut, Toplock, Flanged	147	131335	Spring Extension
34	72110612	Bolt Carr. Sh 3/8-16 x 1-1/2 Gr. 5	148	169022	Spring Return Idler
36	131494	Pulley, Idler, Flat	149	165898	Retainer Spring Yellow Zinc
40	73900600	Nut Lock Flg 3/8-16 unc	150	19091210	Washer 9/32 x 3/4 x 10 Ga.
44	140088	Guard, Mandrel, L.H.	152	169676	Cable Clutch 42 In
45	STD624003	Retainer	158	17720408	Screw Hex Thd Cut 1/4-20 x 5/8
46	137729	Screw, Thd. Roll 1/4-20 x 5/8	159	72140614	Bolt Rdhd Sqnc 3/8-16 unc x 1-3/4
48	133944	Washer, Hardened	182	179126	Rod Roller Nose
52	139888	Bolt, Shoulder 5/16-18 unc	183	163552	Retainer Spring
53	184907	Arm Assembly, Pad, Brake	184	19131410	Washer 13/32 x 7/8 x 10 Ga.
54	178515	Washer, Hardened	185	188234	Head Asm. Cable Clutch
55	155046	Arm, Idler	--	130794	Mandrel Assembly (Includes Housing, Shaft and Shaft Hardware Only - Pulley Not Included)
56	165723	Spacer, Retainer	--	186917	Replacement Mower Complete (Std. Deck-Order separately mulcher cover, nose roller, and gauge wheel components key nos. 101 - 106, 91, 94, 95, 132, 182, 183 and 116 - 119, )
59	141043	Guard, TUV Idler			
67	149846	Knob Custom Oval Blk			
68	144959	V-Belt			

**NOTE:** All component dimensions given in U.S. inches  
1 inch = 25.4 mm

# REPAIR PARTS

TRACTOR - - MODEL NUMBER 944.604010

PEERLESS GEAR TRANSAXLE - MODEL NUMBER 206-545C

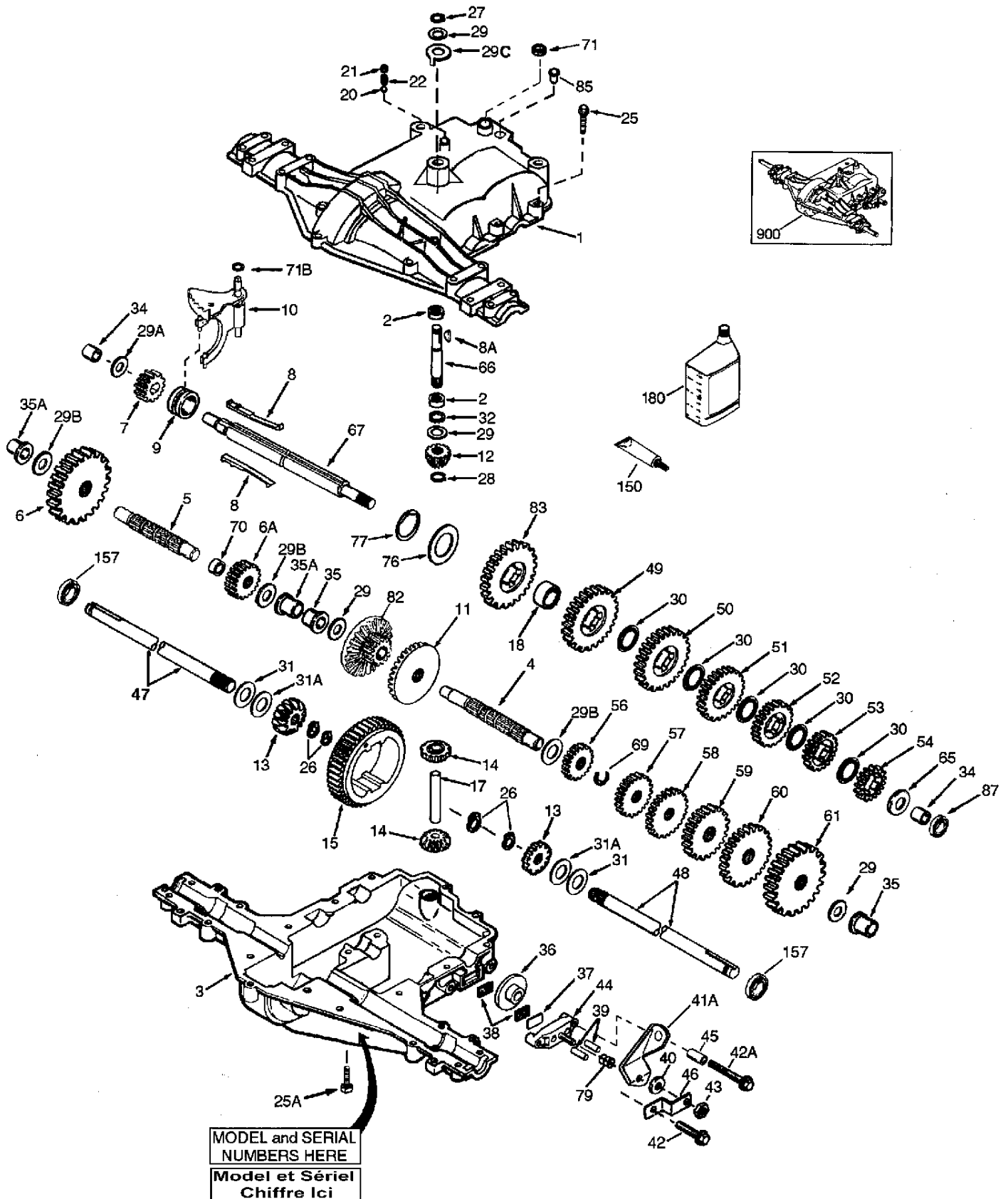

# REPAIR PARTS

## TRACTOR - - MODEL NUMBER 944.604010

### PEERLESS GEAR TRANSAXLE - MODEL NUMBER 206-545C

REF NO.	PART NO.	DESCRIPTION	REF NO.	PART NO.	DESCRIPTION
1	772147	Transaxle Cover	41A	790079	Brake Lever
2	780086A	Needle Bearing 5/8"	42	792073A	Screw 1/4 - 20 x 1-1 /4"
3	770128	Transaxle Case	42A	792085A	Screw 1/4 - 20 x 2 1/4"
4	776395	Countershaft	43	792075	Locknut 5 / 16 - 24
5	776409	Output Shaft	44	790025	Brake Pad Holder
6	778364	Spur Gear (38 teeth)	45	786066	Spacer .2625 x 1.0
6A	778369	Spur Gear (15 teeth)	46	786086	Brake Lever Bracket
7	778330	Spur Gear (11 teeth)	47	774690	Axle (11-15 / 16" Long)
8	792180	Shift Key	48	774691	Axle (16 - 1 / 2" long)
8A	792047	Woodruff Key #9	49	778356	Spur Gear (29 teeth)
9	784352	Shift Collar	50	778338	Spur Gear (27 teeth)
10	784378	Shift Rod & Fork	51	778354	Spur Gear (23 teeth)
11	778334	Bevel Gear (30 teeth)	52	778352	Spur Gear (19 teeth)
12	778309	Input Bevel Pinion (13 teeth)	53	778350	Spur Gear (16 teeth)
13	778368	Bevel Gear (13 teeth) (Include. 14)	54	778346	Spur Gear (15 teeth)
14	778368	Bevel Pinion (13 teeth) (Include. 13)	56	778355	Spur Gear (11 teeth)
15	778370	Ring Gear (43 teeth)	57	778337	Spur Gear (13 teeth)
17	786188	Drive Pin	58	778353	Spur Gear (17 teeth)
18	786102	Spacer 1.130 X .695	59	778351	Spur Gear (21 teeth)
20	792077A	Ball 5/16" dia	60	778349	Spur Gear (24 teeth)
21	792078	Set Screw 3/8 - 16 x 3/8"	61	778345	Spur Gear (25 teeth)
22	792079	Spring .310 OD x .625 L	65	780189	Flat Washer .563 ID x .062W
25	792073A	Screw 1/4 - 20 x 1-1/4"	66	776422	Input Shaft
25A	792177	Screw 1/4-20 x 1-3/8"	67	776396	Shifter & Brake Shaft
26	792125	Retaining Ring (pkg of 2)	69	792170	Retaining Ring
27	792035	Retaining Ring	70	786187	Spacer .890
28	788040	Retaining Ring	71	788069	Square Cut Ring
29	780072	Thrust Washer .627 ID x .031W	71B	788092	"O" Ring
29A	780160	Thrust Washer .762 ID x .031W	76	780090	Flat Washer 1.128 ID x .058W
29B	780051	Thrust Washer .762 ID x .031W	77	788078A	Inverted Retaining Ring
29C	780199	Anti-Rotation Washer .632	79	792144	Spring .430 OD x .5000 L
30	780108	Cup Washer 1.127 ID x .032W	82	778333	Bevel & Spur Gear (30 & 13 teeth)
31	780001	Flat Washer .750 ID x .056W (Use As Needed)	83	778338	Spur Gear (27 teeth)
31A	780195	Flat Washer .750 ID x .062W	85	792154	Oil Fill Plug
32	788083	Oil Seal 5/8"	87	788089A	Oil Seal 9 / 16"
34	780194	Bushing .563	150	788093A	Liquid Gasket RTV Silicone
35	780193	Flanged Bushing 5 / 8" ID	157	788088A	Oil Seal 3 / 4"
35A	780197	Flanged Bushing .751	180	730229A	Gear Oil 80W90
36	790075	Brake Disk	900	794712	Replacement MST - 206-545C Transaxle
37	790007	Brake Pad Plate			
38	799021	Brake Pad (pkg of 2)			
39	786026	Dowel Pin			
40	792076A	Flat Washer .312 ID x .059W			

**NOTE:** All component dimensions given in U.S. inches  
1 inch = 25.4 mm

# REPAIR PARTS

## TRACTOR -- MODEL NUMBER 944.604010

### BRIGGS & STRATTON ENGINE - MODEL NUMBER 407577, TYPE NUMBER 0283-E1

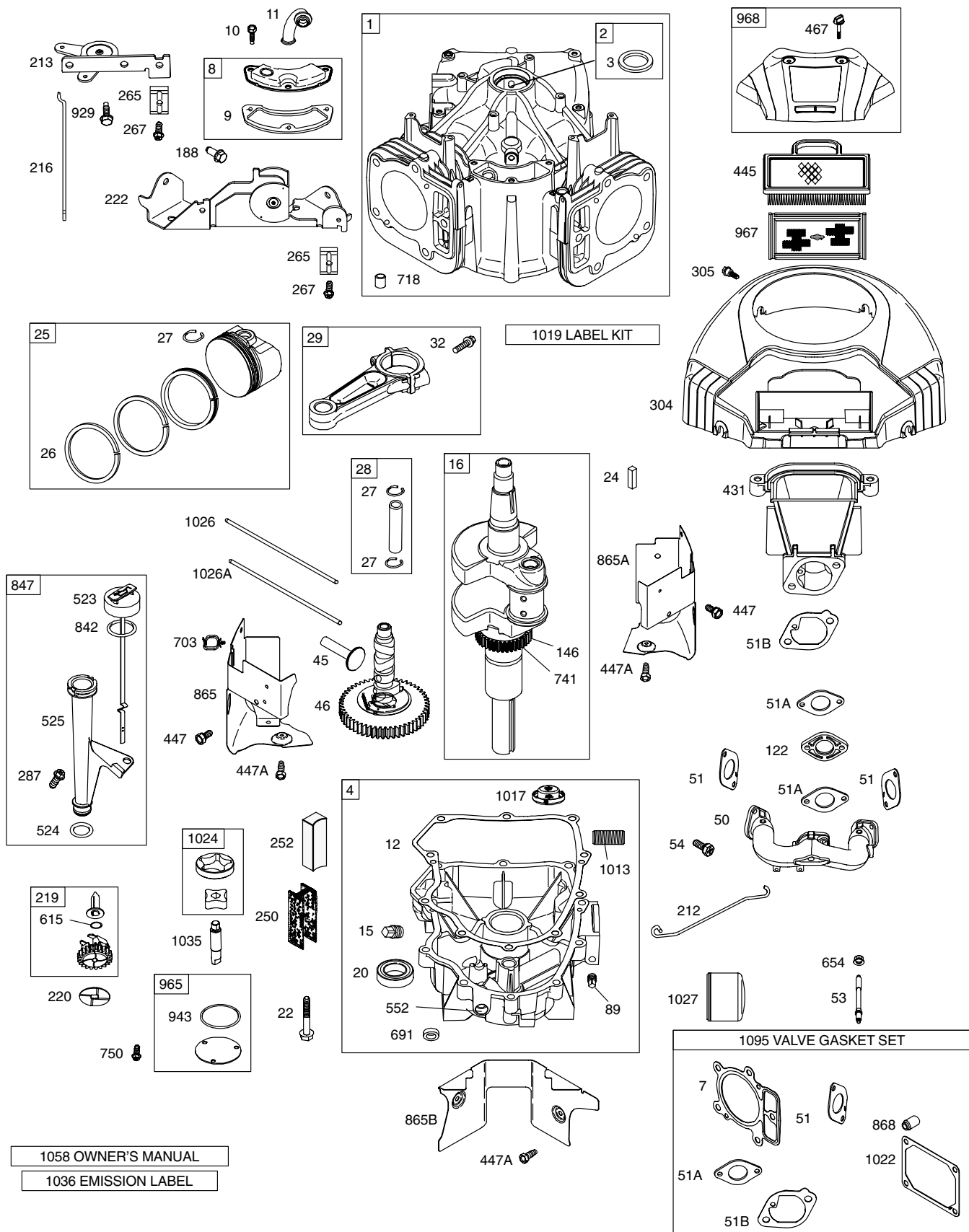

# REPAIR PARTS

## TRACTOR - - MODEL NUMBER 944.604010

### BRIGGS & STRATTON ENGINE - MODEL NUMBER 407577, TYPE NUMBER 0283-E1

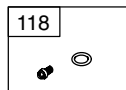
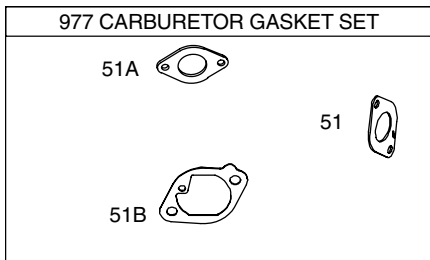
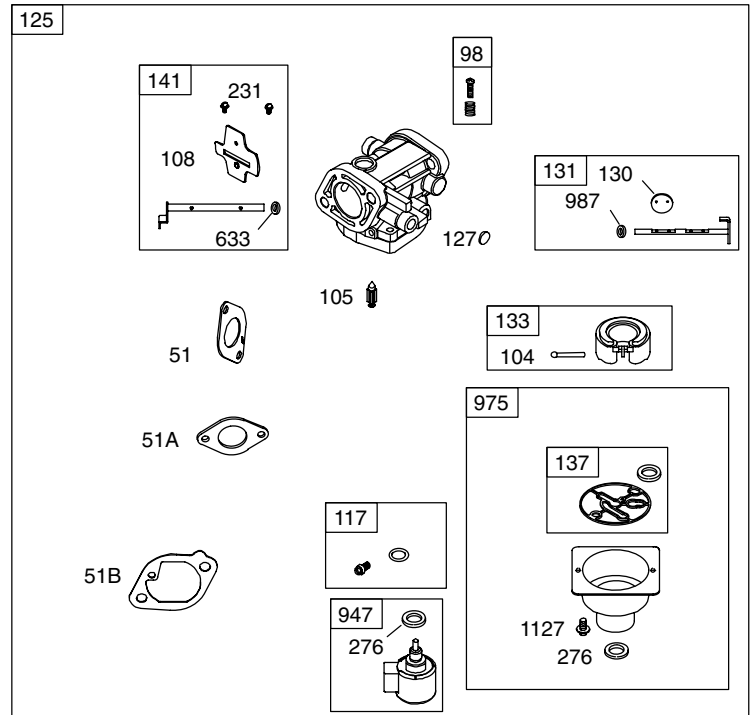
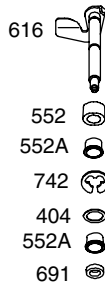
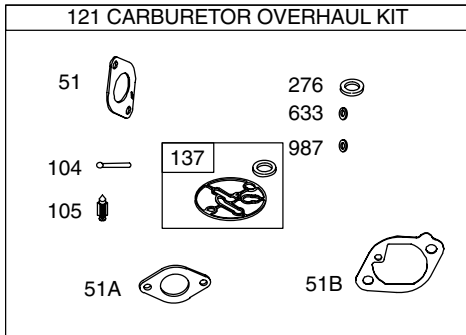
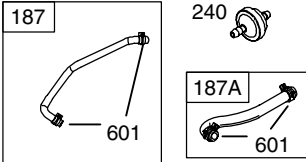
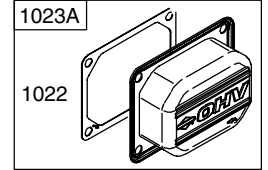
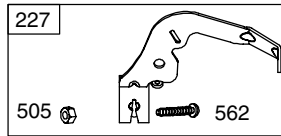
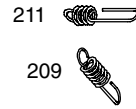
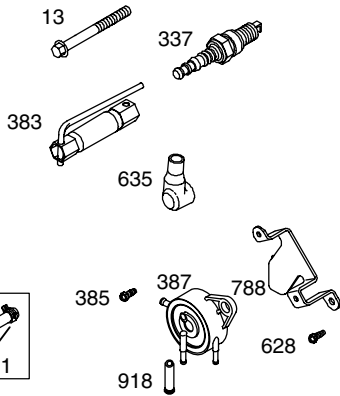
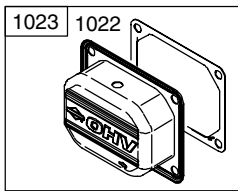
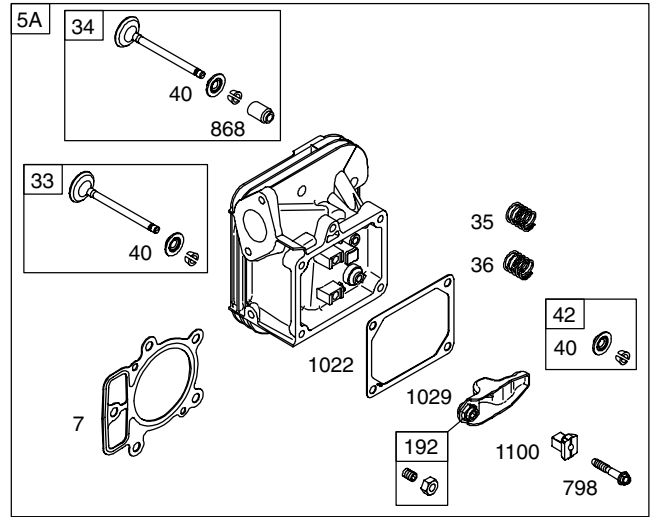
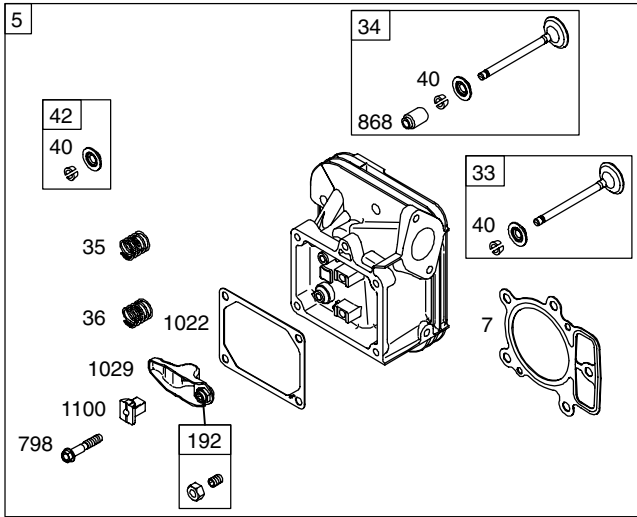

# REPAIR PARTS

TRACTOR - - MODEL NUMBER 944.604010

BRIGGS & STRATTON ENGINE - MODEL NUMBER 407577, TYPE NUMBER 0283-E1

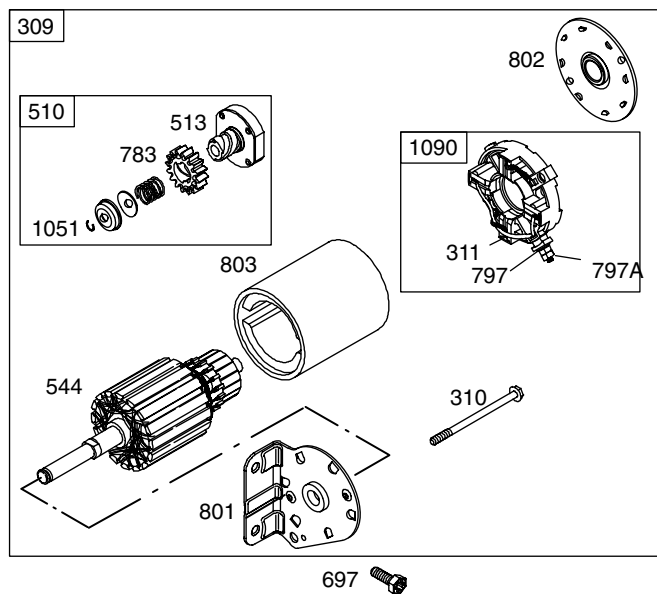
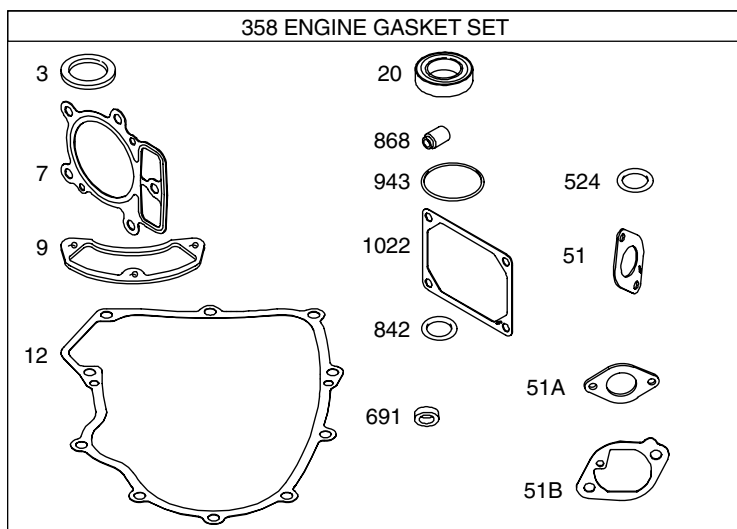
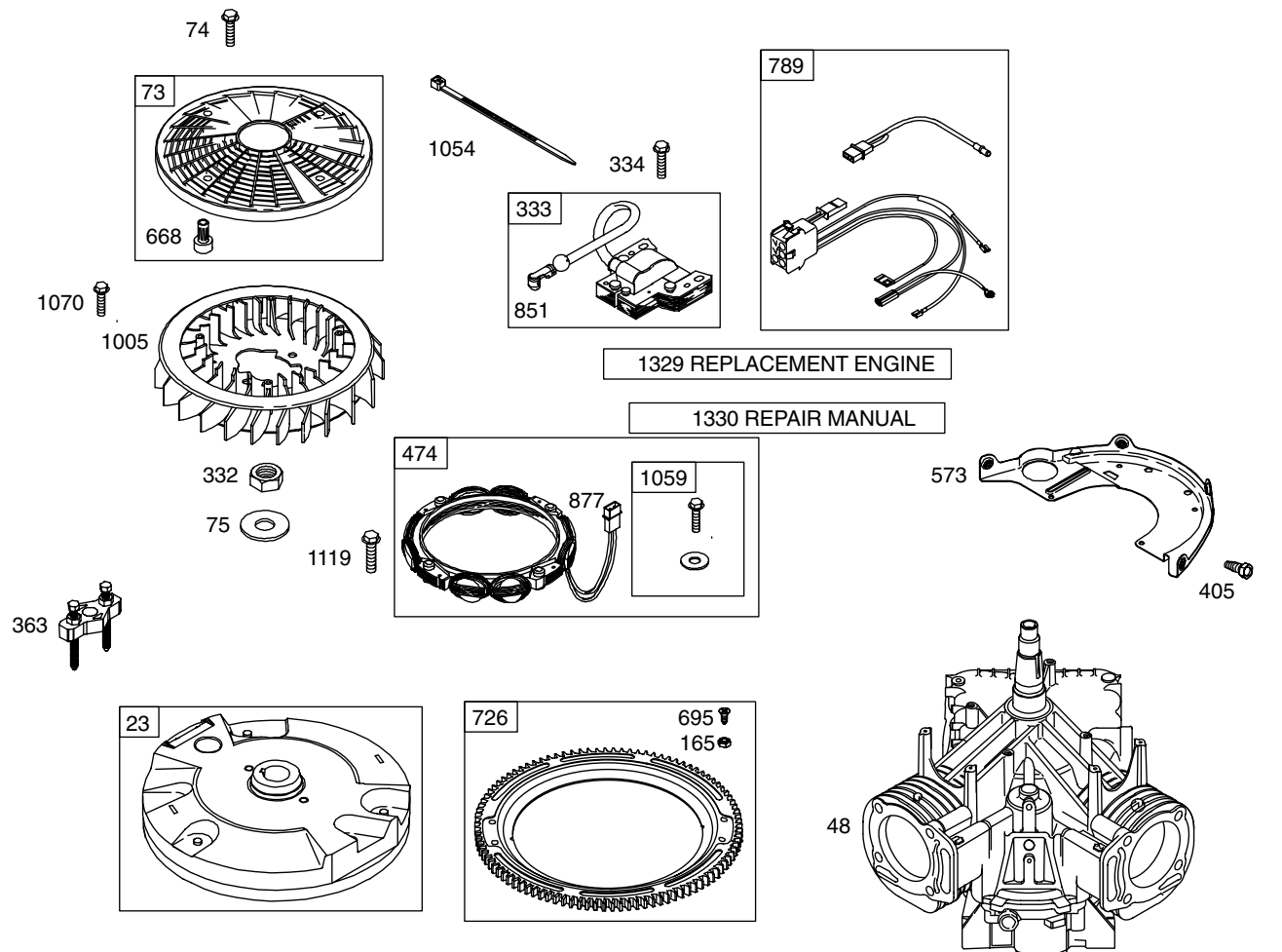



# REPAIR PARTS

## TRACTOR - - MODEL NUMBER 944.604010

### BRIGGS & STRATTON ENGINE - MODEL NUMBER 407577, TYPE NUMBER 0283-E1

KEY NO.	PART NO.	DESCRIPTION	KEY NO.	PART NO.	DESCRIPTION
1	699751	Cylinder Assembly	130	699809	Valve-Throttle
2	499585	Kit-Bushing/Seal (Magneto Side)	131	699812	Kit-Throttle Shaft
3	391086	• Seal-Oil (Magneto Side)	133	694914	Floater-Carburetor
4	699747	Sump-Engine	137	698781	∅ Gasket-Float Bowl
5	693998	Head-Cylinder (Cylinder 1)	141	699811	Kit-Choke Shaft
5A	693999	Head-Cylinder (Cylinder 2)	146	690979	Key-Timing
7	690962	•+ Gasket-Cylinder Head	165	693148	Nut (Ring Gear)
8	499601	Breather Assembly	187	699799	Line-Fuel
9	690937	• Gasket-Breather	187A	691049	Line-Fuel (Molded)
10	690960	Screw (Breather Assembly)	188	690960	Screw (Control Bracket)
11	690942	Tube-Breather	192	690083	Adjuster-Rocker Arm
12	697227	• Gasket-Crankcase	209	692909	Spring-Governor
13	690360	Screw (Cylinder Head)	211	691019	Spring-Governed Idle
15	690946	Plug-Oil Drain	212	699805	Link-Throttle
16	691046	Crankshaft	213	691021	Bracket-Choke Control
20	690947	• Seal-Oil (PTO Side)	216	691022	Link-Choke
22	694966	Screw (Engine Sump)	219	698231	Gear-Governor
23	691054	Flywheel	220	690412	Washer (Governor Lever)
24	222698	Key-Flywheel	222	698761	Bracket-Control
25	499588	Piston Assembly (Standard)	227	691048	Lever-Governor Control
25	499590	Piston Assembly (.020" Oversize)	231	690718	Screw (Choke Valve)
26	499604	Ring Set-Piston (Standard)	240	691035	Filter-Fuel
26	499606	Ring Set-Piston (.020" Oversize)	250	690957	Retainer-Breather
27	690975	Lock-Piston Pin	252	690956	Collector-Oil
28	690229	Pin-Piston	265	691024	Clamp-Casing
29	499583	Rod-Connecting	267	695134	Screw (Casing Clamp)
32	690976	Screw (Connecting Rod)	276	695410	+ Washer-Sealing
33	499596	Valve-Exhaust	287	690960	Screw (Dipstick Tube)
34	499597	Valve-Intake	304	695277	Housing-Blower
35	690963	Spring-Valve (Intake)	305	691005	Screw (Blower Housing)
36	690963	Spring-Valve (Exhaust)	309	497595	Motor-Starter
40	690964	Retainer-Valve	310	690323	Bolt (Starter Motor)
42	499586	Keeper-Valve	311	497608	Brush Set
45	690977	Tappet-Valve	332	691059	Nut (Flywheel)
46	699748	Camshaft	333	691060	Armature-Magneto
48	692714	Short Block	334	691061	Screw (Magneto Armature)
50	699801	Manifold-Intake	337	691043	Spark Plug
51	690949+• ∅‡	Gasket-Intake	358	699823	Set-Engine Gasket
51A	699803+• ∅‡	Gasket-Intake	363	691062	Flywheel Puller
51B	699800+• ∅‡	Gasket-Intake	383	690966	Wrench-Spark Plug
53	690951	Stud (Carburetor)	385	690960	Screw (Fuel Pump)
54	699816	Screw (Intake Manifold)	387	808656	Pump-Fuel
73	691055	Screen-Rotating	404	690442	Washer (Governor Crank)
74	691057	Screw (Rotating Screen)	405	697820	Screw (Back Plate)
75	691056	Washer (Flywheel)	431	699806	Elbow-Intake
89	690283	Plug-Oil	445	499486	Filter-Air Cleaner Cartridge
98	699721	Kit-Idle Speed	447	691003	Screw (Air Guide Cover)
104	694918	∅ Pin-Float Hinge	447A	690960	Screw (Air Guide Cover)
105	698537	∅ Valve-Float Needle			
108	699808	Valve-Choke			
117	698784	Jet-Main (Standard)	•		Included in Engine Gasket Set, Key. No. 358
118	699820	Jet-Main (High Altitude)	∅		Included in Carburetor Overhaul Kit, Key. No. 121
121	699814	Kit-Carburetor Overhaul	‡		Included in Carburetor Gasket Set, Key. No. 977
122	699802	Spacer-Carburetor	+		Included in Valve Gasket Set, Key. No. 1095
125	699807	Carburetor			
127	699810	Plug-Welch			

**NOTE:** All component dimensions given in U.S. inches 1 inch = 25.4 mm

# REPAIR PARTS

## TRACTOR - - MODEL NUMBER 944.604010

### BRIGGS & STRATTON ENGINE - MODEL NUMBER 407577, TYPE NUMBER 0283-E1

KEY NO.	PART NO.	DESCRIPTION	KEY NO.	PART NO.	DESCRIPTION
467	691008	Knob-Air Cleaner	877	393456	Wire/Connector-Alternator
474	696459	Alternator	914	691127	Screw (Rocker Cover)
505	691029	Nut (Governor Control Lever)	918	694000	Hose-Vacuum
510	497606	Drive-Starter	929	691003	Screw (Choke Control Bracket)
513	692024	Clutch-Drive	943	690589	• Seal-O Ring (Oil Pump Cover)
523	691036	Dipstick	947	699728	Solenoid-Fuel
524	691032	• Seal-Dipstick Tube	965	499613	Cover-Oil Pump
525	691037	Tube-Dipstick	967	273638	Filter-Pre Cleaner
544	692034	Armature-Starter	968	499788	Cover-Air Cleaner
552	690552	Bushing-Governor Crank	975	699502	Bowl-Float
552A	690553	Bushing-Governor Crank	977	699815	Gasket Set-Carburetor
562	690311	Bolt (Governor Control Lever)	987	699813	Ø Seal-Throttle Shaft
573	691009	Plate-Back	1005	499603	Fan-Flywheel
601	95162	Clamp-Hose	1013	690954	Nipple-Oil Filter
615	698290	Retainer-Governor Shaft	1017	690770	Screen-Oil Pump
616	691045	Crank-Governor	1019	690103	Kit-Label
628	690960	Screw (Fuel Pump Bracket)	1022	690971	•+ Gasket-Rocker Cover
633	695414	Ø Seal-Choke/Throttle Shaft	1023	499599	Cover-Rocker (Cylinder 1)
635	66538	Boot-Spark Plug	1023A	499600	Cover-Rocker (Cylinder 2)
654	690958	Nut (Carburetor)	1024	499054	Pump-Oil
668	691215	Spacer	1026	690981	Rod-Push (Steel)
691	690657	• Seal-Governor Shaft	1026A	690982	Rod-Push (Aluminum)
695	693149	Screw (Ring Gear)	1027	492932	Filter-Oil
697	690372	Screw (Drive Cap)	1029	690972	Arm-Rocker
703	691010	Clip	1035	691042	Shaft-Pump
718	690959	Pin-Locating	1036	695704	Label-Emission
726	499612	Gear-Ring	1051	691265	Ring-Retaining
741	690980	Gear-Timing	1054	280275	Cable-Tie
742	690328	Retainer-E Ring	1058	275475	Owner's Manual
750	696999	Screw (Oil Pump Cover)	1059	698516	Kit-Screw/Washer
783	693058	Gear-Pinion	1070	691674	Screw (Flywheel Fan)
788	691039	Bracket-Fuel Pump	1090	691293	Retainer-Brush
789	698330	Harness-Wiring	1095	699822	Gasket Set-Valve
797	691029	Nut (Brush Retainer)	1100	690973	Pivot-Rocker Arm
797A	693167	Nut (Brush Retainer)	1119	691183	Screw (Alternator)
798	697890	Screw (Rocker Arm)	1127	695407	Screw (Float Bowl)
801	691283	Cap-Drive	1329	407577-0025	Replacement Engine
802	691286	Cap-End	1330	273521	Repair Manual
803	693757	Housing-Starter			
842	691031	• Seal-Dipstick/Tube	•		Included in Engine Gasket Set, Key. No. 358
847	499602	Dipstick/Tube Assembly	Ø		Included in Carburetor Overhaul Kit, Key. No. 121
851	493880	Terminal-Spark Plug	‡		Included in Carburetor Gasket Set, Key. No. 977
865	691012	Cover-Air Guide	+		Included in Valve Gasket Set, Key. No. 1095
865A	691014	Cover-Air Guide			
865B	691015	Cover-Air Guide			
868	690968	•+ Seal-Valve			

**NOTE:** All component dimensions given in U.S. inches 1 inch = 25.4 mm

# SUGGESTED GUIDE FOR SIGHTING SLOPES FOR SAFE OPERATION

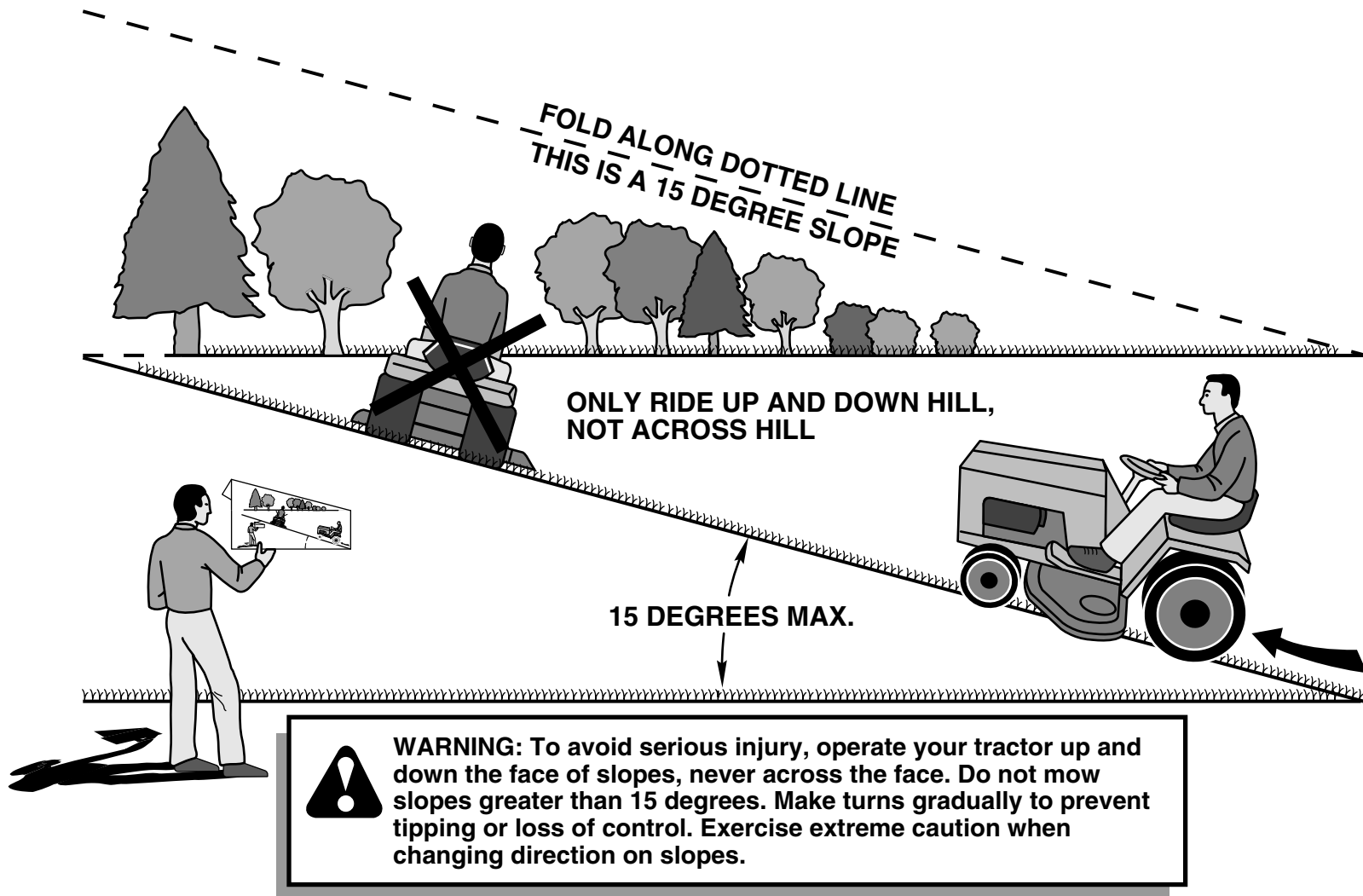

1. Fold this page along dotted line indicated above.
2. Hold page before you so that its left edge is vertically parallel to a tree trunk or other upright structure.
3. Sight across the fold in the direction of hill slope you want to measure.
4. Compare the angle of the fold with the slope of the hill.

# Get it fixed, at your home or ours!

Just Call:

**1-800-4-MY-HOME<sup>®</sup>**

(1-800-469-4663)

24 hours a day, 7 days a week

For the repair of major brand appliances **in your own home...**  
no matter who made it, no matter who sold it!

For your nearest **Sears Parts and Service** location,  
to bring in products like vacuums, lawn equipment and electronics.

For **Sears Parts & Service**, to order the replacement parts,  
accessories and owner's manuals that you need to do-it-yourself.

[www.sears.ca](http://www.sears.ca)

---

To purchase or inquire about a Sears Maintenance Agreement, call:

**1-800-361-6665**

9 a.m. – 11 p.m. Mon. – Fri., EST, 9 a.m. – 4 p.m. Sat.

---

Pour service en français:

**1-800-LE-FOYER<sup>MC</sup>**

(1-800-533-6937)

[www.sears.ca](http://www.sears.ca)



02488

® / ™ Trademarks of Sears, Roebuck and Co. used under license by Sears Canada

<sup>MD</sup> Marque déposée / <sup>MC</sup> Marque de commerce de Sears, Roebuck and Co. utilisée en vertu d'une licence de Sears Canada