

**SEARS**  
REPAIR  
PARTS  
MANUAL

**MODEL NO.  
944.604180**

**IMPORTANT:  
Read and follow  
all Safety Rules  
and Instructions  
Before Operating  
This Equipment**



**CRAFTSMAN®**

**18.5 HP\*  
ELECTRIC START  
42" MOWER  
AUTOMATIC TRANSMISSION  
LAWN TRACTOR**

\* The power rating as declared by the engine manufacturer is the average gross power output at the specified RPM of a typical production engine for the engine model measured using SAE Standards for engine gross power. Please refer to the engine manufacturer for details.

**Sears Canada, Inc., Toronto, Ontario M5B 2B8**

**586644032**

01.24.14 BD  
Printed in the U.S.A.

# HOW TO USE THIS MANUAL

This manual is designed to provide the customer with a means to identify the parts on his/her tractor when ordering repair parts. The illustrations may or may not represent the actual assemblies; therefore, it is not recommended to use this manual as a guide to assemble or disassemble the tractor. Some hardware and parts are drawn larger in order to more readily identify them.

Each tractor has its own model number.

The model number for your tractor can be found on the fender under the seat.

When ordering parts, always give the following information:

- Product - "Tractor"
- MODEL NUMBER - "944.604180"
- Part Number
- Part Description

## TABLE OF CONTENTS

SCHEMATIC .....	3
ELECTRICAL.....	4-5
CHASSIS .....	6-7
DRIVE.....	8-9
ENGINE.....	10-11
STEERING .....	12-13
MOWER DECK .....	14-15
MOWER LIFT.....	16
SEAT .....	17
DECALS.....	18
ENGINE BREAKDOWN.....	19-22
SEARS SERVICE .....	24

# TRACTOR - - MODEL NUMBER 944.604180

## SCHEMATIC

SCH11

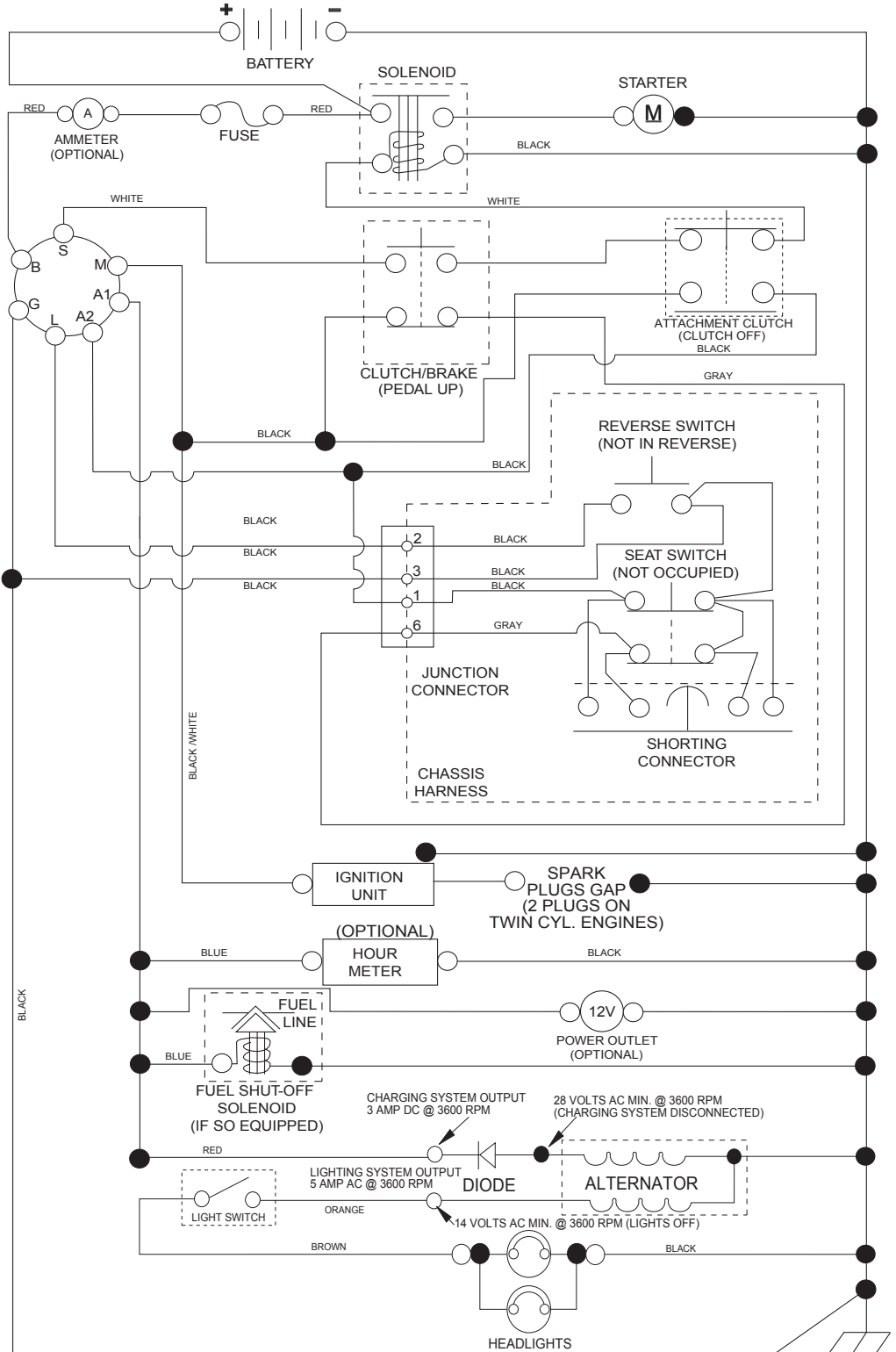

**NOTE**  
YOUR TRACTOR IS EQUIPPED WITH A SPECIAL ALTERNATOR SYSTEM. THE LIGHTS ARE NOT CONNECTED TO THE BATTERY, BUT HAVE THEIR OWN ELECTRICAL SOURCE. BECAUSE OF THIS, THE BRIGHTNESS OF THE LIGHTS WILL CHANGE WITH ENGINE SPEED. AT IDLE THE LIGHTS WILL DIM. AS THE ENGINE IS SPEEDED UP, THE LIGHTS WILL BECOME THEIR BRIGHTEST.

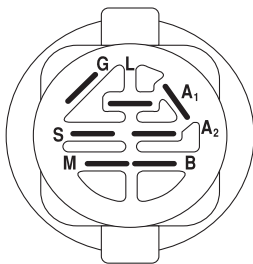

IGNITION SWITCH

POSITION	CIRCUIT "MAKE"
OFF	M+G+A1
RUN/OVERRIDE	B+A1
RUN	B+A1 L+A2
START	B + S + A1

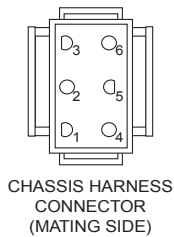

CHASSIS HARNESS CONNECTOR (MATING SIDE)

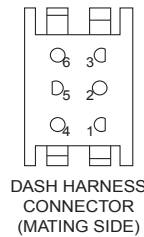

DASH HARNESS CONNECTOR (MATING SIDE)

WIRING INSULATED CLIPS  
NOTE: IF WIRING INSULATED CLIPS WERE REMOVED FOR SERVICING OF UNIT, THEY SHOULD BE RE-INSTALLED TO PROPERLY SECURE YOUR WIRING.

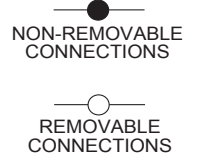

# TRACTOR - - MODEL NUMBER 944.604180

## ELECTRICAL

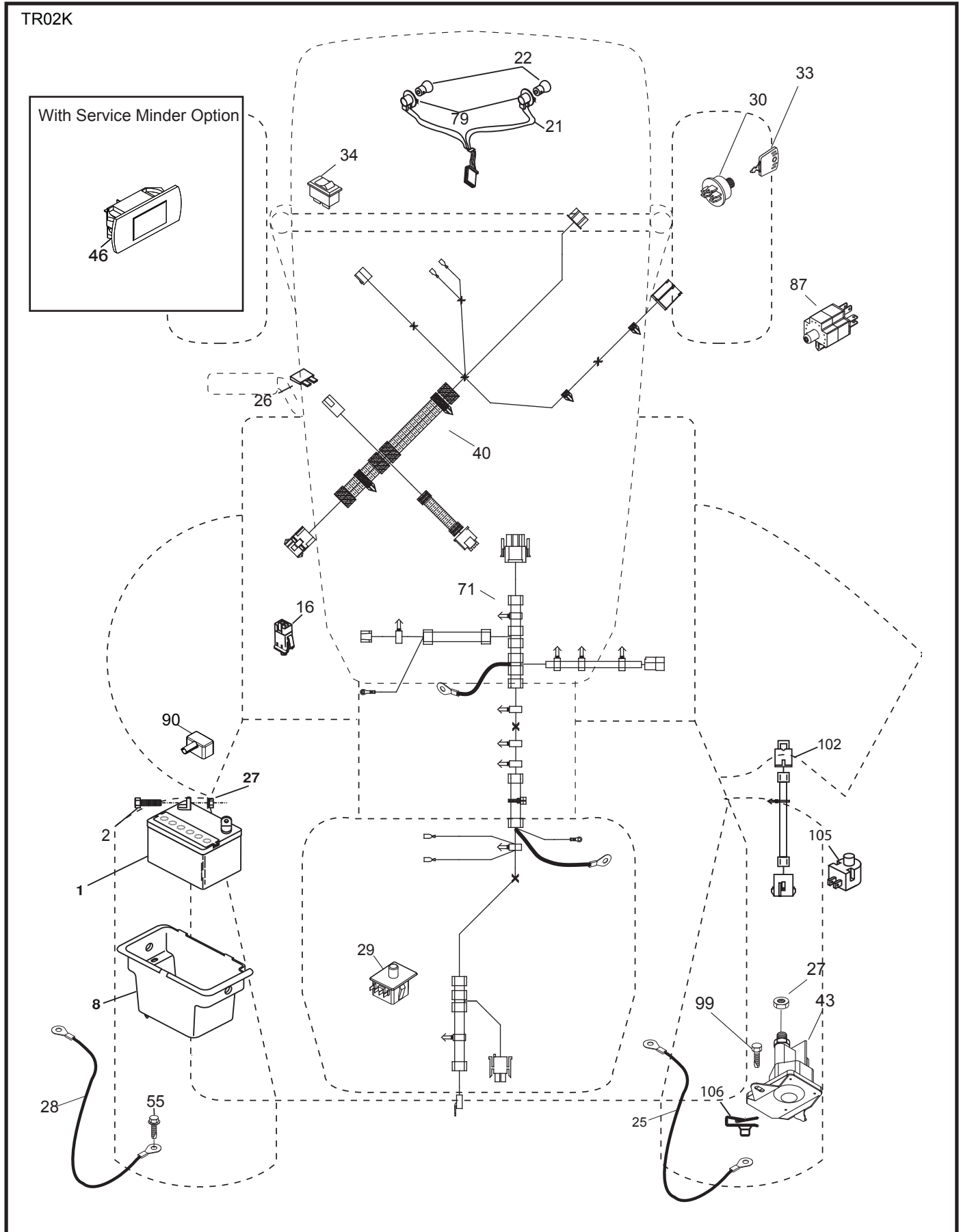

# TRACTOR - - MODEL NUMBER 944.604180

## ELECTRICAL

KEY NO.	PART NO.	DESCRIPTION
1	163465	Battery
2	74760412	Bolt Hex Hd 1/4-20 unc x 3/4
8	193228	Box Battery
16	176138	Switch Interlock Push-In
21	400252	Harness Socket Light w/4152J
22	4152J	Bulb Light
25	581498001	Cable Starter 6 Ga. 14.5"
26	175158	Fuse
27	73510400	Nut Keps Hex 1/4-20 unc
28	421686	Cable, Ground
29	192749	Switch, Seat
30	193350	Switch, Ign
33	411934	Key/Chain
34	110712X	Switch Light / Reset
40	581023101	Harness Ign. Dash <b>(if equipped with rear solenoid)</b>
--	401098	Harness Ign. Dash <b>(if equipped with front solenoid)</b>
43	192507	Solenoid
55	17060512	Screw Thdrol 5/16-18 x 3/4 TYTT
71	581023001	Harness Ign. Chassis <b>(if equipped with rear solenoid)</b>
--	400449	Harness Ign. Chassis <b>(if equipped with front solenoid)</b>
79	175242	Bulbholder Asm. Incandescent
87	197802	Switch Interlock Clutch Cable
90	435395	Cover Terminal Battery
99	17670412	Screw
102	581023401	Harness Pigtail
105	407568	Switch Reverse
106	174814	Pal Nut

**NOTE:** All component dimensions given in U.S. inches  
1 inch = 25.4 mm

# TRACTOR - - MODEL NUMBER 944.604180

## CHASSIS

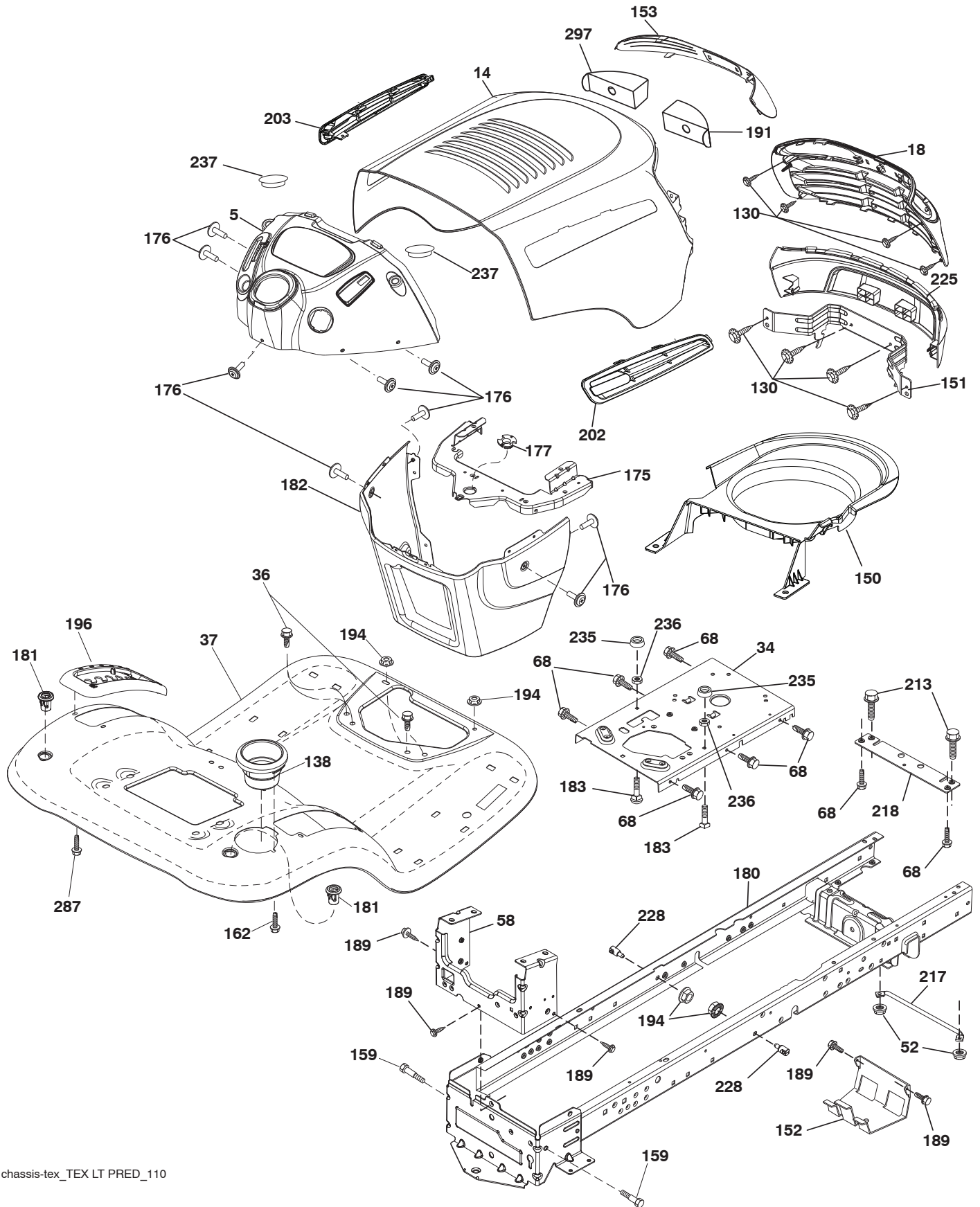

chassis-tex\_TEX LT PRED\_110

# TRACTOR - - MODEL NUMBER 944.604180

## CHASSIS

KEY NO.	PART NO.	DESCRIPTION
5	400801X428	Dash
14	198416X428	Hood
18	580427601	Grille
34	580910801	Plate Engine
36	17060512	Screw 5/16-18 x 3/4
37	414879X428	Fender
52	73680500	Nut Lock 5/16-18
58	412280	Drawbar Upper
68	17490508	Screw Thdrol 5/16-18 x 1/2
130	416358	Screw #10 x 0.750
138	193224X428	Cupholder
150	400267	Duct Heat Hood
151	187568	Bracket Pivot
152	199535	Shield Browning
153	400550X599	Lens Predator
159	17000612	Screw Hexwsh Thdrol 3/8-16 x 3/4
162	142432	Screw Hex Wsh Hi-Lo 1/4 x 1/2
175	199472	Crossmember
176	400776	Screw 10-24 x 5/8 Wshd Qdrx
177	195228	Bushing Steering
180	415063	Chassis
181	193102X428	Bushing
182	407176	Dash Lower
183	74520520	Bolt 5/16-18 x 1-1/4
189	17000512	Screw 5/16-18 x 3/4
191	416502	Insert RH
194	73900500	Nut Lock Hex Flange 5/16-18
196	414579	Console Asm. Deck Lift
202	580427401	Vent Hood RH
203	580427501	Vent Hood LH
213	74760512	Bolt 5/16-18 x 3/4
217	409167	Rod Pivot Hood
218	196395	X-Piece Hood Step
225	400549X615	Bumper Hood
228	195161	Stud Fastener
235	406129	Spacer Fender
236	73930500	Nut Center Lock 5/16-18
237	403704	Plug Mount
287	17600406	Screw 1/4-20 x 3/8
297	401827	Insert LH

**NOTE:** All component dimensions given in U.S. inches  
1 inch = 25.4 mm

# TRACTOR - - MODEL NUMBER 944.604180

## DRIVE

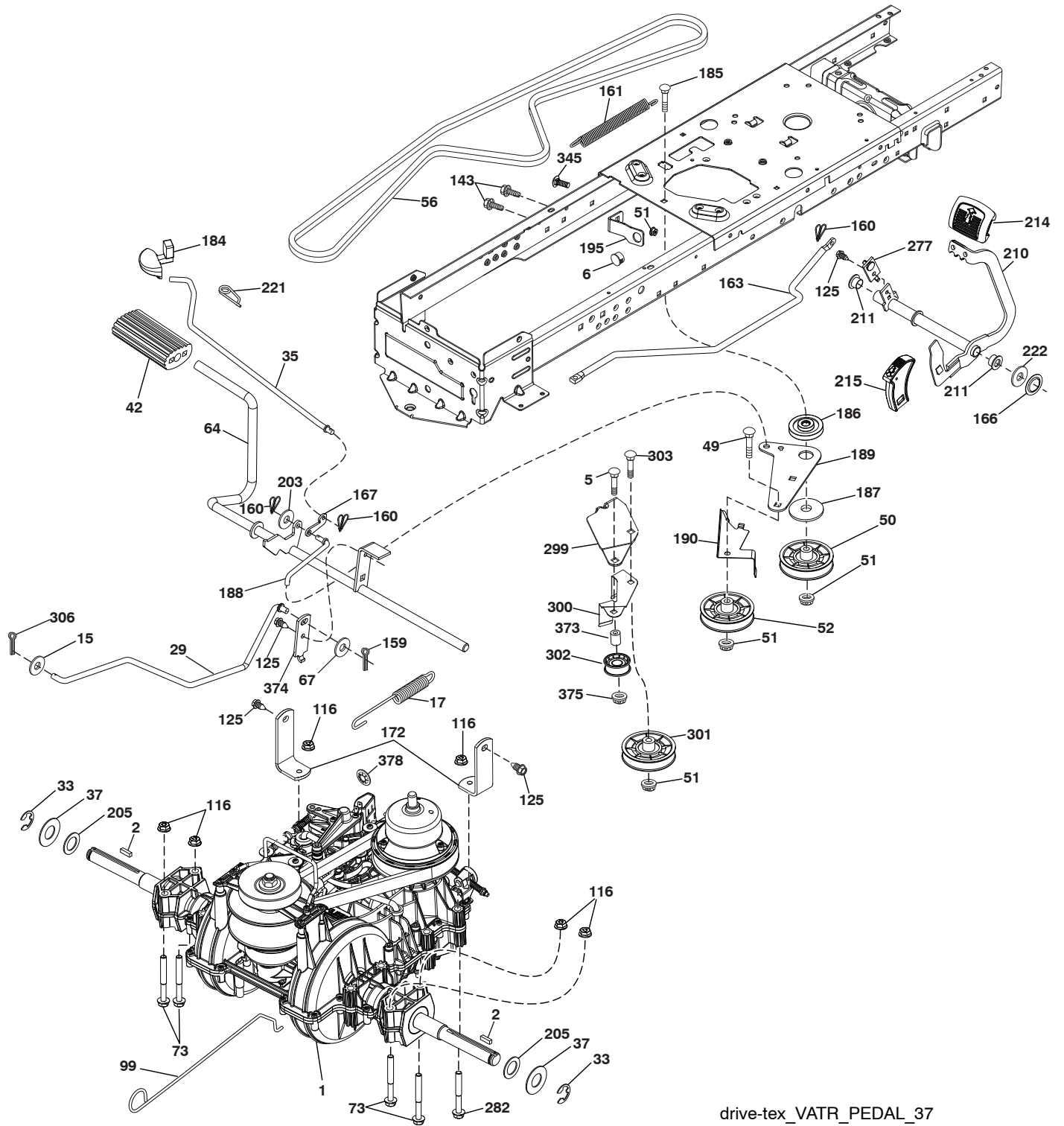

drive-tex\_VATR\_PEDAL\_37



# TRACTOR - - MODEL NUMBER 944.604180

## DRIVE

KEY NO.	PART NO.	DESCRIPTION	KEY NO.	PART NO.	DESCRIPTION
1	-----	Transaxle, Variator SD Pedal (580486201) (Order parts from transaxle manufacturer.)	187	19133210	Washer 13/32 x 2 x 10 Ga.
2	123583X	Key Square	188	194323	Link Clutch Ground Drive
5	74760636	Bolt 3/8-16 x 2-1/4	189	194317	Bellcrank Ground Drive
6	124028X	Bushing Snap	190	194318	Keeper. Bellcrank
15	19131316	Washer 13/32 x 13/16 x 16 Ga.	195	581504601	Bracket Brake
17	584954001	Spring, Brake	203	19111116	Washer 11/32 x 11/16 x 16 Ga.
29	584823101	Brake VATR	205	121748	Washer 25/32 x 1-5/8 16 Ga.
33	12000001	Ring E	210	448270	Rocker Asm. Pedal
35	401031	Rod, Brake, Park	211	120183X	Bearing Nylon
37	188967	Washer .793 x 1.637 x 060	214	421263	Pedal Forward
42	8883R	Cover, Foot Pedal	215	448254	Pad Pedal Reverse
49	72110614	Bolt 3/8-16 unc	221	403187	Retainer Spring
50	194327	Idler Flat	222	79212010	Washer Flat
51	73900600	Nut Lock	277	448500	Link Rocker Pedal
52	194326	Idler V-Groove	282	74490548	Screw Thdrol 5/16-18 x 3
56	197253	V-Belt, Drive	299	415683	Bracket Mount
64	448353	Subasm. Shaft Pedal Brake	300	415681	Keeper Idler
67	19131312	Washer 13/32 x 13/16 x 12 Ga.	301	415680	Pulley Idler Groove
73	74490544	Bolt Hex 5/16-18 x 3.75	302	581420501	Puller Idler Flat
99	435935	Rod Bypass	303	72110618	Bolt
116	73900500	Nut Lock Hex Flange 5/16-18	306	76020416	Cotter Pin
125	17000512	Screw 5/16-18 x 3/4	345	72110606	Bolt 3/8-16 unc
143	17490508	Screw Thdrol 5/16-18 x 1/2 TYTT	373	581461801	Spacer Idler
159	76020412	Pin Cotter 1/8 x 3/4	374	581475201	Arm Control Brake
160	169484	Retainer Clip	375	73680600	Nut Crownlock 3/8-16 unc
161	105709X	Spring Return Clutch	378	584287701	Push Nut 8 mm
163	583971301	Rod Control			
166	429164	Nut Push .625			
167	405257	Latch Brake Parking			
172	583974201	Strap Torque			
184	199996X667	Handle Park Brk.			
185	72110622	Bolt 3/8-16 unc x 2-3/4			
186	194321	Spacer Retainer			

**NOTE:** All component dimensions given in U.S. inches  
1 inch = 25.4 mm

# TRACTOR - - MODEL NUMBER 944.604180

## ENGINE

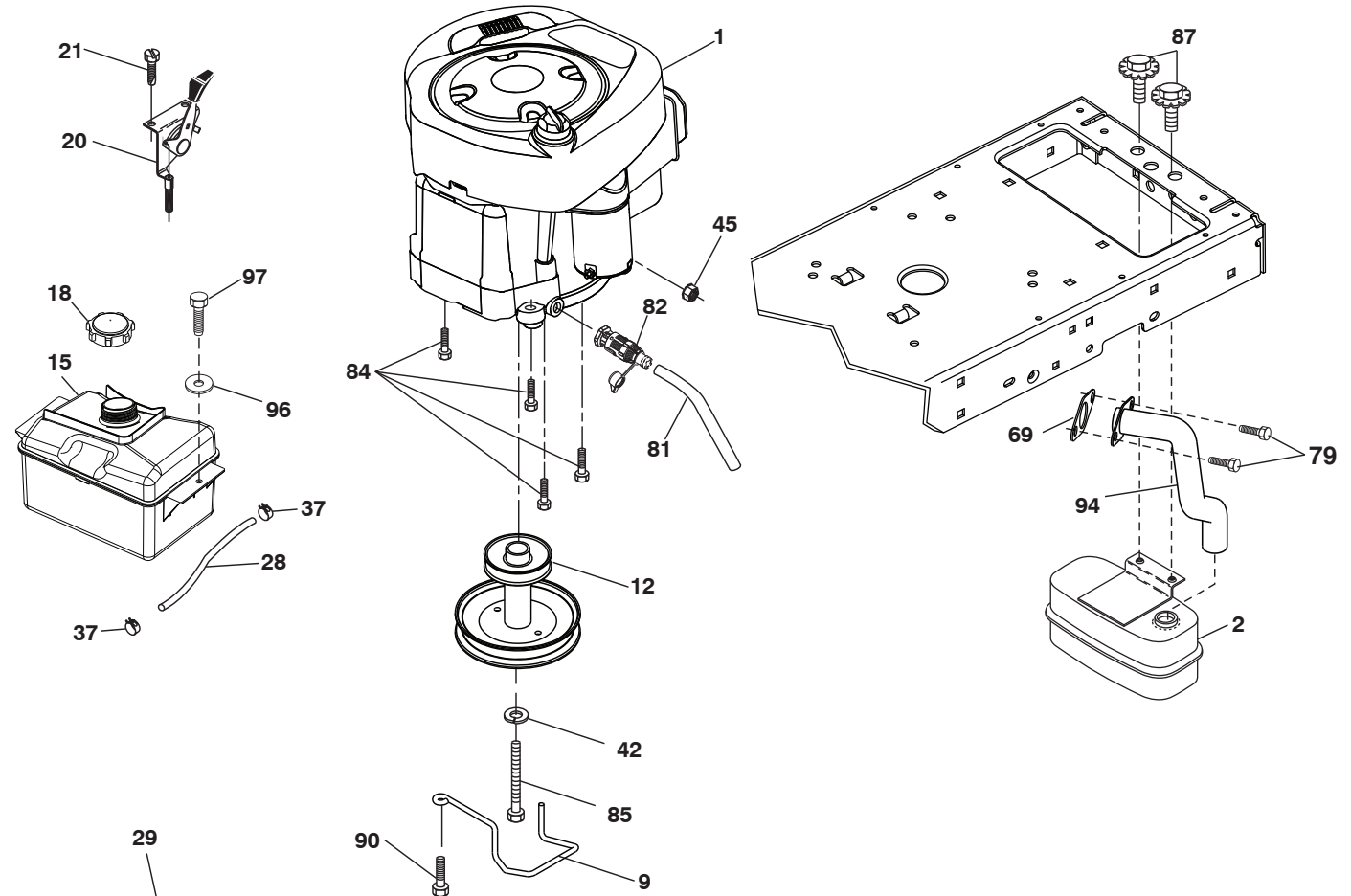

**OPTIONAL EQUIPMENT**  
**SPARK ARRESTER**

engine-tex\_BS\_77

# TRACTOR - - MODEL NUMBER 944.604180

## ENGINE

KEY PART NO.	PART NO.	DESCRIPTION
1	---	Engine B&S Model No. 33R777-0005-G1 (586306801) (See engine breakdown.)
2	580532301	Muffler
9	194319	Keeper Belt Engine
12	401985	Pulley Engine
15	581289901	Tank Fuel
18	430220	Cap Asm Fuel
20	170545	Control Throttle/Choke
21	416358	Screw 10 x .750 BOS Thread
28	137040	Fuel Line
29	137180	Spark Arrester Kit
37	123487X	Clamp Hose
42	10040700	Washer Lock 7/16
45	73510400	Nut Keps Hex 1/4-20 unc
69	165291	Gasket
79	192334	Screw 5/16-18 x .75
81	148456	Extension Drain Oil
82	428287	Valve Oil Drain
84	17060620	Screw 3/8-16 x 1-1/4
85	173937	Bolt Hex 7/16-20 x 4 x Gr. 5-1.5
87	171877	Bolt 5/16-18 x 3/4 w/Sems
90	17000616	Screw 3/8-16 x 1.0
94	581880901	Exhaust Tube
96	19091416	Washer 9/32 x 7/8 x 16 Ga.
97	17670412	Screw 1/4-20 x 3/4

**NOTE:** All component dimensions given in U.S. inches  
1 inch = 25.4 mm

### Engine Power Rating Information

The gross power rating for individual gas engine models is labeled in accordance with SAE (Society of Automotive Engineers) code J1940 (Small Engine Power & Torque Rating Procedure), and rating performance has been obtained and corrected in accordance with SAE J1995 (Revision 2002-05). Torque values are derived at 3060 RPM; horsepower values are derived at 3600 RPM. Actual gross engine power will be lower and is affected by, among other things, ambient operating conditions and engine-to-engine variability. Given both the wide array of products on which engines are placed and the variety of environmental issues applicable to operating the equipment, the gas engine will not develop the rated gross power when used in a given piece of power equipment (actual "on-site" or net power). This difference is due to a variety of factors including, but not limited to, accessories (air cleaner, exhaust, charging, cooling, carburetor, fuel pump, etc.), application limitations, ambient operating conditions (temperature, humidity, altitude), and engine-to-engine variability. Due to manufacturing and capacity limitations, Briggs & Stratton may substitute an engine of higher rated power for this Series engine.

# TRACTOR - - MODEL NUMBER 944.604180

## STEERING ASSEMBLY

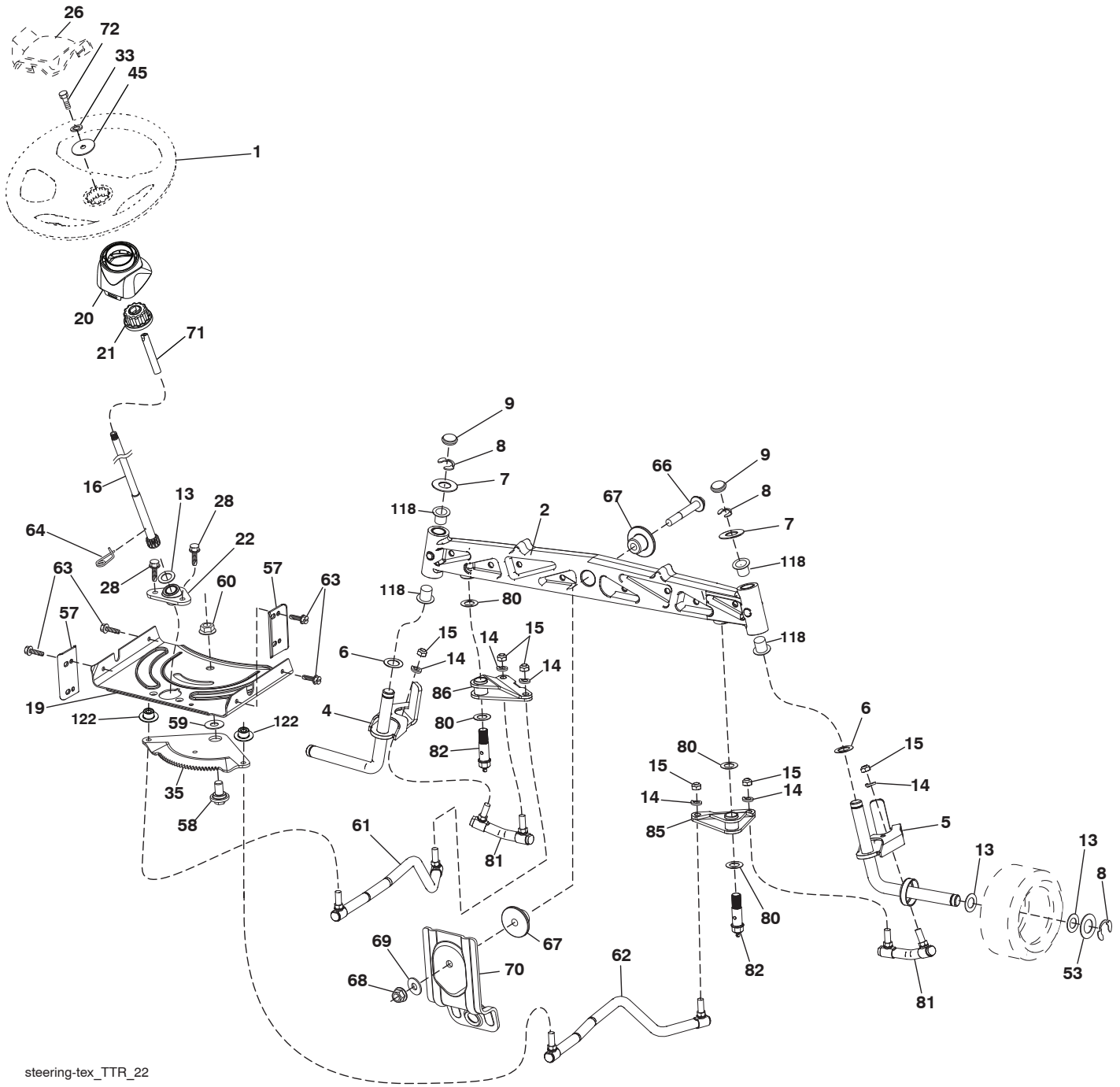

steering-tex\_TTR\_22

# TRACTOR - - MODEL NUMBER 944.604180

## STEERING ASSEMBLY

KEY NO.	PART NO.	DESCRIPTION
1	414803X428	Wheel, Steering
2	436870	Axle Asm., Front
4	436873	Spindle Asm., LH
5	436874	Spindle Asm., RH
6	6266H	Washer Thrust 0.75 x 1.23
7	121748X	Washer 25/32 x 1-5/8 x 16 Ga.
8	12000029	Ring, Clip #T5304-75
9	184946X667	Cap, Spindle
13	121749X	Washer 25/32 x 1-1/4 x 16 Ga.
14	10040600	Washer Lock 3/8
15	73540600	Nut, Crown Lock 3/8-24 unf
16	441456	Shaft Steering
19	194729	Plate Steering
20	400803X428	Boot, Steering
21	437747	Adapter, Wheel Steering
22	194845	Bushing Strg. Blk
26	414852X428	Insert, Wheel Steering
28	17000612	Screw 3/8-16 x 3/4
33	10040500	Washer Lock 5/16
35	440770	Gear, Sector Plate
45	19113812	Washer
53	188967	Washer Hardened .793 x 1.637 x .060
57	407465	Bracket Upstop
58	194747	Bolt Shoulder Sector Pivot CFM
59	194748	Washer Thrust Sector Steering
60	73971000	Nut Flange Lock 5/8-11
61	436884	Draglink, LH
62	436885	Draglink, RH
63	17000512	Screw 5/16-18 x 3/4
64	199849	Retainer Clip Spring Steering
66	71020748	Bolt Hex Fghd 7/16-14 x 3 Serr
67	194737	Bushing PM Front Axle
68	73900700	Nut Lock Flange 7/16-14 Gr. 5
69	199162	Washer 1.5 x .505 x .118
70	196197	Bracket Deck Susp. Front
71	190752	Shaft Extension Steering
72	428982	Bolt 5/16-18 x 4
80	1370H	Washer
81	436887	Link Cross RH
82	442147	Pivot Bolt
85	441873	Pivot RH
86	441872	Pivot LH
118	406013	Bushing Axle Cast
122	444962	Cap Gear Sector

**NOTE:** All component dimensions given in U.S. inches  
1 inch = 25.4 mm

TRACTOR - - MODEL NUMBER 944.604180

MOWER DECK

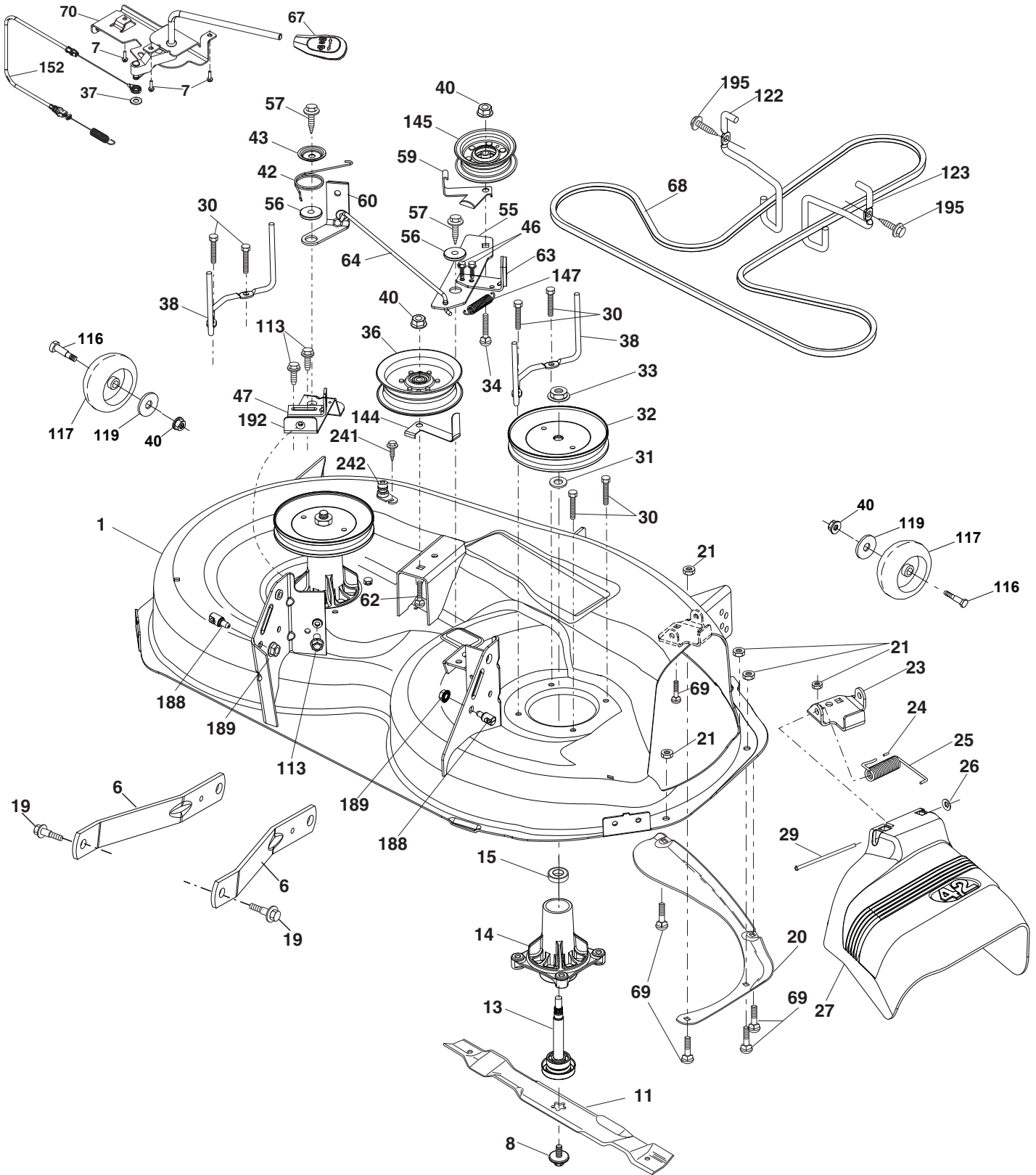

# TRACTOR - - MODEL NUMBER 944.604180

## MOWER DECK

KEY NO.	PART NO.	DESCRIPTION	KEY NO.	PART NO.	DESCRIPTION
1	196495	Deck Weldment Mower	59	141043	Guard, Tuv Idler
6	195186	Arm Suspension	60	197261	Arm Brake Mower
7	416358	Screw #10 x .750 BOS Thread	62	72110616	Bolt Rd Hd Sq Nk 3/8-16 unc x 2
8	193003	Bolt/Washer asm 7/16-20 unf	63	199477	Arm Brake Mower
11	424752	Blade, 42" 3NI	64	199790	Link Brake Asm
--	422719	Blade, 42"SP 3NI	67	198398X428	Handle Clutch Cable
--	134149	Blade, Mulching	68	429636	V-Belt
--	139775	Blade, 42" Mulching Premium	69	72140505	Bolt 5/16-18 x 5/8
--	138971	Blade, 42" Hi-Lift (For bagging or discharge)	70	401246	Clutch Asm Manual
13	192872	Shaft Assembly, Mandrel	113	17000510	Bolt 5/16-18 Hex
14	187281	Housing, Mandrel	116	4898H	Bolt Shoulder
15	110485X	Bearing, Ball, Mandrel	117	188606	Wheel Gage
19	196539	Bolt, Shoulder	119	19121414	Washer
20	159770	Baffle, Vortex	122	197258	Keeper Belt Engine LH
21	73680500	Nut, Crownlock 5/16-18 unc	123	197259	Keeper Belt Engine RH
23	192557	Bracket, Deflector	144	199204	Keeper Belt
24	105304X	Cap, Sleeve	145	193197	Pulley Idler, Flat
25	197026	Spring, Torsion, Deflector	147	401971	Spring Return
26	110452X	Nut, Push	152	584243501	Manual Clutch Cable
27	424469	Shield, Deflector	188	195161	Stud Fastener
29	131491	Rod, Hinge	189	73900500	Nut Lock Hex Flange
30	173984	Screw Thdrol Rolling Wsh Hd	192	197260	Bracket Brake Stand LH
31	187690	Washer, Spacer	195	17000612	Screw Hex Wsh Thdr 3/8-16 x 3/4
32	197473	Pulley, Mandrel	241	152927	Screw TT #10-32.5. 3/8 Flange
33	400234	Nut, Toplock, Flanged	242	415598	Port Washout
34	72110612	Bolt Carr Sh. 3/8-16 x 1-1/2 Gr. 5	--	416405	Coupling Quick Connect
36	197379	Pulley, Idler	--	192870	Mandrel Assembly (Includes housing (key #14), shaft assembly (key #13), and bearing (key #15) and nut (key #33) only - pulley/washer and blade bolt/washers not included)
37	19131316	Washer	--	425415	Replacement Mower, Complete
38	432520	Keeper Belt Mandrel			
40	73900600	Nut, Lock Flg. 3/8-16 unc			
42	198410	Spring Torsion Brake			
43	197256	Spring Torsion Retainer			
46	137729	Screw Thd Roll 1/4-20 x 5/8			
47	197250	Bracket Clutch Cable			
55	437110	Arm, Idler			
56	199092	Spacer, Retainer			
57	17000616	Screw 3/8-16 x 1			

**NOTE:** All component dimensions given in U.S. inches  
1 inch = 25.4 mm

# TRACTOR - - MODEL NUMBER 944.604180

## MOWER LIFT

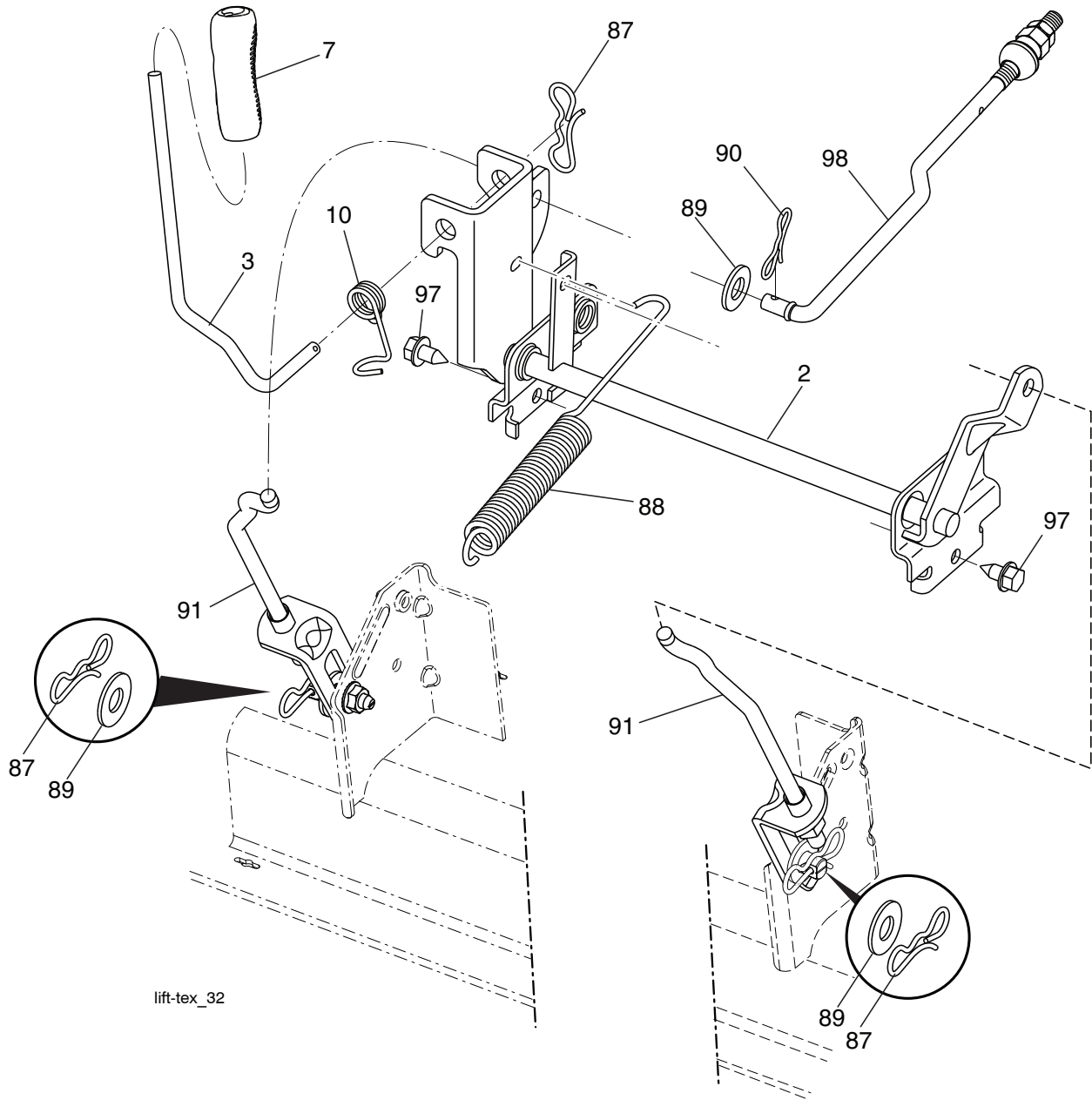

lift-tex\_32

KEY NO.	PART NO.	DESCRIPTION
2	422027	Shaft Asm., Lift
3	195231	Lever Asm., Lift RH
7	445060X428	Grip, Lever
10	196314	Spring Torsion
87	194209	Pin Cotter 7/16 Bow Tie Lock
88	410710	Spring Lift Assist
89	19191912	Washer Clear Zinc

KEY NO.	PART NO.	DESCRIPTION
90	194208	Pin Cotter 5/16 Bow Tie Lock
91	197984	Link Lift Asm Rear
97	17000612	Screw 3/8-16 x .75
98	420525	Link Lift Susp. Front Mower

**NOTE:** All component dimensions given in U.S. inches  
1 inch = 25.4 mm



# TRACTOR - - MODEL NUMBER 944.604180

## SEAT ASSEMBLY

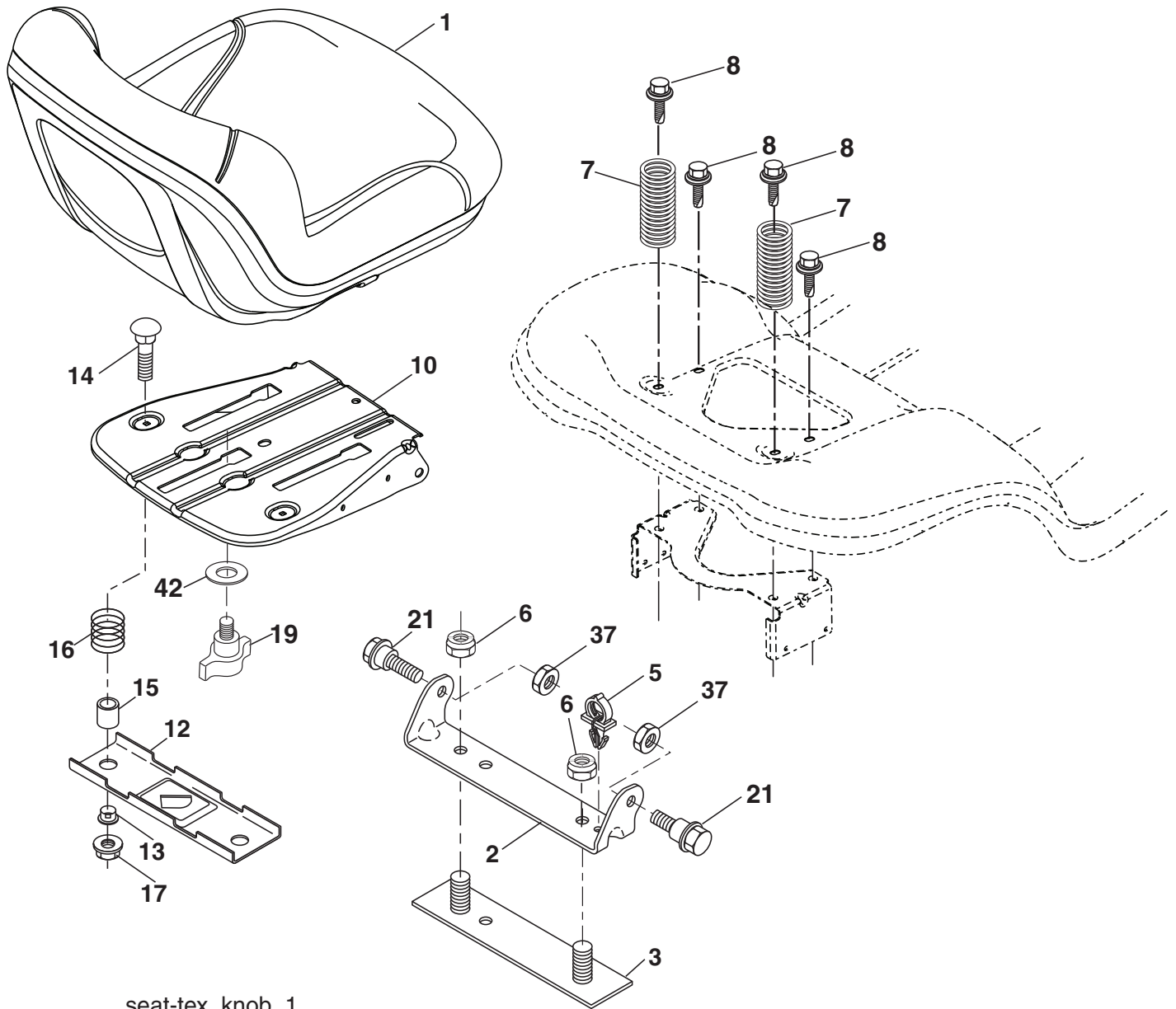

seat-tex\_knob\_1

KEY NO.	PART NO.	DESCRIPTION
1	423644	Seat
2	180166	Bracket Pivot Fender
3	140675	Strap, Asm Fender
5	145006	Clip
6	73800600	Nut, Lock W/Ins. 3/8-16 unc
7	124181X	Spring, Seat Cprsn
8	171877	Bolt 5/16-18 unc x 3/4 w/Sems
10	441805	Pan, Seat
12	199370	Bracket Mnt
13	121248X	Bushing
14	72050412	Bolt 1/4-20 x 1-1/2

KEY NO.	PART NO.	DESCRIPTION
15	134300	Spacer
16	123740X	Spring
17	123976X	Nut 1/4
19	199372	Knob Seat
21	171852	Bolt, Shoulder 5/16-18
37	73800500	Nut, Lock 5/16-18 unc
42	199371	Washer Cup Seat

**NOTE:** All component dimensions given in U.S. inches  
1 inch = 25.4 mm

# TRACTOR - - MODEL NUMBER 944.604180

## DECALS

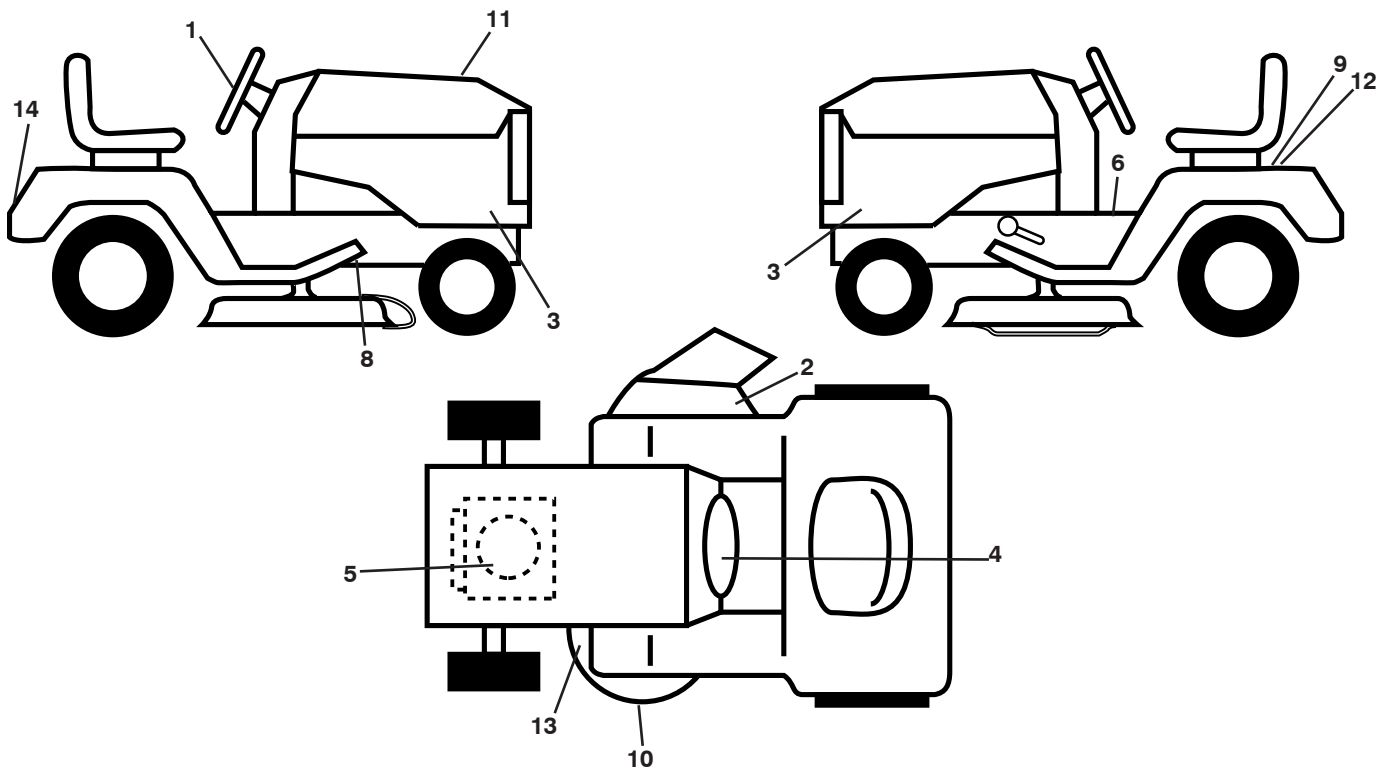

### KEY PART NO. NO.

KEY PART NO.	PART NO.	DESCRIPTION
1	439525	Decal, Steering
2	581579501	Decal, Mower Warn.
3	586642501	Decal, PNL SD RH/LH
4	581579901	Decal, Warning Spark
5	586620801	Decal, Engine HP
6	581579001	Decal, Fender Operator's
8	421534	Decal, V-Belt Schematic Drive
9	149517	Decal, Battery Dnge/Poi
10	426593	Decal, Tractor Precision Cut
11	586620901	Decal, Replacement

### KEY PART NO. NO.

KEY PART NO.	PART NO.	DESCRIPTION
12	448709	Decal, Batt. Diehard
13	581580001	Decal, Mower V-Belt SCH.
14	441122	Decal, Fender
--	581724801	Decal, Bypass
--	193226X428	Pad, Footrest LH
--	400981X428	Pad, Foot Pedal
--	586644024	Manual, Operator's (English/French)
--	586644032	Manual, Parts (English/French)

## WHEELS AND TIRES

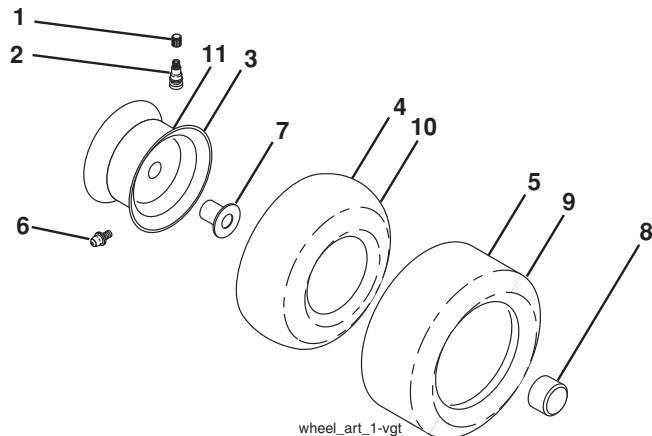

### KEY PART NO. NO.

KEY PART NO.	PART NO.	DESCRIPTION
1	59192	Cap, Valve, Tire
2	65139	Stem, Valve
3	106732X613	Rim Assembly, Front
4	59904	Tube, Front
5	106222X	Tire, Front 15 x 6-6
6	278H	Fitting, Grease
7	9040H	Bearing, Flange
8	104757X613	Cap, Axle (Front Wheel Only)
9	138468	Tire, Rear 20 x 8-8
10	7152J	Tube, Rear
11	106108X613	Rim Assembly, Rear
--	144334	Sealant, Tire (10 oz. Tube)

**NOTE:** All component dimensions given in U.S. inches  
1 inch = 25.4 mm

# TRACTOR - - MODEL NUMBER 944.604180

## BRIGGS ENGINE - MODEL NUMBER 33R777, TYPE NUMBER 0005-G1

48 SHORT BLOCK

1036 EMISSIONS LABEL

1058 OPERATOR'S MANUAL

1329 REPLACEMENT ENGINE

1330 REPAIR MANUAL

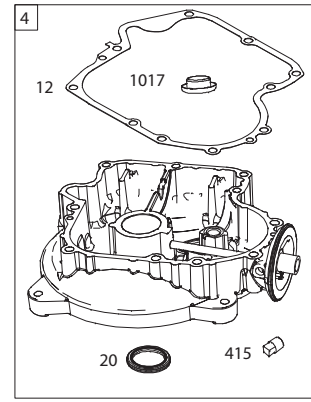
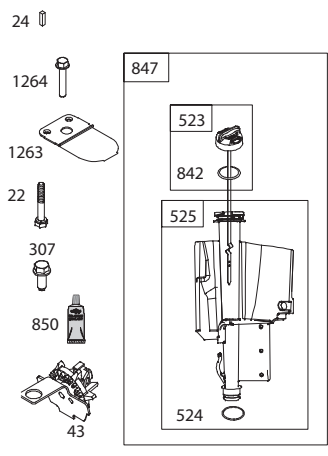
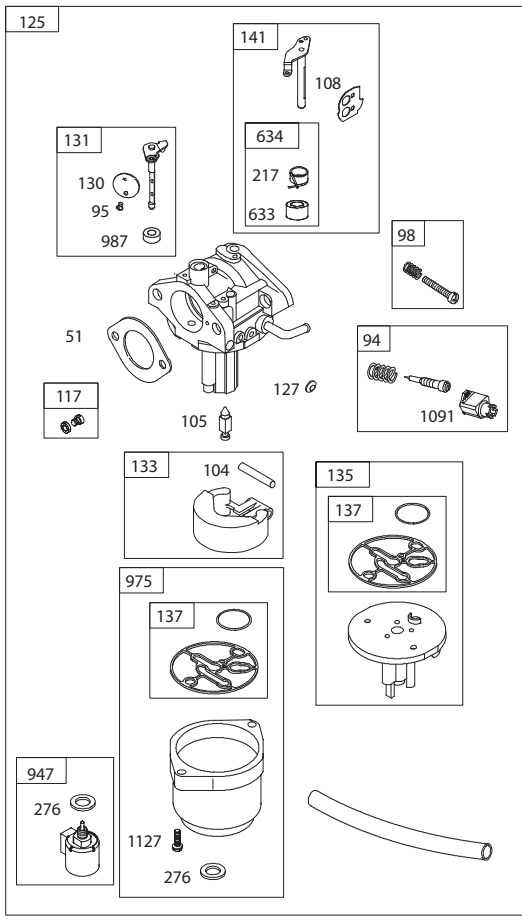
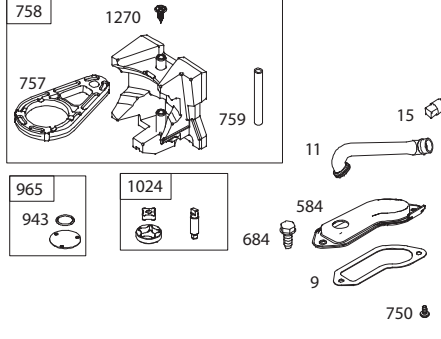
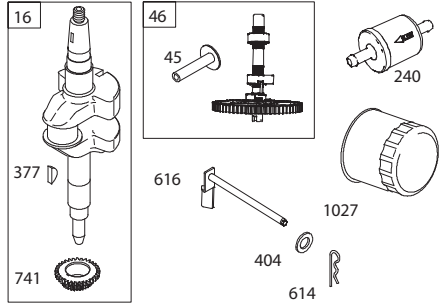
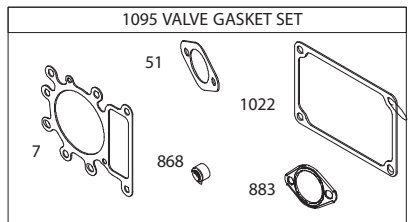
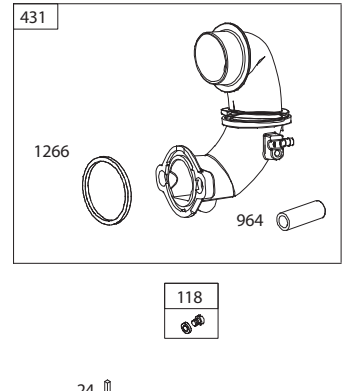
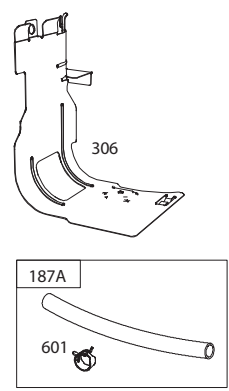
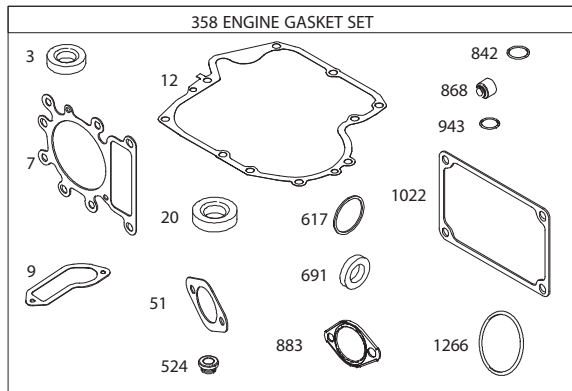
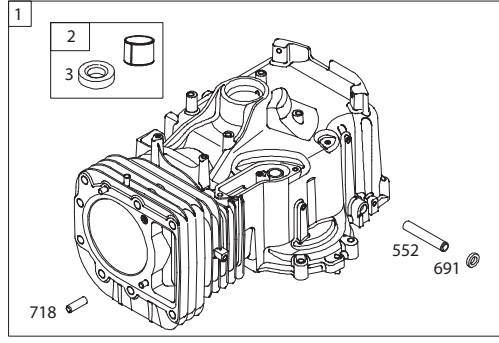
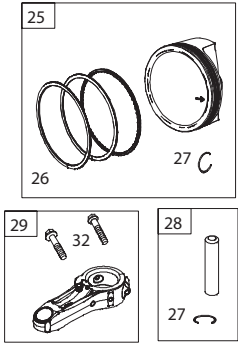
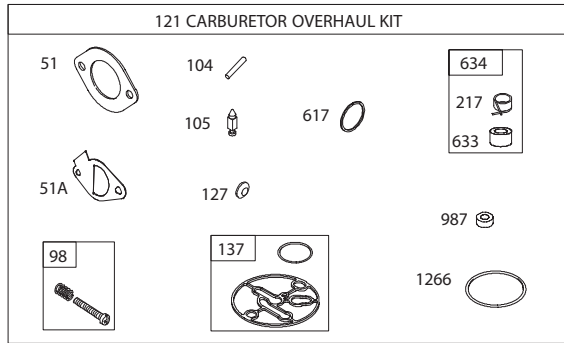

# TRACTOR - - MODEL NUMBER 944.604180

## BRIGGS ENGINE - MODEL NUMBER 33R777, TYPE NUMBER 0005-G1

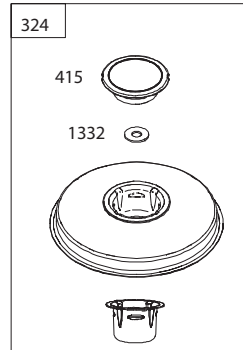
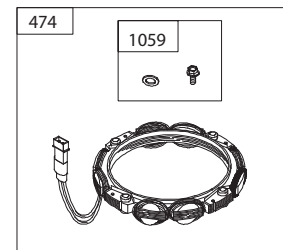
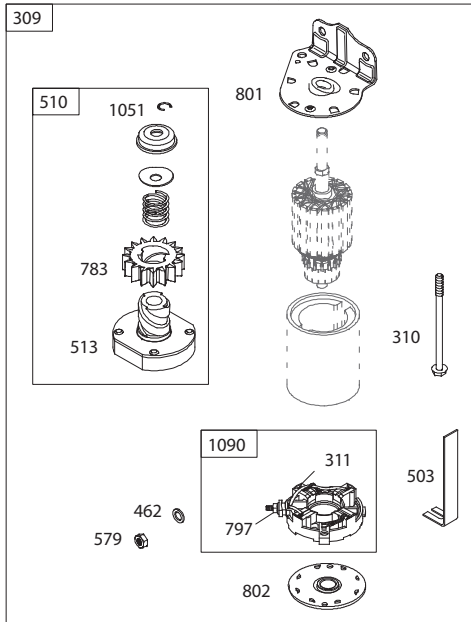
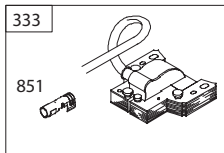
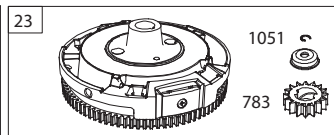
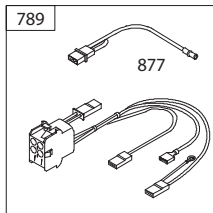
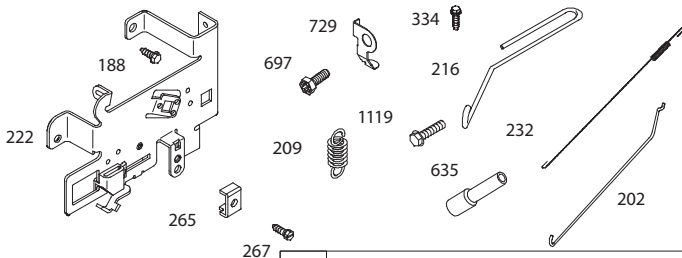
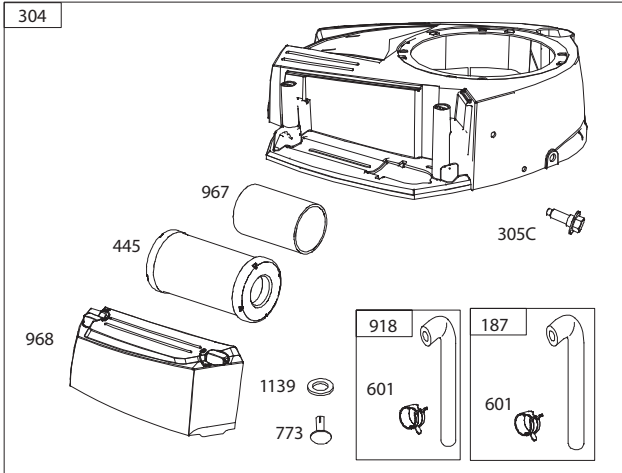
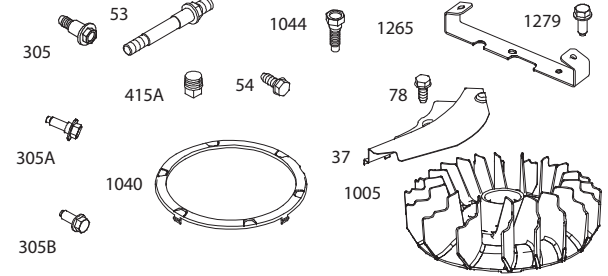
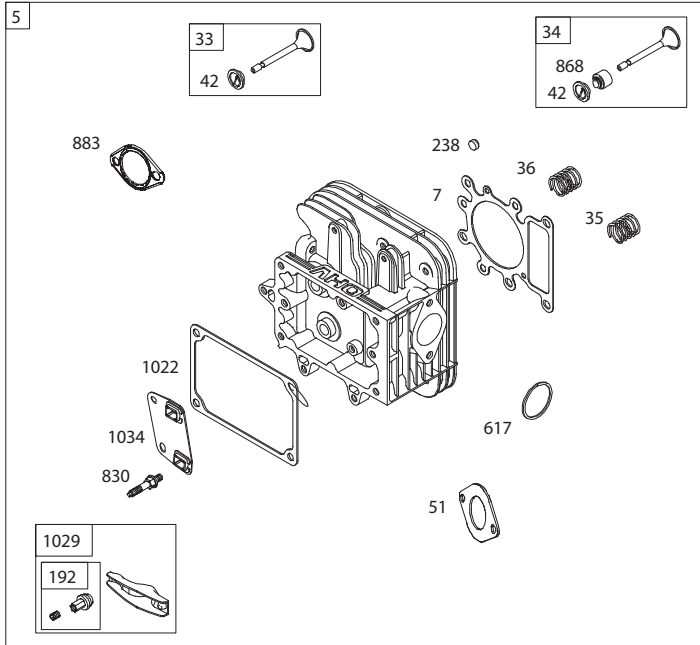
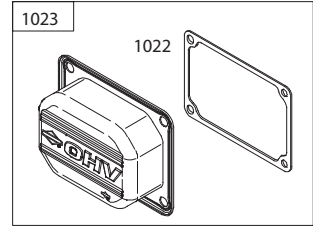
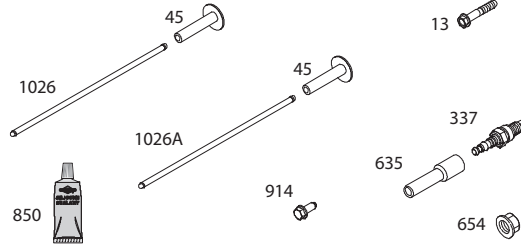
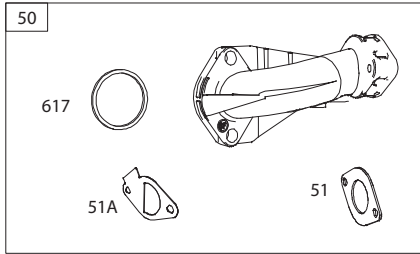

**TRACTOR - - MODEL NUMBER 944.604180**  
**BRIGGS ENGINE - MODEL NUMBER 33R777, TYPE NUMBER 0005-G1**

<b>KEY NO.</b>	<b>PART NO.</b>	<b>DESCRIPTION</b>	<b>KEY NO.</b>	<b>PART NO.</b>	<b>DESCRIPTION</b>
1	591465	Cylinder Assembly	187	791805	Line-Fuel (Formed)
2	797673	Kit-Bushing/Seal	187A	791766	Line-Fuel (Cut to Required Length)
3	391086s	Seal-Oil (Magneto Side)	188	691693	Screw (Control Bracket)
4	592849	Sump-Engine	192	691986	Adjuster-Rocker Arm
5	591750	Head-Cylinder	202	691841	Link-Mechanical Governor
7	794114	Gasket-Cylinder Head	209	796260	Spring-Governor (Green)
9	697109	Gasket-Breather	216	691840	Link-Choke
11	794683	Tube-Breather	217	695409	Spring-Choke Return
12	697110	Gasket-Crankcase	222	694042	Bracket-Control
13	592244	Screw (Cylinder Head)	227	691374	Lever-Governor Control
15	690946	Plug-Oil Drain	232	691842	Spring-Governor Link
16	591762	Crankshaft	238	691843	Cap-Valve
20	795387	Seal-Oil (PTO Side)	240	394358s	Filter-Fuel
22	692125	Screw (Crankcase Cover/Sump)	265	691024	Clamp-Casing
23	591759	Flywheel	267	794904	Screw (Casing Clamp)
24	591757	Key-Flywheel (Steel)	276	695410	Washer-Sealing
25	795858	Piston Assembly (Standard)	304	592814	Housing-Blower
	795877	Piston Assembly (020" Oversize)	305	697102	Screw (Blower Housing)
26	794126	Ring Set (Standard)			(1/4-20x1.21)
	794127	Ring Set (.020" Oversize)	305A	793376	Screw (Blower Housing)
27	698469	Lock-Piston Pin			(1/4-20x.68)
28	795861	Pin-Piston	305B	795891	Screw (Blower Housing)
29	794122	Rod-Connecting			(#10-16x.43)
32	791118	Screw (Connecting Rod)	305C	799370	Screw (Blower Housing)
33	591752	Valve-Exhaust			(1/4-20x.90)
34	591751	Valve-Intake	306	794953	Shield-Cylinder
35	691279	Spring-Valve (Intake)	307	691693	Screw (Cylinder Shield)
36	691279	Spring-Valve (Exhaust)	309	693551	Motor-Starter
37	699882	Guard-Flywheel	310	690323	Screw (Starter Motor)
42	499586	Keeper-Valve	311	497608	Brush Set
43	691968	Slinger-Governor/Oil	324	796309	Screen/Cup Assembly
45	690564	Tappet-Valve	333	799650	Armature-Magneto
46	793880	Camshaft	334	691061	Screw (Magneto Armature)
48	N/A	Short Block (Not Available At This Printing)	337	792015	Plug-Spark
50	592842	Manifold-Intake	358	796187	Gasket Set-Engine
51	692137	Gasket-Intake	377	691639	Key-Woodruff
51A	796081	Gasket-Intake	404	691691	Washer (Governor Crank)
53	591260	Stud (Carburetor)	415	794129	Plug (Cover/Retainer)
54	691148	Screw (Intake Manifold)	415A	794903	Plug (Intake Manifold)
78	691693	Screw (Flywheel Guard)	431	799043	Elbow-Intake
94	793610	Kit-Idle Mixture	445	793569	Filter-Air Cleaner Cartridge
95	690718	Screw (Throttle Valve)	462	691261	Washer (Starter Cable)
98	695408	Kit-Idle Speed	474	592831	Alternator
104	694918	Pin-Float Hinge	503	691532	Strap-Starter
105	696136	Valve-Float Needle	505	691251	Nut (Governor Control Lever)
108	695419	Valve-Choke	510	693699	Drive-Starter
117	796251	Jet-Main (Standard)	513	692024	Clutch-Drive
118	791406	Jet-Main (High Altitude) (5000/9000 Feet)	523	699908	Dipstick
121	796184	Kit-Carburetor Overhaul	524	691032	Seal-Dipstick Tube
125	591736	Carburetor	525	697184	Tube-Dipstick
127	690727	Plug-Welch	552	697144	Bushing-Governor Crank
130	792747	Valve-Throttle	562	691119	Screw (Governor Control Lever)
131	792765	Kit-Throttle Shaft	579	691029	Nut (Starter Cable)
133	694914	Float-Carburetor	584	794682	Cover-Breather Passage
135	698780	Tube-Fuel Transfer	601	791850	Hose-Clamp (Green)
137	698781	Gasket-Float Bowl	614	691620	Pin-Cotter (Governor Crank)
141	592937	Kit-Choke Shaft	616	692012	Crank-Governor
			617	692138	Seal-O Ring (Intake Manifold) (Red)

**TRACTOR - - MODEL NUMBER 944.604180**  
**BRIGGS ENGINE - MODEL NUMBER 33R777, TYPE NUMBER 0005-G1**

<b>KEY NO.</b>	<b>PART NO.</b>	<b>DESCRIPTION</b>	<b>KEY NO.</b>	<b>PART NO.</b>	<b>DESCRIPTION</b>
633	699813	Seal-Choke/Throttle (Choke Shaft)	1127	695407	Screw (Float Bowl)
634	698779	Spring/Seal Assembly	1139	796449	Washer (Fuel Pump)
635	691909	Boot-Spark Plug	1263	697124	Reed-Breather
654	690958	Nut (Carburetor) (Serrated)	1264	697104	Screw (Breather Reed)
684	697157	Screw (Breather Passage Cover)	1265	794151	Support-Blower Housing
691	692407	Seal-Governor Shaft	1266	691917	Seal-O Ring (Intake Elbow) (Red)
697	791680	Screw (Drive Cap)	1270	793243	Plug-AVS Counterweight
718	690959	Pin-Locating	1279	691108	Screw (Blower Housing Support)
729	691224	Clip-Wire	1329	N/A	Replacement Engine (Not Available At This Printing)
741	697128	Gear-Timing			
750	790832	Screw (Oil Pump Cover)	1330	N/A	Repair Manual (Not Available At This Printing)
757	793242	Link-Counterweight			
758	793763	Counterweight	1332	591991	Washer (Rotating Screen)
759	697392	Pin-Counterweight			
773	796448	Retainer (Fuel Pump)			
783	693713	Gear-Pinion			
789	698329	Harness-Wiring			
797	693167	Nut (Brush Retainer)			
801	691283	Cap-Drive			
802	691286	Cap-End			
830	691095	Stud-Rocker Arm			
842	691031	Seal-O Ring (Dipstick)			
847	790442	Dipstick/Tube Assembly			
850	100106	Sealant-Liquid			
851	692424	Terminal-Spark Plug			
868	690968	Seal-Valve			
877	790544	Wire/Connector-Alternator			
883	692236	Gasket-Exhaust			
914	691108	Screw (Rocker Cover)			
918	791744	Hose-Vacuum (Cut to Required Length)			
943	690589	Seal-O Ring (Oil Pump Cover)			
947	699915	Solenoid-Fuel			
964	799159	Cap-Connector			
965	499613	Cover-Oil Pump			
967	793685	Filter-Pre Cleaner			
968	591644	Cover-Air Cleaner			
975	699502	Bowl-Fuel			
987	698777	Seal-Throttle Shaft			
1005	796084	Fan-Flywheel			
1017	796981	Screen-Oil Pump			
1022	272475s	Gasket-Rocker Cover			
1023	797421	Cover-Rocker			
1024	794644	Pump-Oil			
1026	692003	Rod-Push (Intake) (Aluminum)			
1026A	692011	Rod-Push (Exhaust) (Steel)			
1027	492932s	Filter-Oil			
1029	691751	Arm-Rocker			
1034	690822	Guide-Push Rod			
1036		Label-Emissions (Available from a B&S Authorized Dealer)			
1040	698368	Plate-Trim			
1044	698139	Screw (Flywheel)			
1051	691265	Ring-Retaining			
1058	277675	Operator's Manual			
1059	698516	Kit-Screw/Washer (Alternator)			
1090	691293	Retainer-Brush			
1091	691333	Cap-Limiter			
1095	794152	Gasket Set-Valve			
1119	691183	Screw (Alternator)			

Carburetor Overhaul Kit                      Key No. 121  
 Engine Gasket Set                              Key No. 358  
 Valve Gasket Set                                Key No. 1095

**NOTE:** All component dimensions given in U.S. inches  
 1 inch = 25.4 mm

---

# SERVICE NOTES

---

# Get it fixed, at your home or ours!

Just Call:

**1-800-4-MY-HOME<sup>®</sup>**

(1-800-469-4663)

24 hours a day, 7 days a week

For the repair of major brand appliances **in your own home...**  
no matter who made it, no matter who sold it!

For your nearest **Sears Parts and Service** location,  
to bring in products like vacuums, lawn equipment and electronics.

For **Sears Parts & Service**, to order the replacement parts,  
accessories and owner's manuals that you need to do-it-yourself.

[www.sears.ca](http://www.sears.ca)

---

To purchase or inquire about a Sears Maintenance Agreement, call:

**1-800-361-6665**

9 a.m. – 11 p.m. Mon. – Fri., EST, 9 a.m. – 4 p.m. Sat.

---

Pour service en français:

**1-800-LE-FOYER<sup>MC</sup>**

(1-800-533-6937)

[www.sears.ca](http://www.sears.ca)



® / <sup>TM</sup> Trademarks of Sears Brands Management Corporation used under license by Sears Canada

<sup>MD</sup> Marque déposée / <sup>MC</sup> Marque de commerce de Sears Brands Management Corporation utilisée en vertu d'une licence de Sears Canada



# Faites-le réparer, à domicile ou à l'atelier!

Téléphonez au:  
**1-800-LE-FOYER<sup>MC</sup>**  
(1-800-533-6937)  
24 heures par jour, 7 jours par semaine

Pour la réparation des appareils électroménagers de grandes marques  
**à votre domicile** ... peu importe le fabricant ou le détaillant!

Pour connaître l'emplacement du **Service des pièces et de l'entretien**  
**Sears** le plus proche afin d'apporter à l'atelier des produits tels que  
des aspirateurs, tondeuses à gazon ou appareils électroniques.

Pour connaître le no. de téléphone du **Service des pièces et de l'entretien**  
**Sears** afin de commander les pièces de rechange, accessoires et  
manuels d'instructions requis pour effectuer vous-même les réparations.

**www.sears.ca**

Pour acheter ou demander des renseignements  
sur un contrat d'entretien Sears, téléphonez au:  
**1-800-361-6665**

de 9 h à 23 h du lundi au vendredi (HNE), de 9 h à 16 h le samedi!

For service in English:  
**1-800-4-MY-HOME<sup>®</sup>**  
(1-800-469-4663)  
**www.sears.ca**





**TRACTEUR - - NUMÉRO DE MODÈLE 944.604180**  
**MOTEUR "BRIGGS & STRATTON" - NO. DE MODÈLE 33R777, NO. DE TYPE 0005-G1**

NO. DE PIÈCE	DESCRIPTION	NO. DE PIÈCE	DESCRIPTION
579	Ecroû	1034	Pousser le guide de tringle
584	Couverture	1036	Jeu d'étiquette (Fourni par un reven deur autorisé Briggs & Stratton)
601	Bride de Serrage de Tuyau	1040	Plaque
616	Epingle de goupille fendue	1051	Vis
617	Manivelle du Régulateur	1051	Annneau
633	Sceller l'anneau	1058	Manuel de l'opérateur
634	Sège de Arbre de Starter /	1059	Vis/Rondelle
635	Papillon	1090	Provision
634	Ressort	1091	Bouchon
654	Coude de Bougie d'allumage	1095	Fixée, Garnitures du Soupape
654	Ecroû	1119	Vis, Alternateur
684	Vis	1127	Vis, Cuve de Flotteur
691	Vis	1139	Rondelle
697	Vis	1263	Roseau de pause
697	Vis	1264	Vis
718	Goupille de Emplacement	1265	Support
718	Vis	1270	Annneau
729	Trombone de corde	1279	Contre poids bouche-audiovisuel
741	Vis	1329	Vis
750	Vis	N/A	Moteur de remplacement
757	Lien de contre poids	N/A	Réparer le Manuel
758	Contre poids	1332	Rondelle
759	Epingle de contre poids	591991	
773	Fixation de la pompe		
783	d'alimentation		
789	Ligoter l'engrenage		
797	Harnais		
797	Ecroû		
801	Bouchon		
802	Bouchon		
830	Bouchon		
842	Joint torique		
847	Ensemble des Tube et Jauge		
850	L'enduit d'étanchéité-liquide		
100106	de Rem plissage d'huile		
851	(Joint de Couverture de Bascule et le Joint de Pause)		
868	Borne, Bougie d'allumage		
877	Joint d'étanchéité, Soupape		
883	Corde/le connecteur-alternateur		
914	Garniture d'échappement		
918	Vis, Couverture de Balancier		
918	Flexible d'aspiration		
943	Annneau		
947	Solénoïde-carburant		
964	Chapeau		
965	Couverture		
967	Couverture		
968	Annneau		
975	Annneau		
987	Couverture		
987	Annneau		
1005	Cuve de Carburateur		
1017	Tamisé de pompe à huile		
1022	Ventilateur de Volant du Moteur		
1022	Garniture, Couverture de		
1023	Balancier		
1024	Couverture de Balancier		
1026	Annneau		
1027	Tige à Frein		
1027	Bouton		
1027	Huiler le filtre		
1029	Huiler le filtre		

**REMARQUE:** Toutes les dimensions de composant sont données en pouces E.-U. --1 pouce = 25,4 mm

La Série de Joint de moteur  
 La Série de Joint de soupape  
 La Trousse de Révision de carburateur  
 No. 358  
 No. 1095  
 No. 121

**TRACTEUR - - NUMÉRO DE MODÈLE 944.604180  
MOTEUR "BRIGGS & STRATTON" - NO. DE MODÈLE 33R777, NO. DE TYPE 0005-G1**

NO. DE PIÈCE	DESCRIPTION	NO. DE PIÈCE	DESCRIPTION
1	Ensemble du Cylindre	131	Etrangler la troussse d'arbre
2	Douille de Cylindre	133	Ens. de Flotteur de Carburateur
3	(Côté Magneto) Bague d'étanchéité	135	Tube d'essence
4	592849 Puisard de moteur (Côté Magneto)	141	Garniture du Flotteur
5	591750 Tête de Cylindre	187	Tuyau, Essence
7	794114 Garniture de la Tête de Cylindre	188	Vis, Support de Control
9	697109 Joint-pause (Joint Liquide et le	192	Balancier de Réglage
		202	Gouverneur mécanique
		209	Ressort, Régulateur
11	794683 TUBE de Renfflard Interchangeables)	216	Etourffer le lien
12	697110 Garniture du Carter-moteur	217	Ressort
13	592244 Vis de Tête de Cylindre	222	Support du Carburateur
15	690946 Bouchon de vidange	227	Ensemble du Levier de Régulateur
16	591762 Vilbrequin	232	Ressort
20	795387 Bague d'étanchéité (Côté PTO)	238	Bouchon de soupape
22	692125 Vis de Montage de Bac à Sems	240	Alimenter le filtre
23	591759 Volant Magneto	265	Serre-joint
24	591757 Clé de Volant	267	Vis
25	795858 Ensemble du Piston, Standard	276	Rondelle
26	794126 Jeu des Segments de Piston, Std.	304	Boîtier de Soufflerie
		305	Vis (Carter de ventilateur)
27	698469 Verrou de l'axe de Piston	305A	799370 Vis (Carter de ventilateur)
28	795861 Axe de Piston	305B	795891 Vis (Carter de ventilateur)
29	794122 Ensemble de la Bielle	305C	799370 Vis (Carter de ventilateur)
32	791118 Vis de Bielle		
33	591752 Soupape d'échappement		
34	591751 Soupape d'admission		
35	691279 Ressort de Soupape d'admission		
36	691279 Ressort de Soupape		
37	699882 Garde de volant	310	Vis
42	499586 Guide à Soupape	311	Jeu de balais
43	691968 Gouverneur/huile	324	Assemblée de trie/fasse
45	690564 Poussoir à Soupape	333	Armature de Magneto
46	793880 Engrenage de Came	334	Vis de Armature de Magneto
48	N/A Bloc Court	337	Bougie d'allumage
50	690193 Prise diverse	358	Jeu de la Garniture de Moteur
51	692137 Garniture de Coude d'admission	377	Clé
51A	796081 Garniture de Coude d'admission	404	Rondelle
53	591260 Std (Carburetor)	415	Bouchon
54	691148 Vis	415A	Bouchon
55	691148 Vis	431	Coude de prise
78	691693 Vis	445	Aérer la cartouche de filtre
94	793610 Trousse de poulie de tension	462	Rondelle
95	690718 Vis à Sems de Montage de	474	Alternateur
98	695408 Jeu de Vitesses à Vide	503	Démarrreur sanglé
104	694918 Axe de Charnière de Flotteur	505	EcroU de Levier de Régulateur
105	696136 Soupape de Aiguille	510	Drive-Starteur
108	695419 Soupape à Starter	513	Conduire l'embrayage
117	796251 Giclette, Standard	523	Jauge de Remplissage d'huile
118	791406 Giclette, Altitude Haute	524	Joint d'étanchéité, Tube de
121	796184 Jeu de Carburateur	525	Remplis sage d'huile
125	591736 Carburateur	697184	Tube de Remplissage d'huile
127	690727 Rondelle Obturatrice	697144	Douille, Manivelle du Régulateur
130	792747 Soupape de Commande des Gaz	562	Boulon de Levier de Régulateur

**TRACTEUR - - NUMÉRO DE MODÈLE 944.604180**  
**MOTEUR "BRIGGS & STRATTON" - NO. DE MODÈLE 33R777, NO. DE TYPE 0005-G1**

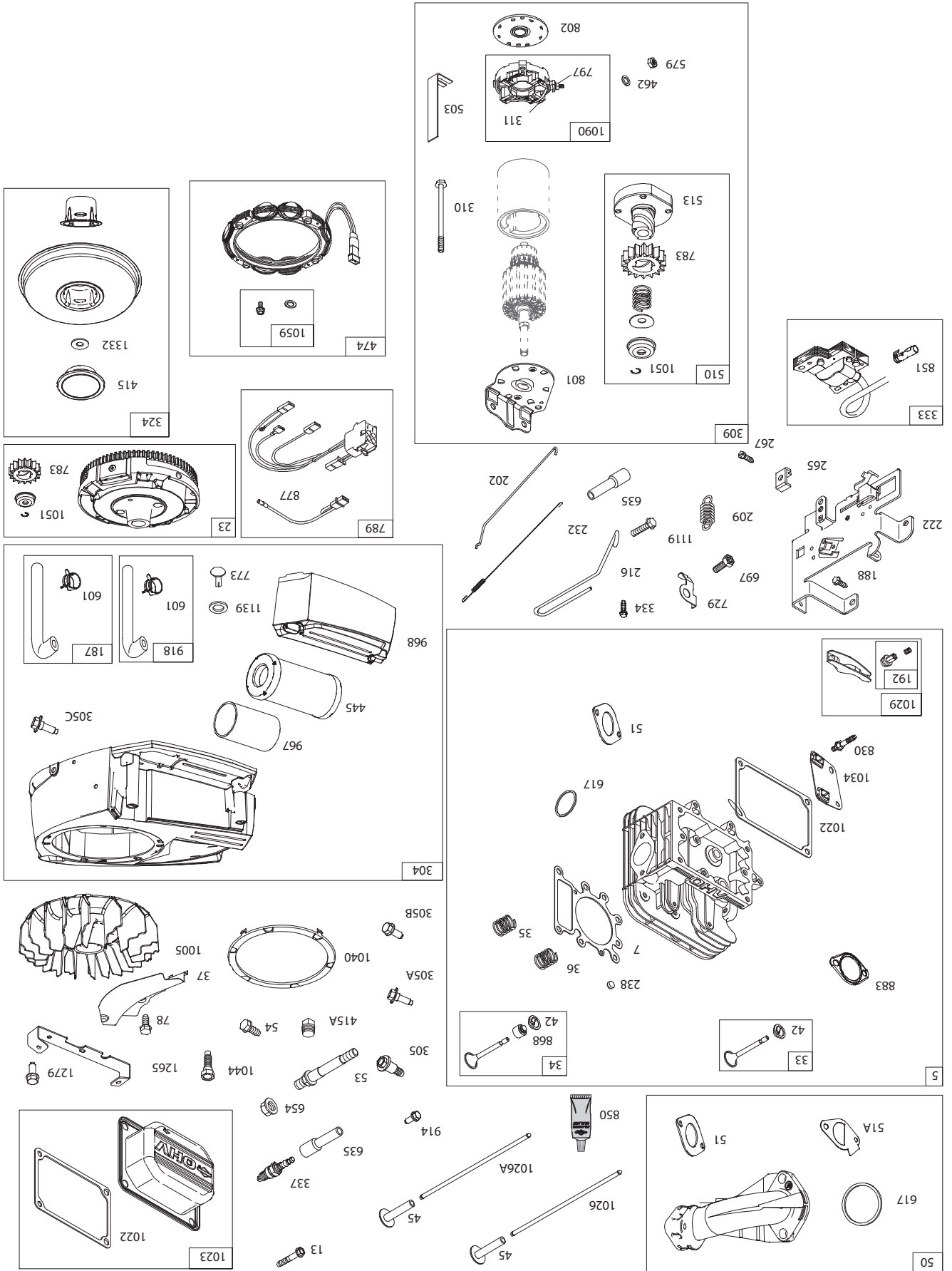

**TRACTEUR - - NUMÉRO DE MODÈLE 944.604180 - NO. DE MODÈLE 33R77, NO. DE TYPE 0005-G1**

1329 MOTEUR DE RECHANGE

1058 MANUEL DE L'OPÉRATEUR

1036 EMISSIONS ETIQUETÉ

48 BLOC COURT

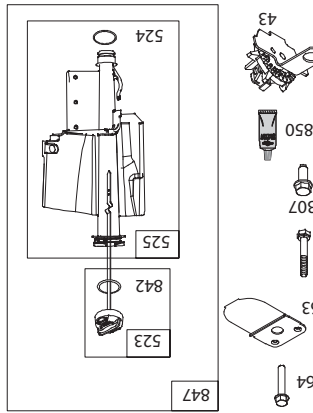
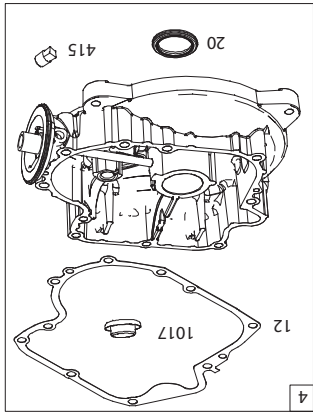
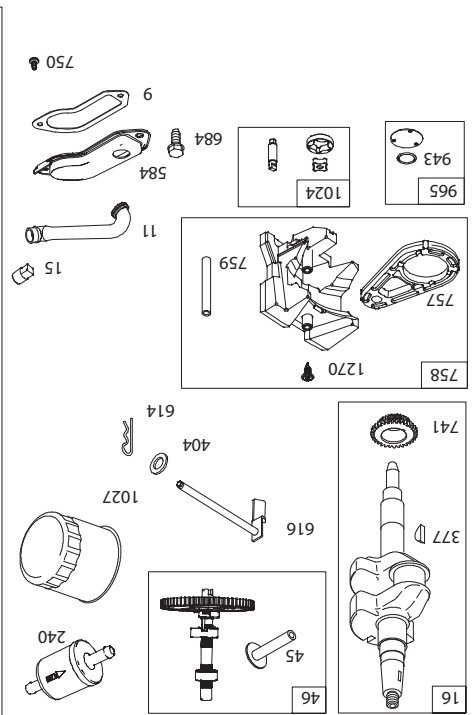
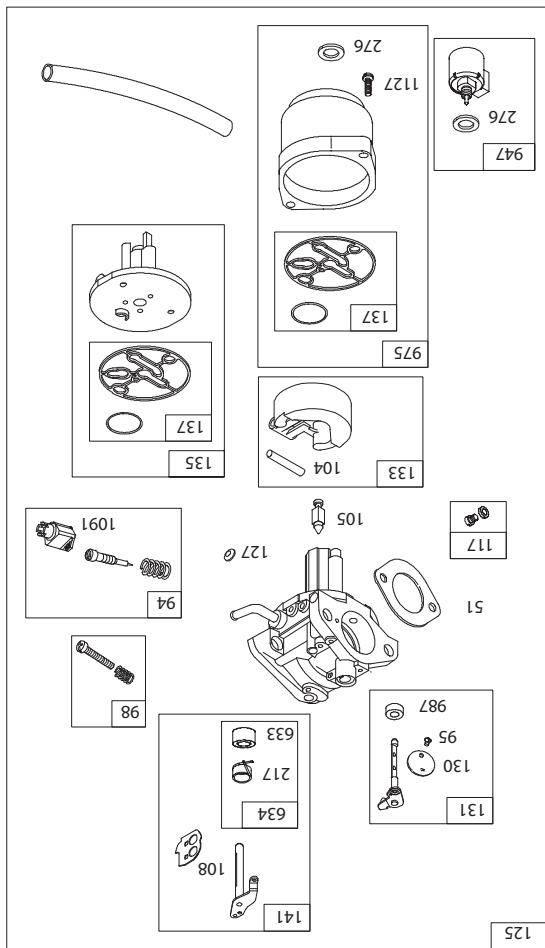
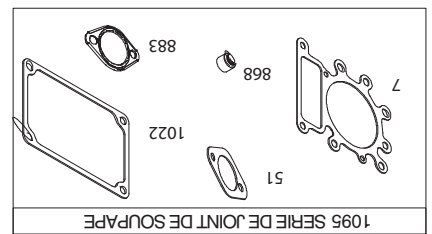
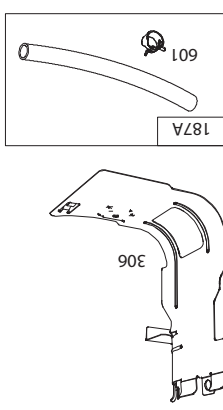
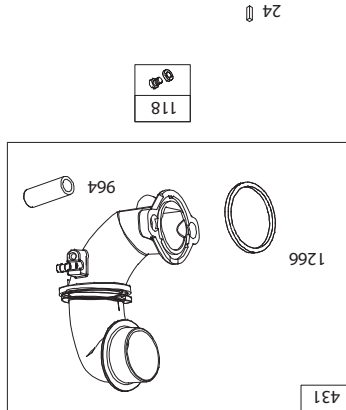
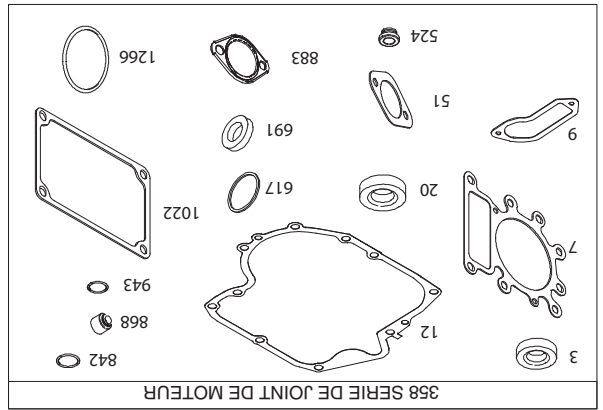
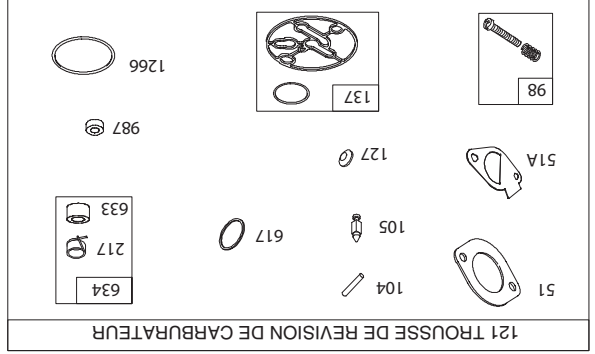
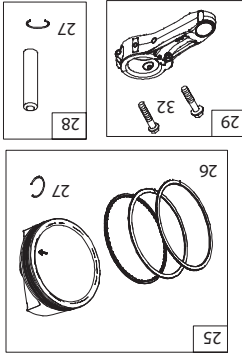
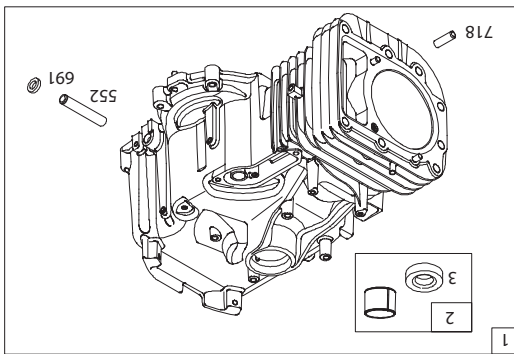

# TRACTEUR - - NUMÉRO DE MODÈLE 944.604180

## DÉCALCOMANIES

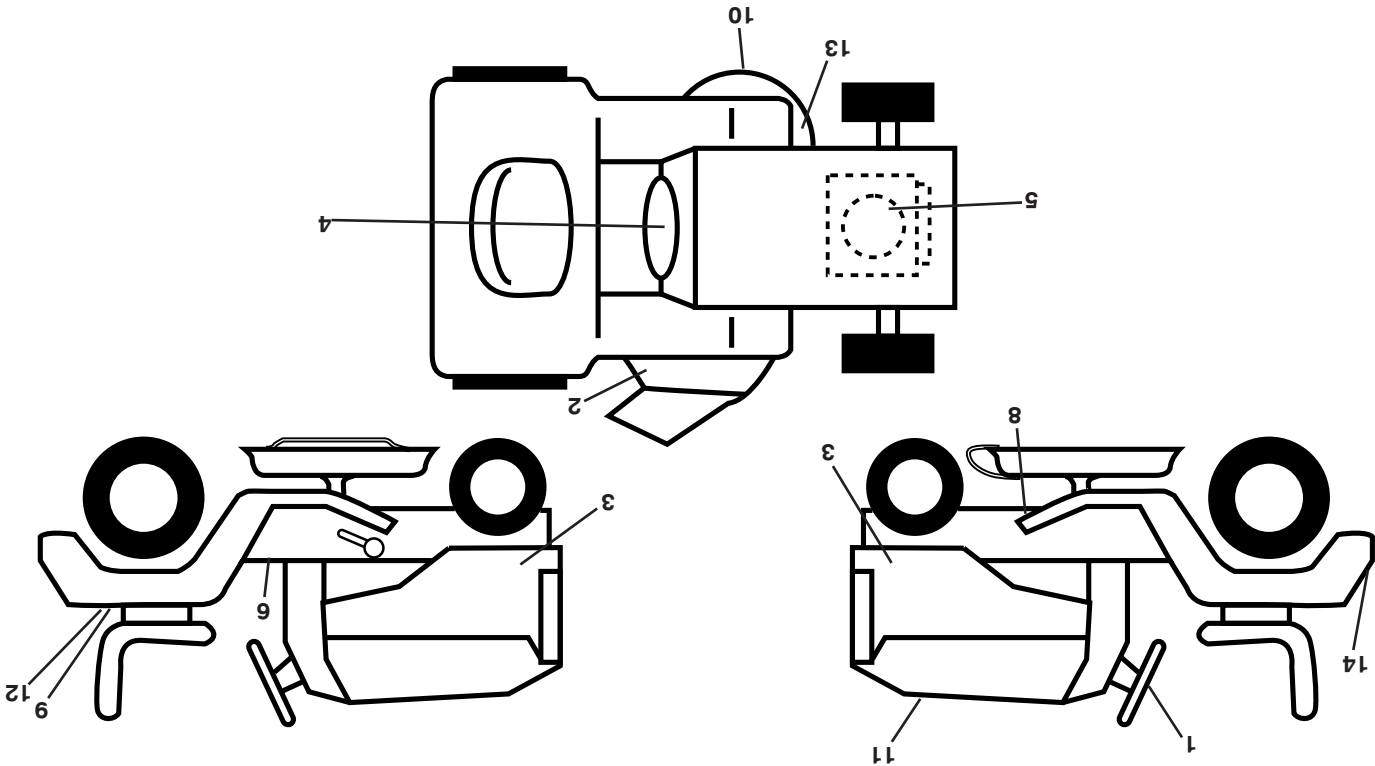

NO. NO  
DÉ DÉ  
REF PIÈCE

DESCRIPTION

1	439525	Décalcomanie, Volant de direction
2	581579501	Décalcomanie, Avertissement du tondeuse
3	586642501	Décalcomanie, Tableau (C.D.\C.G.)
4	581579901	Décalcomanie, De pare - étincelles
5	586620801	Décalcomanie, Moteur
6	581579001	Décalcomanie, Pare-chocs
8	421534	Décalcomanie, Schématique du Cour-rolie "V" d'entraînement
9	149517	Décalcomanie, Batterie
10	426593	Décalcomanie, Tracteur Cooper
11	586620901	Décalcomanie, Remplacement

NO. NO  
DÉ DÉ  
REF PIÈCE

DESCRIPTION

12	448709	Décalcomanie, Batterie
13	581580001	Décalcomanie, Schématique du Cour-rolie "V" du tondeuse
14	441122	Décalcomanie, L'aile
--	581724801	Décalcomanie, Dérivation
--	193226X428	Coussin de repose-pied (C.G.)
--	400981X428	Garniture, pédale de pied
--	586644024	Manuel de L'Opérateur
--	586644032	Manuel des Pièces de Rechange (Anglais/Français)

## PNEU

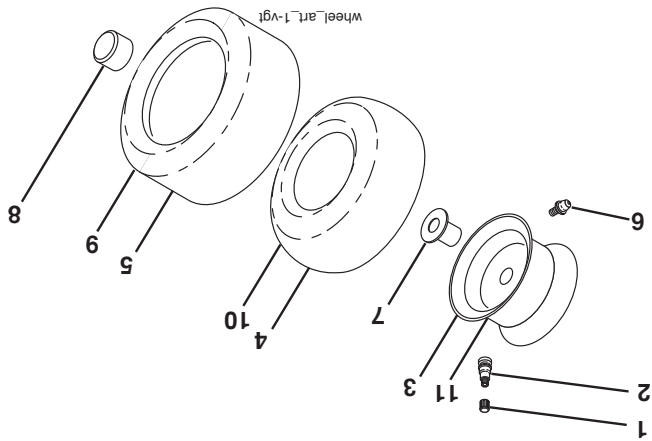

NO. NO  
DÉ DÉ  
REF PIÈCE

DESCRIPTION

1	59192	Chapeau de soupape du pneu
2	65139	Tuyau du soupape
3	106732X613	Assemblage de la jante antérieure
4	59904	Chambre à air antérieure
5	106222X	Pneu antérieur 15 x 6-6
6	278H	Graisseur
7	9040H	Palier à collerette
8	104757X613	Chapeau de l'essieu (Roue antérieure seulement)
9	138468	Pneu arrière 20 x 8-8
10	7152J	Chambre à air arrière
11	106108X613	Assemblage de la jante arrière
--	144334	Joint d'étanchéité de pneu (tube de .30L [10 oz. Tube])

REMARQUE: Toutes les dimensions de composant sont données en pouces E.-U. --1 pouce = 25,4 mm

# TRACTEUR -- NUMÉRO DE MODÈLE 944.604180

## ENSEMBLE DU SIÈGE

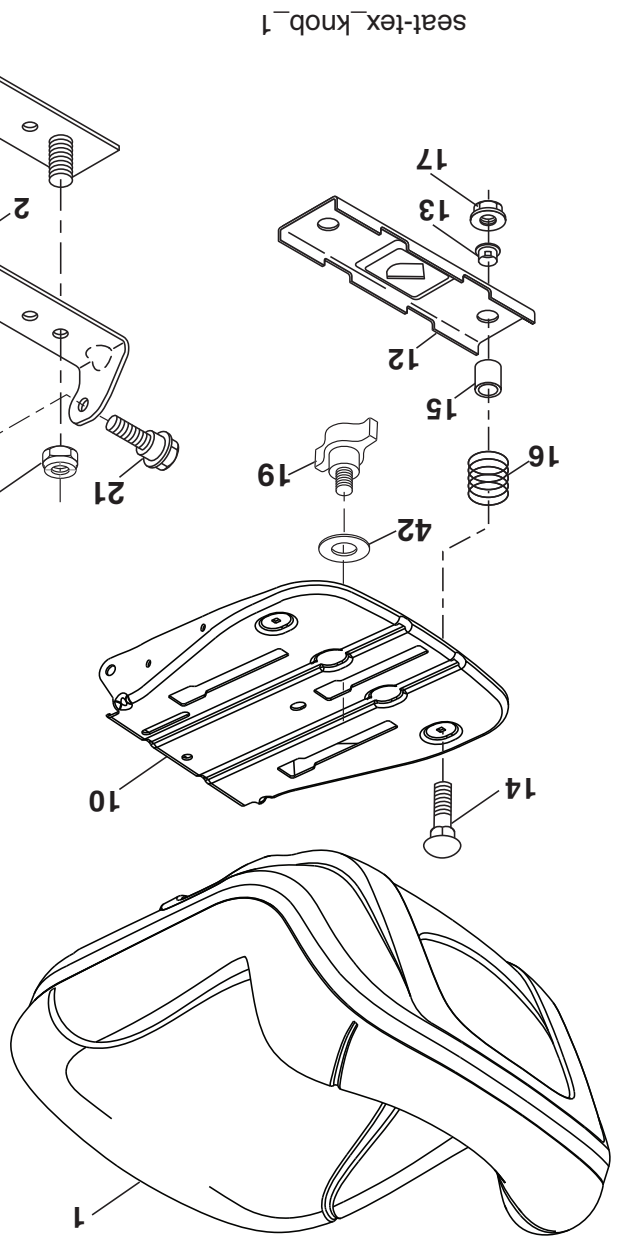

NO.	DÉ	PIÈCE
1	423644	Siège
2	180166	Support de pivot
3	140675	Support de siège
5	145006	Pince
6	73800600	Contre-écrou avec rondelle insert 3/8-16
7	124181X	Ressort de compression du siège
8	171877	Boulon 5/16-18 unc x 3/4
10	441805	Panneau du siège
12	199370	Support
13	121248X	Coussinet
14	72050412	Boulon 1/4-20 x 1-1/2

### DESCRIPTION

NO.	DÉ	PIÈCE
15	134300	Entretoise
16	123740X	Ressort
17	123976X	Écrou 1/4
19	199372	Bouton
21	171852	Boulon 5/16-18
37	73800500	Contre-écrou 5/16-18
42	199371	Rondelle

### DESCRIPTION

**REMARQUE:** Toutes les dimensions de composant sont données en pouces E.-U. -- 1 pouce = 25,4 mm



**TRACTEUR -- NUMÉRO DE MODÈLE 944.604180**  
**LEVAGE DE LA TONDEUSE**

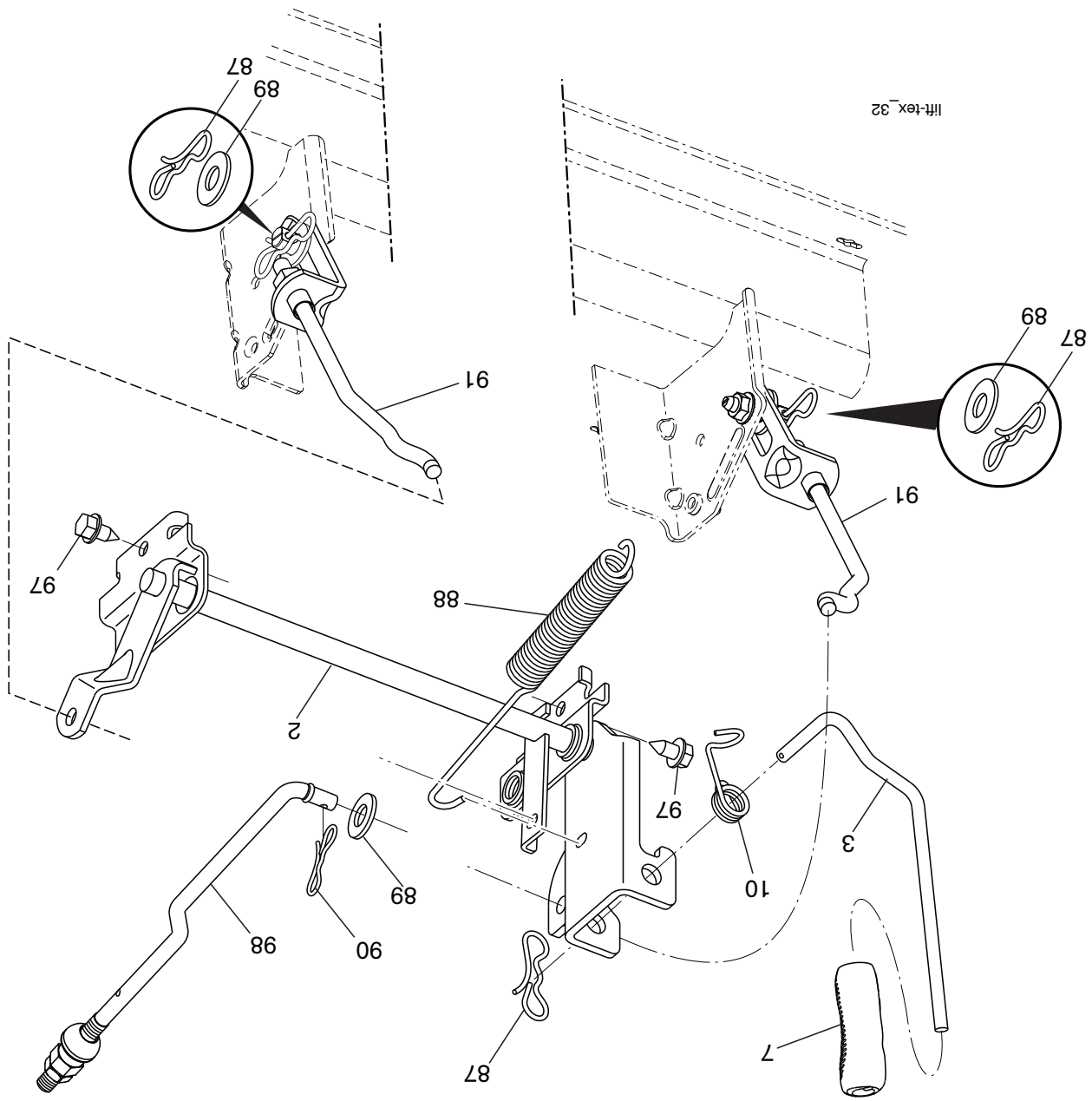

NO.	DÉ	PIÈCE	DESCRIPTION
2		422027	Ensemble de l'arbre
3		195231	Levier de levage (C.D.)
7		445060X428	Poignée du levier
10		196314	Ressort de torsion
87		194209	Goupille fendue 7/16
88		410710	Ressort du levage
89		19191912	Rondelle 17/32 x 1-3/16 x 12 Ja.
90		194208	Goupille fendue 5/16
NO.	DÉ	PIÈCE	DESCRIPTION
91		197984	Tige de levage (C.G.)
97		1700612	Vis 3/8-16 x 3/4
98		420525	Tige de levage du suspension avant

**REMARQUE:** Toutes les dimensions de composant sont données en pouces E.-U. --1 pouce = 25,4 mm

# TRACTEUR - - NUMÉRO DE MODÈLE 944.604180

## CARTER DE TONDEUSE

NO. DÉ	REF. PIÈCE	DESCRIPTION	NO. DÉ	REF. PIÈCE	DESCRIPTION
1	196495	Tondeuse du gazon	62	72110616	Boulon 3/8-16 unc x 2
6	195186	Tige du suspension	63	199477	Tige du frein du tondeuse
7	416358	Vis 10 x .750	64	199790	Tige du frein
8	193003	Boulon/Rondelle 7/16-20 untf	67	198398X428	Poignée du câble de commande
11	424752	Lame, 107 cm 3NI	68	429636	Courroie de tondeuse
--	422719	Lame, 107 cm SF 3NI	69	72140505	Boulon 5/16-18 x 5/8
--	139775	Lame de broyeuse supérieure	70	401246	Assemblage d'embrayage
--	138971	Lame de tondeuse	113	17000510	Boulon 5/16-18
13	192872	Assemblage d'arbre du mandrin	116	4898H	Boulon
14	187281	Boîtier de mandrin	117	188606	Mesure de roue
15	110485X	Palier du mandrin	119	19121414	Rondelle
19	196539	Boulon	122	197258	Garde du courroie (C.G.)
20	159770	Chicane	123	197259	Garde du courroie (C.D.)
21	73680500	Ecroû 5/16-18 unc	144	199204	Garde du courroie
23	192557	Support de déflecteur	145	193197	Pouille de tension
24	105304X	Chapeau	147	401971	Ressort de retour
25	197026	Ressort	152	584243501	Câble d'embrayage avec ressort
26	110452X	Ecroû	188	195161	Attache à tenon
27	424469	Déflecteur	189	73900500	Contre-écrou collerette
29	131491	Tige d'articulation	192	197260	Support (C.G.)
30	173984	Vis	195	17000612	Vis 3/8-16 x 3/4
31	187690	Rondelle d'entretoise	241	152927	Vis #10-32.5. 3/8
32	197473	Pouille de mandrin	242	415598	Raccord de levage
33	400234	Ecroû	--	416405	Connecter d'accouplement du rapide
34	72110612	Boulon 3/8-16 x 1-1/2 Cat. 5	--	192870	Assemblage du mandrin (inclut boîtier
36	197379	Pouille de gallet-tendeur	--	192870	(#14), ensemble arbe (#13), et palier
37	19131316	Rondelle	--	192870	seulement (#15) et écrou (#33)- pou-
38	432520	Garde de courroie	--	192870	lie/rondelle et lame, boulon/rondelle
40	73900600	Ecroû 3/8-16 unc	--	192870	n'est pas inclus)
42	198410	Ressort de torsion du frein	--	425415	Tondeuse du gazon pour remplace-
43	197256	Ressort de torsion de retenue	--	425415	ment, Complète
46	137729	Vis 1/4-20 x 5/8	--	425415	
47	197250	Support du câble de commande	--	425415	
55	437110	Tige	--	425415	
56	199092	Entretoise de retenue	--	425415	
57	17000616	Vis 3/8-16 x 1	--	425415	
59	141043	Garde de pouille	--	425415	
60	197261	Tige du frein du tondeuse	--	425415	

**REMARQUE:** Toutes les dimensions de composant sont données en pouces E.-U. -- 1 pouce = 25,4 mm.

**TRACTEUR - - NUMÉRO DE MODÈLE 944.604180**

**CARTER DE TONDEUSE**

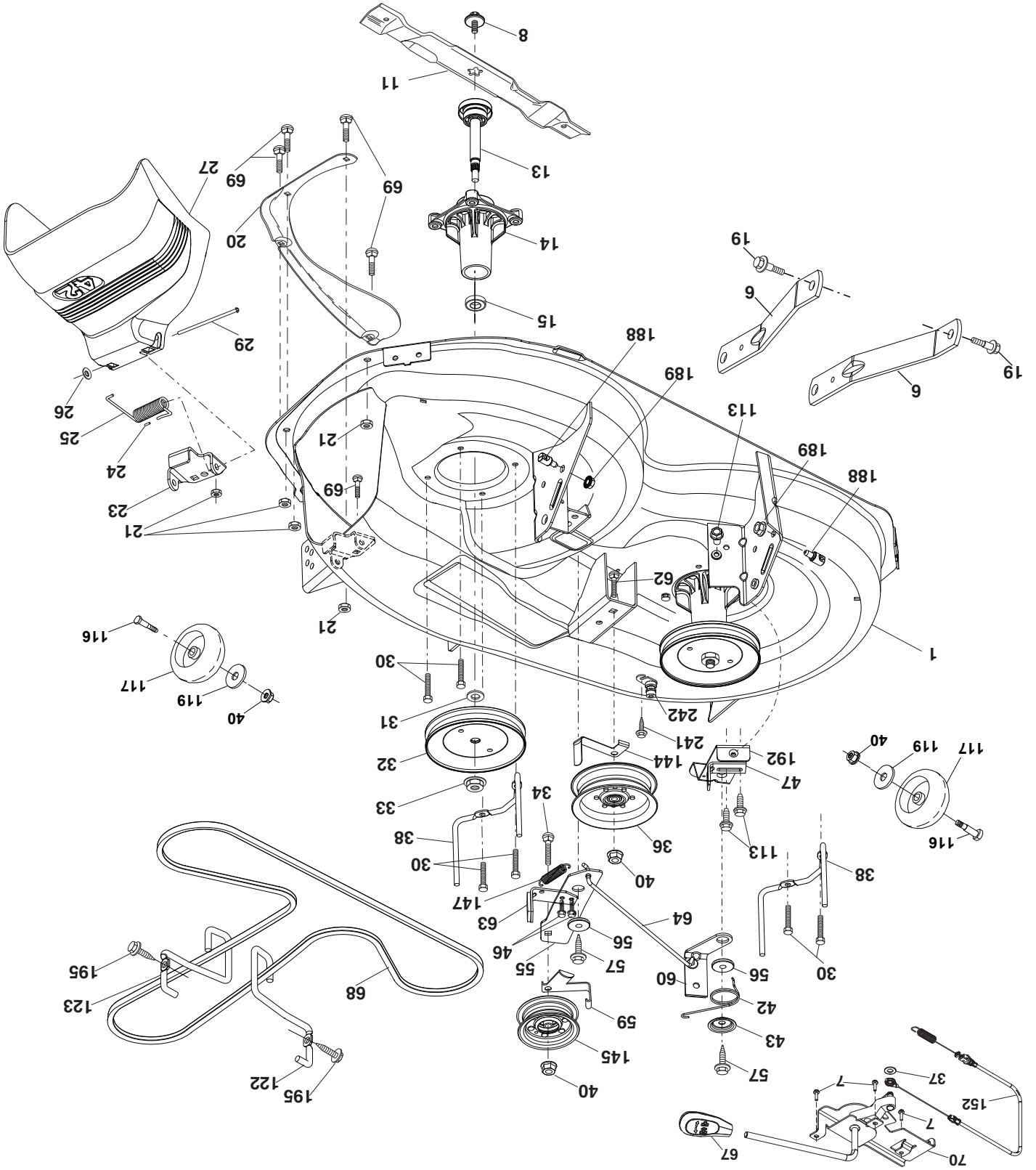

**TRACTEUR - - NUMÉRO DE MODÈLE 944.604180**  
**ENSEMBLE DE LA DIRECTION**

NO.	DE	NO.	DESCRIPTION
1		414803X428	Volant de direction
2		436870	Axe avant Asmblly
4		436873	Ensemble de la broche C.G.
5		436874	Ensemble de la broche C.D.
6		6266H	Rondelle clip n°T5304-75
7		121748X	Rondelle 25/32 x 1-5/8 x 16 Ja.
8		1200029	Anneau d'agrafe #T5304-75
9		184946X667	Spindle Cape
13		121749X	Rondelle
14		10040600	Rondelle 3/8
15		73540600	Ecrou 3/8-24 unt
16		441456	Arbre de direction
19		194729	Arbre de plaque
20		400803X428	Boîte de direction
21		437747	Adapteur de volant
22		194845	Douille
26		414852X428	Insertion de volant
28		17000612	Vis 3/8-16 x 3/4
33		10040500	Rondelle 5/16
35		440770	Vitesses de plat de secteur
45		19113812	Rondelle
53		188967	Rondelle .793 x 1.637 x .060
57		407465	Support
58		194747	Boulon
59		194748	Rondelle
60		73971000	Ecrou 5/8-11
61		436884	Tige, C.G.
62		436885	Tige, C.D.
63		17000512	Vis 5/16-18 x 3/4
64		199849	Ressort
66		71020748	Boulon 7/16-14 x 3 Serr
67		194737	Douille
68		73900700	Ecrou 7/16-14 cat. 5
69		199162	Rondelle 1.5 x .505 x .118
70		196197	Support
71		190752	Arbre de direction
72		428982	Boulon 5/16-18 x 4
80		1370H	Rondelle
81		436887	Réticulation C.G.
82		442147	Pivot Boulon
85		441873	Pivot C.G.
86		441872	Pivot C.D.
118		406013	Douille
122		444962	Chapeau

**REMARQUE:** Toutes les dimensions de composant sont données en pouces E.-U. --1 pouce = 25,4 mm

**TRACTEUR - - NUMÉRO DE MODÈLE 944.604180**  
**ENSEMBLE DE LA DIRECTION**

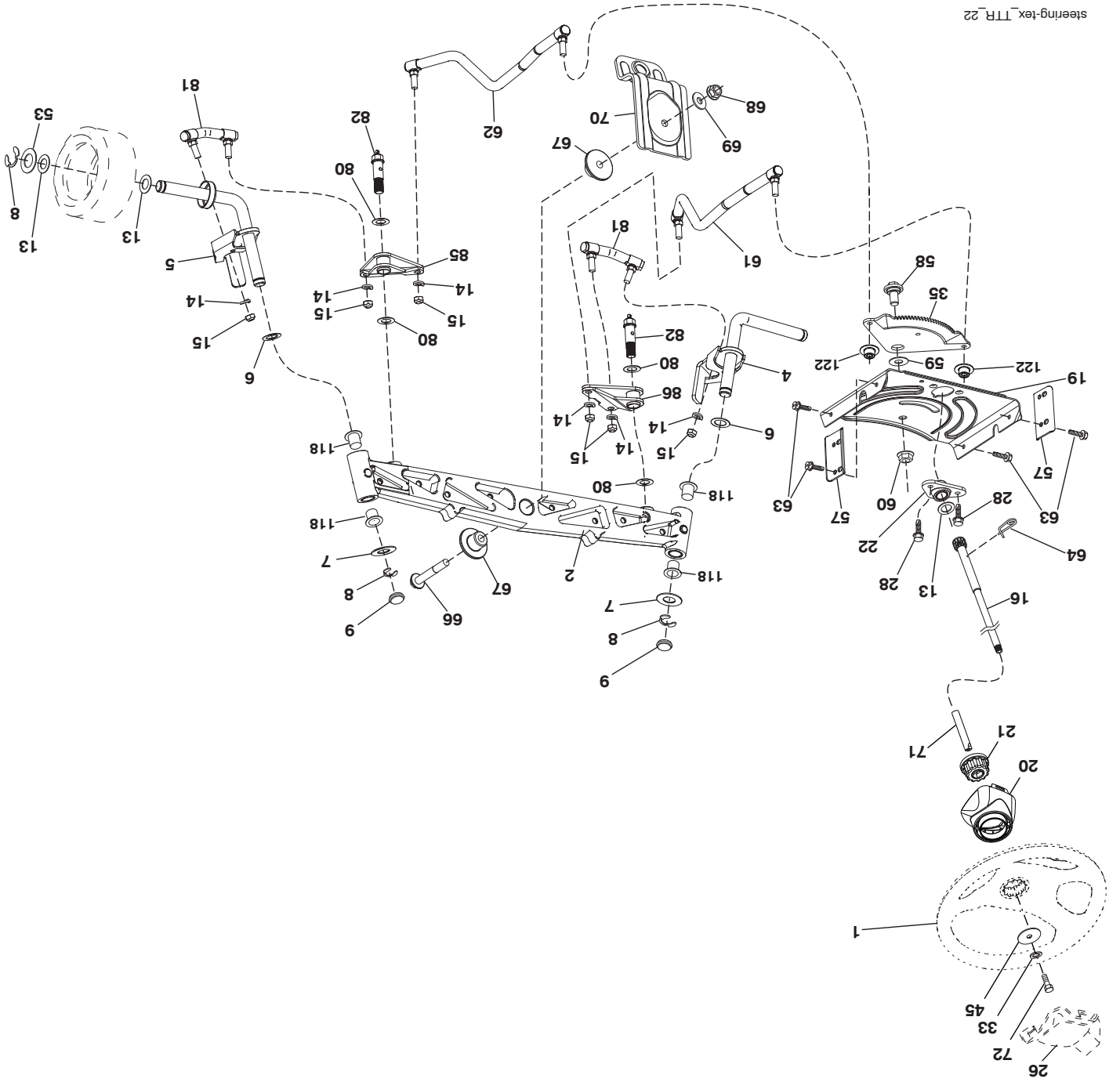

steering-tex\_TTR\_22

# TRACTEUR - - NUMÉRO DE MODÈLE 944.604180

## MOTEUR

NO.	DÉ	REF.	DESCRIPTION
NO.	DE	PIECE	
1	-	-	Moteur B&S No. de modèle 33R777-0005-G1 (586306801)
2	580532301		Silencieux
9	194319		Garde du courroie du moteur
12	401985		Pouille du moteur
15	581289901		Réservoir d'essence
18	430220		Chapeau d'essence
20	170545		Commande des gaz et l'étrangleur
21	416358		Vis 10 x .750
28	137040		Conduite d'essence
29	137180		Jeu de pare - étincelles
37	123487X		Collier de serrage pour tuyaux flexibles
42	10040700		Rondelle 7/16
45	73510400		Ecrou 1/4-20 unc
69	165291		Garniture
79	192334		Vis 5/16-18 x .75
81	148456		Bec de vidange d'huile
82	428287		Vidange d'huile
84	17060620		Vis 3/8-16 x 1-1/4
85	173937		Boulon 7/16-20 x 4 x Cat. 5-1.5
87	171877		Boulon 5/16-18 x 3/4 w/Sems
90	17000616		Vis 3/8-16 x 1.0
94	581880901		Tube d'échappement
96	19091416		Rondelle 9/32 x 7/8 x 16 Ja.
97	17670412		Vis 1/4-20 x 3/4

**REMARQUE:** Toutes les dimensions de composant sont données en pouces E.-U. -- 1 pouce = 25,4 mm

### Informations concernant la puissance théorique du moteur

La puissance brute pour chaque Modèle de moteur à essence est indiquée conformément au code J1940 (procédure de calcul de la puissance et du couple des petits moteurs) de la SAE (Society of Automotive Engineers) et les performances théoriques ont été obtenues et corrigées selon SAE J1995 (révision 2002-05). Les valeurs de couple sont calculées sur la base de 3060tr/min et celles de puissance sur la base de 3600tr/min. La puissance brute réelle du moteur peut être plus faible notamment à cause des conditions de fonctionnement et des variations d'un moteur à l'autre. Compte tenu de la grande variété de machines sur lesquelles nos moteurs sont utilisés et du nombre de problèmes environnementaux applicables au fonctionnement des équipements, il se peut que le moteur à essence ne développe pas sa puissance théorique une fois qu'il est monté sur une machine particulière (puissance nette ou réelle «sur site»). Cette différence s'explique par un grand nombre de facteurs, tels que (liste non limitative): accessoires (filtre à air, échappement, admission, refroidissement, carburateur, pompe à essence, etc.), limites d'utilisation, conditions ambiantes (utilisation (température, humidité, altitude) et variations d'un moteur à l'autre. Pour des raisons de fabrication et de capacité limitées, Briggs & Stratton est susceptible de remplacer ce Modèle par un moteur plus puissant.

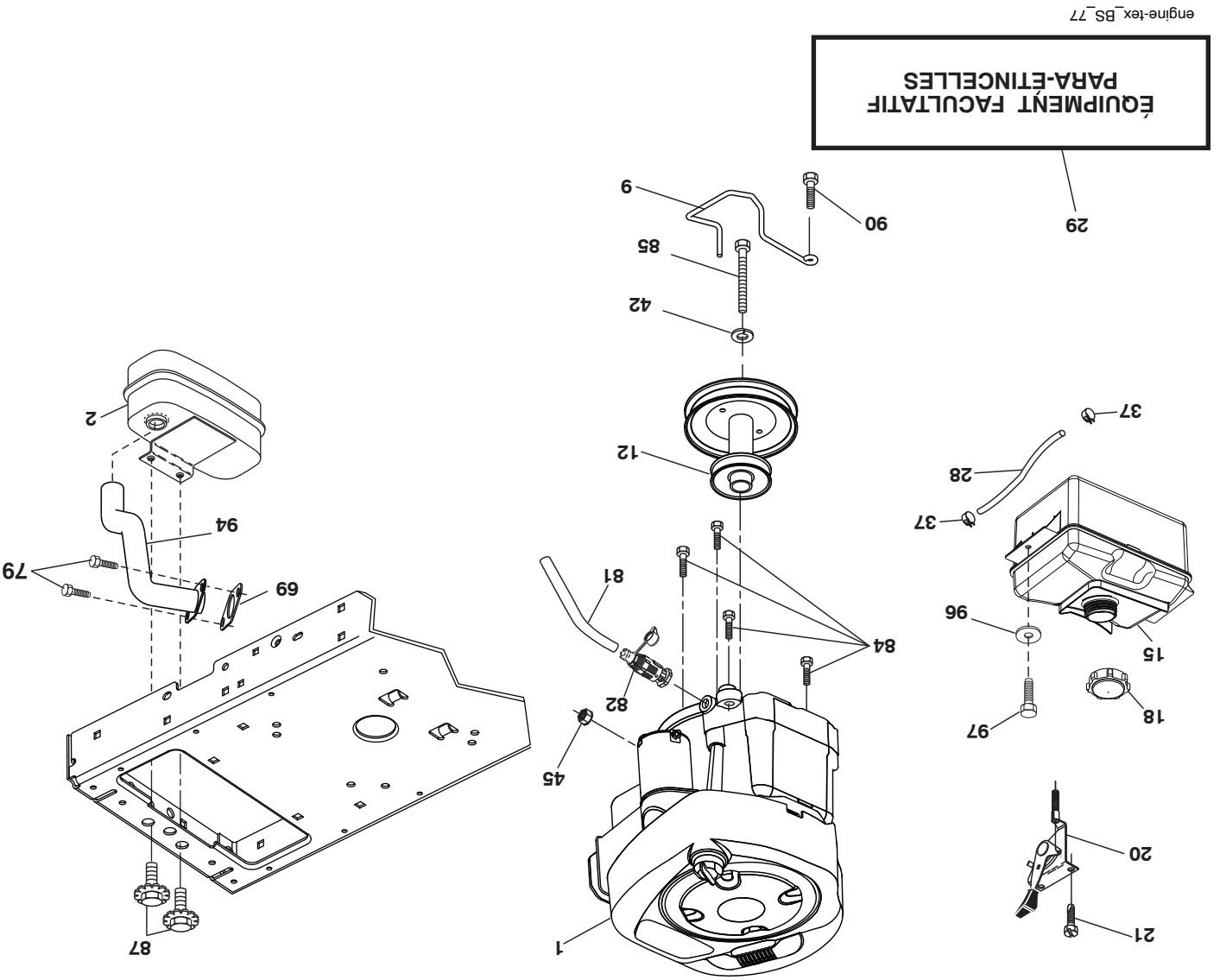

# TRACTEUR - - NUMÉRO DE MODÈLE 944.604180

## ENTRAÎNEMENT

NO.	DE	PIÈCE	REF.	DESCRIPTION	NO.	DE	PIÈCE	REF.	DESCRIPTION
1	---	---	---	Transmission, Gétrans (580486201)	2	123583X	Ciè 2,0 x .1845/.1865	190	194318
5	74760636	Ecron	195	581504601	5	74760636	Ecron	190	194317
6	124028X	Bague	203	191111116	6	124028X	Bague	188	194323
15	19131316	Rondelle 13/32 x 13/16 x 16 Ja.	205	121748	17	584954001	Ressort du frein	187	19133210
17	584954001	Ressort du frein	210	448270	18	194317	Ensemble Du Levier Coude	187	19133210
29	584823101	Tige du frein	211	120183X	189	194317	Raccord d'embranchage	188	194323
33	12000001	Bague en E #5133-75	214	421263	195	581504601	Support du frein	188	194323
35	401031	Tige frein de stationnement	215	448254	195	581504601	Garde de Poullie	187	19133210
37	188967	Rondelle	221	403187	205	121748	Rondelle 25/32 x 11-5/8 x 16 Ja.	187	19133210
42	8883R	Couverture de la pédale	222	79212010	205	121748	Rondelle 11/32 x 11-5/8 x 16 Ja.	187	19133210
49	72110614	Boulon 3/8-16 unc x 1-3/4 cat. 5	277	448500	210	448270	Assemblage de la pédale	187	19133210
50	194327	Poullie du galet-tendeur	282	74490548	210	448270	Assemblage de la pédale	187	19133210
51	73900600	Ecron 3/8-16	299	415683	210	448270	Assemblage de la pédale	187	19133210
52	194326	Galet-Tendeur	300	415681	210	448270	Assemblage de la pédale	187	19133210
56	197253	Courroie	301	415680	210	448270	Assemblage de la pédale	187	19133210
64	448353	Pédale de frein	302	581420501	210	448270	Assemblage de la pédale	187	19133210
67	19131312	Rondelle 13/32 x 13/16 x12 Ja.	303	72110618	210	448270	Assemblage de la pédale	187	19133210
73	74490544	Boulon 5/16-18 cat.5	306	76020416	210	448270	Assemblage de la pédale	187	19133210
99	435935	Tige De Dérivation	345	72110606	210	448270	Assemblage de la pédale	187	19133210
116	73900500	Ecron 5/16-18 unc	373	581461801	210	448270	Assemblage de la pédale	187	19133210
125	17000512	Vis 5/16-18 x 3/4	374	581475201	210	448270	Assemblage de la pédale	187	19133210
143	17490508	Vis 5/16-18 x 1/2	375	73680600	210	448270	Assemblage de la pédale	187	19133210
159	76020412	Axe de chape	378	584287701	210	448270	Assemblage de la pédale	187	19133210
160	169484	Pince D' Arrêt, Collier De Retenue			210	448270	Assemblage de la pédale	187	19133210
161	105709X	Ressort De Rappel			210	448270	Assemblage de la pédale	187	19133210
163	583971301	Tige			210	448270	Assemblage de la pédale	187	19133210
166	429164	Ecron .625			210	448270	Assemblage de la pédale	187	19133210
167	405257	Loquet			210	448270	Assemblage de la pédale	187	19133210
172	583974201	Attache De Torsion			210	448270	Assemblage de la pédale	187	19133210
184	199996X667	Guidon			210	448270	Assemblage de la pédale	187	19133210
185	72110622	Boulon 3/8-16 unc x 2-3/4 cat.5			210	448270	Assemblage de la pédale	187	19133210
186	194321	Entretoise			210	448270	Assemblage de la pédale	187	19133210

**REMARQUE:** Toutes les dimensions de composant sont données en pouces E.-U. -- 1 pouce = 25,4 mm



TRACTEUR - - NUMÉRO DE MODÈLE 944.604180

ENTRAÎNEMENT

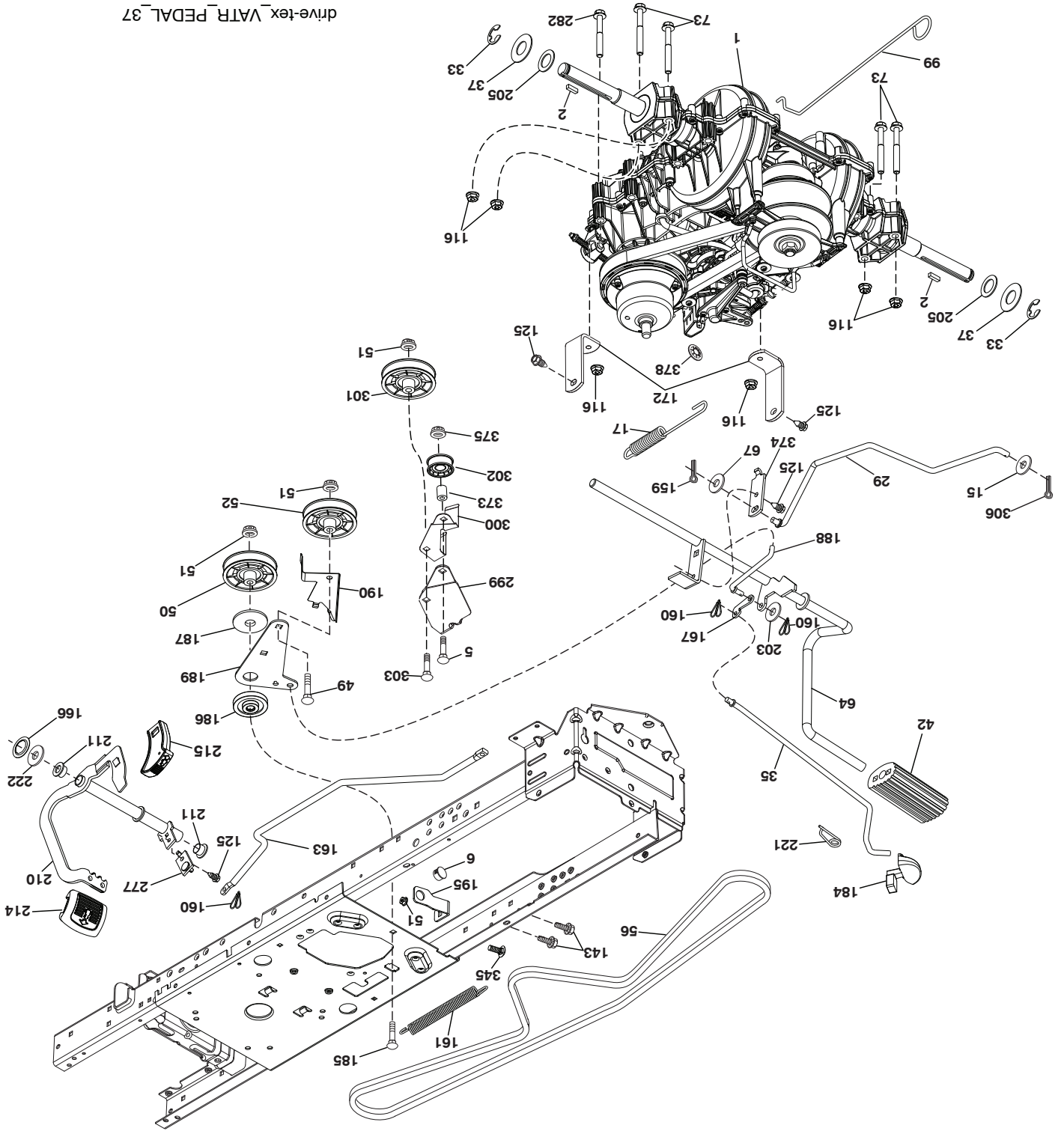

drive-tex\_VATR\_PEDAL\_37

**TRACTEUR - - NUMÉRO DE MODÈLE 944.604180**  
**CHÂSSIS/ENCEINTES**

NO. DE DÉ	RÉF. PIÈCE	DESCRIPTION
5	400801X428	Tableau de bord
14	198416X428	Capot
18	580427601	Grille
34	580910801	Plaque
36	17060512	Vis 5/16-18 x 3/4
37	414879X428	Fender
52	73680500	Écrou 5/16-18
58	412280	Barre d'attelage
68	17490508	Vis 5/16-18 x 1/2
130	416358	Vis #10 x 0.750
138	193224X428	Support De Tasse
150	400267	Conduit d'entrée d'air
151	187568	Support
152	199535	Bouclier de débris
153	400550X599	Lentille
159	17000612	Vis 3/8-16 x 3/4
162	142432	Vis 1/4 x 1/2
175	199472	Traverse
176	400776	Vis 10-24 x 5/8
177	195228	Coussinet
180	415063	Châssis
181	193102X428	Coussinet
182	407176	Tableau du bord inférieur
183	74520520	Boulon 5/16-18 x 1-1/4
189	17000512	Vis 5/16-18 x 3/4
191	416502	Insert (C.G.)
194	73900500	Écrou 5/16-18
196	414579	Assemblage du console
202	580427401	Évente (C.D.)
203	580427501	Évente (C.G.)
213	74760512	Boulon 5/16-18 x 3/4
217	409167	Tige
218	196395	Capot support d'arrêt
225	400549X615	Coussin
228	195161	Attache à tenon
235	406129	Entrée du pare-chocs
236	73930500	Écrou 5/16-18
237	403704	Bouchon
287	17600406	Vis 1/4-20 x 3/8
297	401827	Insert (C.D.)

**REMARQUE:** Toutes les dimensions de composant sont données en pouces E.-U. -- 1 pouce = 25,4 mm

**TRACTEUR - - NUMÉRO DE MODÈLE 944.604180**

**CHÂSSIS/ENCEINTES**

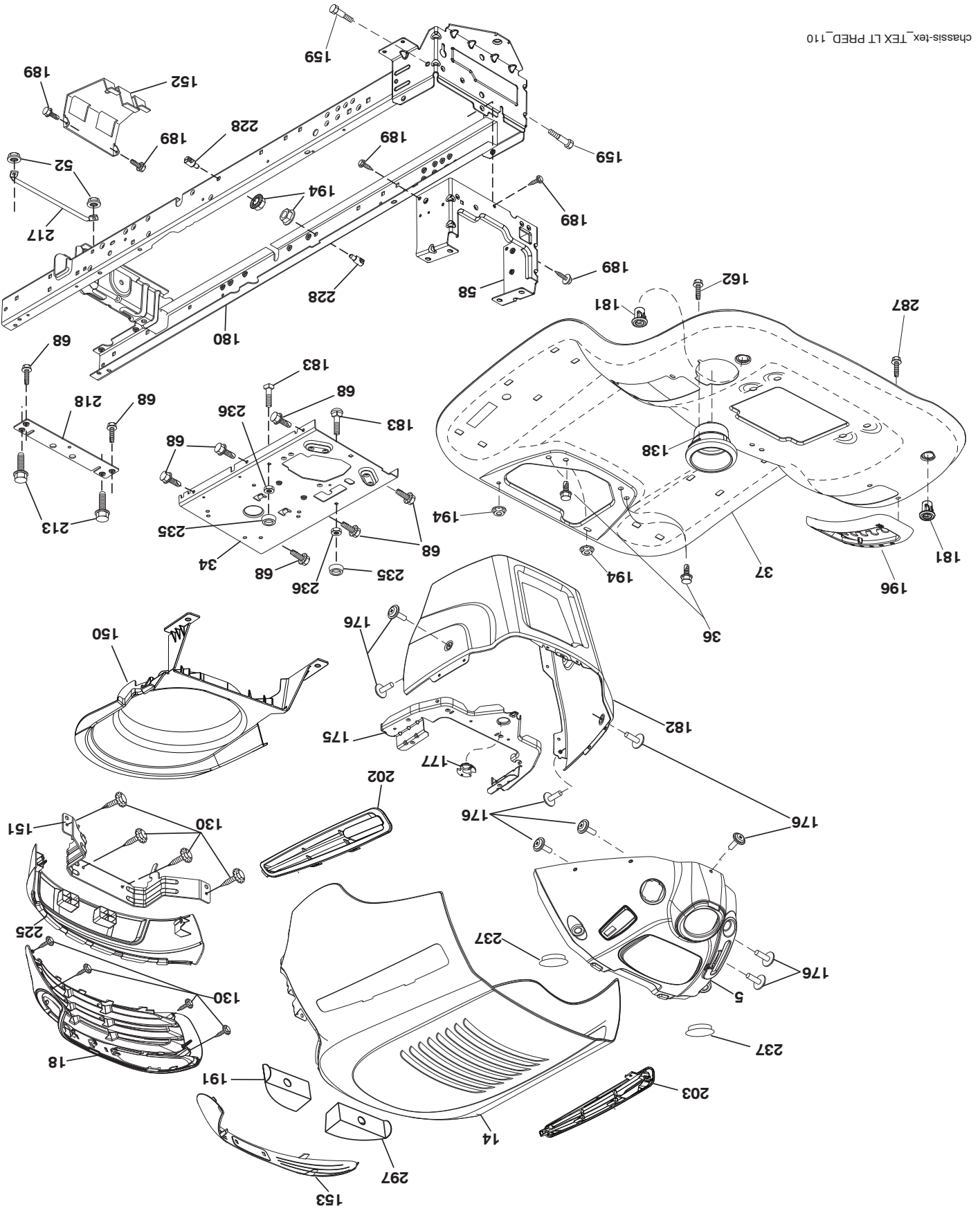

NO.	DE	RÉF.	PIÈCE	DESCRIPTION
1		163465	Batterie	
2		74760412	Boulon 1/4-20 unc x 3/4	
8		193228	Bac de batterie	
16		176138	Interrupteur	
21		400252	Harnais de prise de courant d'ampoule 4152J	
22		4152J	Ampoule	
25		581498001	Cable 6 Ja. 14.5"	
26		175158	Fusible	
27		73510400	Ecrou 1/4-20 unc	
28		421686	Câble	
29		192749	Interrupteur de siège	
30		193350	Interrupteur d'allumage	
33		411934	Cle/Chaîne	
34		110712X	Interrupteur des phares	
--		401098	Harnais (si équipé avec solénoïde avant)	
--		581023101	Harnais (si équipé avec solénoïde arrière)	
43		192507	Solénoïde	
55		17060512	Vis 5/16-18 x 3/4	
--		400449	Harnais (si équipé avec solénoïde avant)	
--		581023001	Harnais (si équipé avec solénoïde arrière)	
79		175242	Prise de courant d'ampoule	
87		197802	Interrupteur de verrouillage de câble d'embrayage	
90		435395	Couvercle du borne de batterie	
99		17670412	Vis	
102		581023401	Harnais de fil	
105		407568	Commutez, renversez	
106		174814	Ecrou	

**REMARQUE:** Toutes les dimensions de composant sont données en pouces E.-U. -- 1 pouce = 25,4 mm

# TRACTEUR - - NUMÉRO DE MODÈLE 944.604180

## ELECTRIQUE

TR02K-f

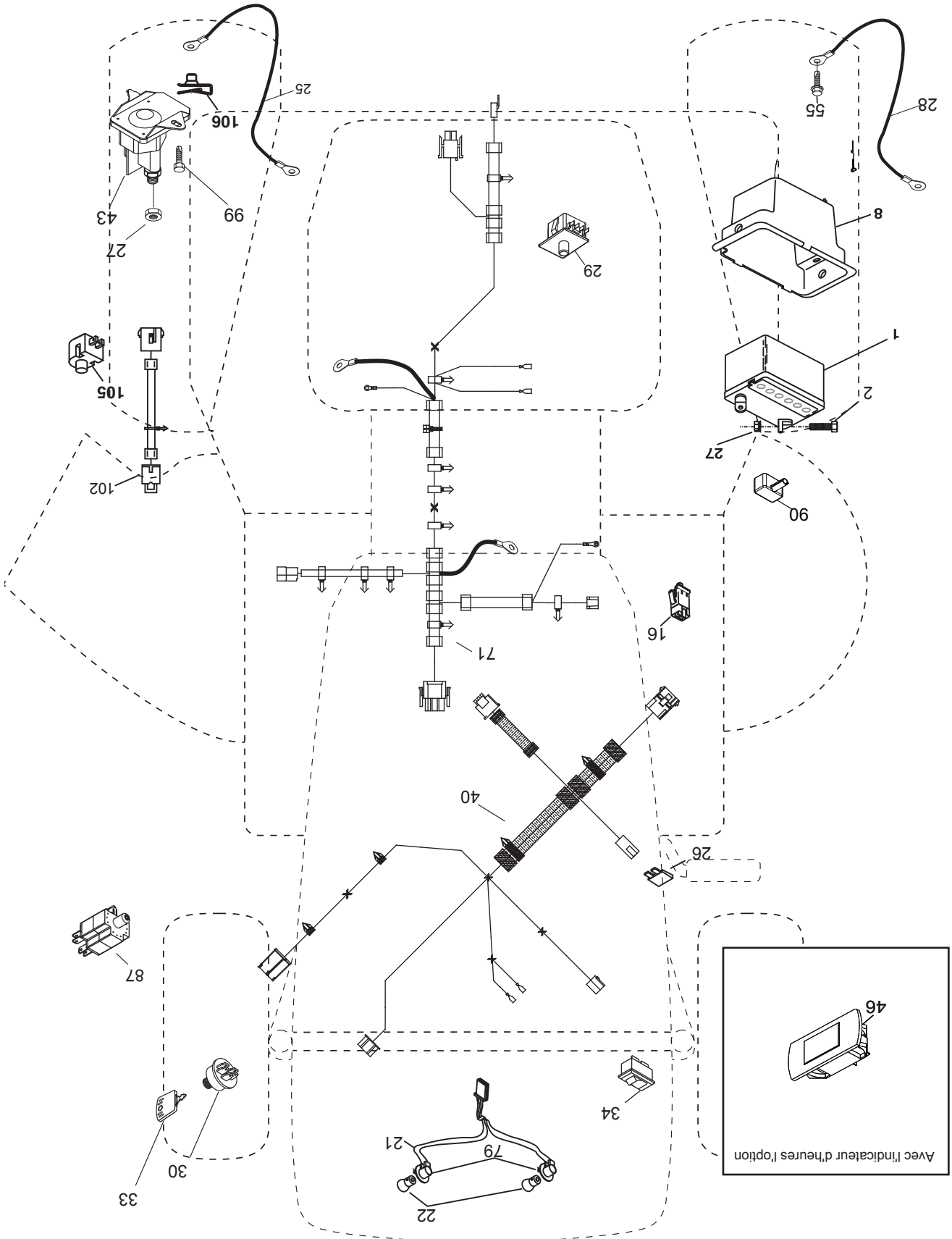
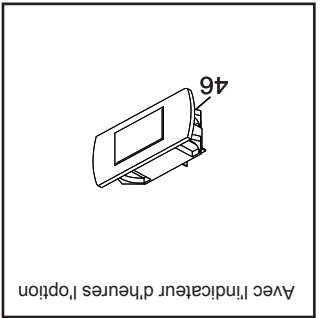

TRACTEUR - - NUMÉRO DE MODÈLE 944.604180

CONTACTEUR D'ALLUMAGE

POSITION	CIRCUIT "FAITS"
ARRÊT	M + G + A1
MARCHE/ ALLUMAGE	B + A1
MARCHE	B + A1
DÉPARTAGE	B + S + A1

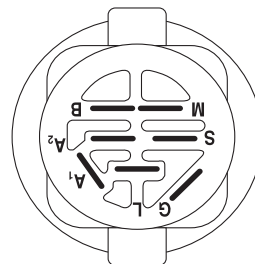

**REMARQUE**  
 VOTRE TRACTEUR EST ÉQUIPÉ D'UN SYSTÈME D'ALTERNATEUR SPÉCIAL AU LIEU D'ÊTRE BRANCHÉS SUR LA BATTERIE. LES PHARES DISPOSENT DE LEUR PROPRE SOURCE D'ÉNERGIE ÉLECTRIQUE. DONC LA BRILLANCE DES PHARES CHANGERA EN FONCTION DE LA VITESSE DU MOTEUR. AU RALENTI, LA BRILLANCE DES PHARES BAISSERA. QUAND LE MOTEUR EST ACCÉLÉRÉ, LA BRILLANCE ATTEINDRA SON MAXIMUM.

NOIR

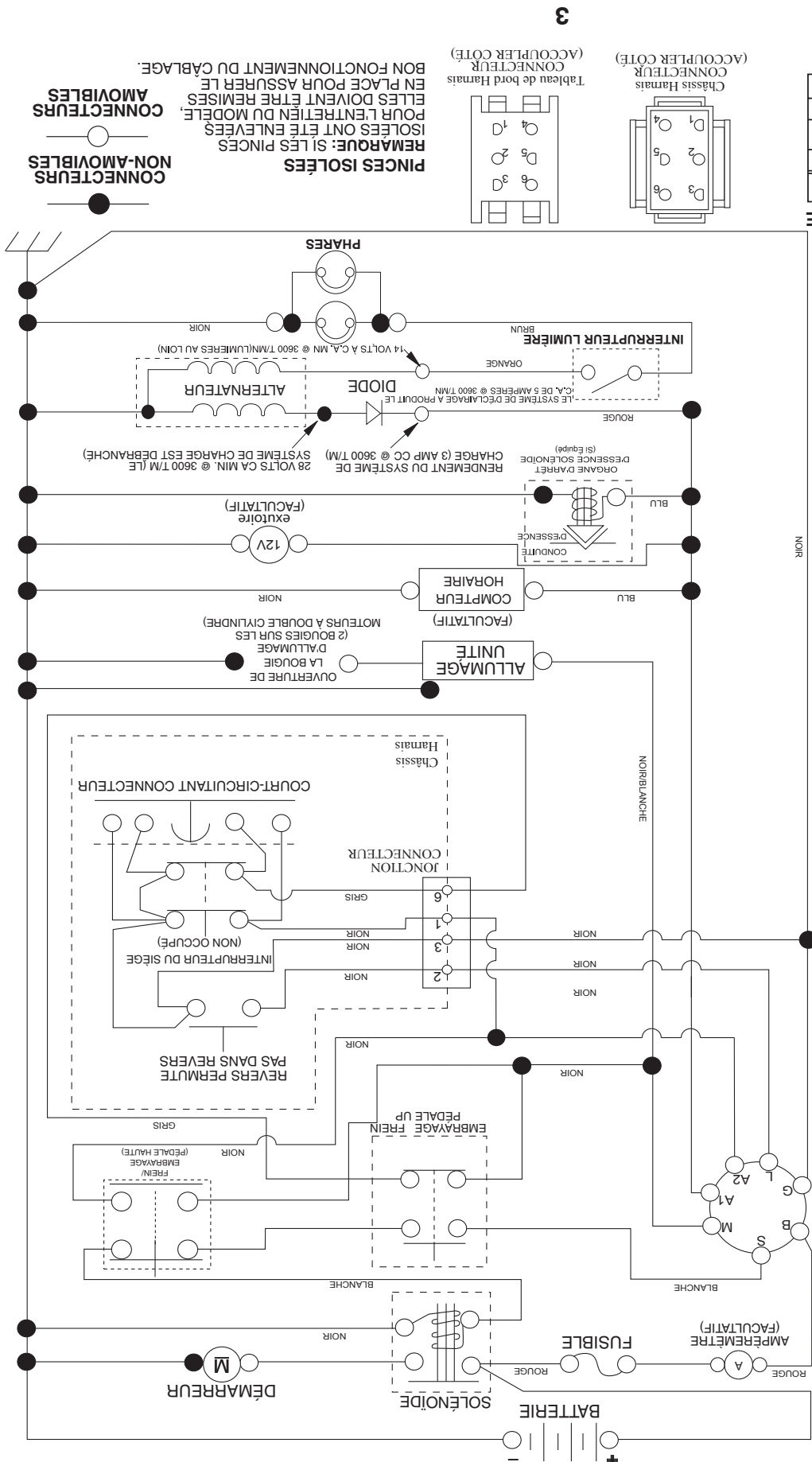

3

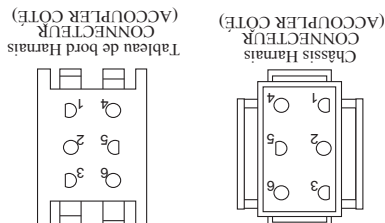

**PINCES ISOLÉES**  
 REMARQUE: SI LES PINCES ISOLÉES ONT ÉTÉ ENLEVÉES POUR L'ENTRETIEN DU MODÈLE, ELLES DOIVENT ÊTRE REMISES EN PLACE POUR ASSURER LE BON FONCTIONNEMENT DU CÂBLAGE.

**CONNECTEURS AMOVIBLES**  
**CONNECTEURS NON-AMOVIBLES**

# COMMENT UTILISER CE MANUEL

Ce manuel a été dessiné pour fournir le client avec les moyens d'identification des pièces de détails du tracteur quand il/elle a besoin de commander les pièces de rechange. Les illustrations ne peuvent pas représenter exactement le modèle que vous avez acheté. N'utilisez pas ce manuel comme un guide dans le montage et/ou démontage de votre tracteur. La visserie montrée est plus grande pour faciliter l'identification.

Chaque tracteur a un numéro de modèle particulier.

Le numéro de modèle du produit se trouvera sur l'aile, dessous le siège.

Lorsque vous commandez des pièces de rechange, donnez toujours les renseignements suivants:

- Produit - "TRACTEUR"
- NUMÉRO DU MODÈLE - "944.604180"
- Numéro de la Pièce
- Description de la Pièce

## TABLE DE MATIERES

SCHEMA.....	3
ELECTRIQUE.....	4-5
CHASSIS/ENCEINTES.....	6-7
ENTRAÎNEMENT.....	8-9
MOTEUR.....	10-11
ENSEMBLE DE LA DIRECTION.....	12-13
CARTER DE TONDEUSE.....	14-15
LEVAGE DE LA TONDEUSE.....	16
ENSEMBLE DU SIÈGE.....	17
DECALCOMANIES.....	18
VOYEZ LES DÉTAILS DE MOTOR.....	19-22
ENTRETIEN DE "SEARS".....	24

Sears Canada, Inc., Toronto, Ontario M5B 2B8

\* La puissance nominale indiquée par le fabricant du moteur est la puissance brute moyenne (à un régime en tr/min spécifique) d'un moteur de production type pour le modèle de moteur mesuré selon les normes SAE pour la puissance brute du moteur. Se reporter au fabricant du moteur pour tous les détails.

**18,5 C.V.\***  
**DÉMARRAGE ÉLECTRIQUE**  
**TONDEUSE DE 107 CM (42 PO.)**  
**AUTOMATIQUE**  
**TRACTEUR DE PELOUSE**

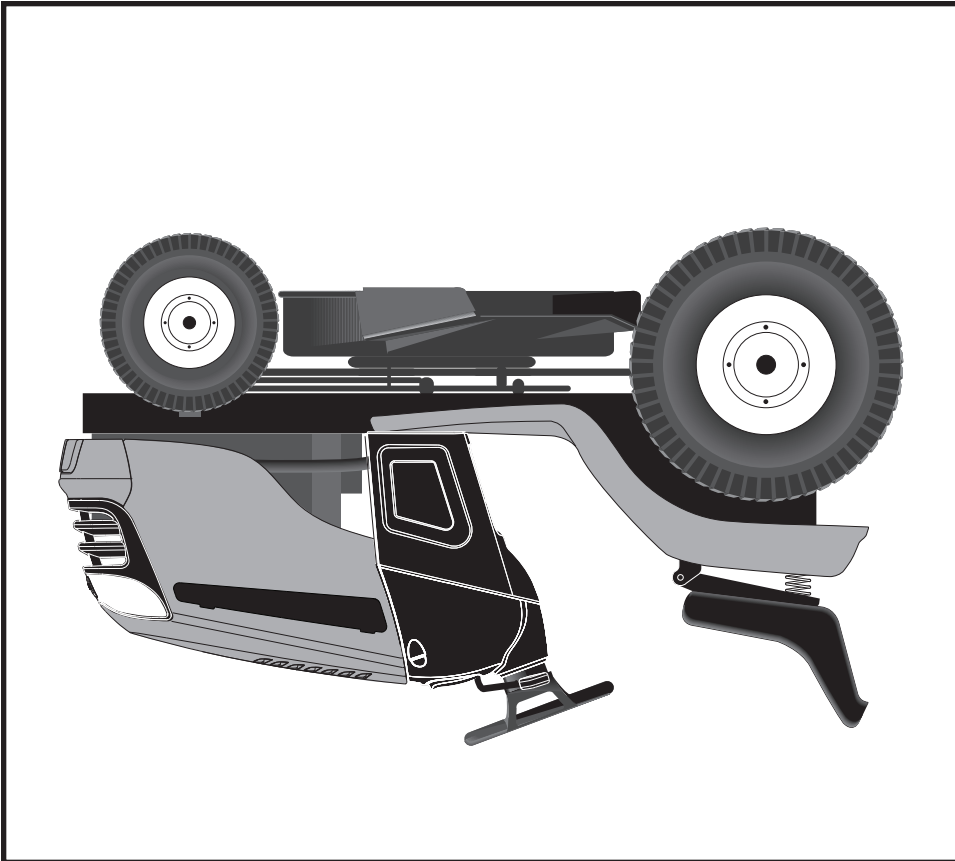

**IMPORTANT:**  
Lisez et suivez le mode d'emploi et toutes les règles de sécurité avant d'utiliser cet équipement

**NUMÉRO DE MODÈLE**  
**944.604180**

**SEARS**  
**MANUEL DES PIÈCES DE RECHANGE**