

DO NOT MAIL!

REV 1 3/4/94

SEARS

For Copying Only

Change # p. 41

CRAFTSMAN®

MODEL NUMBER 917.257720 OWNER'S MANUAL

3.5

- Assembly
- Operation
- Customer Responsibilities
- Service and Adjustments
- Repair Parts

same as a 944.604380

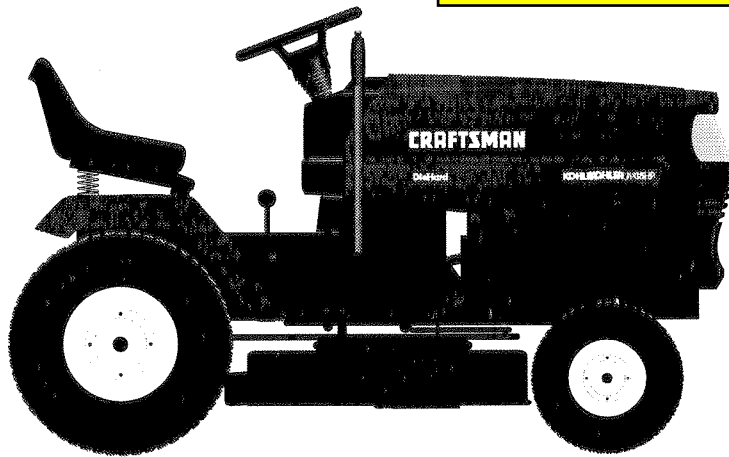

CAUTION: Read and follow all safety rules and instructions before operating this equipment.

Sears, Roebuck and Co., Hoffman Estates, IL 60179 U.S.A.



SAFETY RULES

Safe Operation Practices for Ride-On Mowers



IMPORTANT: THIS CUTTING MACHINE IS CAPABLE OF AMPUTATING HANDS AND FEET AND THROWING OBJECTS. FAILURE TO OBSERVE THE FOLLOWING SAFETY INSTRUCTIONS COULD RESULT IN SERIOUS INJURY OR DEATH.

I. GENERAL OPERATION

- Read, understand, and follow all instructions in the manual and on the machine before starting.
- Only allow responsible adults, who are familiar with the instructions, to operate the machine.
- Clear the area of objects such as rocks, toys, wire, etc., which could be picked up and thrown by the blade.
- Be sure the area is clear of other people before mowing. Stop machine if anyone enters the area.
- Never carry passengers.
- Do not mow in reverse unless absolutely necessary. Always look down and behind before and while backing.
- Be aware of the mower discharge direction and do not point it at anyone. Do not operate the mower without either the entire grass catcher or the guard in place.
- Slow down before turning.
- Never leave a running machine unattended. Always turn off blades, set parking brake, stop engine, and remove keys before dismounting.
- Turn off blades when not mowing.
- Stop engine before removing grass catcher or unclogging chute.
- Mow only in daylight or good artificial light.
- Do not operate the machine while under the influence of alcohol or drugs.
- Watch for traffic when operating near or crossing roadways.
- Use extra care when loading or unloading the machine into a trailer or truck.

II. SLOPE OPERATION

Slopes are a major factor related to loss-of-control and tipover accidents, which can result in severe injury or death. All slopes require extra caution. If you cannot back up the slope or if you feel uneasy on it, do not mow it.

DO:

- Mow up and down slopes, not across.
- Remove obstacles such as rocks, tree limbs, etc.
- Watch for holes, ruts, or bumps. Uneven terrain could overturn the machine. *Tall grass can hide obstacles.*
- Use slow speed. Choose a low gear so that you will not have to stop or shift while on the slope.
- Follow the manufacturer's recommendations for wheel weights or counterweights to improve stability.
- Use extra care with grass catchers or other attachments. These can change the stability of the machine.
- Keep all movement on the slopes *slow* and *gradual*. Do not make sudden changes in speed or direction.
- Avoid starting or stopping on a slope. If tires lose traction, disengage the blades and proceed slowly *straight* down the slope.

DO NOT:

- *Do not* turn on slopes unless necessary, and then, turn slowly and gradually downhill, if possible.
- *Do not* mow near drop-offs, ditches, or embankments. The mower could suddenly turn over if a wheel is over the edge of a cliff or ditch, or if an edge caves in.
- *Do not* mow on wet grass. Reduced traction could cause sliding.
- *Do not* try to stabilize the machine by putting your foot on the ground.
- *Do not* use grass catcher on steep slopes.

III. CHILDREN

Tragic accidents can occur if the operator is not alert to the presence of children. Children are often attracted to the machine and the mowing activity. *Never* assume that children will remain where you last saw them.

- Keep children out of the mowing area and under the watchful care of another responsible adult.
- Be alert and turn machine off if children enter the area.
- Before and when backing, look behind and *down* for small children.
- Never carry children. They may fall off and be seriously injured or interfere with safe machine operation.
- Never allow children to operate the machine.
- Use extra care when approaching blind corners, shrubs, trees, or other objects that may obscure vision.

IV. SERVICE

- Use extra care in handling gasoline and other fuels. They are flammable and vapors are explosive.
 - Use only an approved container.
 - Never remove gas cap or add fuel with the engine running. Allow engine to cool before refueling. Do not smoke.
 - Never refuel the machine indoors.
 - Never store the machine or fuel container inside where there is an open flame, such as a water heater.
- Never run a machine inside a closed area.
- Keep nuts and bolts, especially blade attachment bolts, tight and keep equipment in good condition.
- Never tamper with safety devices. Check their proper operation regularly.
- Keep machine free of grass, leaves, or other debris build-up. Clean oil or fuel spillage. Allow machine to cool before storing.
- Stop and inspect the equipment if you strike an object. Repair, if necessary, before restarting.
- Never make adjustments or repairs with the engine running.
- Grass catcher components are subject to wear, damage, and deterioration, which could expose moving parts or allow objects to be thrown. Frequently check components and replace with manufacturer's recommended parts, when necessary.
- Mower blades are sharp and can cut. Wrap the blade(s) or wear gloves, and use extra caution when servicing them.
- Check brake operation frequently. Adjust and service as required.



Look for this symbol to point out important safety precautions. It means CAUTION!!! BECOME ALERT!!! YOUR SAFETY IS INVOLVED.



CAUTION: Always disconnect spark plug wire and place wire where it cannot contact spark plug in order to prevent accidental starting when setting up, transporting, adjusting or making repairs.

CONGRATULATIONS on your purchase of a Sears Tractor. It has been designed, engineered and manufactured to give you the best possible dependability and performance.

Should you experience any problem you cannot easily remedy, please contact your nearest Sears Authorized Service Center/Department. We have competent, well-trained technicians and the proper tools to service or repair this unit.

Please read and retain this manual. The instructions will enable you to assemble and maintain your unit properly. Always observe the "SAFETY RULES".

MODEL NUMBER	917.257720
SERIAL NUMBER	_____
DATE OF PURCHASE	_____
THE MODEL AND SERIAL NUMBERS WILL BE FOUND ON A PLATE UNDER THE SEAT.	
YOU SHOULD RECORD BOTH SERIAL NUMBER AND DATE OF PURCHASE AND KEEP IN A SAFE PLACE FOR FUTURE REFERENCE.	

PRODUCT SPECIFICATIONS

HORSEPOWER:	18.0															
GASOLINE CAPACITY AND TYPE:	3.5 GALLONS UNLEADED REGULAR															
OIL TYPE (API-SG):	SAE 30 (above 32°F) SAE 5W-30 (below 32°F)															
OIL CAPACITY:	W/ FILTER: 4.0 PINTS W/O FILTER: 3.5 PINTS															
SPARK PLUG: (GAP: .025")	CHAMPION RV17YC															
VALVE CLEARANCE:	INTAKE: .003" - .006" EXHAUST: .016" - .019"															
GROUND SPEED (MPH):	<table border="1"> <tr> <td>Forward</td> <td>LO</td> <td>HI</td> </tr> <tr> <td>1st</td> <td>0.8</td> <td>1.8</td> </tr> <tr> <td>2nd</td> <td>1.4</td> <td>3.4</td> </tr> <tr> <td>3rd</td> <td>2.4</td> <td>5.6</td> </tr> <tr> <td>Reverse</td> <td>0.9</td> <td>2.2</td> </tr> </table>	Forward	LO	HI	1st	0.8	1.8	2nd	1.4	3.4	3rd	2.4	5.6	Reverse	0.9	2.2
Forward	LO	HI														
1st	0.8	1.8														
2nd	1.4	3.4														
3rd	2.4	5.6														
Reverse	0.9	2.2														
TRANSAXLE OIL CAPACITY AND TYPE:	4 QUARTS SAE 30 API-SG															
TIRE PRESSURE:	FRONT: 14 PSI REAR: 10 PSI															
CHARGING SYSTEM:	15 AMPS @ 3600 RPM															
BLADE BOLT TORQUE:	30-35 FT. LBS.															

MAINTENANCE AGREEMENT

A Sears Maintenance Agreement is available on this product. Contact your nearest Sears store for details.

CUSTOMER RESPONSIBILITIES

- Read and observe the safety rules.
- Follow a regular schedule in maintaining, caring for and using your unit.
- Follow the instructions under "Customer Responsibilities" and "Storage" sections of this owner's manual.

WARNING: This unit is equipped with an internal combustion engine and should not be used on or near any unimproved forest-covered, brush-covered or grass-covered land unless the engine's exhaust system is equipped with a spark arrester meeting applicable local or state laws (if any). If a spark arrester is used, it should be maintained in effective working order by the operator.

In the state of California the above is required by law (Section 4442 of the California Public Resources Code). Other states may have similar laws. Federal laws apply on federal lands. A spark arrester for the muffler is available through your nearest Sears Authorized Service Center/Department (See REPAIR PARTS section of this manual).

LIMITED TWO YEAR WARRANTY ON ELECTRIC START RIDING EQUIPMENT

For two (2) years from the date of purchase, if this riding equipment is maintained, lubricated and tuned up according to the instructions in the owner's manual, Sears will repair or replace, free of charge, any parts found to be defective in material or workmanship.

This Warranty does not cover:

- Expendable items which become worn during normal use, such as blades, spark plugs, air cleaners and belts.
- Tire replacement or repair caused by punctures from outside objects, such as nails, thorns, stumps, or glass.
- Repairs necessary because of operator abuse, negligence, improper storage or accident or the failure to maintain the equipment according to the instructions contained in the owner's manual.
- Riding equipment used for commercial or rental purposes.

LIMITED 90 DAY WARRANTY ON BATTERY

For ninety (90) days from date of purchase, if any battery included with this riding equipment proves defective in material or workmanship and our testing determines the battery will not hold a charge, Sears will replace the battery at no charge.

WARRANTY SERVICE IS AVAILABLE BY RETURNING THE RIDING EQUIPMENT TO THE NEAREST SEARS SERVICE CENTER/DEPARTMENT IN THE UNITED STATES.

This Warranty gives you specific legal rights, and you may also have other rights which may vary from state to state.

SEARS, ROEBUCK AND CO., D/817 WA, HOFFMAN ESTATES, ILLINOIS 60179

TABLE OF CONTENTS

<p>SAFETY RULES 2</p> <p>PRODUCT SPECIFICATIONS 3</p> <p>CUSTOMER RESPONSIBILITIES 3, 15-18</p> <p>WARRANTY 3</p> <p>TRACTOR ACCESSORIES 5</p> <p>ASSEMBLY 7-10</p> <p>OPERATION 11-14</p>	<p>MAINTENANCE SCHEDULE 15</p> <p>SERVICE AND ADJUSTMENTS 19-25</p> <p>STORAGE 26</p> <p>TROUBLESHOOTING 28-29</p> <p>REPAIR PARTS - TRACTOR 31-47</p> <p>REPAIR PARTS - ENGINE 48-57</p> <p>PARTS ORDERING/SERVICE BACK COVER</p>
---	---

INDEX

<p>A</p> <p>Accessories 5</p> <p>Adjustments:</p> <p style="padding-left: 20px;">Brake 21</p> <p style="padding-left: 20px;">Carburetor 25</p> <p style="padding-left: 20px;">Clutch Pulley 21</p> <p style="padding-left: 20px;">Gauge Wheels 13</p> <p style="padding-left: 20px;">Mower</p> <p style="padding-left: 40px;">Front-To-Back 20</p> <p style="padding-left: 40px;">Side-To-Side 19</p> <p style="padding-left: 20px;">Throttle Control Cable 25</p> <p>Air Filter, Engine 18</p> <p>Air Screen, Engine 18</p> <p>Assembly 7-10</p> <p>B</p> <p>Battery:</p> <p style="padding-left: 20px;">Charging 8</p> <p style="padding-left: 20px;">Cleaning 16</p> <p style="padding-left: 20px;">Installation 10</p> <p style="padding-left: 20px;">Levels 8, 16</p> <p style="padding-left: 20px;">Preparation 8</p> <p style="padding-left: 20px;">Starting with Weak Battery 21</p> <p style="padding-left: 20px;">Storage 24</p> <p style="padding-left: 20px;">Terminals 17</p> <p>Belt:</p> <p style="padding-left: 20px;">Motion Drive</p> <p style="padding-left: 40px;">Removal/Replacement 22</p> <p style="padding-left: 20px;">Mower Drive</p> <p style="padding-left: 40px;">Removal/Replacement 20</p> <p style="padding-left: 20px;">Mower Blade Drive</p> <p style="padding-left: 40px;">Removal/Replacement 21</p> <p>Blade:</p> <p style="padding-left: 20px;">Sharpening 16</p> <p style="padding-left: 20px;">Replacement 16</p> <p>Brake Adjustment 21</p> <p>C</p> <p>Carburetor Adjustment 25</p> <p>Clutch Pulley 21</p> <p>Controls, Tractor 11</p> <p>Customer Responsibilities 15-18</p> <p>Engine:</p> <p style="padding-left: 20px;">Air Filter 18</p> <p style="padding-left: 20px;">Air Screen 18</p> <p style="padding-left: 20px;">Cooling Fins 18</p> <p style="padding-left: 20px;">Engine Oil 13, 16</p> <p style="padding-left: 20px;">Fuel Filter 18</p> <p style="padding-left: 20px;">Spark Plug(s) 18</p> <p>Tractor:</p> <p style="padding-left: 20px;">Battery 17</p> <p style="padding-left: 20px;">Blade 14</p> <p style="padding-left: 20px;">Lubrication Chart 15</p> <p style="padding-left: 20px;">Maintenance Schedule 15</p> <p style="padding-left: 20px;">Tire Care 8, 15, 21</p> <p style="padding-left: 20px;">Transaxle 16</p> <p>Cutting Height, Mower 12</p>	<p>E</p> <p>Electrical:</p> <p style="padding-left: 20px;">Interlocks and Relays 22</p> <p style="padding-left: 20px;">Schematic 30</p> <p style="padding-left: 20px;">Wiring Diagram 32</p> <p>Engine:</p> <p style="padding-left: 20px;">Air Filter 18</p> <p style="padding-left: 20px;">Air Screen 18</p> <p style="padding-left: 20px;">Cooling Fins 18</p> <p style="padding-left: 20px;">Oil Change 17</p> <p style="padding-left: 20px;">Oil Level 17</p> <p style="padding-left: 20px;">Oil Type 13, 17</p> <p style="padding-left: 20px;">Preparation 13</p> <p style="padding-left: 20px;">Repair Parts 48-57</p> <p style="padding-left: 20px;">Starting 13, 14</p> <p style="padding-left: 20px;">Storage 26</p> <p>F</p> <p>Filter:</p> <p style="padding-left: 20px;">Air Filter 18</p> <p style="padding-left: 20px;">Fuel 18</p> <p style="padding-left: 20px;">Oil 18</p> <p>Fuel:</p> <p style="padding-left: 20px;">Storage 26</p> <p style="padding-left: 20px;">Type 14</p> <p>Fuse 22</p> <p>H</p> <p>Headlights 24</p> <p>Hood Removal/Installation 24</p> <p>L</p> <p>Leveling Mower Deck 19</p> <p>Lubrication:</p> <p style="padding-left: 20px;">Chart 15</p> <p style="padding-left: 20px;">Engine 16</p> <p>M</p> <p>Maintenance Schedule 15</p> <p>Mower:</p> <p style="padding-left: 20px;">Adjustment, Front-to-Back 19</p> <p style="padding-left: 20px;">Adjustment, Side-to-Side 19</p> <p style="padding-left: 20px;">Blade Replacement 16</p> <p style="padding-left: 20px;">Blade Sharpening 16</p> <p style="padding-left: 20px;">Cutting Height 12</p> <p style="padding-left: 20px;">Installation 19</p> <p style="padding-left: 20px;">Operation 13</p> <p style="padding-left: 20px;">Removal 19</p> <p>Mowing Tips 14</p> <p>Muffler 18</p> <p style="padding-left: 20px;">Spark Arrester 3, 38</p> <p>O</p> <p>Oil:</p> <p style="padding-left: 20px;">Cold Weather Conditions 13, 17</p> <p style="padding-left: 20px;">Engine 17</p> <p style="padding-left: 20px;">Storage 26</p>	<p>Operation 11-14</p> <p>Operating Mower 13</p> <p>Options:</p> <p style="padding-left: 20px;">Accessories 5</p> <p style="padding-left: 20px;">Spark Arrester 3, 38</p> <p>P</p> <p>Parking Brake 11-12</p> <p>Parts Bag 6</p> <p>Parts, Replacement/Repair 31-47</p> <p>Product Specifications 3</p> <p>R</p> <p>Repair Parts 31-47</p> <p>S</p> <p>Safety Rules 2</p> <p>Seat 8</p> <p>Service and Adjustments 19-25</p> <p style="padding-left: 20px;">Carburetor 25</p> <p style="padding-left: 20px;">Clutch Pulley 21</p> <p style="padding-left: 20px;">Fuse 23</p> <p style="padding-left: 20px;">Hood Removal/Installation 24</p> <p style="padding-left: 20px;">Motion Drive Belt</p> <p style="padding-left: 40px;">Removal/Replacement 22</p> <p style="padding-left: 20px;">Mower Drive Belt</p> <p style="padding-left: 40px;">Removal/Replacement 20</p> <p style="padding-left: 20px;">Mower Blade Drive Belt</p> <p style="padding-left: 40px;">Removal/Replacement 21</p> <p style="padding-left: 20px;">Mower Adjustment</p> <p style="padding-left: 40px;">Front-to-Back 20</p> <p style="padding-left: 40px;">Side-to-Side 19</p> <p style="padding-left: 20px;">Mower Removal/Installation 18</p> <p style="padding-left: 20px;">Tire Care 8, 15, 21</p> <p>Slope Guide Sheet 59</p> <p>Spark Plug(s) 17</p> <p>Specifications 3</p> <p>Starting the Engine 13-14</p> <p>Steering Wheel 7, 22</p> <p>Stopping the Tractor 12</p> <p>Storage 26</p> <p>T</p> <p>Throttle Control Cable Adjustment 25</p> <p>Tires 8, 15, 21</p> <p>Troubleshooting Chart 28-29</p> <p>Transaxle 16, 46-47</p> <p>W</p> <p>Warranty 3</p> <p>Wiring Diagram 32</p> <p>Wiring Schematic 30</p>
---	--	--

ACCESSORIES AND ATTACHMENTS

These accessories and attachments were available through most Sears retail outlets and service centers when the tractor was purchased. Most Sears stores can order these items for you when you provide the model number of your tractor.

ENGINE

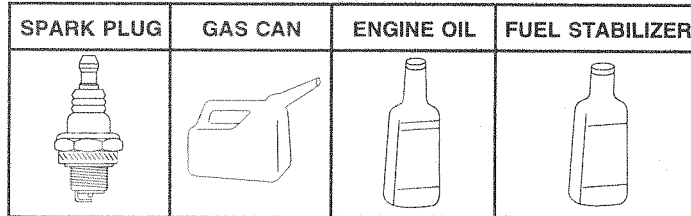

MAINTENANCE

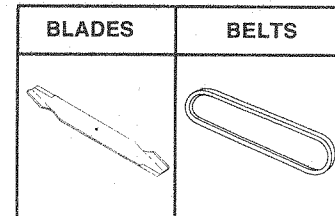

PERFORMANCE

Sears offers a wide variety of attachments that fit your tractor. Many of these are listed below with brief explanations of how they can help you. This list was current at the time of publication; however, it may change in future years - more attachments may be added, changes may be made in these attachments, or some may no longer be available or fit your model. **Contact your nearest Sears store for the accessories and attachments that are available for your tractor.**

Most of these attachments do not require additional hitches or conversion kits (those that do are indicated) and are designed for easy attaching and detaching.

AERATOR promotes deep root growth for a healthy lawn. Tapered 2.5-inch steel spikes mounted on 10-inch diameter discs puncture holes in soil at close intervals to let moisture soak in. Steel weight tray for increased penetration.

BUMPER protects front end of tractor from damage.

CARTS make hauling easy. Variety of sizes available, plus accessories such as side panel kits, tool caddy, cart cover, protective mat and dolly.

CORING AERATOR takes small plugs out of soil to allow moisture and nutrients to reach grass roots. 36-inch swath. 24 hardened steel coring tips. 150 lb. capacity weight tray.

DISC HARROW has 2 gangs of 4 steel blades that angle from 10 to 20 degrees, 40 inches wide. Can hook 2 units in tandem. (Requires sleeve hitch.)

DOZER BLADE removes snow; grades dirt, sand and gravel. 48 inches wide, 17 inches high, clears 44-inch path when angled. Master lift control lever for operator ease. Spring trip for snow removal on uneven pavement; built-in float for blade to follow ground contour. Reversible, replaceable scraper bar. (Use with tire chains and wheel weights and/or rear drawbar weight.)

EASY OIL DRAIN VALVE makes oil changes easier, faster.

FRONT NOSE ROLLER canters in front of mower deck to reduce chances of "scalping" on uneven terrain.

GANG HITCH lets you tow 2 or 3 pull-behind attachments at once, such as sweepers, dethatchers, aerators (not for use with rollers, carts or other heavy attachments).

MULCH RAKE/DETHATCHER loosens soil and flips thatch and matted leaves to lawn surface for easy pickup. Twenty spring tine teeth. Useful to prepare bare areas for seeding. Available for front or rear mounting. **HIGH PERFORMANCE REEL-ACTION SPRING TINE DETHATCHER** covers 36-inch wide path and tosses thatch into large hopper. Mounts behind tractor.

PLOW turns soil 6 inches deep, cuts 10-inch furrow. Crank adjustment controls depth, 3-position yoke sets width. Heavy steel landside for straight furrowing. (Requires sleeve hitch.)

RAMP TOPS AND FEET let you load and unload tractor from a pickup truck. Use with 2 x 8 or 2 x 10 lumber.

REAR GRADER BLADE is 42 inches wide and operated from driver's seat. Reversible steel blade can be angled at 30 degrees for grading. Reverses for pushing snow backwards. (Requires sleeve hitch.)

ROLLER for smoother lawn surface. 36-inch wide, 18-inch diameter water-tight drum holds up to 390 lbs. of weight. Rounded edges prevent harm to turf. Adjustable scraper automatically cleans drum.

SLEEVE CULTIVATOR is 43 inches wide. Prepares ground for seeding, helps weed control. Steel frame holds 5 adjustable sweeps. Adjusts vertically, horizontally. (Requires sleeve hitch.) **Optional accessory:** steel furrow opener for wider openings for potatoes, corn, and other deep-seeded crops.

SLEEVE HITCH for use with master lift system. Single pin couples/uncouples.

SNOWTHROWER has 42-inch swath. Drum-type auger handles powdery and wet/heavy snow. Mounts easily with simple pin arrangement. Discharge chute adjusts from tractor seat. 6-inch diameter spout discharges snow 10 to 50 feet. Lift controlled at tractor seat. (Use with chains and wheel weights and/or rear drawbar weight.)

SPRAYERS use 12-volt DC electric motor that connects to the tractor battery or other 12-volt source. Includes booms for automatic spraying and hand held wand for spot spraying. Wand has adjustable spray pattern. For applying herbicides, insecticides, fungicides and liquid fertilizers.

SPREADER/SEEDERS make seeding, fertilizing, and weed killing easy. Broadcast spreaders are also useful for granular de-icers and sand.

SWEEPERS let you collect grass clippings and leaves.

TILLER has 8 hp engine to prepare seed beds, cultivate, and compost garden residue. Chain-drive transmission. Six 11-inch diameter one piece heat-treated steel tines. Tills 30-inch path. (Requires sleeve hitch.) Or use 5 hp tow-behind **TILLER** with 36-inch swath to prepare seed beds, cultivate and compost garden residue. Tiller has its own built-in lift and depth control system and does NOT require a sleeve hitch. Fits any lawn, yard or garden tractor. Simply hook up to the tractor drawbar and go! **Optional accessories** for 5 hp tiller convert unit for dethatching, aerating, hilling...without tools.

TIRE CHAINS are heavy duty; closely spaced extra-large cross links give smooth ride, outstanding traction.

TRACTOR CAB has heavy duty vinyl fabric over tubular steel frame, ABS plastic top; clear plastic windshield offers 360 degree visibility. Hinged metal doors with catch. Keeps operator warm and dry. Remove vinyl sides and windshields for use as sun protector in summer. **Optional accessories include:** tinted/tempered solid safety glass windshield with hand operated wiper; 12-volt amber caution light for mounting on cab top.

VACS for powerful collection of heavy grass clippings and leaves. **Optional wand attachment** to pick up debris in hard-to-reach places. **VAC/CHIPPER** includes a chipper-shredder.

WEIGHT BRACKET for drawbar for snow removal applications. Can be mounted on front of tractor for plowing applications. Uses (1) 55 lb. weight.

WHEEL WEIGHTS for rear wheels provide needed traction for snow removal or dozing heavy materials.

CONTENTS OF HARDWARE PACK

Parts Bag contents shown full size

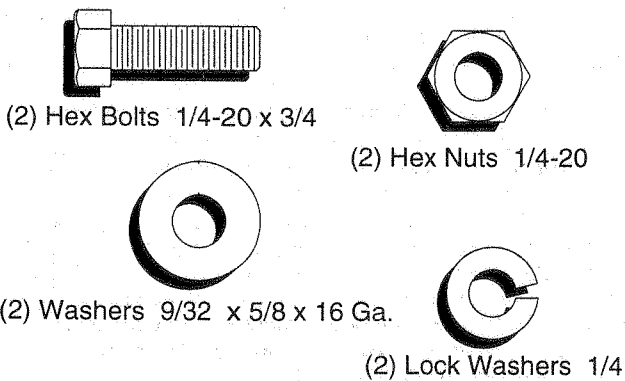
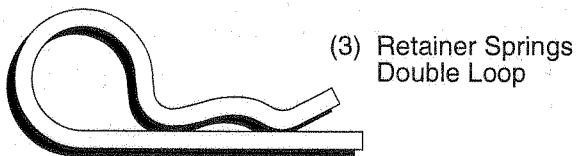
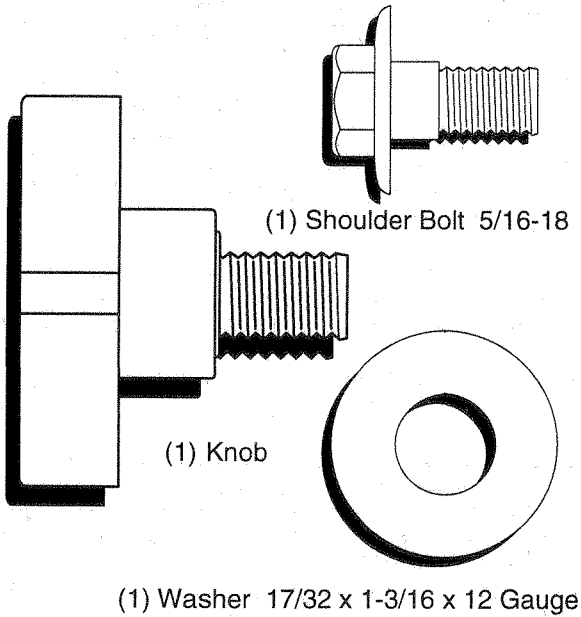

Parts packed separately in carton

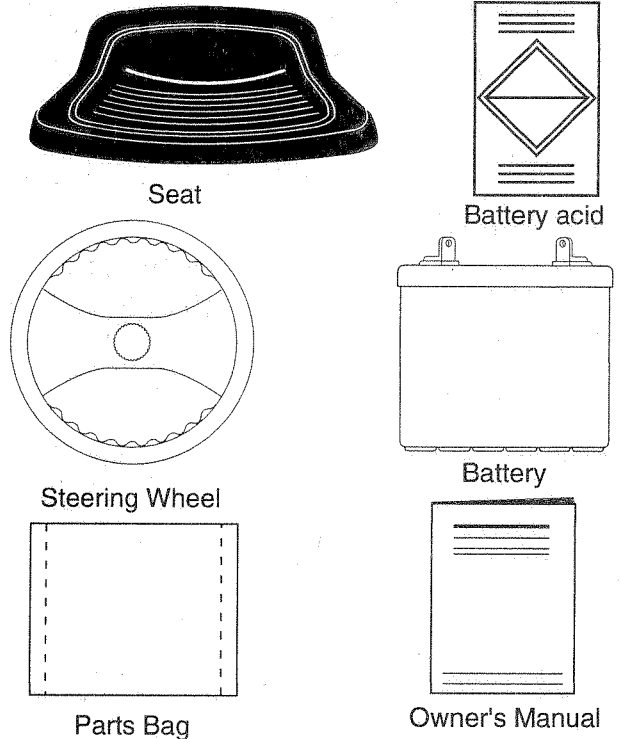

Parts bag contents not shown full size

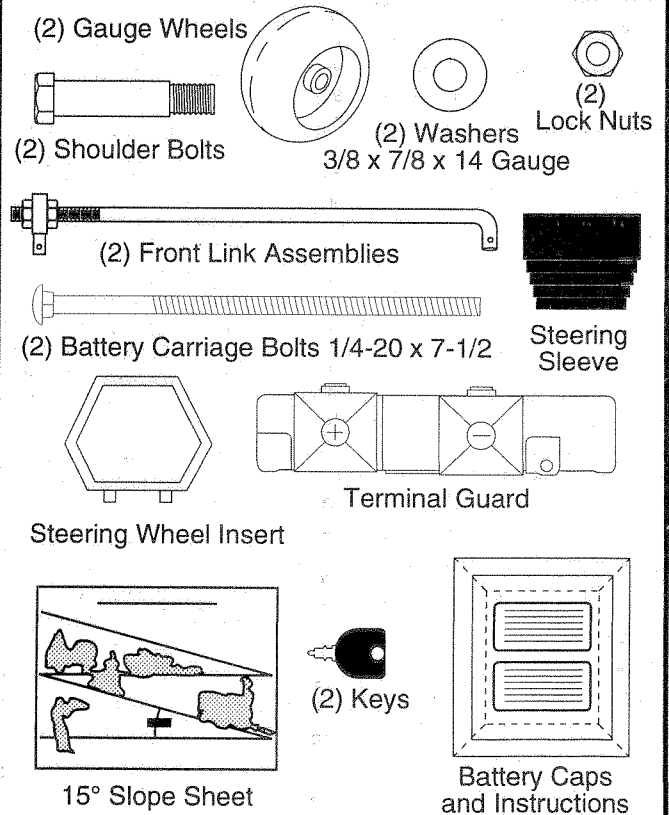

ASSEMBLY

Your new tractor has been assembled at the factory with the exception of those parts left unassembled for shipping purposes. To ensure safe and proper operation of your tractor all parts and hardware you assemble must be tightened securely. Use the correct tools as necessary to insure proper tightness.

TOOLS REQUIRED FOR ASSEMBLY

A socket wrench set will make assembly easier. Standard wrench sizes are listed.

- | | |
|------------------------------------|---------------------|
| (2) 7/16" wrenches | Tire pressure gauge |
| (1) 1/2" wrench | Utility knife |
| (1) 9/16" wrench | |
| (1) 3/4" socket with drive ratchet | |

When right or left hand is mentioned in this manual, it means when you are in the operating position (seated behind the steering wheel).

TO REMOVE TRACTOR FROM CARTON

UNPACK CARTON

- Remove all accessible loose parts and parts cartons from carton (See page 6).
- Cut, from top to bottom, along lines on all four corners of carton, and lay panels flat.
- Remove mower and packing materials.
- Check for any additional loose parts or cartons and remove.

BEFORE ROLLING TRACTOR OFF SKID

ATTACH STEERING WHEEL (See Fig. 1)

- Remove hex bolt, lock washer and large flat washer from steering shaft.
- Position front wheels of the tractor so they are pointing straight forward.
- Slide steering sleeve over steering shaft.
- Position steering wheel so cross bars are horizontal (left to right) and slide onto steering wheel adapter.
- Secure steering wheel to steering shaft with hex bolt, lock washer and large flat washer previously removed. Tighten securely.
- Snap steering wheel insert into center of steering wheel.
- Remove protective plastic from tractor hood and grill.

IMPORTANT: CHECK FOR AND REMOVE ANY STAPLES IN SKID THAT MAY PUNCTURE TIRES WHERE TRACTOR IS TO ROLL OFF SKID.

TO ROLL TRACTOR OFF SKID (See Fig. 7)

- Raise attachment lift lever to its highest position.
- Release parking brake by depressing clutch/brake pedal.
- Place gearshift lever in neutral (N) position.
- Roll tractor backwards off skid.

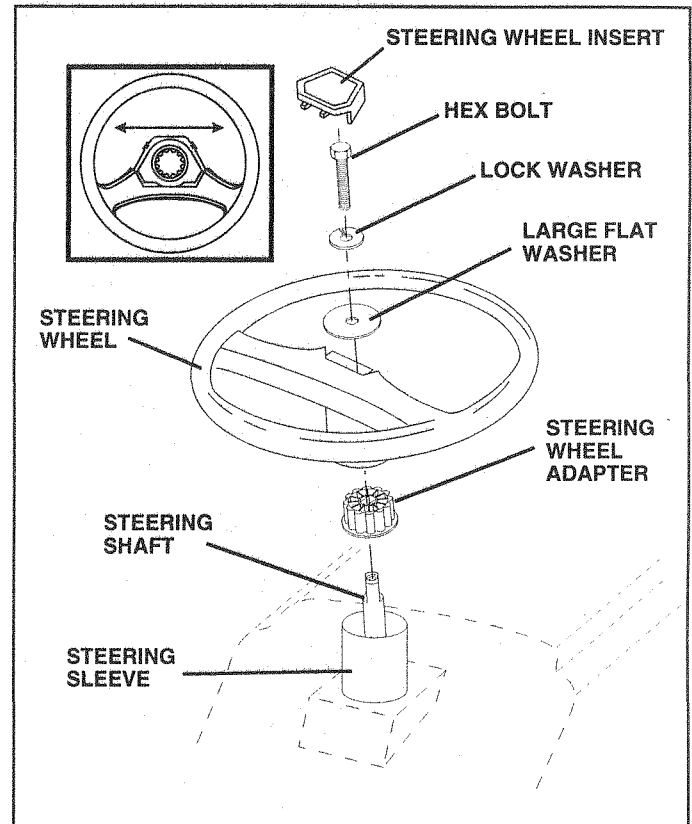

FIG. 1

ASSEMBLY

HOW TO SET UP YOUR TRACTOR

PREPARE BATTERY (See Fig. 2)



CAUTION: Wear eye and face shield.

Wash hands or clothing immediately if accidentally in contact with battery acid.

Do not smoke. Fumes from charged battery acid are explosive.

Read the instructions included with the battery vent caps. Always wear gloves, clothing and goggles to protect your hands, skin and eyes.

Your tractor has a battery charging system which is sufficient for normal use. However, periodic charging of the battery with an automotive charger will extend its life.

- See instructions packed with vent caps in parts bag.
- Fill battery with acid. Fill each cell until it reaches the bottom of the vent wells. Do not overfill.
- Allow battery to stand and settle for at least thirty minutes. After standing, check the battery cell acid level. If below the vent wells, add more acid until the correct level is reached.

While battery is standing (after adding acid) and later, while battery is being charged, continue with assembly of unit.

IMPORTANT: TO MAXIMIZE THE LIFE OF YOUR BATTERY, IT IS NECESSARY THAT THE BATTERY BE CHARGED BEFORE USE. FAILURE TO CHARGE BATTERY CAN RESULT IN A SHORTENED BATTERY LIFE.

- Charge battery at a rate of 6 amperes for 1 hour. Use a 12 volt battery charger. Observe all safety precautions required for battery charging.
- Check the acid level after the battery is charged. If the acid has fallen below the correct level, add distilled or iron free water.
- Install the vent caps to cover the vent wells. Wash the top of the battery with water to remove any acid, then wipe dry.
- Check battery case for leakage to make sure that no damage has occurred in handling.
- Dispose of excess battery acid. Neutralize acid for disposal by adding it to two gallons of water in a five gallon plastic container. Stir with a wooden or plastic paddle while adding baking soda until the addition of more soda causes no more foaming.
- Follow instructions on how to install battery.

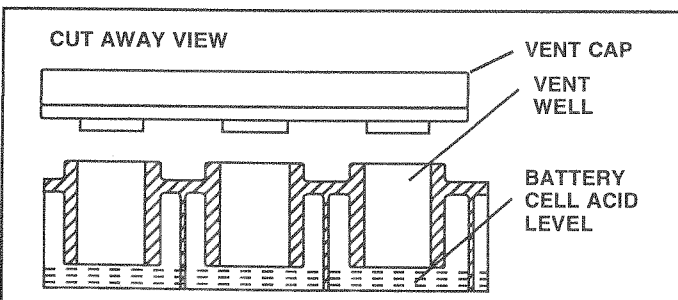

FIG. 2

INSTALL SEAT (See Fig. 3)

Adjust seat before tightening adjustment knob.

- Remove cardboard packing on seat pan.
- Place seat on seat pan and assemble shoulder bolt.
- Assemble adjustment knob and flat washer loosely. Do not tighten.
- Tighten shoulder bolt securely.
- Lower seat into operating position and sit on seat.
- Slide seat until a comfortable position is reached which allows you to press clutch/brake pedal all the way down.
- Get off seat without moving its adjusted position.
- Raise seat and tighten adjustment knob securely.

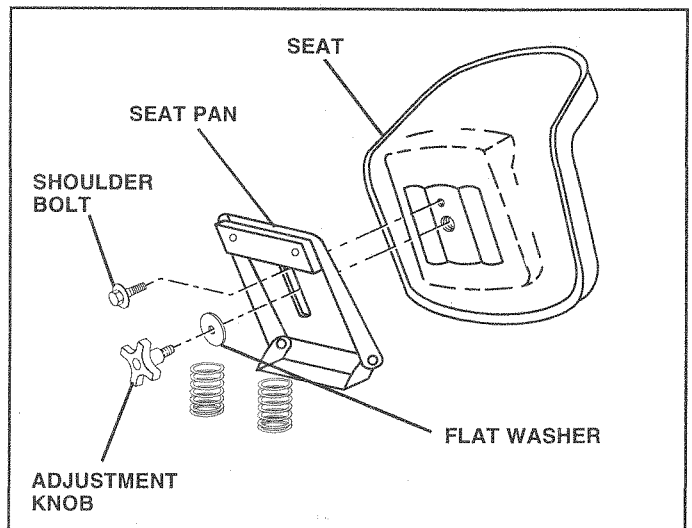

FIG. 3

CHECK TIRE PRESSURE

The tires on your tractor were overinflated at the factory for shipping purposes. Correct tire pressure is important for best cutting performance.

- Reduce tire pressure to PSI shown in "PRODUCT SPECIFICATIONS" on page 3 of this manual.

CHECK BRAKE SYSTEM

After you learn how to operate your tractor, check to see that the brake is properly adjusted. See "TO ADJUST BRAKE" in the Service and Adjustments section of this manual.

ASSEMBLY

INSTALL MOWER AND DRIVE BELT (See Figs. 4 and 7)

Be sure tractor is on level surface. Engage parking brake.

- Cut and remove tie down securing anti-sway bar. Swing anti-sway bar to left side of mower deck.
- Relieve idler tension from belt. Push idler forward and place a block (standard wood 2 x 4 or equivalent) behind idler pulley.
- Slide mower under tractor with discharge guard to right side of tractor.
- Swing L.H. gauge wheel bar forward by removing rear retainer spring and pin.
- Install one front link in top hole of the L.H. front mower bracket and L.H. front suspension bracket. Retain with two single loop retainer springs as shown.
- Slide right side of mower deck forward, toward R.H. front tire.

IMPORTANT: CHECK BELT FOR PROPER ROUTING IN ALL MOWER PULLEY GROOVES. INSTALL BELT INTO ELECTRIC CLUTCH PULLEY GROOVE.

- Install second front link in the top hole of the R.H. front mower bracket and R.H. front suspension bracket. Retain with two single loop retainer springs as shown.
- Carefully remove block from behind idler pulley.
- Turn height adjustment knob counterclockwise until it stops.
- Lower mower linkage with attachment lift lever.

- Place the suspension arms on inward pointing deck pins. If necessary, rock and raise front of mower to align deck pins with the holes in suspension arms. Retain with double loop retainer springs.
- Connect anti-sway bar to chassis bracket under left footrest and retain with double loop retainer spring.
- Turn height adjustment knob clockwise to remove slack from mower suspension.
- Raise deck to highest position.
- Swing L.H. gauge wheel bar back towards rear of mower and secure with pin and retainer spring removed earlier.
- Assemble gauge wheels as shown using long shoulder bolts, 3/8 washers and nuts. Tighten securely.
- Adjust gauge wheels before operating mower as shown in the Operation section of this manual.

CHECK DECK LEVELNESS

For best cutting results, mower housing should be properly leveled. See "TO LEVEL MOWER HOUSING" in the Service and Adjustments section of this manual.

CHECK FOR PROPER POSITION OF ALL BELTS

See the figures that are shown for replacing motion, mower drive, and mower blade drive belts in the Service and Adjustments section of this manual. Verify that the belts are routed correctly.

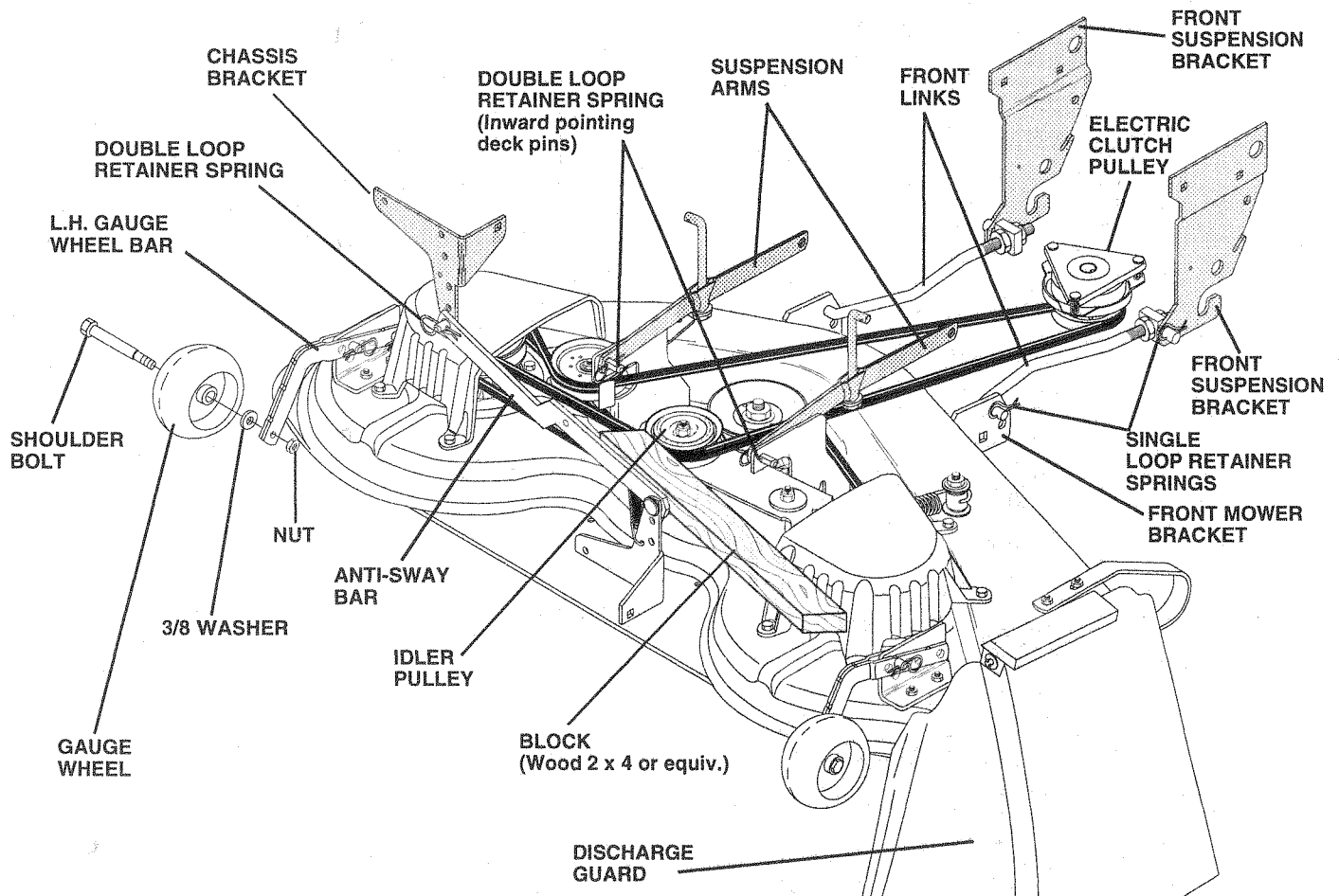

FIG. 4

ASSEMBLY

INSTALL BATTERY (See Figs. 5 and 6)



CAUTION: Do not short battery terminals. Before installing battery, remove metal bracelets, wristwatch bands, rings, etc.

Positive terminal must be connected first to prevent sparking from accidental grounding.

- Lift hood to raised position.
- Be sure battery drain tube has not come loose and is securely attached to drain in battery tray.
- Lower battery into battery tray with terminals to front of tractor.
- First connect RED battery cable to positive (+) battery terminal with hex bolt, flat washer, lock washer and hex nut as shown. Tighten securely.
- Connect BLACK grounding cable to negative (-) battery terminal with remaining hex bolt, flat washer, lock washer and hex nut. Tighten securely.
- Slide the two battery bolts through the terminal guard and start the wing nuts onto the threads.
- Position terminal guard over battery as shown; lower battery bolts into key holes and slide square shafts of battery bolts into slots of key holes.
- Tighten wing nuts by hand making sure battery bolts remain in slots of the key holes in the battery support.
- Be sure terminal access doors are closed.

Use terminal access doors for:

- Inspection for secure connections (to tighten hardware).
- Inspection for corrosion.
- Testing battery.
- Jumping (if required).
- Periodic charging.

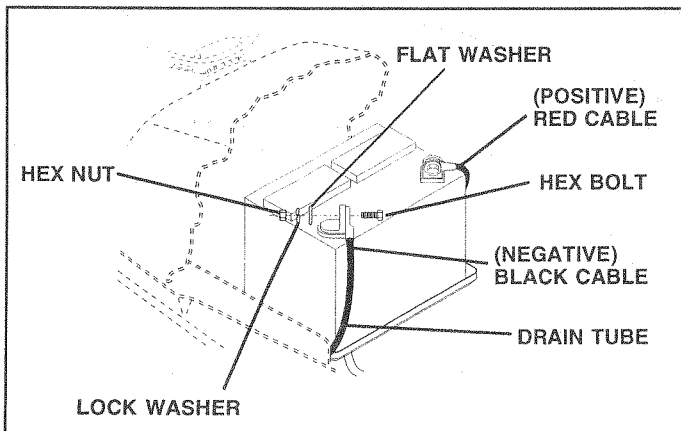

FIG. 5

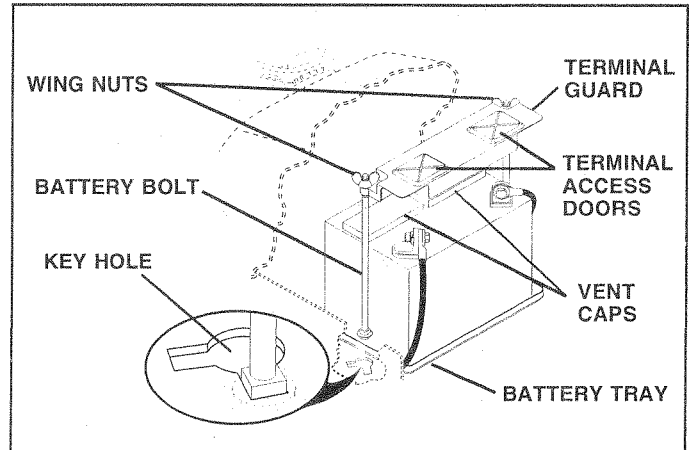

FIG. 6

✓ CHECKLIST

BEFORE YOU OPERATE AND ENJOY YOUR NEW TRACTOR, WE WISH TO ASSURE THAT YOU RECEIVE THE BEST PERFORMANCE AND SATISFACTION FROM THIS QUALITY PRODUCT.

PLEASE REVIEW THE FOLLOWING CHECKLIST:

- ✓ All assembly instructions have been completed.
- ✓ No remaining loose parts in carton.
- ✓ Battery is properly prepared and charged. (Minimum 1 hour at 6 amps).
- ✓ Seat is adjusted comfortably and tightened securely.
- ✓ All tires are properly inflated. (For shipping purposes, the tires were overinflated at the factory).
- ✓ Be sure mower deck is properly leveled side-to-side/front-to-rear for best cutting results. (Tires must be properly inflated for leveling).
- ✓ Check mower and drive belts. Be sure they are routed properly around pulleys and inside all belt keepers.
- ✓ Check wiring. See that all connections are still secure and wires are properly clamped.

WHILE LEARNING HOW TO USE YOUR TRACTOR, PAY EXTRA ATTENTION TO THE FOLLOWING IMPORTANT ITEMS:

- ✓ Engine oil is at proper level.
- ✓ Fuel tank is filled with fresh, clean, regular unleaded gasoline.
- ✓ Become familiar with all controls - their location and function. Operate them before you start the engine.
- ✓ Be sure brake system is in safe operating condition.

OPERATION

KNOW YOUR TRACTOR

READ THIS OWNER'S MANUAL AND SAFETY RULES BEFORE OPERATING YOUR TRACTOR

Compare the illustrations with your tractor to familiarize yourself with the locations of various controls and adjustments. Save this manual for future reference.

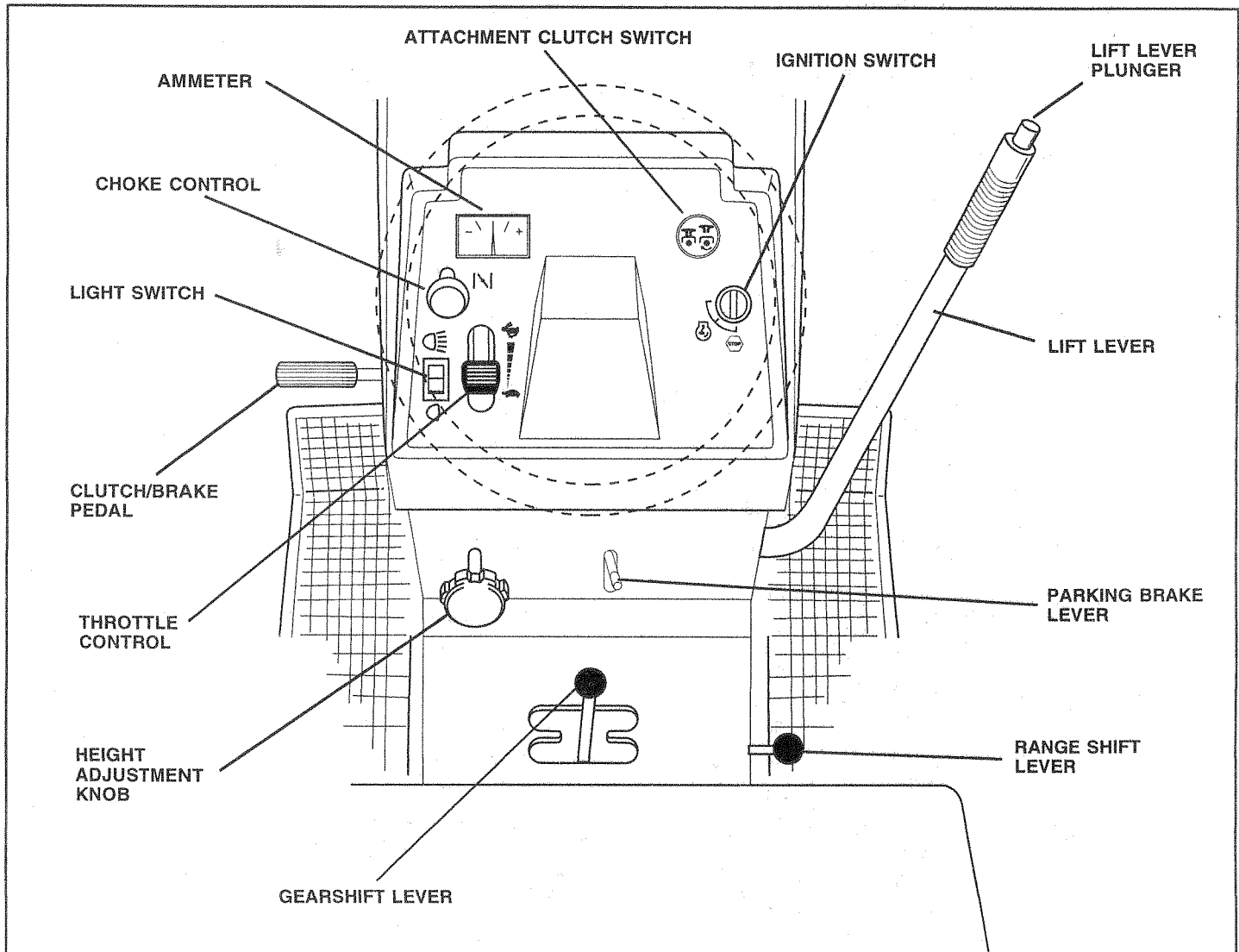

FIG. 7

Our tractors conform to the safety standards of the American National Standards Institute.

ATTACHMENT CLUTCH SWITCH - Used to engage mower blades or other attachments mounted to your tractor.

LIFT LEVER - Used to raise and lower mower deck or other attachments mounted to your tractor.

LIFT LEVER PLUNGER - Used to release attachment lift lever when changing its position.

CLUTCH/BRAKE PEDAL - Used for declutching and braking the tractor and starting the engine.

GEARSHIFT LEVER - Selects the speed and direction of tractor.

THROTTLE CONTROL - Used to control engine speed.

RANGE SHIFT LEVER - Allows high (H) or low (L) speed for all forward and reverse gears.

IGNITION SWITCH - Used to start and stop the engine.

AMMETER - Indicates battery charging (+) or discharging (-).

LIGHT SWITCH - Turns the headlights on and off.

PARKING BRAKE LEVER - Locks clutch/brake pedal into the brake position.

CHOKE CONTROL - Used when starting a cold engine.

HEIGHT ADJUSTMENT KNOB - Used to adjust the mower height.

OPERATION



The operation of any tractor can result in foreign objects thrown into the eyes, which can result in severe eye damage. Always wear safety glasses or eye shields while operating your tractor or performing any adjustments or repairs. We recommend a wide vision safety mask for over the spectacles or standard safety glasses.

HOW TO USE YOUR TRACTOR

TO SET PARKING BRAKE (See Fig. 8)

- Depress clutch/brake pedal into full "BRAKE" position and hold.
- Place parking brake lever in "ENGAGED" position and release pressure from clutch/brake pedal. Pedal should remain in "BRAKE" position. Make sure parking brake will hold vehicle secure.

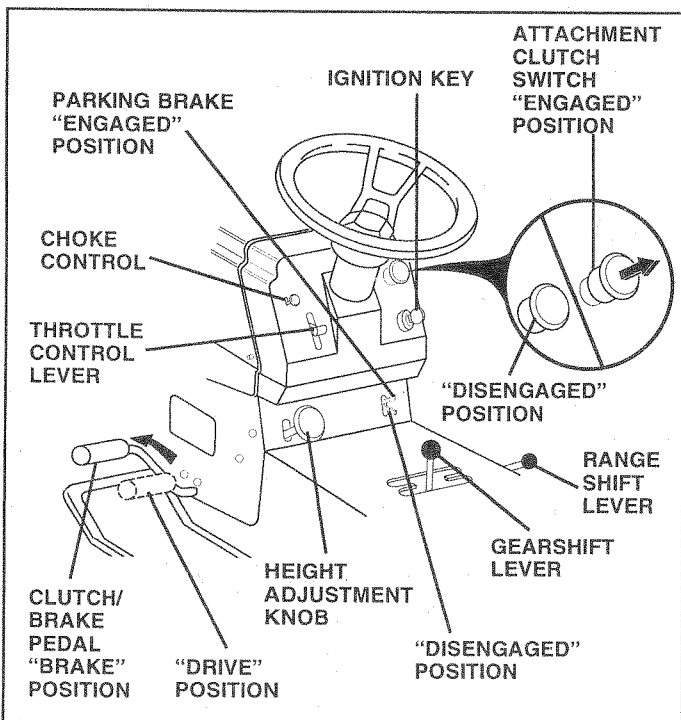

FIG. 8

NOTE: Under certain conditions when tractor is standing idle with the engine running, hot engine exhaust gases may cause "browning" of grass. To eliminate this possibility, always stop engine when stopping tractor on grass areas.



CAUTION: Always stop tractor completely, as described above, before leaving the operator's position; to empty grass catcher, etc.

TO USE THROTTLE CONTROL (See Fig. 8)

Always operate engine at full throttle.

- Operating engine at less than full throttle reduces the battery charging rate.
- Full throttle offers the best mower performance.

TO USE CHOKER CONTROL (See Fig. 8)

Use choke control whenever you are starting a cold engine. Do not use to start a warm engine.

- To engage choke control, pull knob out. Slowly push knob in to disengage.

TO MOVE FORWARD AND BACKWARD (See Fig. 8)

The direction and speed of movement is controlled by the gearshift lever.

- Start tractor with clutch/brake pedal depressed and gearshift lever in neutral (N) position.
- Move gearshift and range shift levers to desired position.
- Slowly release clutch/brake pedal to start movement.

IMPORTANT: BRING TRACTOR TO A COMPLETE STOP BEFORE SHIFTING OR CHANGING GEARS. FAILURE TO DO SO WILL SHORTEN THE USEFUL LIFE OF YOUR TRANSAXLE.

TO ADJUST MOWER CUTTING HEIGHT (See Fig. 8)

The cutting height is controlled by turning the height adjustment knob in desired direction.

- Turn knob clockwise (↻) to raise cutting height.
- Turn knob counterclockwise (↺) to lower cutting height.

The cutting height range is approximately 1-1/4" to 4-1/4". The heights are measured from the ground to the blade tip with the engine not running. These heights are approximate and may vary depending upon soil conditions, height of grass and types of grass being mowed.

- The average lawn should be cut to approximately 2-1/2 inches during the cool season and to over 3 inches during hot months. For healthier and better looking lawns, mow often and after moderate growth.
- For best cutting performance, grass over 6 inches in height should be mowed twice. Make the first cut relatively high; the second to desired height.

STOPPING (See Fig. 8)

MOWER BLADES -

- Move attachment clutch switch to "DISENGAGED" position.

GROUND DRIVE -

- Depress clutch/brake pedal into full "BRAKE" position.
- Move gearshift lever to neutral (N) position.

ENGINE -

- Move throttle control to slow (🐢) position.

NOTE: Failure to move throttle control to slow (🐢) position and allowing engine to idle before stopping may cause engine to "backfire".

- Turn ignition key to "OFF" position and remove key. Always remove key when leaving tractor to prevent unauthorized use.
- Never use choke to stop engine.

OPERATION

TO ADJUST GAUGE WHEELS (See Fig. 9)

- Adjust mower to desired cutting height.
- Lower mower with lift control. Remove rear retainer spring and clevis pin which secure each gauge wheel.
- Lower gauge wheels to ground. Raise gauge wheels slightly to align holes in bracket and gauge wheel bar and insert clevis pins. Gauge wheels should be slightly off the ground.
- Replace retainer springs into clevis pins.

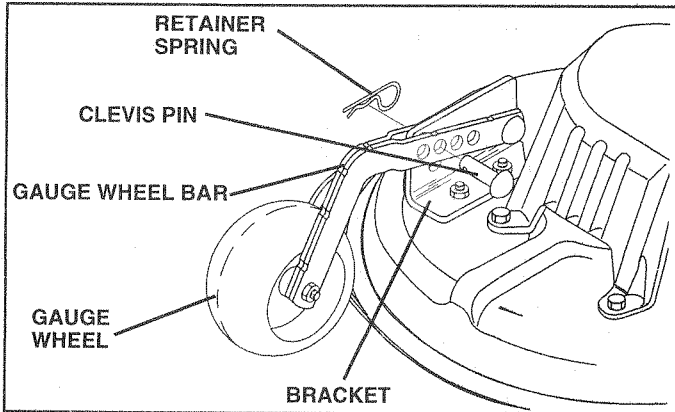

FIG. 9

TO OPERATE MOWER (See Figs. 7 and 8)

Your unit is equipped with an operator presence sensing switch. Any attempt by the operator to leave the seat with the engine running and the attachment clutch engaged will shut off the engine.

- Select desired height of cut.
- Lower mower with attachment lift control.
- Start mower blades by engaging attachment clutch control.
- TO STOP MOWER BLADES - disengage attachment clutch control.



CAUTION: Do not operate the mower without either the entire grass catcher, on mowers so equipped, or the discharge guard in place.

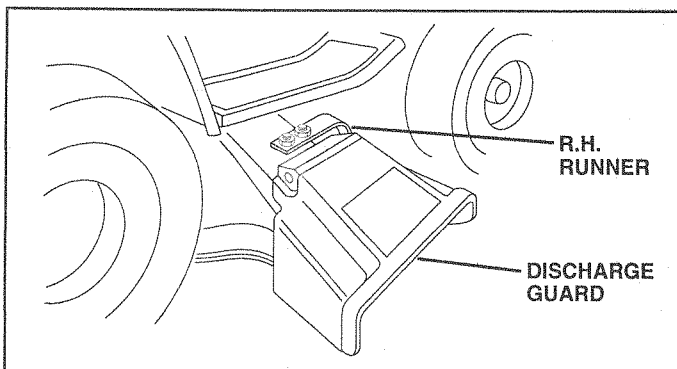

FIG. 10

TO OPERATE ON HILLS



CAUTION: Do not drive up or down hills with slopes greater than 15° and do not drive across any slope.

- Choose the slowest speed before starting up or down hills.
- Avoid stopping or changing speed on hills.
- If slowing is necessary, move throttle control lever to slower position.
- If stopping is absolutely necessary, push clutch/brake pedal quickly to brake position and engage parking brake.
- Move gearshift lever to 1st gear and range shift lever to low (L) position. Be sure you have allowed room for unit to roll slightly as you restart movement.
- To restart movement, slowly release parking brake and clutch/brake pedal.
- Make all turns slowly.

TO TRANSPORT

- Raise attachment lift to highest position with attachment lift control.
- When pushing or towing your tractor, be sure gearshift lever is in neutral (N) position.
- Do not push or tow tractor at more than five (5) MPH.

NOTE: To protect hood from damage when transporting your tractor on a truck or a trailer, be sure hood is closed and secured to tractor. Use an appropriate means of tying hood to tractor (rope, cord, etc.).

BEFORE STARTING THE ENGINE

CHECK ENGINE OIL LEVEL (See Fig. 11)

- The engine in your tractor has been shipped, from the factory, already filled with summer weight oil.
- Check engine oil with tractor on level ground.
- Remove oil fill cap/dipstick and wipe clean, reinsert the dipstick and push it all the way down into the tube, wait for a few seconds, remove and read oil level. If necessary, add oil until "FULL" mark on dipstick is reached. Do not overfill.
- For cold weather operation you should change oil for easier starting (See "OIL VISCOSITY CHART" in the Customer Responsibilities section of this manual).
- To change engine oil, see the Customer Responsibilities section in this manual.

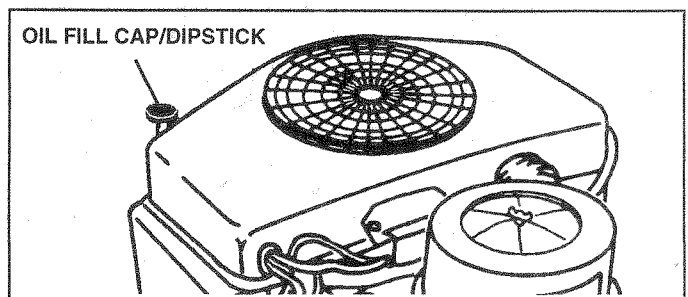

FIG. 11

OPERATION

ADD GASOLINE

- Fill fuel tank. Use fresh, clean, regular unleaded gasoline. (Use of leaded gasoline will increase carbon and lead oxide deposits and reduce valve life).

IMPORTANT: WHEN OPERATING IN TEMPERATURES BELOW 32°F(0°C), USE FRESH, CLEAN WINTER GRADE GASOLINE TO HELP INSURE GOOD COLD WEATHER STARTING.

WARNING: Experience indicates that alcohol blended fuels (called gasohol or using ethanol or methanol) can attract moisture which leads to separation and formation of acids during storage. Acidic gas can damage the fuel system of an engine while in storage. To avoid engine problems, the fuel system should be emptied before storage of 30 days or longer. Drain the gas tank, start the engine and let it run until the fuel lines and carburetor are empty. Use fresh fuel next season. See Storage Instructions for additional information. Never use engine or carburetor cleaner products in the fuel tank or permanent damage may occur.



CAUTION: Fill to bottom of gas tank filler neck. Do not overfill. Wipe off any spilled oil or fuel. Do not store, spill or use gasoline near an open flame.

TO START ENGINE (See Fig. 8)

When starting engine for the first time or if engine has run out of fuel, it will take extra cranking time to move fuel from the tank to the engine.

- Depress clutch/brake pedal and set parking brake.
- Place gearshift lever in neutral (N) position.
- Move attachment clutch to "DISENGAGED" position.
- Pull choke control out to choke (I\|) position for cold engine start. For warm engine start do not use choke control.
- Move throttle control to midway between fast (↻) and slow (↻) positions.
- Insert key into ignition and turn key clockwise to "START" position and release key as soon as engine starts. Do not run starter continuously for more than fifteen seconds per minute. If engine does not start after several attempts, move throttle control to fast (↻) position, wait a few minutes and try again.
- When engine starts, slowly push choke control in.
- Move throttle control to fast (↻) position.
- Allow engine to warm up for a few minutes before engaging drive or attachments.

NOTE: If at a high altitude (above 3000 feet) or in cold temperatures (below 32°F), the carburetor fuel mixture may need to be adjusted for best engine performance. See "TO ADJUST CARBURETOR" in the Service and Adjustments section of this manual.

MOWING TIPS

- Tire chains cannot be used when the mower housing is attached to unit.
- Mower should be properly leveled for best mowing performance. See "TO LEVEL MOWER HOUSING" in the Service and Adjustments section of this manual.
- Use the runner on the right hand side of mower as a guide. The blade cuts approximately an inch outside the runner (See Fig. 10).
- The left hand side of mower should be used for trimming.
- Drive so that clippings are discharged onto the area that has been cut. Have the cut area to the right of the machine. This will result in a more even distribution of clippings and more uniform cutting.
- When mowing large areas, start by turning to the right so that clippings will discharge away from shrubs, fences, driveways, etc. After one or two rounds, mow in the opposite direction making left hand turns until finished (See Fig. 12).
- If grass is extremely tall, it should be mowed twice to reduce load and possible fire hazard from dried clippings. Make first cut relatively high; the second to the desired height.
- Do not mow grass when it is wet. Wet grass will plug mower and leave undesirable clumps. Allow grass to dry before mowing.
- Always operate engine at full throttle when mowing to assure better mowing performance and proper discharge of material. Regulate ground speed by selecting a low enough gear to give the mower cutting performance as well as the quality of cut desired.
- When operating attachments, select a ground speed that will suit the terrain and give best performance of the attachment being used.

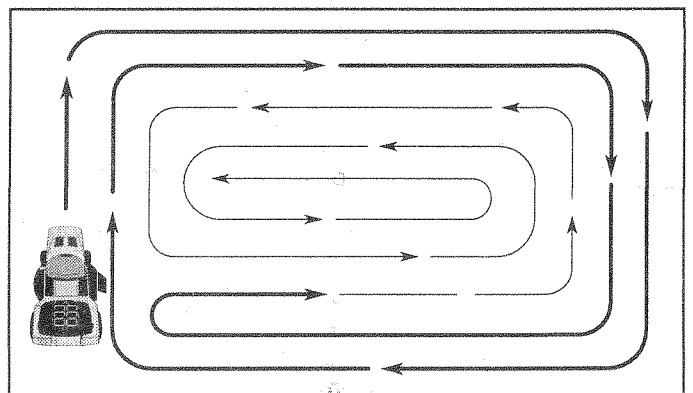

FIG. 12

CUSTOMER RESPONSIBILITIES

MAINTENANCE SCHEDULE FILL IN DATES AS YOU COMPLETE REGULAR SERVICE		SERVICE INTERVALS							SERVICE DATES			
		BEFORE EACH USE	FIRST 2 HOURS	EVERY 8 HOURS	EVERY 25 HOURS	EVERY 50 HOURS	EVERY 100 HOURS	EVERY SEASON				BEFORE STORAGE
TRACTOR	Check Brake Operation	✓		✓								
	Check Tire Pressure	✓		✓								
	Check for Loose Fasteners	✓							✓			
	Sharpen/Replace Mower Blades				✓ ₄							
	Lubrication Chart			✓					✓			
	Check Battery Level/Recharge			✓								
	Clean Battery and Terminals			✓					✓			
	Check Transaxle Cooling			✓								
	Adjust Blade Belt(s) Tension						✓ ₅					
	Adjust Motion Drive Belt(s) Tension						✓ ₅					
ENGINE	Check Engine Oil Level	✓		✓								
	Change Engine Oil		✓		✓ _{1,2,3}				✓			
	Clean Air Filter				✓ ₂							
	Clean Air Screen				✓ ₂							
	Inspect Muffler/Spark Arrester					✓						
	Replace Oil Filter (If equipped)						✓ _{1,2}					
	Clean Engine Cooling Fins						✓ ₂					
	Replace Spark Plug						✓		✓			
	Replace Air Filter Paper Cartridge						✓ ₂					
	Replace Fuel Filter								✓			

1 - Change more often when operating under a heavy load or in high ambient temperatures.
2 - Service more often when operating in dirty or dusty conditions.

3 - If equipped with oil filter, change oil every 50 hours.
4 - Replace blades more often when mowing in sandy soil.
5 - If equipped with adjustable system.

GENERAL RECOMMENDATIONS

The warranty on this tractor does not cover items that have been subjected to operator abuse or negligence. To receive full value from the warranty, operator must maintain tractor as instructed in this manual.

Some adjustments will need to be made periodically to properly maintain your tractor.

All adjustments in the Service and Adjustments section of this manual should be checked at least once each season.

- Once a year you should replace the spark plug, clean or replace air filter, and check blades and belts for wear. A new spark plug and clean air filter assure proper air-fuel mixture and help your engine run better and last longer.

BEFORE EACH USE

- Check engine oil level.
- Check brake operation.
- Check tire pressure.
- Check for loose fasteners.

IMPORTANT: DO NOT OIL OR GREASE THE PIVOT POINTS WHICH HAVE SPECIAL NYLON BEARINGS. VISCOUS LUBRICANTS WILL ATTRACT DUST AND DIRT THAT WILL SHORTEN THE LIFE OF THE SELF-LUBRICATING BEARINGS. IF YOU FEEL THEY MUST BE LUBRICATED, USE ONLY A DRY, POWDERED GRAPHITE TYPE LUBRICANT SPARINGLY.

LUBRICATION CHART

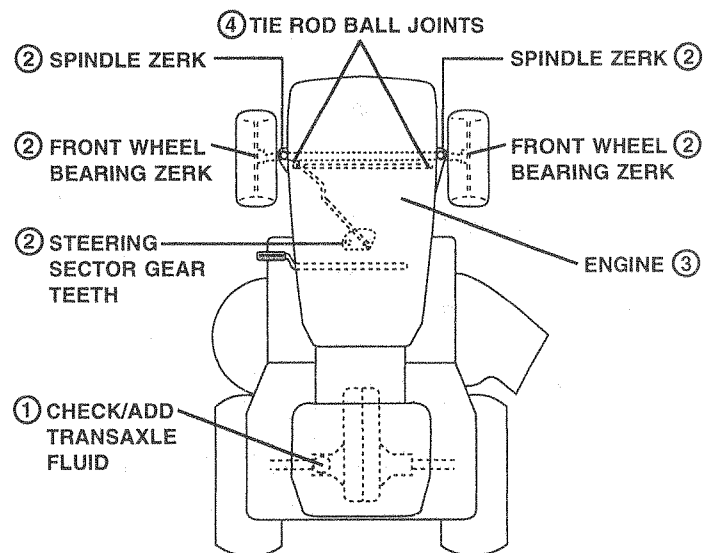

- ① SAE 30 MOTOR OIL API - SG
- ② GENERAL PURPOSE GREASE
- ③ REFER TO CUSTOMER RESPONSIBILITIES "ENGINE" SECTION
- ④ SPRAY SILICONE LUBRICANT (MOVE BOOTS TO LUBRICATE)

CUSTOMER RESPONSIBILITIES

TRACTOR

Always observe safety rules when performing any maintenance.

BRAKE OPERATION

If unit requires more than six (6) feet stopping distance at high speed in highest gear, then brake must be adjusted. (See "TO ADJUST BRAKE" in the Service and Adjustments section of this manual).

TIRES

- Maintain proper air pressure in all tires (See "PRODUCT SPECIFICATIONS" on page 3 of this manual).
- Keep tires free of gasoline, oil, or insect control chemicals which can harm rubber.
- Avoid stumps, stones, deep ruts, sharp objects and other hazards that may cause tire damage.

BLADE CARE

For best results mower blades must be kept sharp. Replace bent or damaged blades.

BLADE REMOVAL (See Fig. 13)

- Raise mower to highest position to allow access to blades.
- Remove hex bolt, lock washer and flat washer securing blade.
- Install new or resharpened blade with trailing edge up towards deck as shown.
- Reassemble hex bolt, lock washer and flat washer in exact order as shown.
- Tighten bolt securely (30-35 Ft. Lbs. torque).

IMPORTANT: BLADE BOLT IS GRADE 8 HEAT TREATED.

NOTE: We do not recommend sharpening blade - but if you do, be sure the blade is balanced.

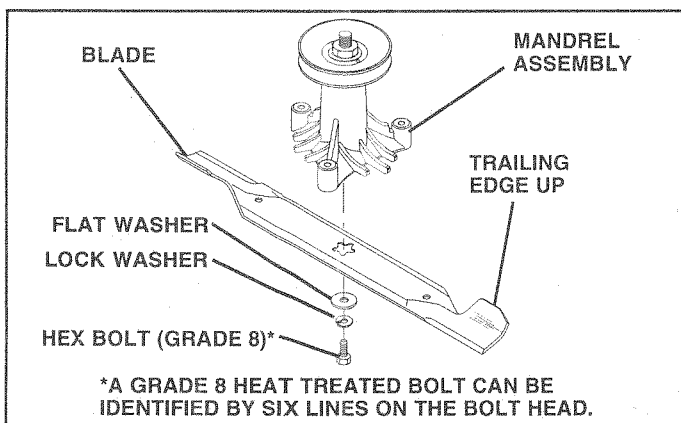

FIG. 13

TO SHARPEN BLADE (See Fig. 14)

Care should be taken to keep the blade balanced. An unbalanced blade will cause excessive vibration and eventual damage to mower and engine.

- The blade can be sharpened with a file or on a grinding wheel. Do not attempt to sharpen while on the mower.
- To check blade balance, you will need a 5/8" diameter steel bolt, pin, or a cone balancer. (When using a cone balancer, follow the instructions supplied with balancer).
- Slide blade on to an unthreaded portion of the steel bolt or pin and hold the bolt or pin parallel with the ground. If blade is balanced, it should remain in a horizontal position. If either end of the blade moves downward, sharpen the heavy end until the blade is balanced.

NOTE: Do not use a nail for balancing blade. The lobes of the center hole may appear to be centered, but are not.

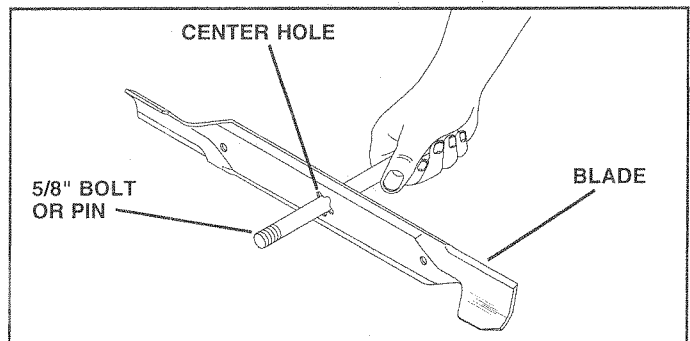

FIG. 14

V-BELTS

Check V-belts for deterioration and wear after 100 hours and replace if necessary. The belts are not adjustable. Replace belts if they begin to slip from wear.

TRANSAXLE COOLING

Keep transaxle free from build-up of dirt and chaff which can restrict cooling.

CHECK TRANSAXLE OIL LEVEL (See Fig. 15)

- Block up rear axle securely or use a tractor jack.
- Remove left rear wheel by removing hub bolts.
- Remove filler plug from transaxle. Oil level must be even with plug threads. If necessary, fill with SAE 30 motor oil, API-SG. Replace filler plug.
- Reassemble wheel to hub.
- For approximate capacity see "PRODUCT SPECIFICATIONS" on page 3 of this manual.

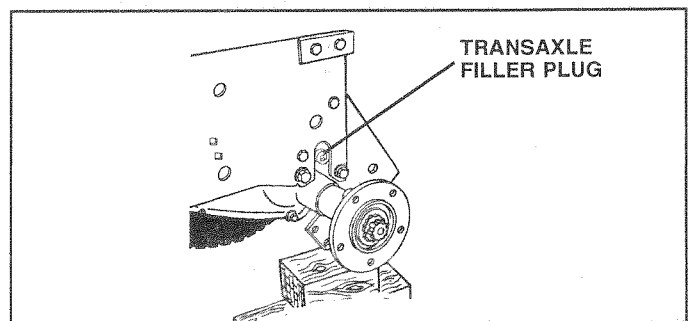

FIG. 15

CUSTOMER RESPONSIBILITIES

BATTERY (See Fig. 16)

Your unit has a battery charging system which is sufficient for normal use. However, periodic charging of the battery with an automotive charger will extend its life.

- Acid solution level in each battery cell should be even with bottoms of vent wells. Add only distilled or iron free water if necessary. Do not overfill.
- Keep battery and terminals clean.
- Keep battery bolts tight.
- Keep vent caps tight and small vent holes in caps open.
- Recharge at 6 amperes for 1 hour.

TO CLEAN BATTERY AND TERMINALS -

Corrosion and dirt on the battery and terminals can cause the battery to "leak" power.

- Remove terminal guard.
- Disconnect BLACK battery cable first then RED battery cable and remove battery from tractor.
- Wash battery with solution of four tablespoons of baking soda to one gallon of water. Be careful not to get the soda solution into the cells.
- Rinse the battery with plain water and dry.
- Clean terminals and battery cable ends with wire brush until bright.
- Coat terminals with grease or petroleum jelly.
- Reinstall battery (See "INSTALL BATTERY" in the Assembly section of this manual).

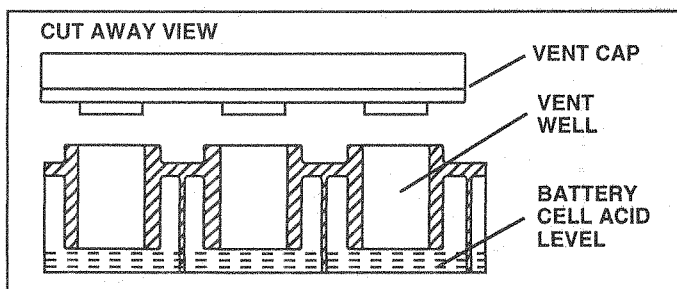

FIG. 16

ENGINE

LUBRICATION

Only use high quality detergent oil rated with API service classification SG. Select the oil's SAE viscosity grade according to your expected operating temperature.

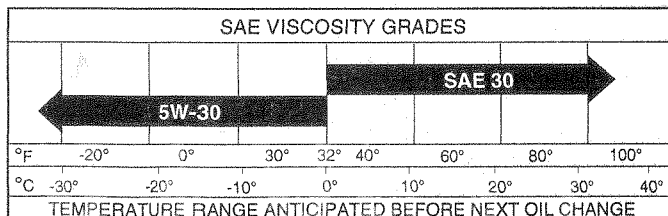

FIG. 17

NOTE: Although multi-viscosity oils (5W30, 10W30 etc.) improve starting in cold weather, these multi-viscosity oils will result in increased oil consumption when used above 32°F. Check your engine oil level more frequently to avoid possible engine damage from running low on oil.

Change the oil after the first two hours of operation and every 50 hours thereafter or at least once a year if the tractor is not used for 50 hours in one year.

Check the crankcase oil level before starting the engine and after each eight (8) hours of operation. Tighten oil fill cap/dipstick securely each time you check the oil level.

TO CHANGE ENGINE OIL (See Figs. 17 and 18)

Determine temperature range expected before oil change. All oil must meet API service classification SG.

- Be sure tractor is on level surface.
- Oil will drain more freely when warm.
- Catch oil in a suitable container.
- Remove oil fill cap/dipstick. Be careful not to allow dirt to enter the engine when changing oil.
- Remove drain plug.
- After oil has drained completely, replace oil drain plug and tighten securely.
- Refill engine with oil through oil fill dipstick tube. Pour slowly. Do not overfill. For approximate capacity see "PRODUCT SPECIFICATIONS" on page 3 of this manual.
- Use gauge on oil fill cap/dipstick for checking level. Be sure dipstick is in all the way for accurate reading. Keep oil at "FULL" line on dipstick.

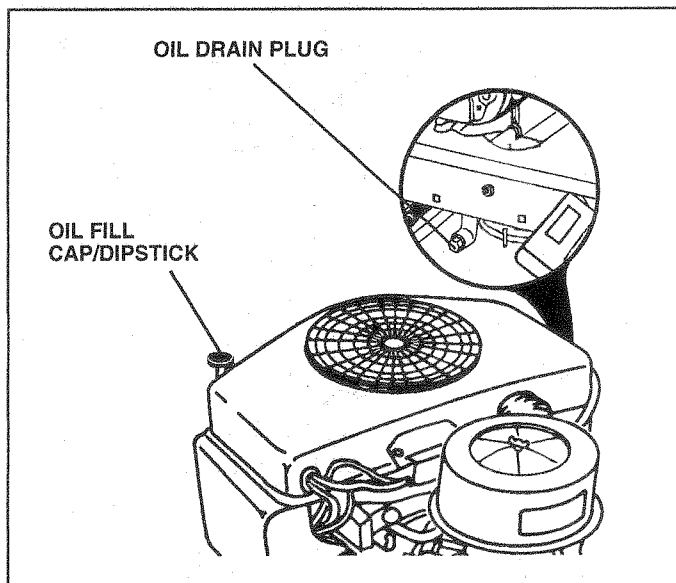

FIG. 18

CUSTOMER RESPONSIBILITIES

CLEAN AIR SCREEN (See Fig. 19)

Air screen must be kept free of dirt and chaff to prevent engine damage from overheating. Clean with a wire brush or compressed air to remove dirt and stubborn dried gum fibers.

ENGINE COOLING FINS (See Fig. 19)

Remove any dust, dirt or oil from engine cooling fins to prevent engine damage from overheating. Engine blower housing must be removed. Remove side panels and hood (See "TO REMOVE HOOD AND GRILL ASSEMBLY" in the Service and Adjustments section of this manual).

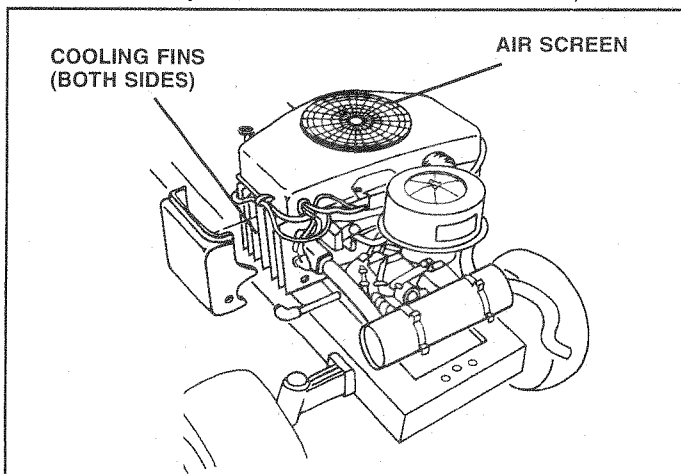

FIG. 19

AIR FILTER (See Fig. 20)

Your engine will not run properly using a dirty air filter. Clean the foam pre-cleaner element after every 25 hours of operation or every season. Service paper cartridge every 100 hours or every season, whichever occurs first.

Service air cleaner more often under dusty conditions.

- Remove wing nut and cover.
- Remove seal and cartridge plate.

TO SERVICE PRE-CLEANER

- Slide foam pre-cleaner off cartridge.
- Wash it in liquid detergent and water.
- Squeeze it dry in a clean cloth.
- Saturate it in engine oil. Wrap it in clean, absorbent cloth and squeeze to remove excess oil.

TO SERVICE CARTRIDGE

- Gently tap the flat side of the paper cartridge to dislodge dirt. Do not wash the paper cartridge or use pressurized air, as this will damage the cartridge. Replace a dirty, bent, or damaged cartridge.
- Reinstall the pre-cleaner (cleaned and oiled) over the paper cartridge.
- Reassemble air cleaner, cartridge plate, and seal.
- Install the air cleaner cover and wing nut. Tighten wing nut 1/2 turn to 1 full turn after nut contacts cover. Do not overtighten.

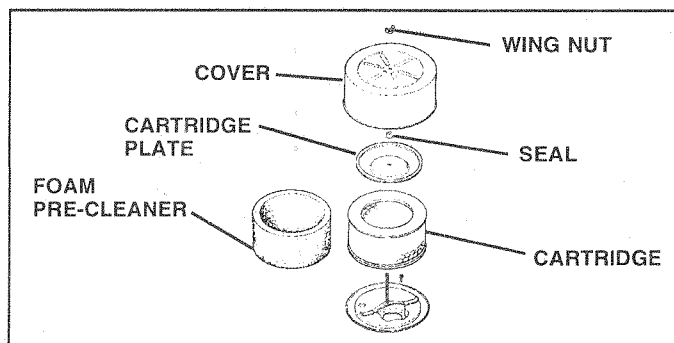

FIG. 20

MUFFLER

Inspect and replace corroded muffler and spark arrester (if equipped) as it could create a fire hazard and/or damage.

SPARK PLUGS

Replace spark plugs at the beginning of each mowing season or after every 100 hours of operation, whichever comes first. Spark plug type and gap setting are shown in "PRODUCT SPECIFICATIONS" on page 3 of this manual.

ENGINE OIL FILTER

Replace the engine oil filter every season or every other oil change if the tractor is used more than 100 hours in one year.

IN-LINE FUEL FILTER (See Fig. 21)

The fuel filter should be replaced once each season. If fuel filter becomes clogged, obstructing fuel flow to carburetor, replacement is required.

- With engine cool, remove filter and plug fuel line sections.
- Place new fuel filter in position in fuel line with arrow pointing towards carburetor.
- Be sure there are no fuel line leaks and clamps are properly positioned.
- Immediately wipe up any spilled gasoline.

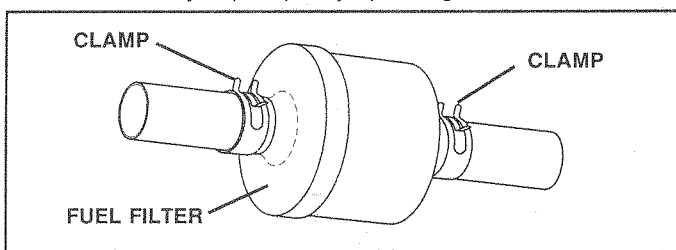

FIG. 21

CLEANING

- Clean engine, battery, seat, finish, etc. of all foreign matter.
- Keep finished surfaces and wheels free of all gasoline, oil, etc.
- Protect painted surfaces with automotive type wax.

We do not recommend using a garden hose to clean your tractor unless the electrical system, muffler, air filter and carburetor are covered to keep water out. Water in engine can result in a shortened engine life.

SERVICE AND ADJUSTMENTS



CAUTION: BEFORE PERFORMING ANY SERVICE OR ADJUSTMENTS:

- Depress clutch/brake pedal fully and set parking brake.
- Place gearshift lever in neutral (N) position.
- Place attachment clutch in "DISENGAGED" position.
- Turn ignition key "OFF" and remove key.
- Make sure the blades and all moving parts have completely stopped.
- Disconnect spark plug wire from spark plug and place wire where it cannot come in contact with plug.

TRACTOR

TO REMOVE MOWER (See Fig. 22)

- Place attachment clutch in "DISENGAGED" position.
- Turn height adjustment knob to lowest setting.
- Lower mower to its lowest position.
- Remove retainer spring holding anti-swaybar to chassis bracket and disengage anti-swaybar from bracket.
- Remove retainer springs from suspension arms at deck and disengage arms from deck.
- Raise attachment lift to its highest position.
- Remove two retainer springs from each front link and remove links.
- Slide mower forward and remove belt from electric clutch pulley.
- Slide mower out from under right side of tractor.

IMPORTANT: IF AN ATTACHMENT OTHER THAN THE MOWER DECK IS TO BE MOUNTED ON THE TRACTOR, REMOVE THE FRONT LINKS.

TO INSTALL MOWER

Follow procedure described in "INSTALL MOWER AND DRIVE BELT" in the Assembly section of this manual.

TO LEVEL MOWER HOUSING

Adjust the mower while tractor is parked on level ground or driveway. Make sure tires are properly inflated (See "PRODUCT SPECIFICATIONS" on page 3 of this manual). If tires are over or underinflated, you will not properly adjust your mower.

SIDE-TO-SIDE ADJUSTMENT (See Figs. 22 and 23)

- Raise mower to its highest position.
- Measure height from bottom of deck curl to ground level at front corners of mower. Distance "A" should be the same.
- If distance "A" needs to be changed, make adjustment on one side of mower only.
- Raise one side of mower by tightening lift link adjustment nut on that side.
- Lower one side of mower by loosening lift link adjustment nut on that side.

NOTE: Each half turn of adjustment nut will change deck level about 1/4".

- Recheck level after adjusting.

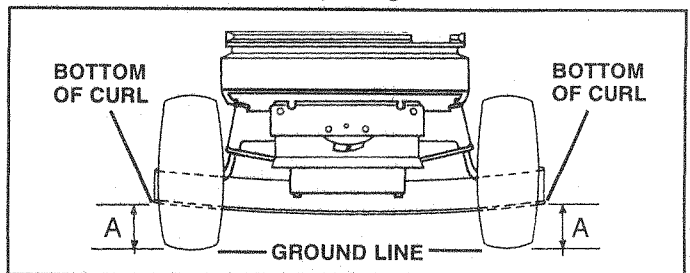

FIG. 23

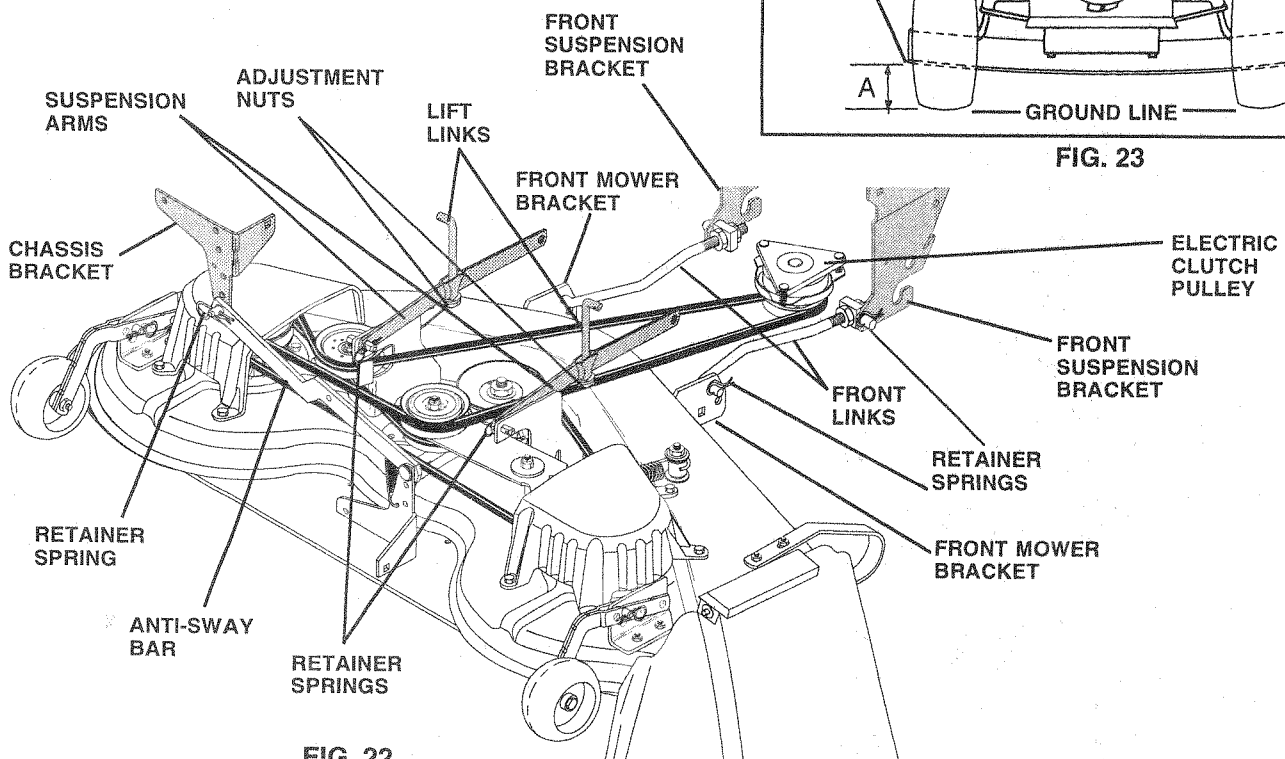

FIG. 22

SERVICE AND ADJUSTMENTS

FRONT-TO-BACK ADJUSTMENT (See Figs. 24 and 25) - **IMPORTANT:** DECK MUST BE LEVEL SIDE-TO-SIDE. IF THE FOLLOWING FRONT-TO-BACK ADJUSTMENT IS NECESSARY, BE SURE TO ADJUST BOTH FRONT LINKS EQUALLY SO MOWER WILL STAY LEVEL SIDE-TO-SIDE. To obtain the best cutting results, the mower housing should be adjusted so the front is approximately 1/8" to 1/2" lower than the rear when the mower is in its highest position.

Check adjustment on right side of tractor. Measure distance "F" directly in front of and behind the mandrel at bottom edge of mower housing as shown.

- Before making any necessary adjustments, check that both front links are equal in length.
- If links are not equal in length, adjust one link to same length as other link.
- To lower front of mower housing, loosen nut "G" on both front links an equal number of turns.
- When distance "F" is 1/8" to 1/2" lower at front than rear, tighten nut "H" against trunnion on both front links.
- To raise front of mower housing, loosen nut "H" from trunnion on both front links. Tighten nut "G" on both front links an equal number of turns.
- When distance "F" is 1/8" to 1/2" lower at front than rear, tighten nut "H" against trunnion on both front links.

NOTE: Each full turn of nut "G" will change dim. "F" by approximately 3/8".

- Recheck side-to-side adjustment.

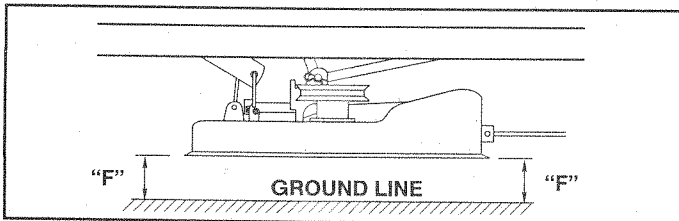

FIG. 24

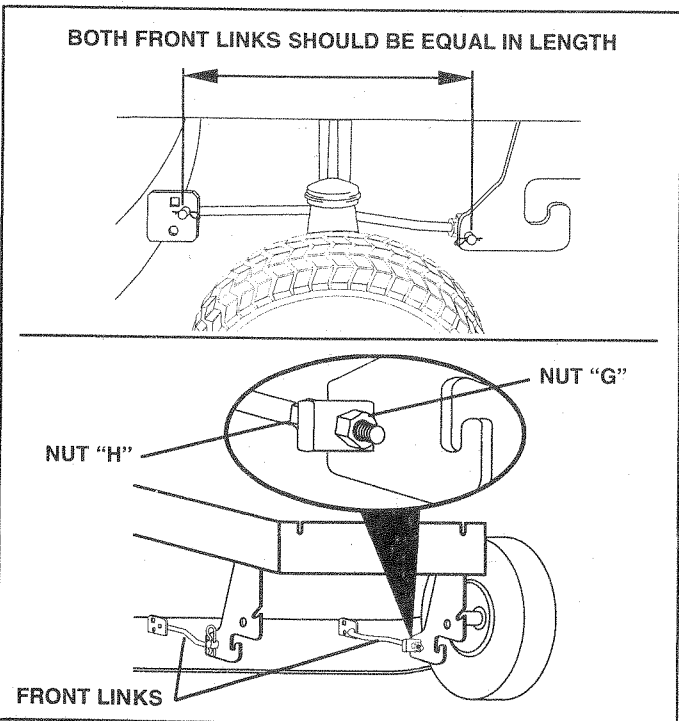

FIG. 25

TO REPLACE MOWER DRIVE BELT

MOWER DRIVE BELT REMOVAL (See Fig. 26) -

- Park tractor on a level surface. Engage parking brake.
- Remove four screws from L.H. mandrel cover and remove cover.
- Roll belt over the top of L.H. mandrel pulley.
- Remove belt from electric clutch pulley.
- Remove belt from idler pulleys.
- Remove any dirt or grass clippings which may have accumulated around mandrels and entire upper deck surface.
- Check primary idler arm and two idlers to see that they rotate freely.
- Be sure spring is securely hooked to primary idler arm and bolt in mower housing.

MOWER DRIVE BELT INSTALLATION (See Fig. 26) -

- Install belt in both idlers. Make sure belt is in both belt keepers at the idlers as shown.
- Install new belt onto electric clutch pulley.
- Roll belt into upper groove of L.H. mandrel pulley.
- Carefully check belt routing making sure belt is in the grooves correctly and inside belt keepers.
- Reassemble L.H. mandrel cover.

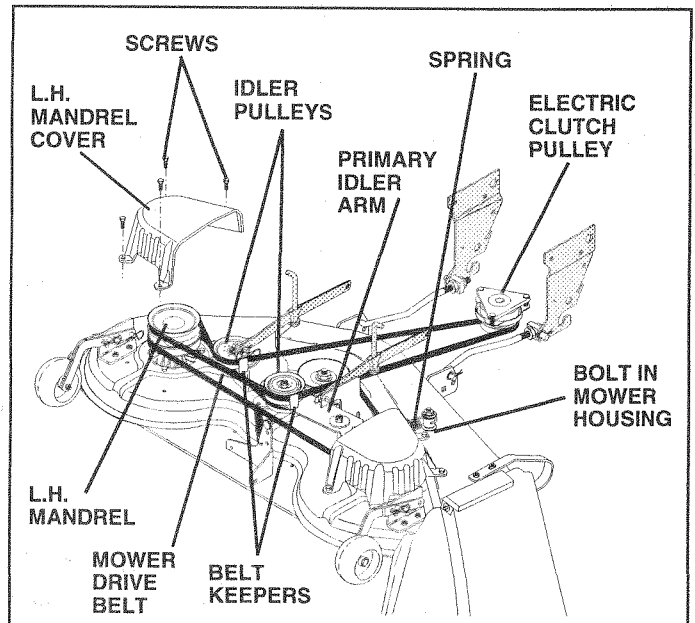

FIG. 26

SERVICE AND ADJUSTMENTS

TO REPLACE MOWER BLADE DRIVE BELT (See Fig. 27)

Park the tractor on level surface. Engage parking brake.

- Remove mower drive belt (See "TO REPLACE MOWER DRIVE BELT" in this section of this manual).
- Remove mower (See "TO REMOVE MOWER" in this section of this manual).
- Remove four screws from R.H. mandrel cover and remove cover. Unhook spring from bolt on mower housing.
- Carefully roll belt off R.H. mandrel pulley.
- Remove belt from center mandrel pulley, idler pulley, and L.H. mandrel pulley.
- Remove any dirt or grass which may have accumulated around mandrels and entire upper deck surface.
- Check secondary idler arm and idler to see that they rotate freely.
- Be sure spring is hooked in secondary idler arm and sway-bar bracket.
- Install new belt in lower groove of L.H. mandrel pulley, idler pulley, and center mandrel pulley as shown.
- Roll belt over R.H. mandrel pulley. Make sure belt is in all grooves properly.
- Reconnect spring to bolt in mower housing and reinstall R.H. mandrel cover.
- Reinstall mower to tractor (See "TO INSTALL MOWER" in the Assembly section of this manual).
- Reassemble mower drive belt (See "TO REPLACE MOWER DRIVE BELT" in this section of this manual).

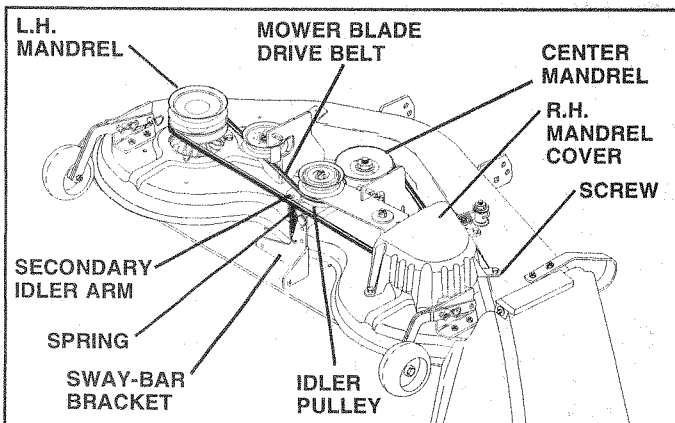

FIG. 27

TO ADJUST ATTACHMENT CLUTCH (See Fig. 28)

The electric clutch should provide years of service. The clutch has a built-in brake that stops the pulley within 5 seconds. Eventually, the internal brake will wear which may cause the mower blades to not engage, or, to not stop as required. Adjustments should be made by your nearest authorized service center/department.

- Make sure attachment clutch and ignition switches are in "OFF" position.
- Adjust the three nylon locknuts until space between clutch plate and rotor measures .012" at all three slot locations cut inside of brake plate.

NOTE: After installing a new electric clutch, run tractor at full throttle and engage and disengage electric clutch 10 cycles to wear in clutch plate.

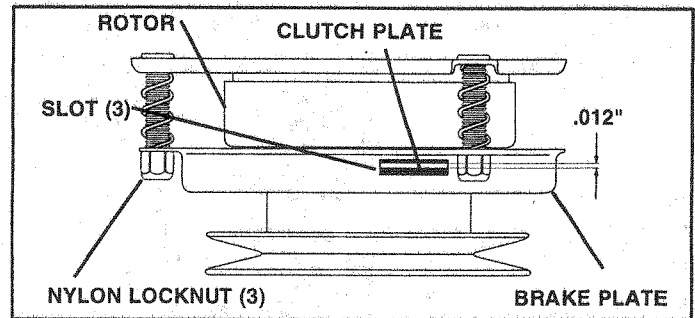

FIG. 28

TO ADJUST BRAKE (See Fig. 29)

Your tractor is equipped with an adjustable brake system which is mounted on the left side of the transaxle.

If tractor requires more than six (6) feet stopping distance at high speed in highest gear, then brake must be adjusted.

- Depress clutch/brake pedal and engage parking brake.
- Measure distance between brake operating arm and nut "A" on brake rod.
- If distance is other than 1-3/4", loosen jam nut and turn nut "A" until distance becomes 1-3/4". Retighten jam nut against nut "A".
- Road test tractor for proper stopping distance as stated above. Readjust if necessary. If stopping distance is still greater than six (6) feet in highest gear, further maintenance is necessary. Contact your nearest authorized service center/department.

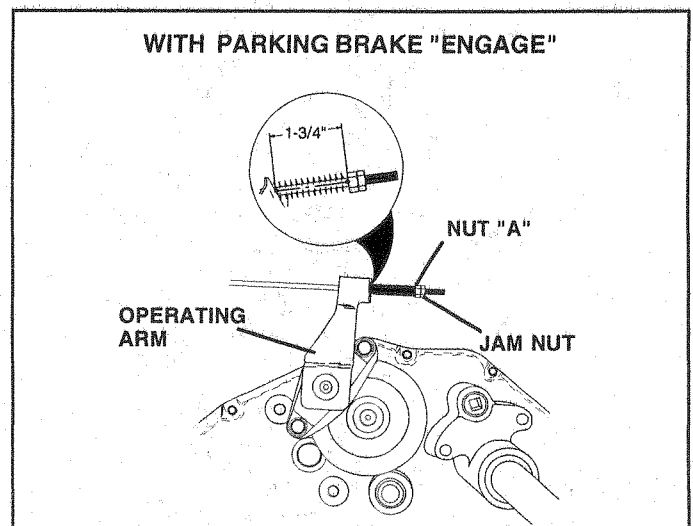

FIG. 29

SERVICE AND ADJUSTMENTS

TO REPLACE MOTION DRIVE BELT (See Fig. 30)

Park the tractor on level surface. Engage parking brake. For ease of service there is a belt installation guide decal on bottom of left footrest. It is not necessary to remove mower.

BELT REMOVAL -

- Raise hood and disconnect BLACK (grounding) battery cable.
- Set parking brake (to get belt slack).
- Remove mower drive belt from electric clutch pulley only (See "TO REPLACE MOWER DRIVE BELT" in this section of this manual).
- Roll motion drive belt off transaxle pulley.
- Roll belt off clutching idler pulleys, then off engine pulley and front V-idler pulley.
- Pull belt out of all belt keepers.

BELT INSTALLATION -

- Place V part of belt into grooves on engine pulley and front V-idler, making sure to route belt inside of belt keepers.
- Put belt coming from V-idler above midspan belt keeper, then onto clutching idler pulleys as shown.
- Make sure "V" part of belt engages "V" idler.
- Place belt around transaxle pulley, beginning at top. "V" part of belt should engage transaxle pulley.
- Place long lower section of belt through loop in midspan belt keeper.
- Check to be sure belt is on proper side of all belt keepers.
- Reinstall mower drive belt onto electric clutch pulley.
- Release parking brake.

IMPORTANT: CHECK BRAKE ADJUSTMENT.

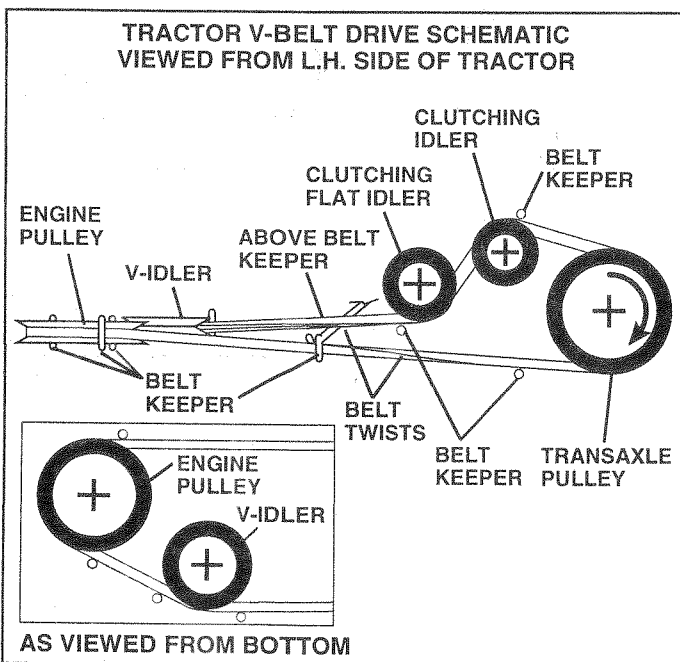

FIG. 30

TO ADJUST STEERING WHEEL ALIGNMENT

If steering wheel crossbars are not horizontal (left to right) when wheels are positioned straight forward, remove steering wheel and reassemble per instructions in the Assembly section of this manual.

FRONT WHEEL TOE-IN ADJUSTMENT

Front wheel toe-in is required for proper steering operation. Toe-in was set at the factory and adjustment should not be necessary. If parts in the front axle or steering mechanism have been replaced or damaged, check toe-in and adjust if necessary.

TO CHECK TOE-IN (See Fig. 31) -

- Position front wheels straight ahead.
- Measure distance between wheels at front and rear of tires (dimensions "A" and "B").
- Front dimension "A" should be 1/8" to 1/4" less than rear dimension "B".

TO ADJUST TOE-IN (See Figs. 31 and 32) -

- Loosen jam nuts at adjustment sleeves on tie rod.
- Adjust tie rod until dimension "A" is 1/8" to 1/4" less than dimension "B".
- Tighten jam nuts securely.

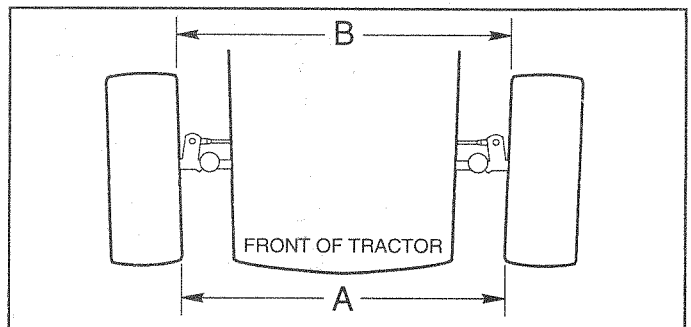

FIG. 31

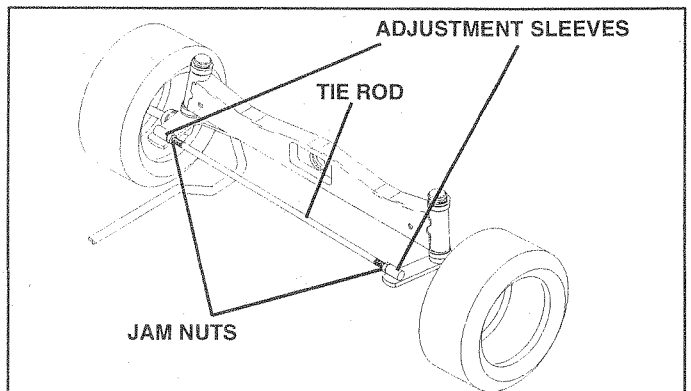

FIG. 32

FRONT WHEEL CAMBER

The front wheel camber is not adjustable on your tractor. If damage has occurred to affect the front wheel camber, contact your nearest authorized service center/department.

SERVICE AND ADJUSTMENTS

TO REMOVE WHEEL FOR REPAIRS

FRONT WHEEL (See Fig. 33) -

- Block up axle securely.
- Remove axle cover, retaining ring and washers to allow wheel removal.
- Repair tire and reassemble.
- Replace washers and snap retaining ring securely in axle groove.
- Replace axle cover.

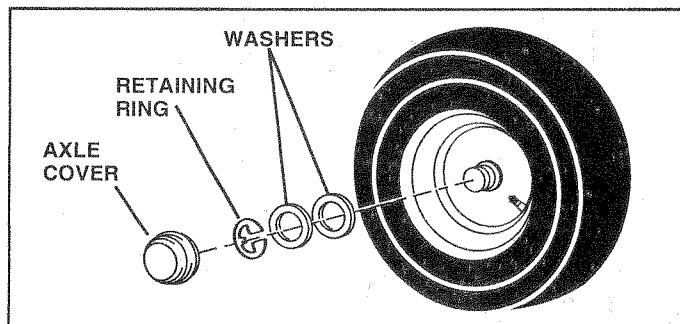

FIG. 33

REAR WHEEL -

- Block rear axle securely.
- Remove five (5) hub bolts to allow wheel removal.
- Repair tire and reassemble. Replace and tighten hub bolts securely.

TO START ENGINE WITH A WEAK BATTERY (See Figs. 34 and 35)



CAUTION: Lead-acid batteries generate explosive gases. Keep sparks, flame and smoking materials away from batteries. Always wear eye protection when around batteries.

If your battery is too weak to start the engine, it should be recharged. If "jumper cables" are used for emergency starting, follow this procedure:

IMPORTANT: YOUR TRACTOR IS EQUIPPED WITH A 12 VOLT NEGATIVE GROUND SYSTEM. THE OTHER VEHICLE MUST ALSO BE A 12 VOLT NEGATIVE GROUND SYSTEM. DO NOT USE YOUR TRACTOR BATTERY TO START OTHER VEHICLES.

TO ATTACH JUMPER CABLES -

- Connect each end of the RED cable to the POSITIVE (+) terminal of each battery, taking care not to short against chassis.
- Connect one end of the BLACK cable to the NEGATIVE (-) terminal of fully charged battery.
- Connect the other end of the BLACK cable to a panel bolt on the left side of the tractor, away from fuel tank and battery.

TO REMOVE CABLES, REVERSE ORDER -

- BLACK cable first from chassis and fully charged battery.
- RED cable last from both batteries.

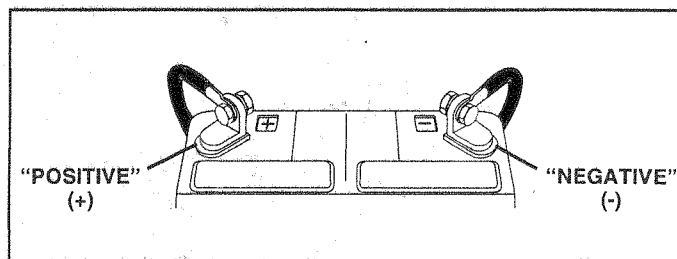

FIG. 34

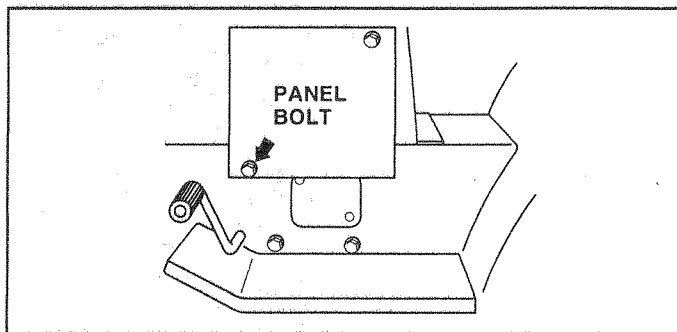

FIG. 35

TO REPLACE HEADLIGHT BULB

- Raise hood.
- Pull bulb holder out of the hole in the backside of the grill.
- Replace bulb in holder and push bulb holder securely back into the hole in the backside of the grill.
- Close hood.

INTERLOCKS AND RELAYS

Loose or damaged wiring may cause your tractor to run poorly, stop running, or prevent it from starting.

- Check wiring. See electrical wiring diagram in Repair Parts section of this manual.

TO REPLACE FUSE

Replace with 30 amp automotive-type plug-in fuse. The fuse holder is located behind the dash.

SERVICE AND ADJUSTMENTS

TO ADJUST ATTACHMENT LIFT SPRING (See Fig. 36)

- While holding spring bushing with wrench, loosen jam nut.
- Turn adjustment bolt clockwise to extend spring and reduce lift effort (for heavier attachments).
- Turn adjustment bolt counterclockwise for lighter attachments.
- Retighten jam nut against spring bushing.

IMPORTANT: DO NOT ADJUST FOR MAXIMUM SPRING TENSION WHEN USING LIGHT ATTACHMENTS SUCH AS A MOWER. ADJUST LIFT LEVER SPRING TO AID IN LIFTING ATTACHMENT. DO NOT OVERPOWER SPRING. WHEN REMOVING ATTACHMENT, ALWAYS ADJUST SPRING TENSION TO ITS LOWEST POSITION.

TO REMOVE HOOD AND GRILL ASSEMBLY (See Fig. 37)

- Raise hood.
- Unsnap headlight wire connector.
- Stand in front of tractor. Grasp hood at sides, tilt toward engine and lift off of tractor.
- To replace, reverse above procedure.

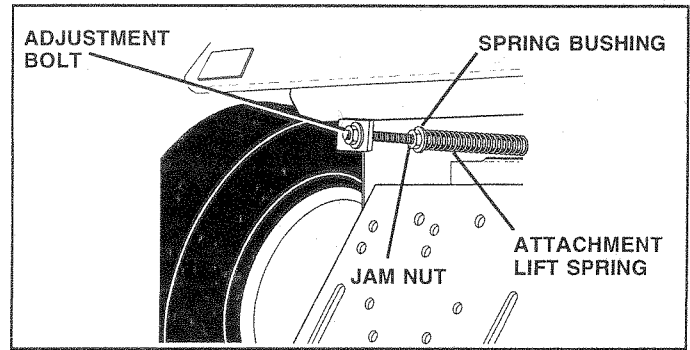

FIG. 36

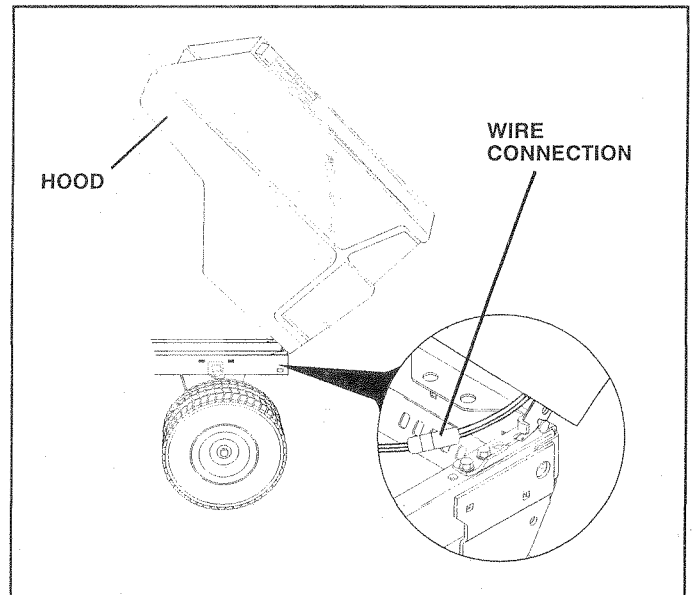

FIG. 37

SERVICE AND ADJUSTMENTS

ENGINE

TO ADJUST THROTTLE CONTROL CABLE (See Fig. 38 & 39)

The throttle control has been preset at the factory and adjustment should not be necessary. Check adjustment as described below before loosening cable. If adjustment is necessary, proceed as follows:

- With engine not running, move throttle control lever to fast (☛) position.
- Check that speed control lever is against stop screw. If it is not, loosen casing clamp screw and pull throttle cable until lever is against screw. Tighten clamp screw securely.

TO ADJUST CARBURETOR (See Fig. 40)

The carburetor has been present at the factory and adjustment should not be necessary. However, minor adjustment may be required to compensate for differences in fuel, temperature, altitude or load. If the carburetor does not need adjustment, proceed as follows:

In general, turning the adjusting needles **in** (clockwise) decreases the supply of fuel to the engine giving a leaner fuel/air mixture. Turning the adjusting needles **out** (counterclockwise) increases the supply of fuel to the engine giving a richer fuel/air mixture.

IMPORTANT: DAMAGE TO THE NEEDLES AND THE SEATS IN CARBURETOR MAY RESULT IF SCREW IS TURNED IN TOO TIGHT.

PRELIMINARY SETTING -

- Be sure you have a clean air filter, and the throttle control cable is adjusted properly (see above).
- With engine off turn idle fuel adjusting needle **in** (clockwise) closing it finger tight and then turn **out** (counterclockwise) 1-1/4 turns.
- Turn main fuel adjusting needle **in** (clockwise) closing finger tight and then turn **out** (counterclockwise) 1 turn.

FINAL SETTING -

- Start engine and allow to warm for five minutes. Make final adjustments with engine running and shift/motion control lever in neutral (N) position.
- With throttle control lever in fast (☛) position, turn main fuel adjusting needle **in** (clockwise) until engine begins to die then turn **out** (counterclockwise) until engine runs rough. Turn needle to a point midway between those two positions.
- Idle speed setting - With throttle control lever in slow (☞) position, engine should idle at 1400 RPM. If engine idles too slow or fast, turn idle speed adjusting screw in or out until correct idle is attained.
- Idle fuel needle setting - With throttle control lever in slow (☞) position, turn idle fuel adjusting needle **in** (clockwise) until engine begins to die and then turn **out** (counterclockwise) until engine runs rough. Turn needle to a point midway between those two positions.
- Recheck idle speed. Readjust if necessary.

ACCELERATION TEST -

- Move throttle control lever from slow (☞) to fast (☛) position. If engine hesitates or dies, turn idle mixture screw **out** (counterclockwise) 1/8 turn. Repeat test and continue to adjust, if necessary, until engine accelerates smoothly.

High speed stop is factory adjusted. Do not adjust-damage may result.

IMPORTANT: NEVER TAMPER WITH THE ENGINE GOVERNOR, WHICH IS FACTORY SET FOR PROPER ENGINE SPEED. OVERSPEEDING THE ENGINE ABOVE THE FACTORY HIGH SPEED SETTING CAN BE DANGEROUS. IF YOU THINK THE ENGINE-GOVERNED HIGH SPEED NEEDS ADJUSTING, CONTACT YOUR NEAREST AUTHORIZED SERVICE CENTER/DEPARTMENT, WHICH HAS PROPER EQUIPMENT AND EXPERIENCE TO MAKE ANY NECESSARY ADJUSTMENTS.

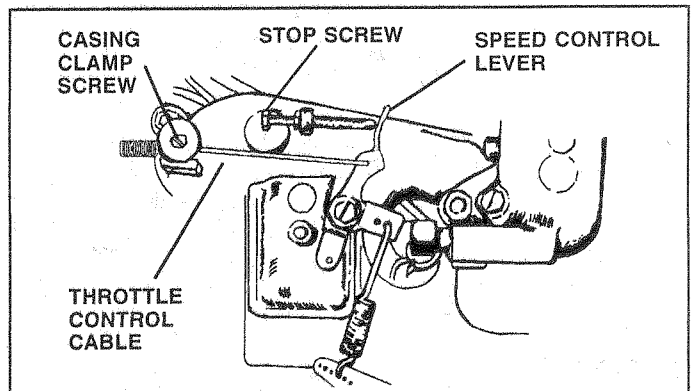

FIG. 38

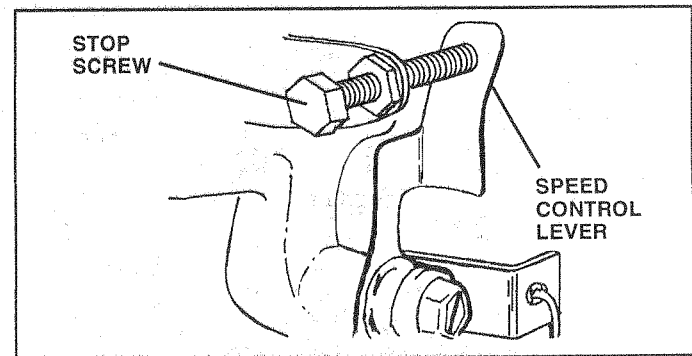

FIG. 39

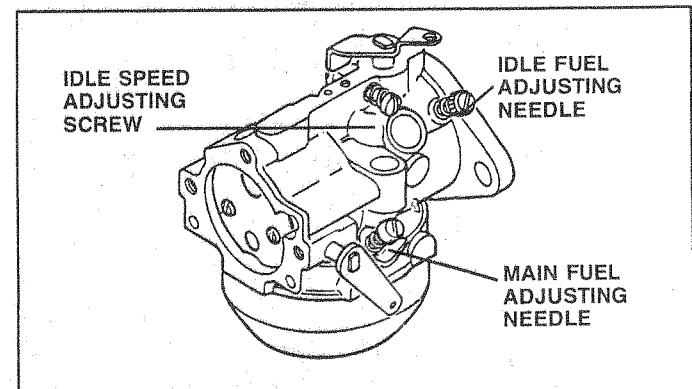

FIG. 40

STORAGE

Immediately prepare your tractor for storage at the end of the season or if the tractor will not be used for 30 days or more.



CAUTION: Never store the tractor with gasoline in the tank inside a building where fumes may reach an open flame or spark. Allow the engine to cool before storing in any enclosure.

TRACTOR

Remove mower from tractor for winter storage. When mower is to be stored for a period of time, clean it thoroughly, remove all dirt, grease, leaves, etc. Store in a clean, dry area.

- Clean entire tractor (See "CLEANING" in the Customer Responsibilities section of this manual).
- Inspect and replace belts, if necessary (See belt replacement instructions in the Service and Adjustments section of this manual).
- Lubricate as shown in the Customer Responsibilities section of this manual.
- Be sure that all nuts, bolts and screws are securely fastened. Inspect moving parts for damage, breakage and wear. Replace if necessary.
- Touch up all rusted or chipped paint surfaces; sand lightly before painting.

BATTERY

- Fully charge the battery for storage.
- After a period of time in storage, battery may require recharging.
- To help prevent corrosion and power leakage during long periods of storage, battery cables should be disconnected and battery cleaned thoroughly (see "TO CLEAN BATTERY AND TERMINALS" in the Customer Responsibilities section of this manual).
- After cleaning, leave cables disconnected and place cables where they cannot come in contact with battery terminals.
- Be sure battery drain tube is securely attached.
- If battery is removed from tractor for storage, do not store battery directly on concrete or damp surfaces.

ENGINE

FUEL SYSTEM

IMPORTANT: IT IS IMPORTANT TO PREVENT GUM DEPOSITS FROM FORMING IN ESSENTIAL FUEL SYSTEM PARTS SUCH AS CARBURETOR, FUEL FILTER, FUEL HOSE, OR TANK DURING STORAGE. ALSO, EXPERIENCE INDICATES THAT ALCOHOL BLENDED FUELS (CALLED GASOHOL OR USING ETHANOL OR METHANOL) CAN ATTRACT MOISTURE WHICH LEADS TO SEPARATION AND FORMATION OF ACIDS DURING STORAGE. ACIDIC GAS CAN DAMAGE THE FUEL SYSTEM OF AN ENGINE WHILE IN STORAGE.

- Drain the fuel tank.
- Start the engine and let it run until the fuel lines and carburetor are empty.
- Never use engine or carburetor cleaner products in the fuel tank or permanent damage may occur.
- Use fresh fuel next season.

NOTE: Fuel stabilizer is an acceptable alternative in minimizing the formation of fuel gum deposits during storage. Add stabilizer to gasoline in fuel tank or storage container. Always follow the mix ratio found on stabilizer container. Run engine at least 10 minutes after adding stabilizer to allow the stabilizer to reach the carburetor. Do not drain the gas tank and carburetor if using fuel stabilizer.

ENGINE OIL

Drain oil (with engine warm) and replace with clean engine oil. (See "ENGINE" in the Customer Responsibilities section of this manual).

CYLINDERS

- Remove spark plug(s).
- Pour one ounce of oil through spark plug hole(s) into cylinder(s).
- Turn ignition key to "START" position for a few seconds to distribute oil.
- Replace with new spark plug(s).

OTHER

- Do not store gasoline from one season to another.
- Replace your gasoline can if your can starts to rust. Rust and/or dirt in your gasoline will cause problems.
- If possible, store your tractor indoors and cover it to give protection from dust and dirt.
- Cover your tractor with a suitable protective cover that does not retain moisture. Do not use plastic. Plastic cannot breathe which allows condensation to form and will cause your tractor to rust.

IMPORTANT: NEVER COVER TRACTOR WHILE ENGINE AND EXHAUST ARE STILL WARM.

SERVICE NOTES

TROUBLESHOOTING POINTS

PROBLEM	CAUSE	CORRECTION
Will not start	<ol style="list-style-type: none"> 1. Out of fuel. 2. Engine not "CHOKED" properly. 3. Engine flooded. 4. Bad spark plug. 5. Dirty air filter. 6. Dirty fuel filter. 7. Water in fuel. 8. Loose or damaged wiring. 9. Carburetor out of adjustment. 10. Engine valves out of adjustment. 	<ol style="list-style-type: none"> 1. Fill fuel tank. 2. See "TO START ENGINE" in Operation section. 3. Wait several minutes before attempting to start. 4. Replace spark plug. 5. Clean/replace air filter. 6. Replace fuel filter. 7. Drain fuel tank and carburetor, refill tank with fresh gasoline and replace fuel filter. 8. Check all wiring. 9. Contact an authorized service center/department. 10. Contact an authorized service center/department.
Hard to start	<ol style="list-style-type: none"> 1. Dirty air filter. 2. Bad spark plug. 3. Weak or dead battery. 4. Dirty fuel filter. 5. Stale or dirty fuel. 6. Loose or damaged wiring. 7. Carburetor out of adjustment. 8. Engine valves out of adjustment. 	<ol style="list-style-type: none"> 1. Clean/replace air filter. 2. Replace spark plug. 3. Recharge or replace battery. 4. Replace fuel filter. 5. Drain fuel tank and refill with fresh gasoline. 6. Check all wiring. 7. Contact an authorized service center/department. 8. Contact an authorized service center/department.
Engine will not turn over	<ol style="list-style-type: none"> 1. Clutch/brake pedal not depressed. 2. Attachment clutch is engaged. 3. Weak or dead battery. 4. Blown fuse. 5. Corroded battery terminals. 6. Loose or damaged wiring. 7. Faulty ignition switch. 8. Faulty solenoid or starter. 9. Faulty operator presence switch(es). 	<ol style="list-style-type: none"> 1. Depress clutch/brake pedal. 2. Disengage attachment clutch. 3. Recharge or replace battery. 4. Replace fuse. 5. Clean battery terminals. 6. Check all wiring. 7. Check/replace ignition switch. 8. Check/replace solenoid or starter. 9. Contact an authorized service center/department.
Engine clicks but will not start	<ol style="list-style-type: none"> 1. Weak or dead battery. 2. Corroded battery terminals. 3. Loose or damaged wiring. 4. Faulty solenoid or starter. 	<ol style="list-style-type: none"> 1. Recharge or replace battery. 2. Clean battery terminals. 3. Check all wiring. 4. Check/replace solenoid or starter.
Loss of power	<ol style="list-style-type: none"> 1. Cutting too much grass/too fast. 2. Throttle in "CHOKE" position. 3. Build-up of grass, leaves and trash under mower. 4. Dirty air filter. 5. Low oil level/dirty oil. 6. Faulty spark plug. 7. Dirty fuel filter. 8. Stale or dirty fuel. 9. Water in fuel. 10. Spark plug wire loose. 11. Dirty engine air screen/fins. 12. Dirty/clogged muffler. 13. Loose or damaged wiring. 14. Carburetor out of adjustment. 15. Engine valves out of adjustment. 	<ol style="list-style-type: none"> 1. Set in "Higher Cut" position/reduce speed. 2. Adjust throttle control. 3. Clean underside of mower housing. 4. Clean/replace air filter. 5. Check oil level/change oil. 6. Clean and regap or change spark plug. 7. Replace fuel filter. 8. Drain fuel tank and refill with fresh gasoline. 9. Drain fuel tank and carburetor, refill tank with fresh gasoline and replace fuel filter. 10. Connect and tighten spark plug wire. 11. Clean engine air screen/fins. 12. Clean/replace muffler. 13. Check all wiring. 14. Contact an authorized service center/department. 15. Contact an authorized service center/department.
Excessive vibration	<ol style="list-style-type: none"> 1. Worn, bent or loose blade. 2. Bent blade mandrel. 3. Loose/damaged part(s). 	<ol style="list-style-type: none"> 1. Replace blade. Tighten blade bolt. 2. Replace blade mandrel. 3. Tighten loose part(s). Replace damaged parts.

TROUBLESHOOTING POINTS

PROBLEM	CAUSE	CORRECTION
Engine continues to run when operator leaves seat with attachment clutch engaged	<ol style="list-style-type: none"> 1. Faulty operator-safety presence control system. 	<ol style="list-style-type: none"> 1. Check wiring, switches and connections. If not corrected, contact an authorized service center/ department.
Poor cut - uneven	<ol style="list-style-type: none"> 1. Worn, bent or loose blade. 2. Mower deck not level. 3. Buildup of grass, leaves, and trash under mower. 4. Bent blade mandrel. 5. Clogged mower deck vent holes from buildup of grass, leaves, and trash around mandrels. 	<ol style="list-style-type: none"> 1. Replace blade. Tighten blade bolt. 2. Level mower deck. 3. Clean underside of mower housing. 4. Replace blade mandrel. 5. Clean around mandrels to open vent holes.
Mower blades will not rotate	<ol style="list-style-type: none"> 1. Obstruction in clutch mechanism. 2. Worn/damaged mower drive belt. 3. Frozen idler pulley. 4. Frozen blade mandrel. 	<ol style="list-style-type: none"> 1. Remove obstruction. 2. Replace mower drive belt. 3. Replace idler pulley. 4. Replace blade mandrel.
Poor grass discharge	<ol style="list-style-type: none"> 1. Engine speed too slow. 2. Travel speed too fast. 3. Wet grass. 4. Mower deck not level. 5. Low/uneven tire air pressure. 6. Worn, bent or loose blade. 7. Buildup of grass, leaves and trash under mower. 8. Mower drive belt worn. 9. Blades improperly installed. 10. Improper blades used. 11. Clogged mower deck vent holes from buildup of grass, leaves, and trash around mandrels. 	<ol style="list-style-type: none"> 1. Place throttle control in "FAST" position. 2. Shift to slower speed. 3. Allow grass to dry before mowing. 4. Level mower deck. 5. Check tires for proper air pressure. 6. Replace/sharpen blade. Tighten blade bolt. 7. Clean underside of mower housing. 8. Replace mower drive belt. 9. Reinstall blades sharp edge down. 10. Replace with blades listed in this manual. 11. Clean around mandrels to open vent holes.
Headlight(s) not working (if so equipped)	<ol style="list-style-type: none"> 1. Switch is "OFF". 2. Bulb(s) burned out. 3. Faulty light switch. 4. Loose or damaged wiring. 5. Blown fuse. 	<ol style="list-style-type: none"> 1. Turn switch "ON". 2. Replace bulb(s). 3. Check/replace light switch. 4. Check wiring and connections. 5. Replace fuse.
Battery will not charge	<ol style="list-style-type: none"> 1. Bad battery cell(s). 2. Poor cable connections. 3. Faulty regulator (if so equipped). 4. Faulty alternator. 	<ol style="list-style-type: none"> 1. Replace battery. 2. Check/clean all connections. 3. Replace regulator. 4. Replace alternator.
Engine "backfires" when turning engine "OFF"	<ol style="list-style-type: none"> 1. Engine throttle control not set at "SLOW" position for 30 seconds before stopping engine. 	<ol style="list-style-type: none"> 1. Move throttle control to "SLOW" position and allow to idle for 30 seconds before stopping engine.

18 HP 44" TRACTOR - MODEL NUMBER 917.257720

SCHEMATIC

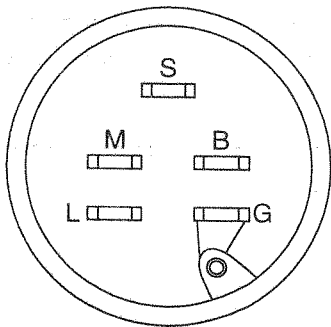
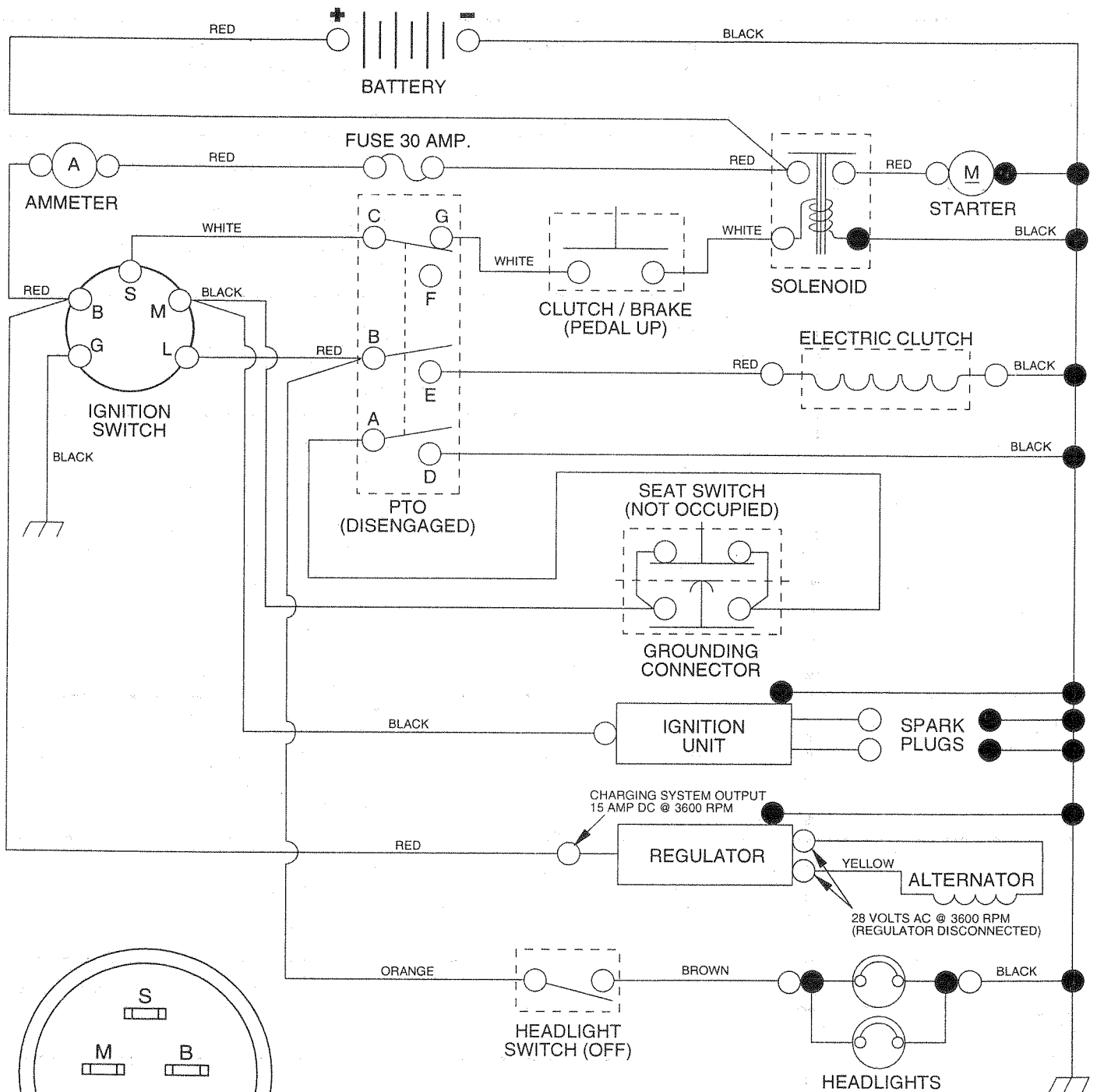

IGNITION SWITCH

POSITION	CIRCUIT
OFF	M + G
ON	B + L
START	B + S + L

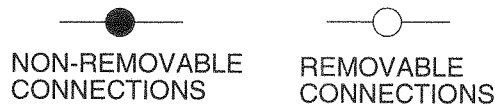

WIRING INSULATED CLIPS
NOTE: IF WIRING INSULATED CLIPS WERE REMOVED FOR SERVICING OF UNIT, THEY SHOULD BE REPLACED TO PROPERLY SECURE YOUR WIRING

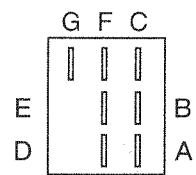

PTO SWITCH

POSITION	CIRCUIT
OFF	C + G
ON	C + F, B + E, A + D

REPAIR PARTS

18 HP 44" TRACTOR - - MODEL NUMBER 917.257720

DECALS

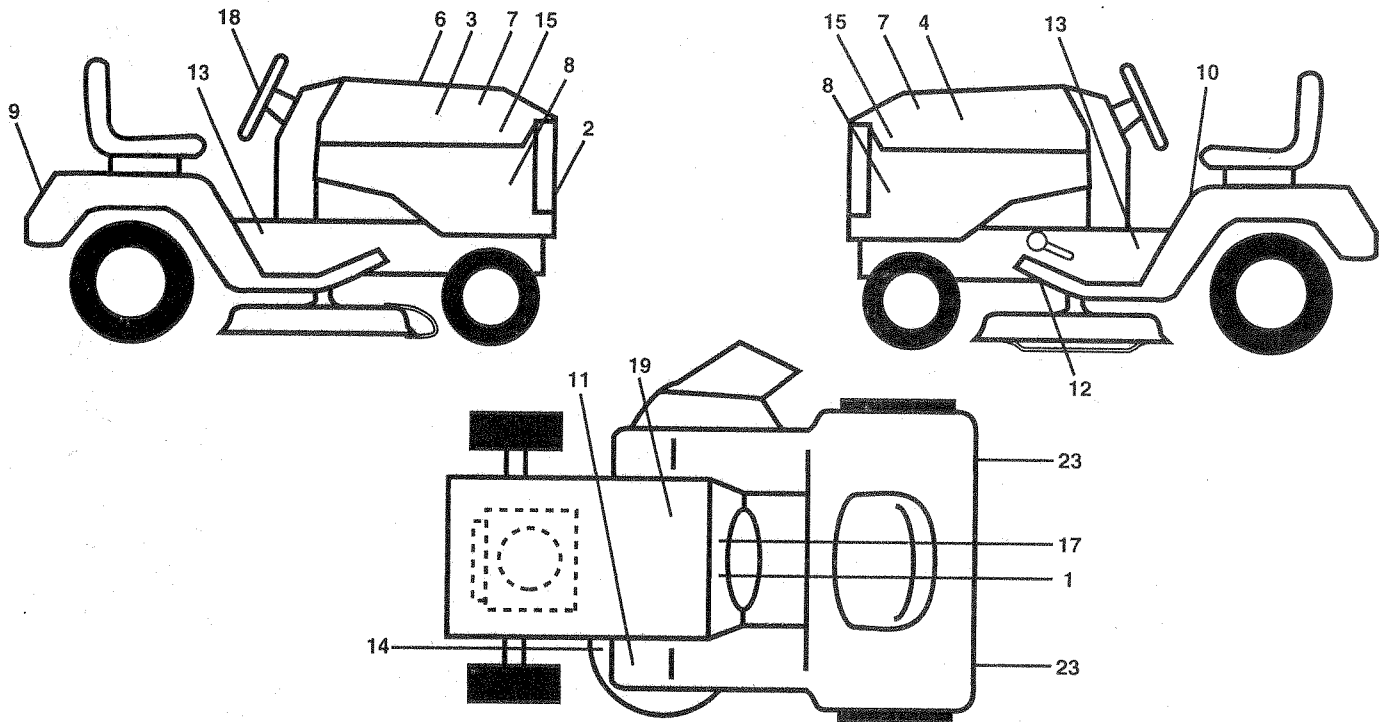

KEY PART NO. NO.

DESCRIPTION

1	138955	Decal, Operating Instruction
2	142254	Decal, Grill GT 6000 USA Black
3	138042	Decal, Hood, Craftsman, RH
4	138043	Decal, Hood, Craftsman, LH
6	133644	Decal, Maintenance
7	138048	Decal, Side Panel
8	142243	Decal, Side Panel
9	128314	Decal, Fender, Craftsman
10	137537	Decal, Caution
11	4900J	Decal, Clutch/Brake
12	138435	Decal, V-Belt Drive Schematic

KEY PART NO. NO.

DESCRIPTION

13	105567X	Decal, Chassis, 6 Speed/44"
14	139346	Decal, V-Belt Schematic
15	142242	Decal Hood Insert Hd GT
17	138834	Decal, Dash
18	132266	Decal, Insert Strg
19	138047	Decal, Battery
23	106202X	Reflector, Taillight
--	138311	Decal, Handle Lft Height Adjust (Lift Handle)
--	140330	Manual, Owner's (Eng)
--	140331	Manual, Owner's (Span)

WHEELS & TIRES

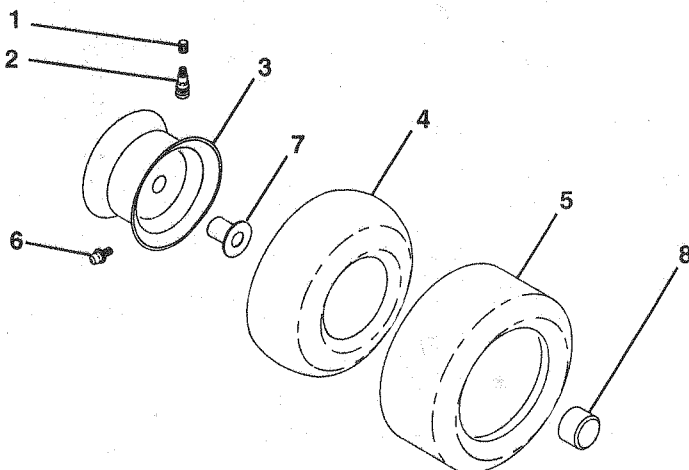

KEY PART NO. NO.

DESCRIPTION

1	59192	Cap, Valve, Tire
2	65139	Stem, Valve
3	106228X427	Rim Assembly, Front
	106277X427	Rim Assembly, Rear
4	8134H	Tube, Front (Service Item Only)
	7154J	Tube, Rear (Service Item Only)
5	106230X	Tire, Front
	105588X	Tire, Rear
6	278H	Fitting, Grease (Front Wheel Only)
	6856M	Fitting, Grease
7	9040H	Bearing, Flange (Front Wheel Only)
8	104757X	Cap, Axle (Front Wheel Only)
	136327	Cover, Axle (Rear Wheel Only)

NOTE: All component dimensions given in U.S. inches
1 inch = 25.4 mm

REPAIR PARTS

18 HP 44" TRACTOR - MODEL NUMBER 917.257720

ELECTRICAL

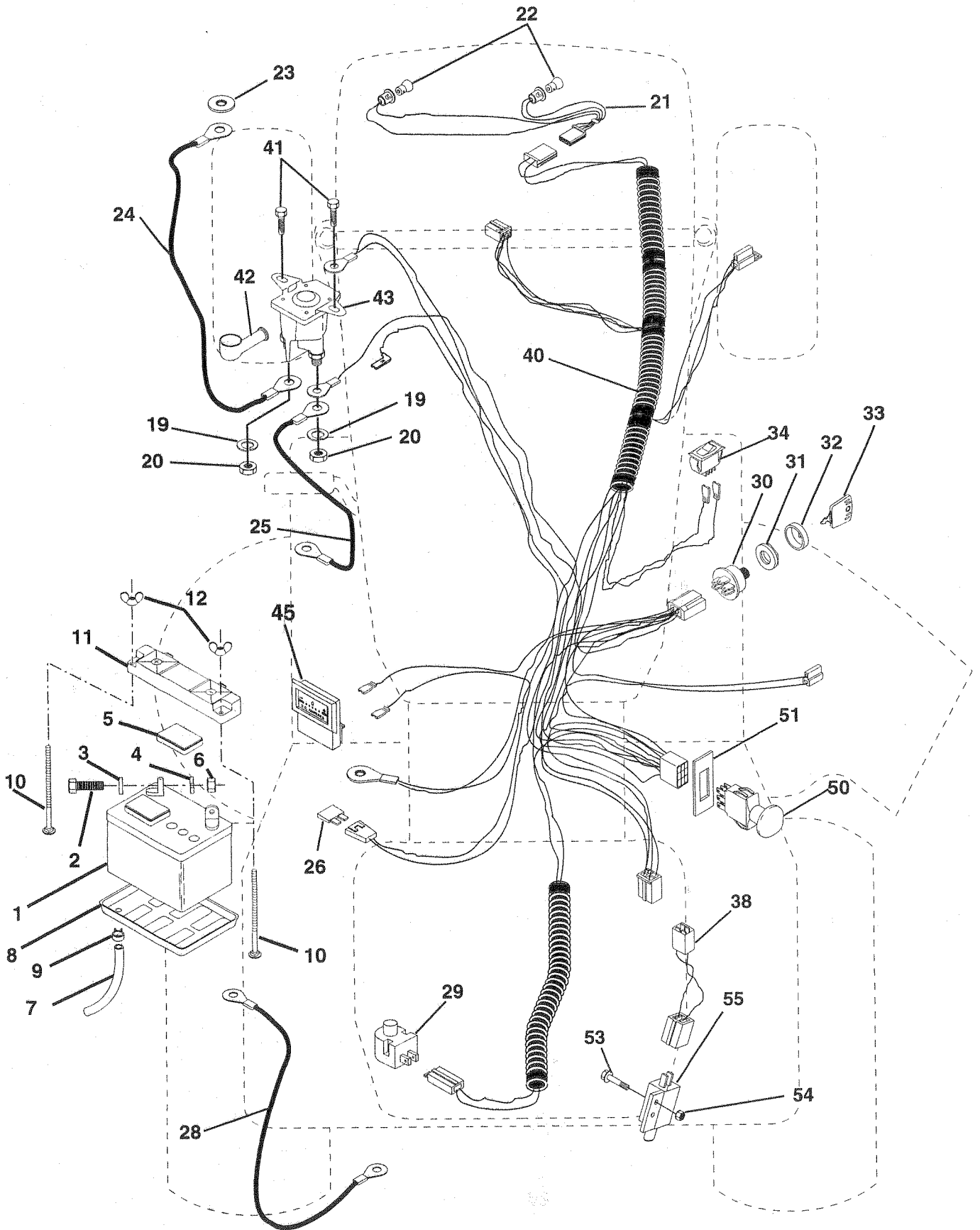

REPAIR PARTS

18 HP 44" TRACTOR - MODEL NUMBER 917.257720

ELECTRICAL

KEY NO.	PART NO.	DESCRIPTION
1	121537X	Battery
2	74760412	Bolt, Hex 1/4-20 x 3/4
3	STD551025	Washer 9/32 x 5/8 x 16 Ga.
4	STD551125	Washer, Lock 1/4
5	121264X	Caps, Battery
6	STD541025	Nut, Hex 1/4-20
7	7697J	Tube, Drain
8	7603J	Tray, Battery
9	109596X	Clamp, Hose
10	72240460	Bolt, Carriage 1/4-20 x 7-1/2
11	102476X	Guard, Terminal
12	123198X	Nut, Wing 1/4-20
19	10090400	Washer, Lock 1/4
20	73350400	Nut, Hex Jam 1/4-20
21	127441X	Harness, Light Socket
22	4152J	Bulb, Headlight
23	11150400	Washer, Lock, Int. Tooth
24	4799J	Cable Battery
25	4799J	Cable Battery
26	108824X	Fuse
28	121080X	Cable, Ground
29	121305X	Switch, Plunger
30	140399	Switch, Ignition
31	140400	Nut, Ignition
32	141226	Cover, Switch Key
33	140403	Key, Ignition
34	110712X	Switch, Light
38	140660	Harness Adapter
40	140428	Harness, Ignition
41	17720408	Screw, Hex Washer Head, Thread Cutting 1/4-20 x 1/2
42	131563	Cover, Terminal
43	138406	Solenoid
45	122822X	Ammeter
50	140404	Switch, P.T.O.
51	140405	Ring Retainer PTO
53	71031008	Screw, Hex Washer Head #10-32x1/2
54	73951000	Nut, Keps #10-32
55	104445X	Switch, Intlk Cl Grd Gry 2 Term

NOTE: All component dimensions given in U.S. inches
1 inch = 25.4 mm

*138406 (2)
Subs.
10994040*

REPAIR PARTS

18 HP 44" TRACTOR - MODEL NUMBER 917.257720

CHASSIS AND ENCLOSURES

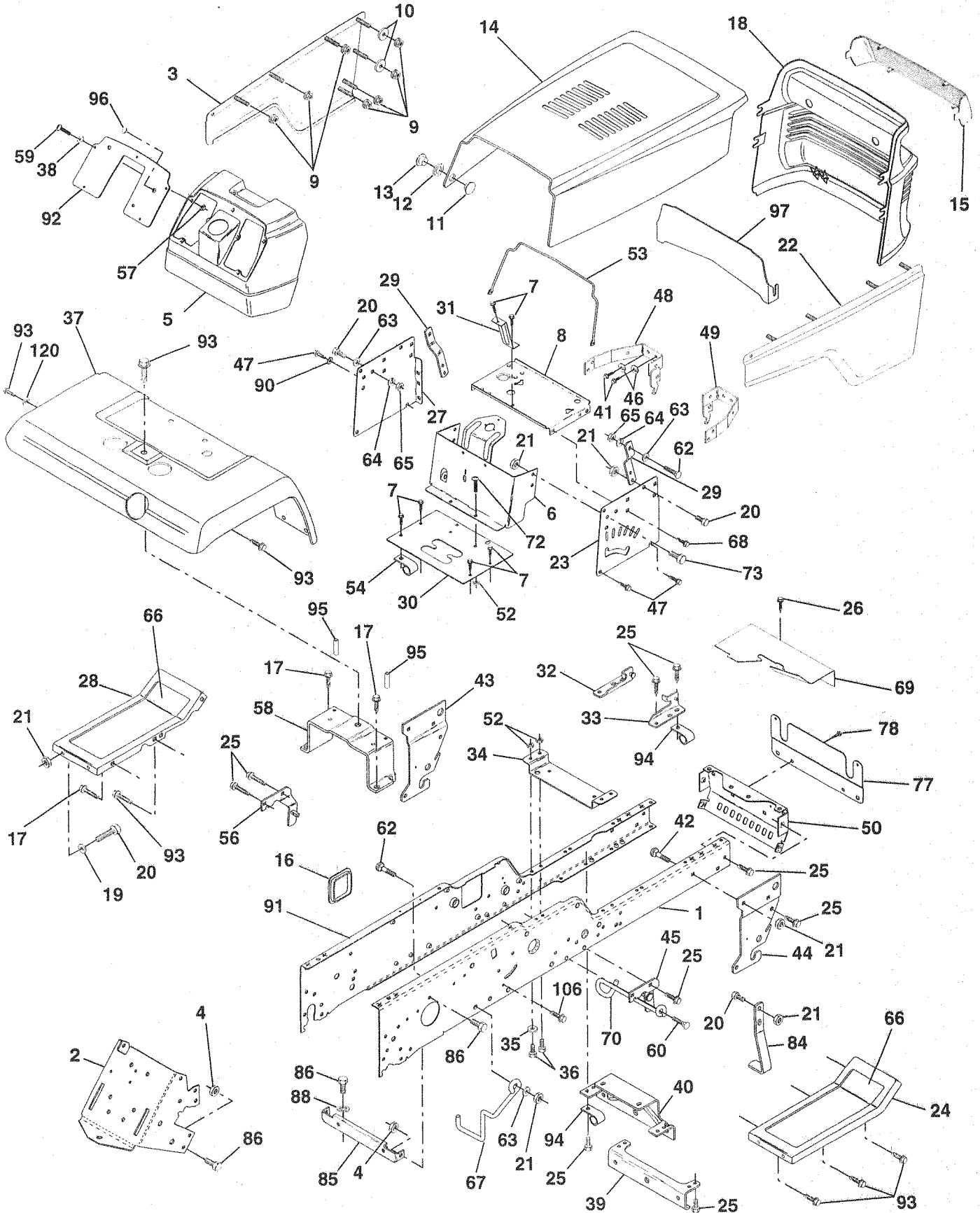

REPAIR PARTS

18 HP 44" TRACTOR - MODEL NUMBER 917.257720

CHASSIS AND ENCLOSURES

KEY PART NO.	NO.	DESCRIPTION	KEY PART NO.	NO.	DESCRIPTION
1	140505	Rail, Frame RH	44	136940	Bracket, Spnsn Front Rh
2	140506	Drawbar, Gt	45	138460	Bracket Asm., Susp Chassis Rh
3	136671X459	Panel Asm., Side LH	46	10040400	Washer, Lock Hvy Helical 1/4
4	73800700	Nut, Lock Hex 7/16 Unc	47	17490608	Screw Thdrol. 3/8-16 x 1/2
5	136696	Dash, Plastic Black	48	136814	Bracket Asm., Pivot Hood Lh
6	139420	Dash Asm., Lower	49	136813	Bracket Asm., Pivot Hood Rh
7	17720408	Screw, Thd Cut 1/4-20 x 1/2	50	136575	Bracket, Chassis Front
8	137563	Support, Battery	51	72140506	Bolt, Carriage 5/16-18 x 3/4
9	108067X	Nut, Pal	52	73800500	Locknut, Hex W/Ins 5/16-18 Unc
10	19092016	Washer 9/32 x 1-1/4 x 16 Ga.	53	137304	Rod, Support Hood
11	137270	Rivet, Ratchet Male	54	126470X	Clip, Insulated
12	137269	Washer, Nylon	56	138461	Bracket Asm., Susp Chassis Lh
13	137271	Rivet, Ratchet Female	57	73510400	Nut, Keps Hex 1/4-20
14	136673X459	Hood Asm., Pnt	58	137113	Bracket Asm., Fender
15	136374	Lens, Bar Clear	59	74180412	Screw, Mach Cr 1/4-20 x 3/4
16	121794X	Cover, Access	60	17490620	Screw Thdrol. 3/8-16 x 1-1/4
17	17490612	Screw, Thdrol 3/8-16 x 3/4	62	72110608	Bolt, Carriage 3/8-16 x 1 Gr. 5
18	136373X428	Grille	63	19131614	Washer 13/32 x 1 x 14 Ga.
19	19131312	Washer 13/32 x 13/16 x 12 Ga.	64	10040600	Washer, Lock Hvy Hlcl Spr 3/8
20	74760616	Bolt, Fin Hex 3/8-16 x 1	65	73220600	Nut, Fin Hex 3/8-16 Unc
21	73800600	Nut, Lock Hex W/Wsh 3/8-16 Unc	66	105466X	Pad, Footrest
22	136670X459	Panel Asm., Side RH	67	137157	Guide, Belt T/A
23	121045X	Panel, Dash Side RH	68	17490508	Screw Thdrol. 5/16-18 x 1/2
24	105464X459	Footrest, RH	69	139212	Shield, Heat
25	17490612	Screw, Thdrol 3/8-16 x 3/4	70	137159	Guide, Belt Mid Span
26	17490512	Screw, Thdrol 5/16-18 x 3/4	72	74180512	Screw, Mach Trhd 5/16-18 x 3/4
27	121046X	Panel, Dash Side LH	73	74780616	Bolt, Fin Hex 3/8-16 x 1 Gr. 5
28	105465X459	Footrest, LH	77	137308	Shield, Front
29	138193	Bracket, Support Dash	78	17720408	Screw, Thd. Cut 1/4-20 x 1/2
30	137143X014	Saddle, Silkscr Vgt	84	138952	Stop, Over Center Mower
31	137556	Brace, Support Steering	85	120404X	Bracket, Support Transaxle
32	136742	Bracket Asm., Frame Pivot Lh	86	74760716	Bolt, Fin Hex 7/16-14 Unc x 1
33	136741	Bracket Asm., Frame Pivot Rh	88	10040700	Washer, Lock Hvy Hlcl Spr 7/16
34	136963	Bracket, Engine Support Rear	90	11050600	Washer, Lock External Tooth 3/8
35	19111116	Washer 11/32 x 11/16 x 16 Ga.	91	140504	Rail, Frame Lh
36	74780512	Bolt, Fin Hex 5/16-18 x 3/4	92	140941X013	Plate, Silkscreen Dash
37	121642X459	Fender, Pnt.	93	17490608	Screw, Thdrol 3/8-16 x 1/2
38	19091216	Washer 9/32 x 3/4 x 16 Ga.	94	100207K	Clip, Fuel Line
39	136961	Bracket, Axle Front	95	105531X	Push Nut, Nylon
40	136962	Bracket, Support Axle/Engine	96	8022J	Plug, Hole
41	74760408	Bolt, Fin Hex 1/4-20 Unc x 1/2	97	137373	Shield, Heat, Engine
42	72140608	Bolt, Carriage 3/8-16 x 1	106	17580520	Bolt 5/16-18 x 1-1/4
43	136939	Bracket, Spnsn Front Lh			

NOTE: All component dimensions given in U.S. inches
1 inch = 25.4 mm

REPAIR PARTS

18 HP 44" TRACTOR - MODEL NUMBER 917.257720

GROUND DRIVE

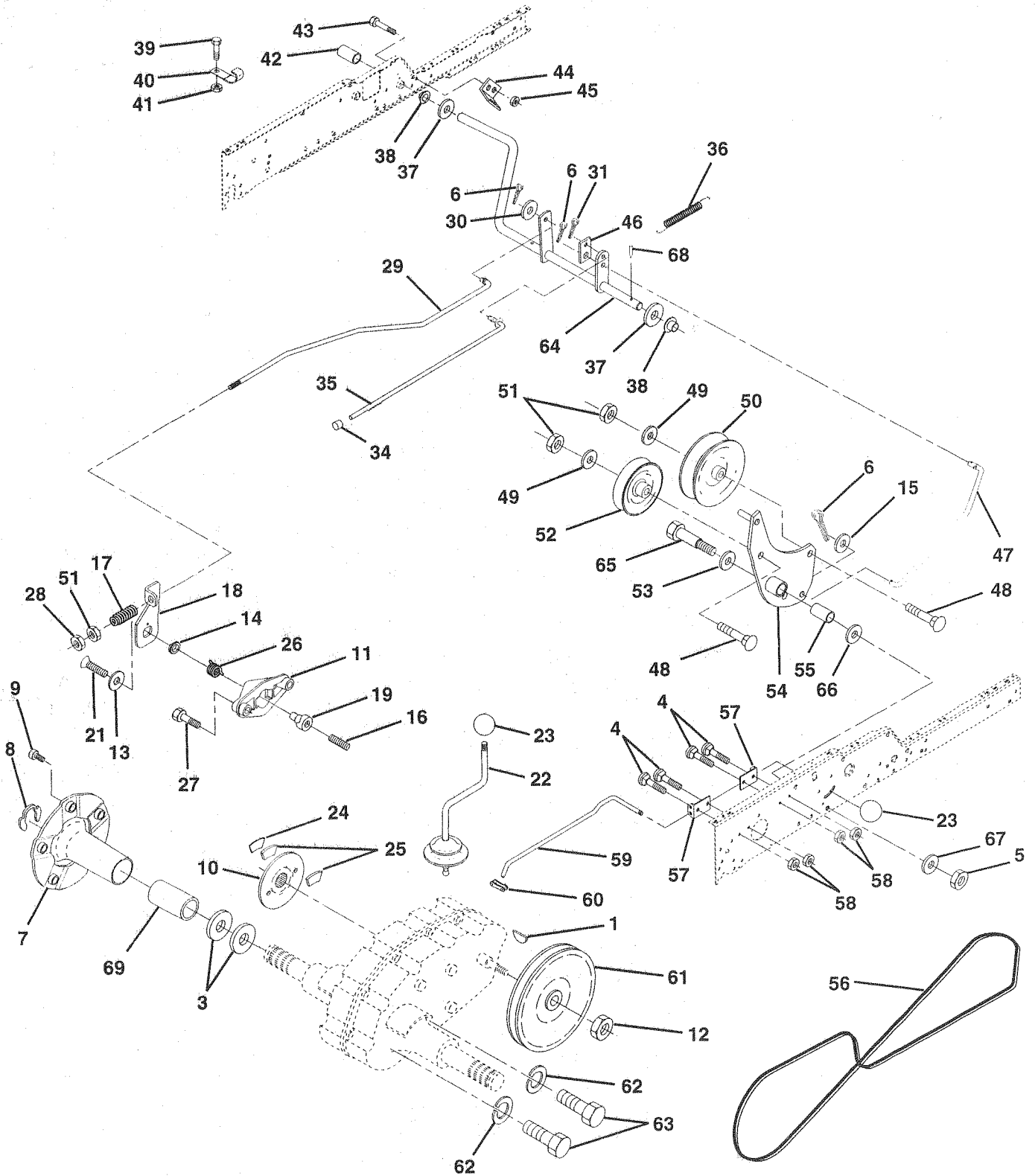

REPAIR PARTS

18 HP 44" TRACTOR - MODEL NUMBER 917.257720

GROUND DRIVE

KEY NO.	PART NO.	DESCRIPTION	KEY NO.	PART NO.	DESCRIPTION
1	9858M1	Key, Woodruff	38	110895X	Nyliner
3	7563R	Washer, Thrust, Axle	39	74321016	Screw, Fin. #10-24 x 1
5	73680600	Nut, Crownlock 3/8-16	40	5304J	Actuator, Interlock Switch
6	76020412	Pin, Cotter	41	73631000	Locknut #10-24
7	135758	Wheel, Hub Assembly	42	8883R	Cover, Pedal
8	12000034	Klip, Ring	43	74760412	Bolt, Hex 1/4-20 x 3/4
9	140080	Bolt, Hub	44	104601X	Bracket, Interlock
10	143046	Disc, Brake	45	73800400	Locknut w/Insert 1/4-20
11	136927	Yoke, Brake Disc	46	121358X	Retainer, Spring
12	9204H	Locknut 1/2-20	47	138228	Clutch Rod
13	139419	Washer, Special	48	72110614	Bolt, Carriage 3/8-16 x 1-3/4 Gr. 5
14	38901	Bushing	49	19131413	Washer 13/32 x 7/8 x 13 Ga.
15	19131316	Washer 13/32 x 13/16 x 16 Ga.	50	131494	Pulley, Idler, Flat
16	143012	Set, Screw 1/4-28 x 3/4	51	73800600	Locknut, Hex 3/8-16
17	126909X	Spring	52	139123	Pulley, Idler, Grooved
18	137104	Lever, Brake	53	207J	Washer, Hardened
19	136926	Cam, Brake Disc	54	138390	Clutch, Arm Assembly
20	72140506	Bolt, Carriage 5/18-18 x 3/4	55	105706X	Bearing, Idler
21	23260412	Screw, Flat Head 1/4-28 x 3/4	56	137153	V-Belt
22	633A109	Gearshift, Lever Assembly	57	105598X	Bracket, Shift Rod, Hi-Lo
23	106932X	Knob	58	73800500	Locknut, Hex, with Insert 5/16-19
24	136925	Support, Puck Brake	59	122253X	Shift Rod, Hi-Lo
25	136923	Puck, Brake Top	60	122268X	Spring Clip, Connecting Link
26	137552	Spring, Return	61	137524	Pulley, Transaxle
27	17490528	Screw, Hex Wsh Thd. 5/16-18 x 1-3/4	62	10040700	Washer, Lock 7/16
28	73350600	Nut, Hex Jam 3/8-16	63	74760720	Bolt, Fin Hex 7/16-14 x 1-1/4
29	137213	Brake, Rod	64	137649	Shaft, Clutch/Brake Pedal
30	19131614	Washer 13/32 x 1 x 14 Ga.	65	67609	Bolt, Shoulder
31	76020312	Pin, Cotter 3/32 x 3/4	66	140296	Washer, Hardened
34	124236X	Cap, Plunger	67	19131312	Washer, Flat
35	137648	Rod, Parking Brake	68	5142H	Pin, Roll
36	138364	Spring, Extension	69	136327	Hub, Cover
37	121749X	Washer 25/32 x 1-1/4 x 16 Ga.			

NOTE: All component dimensions given in U.S. inches
1 inch = 25.4 mm

REPAIR PARTS

18 HP 44" TRACTOR - MODEL NUMBER 917.257720

STEERING ASSEMBLY

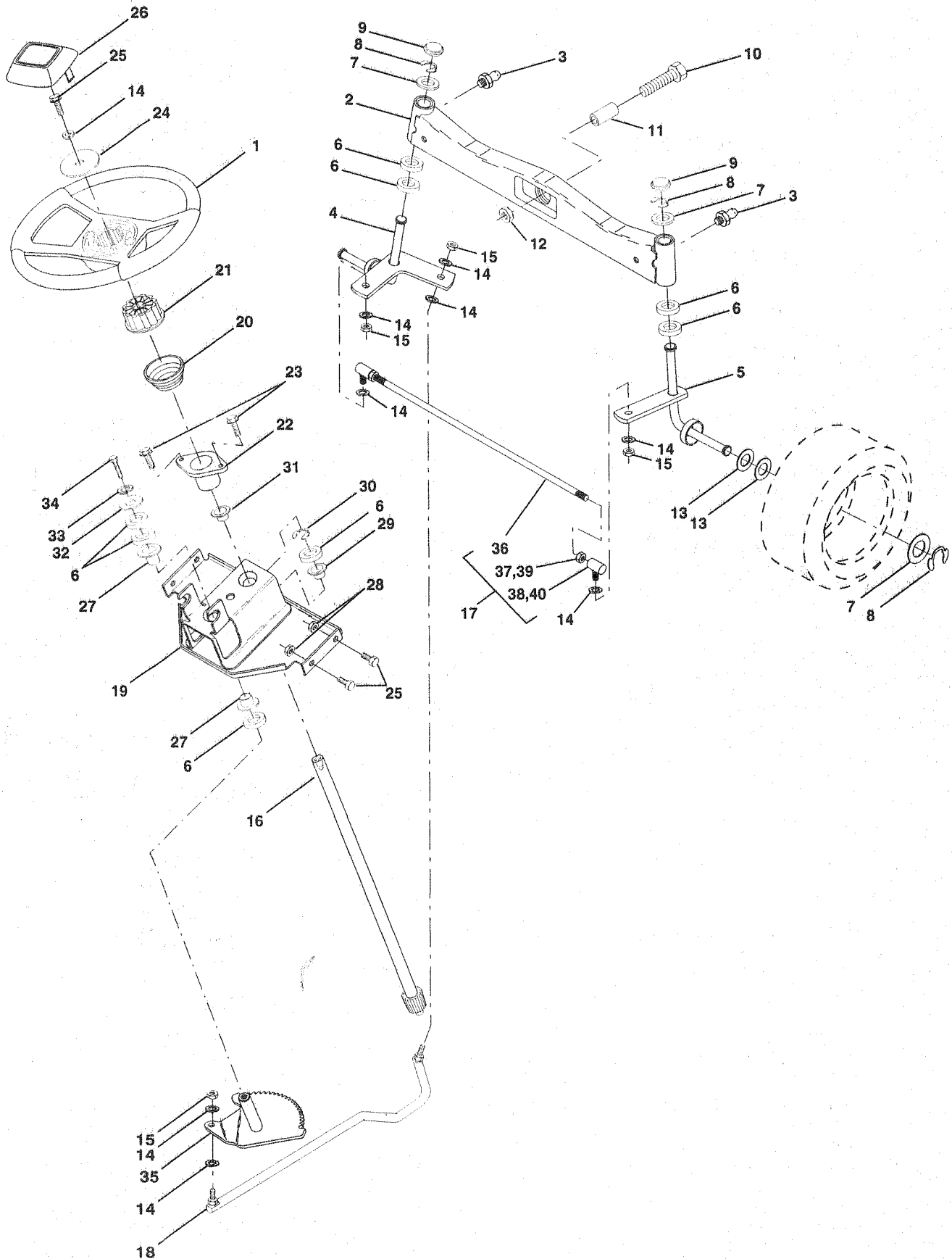

REPAIR PARTS

18 HP 44" TRACTOR - MODEL NUMBER 917.257720

STEERING ASSEMBLY

KEY NO.	PART NO.	DESCRIPTION
1	121472X	Wheel, Steering
2	137094	Axle Asm., Front
3	6855M	Fitting, Grease
4	136960	Spindle Asm, LH
5	136959	Spindle Asm., RH
6	6266H	Bearing, Race Thrust Harden
7	121748X	Washer 25/32 x 1-5/8 x 16 Ga.
8	12000029	Ring, Klip #T5304-75
9	121232X	Cap, Spindle
10	74781044	Bolt, Fin Hex 5/8-11 x 2-3/4
11	136518	Spacer, Brg. Axle Front
12	73901000	Nut, Lock Flange 5/8-11 Unc
13	121749X	Washer 25/32 x 1-1/4 x 16 Ga.
14	10040600	Washer, Lock Hvy Hlcl Spr 3/8
15	73610600	Nut, Fin Hex 3/8-24 Unf
16	102458X	Shaft Asm., Steering
17	137347	Rod Asm., Tie Ball J Ball Vgt (Inc. Key No. 36-40)
18	137155	Draglink, Ball Joint Solid Vgt
19	138053	Support Asm., Steering Vgt
20	139811	Column, Steering
21	100711L	Adapter, Wheel Steering
22	1554J	Bushing, Strg. Blk
23	17431008	Screw, Slftp #10-16 x 1/2 Ty-b
24	19133808	Washer 13/32 x 2-3/8 x 8 Ga.
25	74780616	Bolt, Fin Hex 3/8-16 x 1 Gr. 5
26	126805X	Cap, Wheel Steering
27	3366R	Bearing, Col. Strg.
28	73800600	Nut, Lock Hex W/Wsh 3/8-16 Unc
29	104239X	Bearing, Flange
30	12000034	Ring, Klip Truarc #5304-75
31	138136	Bushing, Nyliner Snap
32	19111610	Washer 11/32 x 1 x 10 Ga.
33	10040500	Washer, Lock Hvy Hlcl Spr 5/16
34	74760512	Bolt, Hex Hd 5/16-18 x 3/4
35	138059	Gear, Sector Steering
36	137156	Tie Rod
37	73360600	Jam Nut RH Thread
38	109850X	Joint Asm. Ball RH Thread
39	73700600	Jam Nut LH Thread
40	109851X	Joint Asm. Ball LH Thread

NOTE: All component dimensions given in U.S. inches
1 inch = 25.4 mm

REPAIR PARTS

18 HP 44" TRACTOR - MODEL NUMBER 917.257720

ENGINE

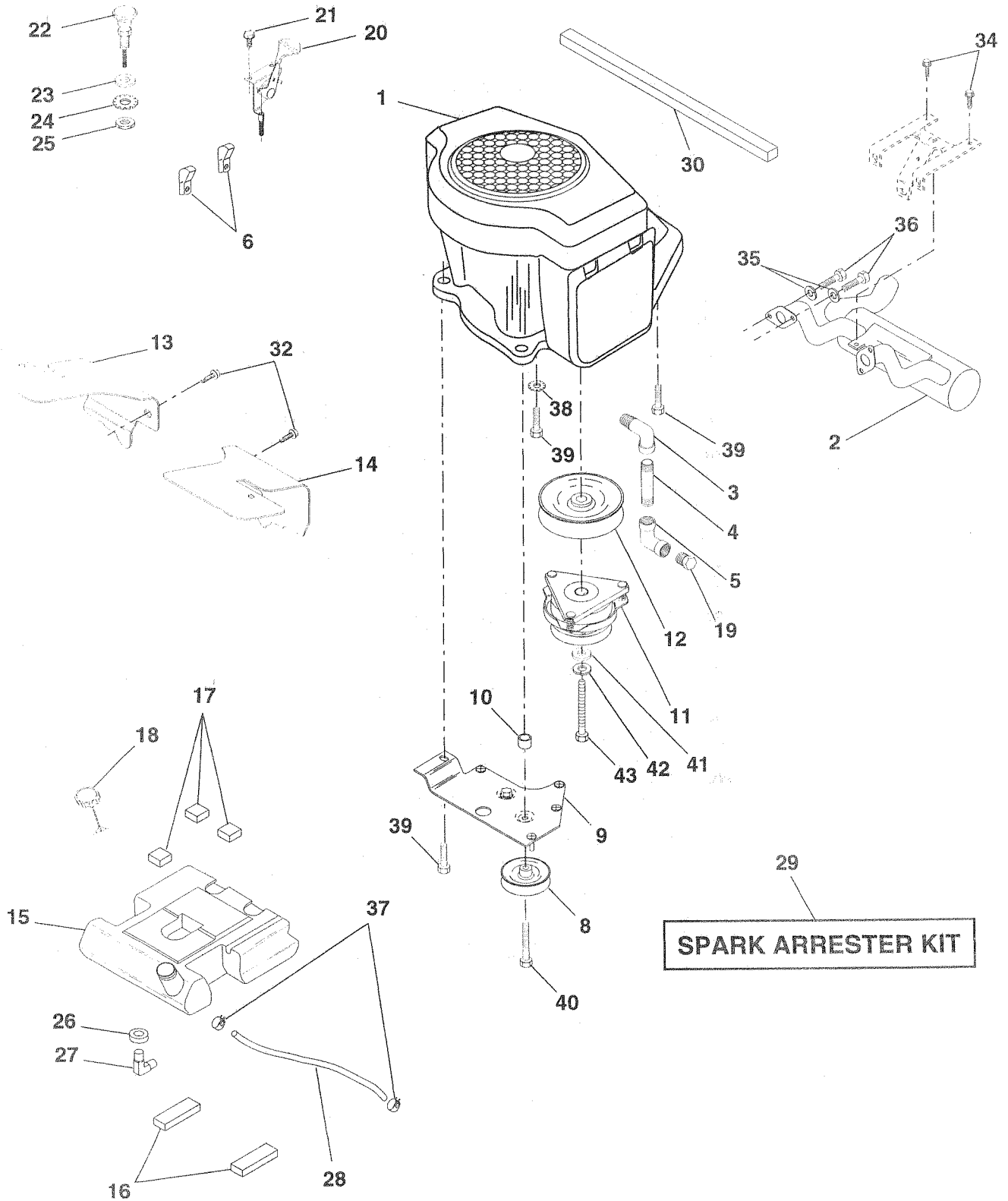

REPAIR PARTS

18 HP 44" TRACTOR - MODEL NUMBER 917.257720

ENGINE

KEY NO.	PART NO.	DESCRIPTION	KEY NO.	PART NO.	DESCRIPTION
1	141948	Engine Kohler 18 Mag Vt	22	138672	Control Choke
2	144110	Muffler Asm Kohler VGT (Inc. Key No. 34)	23	19132616	Washer 13/32 X 1 - 5/8 X 16 Ga
3	13240300	Elbow Street 3/8 NPT	24	11050600	Washer Ext Tooth 3/8
4	13280328	Nipple Pipe 3/8NPT X 3 - 1/2	25	73610600	Nut Fin Hex 3/8 - 24 UNF
5	13200300	Elbow STD 90 Degree 3/8 - 18 NPT	26	3645J	Bushing
6	138129	Clamp Tube Double Engine	27	139277	Stem Tank Fuel
8	121361X	Pulley V-Idler	28	7834R	Fuel Line
9	138559	Stop Keeper Asm VGT	29	132920	Spark Arrester Kit
10	105432X	Bushing	30	105037X	Strip Foam
11	137140	Clutch Electric	32	17490508	Screw Thdrol 5/16 - 18 X 1/2
12	136907	Pulley Engine VGT Elect Clutch	34	17720408	Screw Thd Cut 1.4 - 20 x 1/2
13	138486	Baffle Air LH Koh VGT	35	10040500	Washer Lock 5/16
14	138487	Baffle Air RH Koh VGT	36	74570512	Screw Hex 5/16 - 16 UNC X 3/4
15	127334X	Tank Fuel W/Sym Vented	37	123487X	Clamp Hose
16	109227X	Pad Spacer	38	11050600	Lockwasher Ext Tooth 3/8
17	106082X	Pad Spacer	39	17490624	Screw Thdrol 3/8 - 16 X 1 - 1/2 TT
18	123549X	Cap Asm Fuel W/Sym Vented	40	17490652	Screw Thdrol 3/8 - 16 X 3 - 1/4
19	13290300	Plug Oil Drain (Order From Engine Manufacturer)	41	126197X	Washer 1-1/2 OD X 15/32 ID X .250
20	133439	Control Throttle	42	10040700	Washer Lock 7/16
21	17720410	Screw Hex Thd Cut 1/4 - 20 X 5/8	43	71170768	Bolt Hex 7/16 - 20 X 4 - 1/4 Ga 5

NOTE: All component dimensions given in U.S. inches
1 inch = 25.4 mm

REPAIR PARTS

18 HP 44" TRACTOR - MODEL NUMBER 917.257720

SEAT ASSEMBLY

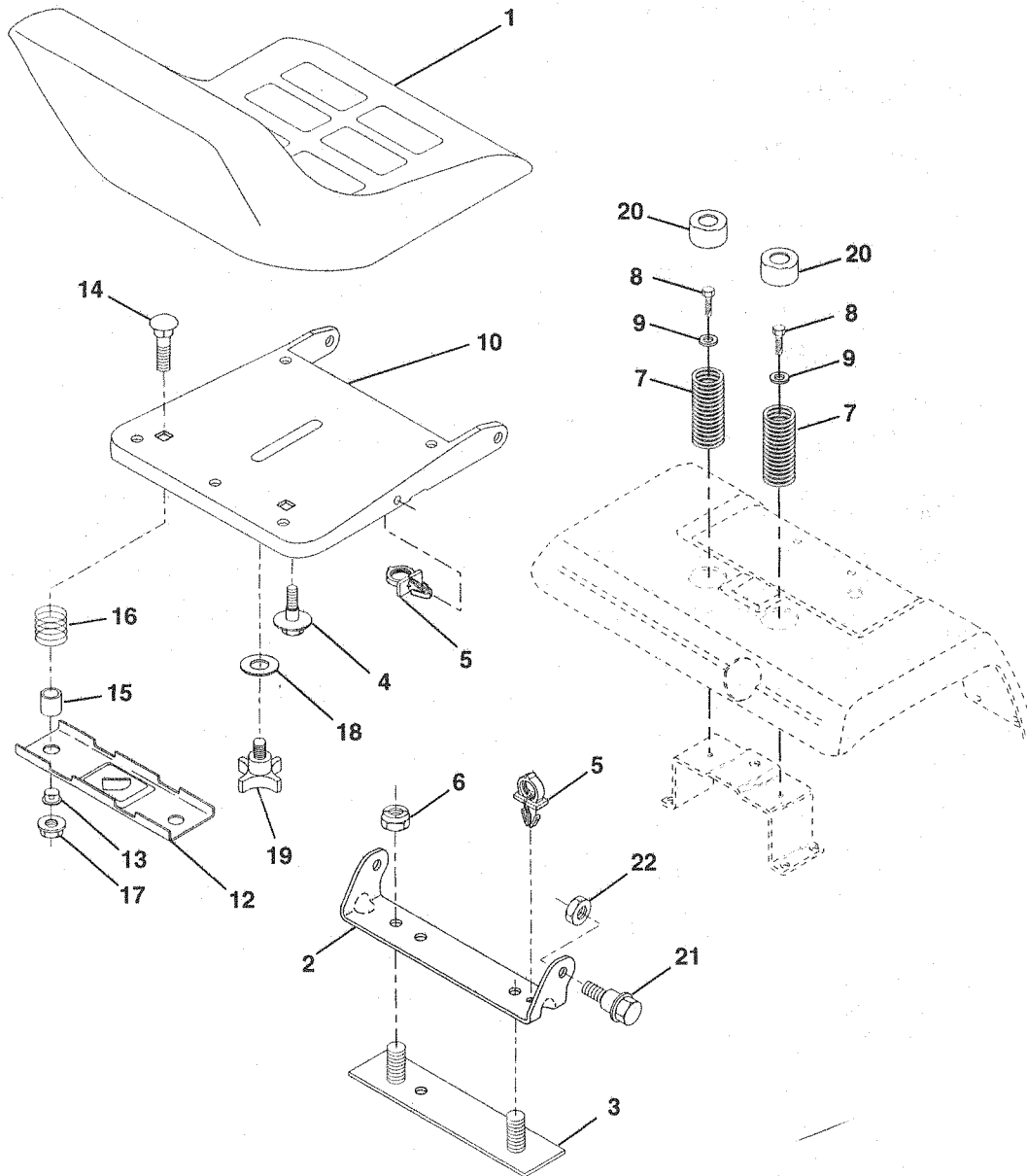

KEY PART
NO. NO.

KEY NO.	PART NO.	DESCRIPTION
1	127439	Seat
2	140551	Bracket, Pivot Seat
3	140675	Strap, Fender
4	127018X	Bolt, Shoulder 5/16-18 x .62
5	140407	Clip, Push In
6	73680600	Nut, Crownlock 3/8-16 Unc
7	124181X	Spring, Seat Cprsn
8	17490508	Screw, Thdrol 5/16-18 X 1/2
9	19131614	Washer 13/32 X 1 X 14 Ga.
10	140552	Pan, Seat
12	121246X	Bracket, Mounting Switch
13	121248X	Bushing, Snap

KEY PART
NO. NO.

KEY NO.	PART NO.	DESCRIPTION
14	72050411	Bolt, Carriage 1/4-20 X 1-3/8
15	121249X	Spacer, Split
16	123740X	Spring, Cprsn
17	123976X	Nut, Lock 1/4 Lge Flg Gr. 5
18	19171912	Washer 17/32 x 1-3/16 x 12 Ga.
19	120068X	Knob, Seat 1/2-13 Unc
20	124238X	Cap, Spring Seat
21	139888	Bolt, Shoulder 5/16-18
22	73680500	Nut, Crownlock 5/16-18 Unc

NOTE: All component dimensions given in U.S. inches
1 inch = 25.4 mm

REPAIR PARTS

18 HP 44" TRACTOR - MODEL NUMBER 917.257720

LIFT ASSEMBLY

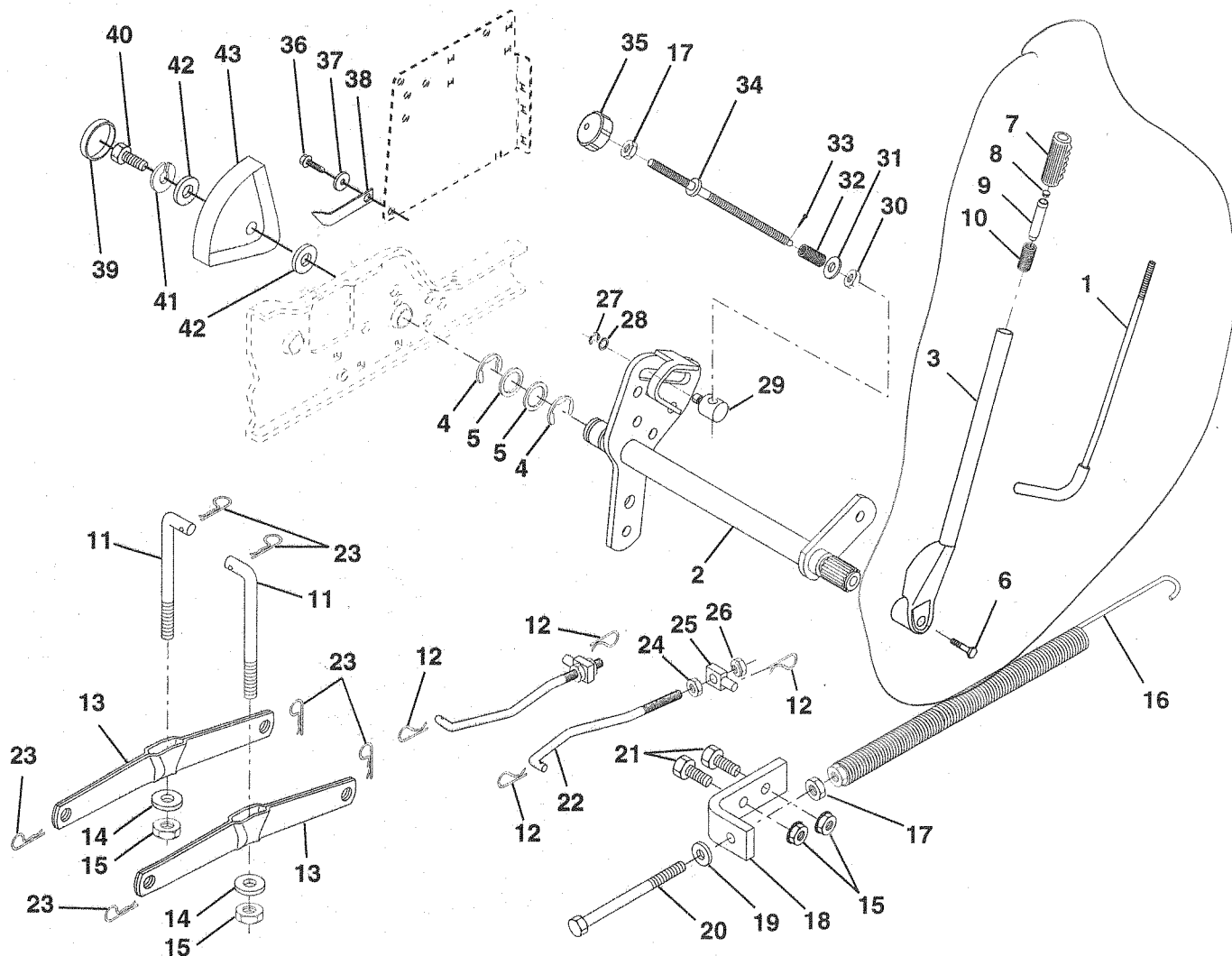

KEY NO.	PART NO.	DESCRIPTION
1	121006X	Rod Asm., Lever
2	137295	Shaft Asm., Lift Vgt
3	121002X	Lever Asm., Lift Rh
4	12000022	E-Ring Truarc #5133-87
5	19292016	Washer 29/32 x 1-1/4 x 16 Ga.
6	74780624	Bolt, Fin Hex 3/8-16 x 1-1/2
7	125631X	Grip, Handle Fluted
8	122365X	Button, Plunger
9	122364X	Plunger, Lever Lift
10	2876H	Spring 2-1/8"
11	138020	Link Lift
12	3146R	Retainer, Spring
13	139867	Arm, Suspension Vgt
14	140302	Bearing
15	73800600	Nut, Lock Hex W/Wsh 3/8-16 Unc
16	674A247	Spring Asm., Assist Lift
17	73350600	Nut, Hex Jam 3/8-16 Unc
18	5329J	Bracket, Spring Assist
19	19131316	Washer 13/32 x 13/16 x 16 Ga.
20	5328J	Bolt, Adjust Spring Assist
21	74760616	Bolt, Fin Hex 3/8-16 x 1
22	127218	Link, Front
23	4939M	Retainer, Spring

KEY NO.	PART NO.	DESCRIPTION
24	73350800	Nut, Jam Hex 1/2-13 Unc
25	130171	Trunnion
26	73800800	Nut, Lock W/Wsh 1/2-13 Unc
27	12000037	Ring, Klip #T5304-37
28	19151216	Washer 15/32 x 3/4 x 16 Ga.
29	110810X	Trunnion, Dp Stop Dbl Thds Plt
30	110807X	Nut, Special
31	19131016	Washer 13/32 x 5/8 x 16 Ga.
32	137150	Spring, Compression Inf Hgt
33	76020308	Pin, Cotter 3/32 x 1/2
34	137167	Rod, Adj Lift
35	138057	Knob, Inf 3/8-16 Unc
36	17490612	Screw, Thdrol 3/8-16 x 3/4
37	120529X	Washer, Nylon
38	123933X505	Pointer, Pnt Height Indicator
39	123935X	Plug, Hole
40	74780516	Bolt, Fin Hex 5/16-18 x 1
41	10040500	Washer, Lock Hvy Hlcl Spr 5/16
42	19112410	Washer 11/32 x 1-1/2 x 10 Ga.
43	123934X	Scale, Indicator Height

NOTE: All component dimensions given in U.S. inches
1 inch = 25.4 mm

REPAIR PARTS

18 HP 44" TRACTOR - MODEL NUMBER 917.257720

44" MOWER DECK

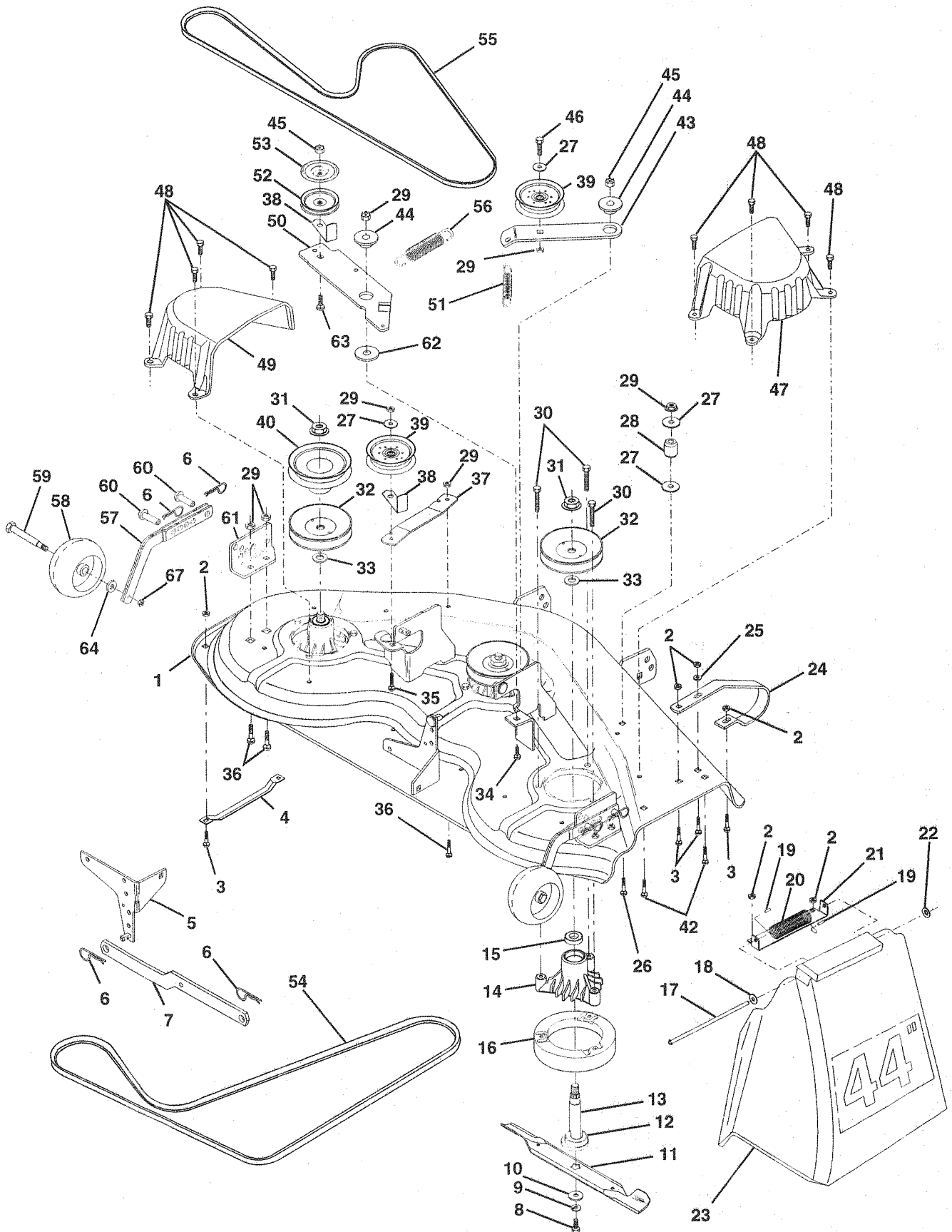

REPAIR PARTS

18 HP 44" TRACTOR - MODEL NUMBER 917.257720

44" MOWER DECK

144075 Comp Deck

KEY NO.	PART NO.	DESCRIPTION	KEY NO.	PART NO.	DESCRIPTION
1	136471	Deck Asm., Mower 44" Vented	33	129963	Washer, Spacer Mower Vented
2	73800500	Locknut, Hex W/Ins 5/16-18 Unc	34	72140610	Bolt, Carriage 3/8-16 x 1-1/4
3	72110506	Bolt, Carriage 5/16-18 x 3/4	35	72110616	Bolt, Carriage 3/8-16 x 2
4	7631J	Runner, Mower LH	36	72110608	Bolt, Carriage 3/8-16 x 1 Gr. 5
5	138457	Bracket Asm., Sway Bar	37	137166	Stiffener, Arm Idler
6	4939M	Retainer, Spring	38	137554	Keeper, Belt Idler
7	130832	Arm Suspension, Rear	39	131494	Pulley, Idler Flat
8	850857	Bolt 3/8-24 x 1.25 Gr. 8 Patched	40	136572	Pulley, Driven
9	10030600	Washer, Lock Hvy 3/8 Unplated	42	72140506	Bolt, Carriage 5/16-18 Unc x 3/4
10	129962	Washer, Hard Blade Mower Vented	43	136460	Arm, Idler Secondary
11	130652	Blade	44	122052X	Spacer, Retainer
12	129895	Bearing, Ball #6204 (Mandrel)	45	73680600	Nut, Crownlock 3/8-16 Unc
13	137553	Shaft Asm., W/Lower Brg (Includes Key No. 12)	46	74760628	Bolt, Fin Hex 3/8-16 Unc x 1-3/4
14	137152	Housing, Mandrel 44" Vent	47	137200	Cover, Mandrel RH
15	110485X	Bearing, Ball Mandrel	48	137729	Screw, Thd Roll 1/4-20 x 5/8
16	136929	Stripper, Mower Vented	49	136574	Cover, Mandrel LH
17	106735X	Rod, Hinge	50	137272	Arm, Idler Primary
18	19111016	Washer 11/32 x 5/8 x 16 Ga.	51	137273	Spring, Secondary
19	105304X	Cap, Sleeve	52	139245	Pulley, Idler V Groove
20	123713X	Spring, Torsion Deflector	53	137789	Shield, Idler
21	137607	Bracket, Deflector	54	131264	V-Belt, Mower Primary
22	110452X	Nut, Push	55	131290	V-Belt, Mower Secondary
23	109785X	Shield, Deflector Mower	56	138687	Spring, Primary
24	136321	Runner, RH	57	136577	Bar Asm., Wheel Gauge
25	19111216	Washer 11/32 x 3/4 x 16 Ga.	58	133957	Wheel, Gauge
26	72110614	Bolt, Carriage 3/8-16 x 1-3/4 Gr. 5	59	137644	Bolt, Shoulder
27	19131316	Washer 13/32 x 13/16 x 16 Ga.	60	139031	Pin, Clevis
28	132823	Spacer, Spring Stop Idler	61	136573	Bracket, Wheel Gauge
29	73800600	Nut, Lock Hex W/Wsh 3/8-16 Unc	62	133943	Washer Hardened
30	133776	Bolt 5/16-18 x 1.25	63	72110612	Bolt Carriage 3/8-16 x 1-1/2
31	137266	Nut, Flg Top Lock Cntr 9/16	64	19121414	Washer 3/8 x 3/4 x 14Ga
32	129861	Pulley, Mandrel	67	73930600	Nut, Centerlock 3/8-16

NOTE: All component dimensions given in U.S. inches
1 inch = 25.4 mm

REPAIR PARTS

18 HP 44" TRACTOR - MODEL NUMBER 917.257720

TRANSAXLE

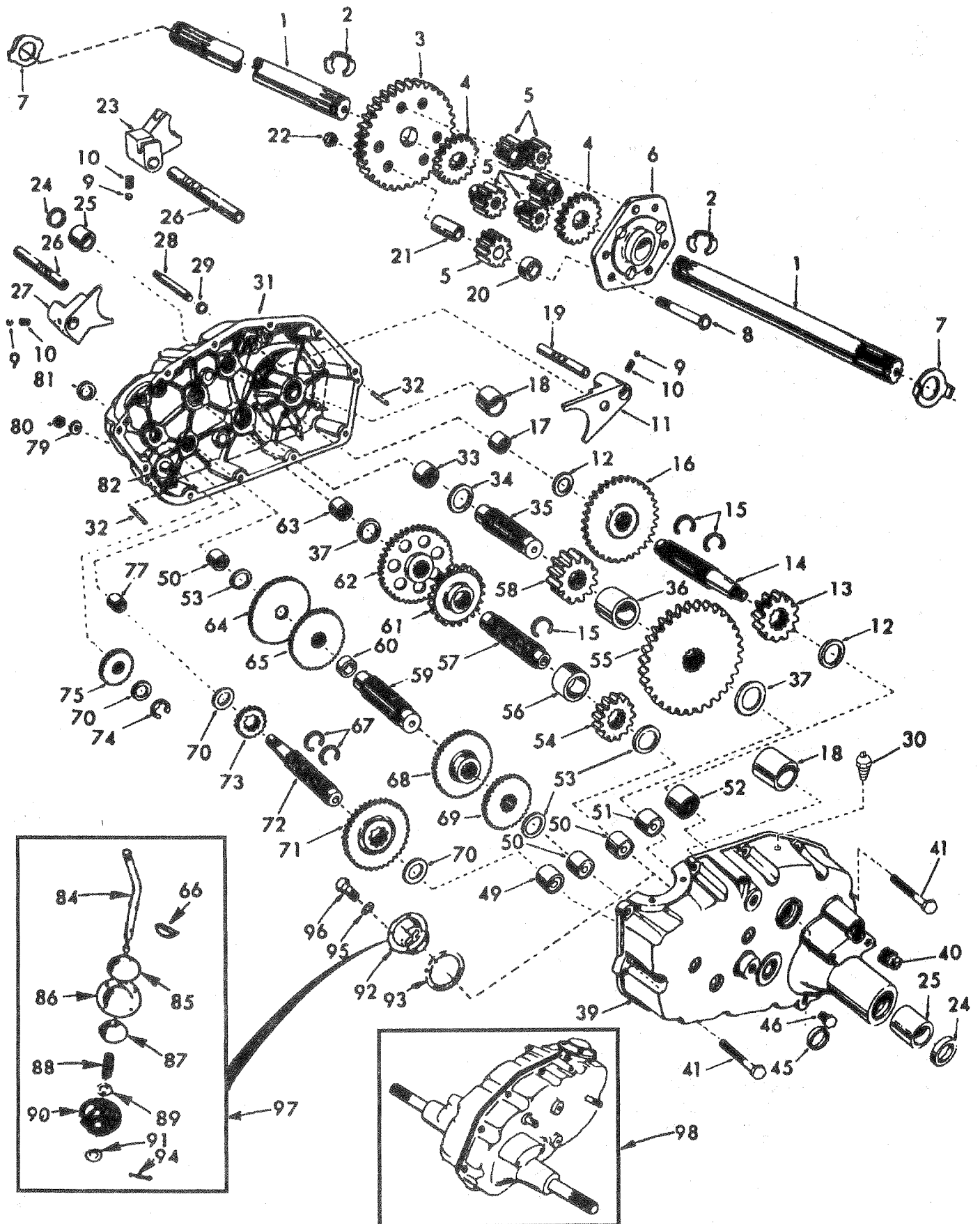

REPAIR PARTS

18 HP 44" TRACTOR - MODEL NUMBER 917.257720

TRANSAXLE

KEY PART NO. NO.	DESCRIPTION	KEY PART NO. NO.	DESCRIPTION
1	4197R	52	8119M Needle Bearing
2	12000034	53	4220R Thrust Bearing Race
3	4199R	54	4209R 3rd Reduction Pinion, Low
4	4216R	55	4213R 4th Reduction Gear
5	4215R	56	4442R 3rd Reduction Pinion Spacer
6	4217R	57	4195R 2nd Reduction Gear Shaft
7	6256H	58	4214R Final Drive Pinion
8	74020652	59	4194R 1st Reduction Gear Shaft
9	7392M	60	7528R 1st Reduction Shaft Spacer
10	137261	61	4208R 3rd Reduction Pinion High
11	4985R	62	4207R 2nd Reduction Gear
12	6266H	63	7398H Needle Bearing
13	4212R	64	4203R Low Speed Gear and 2nd Reduction Pinion Cluster
14	137125	65	4204R Reverse Gear
15	6276H	66	2898J Key, Hi-Pro 1/8 x 17/32
16	633A63	67	12000033 Klip Ring
17	8118M	68	4205R Intermediate Speed Gear
18	8740H1	69	4206R High Speed Gear
19	122238X	70	1370H Thrust Bearing Race
20	4218R	71	633A69 Intermediate and High Speed Cluster Pinions
21	6252H1	72	139120 Input Shaft
22	7810H	73	4201R Low Speed Pinion
23	6262H	74	12000008 E-Ring
24	7393R	75	1153R Reverse Idler Gear
25	992R1	77	6803J Needle Bearing
26	139111	79	1167R Sealing Washer
27	4986R	80	73360700 Nut, Hex, Jam 7/16-20
28	122254X	81	6270H Oil Seal
29	6269H	82	136984 Reverse Idler Shaft
30	5855H	84	5384J Gearshift Lever, Bent
31	139538	85	2978J Gearshift Cap
32	6277H	86	633A85 Gearshift Ball Cover and Pin
33	4225R	87	8739H1 Shift Lever Guide Ball, Keyed
34	7396H	88	4924H Spring
35	4198R	89	19151516 Washer 15/32 x 15/16 x 16 Gauge
36	4200R	90	110542X Shift Mechanism Seal
37	7395H	91	19181511 Washer 9/16 x 15/16 x 12 Gauge
39	139536	92	75J Gearshift Gate and Reinforcement
40	13320400	93	6274H Shift Ball Cover Gasket
41	17580520	94	76020412 Cotter Pin 1/8 x 3/4
45	6271H	95	10040500 Washer, Lock 5/16
46	13060200	96	74760514 Bolt, Hex Head 5/16-18 UNC x 7/8
49	4895H	97	633A109 Gearshift Lever Assembly
50	4222R	98	139535 Transaxle Assembly (Less Brake Drum and Shift Lever)
51	1529R		

NOTE: All component dimensions given in U.S. inches
1 inch = 25.4 mm

REPAIR PARTS

18 HP 44" TRACTOR - MODEL NUMBER 917.257720

KOHLER ENGINE - MODEL NUMBER MV18S, TYPE NUMBER 58560

AIR INTAKE

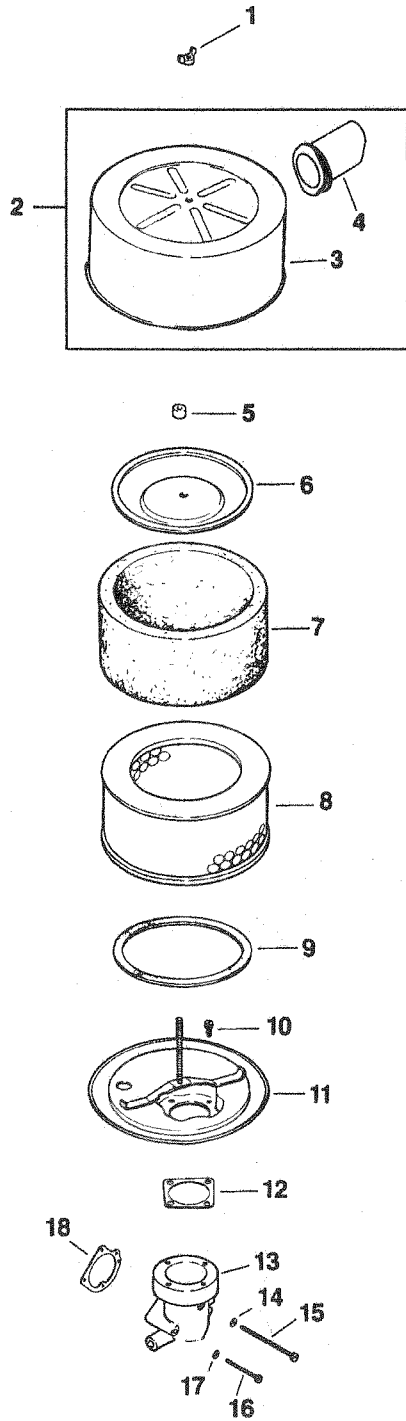

BAFFLES AND SHROUD

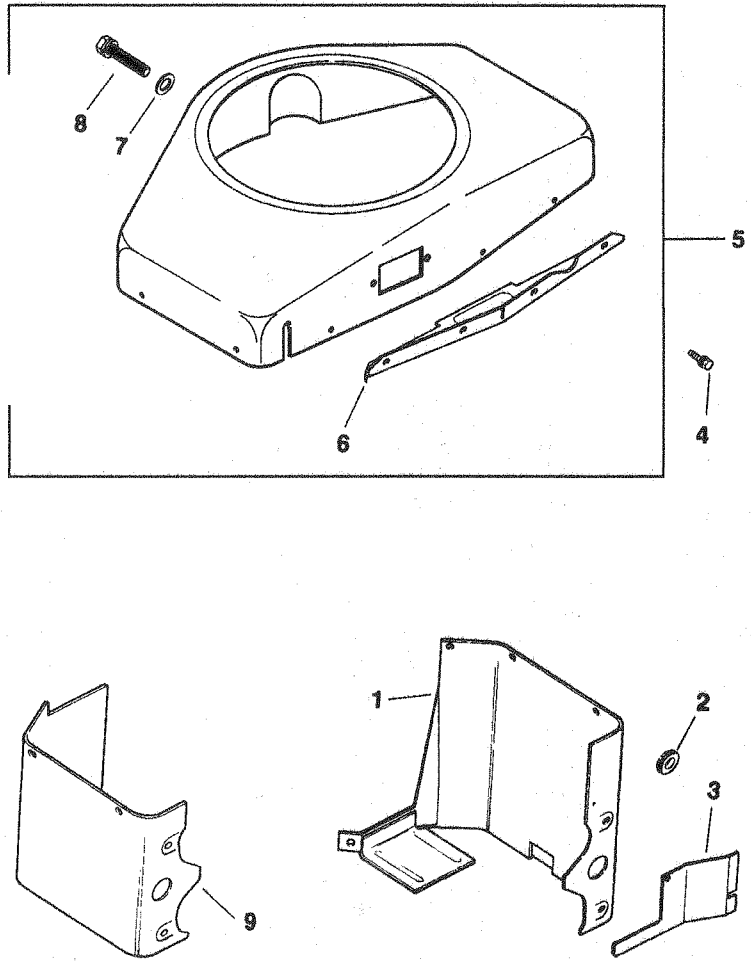

BREATHER AND VENT

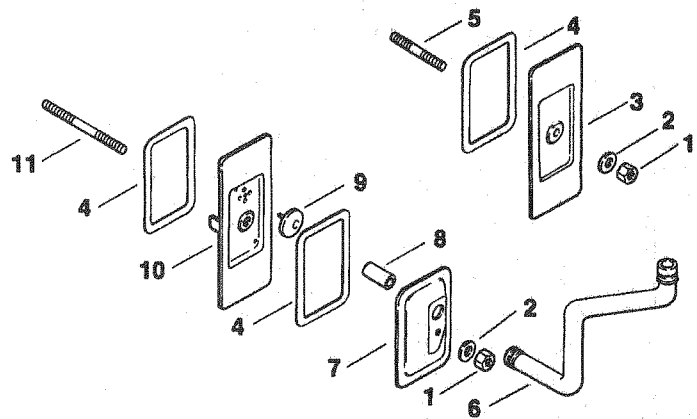

REPAIR PARTS

18 HP 44" TRACTOR - MODEL NUMBER 917.257720

KOHLER ENGINE - MODEL NUMBER MV18S, TYPE NUMBER 58560

AIR INTAKE

KEY PART NO. NO.	DESCRIPTION
1 X-276-7	Wing Nut 1/4-20
2 52 755 83	Kit, Cover and Tube (Includes Key Numbers 3 and 4)
3 52 096 35	Cover, Air Cleaner
4 52 123 21	Tube, Air Intake
5 231032	Seal, Element Cover
6 52 082 04	Cover, Air Cleaner Element
7 45 083 01	Pre-Cleaner
8 45 083 02	Element
9 237423	Seal, Air Cleaner Cover
10 X-67-98	Screw, Hex Washer Head #10-32 x 9/16 (4)
11 52 201 06	Base, Air Cleaner
12 277093	Gasket, Air Cleaner (2)
13 52 054 39	Elbow, Air Intake
14 X-25-79	Washer, Plain #10
15 X-50-37	Screw, Slotted Pan Head #10-32 x 2-1/4
16 X-50-57	Screw, Slotted Pan Head #10-32 x 1-3/4 (2)
17 X-22-9	Washer, Lock, Internal Tooth #10 (2)
18 25 041 06	Gasket, Air Cleaner Elbow

NOT ILLUSTRATED

-- 25 113 15	Decal, Air Cleaner
-- 52 113 30	Decal

BAFFLES & SHROUD

KEY PART NO. NO.	DESCRIPTION
1 52 063 41	Baffle, #2 Cylinder Head
2 52 313 05	Grommet (2)
3 52 063 42	Baffle, Fuel Pump
4 X-67-83	Screw, Hex Washer Head 1/4-20 x 7/16 (14)
5 52 755 70	Kit, Blower Housing (Includes Key Numbers 6 thru 8)
6 52 217 01	Support, Upper Housing
7 52 468 16	Washer, Flat (2)
8 52 086 11	Screw 1/4-20 x 5/8 (6)
9 52 124 23	Baffle, #1 Cylinder Head

NOT ILLUSTRATED

-- 52 113 46	Decal, Horsepower (3)
--------------	-----------------------

BREATHER & VENT

KEY PART NO. NO.	DESCRIPTION
1 X-81-1	Nut, Hex 1/4-20 (2)
2 X-25-12	Washer, Plain 1/4 (2)
3 52 096 18	Cover, #2 Cylinder Valve
4 52 055 01	Gasket, Cover (3)
5 X-352-39	Stud, #2 Cylinder Valve Cover 1/4-20 x 2-1/4
6 52 326 12	Hose, Breather
7 52 096 08	Cover, #1 Upper Cylinder Valve
8 52 032 04	Seal, Breather
9 52 462 01	Valve, Umbrella
10 52 096 22	Cover, #1 Lower Cylinder Valve
11 275220	Stud, #1 Cylinder Valve Cover 1/4-20 x 3-1/4

NOTE: All component dimensions given in U.S. inches
1 inch = 25.4 mm

REPAIR PARTS

18 HP 44" TRACTOR - MODEL NUMBER 917.257720

KOHLER ENGINE - MODEL NUMBER MV18S, TYPE NUMBER 58560

CRANKCASE

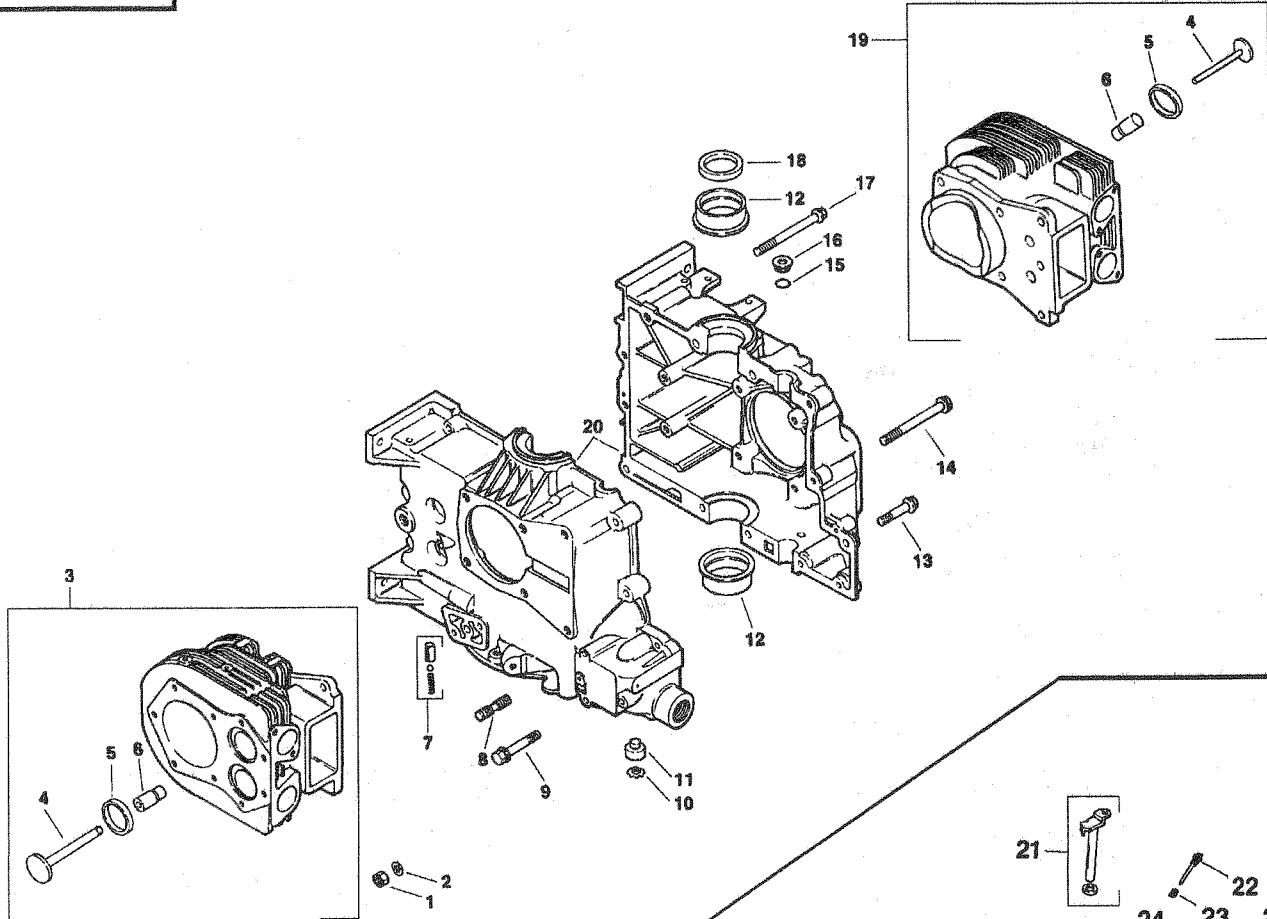

CARBURETOR

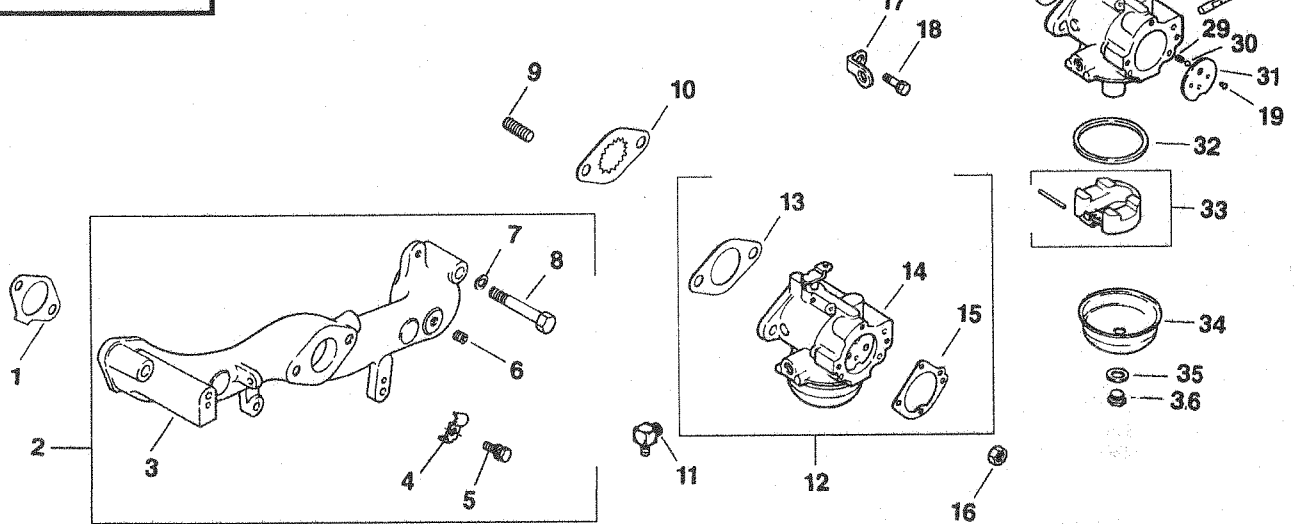

REPAIR PARTS

18 HP 44" TRACTOR - MODEL NUMBER 917.257720

KOHLER ENGINE - MODEL NUMBER MV18S, TYPE NUMBER 58560

CRANKCASE

KEY PART NO.	NO.	DESCRIPTION
1	X-82-2	Nut, Hex 5/16-18 (12)
2	52 468 12	Washer, Flat 5/16 (12)
3	82 755 16	Kit, #1 Cylinder Barrel (Includes Key Numbers 4 thru 6)
4	52 016 05	Valve, Exhaust
5	52 031 01	Insert, Valve Seat (2)
6	52 316 06	Guide, Valve (2)
7	52 755 50	Kit, Oil Relief
8	52 072 12	Step Stud 5/16-18 x 3/4, 3/8-16 x 5/8, 2" Long (12)
9	25 086 12	Screw, Hex Flange 5/16-18 x 2 (2)
10	X-269-43	Ring, Retaining
11	52 078 05	Shaft, Governor
12	52 030 10	Bearing, Sleeve, Standard (2)
	52 030 11	Bearing, Sleeve .010" (2)
	52 030 12	Bearing, Sleeve .020" (2)
13	25 086 10	Screw, Hex Flange 5/16-18 x 1-1/2 (3)
14	25 086 13	Screw, Hex Flange 3/8-16 x 3-5/8 (2)
15	52 141 02	O-Ring
16	52 139 08	Plug
17	25 086 11	Screw, Hex Flange 5/16-18 x 3-1/2 (8)
18	52 032 10	Seal, Oil, Front
19	82 755 17	Kit, #2 Cylinder Barrel (Includes Key Numbers 4 thru 6)
20	---	Crankcase (Service with Short Block, Part Number 82 522 30)

CARBURETOR

KEY PART NO.	NO.	DESCRIPTION
1	52 041 09	Gasket, Intake (2)
2	52 755 91	Kit, Manifold (Includes Key Numbers 3 thru 8)
3	52 164 15	Manifold, Intake
4	X-21-1	Washer, Lock 5/16 (4)
5	X-6-29	Screw, Hex Cap 5/16-18 x 2 (4)
6	X-75-23	Plug, Hex, Countersunk 1/8 N.P.T.F.
7	235778	Clamp, Cable (2)
8	X-67-97	Screw, Hex Washer Head #10-24 x 3/8 (2)
9	41 072 19	Stud 5/16-18 x 1 (2)
10	52 063 40	Baffle, Carburetor
11	25 155 02	Connector, Hose
12	52 853 25	Kit, Carburetor with Gasket (Includes Key Numbers 12 thru 14)
13	271030	Gasket, Carburetor (2)
14	52 053 54	Carburetor Assembly (Information Only - Not Available Separately) (Includes Key Numbers 18 thru 35)
15	25 041 06	Gasket, Air Cleaner
16	X-77-2	Nut 5/16 (2)
17	232867	Strap, Lifting
18	X-67-62	Screw, Hex Washer Head 1/4-20 x 3/4
19	25 086 27	Screw, Throttle and Choke Plate (4)
20	25 146 03	Plate, Choke
21	52 144 24	Shaft, Throttle with Lever and Seal
22	25 368 01	Needle, Idle Fuel Adjust
23	25 089 02	Spring, Idle, Fuel
24	25 086 26	Screw, Idle Speed Adjust
25	25 089 04	Spring, Idle Speed
26	25 368 03	Needle, Main Fuel
27	25 089 02	Spring, Main Fuel
28	52 090 13	Lever, Choke
29	25 089 03	Spring, Choke, Friction
30	25 194 01	Ball, Choke, Friction
31	25 146 02	Plate, Throttle
32	25 041 04	Gasket, Bowl
33	25 757 09	Kit, Float
34	25 104 01	Bowl, Fuel
35	25 041 03	Gasket, Bowl Retainer Screw
36	25 100 05	Screw, Bowl Retainer

NOT ILLUSTRATED

--	25 757 11	Kit, Carburetor Repair
--	25 757 23	Kit, Bowl Baffle

NOTE: All component dimensions given in U.S. inches
1 inch = 25.4 mm

REPAIR PARTS

18 HP 44" TRACTOR - MODEL NUMBER 917.257720

KOHLER ENGINE - MODEL NUMBER MV18S, TYPE NUMBER 58560

CRANKSHAFT

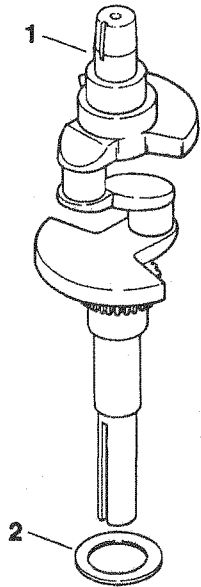

DIPSTICK

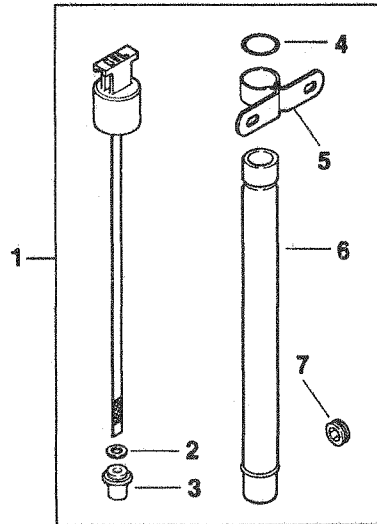

CYLINDER HEAD

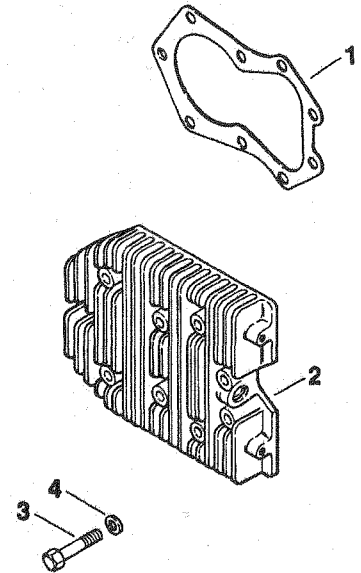

ELECTRIC STARTER

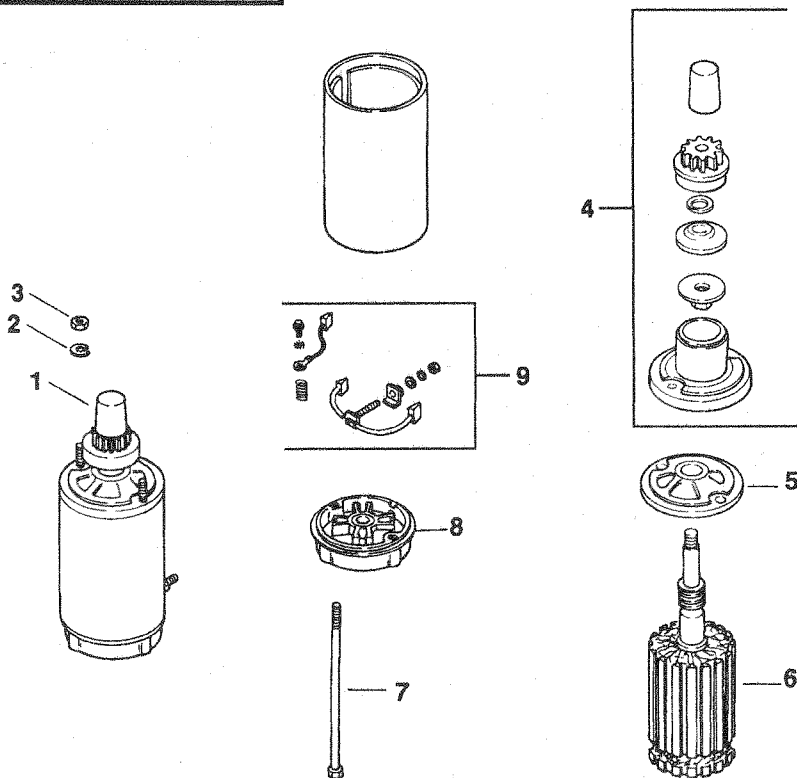

EXHAUST

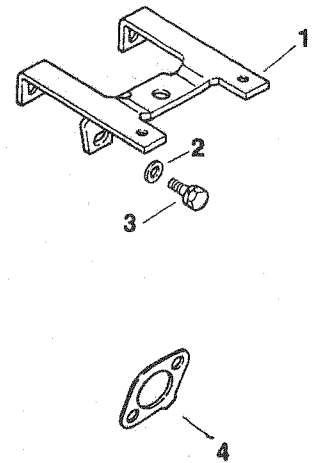

REPAIR PARTS

18 HP 44" TRACTOR - MODEL NUMBER 917.257720

KOHLER ENGINE - MODEL NUMBER MV18S, TYPE NUMBER 58560

CRANKSHAFT

KEY PART NO. NO.	DESCRIPTION
1 52 014 93	Crankshaft
2 52 468 03	Washer, Thrust .119/.122 (A.R.)
52 468 04	Washer, Thrust .128/.131
52 468 05	Washer, Thrust .137/.140 (A.R.)

DIPSTICK

KEY PART NO. NO.	DESCRIPTION
1 52 038 14	Dipstick Assembly (Includes Key Numbers 2 and 3)
2 X-25-44	Washer, Plain 5/16
3 52 032 14	Seal, Rubber
4 41 153 01	O-Ring
5 52 126 11	Bracket, Oil Tube Support
6 52 123 20	Tube, Oil Fill 11-7/8
7 47 139 01	Plug, Hex, Countersunk 3/4 N.P.T.F.

CYLINDER HEAD

KEY PART NO. NO.	DESCRIPTION
1 52 041 20	Gasket, Head (2)
2 52 015 08	Cylinder Head (2)
3 220534	Washer, Plain 5/16 (18)
4 41 086 02	Screw, Hex Head 5/16-18 x 1-1/2 (18)

ELECTRIC STARTER

KEY PART NO. NO.	DESCRIPTION
1 52 098 12	Starter Assembly (Includes Key Numbers 4 thru 9)
2 X-20-1	Washer, Lock 1/4 (2)
3 X-81-1	Nut, Hex 1/4-20 (2)
4 82 755 26	Kit, Drive
5 52 081 07	Cap, Drive End
6 52 170 05	Armature
7 52 211 01	Bolt, Thru (2)
8 52 227 10	Cap, Commutator End
9 82 755 28	Kit, Brush

NOT ILLUSTRATED

-- 25 450 03	Tag, Caution
--------------	--------------

EXHAUST

KEY PART NO. NO.	DESCRIPTION
1 52 126 12	Bracket
2 X-25-72	Washer, Plain (3)
3 52 086 11	Screw 1/4-20 x 5/8 (3)
4 52 041 14	Gasket, Exhaust (2)

NOTE: All component dimensions given in U.S. inches
1 inch = 25.4 mm

REPAIR PARTS

18 HP 44" TRACTOR - MODEL NUMBER 917.257720

KOHLER ENGINE - MODEL NUMBER MV18S, TYPE NUMBER 58560

GOVERNOR

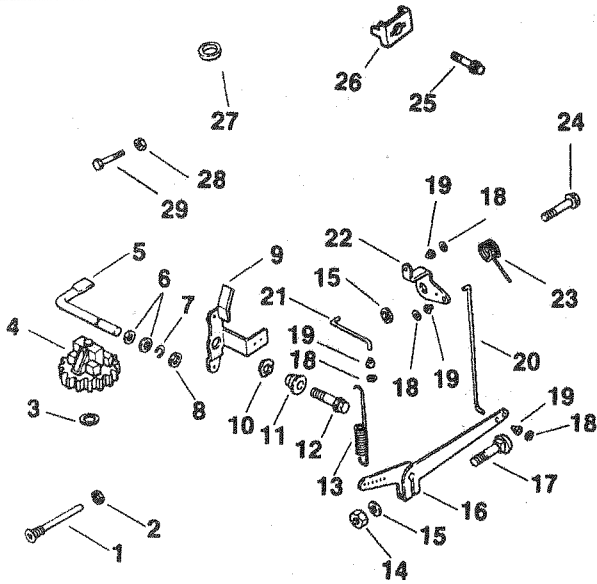

FUEL PUMP

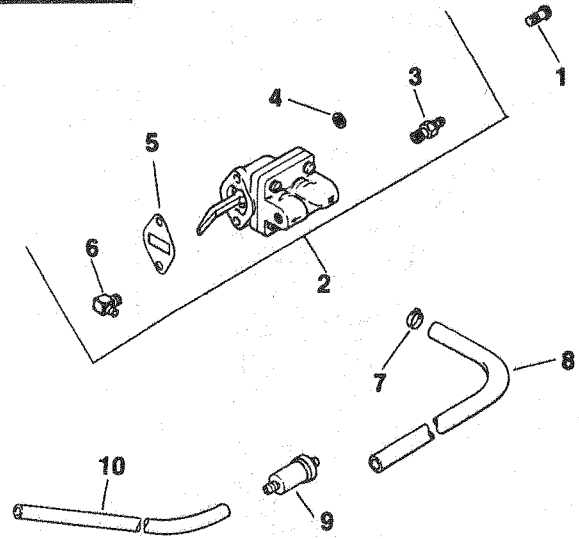

IGNITION

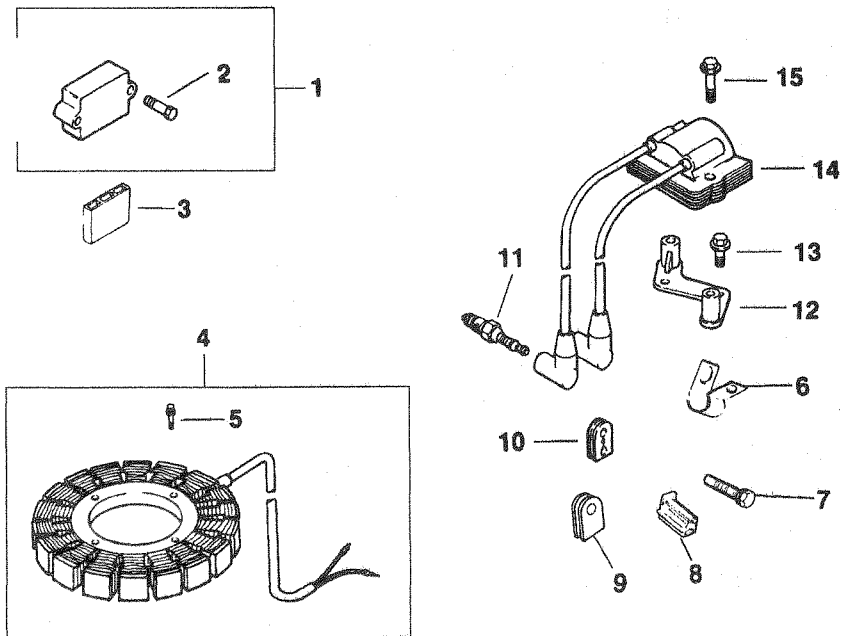

FLYWHEEL

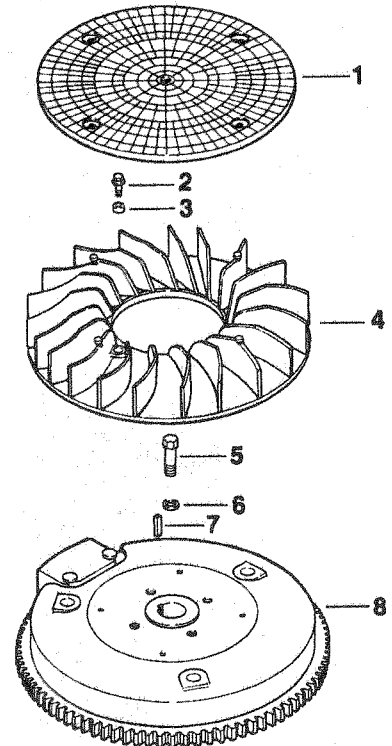

REPAIR PARTS

18 HP 44" TRACTOR - MODEL NUMBER 917.257720

KOHLER ENGINE - MODEL NUMBER MV18S, TYPE NUMBER 58560

FLYWHEEL

KEY PART NO. NO.	DESCRIPTION
1 25 162 01	Screen, Grass
2 25 086 21	Screw, Hex Washer Head 1/4-20 x 5/8 (4)
3 25 112 04	Spacer (4)
4 25 157 01	Fan
5 25 086 24	Screw, Hex Machine 3/8-24 x 1-1/4
6 52 468 15	Washer, Plain
7 X-286-17	Key, Square 3/16 x 7/8
8 52 025 36	Flywheel

GOVERNOR

KEY PART NO. NO.	DESCRIPTION
1 231355	Pin, Governor Stop
2 X-25-12	Washer, Plain 1/4
3 237022	Washer, Thrust
4 A-235743-S	Kit, Governor Gear
5 52 078 04	Shaft, Governor Cross
6 X-25-102	Washer, Plain 1/4 (2)
7 X-269-28	Retainer, Governor
8 X-25-72	Washer, Plain 1/4 (2)
9 52 090 23	Lever, Speed Control
10 277341	Washer, Tension
11 52 158 07	Bushing, Throttle Control Lever
12 25 086 15	Screw, Hex Washer Head 1/4-20 x 1
13 52 089 07	Spring, Governor
14 X-81-1	Nut, Hex 1/4-20
15 X-25-63	Washer, Plain 1/4
16 52 186 09	Arm, Governor
17 52 211 04	Screw, Round Head, Square Neck 1/4-20 x 1
18 25 141 03	Ring, Retaining (4)
19 25 158 08	Bushing, Linkage Retaining (4)
20 52 079 07	Linkage, Governor
21 52 079 06	Linkage, Throttle
22 52 090 14	Lever, Throttle
23 52 089 08	Spring, Torsion
24 25 086 21	Screw, Hex Washer Head 1/4-20 x 5/8
25 X-67-97	Screw, Hex Washer Head #10-24 x 3/8 (3)
26 235778	Clamp, Cable (3)
27 25 431 01	Bushing, Speed Control Lever
28 X-70-3	Nut, Hex #10-32
29 52 086 05	Screw, Hex Head #10-32 x 7/8

FUEL PUMP

KEY PART NO. NO.	DESCRIPTION
1 47 086 08	Screw, Pozidriv, Truss Head 1/4-20 x 5/8 (2)
2 52 559 01	Pump, Fuel Assembly (Includes Key Numbers 3 thru 6)
3 X-380-1	Connector, Straight
4 X-25-63	Washer, Plain 1/4 (2)
5 25 041 09	Gasket, Fuel Pump
6 25 155 02	Connector, Hose
7 X-426-9	Clamp, Hose (4)
8 52 353 18	Line, Fuel, 8"
9 25 050 03	Filter, Fuel
10 15 353 04	Line, Fuel, 11-1/2"

IGNITION

KEY PART NO. NO.	DESCRIPTION
1 25 755 03	Kit, Rectifier-Regulator (Includes Key Number 2)
2 X-132-5	Screw, Hex Cap 1/4-20 x 5/8 (2)
3 236602	Connector, 3 Contact
4 237878	Kit, Stator (Includes Key Number 5)
5 X-67-51	Screw, Hex Cap #10-24 x 3/4 (2)
6 210281	Clip (2)
7 X-67-64	Screw, Hex Washer Head #10-32 x 7/16
8 41 155 03	Connector, 2 Contact
9 220297	Grommet, Rubber
10 52 313 02	Grommet
11 52 132 02	Spark Plug (2)
12 52 126 08	Bracket, Module
13 25 086 15	Screw, Hex Washer Head 1/4-20 x 1 (2)
14 52 584 02	Module, Ignition
15 25 086 16	Screw, Hex Washer Head 1/4-20 x 7/8 (2)

NOT ILLUSTRATED

-- 47 518 33	Lead, Violet, Rectifier-Regulator (11", 14 Gauge, Uninsulated Push On Tab Terminals)
-- 52 518 19	Lead, White, Module To Connector (19-1/2", 14 Gauge, Insulated Push On Tab, Uninsulated Push On Tab Terminals)

NOTE: All component dimensions given in U.S. inches
1 inch = 25.4 mm

REPAIR PARTS

18 HP 44" TRACTOR - MODEL NUMBER 917.257720

KOHLER ENGINE - MODEL NUMBER MV18S, TYPE NUMBER 58560

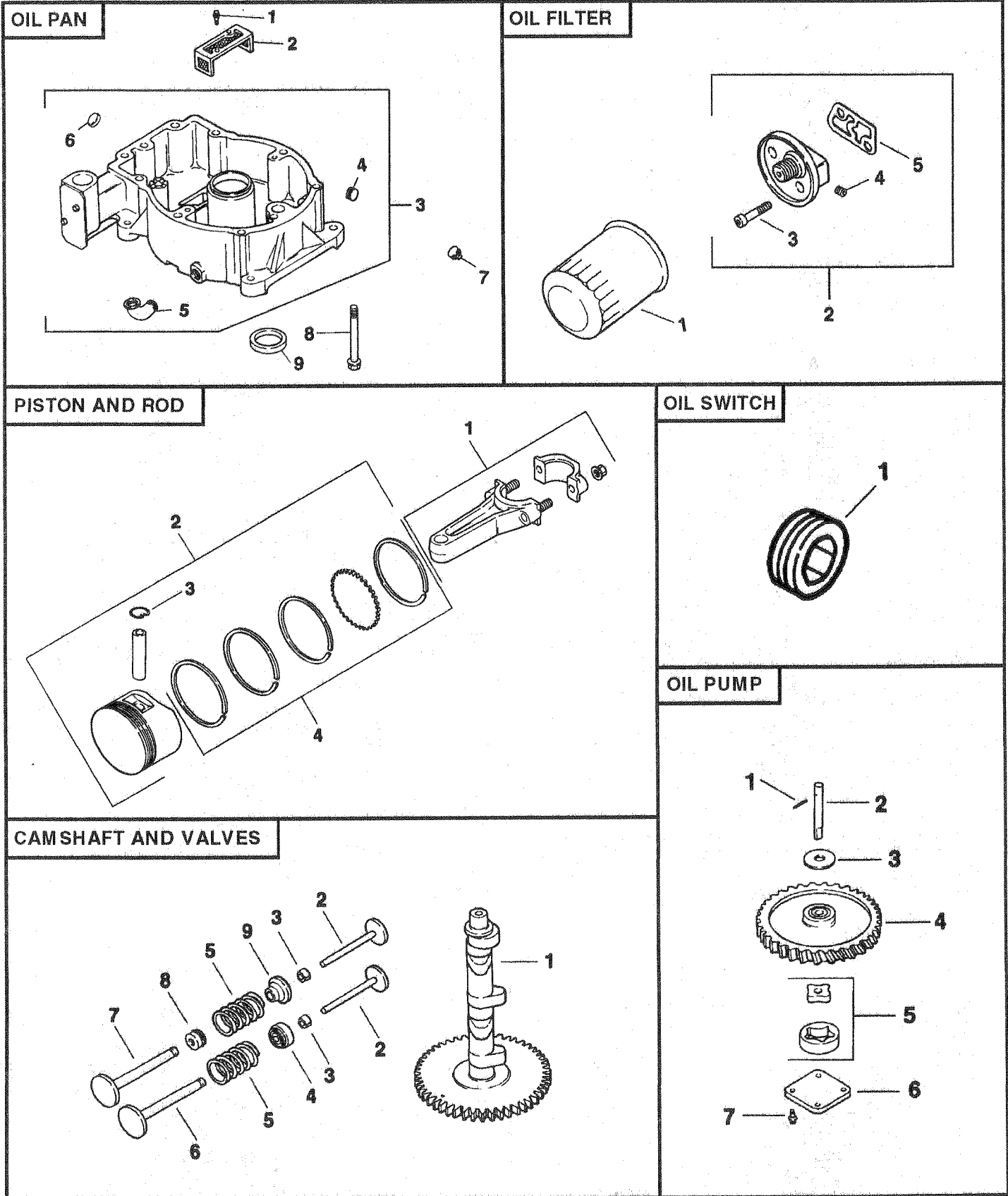

REPAIR PARTS

18 HP 44" TRACTOR - MODEL NUMBER 917.257720

KOHLER ENGINE - MODEL NUMBER MV18S, TYPE NUMBER 58560

OIL PAN

KEY PART NO. NO.	DESCRIPTION
1 X-67-64	Screw, Hex Washer Head #10-32 x 7/16 (2)
2 52 050 03	Filter, Oil Pickup
3 52 199 14	Oil Pan (Includes Key #4 thru 6)
4 X-702-14	Plug, Cup 1-1/16
5 52 054 07	Elbow, Street
6 X-75-38	Plug, Hex, Countersunk 1/4 N.P.T.F.
7 X-75-10	Plug, Square Head 3/8 N.P.T.F. (2)
8 52 086 12	Screw, Hex Washer Head 5/16-18 x 1-1/4 (9)
9 52 032 10	Seal, Oil, Rear

OIL FILTER

KEY PART NO. NO.	DESCRIPTION
1 52 050 02	Oil Filter
2 82 755 23	Kit, Oil Filter Adaptor (Includes Key Numbers 3 thru 5)
3 X-55-15	Screw, Hex Socket Head 5/16-18 x 1-1/4 (2)
4 X-75-23	Plug, Hex, Countersunk 1/8 N.P.T.F.
5 52 041 16	Gasket, Oil Filter

PISTON & ROD

KEY PART NO. NO.	DESCRIPTION
1 52 067 67	Connecting Rod, Standard (2)
52 067 68	Connecting Rod .010" (2)
2 52 874 11	Piston with Ring Set, Standard (2)
52 874 12	Piston with Ring Set .003" (2)
52 874 13	Piston with Ring Set .010" (2)
52 874 14	Piston with Ring Set .020" (2)
52 874 15	Piston with Ring Set .030" (2)
3 230004	Retainer, Piston Pin (4)
4 52 108 09	Ring Set, Standard and .003" (2)

52 108 10	Ring Set .010" (2)
52 108 11	Ring Set .020" (2)
52 108 12	Ring Set .030" (2)

LOW OIL PRESSURE SWITCH

KEY PART NO. NO.	DESCRIPTION
1 X-75-23	Plug, Pipe 1/8 N.P.T.F.

CAMSHAFT & VALVES

KEY PART NO. NO.	DESCRIPTION
1 52 012 09	Camshaft
2 52 019 03	Tappet (4)
3 41 755 10	Kit, Retainer (4)
4 52 413 01	Rotator, Exhaust Valve (2)
5 25 089 01	Spring, Valve (4)
6 52 016 05	Valve, Exhaust (2)
7 52 017 08	Valve, Intake (2)
8 52 032 13	Seal, Intake Valve Stem (2)
9 230011	Retainer, Intake Valve (2)

OIL PUMP

KEY PART NO. NO.	DESCRIPTION
1 X-280-25	Pin, Roll
2 52 144 05	Shaft, Oil Pump
3 52 422 01	Spacer, Shim (As Required, Maximum of 2)
4 52 043 05	Gear, Oil Pump
5 52 393 09	Rotor Set
6 52 096 03	Cover, Oil Pump
7 X-67-64	Screw, Hex Washer Head #10-32 x 7/16 (4)

NOT ILLUSTRATED

-- 82 522 30	Short Block
-- 52 755 94	Gasket Set

RPM Settings: Low Speed: 1150-1650
High Speed: 3200-3400

NOTE: All component dimensions given in U.S. inches
1 inch = 25.4 mm

SERVICE NOTES

SUGGESTED GUIDE FOR SIGHTING SLOPES FOR SAFE OPERATION

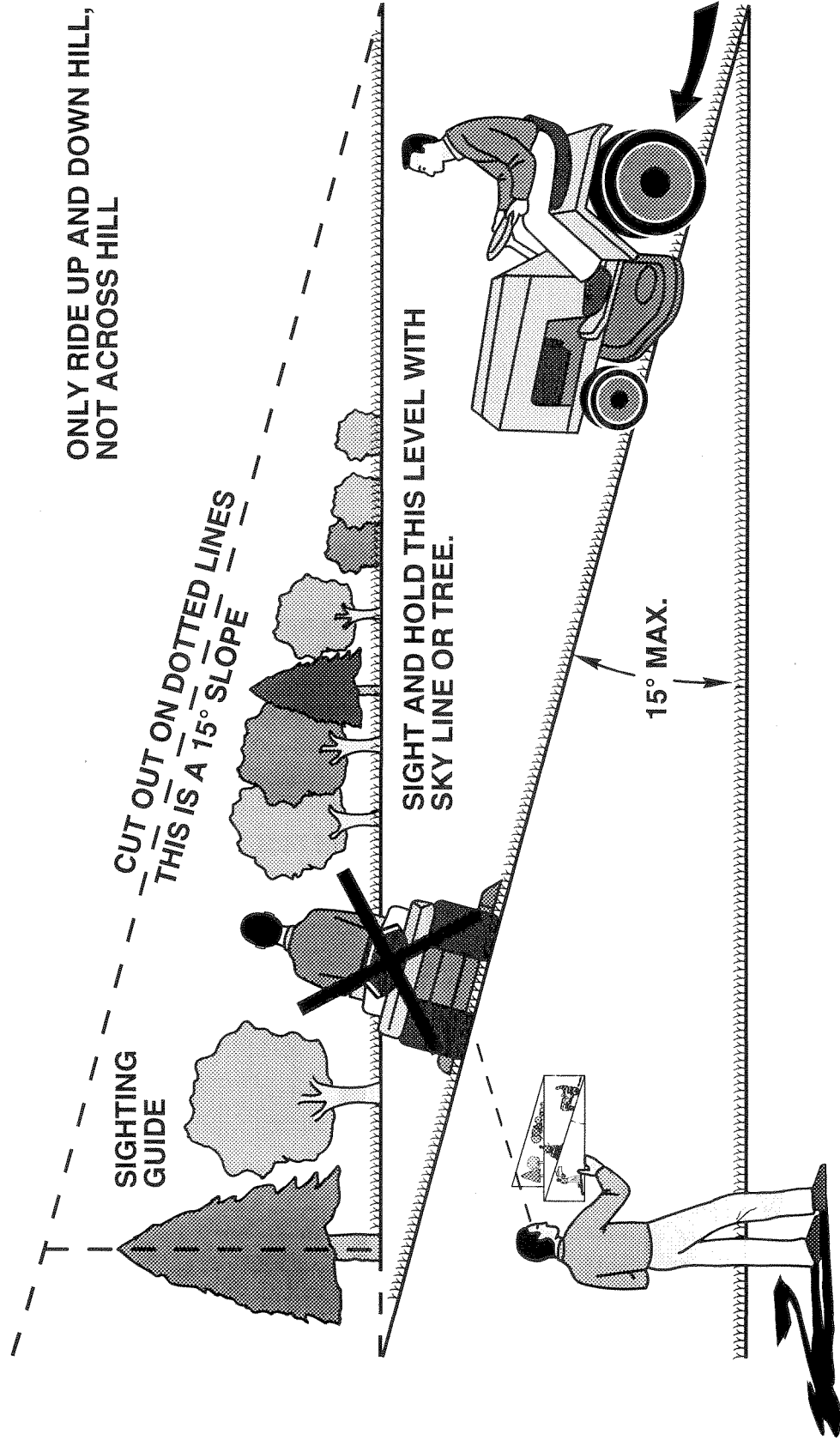

 Operate your Tractor up and down the face of slopes (not greater than 15°), never across the face. Make turns gradually to prevent tipping or loss of control. Exercise extreme caution when changing direction on slopes.

SEARS

**OWNER'S
MANUAL**

**MODEL NO.
917.257720**

**IF YOU NEED
REPAIR SERVICE
OR PARTS:**

FOR REPAIR SERVICE, CALL
THIS TOLL FREE NUMBER:

1-800-4-REPAIR
(1-800-473-7247)

FOR REPLACEMENT PARTS
INFORMATION AND
ORDERING, CALL THIS
TOLL FREE NUMBER:

1-800-FON-PART
(1-800-366-7278)

CRAFTSMAN®

**18.0 HP IC
ELECTRIC START
44" MOWER
6 SPEED TRANSAXLE
GARDEN TRACTOR**

Each tractor has its own model number. Each engine has its own model number.

The model number for your tractor will be found on the model plate located under the seat.

The model number for your engine will be found on the blower housing of the engine.

All parts listed herein may be ordered from any Sears, Roebuck and Co. Service Center/Department and most Retail Stores.

**WHEN ORDERING REPAIR PARTS, ALWAYS GIVE THE
FOLLOWING INFORMATION:**

- **PRODUCT - TRACTOR**
- **MODEL NUMBER - 917.257720**
- **ENGINE MODEL NO. - MV18S-58556**
- **PART NUMBER**
- **PART DESCRIPTION**

Your Sears merchandise has added value when you consider Sears has service units nationwide staffed with Sears trained technicians... professional technicians specifically trained to insure that we meet our pledge to you, we service what we sell.

FILE COPY