

**SEARS**  
OWNER'S  
MANUAL

MODEL NO.  
944.604881

**Important:**  
Read and follow  
all Safety Rules  
and Instructions  
Before Operating  
This Equipment

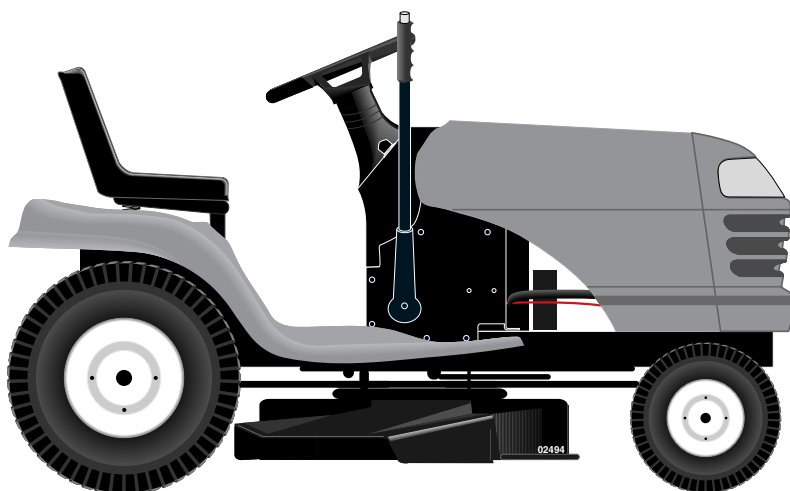

**CRAFTSMAN®**

00007

**18.0 HP  
ELECTRIC START  
42" MOWER  
AUTOMATIC  
LAWN TRACTOR**

- Assembly
- Operation
- Maintenance
- Service and Adjustments
- Repair Parts

# SAFETY RULES



## SAFE OPERATION PRACTICES FOR RIDE-ON MOWERS



**IMPORTANT:** THIS CUTTING MACHINE IS CAPABLE OF AMPUTATING HANDS AND FEET AND THROWING OBJECTS. FAILURE TO OBSERVE THE FOLLOWING SAFETY INSTRUCTIONS COULD RESULT IN SERIOUS INJURY OR DEATH.

### I. GENERAL OPERATION

- Read, understand, and follow all instructions in the manual and on the machine before starting.
- Only allow responsible adults, who are familiar with the instructions, to operate the machine.
- Clear the area of objects such as rocks, toys, wire, etc., which could be picked up and thrown by the blade.
- Be sure the area is clear of other people before mowing. Stop machine if anyone enters the area.
- Never carry passengers.
- Do not mow in reverse unless absolutely necessary. Always look down and behind before and while backing.
- Be aware of the mower discharge direction and do not point it at anyone. Do not operate the mower without either the entire grass catcher or the guard in place.
- Slow down before turning.
- Never leave a running machine unattended. Always turn off blades, set parking brake, stop engine, and remove keys before dismounting.
- Turn off blades when not mowing.
- Stop engine before removing grass catcher or unclogging chute.
- Mow only in daylight or good artificial light.
- Do not operate the machine while under the influence of alcohol or drugs.
- Watch for traffic when operating near or crossing roadways.
- Use extra care when loading or unloading the machine into a trailer or truck.
- Data indicates that operators, age 60 years and above, are involved in a large percentage of riding mower-related injuries. These operators should evaluate their ability to operate the riding mower safely enough to protect themselves and others from serious injury.
- Keep machine free of grass, leaves or other debris build-up which can touch hot exhaust / engine parts and burn. Do not allow the mower deck to plow leaves or other debris which can cause build-up to occur. Clean any oil or fuel spillage before operating or storing the machine. Allow machine to cool before storage.

### II. SLOPE OPERATION

Slopes are a major factor related to loss-of-control and tipover accidents, which can result in severe injury or death. All slopes require extra caution. If you cannot back up the slope or if you feel uneasy on it, do not mow it.

#### DO:

- Mow up and down slopes, not across.
- Remove obstacles such as rocks, tree limbs, etc.
- Watch for holes, ruts, or bumps. Uneven terrain could overturn the machine. *Tall grass can hide obstacles.*
- Use slow speed. Choose a low gear so that you will not have to stop or shift while on the slope.
- Follow the manufacturer's recommendations for wheel weights or counterweights to improve stability.
- Use extra care with grass catchers or other attachments. These can change the stability of the machine.
- Keep all movement on the slopes *slow* and *gradual*. Do not make sudden changes in speed or direction.
- Avoid starting or stopping on a slope. If tires lose traction, disengage the blades and proceed slowly *straight* down the slope.

#### DO NOT:

- *Do not* turn on slopes unless necessary, and then, turn slowly and gradually downhill, if possible.
- *Do not* mow near drop-offs, ditches, or embankments. The mower could suddenly turn over if a wheel is over the edge of a cliff or ditch, or if an edge caves in.
- *Do not* mow on wet grass. Reduced traction could cause sliding.
- *Do not* try to stabilize the machine by putting your foot on the ground.
- *Do not* use grass catcher on steep slopes.

### III. CHILDREN

Tragic accidents can occur if the operator is not alert to the presence of children. Children are often attracted to the machine and the mowing activity. *Never* assume that children will remain where you last saw them.

- Keep children out of the mowing area and under the watchful care of another responsible adult.
- Be alert and turn machine off if children enter the area.
- Before and when backing, look behind and *down* for small children.
- Never carry children. They may fall off and be seriously injured or interfere with safe machine operation.
- Never allow children to operate the machine.
- Use extra care when approaching blind corners, shrubs, trees, or other objects that may obscure vision.

### IV. SERVICE

- Use extra care in handling gasoline and other fuels. They are flammable and vapors are explosive.
  - Use only an approved container.
  - Never remove gas cap or add fuel with the engine running. Allow engine to cool before refueling. Do not smoke.
  - Never refuel the machine indoors.
  - Never store the machine or fuel container inside where there is an open flame, such as a water heater.
- Never run a machine inside a closed area.
- Keep nuts and bolts, especially blade attachment bolts, tight and keep equipment in good condition.
- Never tamper with safety devices. Check their proper operation regularly.
- Keep machine free of grass, leaves, or other debris build-up. Clean oil or fuel spillage. Allow machine to cool before storing.
- Stop and inspect the equipment if you strike an object. Repair, if necessary, before restarting.
- Never make adjustments or repairs with the engine running.
- Grass catcher components are subject to wear, damage, and deterioration, which could expose moving parts or allow objects to be thrown. Frequently check components and replace with manufacturer's recommended parts, when necessary.
- Mower blades are sharp and can cut. Wrap the blade(s) or wear gloves, and use extra caution when servicing them.
- Check brake operation frequently. Adjust and service as required.

# SAFETY RULES



## SAFE OPERATION PRACTICES FOR RIDE-ON MOWERS



- Be sure the area is clear of other people before mowing. Stop machine if anyone enters the area.
- Never carry passengers or children even with the blades off.
- Do not mow in reverse unless absolutely necessary. Always look down and behind before and while backing.
- Never carry children. They may fall off and be seriously injured or interfere with safe machine operation.
- Keep children out of the mowing area and under the watchful care of another responsible adult.
- Be alert and turn machine off if children enter the area.
- Before and when backing, look behind and down for small children.
- Mow up and down slopes (15° Max), not across.
- Remove obstacles such as rocks, tree limbs, etc.
- Watch for holes, ruts, or bumps. Uneven terrain could overturn the machine. Tall grass can hide obstacles.
- Use slow speed. Choose a low gear so that you will not have to stop or shift while on the slope.
- Avoid starting or stopping on a slope. If tires lose traction, disengage the blades and proceed slowly straight down the slope.
- If machine stops while going uphill, disengage blades, shift into reverse and back down slowly.
- Do not turn on slopes unless necessary, and then, turn slowly and gradually downhill, if possible.



**WARNING:** Do not coast down a hill in neutral, you may lose control of the tractor.



**WARNING:** Tow only the attachments that are recommended by and comply with specifications of the manufacturer of your tractor. Use common sense when towing. Operate only at the lowest possible speed when on a slope. Too heavy of a load, while on a slope, is dangerous. Tires can lose traction with the ground and cause you to lose control of your tractor.



**WARNING:** In order to prevent accidental starting when setting up, transporting, adjusting or making repairs, always disconnect spark plug wire and place wire where it cannot contact spark plug.

## TABLE OF CONTENTS

SAFETY RULES .....	2-3
PRODUCT SPECIFICATIONS .....	4
WARRANTY .....	4
CUSTOMER RESPONSIBILITIES.....	4
ASSEMBLY .....	6-8
OPERATION .....	9-14
MAINTENANCE SCHEDULE .....	15

MAINTENANCE .....	15-19
SERVICE AND ADJUSTMENTS .....	20-25
STORAGE .....	26
TROUBLESHOOTING .....	27-28
REPAIR PARTS - TRACTOR .....	30-47
REPAIR PARTS - ENGINE.....	48-53
PARTS ORDERING/SERVICE.....	BACK COVER

## PRODUCT SPECIFICATIONS

Gasoline Capacity and type:	1.25 Gallons Unleaded Regular
Oil Type (API-SF-SJ):	SAE 30 (above 32°F) SAE 5W-30 (below 32°F) SYNTHETIC (Below 0°F)
Your tractor was shipped from the factory with non-synthetic SAE 10W-30 motor oil	
Oil Capacity:	W/ Filter: 3.5Pints W/O Filter: 3.0Pints
Spark Plug: (Gap: .030")	Champion RC12YC
Ground Speed (MPH):	Forward: 5.2 Reverse: 2.7
Tire Pressure:	Front: 14 PSI Rear: 10 PSI
Charging System:	3 Amps Battery 5 Amps Headlights
Battery:	AMP/HR: 28 MIN. CCA: 230 CASE SIZE: U1R
Blade Bolt Torque:	27-35 FT. LBS.

**CONGRATULATIONS** on your purchase of a new tractor. It has been designed, engineered and manufactured to give you the best possible dependability and performance.

Should you experience any problem you cannot easily remedy, please contact your nearest authorized service center/department. We have competent, well-trained technicians and the proper tools to service or repair this tractor.

Please read and retain this manual. The instructions will enable you to assemble and maintain your tractor properly. Always observe the "SAFETY RULES".

## MAINTENANCE AGREEMENT

A Maintenance Agreement is available on this product. Contact your nearest Sears store for details.

## CUSTOMER RESPONSIBILITIES

- Read and observe the safety rules.
- Follow a regular schedule in maintaining, caring for and using your tractor.
- Follow the instructions under "Maintenance" and "Storage" sections of this owner's manual.

**WARNING:** This tractor is equipped with an internal combustion engine and should not be used on or near any unimproved forest-covered, brush-covered or grass-covered land unless the engine's exhaust system is equipped with a spark arrester meeting applicable local or state laws (if any). If a spark arrester is used, it should be maintained in effective working order by the operator.

A spark arrester for the muffler is available through your nearest authorized service center/department (See REPAIR PARTS section of this manual).

# WARRANTY

### LIMITED TWO (2) YEAR WARRANTY ON CRAFTSMAN TRACTOR (RIDING EQUIPMENT)

For two (2) years from date of purchase Sears Canada, Inc. will repair or replace at Sears option free of charge parts which are defective as a result of material or workmanship.

### FULL ONE (1) YEAR WARRANTY ON BATTERY

For one (1) year from date of purchase, if any battery included with this riding equipment proves defective in material or workmanship and our testing determines the battery will not hold a charge, Sears will replace the battery at no charge.

### COMMERCIAL OR RENTAL USE

Warranty on Riding Equipment used for commercial or rental purposes is limited to ninety (90) days.

### This Warranty does **NOT** cover:

1. Pre-delivery set-up.
2. Tire replacement or repair caused by punctures from outside objects (such as nails, thorns, stumps, or glass).
3. Expendable items which become worn during normal use, such as blades, spark plug, air cleaners and belts.
4. Repairs necessary because of operator abuse or negligence, including damaged jackshaft or mandrel and the failure to operate and maintain the equipment according to the instructions contained in the Owner's Manual.
5. In Home service.

Warranty service is available by returning the Craftsman Riding Equipment to the nearest Sears Service Centre/Department in Canada. This warranty applies only while this product is in use in Canada.

This warranty is in addition to any statutory warranty and does not exclude or limit legal rights you may have but shall run concurrently with applicable provincial legislation. Furthermore, some provinces do NOT allow limitation on how long an implied warranty will last so the above limitations may not apply to you.

**SEARS CANADA, INC., TORONTO, ONTARIO M5B 2B8**

# UNASSEMBLED PARTS

## Steering Wheel

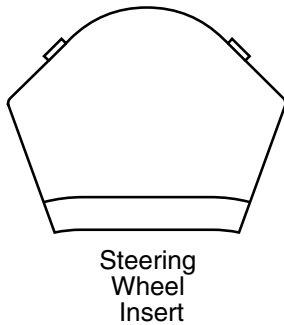
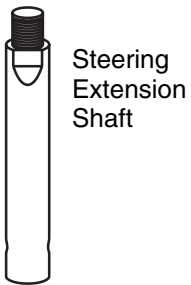
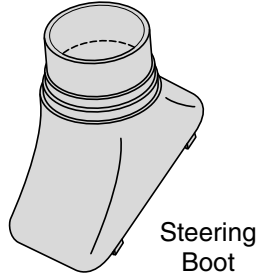
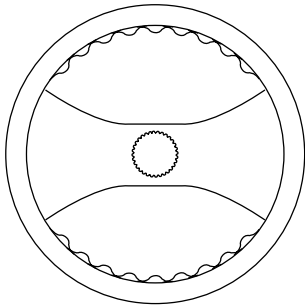

(1) Large Flat Washer

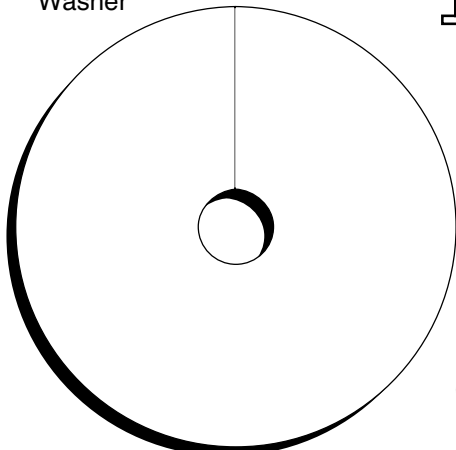
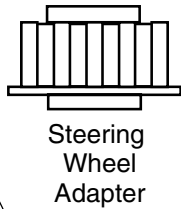

(1) Large Flat Washer

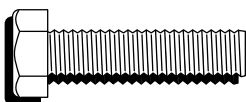
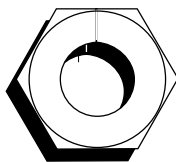

## Seat

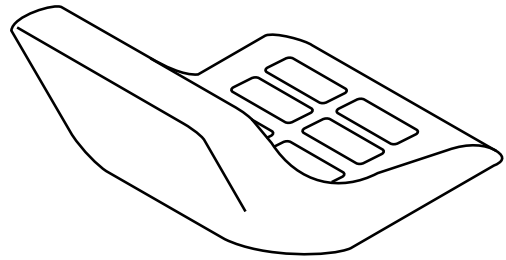

(1) Washer  
17/32 x 1-3/16 x 12 Gauge

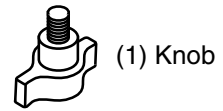

## Battery

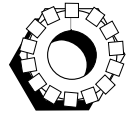
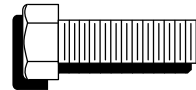

## Keys

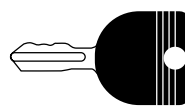

## Slope Sheet

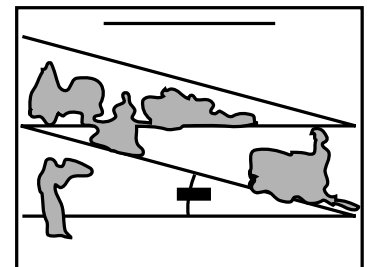

# ASSEMBLY

Your new tractor has been assembled at the factory with exception of those parts left unassembled for shipping purposes. To ensure safe and proper operation of your tractor all parts and hardware you assemble must be tightened securely. Use the correct tools as necessary to insure proper tightness.

## TOOLS REQUIRED FOR ASSEMBLY

A socket wrench set will make assembly easier. Standard wrench sizes are listed.

- |                    |                     |
|--------------------|---------------------|
| (1) 3/4" wrench    | Pliers              |
| (2) 7/16" wrenches | Tire pressure gauge |
|                    | Utility knife       |

When right or left hand is mentioned in this manual, it means when you are in the operating position (seated behind the steering wheel).

## TO REMOVE TRACTOR FROM CARTON

### UNPACK CARTON

- Remove all accessible loose parts and parts cartons from carton.
- Cut along dotted lines on all four panels of carton. Remove end panels and lay side panels flat.
- Check for any additional loose parts or cartons and remove.

## BEFORE REMOVING TRACTOR FROM SKID

### ATTACH STEERING WHEEL (See Fig. 1)

#### ASSEMBLE EXTENSION SHAFT AND BOOT

- Slide extension shaft onto lower steering shaft. Align mounting holes in extension and lower shafts and install 1/4 hex bolt and locknut. Tighten securely.

**IMPORTANT:** TIGHTEN BOLT AND NUT SECURELY TO 10-12 FT. LBS TORQUE.

- Place tabs of steering boot over tab slots in dash and push down to secure.

#### INSTALL STEERING WHEEL

- Position front wheels of the tractor so they are pointing straight forward.
- Remove steering wheel adapter from steering wheel and slide adapter onto steering shaft extension.
- Position steering wheel so cross bars are horizontal (left to right) and slide inside boot and onto adapter.
- Assemble large flat washer, 1/2 hex nut and tighten securely.
- Snap steering wheel insert into center of steering wheel.
- Remove protective materials from tractor hood and grill.

**IMPORTANT:** CHECK FOR AND REMOVE ANY STAPLES IN SKID THAT MAY PUNCTURE TIRES WHERE TRACTOR IS TO ROLL OFF SKID.

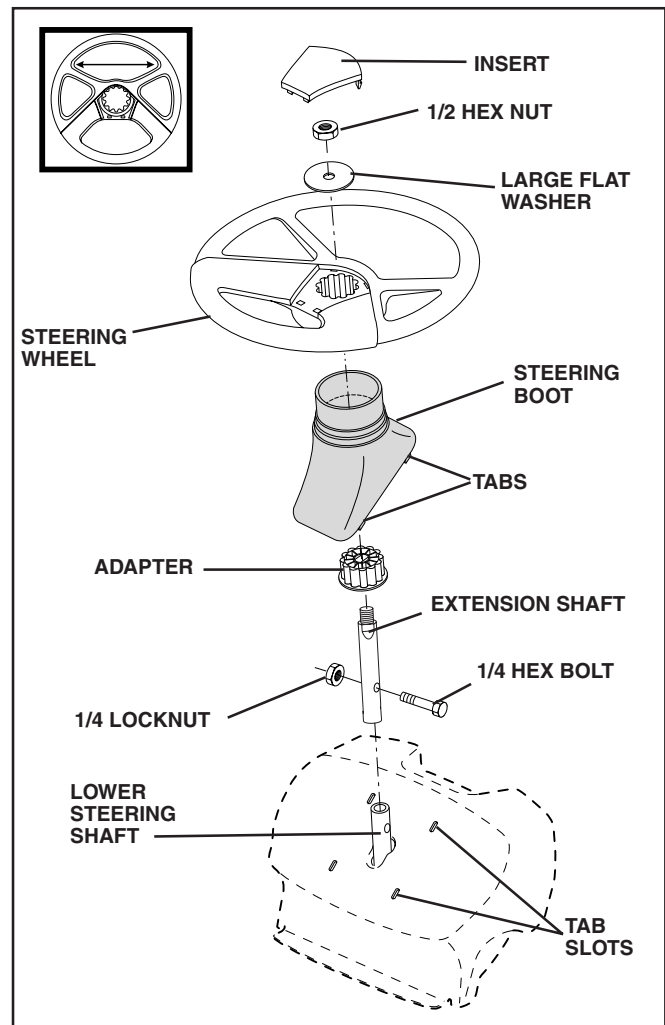

FIG. 1

### INSTALL SEAT (See Fig. 2)

Adjust seat before tightening adjustment knob.

- Remove adjustment knob and flat washer securing seat to cardboard packing and set aside for assembly of seat to tractor.
- Pivot seat upward and remove from the cardboard packing. Remove the cardboard packing and discard.
- Place seat on seat pan so head of shoulder bolt is positioned over large slotted hole in pan.
- Push down on seat to engage shoulder bolt in slot and pull seat towards rear of tractor.
- Pivot seat and pan forward and assemble adjustment knob and flat washer loosely. Do not tighten.
- Lower seat into operating position and sit on seat.
- Slide seat until a comfortable position is reached which allows you to press clutch/brake pedal all the way down.

# ASSEMBLY

- Get off seat without moving its adjusted position.
- Raise seat and tighten adjustment knob securely.

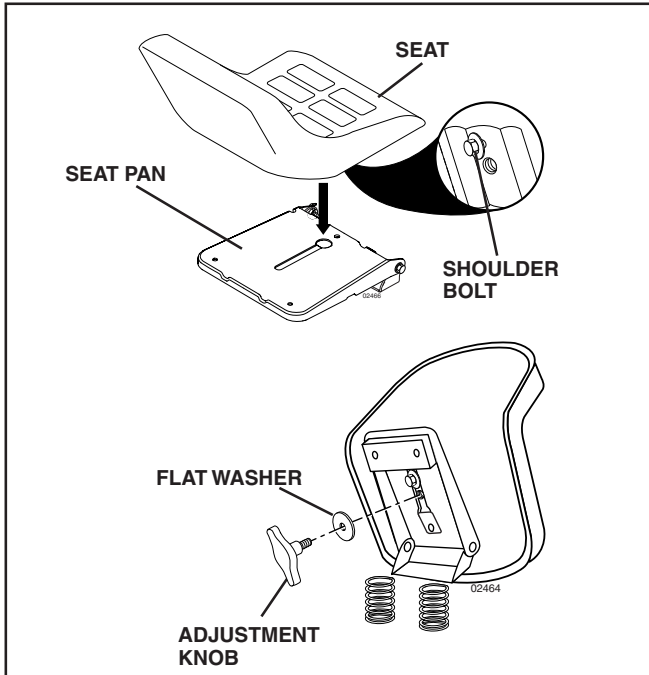

FIG. 2

## HOW TO SET UP YOUR TRACTOR

### CONNECT BATTERY (See Figs. 3 and 4)



**CAUTION:** Do not short battery terminals by allowing a wrench or any other object to contact both terminals at the same time. Before connecting battery, remove metal bracelets, wristwatch bands, rings, etc.

**Positive terminal must be connected first to prevent sparking from accidental grounding.**

- Lift seat pan to raised position.
- Remove terminal protective caps and discard.
- If this battery is put into service after month and year indicated on label (label located between terminals) charge battery for minimum of one hour at 6-10 amps. (See "BATTERY" in the Maintenance section of this manual for charging instructions).
- First connect RED battery cable to positive (+) terminal with hex bolt and keps nut as shown. Tighten securely. Slide terminal cover over terminal.
- Connect BLACK grounding cable to negative (-) terminal with remaining hex bolt and keps nut. Tighten securely.

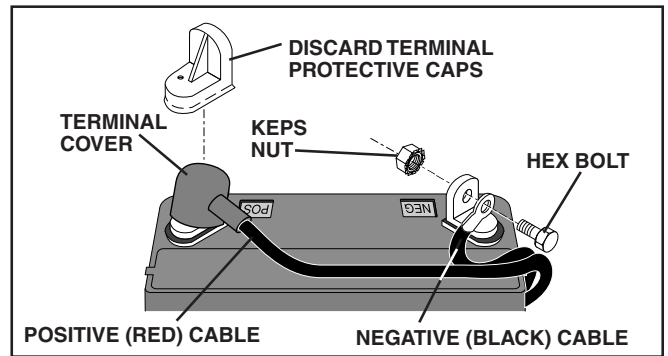

FIG. 3

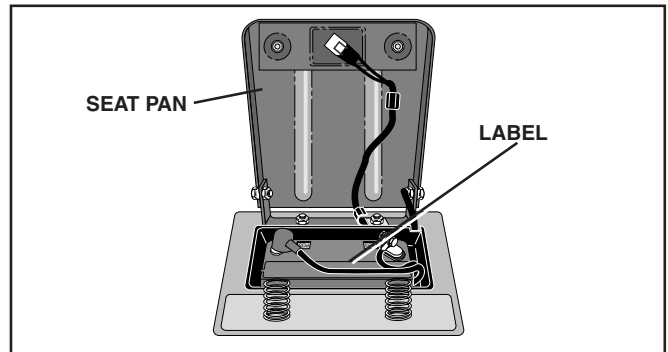

FIG. 4

**NOTE:** You may now roll or drive your tractor off the skid. Follow the appropriate instruction below to remove the tractor from the skid.

### TO ROLL TRACTOR OFF SKID (See Operation section for location and function of controls)

- Press lift lever plunger and raise attachment lift lever to its highest position.
- Release parking brake by depressing clutch/brake pedal.
- Place freewheel control in freewheeling position to disengage transmission (See "TO TRANSPORT" in the Operation section of this manual).
- Roll tractor forward off skid.
- Remove banding holding deflector shield up against tractor.

### TO DRIVE TRACTOR OFF SKID (See Operation section for location and function of controls)

**WARNING:** Before starting, read, understand and follow all instructions in the Operation section of this manual. Be sure tractor is in a well-ventilated area. Be sure the area in front of tractor is clear of other people and objects.

- Be sure all the above assembly steps have been completed.
- Check engine oil level and fill fuel tank with gasoline.
- Place freewheel control in "transmission engaged" position.

# ASSEMBLY

- Sit on seat in operating position, depress clutch/brake pedal and set the parking brake.
- Place motion control lever in neutral (N) position.
- Press lift lever plunger and raise attachment lift lever to its highest position.
- Start the engine. After engine has started, move throttle control to idle position.
- Release parking brake.  
Slowly move the motion control lever forward and slowly drive tractor off skid.
- Apply brake to stop tractor, set parking brake and place motion control lever in neutral position.
- Turn ignition key to "OFF" position.

Continue with the instructions that follow.

## INSTALL MULCHER PLATE (If previously removed) (See Fig. 5)

- Raise and hold deflector shield in upright position.
- Place front of mulcher plate over front of mower deck opening and slide into place, as shown.
- Hook front latch into hole on front of mower deck.
- Hook rear latch into hole on back of mower deck.

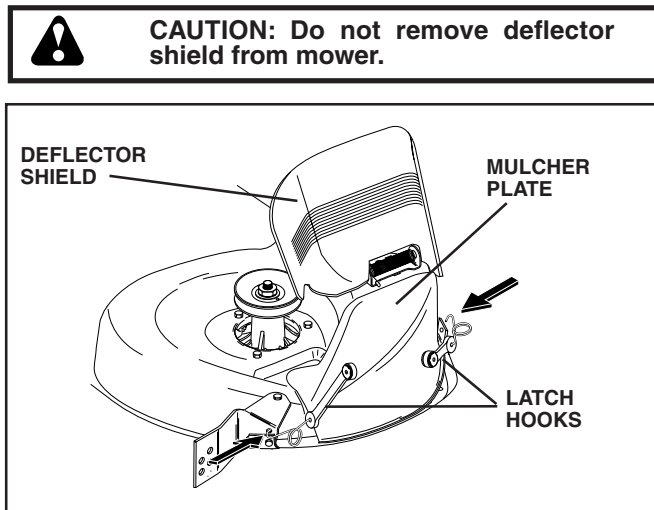

FIG. 5

## TO CONVERT TO BAGGING OR DISCHARGING

Simply remove mulcher plate and store in a safe place. Your mower is now ready for discharging or installation of optional grass catcher accessory.

**NOTE:** It is not necessary to change blades. The mulcher blades are designed for discharging and bagging also.

## CHECK TIRE PRESSURE

The tires on your tractor were overinflated at the factory for shipping purposes. Correct tire pressure is important for best cutting performance.

- Reduce tire pressure to PSI shown in "PRODUCT SPECIFICATIONS" section of this manual.

## CHECK DECK LEVELNESS

For best cutting results, mower housing should be properly leveled. See "TO LEVEL MOWER HOUSING" in the Service and Adjustments section of this manual.

## CHECK FOR PROPER POSITION OF ALL BELTS

See the figures that are shown for replacing motion and mower blade drive belts in the Service and Adjustments section of this manual. Verify that the belts are routed correctly.

## CHECK BRAKE SYSTEM

After you learn how to operate your tractor, check to see that the brake is properly adjusted. See "TO ADJUST BRAKE" in the Service and Adjustments section of this manual.

## ✓ CHECKLIST

*BEFORE YOU OPERATE AND ENJOY YOUR NEW TRACTOR, WE WISH TO ASSURE THAT YOU RECEIVE THE BEST PERFORMANCE AND SATISFACTION FROM THIS QUALITY PRODUCT.*

*PLEASE REVIEW THE FOLLOWING CHECKLIST:*

- ✓ All assembly instructions have been completed.
- ✓ No remaining loose parts in carton.
- ✓ Battery is properly prepared and charged. (Minimum 1 hour at 6 amps).
- ✓ Seat is adjusted comfortably and tightened securely.
- ✓ All tires are properly inflated. (For shipping purposes, the tires were overinflated at the factory).
- ✓ Be sure mower deck is properly leveled side-to-side/front-to-rear for best cutting results. (Tires must be properly inflated for leveling).
- ✓ Check mower and drive belts. Be sure they are routed properly around pulleys and inside all belt keepers.
- ✓ Check wiring. See that all connections are still secure and wires are properly clamped.
- ✓ Before driving tractor, be sure freewheel control is in drive position.

*WHILE LEARNING HOW TO USE YOUR TRACTOR, PAY EXTRA ATTENTION TO THE FOLLOWING IMPORTANT ITEMS:*

- ✓ Engine oil is at proper level.
- ✓ Fuel tank is filled with fresh, clean, regular unleaded gasoline.
- ✓ Become familiar with all controls - their location and function. Operate them before you start the engine.
- ✓ Be sure brake system is in safe operating condition.
- ✓ It is important to purge the transmission before operating your tractor for the first time. Follow proper starting and transmission purging instructions (See "TO START ENGINE" and "PURGE TRANSMISSION" in the Operation section of this manual).



# OPERATION

These symbols may appear on your tractor or in literature supplied with the product. Learn and understand their meaning.

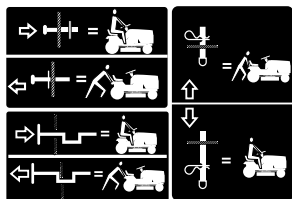
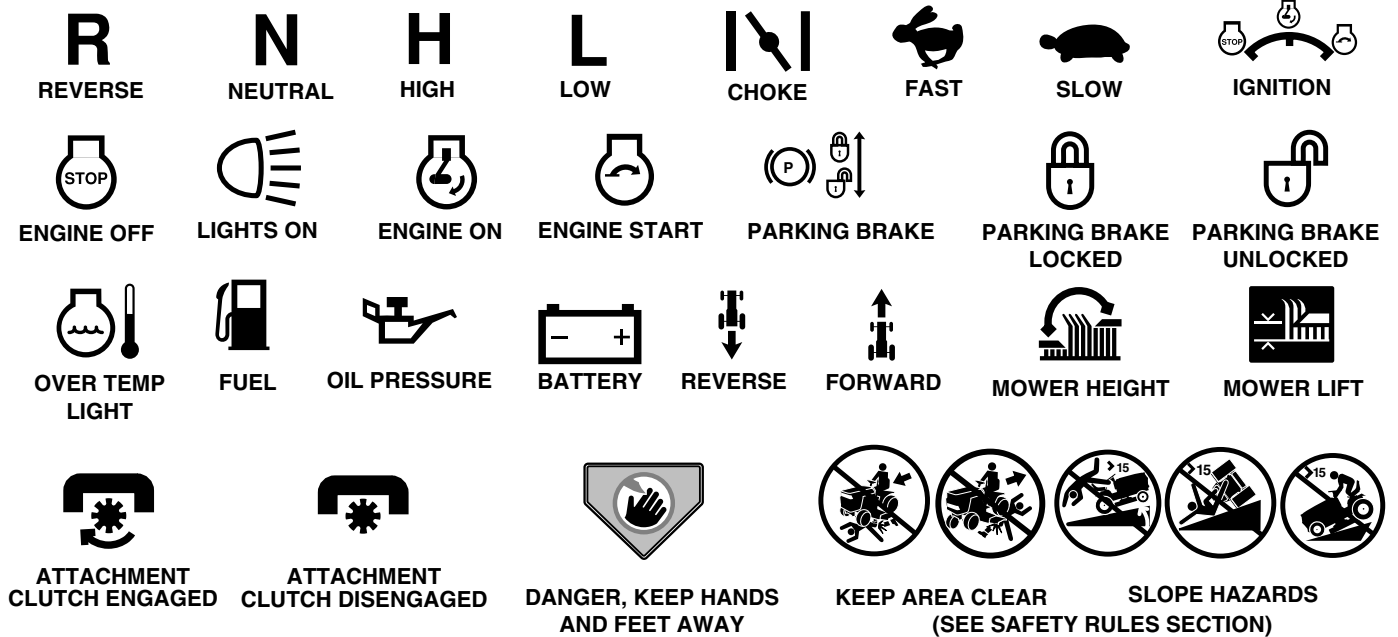

**FREE WHEEL**  
(Automatic Models only)



Failure to follow instructions could result in serious injury or death. The safety alert symbol is used to identify safety information about hazards which can result in death, serious injury and/or property damage.



**DANGER** indicates a hazard which, if not avoided, will result in death or serious injury.



**WARNING** indicates a hazard which, if not avoided, could result in death or serious injury.



**CAUTION** indicates a hazard which, if not avoided, might result in minor or moderate injury.

**CAUTION** when used **without** the alert symbol, indicates a situation that **could result in damage to the tractor and/or engine.**



**HOT SURFACES** indicates a hazard which, if not avoided, could result in death, serious injury and/or property damage.



**FIRE** indicates a hazard which, if not avoided, could result in death, serious injury and/or property damage.

---

# OPERATION

---

## KNOW YOUR TRACTOR

### READ THIS OWNER'S MANUAL AND SAFETY RULES BEFORE OPERATING YOUR TRACTOR

Compare the illustrations with your tractor to familiarize yourself with the locations of various controls and adjustments. Save this manual for future reference.

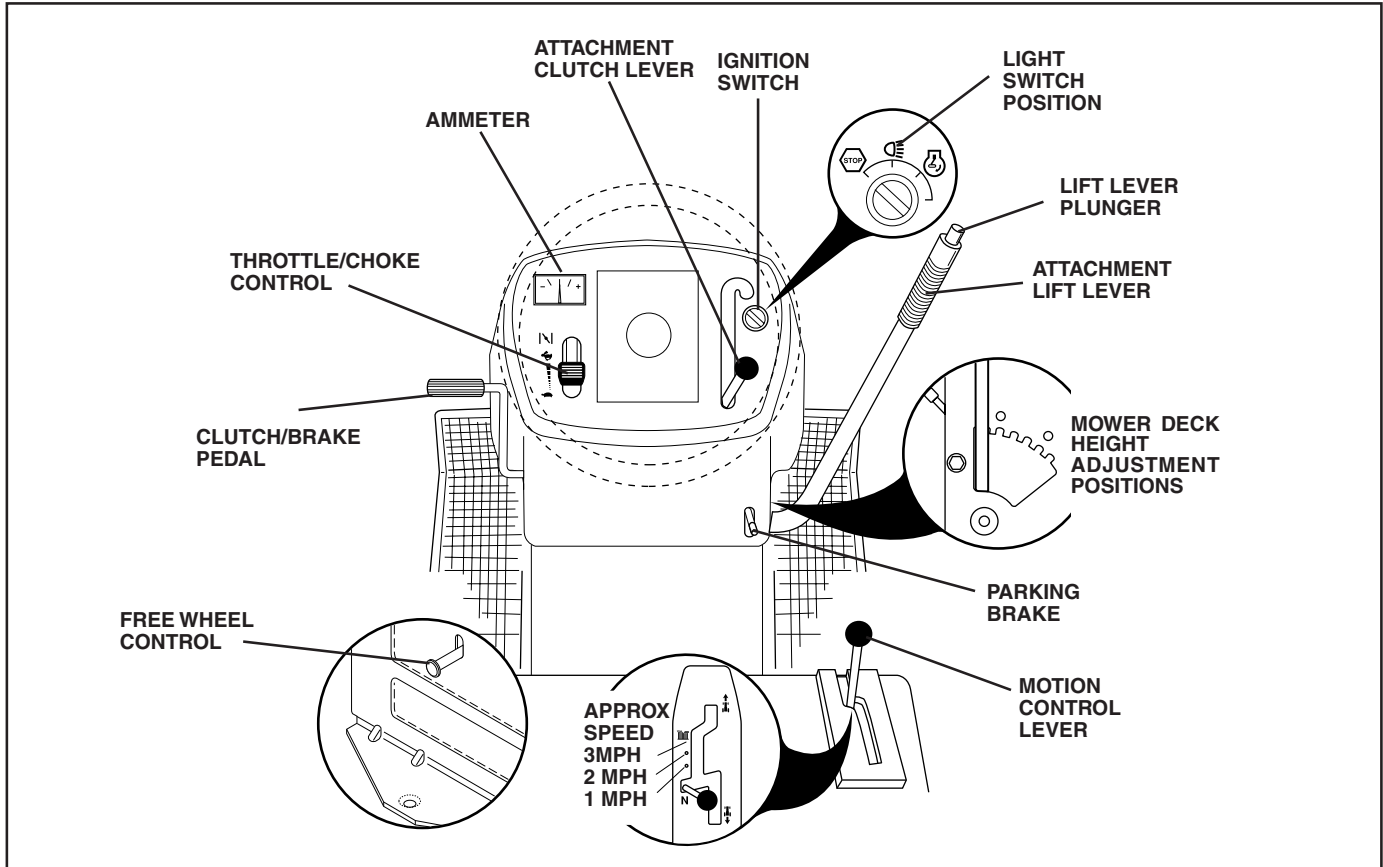

FIG. 6

---

Our tractors conform to the safety standards of the American National Standards Institute.

---

**ATTACHMENT CLUTCH LEVER** - Used to engage the mower blades, or other attachments mounted to your tractor.

**LIGHT SWITCH POSITION** - Turns the headlights on and off.

**THROTTLE/CHOKE CONTROL** - Used for starting and controlling engine speed.

**CLUTCH/BRAKE PEDAL** - Used for declutching and braking the tractor and starting the engine.

**PARKING BRAKE** - Locks clutch/brake pedal into the brake position.

**FREEWHEEL CONTROL** - Disengages transmission for pushing or slowly towing the tractor with the engine off.

**AMMETER** - Indicates charging (+) or discharging (-) of battery.

**MOTION CONTROL LEVER** - Selects the speed and direction of tractor.

**ATTACHMENT LIFT LEVER** - Used to raise, lower, and adjust the mower deck or other attachments mounted to your tractor.

**LIFT LEVER PLUNGER** - Used to release attachment lift lever when changing its position.

**IGNITION SWITCH** - Used for starting and stopping the engine.

# OPERATION



The operation of any tractor can result in foreign objects thrown into the eyes, which can result in severe eye damage. Always wear safety glasses or eye shields while operating your tractor or performing any adjustments or repairs. We recommend a wide vision safety mask over spectacles or standard safety glasses.

## HOW TO USE YOUR TRACTOR

### TO SET PARKING BRAKE (See Fig. 7)

Your tractor is equipped with an operator presence sensing switch. When engine is running, any attempt by the operator to leave the seat without first setting the parking brake will shut off the engine.

- Depress clutch/brake pedal into full "BRAKE" position and hold.
- Place parking brake lever in "ENGAGED" position and release pressure from clutch/brake pedal. Pedal should remain in "BRAKE" position. Make sure parking brake will hold tractor secure.

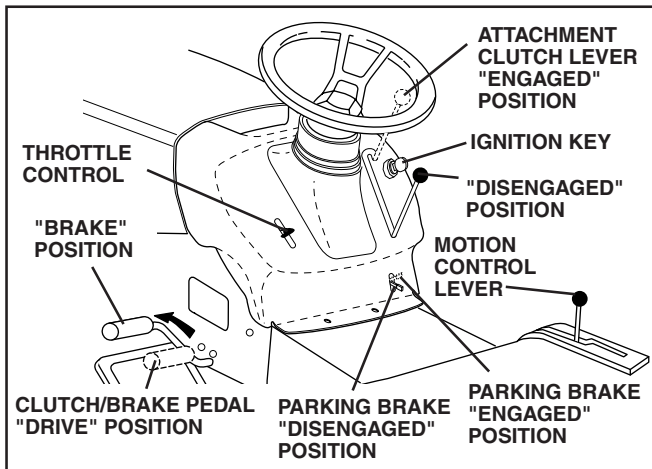

FIG. 7

### STOPPING (See Fig. 7)

#### MOWER BLADES -

- To stop mower blades, move attachment clutch lever to "DISENGAGED" position.

#### GROUND DRIVE -

- To stop ground drive, depress clutch/brake pedal into full "BRAKE" position.
- Move motion control lever to neutral (N) position.

**IMPORTANT:** THE MOTION CONTROL LEVER DOES NOT RETURN TO NEUTRAL (N) POSITION WHEN THE CLUTCH/BRAKE PEDAL IS DEPRESSED.

#### ENGINE -

- Move throttle control to slow position.

**NOTE:** Failure to move throttle control to slow position and allowing engine to idle before stopping may cause engine to "backfire".

- Turn ignition key to "OFF" position and remove key. Always remove key when leaving tractor to prevent unauthorized use.
- Never use choke to stop engine.

**IMPORTANT:** LEAVING THE IGNITION SWITCH IN ANY POSITION OTHER THAN "OFF" WILL CAUSE THE BATTERY TO BE DISCHARGED, (DEAD).

**NOTE:** Under certain conditions when tractor is standing idle with the engine running, hot engine exhaust gases may cause "browning" of grass. To eliminate this possibility, always stop engine when stopping tractor on grass areas.



**CAUTION:** Always stop tractor completely, as described above, before leaving the operator's position; to empty grass catcher, etc.

### TO USE THROTTLE CONTROL (See Fig. 7)

Always operate engine at full throttle.

- Operating engine at less than full throttle reduces the battery charging rate.
- Full throttle offers the best bagging and mower performance.

### TO MOVE FORWARD AND BACKWARD (See Fig. 7)

The direction and speed of movement is controlled by the motion control lever.

- Start tractor with motion control lever in neutral (N) position.
- Release parking brake.
- Slowly move motion control lever to desired position.

### TO ADJUST MOWER CUTTING HEIGHT (See Fig. 7)

The position of the attachment lift lever determines the cutting height.

- Grasp lift lever.
- Press plunger with thumb and move lever to desired position.

The cutting height range is approximately 1-1/2 to 4". The heights are measured from the ground to the blade tip with the engine not running. These heights are approximate and may vary depending upon soil conditions, height of grass and types of grass being mowed.

- The average lawn should be cut to approximately 2-1/2 inches during the cool season and to over 3 inches during hot months. For healthier and better looking lawns, mow often and after moderate growth.
- For best cutting performance, grass over 6 inches in height should be mowed twice. Make the first cut relatively high; the second to desired height.

# OPERATION

## TO ADJUST GAUGE WHEELS (See Fig. 8)

Gauge wheels are properly adjusted when they are slightly off the ground when mower is at the desired cutting height in operating position. Gauge wheels then keep the deck in proper position to help prevent scalping in most terrain conditions.

**NOTE:** Adjust gauge wheels with tractor on a flat level surface.

- Adjust mower to desired cutting height (See "TO ADJUST MOWER CUTTING HEIGHT" in the Operation section of this manual).
- With mower in desired height of cut position, gauge wheels should be assembled so they are slightly off the ground. Install gauge wheel in appropriate hole with shoulder bolt, 3/8 washer, and 3/8-16 locknut and tighten securely.
- Repeat for opposite side installing gauge wheel in same adjustment hole.

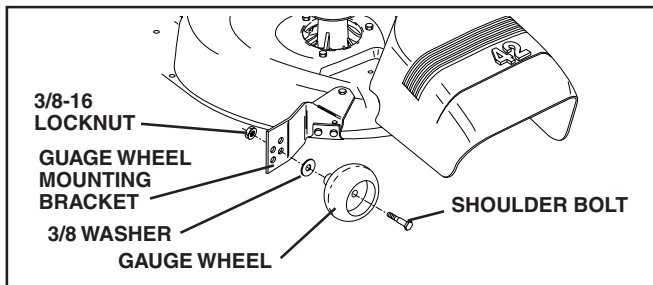

FIG. 8

## TO OPERATE MOWER (See Fig. 9)

Your tractor is equipped with an operator presence sensing switch. Any attempt by the operator to leave the seat with the engine running and the attachment clutch engaged will shut off the engine.

- Select desired height of cut.
- Start mower blades by engaging attachment clutch control.
- TO STOP MOWER BLADES - disengage attachment clutch control.

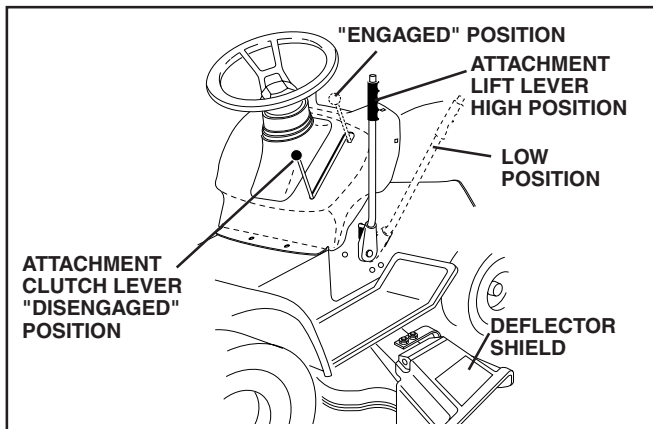
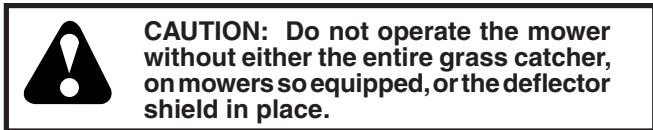

FIG. 9

## TO OPERATE ON HILLS



**WARNING:** Do not drive up or down hills with slopes greater than 15° and do not drive across any slope.

- Choose the slowest speed before starting up or down hills.
- Avoid stopping or changing speed on hills.
- If slowing is necessary, move throttle control lever to slower position.
- If stopping is absolutely necessary, push clutch/brake pedal quickly to brake position and engage parking brake.
- Move motion control lever to neutral (N) position.

**IMPORTANT:** THE MOTION CONTROL LEVER DOES NOT RETURN TO NEUTRAL (N) POSITION WHEN THE CLUTCH/ BRAKE PEDAL IS DEPRESSED.

- To restart movement, slowly release parking brake and clutch/brake pedal.
- Slowly move motion control lever to slowest setting.
- Make all turns slowly.

## TO TRANSPORT (See Figs. 6 and 10)

When pushing or towing your tractor, be sure to disengage transmission by placing freewheel control in freewheeling position. Free wheel control is located at the rear drawbar of tractor.

- Raise attachment lift to highest position with attachment lift control.
- Pull freewheel control out and down into the slot and release so it is held in the disengaged position.
- Do not push or tow tractor at more than two (2) MPH.
- To reengage transmission, reverse above procedure.

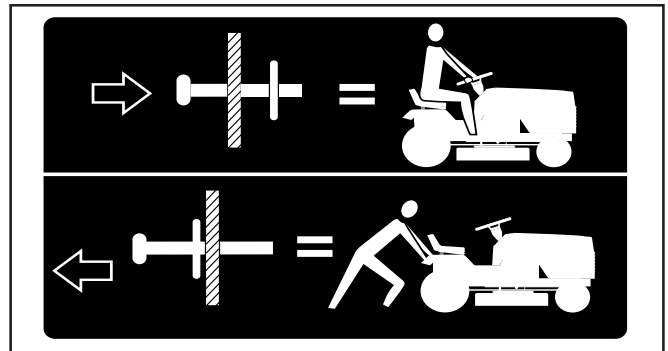

FIG. 10

**NOTE:** To protect hood from damage when transporting your tractor on a truck or a trailer, be sure hood is closed and secured to tractor. Use an appropriate means of tying hood to tractor (rope, cord, etc.).

## TOWING CARTS AND OTHER ATTACHMENTS

Tow only the attachments that are recommended by and comply with specifications of the manufacturer of your tractor. Use common sense when towing. Too heavy of a load, while on a slope, is dangerous. Tires can lose traction with the ground and cause you to lose control of your tractor.

# OPERATION

## BEFORE STARTING THE ENGINE

### CHECK ENGINE OIL LEVEL

- The engine in your tractor has been shipped, from the factory, already filled with summer weight oil.
- Check engine oil with tractor on level ground.
- Remove oil fill cap/dipstick and wipe clean, reinsert the dipstick and screw cap tight, wait for a few seconds, remove and read oil level. If necessary, add oil until "FULL" mark on dipstick is reached. Do not overfill.
- For cold weather operation you should change oil for easier starting (See "OIL VISCOSITY CHART" in the Maintenance section of this manual).
- To change engine oil, see the Maintenance section in this manual.

### ADD GASOLINE

- Fill fuel tank to bottom of filler neck. Do not overfill. Use fresh, clean, regular unleaded gasoline with a minimum of 87 octane. (Use of leaded gasoline will increase carbon and lead oxide deposits and reduce valve life). Do not mix oil with gasoline. Purchase fuel in quantities that can be used within 30 days to assure fuel freshness.



**CAUTION:** Wipe off any spilled oil or fuel. Do not store, spill or use gasoline near an open flame.

**IMPORTANT:** WHEN OPERATING IN TEMPERATURES BELOW 32°F (0°C), USE FRESH, CLEAN WINTER GRADE GASOLINE TO HELP INSURE GOOD COLD WEATHER STARTING.

**CAUTION:** Alcohol blended fuels (called gasohol or using ethanol or methanol) can attract moisture which leads to separation and formation of acids during storage. Acidic gas can damage the fuel system of an engine while in storage. To avoid engine problems, the fuel system should be emptied before storage of 30 days or longer. Drain the gas tank, start the engine and let it run until the fuel lines and carburetor are empty. Use fresh fuel next season. See Storage Instructions for additional information. Never use engine or carburetor cleaner products in the fuel tank or permanent damage may occur.

### TO START ENGINE (See Fig. 6)

When starting the engine for the first time or if the engine has run out of fuel, it will take extra cranking time to move fuel from the tank to the engine.

- Be sure freewheel control is in the transmission engaged position.
- Sit on seat in operating position, depress clutch/brake pedal and set parking brake.
- Place motion control lever in neutral (N) position.
- Move attachment clutch to "DISENGAGED" position.
- Move throttle control to fast position
- Pull choke control out for a cold engine start attempt. For a warm engine start attempt the choke control may not be needed.

**NOTE:** Before starting, read the warm and cold starting procedures below.

- Insert key into ignition and turn key clockwise to "START" position and release key as soon as engine starts. Do not run starter continuously for more than fifteen seconds per minute. If the engine does not start after several attempts, push choke control in, wait a few minutes and try again. If engine still does not start, pull the choke control out and retry.

### WARM WEATHER STARTING (50° F and above)

- When engine starts, slowly push choke control in until the engine begins to run smoothly. If the engine starts to run roughly, pull the choke control out slightly for a few seconds and then continue to push the control in slowly.
- The attachments and ground drive can now be used. If the engine does not accept the load, restart the engine and allow it to warm up for one minute using the choke as described above.

### COLD WEATHER STARTING (50° F and below)

- When engine starts, slowly push choke control in until the engine begins to run smoothly. Continue to push the choke control in small steps allowing the engine to accept small changes in speed and load, until the choke control is fully in. If the engine starts to run roughly, pull the choke control out slightly for a few seconds and then continue to push the control in slowly. This may require an engine warm-up period from several seconds to several minutes, depending on the temperature.

### AUTOMATIC TRANSMISSION WARM UP

- Before driving the unit in cold weather, the transmission should be warmed up as follows:
  - Be sure the tractor is on level ground.
  - Place the motion control lever in neutral. Release the parking brake and let the clutch/brake slowly return to operating position.
  - Allow one minute for transmission to warm up. This can be done during the engine warm up period.
- The attachments can be used during the engine warm-up period after the transmission has been warmed up and may require the choke control be pulled out slightly.

**NOTE:** If at a high altitude (above 3000 feet) or in cold temperatures (below 32 F) the carburetor fuel mixture may need to be adjusted for best engine performance. See "TO ADJUST CARBURETOR" in the Service and Adjustments section of this manual.

### PURGE TRANSMISSION



**CAUTION:** Never engage or disengage freewheel lever while the engine is running.

To ensure proper operation and performance, it is recommended that the transmission be purged before operating tractor for the first time. This procedure will remove any trapped air inside the transmission which may have developed during shipping of your tractor.

**IMPORTANT:** SHOULD YOUR TRANSMISSION REQUIRE REMOVAL FOR SERVICE OR REPLACEMENT, IT SHOULD BE PURGED AFTER REINSTALLATION BEFORE OPERATING THE TRACTOR.

# OPERATION

- Place tractor safely on level surface with engine off and parking brake set.
- Disengage transmission by placing freewheel control in freewheeling position (See “TO TRANSPORT” in this section of manual).
- Sitting in the tractor seat, start engine. After the engine is running, move throttle control to slow position. With motion control lever in neutral (N) position, slowly disengage clutch/brake pedal.
- Move motion control lever to full forward position and hold for five (5) seconds. Move lever to full reverse position and hold for five (5) seconds. Repeat this procedure three (3) times.

**NOTE:** During this procedure there will be no movement of drive wheels. The air is being removed from hydraulic drive system.

- Move motion control lever to neutral (N) position. Shut-off engine and set parking brake.
- Engage transmission by placing freewheel control in driving position (See “TO TRANSPORT” in this section of manual).
- Sitting in the tractor seat, start engine. After the engine is running, move throttle control to half (1/2) speed. With motion control lever in neutral (N) position, slowly disengage clutch/brake pedal.
- Slowly move motion control lever forward, after the tractor moves approximately five (5) feet, slowly move motion control lever to reverse position. After the tractor moves approximately five (5) feet return the motion control lever to the neutral (N) position. Repeat this procedure with the motion control lever three (3) times.
- Your tractor is now purged and now ready for normal operation.

## MOWING TIPS

- Mower should be properly leveled for best mowing performance. See “TO LEVEL MOWER HOUSING” in the Service and Adjustments section of this manual.
- The left hand side of mower should be used for trimming.
- Drive so that clippings are discharged onto the area that has been cut. Have the cut area to the right of the machine. This will result in a more even distribution of clippings and more uniform cutting.
- When mowing large areas, start by turning to the right so that clippings will discharge away from shrubs, fences, driveways, etc. After one or two rounds, mow in the opposite direction making left hand turns until finished (See Fig. 11).

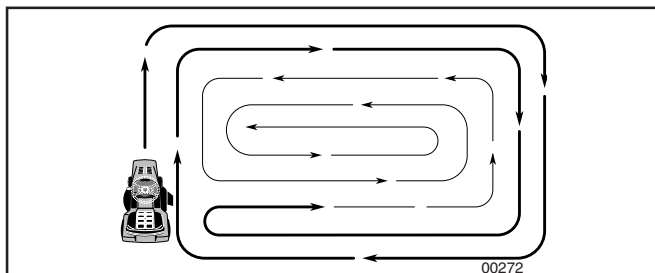

FIG. 11

- If grass is extremely tall, it should be mowed twice to reduce load and possible fire hazard from dried clippings. Make first cut relatively high; the second to the desired height.
- Do not mow grass when it is wet. Wet grass will plug mower and leave undesirable clumps. Allow grass to dry before mowing.
- **Always operate engine at full throttle when mowing** to assure better mowing performance and proper discharge of material. Regulate ground speed by selecting a low enough gear to give the mower cutting performance as well as the quality of cut desired.
- When operating attachments, select a ground speed that will suit the terrain and give best performance of the attachment being used.

## MULCHING MOWING TIPS

**IMPORTANT:** FOR BEST PERFORMANCE, KEEP MOWER HOUSING FREE OF BUILT-UP GRASS AND TRASH. CLEAN AFTER EACH USE.

- The special mulching blade will recut the grass clippings many times and reduce them in size so that as they fall onto the lawn they will disperse into the grass and not be noticed. Also, the mulched grass will biodegrade quickly to provide nutrients for the lawn. Always mulch with your highest engine (blade) speed as this will provide the best recutting action of the blades.
- Avoid cutting your lawn when it is wet. Wet grass tends to form clumps and interferes with the mulching action. The best time to mow your lawn is the early afternoon. At this time the grass has dried and the newly cut area will not be exposed to the direct sun.
- For best results, adjust the mower cutting height so that the mower cuts off only the top one-third of the grass blades (See Fig. 12). For extremely heavy mulching, reduce your width of cut on each pass and mow slowly.

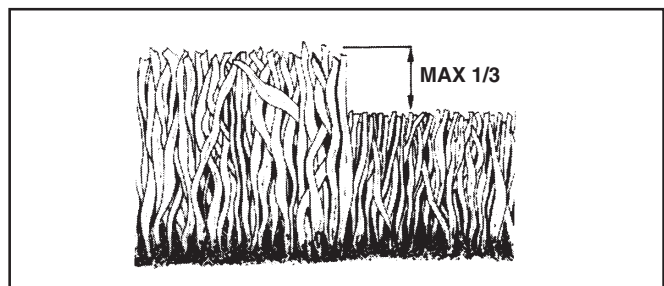

FIG. 12

- Certain types of grass and grass conditions may require that an area be mulched a second time to completely hide the clippings. When doing a second cut, mow across or perpendicular to the first cut path.
- Change your cutting pattern from week to week. Mow north to south one week then change to east to west the next week. This will help prevent matting and graining of the lawn.

# MAINTENANCE

MAINTENANCE SCHEDULE		BEFORE EACH USE							SERVICE DATES			
		BEFORE EACH USE	EVERY 8 HOURS	EVERY 25 HOURS	EVERY 50 HOURS	EVERY 100 HOURS	EVERY SEASON	BEFORE STORAGE				
TRACTOR	Check Brake Operation	✓	✓									
	Check Tire Pressure	✓	✓									
	Check Operator Presence and Interlock Systems	✓										
	Check for Loose Fasteners	✓				✓ <sub>5</sub>		✓				
	Sharpen/Replace Mower Blades			✓ <sub>3</sub>								
	Lubrication Chart			✓				✓				
	Check Battery Level			✓ <sub>4</sub>								
	Clean Battery and Terminals			✓					✓			
	Check Transaxle Cooling			✓								
	Check V-Belts					✓						
	ENGINE	Check Engine Oil Level	✓	✓								
Change Engine Oil (with oil filter)					✓ <sub>1,2</sub>			✓				
Change Engine Oil (without oil filter)				✓ <sub>1,2</sub>				✓				
Clean Air Filter				✓ <sub>2</sub>								
Clean Air Screen				✓ <sub>2</sub>								
Inspect Muffler/Spark Arrester					✓							
Replace Oil Filter (If equipped)						✓ <sub>1,2</sub>						
Clean Engine Cooling Fins						✓ <sub>2</sub>						
Replace Spark Plug						✓		✓				
Replace Air Filter Paper Cartridge						✓ <sub>2</sub>						
Replace Fuel Filter								✓				

1 - Change more often when operating under a heavy load or in high ambient temperatures.  
 2 - Service more often when operating in dirty or dusty conditions.

3 - Replace blades more often when mowing in sandy soil.  
 4 - Not required if equipped with maintenance-free battery.  
 5 - Tighten front axle pivot bolt to 35 ft.-lbs. maximum. Do not overtighten.

maint\_sch-tractor.new.1

## GENERAL RECOMMENDATIONS

The warranty on this tractor does not cover items that have been subjected to operator abuse or negligence. To receive full value from the warranty, operator must maintain tractor as instructed in this manual.

Some adjustments will need to be made periodically to properly maintain your tractor.

All adjustments in the Service and Adjustments section of this manual should be checked at least once each season.

- Once a year you should replace the spark plug, clean or replace air filter, and check blades and belts for wear. A new spark plug and clean air filter assure proper air-fuel mixture and help your engine run better and last longer.

## BEFORE EACH USE

- Check engine oil level.
- Check brake operation.
- Check tire pressure.
- Check operator presence and interlock systems for proper operation.
- Check for loose fasteners.

## LUBRICATION CHART

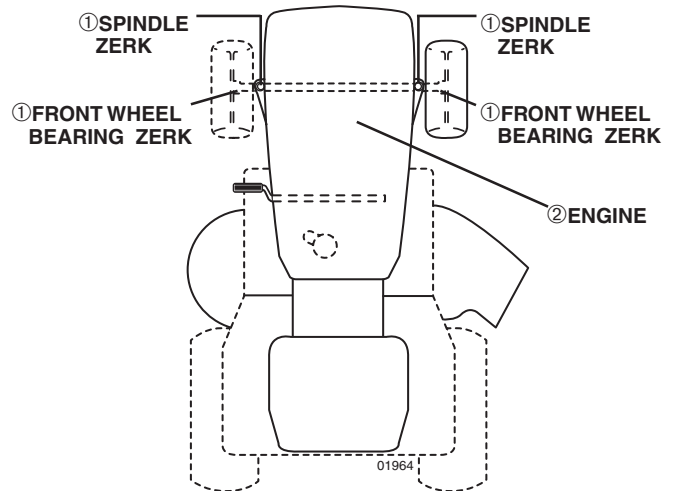

- ① GENERAL PURPOSE GREASE
- ② REFER TO MAINTENANCE "ENGINE" SECTION

**IMPORTANT:** DO NOT OIL OR GREASE THE PIVOT POINTS WHICH HAVE SPECIAL NYLON BEARINGS. VISCOUS LUBRICANTS WILL ATTRACT DUST AND DIRT THAT WILL SHORTEN THE LIFE OF THE SELF-LUBRICATING BEARINGS. IF YOU FEEL THEY MUST BE LUBRICATED, USE ONLY A DRY, POWDERED GRAPHITE TYPE LUBRICANT SPARINGLY.

# MAINTENANCE

## TRACTOR

Always observe safety rules when performing any maintenance.

## BRAKE OPERATION

If tractor requires more than six (6) feet stopping distance at high speed in highest gear, then brake must be adjusted. (See "TO ADJUST BRAKE" in the Service and Adjustments section of this manual).

## TIRES

- Maintain proper air pressure in all tires (See "PRODUCT SPECIFICATIONS" section of this manual).
- Keep tires free of gasoline, oil, or insect control chemicals which can harm rubber.
- Avoid stumps, stones, deep ruts, sharp objects and other hazards that may cause tire damage.

**NOTE:** To seal tire punctures and prevent flat tires due to slow leaks, tire sealant may be purchased from your local parts dealer. Tire sealant also prevents tire dry rot and corrosion.

## OPERATOR PRESENCE SYSTEM

Be sure operator presence and interlock systems are working properly. If your tractor does not function as described, repair the problem immediately.

- The engine should not start unless the brake pedal is fully depressed and attachment clutch control is in the disengaged position.
- When the engine is running, any attempt by the operator to leave the seat without first setting the parking brake should shut off the engine.
- When the engine is running and the attachment clutch is engaged, any attempt by the operator to leave the seat should shut off the engine.
- The attachment clutch should never operate unless the operator is in the seat.

## BLADE CARE

For best results mower blades must be kept sharp. Replace bent or damaged blades.

## BLADE REMOVAL (See Fig. 13)

- Raise mower to highest position to allow access to blades.
- Remove blade bolt, lock washer and flat washer securing blade.
- Install new or resharpened blade with trailing edge up towards deck as shown.

**IMPORTANT:** TO ENSURE PROPER ASSEMBLY, CENTER HOLE IN BLADE MUST ALIGN WITH STAR ON MANDREL ASSEMBLY.

- Reassemble blade bolt, lock washer and flat washer in exact order as shown.
- Tighten blade bolt securely (27-35 Ft. Lbs. torque).

**IMPORTANT:** BLADE BOLT IS GRADE 8 HEAT TREATED.

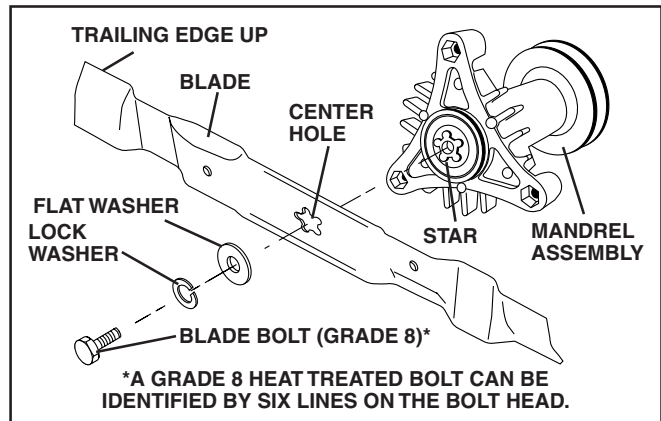

FIG. 13

## TO SHARPEN BLADE (See Fig. 14)

**NOTE:** We do not recommend sharpening blade - but if you do, be sure the blade is balanced.

Care should be taken to keep the blade balanced. An unbalanced blade will cause excessive vibration and eventual damage to mower and engine.

- The blade can be sharpened with a file or on a grinding wheel. Do not attempt to sharpen while on the mower.
- To check blade balance, you will need a 5/8" diameter steel bolt, pin, or a cone balancer. (When using a cone balancer, follow the instructions supplied with balancer).

**NOTE:** Do not use a nail for balancing blade. The lobes of the center hole may appear to be centered, but are not.

- Slide blade on to an unthreaded portion of the steel bolt or pin and hold the bolt or pin parallel with the ground. If blade is balanced, it should remain in a horizontal position. If either end of the blade moves downward, sharpen the heavy end until the blade is balanced.

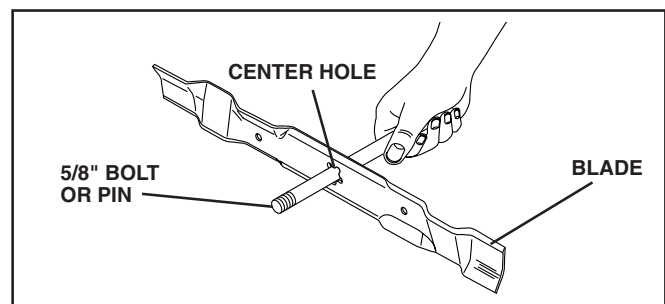

FIG. 14

## BATTERY

Your tractor has a battery charging system which is sufficient for normal use. However, periodic charging of the battery with an automotive charger will extend its life.

- Keep battery and terminals clean.
- Keep battery bolts tight.
- Keep small vent holes open.
- Recharge at 6-10 amperes for 1 hour.



# MAINTENANCE

**NOTE:** The original equipment battery on your tractor is maintenance free. Do not attempt to open or remove caps or covers. Adding or checking level of electrolyte is not necessary.

## TO CLEAN BATTERY AND TERMINALS

Corrosion and dirt on the battery and terminals can cause the battery to “leak” power.

- Disconnect BLACK battery cable first then RED battery cable and remove battery from tractor.
- Rinse the battery with plain water and dry.
- Clean terminals and battery cable ends with wire brush until bright.
- Coat terminals with grease or petroleum jelly.
- Reinstall battery (See “CONNECT BATTERY” in the Assembly section of this manual).

## V-BELTS

Check V-belts for deterioration and wear after 100 hours of operation and replace if necessary. The belts are not adjustable. Replace belts if they begin to slip from wear.

## TRANSAXLE COOLING

The transmission fan and cooling fins should be kept clean to assure proper cooling.

Do not attempt to clean fan or transmission while engine is running or while the transmission is hot. To prevent possible damage to seals, do not use high pressure water or steam to clean transaxle.

- Inspect cooling fan to be sure fan blades are intact and clean.
- Inspect cooling fins for dirt, grass clippings and other materials. To prevent damage to seals, do not use compressed air or high pressure sprayer to clean cooling fins.

## TRANSAXLE PUMP FLUID

The transaxle was sealed at the factory and fluid maintenance is not required for the life of the transaxle. Should the transaxle ever leak or require servicing, contact your nearest authorized service center/department.

## ENGINE

### LUBRICATION

Only use high quality detergent oil rated with API service classification SF-SJ. Select the oil's SAE viscosity grade according to your expected operating temperature. When operating in temperatures below 0° F (-18° C) synthetic oil must be used.

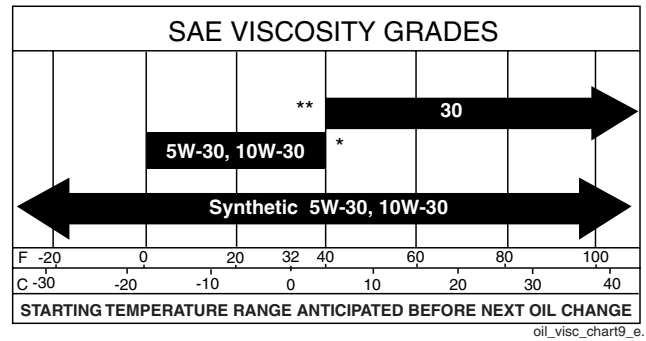

FIG. 15

\* **CAUTION:** Air cooled engines run hotter than automotive engines. The use of non-synthetic multi-viscosity oils (5W30, 10W30 etc.) in temperatures above 40° F (4° C) will result in higher than normal oil consumption. When using a multi-viscosity oil, check oil level more frequently.

\*\* **CAUTION:** SAE 30 oil, if used below 40° F (4° C), will result in hard starting and possible engine bore damage due to inadequate lubrication.



**NOTE:** Synthetic oil meeting ILSAC GF-2, API certification mark and API service symbol (shown at left) with "SJ/CF ENERGY CONSERVING" or higher, is an acceptable oil at all temperatures. **Use of synthetic oil does not alter required oil change intervals.**

Change the oil after every 50 hours of operation or at least once a year if the tractor is not used for 50 hours in one year.

Check the crankcase oil level before starting the engine and after each eight (8) hours of operation. Tighten oil fill cap/dipstick securely each time you check the oil level.

## TO CHANGE ENGINE OIL (See Figs. 15 and 16)

Determine temperature range expected before oil change. All oil must meet API service classification SF-SJ.

- Be sure tractor is on level surface.
- Oil will drain more freely when warm.
- Catch oil in a suitable container.
- Remove oil fill cap/dipstick. Be careful not to allow dirt to enter the engine when changing oil.
- Remove yellow cap from end of drain valve and install the drain tube onto the fitting.

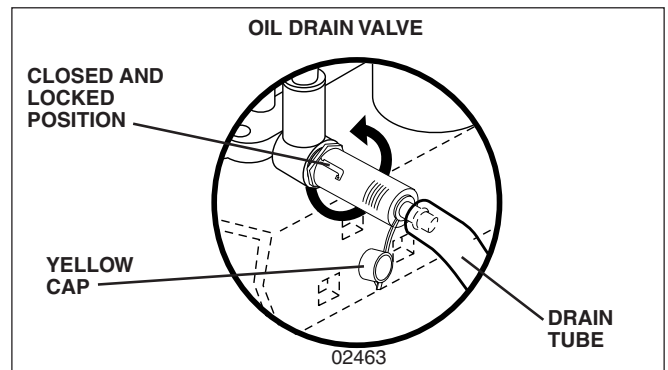

FIG. 16

# MAINTENANCE

- Unlock drain valve by pushing inward and turning counterclockwise.
- To open, pull out on the drain valve.
- After oil has drained completely, close and lock the drain valve by pushing inward and turning clockwise until the pin is in the locked position as shown.
- Remove the drain tube and replace the cap onto the bottom fitting of the drain valve.
- Refill engine with oil through oil fill dipstick tube. Pour slowly. Do not overfill. For approximate capacity see "PRODUCT SPECIFICATIONS" section of this manual.
- Use gauge on oil fill cap/dipstick for checking level. Be sure dipstick cap is tightened securely for accurate reading. Keep oil at "FULL" line on dipstick.

## CLEAN AIR SCREEN

Air screen must be kept free of dirt and chaff to prevent engine damage from overheating. Clean with a wire brush or compressed air to remove dirt and stubborn dried gum fibers.

## CLEAN AIR INTAKE/COOLING AREAS

To insure proper cooling, make sure the grass screen, cooling fins, and other external surfaces of the engine are kept clean at all times.

Every 100 hours of operation (more often under extremely dusty, dirty conditions), remove the blower housing and other cooling shrouds. Clean the cooling fins and external surfaces as necessary. Make sure the cooling shrouds are reinstalled.

**NOTE:** Operating the engine with a blocked grass screen, dirty or plugged cooling fins, and/or cooling shrouds removed will cause engine damage due to overheating.

## AIR FILTER (See Fig. 17)

Your engine will not run properly using a dirty air filter. Replace pre-cleaner after every 25 hours of operation or every season. Service paper cartridge every 100 hours of operation or every season, whichever occurs first.

Service air cleaner more often under dusty conditions.

- Pull up on air filter cover handle and rotate towards engine.
- Remove cover.
- Carefully remove air filter cartridge and pre-cleaner from base.
- Clean base carefully to prevent debris from falling into carburetor.

**NOTE:** If very dirty or damaged, replace cartridge.

- Place new pre-cleaner and cartridge firmly in base.
- Align tabs on cover with slots in blower housing and replace cover.
- Hook handle on cover and push down on handle to close.

**IMPORTANT:** Petroleum solvents, such as kerosene, are not to be used to clean the cartridge. They may cause deterioration of the cartridge. Do not oil cartridge. Do not use pressurized air to clean cartridge.

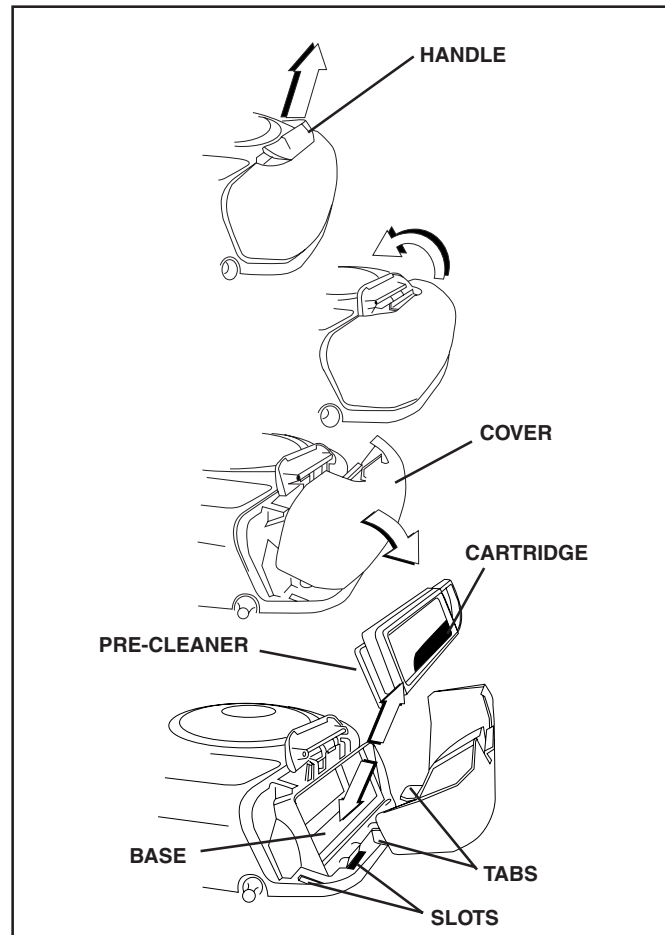

FIG. 17

## ENGINE OIL FILTER

Replace the engine oil filter every season or every other oil change if the tractor is used more than 100 hours in one year.

## MUFFLER

Inspect and replace corroded muffler and spark arrester (if equipped) as it could create a fire hazard and/or damage.

## SPARK PLUGS

Replace spark plugs at the beginning of each mowing season or after every 100 hours of operation, whichever occurs first. Spark plug type and gap setting are shown in "PRODUCT SPECIFICATIONS" section of this manual.

---

# MAINTENANCE

---

## IN-LINE FUEL FILTER (See Fig. 18)

The fuel filter should be replaced once each season. If fuel filter becomes clogged, obstructing fuel flow to carburetor, replacement is required.

- With engine cool, remove filter and plug fuel line sections.
- Place new fuel filter in position in fuel line with arrow pointing towards carburetor.
- Be sure there are no fuel line leaks and clamps are properly positioned.
- Immediately wipe up any spilled gasoline.

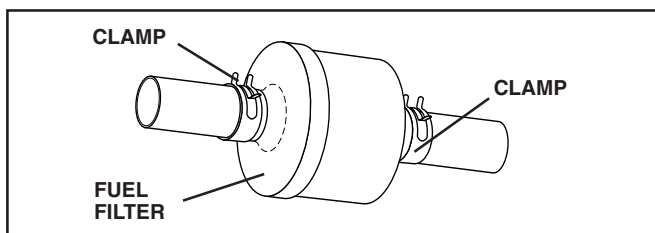

FIG. 18

## CLEANING

- Clean engine, battery, seat, finish, etc. of all foreign matter.
- Keep finished surfaces and wheels free of all gasoline, oil, etc.
- Protect painted surfaces with automotive type wax.

We do not recommend using a garden hose or pressure washer to clean your tractor unless the engine and transmission are covered to keep water out. Water in engine or transmission will shorten the useful life of your tractor. Use compressed air or a leaf blower to remove grass, leaves and trash from tractor and mower.

# SERVICE AND ADJUSTMENTS



**WARNING: TO AVOID SERIOUS INJURY, BEFORE PERFORMING ANY SERVICE OR ADJUSTMENTS:**

- Depress clutch/brake pedal fully and set parking brake.
- Place motion control lever in neutral (N) position.
- Place attachment clutch in “DISENGAGED” position.
- Turn ignition key to “STOP” and remove key.
- Make sure the blades and all moving parts have completely stopped.
- Disconnect spark plug wire from spark plug and place wire where it cannot come in contact with plug.

## TRACTOR

### TO REMOVE MOWER (See Fig. 19)

Mower will be easier to remove from the right side of tractor.

- Place attachment clutch in “DISENGAGED” position.
- Move attachment lift lever forward to lower mower to its lowest position.
- Roll belt off engine pulley.
- Remove small retainer spring, and remove clutch spring off pulley bolt.
- Remove large retainer spring, slide collar off and push housing guide out of bracket.
- Disconnect anti-swaybar from chassis bracket by removing retainer spring.
- Disconnect suspension arms from rear deck brackets by removing retainer springs.
- Disconnect front links from deck by removing retainer springs.

- Raise lift lever to raise suspension arms. Slide mower out from under tractor.

**IMPORTANT: IF AN ATTACHMENT OTHER THAN THE MOWER DECK IS TO BE MOUNTED ON THE TRACTOR, REMOVE THE FRONT LINKS AND HOOK THE CLUTCH SPRING INTO SQUARE HOLE IN FRAME.**

### TO INSTALL MOWER (See Fig. 19)

- Raise attachment lift lever to its highest position.
- Slide mower under tractor with deflector shield to right side of tractor.
- Lower lift lever to its lowest position.
- Connect front links to mower deck and secure with retainer springs..
- Connect suspension arms to rear deck brackets and secure with retainer springs.
- Connect anti-swaybar to chassis bracket and secure with retainer spring.
- Push clutch cable housing guide into bracket, slide collar onto guide and secure with large retainer spring.

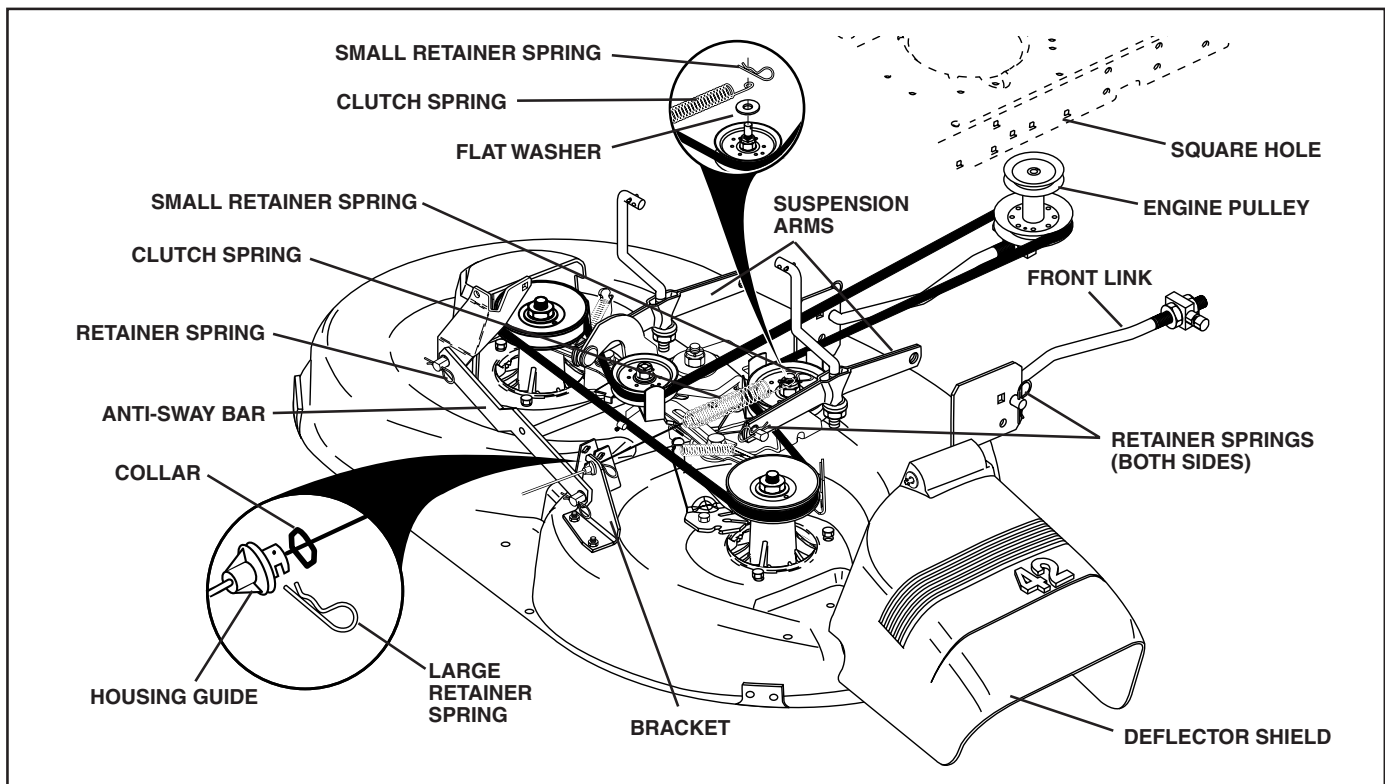

FIG. 19

# SERVICE AND ADJUSTMENTS

- Place flat washer and clutch spring on idler pulley bolt and secure with small retainer spring.
- Install belt onto engine pulley.

## TO LEVEL MOWER HOUSING

Adjust the mower while tractor is parked on level ground or driveway. Make sure tires are properly inflated (See "PRODUCT SPECIFICATIONS" section of this manual). If tires are over or underinflated, you will not properly adjust your mower.

SIDE-TO-SIDE ADJUSTMENT (See Figs. 20 and 21)

- Raise mower to its highest position.
- At the midpoint of both sides of mower, measure height from bottom edge of mower to ground. Distance "A" on both sides of mower should be the same or within 1/4" of each other.
- If adjustment is necessary, make adjustment on one side of mower only.
- To raise one side of mower, tighten lift link adjustment nut on that side.
- To lower one side of mower, loosen lift link adjustment nut on that side.

**NOTE:** Each full turn of adjustment nut will change mower height about 1/8".

- Recheck measurements after adjusting.

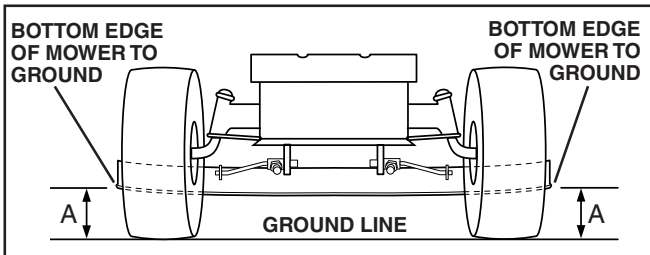

FIG. 20

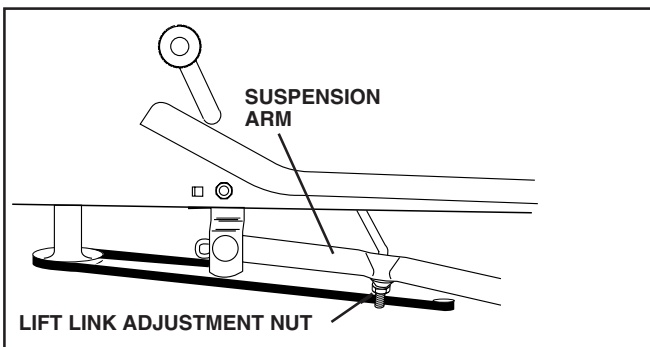

FIG. 21

FRONT-TO-BACK ADJUSTMENT (See Figs. 22 and 23)

**IMPORTANT:** DECK MUST BE LEVEL SIDE-TO-SIDE. IF THE FOLLOWING FRONT-TO-BACK ADJUSTMENT IS NECESSARY, BE SURE TO ADJUST BOTH FRONT LINKS EQUALLY SO MOWER WILL STAY LEVEL SIDE-TO-SIDE.

To obtain the best cutting results, the mower housing should be adjusted so that the front is approximately 1/8" to 1/2" lower than the rear when the mower is in its highest position.

Check adjustment on right side of tractor. Measure distance "D" directly in front and behind the mandrel at bottom edge of mower housing as shown.

- Before making any necessary adjustments, check that both front links are equal in length.
- If links are not equal in length, adjust one link to same length as other link.
- To lower front of mower loosen nut "E" on both front links an equal number of turns.
- When distance "D" is 1/8" to 1/2" lower at front than rear, tighten nuts "F" against trunnion on both front links.
- To raise front of mower, loosen nut "F" from trunnion on both front links. Tighten nut "E" on both front links an equal number of turns. The two front links must remain equal in length.
- When distance "D" is 1/8" to 1/2" lower at front than rear, tighten nut "F" against trunnion on both front links.
- Recheck side-to-side adjustment.

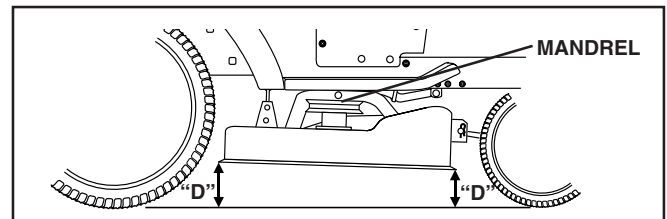

FIG. 22

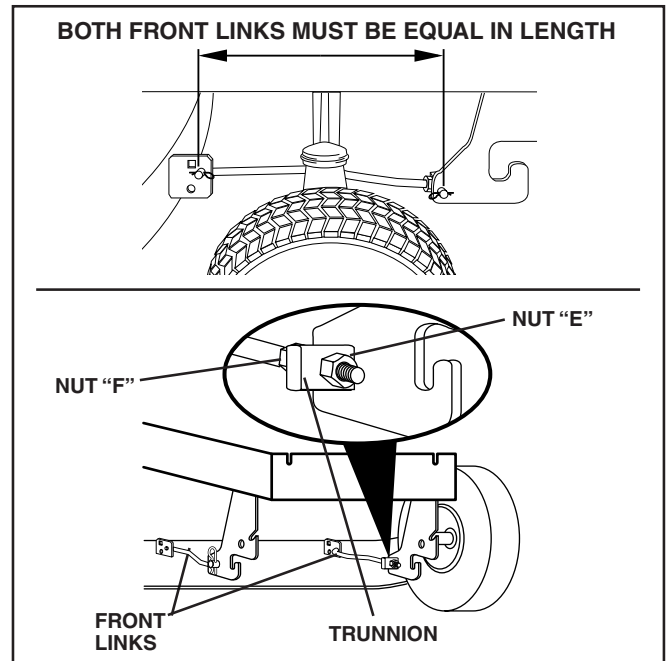

FIG. 23

# SERVICE AND ADJUSTMENTS

## TO REPLACE MOWER BLADE DRIVE BELT (See Fig. 24)

The mower blade drive belt may be replaced without tools. Park the tractor on level surface. Engage parking brake.

### BELT REMOVAL -

- Remove mower from tractor (See "TO REMOVE MOWER" in this section of this manual).
- Work belt off both mandrel pulleys and idler pulleys.
- Pull belt away from mower.

### BELT INSTALLATION -

- Install new belt in reverse order of removal.
- Make sure belt is in all pulley grooves and inside all belt guides.
- Install mower in reverse order of removal instructions.

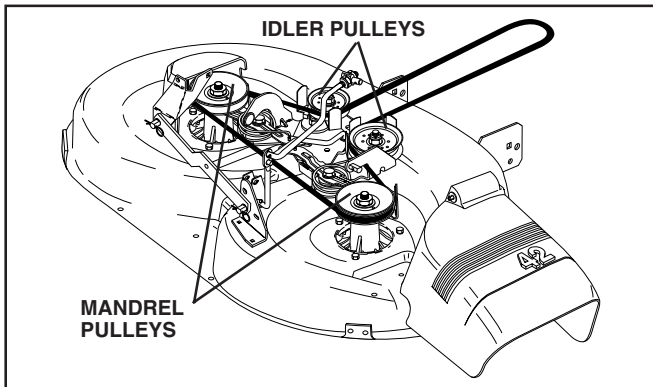

FIG. 24

## TO CHECK AND ADJUST BRAKE (See Fig. 25)

Your tractor is equipped with an adjustable brake system which is mounted on the right side of the transaxle.

If tractor requires more than five (5) feet to stop at highest speed in highest gear on a level, dry concrete or paved surface, then brake must be checked and adjusted.

### TO CHECK BRAKE

- Park tractor on a level, dry concrete or paved surface, depress clutch/brake pedal all the way down and engage parking brake.
- Disengage transmission by placing freewheel control in "transmission disengaged" position. Pull freewheel control out and into the slot and release so it is held in the disengaged position.

The rear wheels must lock and skid when you try to manually push the tractor forward. If the rear wheels rotate, the brake needs to be adjusted or the pads need to be replaced.

### TO ADJUST BRAKE

- Depress clutch/brake pedal all the way down and engage parking brake.
- Measure distance between brake operating arm and nut "A" on brake rod.
- If distance is other than 1-9/16", loosen jam nut and turn nut "A" until distance becomes 1-9/16". Retighten jam nut against nut "A".

- Engage transmission by placing freewheel control in "transmission engaged" position.
- Road test tractor for proper stopping distance as stated above. Readjust if necessary. If stopping distance is still greater than five (5) feet in highest gear, further maintenance is necessary. Replace brake pads or contact a qualified service center.

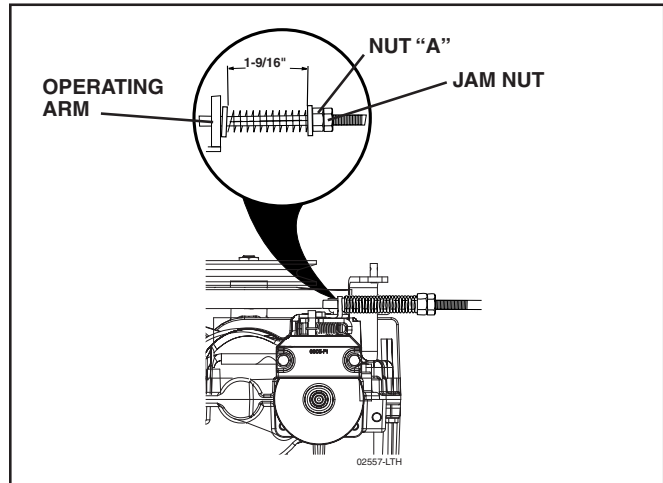

FIG. 25

## TO REPLACE MOTION DRIVE BELT (See Fig. 26)

Park the tractor on level surface. Engage parking brake. For assistance, there is a belt installation guide decal on bottom side of left footrest.

### BELT REMOVAL -

- Remove mower (See "TO REMOVE MOWER" in this section of manual).

**NOTE:** Observe entire motion drive belt and position of all belt guides and keepers.

- Remove belt from stationary idler and clutching idler.
- Remove belt downward from around engine pulley.
- Pull belt slack toward rear of tractor. Carefully remove belt upwards from transmission input pulley.
- Remove belt from center span keeper and pull belt away from tractor.

### BELT INSTALLATION -

- Carefully work new belt down and onto the input pulley.
- Slide belt into the center span keeper.
- Pull belt toward front of tractor and roll around the top groove of engine pulley.
- Install belt through stationary idler and clutching idler.
- Make sure belt is in all pulley grooves and inside all belt guides and keepers.
- Install mower (See "TO INSTALL MOWER" in this section of manual).

# SERVICE AND ADJUSTMENTS

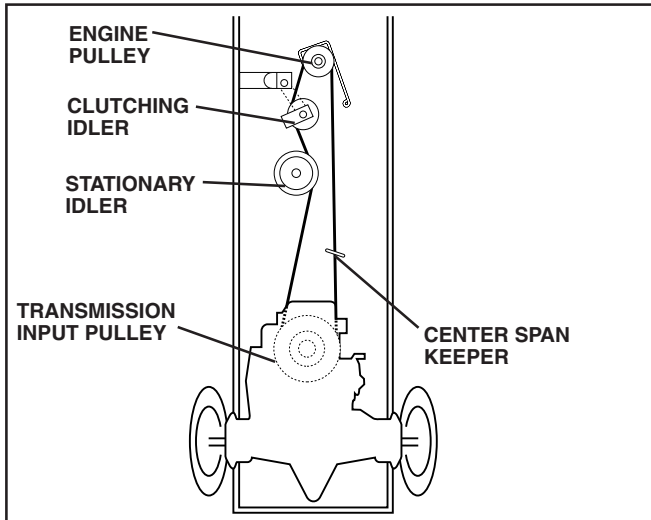

FIG. 26

## TRANSAXLE MOTION CONTROL LEVER NEUTRAL ADJUSTMENT(See Fig. 27)

The motion control lever has been preset at the factory and adjustment should not be necessary.

- Loosen adjustment bolt in front of the right rear wheel, and lightly tighten.
- Start engine and move motion control lever until tractor does not move forward or backward.
- Hold motion control lever in that position and turn engine off.
- While holding motion control lever in place, loosen the adjustment bolt.
- Move motion control lever to the neutral (N) (lock gate) position.
- Tighten adjustment bolt securely.

**NOTE:** If additional clearance is needed to get to adjustment bolt, move mower deck height to the lowest position.

After above adjustment is made, if the tractor still creeps forward or backward while motion control lever is in neutral position, follow these steps:

- Loosen the adjustment bolt.
- Move the motion control lever 1/4 to 1/2 inch in the direction it is trying to creep.
- Tighten adjustment bolt securely.
- Start engine and test.
- If tractor still creeps, repeat above steps until satisfied.

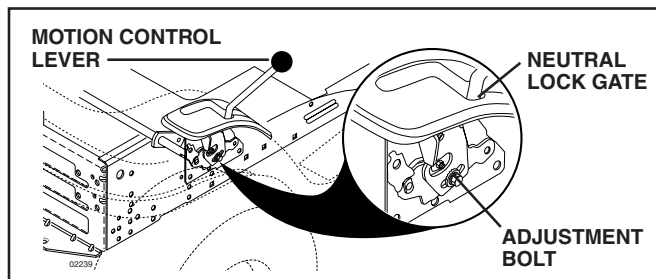

FIG. 27

## TRANSMISSION REMOVAL/REPLACEMENT

Should your transmission require removal for service or replacement, it should be purged after reinstallation and before operating the tractor. See "PURGE TRANSMISSION" in the Operation section of this manual.

## TO ADJUST STEERING WHEEL ALIGNMENT

If steering wheel crossbars are not horizontal (left to right) when wheels are positioned straight forward, remove steering wheel and reassemble per instructions in the Assembly section of this manual.

## FRONT WHEEL TOE-IN/CAMBER

The front wheel toe-in and camber are not adjustable on your tractor. If damage has occurred to affect the front wheel toe-in or camber, contact your nearest authorized service center/department.

## TO REMOVE WHEEL FOR REPAIRS (See Fig. 28)

- Block up axle securely.
- Remove axle cover, retaining ring and washers to allow wheel removal (rear wheel contains a square key - Do not lose).
- Repair tire and reassemble.
- On rear wheels only: align grooves in rear wheel hub and axle. Insert square key.
- Replace washers and snap retaining ring securely in axle groove.
- Replace axle cover.

**NOTE:** To seal tire punctures and prevent flat tires due to slow leaks, tire sealant may be purchased from your local parts dealer. Tire sealant also prevents tire dry rot and corrosion.

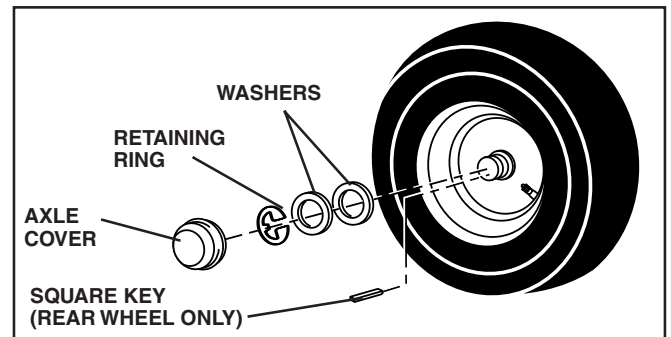

FIG. 28

# SERVICE AND ADJUSTMENTS

## TO START ENGINE WITH A WEAK BATTERY (See Fig. 29)



**WARNING:** Lead-acid batteries generate explosive gases. Keep sparks, flame and smoking materials away from batteries. Always wear eye protection when around batteries.

If your battery is too weak to start the engine, it should be recharged. (See "BATTERY" in the Maintenance section of this manual).

If "jumper cables" are used for emergency starting, follow this procedure:

**IMPORTANT:** YOUR TRACTOR IS EQUIPPED WITH A 12 VOLT SYSTEM. THE OTHER VEHICLE MUST ALSO BE A 12 VOLT SYSTEM. DO NOT USE YOUR TRACTOR BATTERY TO START OTHER VEHICLES.

### TO ATTACH JUMPER CABLES -

- Connect one end of the RED cable to the POSITIVE (+) terminal of each battery(A-B), taking care not to short against tractor chassis.
- Connect one end of the BLACK cable to the NEGATIVE (-) terminal (C) of fully charged battery.
- Connect the other end of the BLACK cable (D) to good chassis ground, away from fuel tank and battery.

### TO REMOVE CABLES, REVERSE ORDER -

- BLACK cable first from chassis and then from the fully charged battery.
- RED cable last from both batteries.

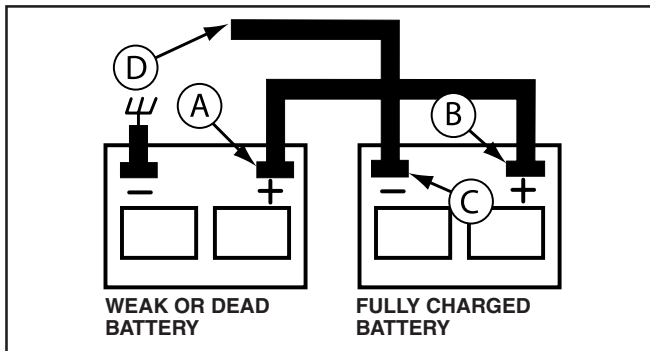

FIG. 29

## TO REPLACE HEADLIGHT BULB

- Raise hood.
- Pull bulb holder out of the hole in the backside of the grill.
- Replace bulb in holder and push bulb holder securely back into the hole in the backside of the grill.
- Close hood.

## INTERLOCKS AND RELAYS

Loose or damaged wiring may cause your tractor to run poorly, stop running, or prevent it from starting.

- Check wiring. See electrical wiring diagram in the Repair Parts section.

## TO REPLACE FUSE

Replace with 20 amp automotive-type plug-in fuse. The fuse holder is located behind the dash.

## TO REMOVE HOOD AND GRILL ASSEMBLY (See Fig. 30)

- Raise hood.
- Unsnap headlight wire connector.
- Stand in front of tractor. Grasp hood at sides, tilt toward engine and lift off of tractor.
- To replace, reverse above procedure.

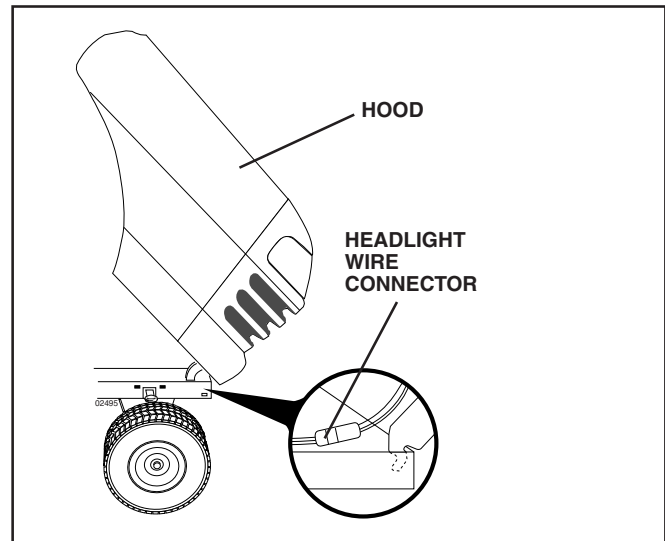

FIG. 30



# SERVICE AND ADJUSTMENTS

## ENGINE

Maintenance, repair, or replacement of the emission control devices and systems, which are being done at the customer's expense, may be performed by any non-road engine repair establishment or individual. Warranty repairs must be performed by an authorized engine manufacturer's service outlet.

### TO ADJUST THROTTLE CONTROL CABLE (See Fig. 31)

The throttle control has been preset at the factory and adjustment should not be necessary. Check adjustment as described below before loosening cable. If adjustment is necessary, proceed as follows:

- With engine not running, move throttle control lever from slow to choke position. Slowly move lever from choke to fast position.
- Check that holes "A" in governor control lever and hole in governor control plate line-up. If holes "A" are not aligned, loosen clamp screw and move throttle cable until holes are aligned. Tighten clamp screw securely.

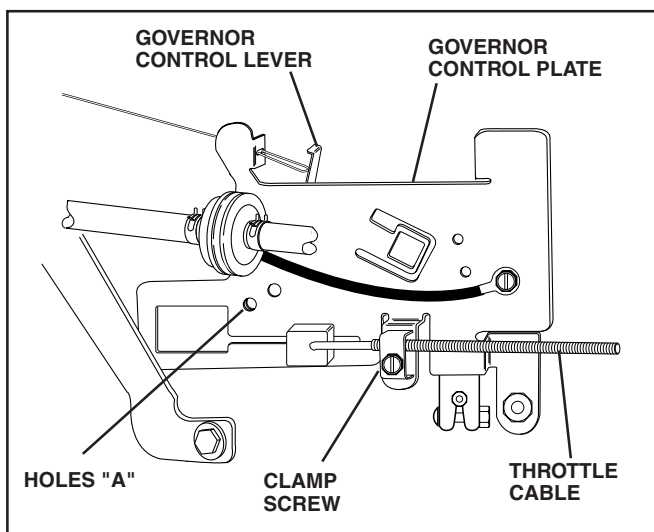

FIG. 31

### TO ADJUST CARBURETOR (See Fig. 32)

**NOTE:** The carburetor on this engine is low emission. It is equipped with an idle fuel adjusting needle with a limiter cap, which allows some adjustment within the limits allowed by the cap. Do not attempt to remove the limiter cap. The limiter cap cannot be removed without breaking the adjusting needle.

The carburetor has been preset at the factory and adjustment should not be necessary. However, minor adjustment may be required to compensate for differences in fuel, temperature, altitude or load. If the carburetor does need adjustment, proceed as follows:

In general, turning idle mixture valve **in** (clockwise) decreases the supply of fuel to the engine giving a leaner fuel/air mixture. Turning the idle mixture valve **out** (counterclockwise) increases the supply of fuel to the engine giving a richer fuel/air mixture.

**IMPORTANT:** DAMAGE TO THE NEEDLE VALVE AND THE SEAT IN CARBURETOR MAY RESULT IF SCREW IS TURNED IN TOO TIGHT.

#### PRELIMINARY SETTING -

- Air cleaner assembly must be assembled to the carburetor when making carburetor adjustments.
- Be sure the throttle control cable is adjusted properly (see above).

#### FINAL SETTING -

- Start engine and allow to warm for five minutes. Make final adjustments with engine running and shift/motion control lever in neutral (**N**) position.
- Move throttle control lever to slow position. With finger, rotate and hold throttle lever against idle speed screw. Turn idle speed screw to attain 1750 RPM.
- While still holding throttle lever against idle speed screw, turn idle mixture valve full travel clockwise then counterclockwise until engine runs rough. Turn valve to a point midway between those two positions. Release throttle lever.

#### ACCELERATION TEST -

- Move throttle control lever from slow to fast position. If engine hesitates or dies, turn idle mixture valve **out** (counterclockwise) 1/8 turn. Repeat test and continue to adjust, if necessary, until engine accelerates smoothly.

High speed stop is factory adjusted. Do not adjust - damage may result.

**IMPORTANT:** NEVER TAMPER WITH THE ENGINE GOVERNOR, WHICH IS FACTORY SET FOR PROPER ENGINE SPEED. OVERSPEEDING THE ENGINE ABOVE THE FACTORY HIGH SPEED SETTING CAN BE DANGEROUS. IF YOU THINK THE ENGINE-GOVERNED HIGH SPEED NEEDS ADJUSTING, CONTACT YOUR NEAREST AUTHORIZED SERVICE CENTER/DEPARTMENT, WHICH HAS PROPER EQUIPMENT AND EXPERIENCE TO MAKE ANY NECESSARY ADJUSTMENTS.

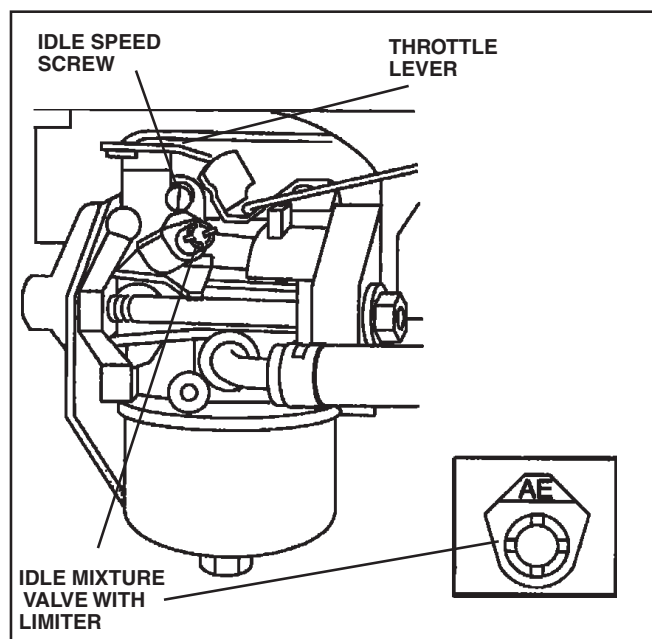

FIG. 32

---

# STORAGE

---

Immediately prepare your tractor for storage at the end of the season or if the tractor will not be used for 30 days or more.



**WARNING: Never store the tractor with gasoline in the tank inside a building where fumes may reach an open flame or spark. Allow the engine to cool before storing in any enclosure.**

## TRACTOR

Remove mower from tractor for winter storage. When mower is to be stored for a period of time, clean it thoroughly, remove all dirt, grease, leaves, etc. Store in a clean, dry area.

- Clean entire tractor (See “CLEANING” in the Maintenance section of this manual).
- Inspect and replace belts, if necessary (See belt replacement instructions in the Service and Adjustments section of this manual).
- Lubricate as shown in the Maintenance section of this manual.
- Be sure that all nuts, bolts and screws are securely fastened. Inspect moving parts for damage, breakage and wear. Replace if necessary.
- Touch up all rusted or chipped paint surfaces; sand lightly before painting.

## BATTERY

- Fully charge the battery for storage.
- After a period of time in storage, battery may require recharging.
- To help prevent corrosion and power leakage during long periods of storage, battery cables should be disconnected and battery cleaned thoroughly (see “TO CLEAN BATTERY AND TERMINALS” in the Maintenance section of this manual).
- After cleaning, leave cables disconnected and place cables where they cannot come in contact with battery terminals.
- If battery is removed from tractor for storage, do not store battery directly on concrete or damp surfaces.

## ENGINE

### FUEL SYSTEM

**IMPORTANT:** IT IS IMPORTANT TO PREVENT GUM DEPOSITS FROM FORMING IN ESSENTIAL FUEL SYSTEM PARTS SUCH AS CARBURETOR, FUEL FILTER, FUEL HOSE, OR TANK DURING STORAGE. ALSO, EXPERIENCE INDICATES THAT ALCOHOL BLENDED FUELS (CALLED GASOHOL OR USING ETHANOL OR METHANOL) CAN ATTRACT MOISTURE WHICH LEADS TO SEPARATION AND FORMATION OF ACIDS DURING STORAGE. ACIDIC GAS CAN DAMAGE THE FUEL SYSTEM OF AN ENGINE WHILE IN STORAGE.

- Drain the fuel tank.
- Start the engine and let it run until the fuel lines and carburetor are empty.
- Never use engine or carburetor cleaner products in the fuel tank or permanent damage may occur.
- Use fresh fuel next season.

**NOTE:** Fuel stabilizer is an acceptable alternative in minimizing the formation of fuel gum deposits during storage. Add stabilizer to gasoline in fuel tank or storage container. Always follow the mix ratio found on stabilizer container. Run engine at least 10 minutes after adding stabilizer to allow the stabilizer to reach the carburetor. Do not drain the gas tank and carburetor if using fuel stabilizer.

### ENGINE OIL

Drain oil (with engine warm) and replace with clean engine oil. (See “ENGINE” in the Maintenance section of this manual).

### CYLINDER(S)

- Remove spark plug(s).
- Pour one ounce of oil through spark plug hole(s) into cylinder(s).
- Turn ignition key to “START” position for a few seconds to distribute oil.
- Replace with new spark plug(s).

### OTHER

- Do not store gasoline from one season to another.
- Replace your gasoline can if your can starts to rust. Rust and/or dirt in your gasoline will cause problems.
- If possible, store your tractor indoors and cover it to give protection from dust and dirt.
- Cover your tractor with a suitable protective cover that does not retain moisture. Do not use plastic. Plastic cannot breathe which allows condensation to form and will cause your tractor to rust.

**IMPORTANT:** NEVER COVER TRACTOR WHILE ENGINE AND EXHAUST ARE STILL WARM.

# TROUBLESHOOTING POINTS

PROBLEM	CAUSE	CORRECTION
<b>Will not start</b>	<ol style="list-style-type: none"> <li>1. Out of fuel.</li> <li>2. Engine not "CHOKED" properly.</li> <li>3. Engine flooded.</li> <li>4. Bad spark plug.</li> <li>5. Dirty air filter.</li> <li>6. Dirty fuel filter.</li> <li>7. Water in fuel.</li> <li>8. Loose or damaged wiring.</li> <li>9. Carburetor out of adjustment.</li> <li>10. Engine valves out of adjustment.</li> </ol>	<ol style="list-style-type: none"> <li>1. Fill fuel tank.</li> <li>2. See "TO START ENGINE" in Operation section.</li> <li>3. Wait several minutes before attempting to start.</li> <li>4. Replace spark plug.</li> <li>5. Clean/replace air filter.</li> <li>6. Replace fuel filter.</li> <li>7. Drain fuel tank and carburetor, refill tank with fresh gasoline and replace fuel filter.</li> <li>8. Check all wiring.</li> <li>9. See "To Adjust Carburetor" in Service Adjustments section.</li> <li>10. Contact an authorized service center/department.</li> </ol>
<b>Hard to start</b>	<ol style="list-style-type: none"> <li>1. Dirty air filter.</li> <li>2. Bad spark plug.</li> <li>3. Weak or dead battery.</li> <li>4. Dirty fuel filter.</li> <li>5. Stale or dirty fuel.</li> <li>6. Loose or damaged wiring.</li> <li>7. Carburetor out of adjustment.</li> <li>8. Engine valves out of adjustment.</li> </ol>	<ol style="list-style-type: none"> <li>1. Clean/replace air filter.</li> <li>2. Replace spark plug.</li> <li>3. Recharge or replace battery.</li> <li>4. Replace fuel filter.</li> <li>5. Drain fuel tank and refill with fresh gasoline.</li> <li>6. Check all wiring.</li> <li>7. See "To Adjust Carburetor" in Service Adjustments section.</li> <li>8. Contact an authorized service center/department.</li> </ol>
<b>Engine will not turn over</b>	<ol style="list-style-type: none"> <li>1. Clutch/brake pedal not depressed.</li> <li>2. Attachment clutch is engaged.</li> <li>3. Weak or dead battery.</li> <li>4. Blown fuse.</li> <li>5. Corroded battery terminals.</li> <li>6. Loose or damaged wiring.</li> <li>7. Faulty ignition switch.</li> <li>8. Faulty solenoid or starter.</li> <li>9. Faulty operator presence switch(es).</li> </ol>	<ol style="list-style-type: none"> <li>1. Depress clutch/brake pedal.</li> <li>2. Disengage attachment clutch.</li> <li>3. Recharge or replace battery.</li> <li>4. Replace fuse.</li> <li>5. Clean battery terminals.</li> <li>6. Check all wiring.</li> <li>7. Check/replace ignition switch.</li> <li>8. Check/replace solenoid or starter.</li> <li>9. Contact an authorized service center/department.</li> </ol>
<b>Engine clicks but will not start</b>	<ol style="list-style-type: none"> <li>1. Weak or dead battery.</li> <li>2. Corroded battery terminals.</li> <li>3. Loose or damaged wiring.</li> <li>4. Faulty solenoid or starter.</li> </ol>	<ol style="list-style-type: none"> <li>1. Recharge or replace battery.</li> <li>2. Clean battery terminals.</li> <li>3. Check all wiring.</li> <li>4. Check/replace solenoid or starter.</li> </ol>
<b>Loss of power</b>	<ol style="list-style-type: none"> <li>1. Cutting too much grass/too fast.</li> <li>2. Throttle in "CHOKE" position.</li> <li>3. Build-up of grass, leaves and trash under mower.</li> <li>4. Dirty air filter.</li> <li>5. Low oil level/dirty oil.</li> <li>6. Faulty spark plug.</li> <li>7. Dirty fuel filter.</li> <li>8. Stale or dirty fuel.</li> <li>9. Water in fuel.</li> <li>10. Spark plug wire loose.</li> <li>11. Dirty engine air screen/fins.</li> <li>12. Dirty/clogged muffler.</li> <li>13. Loose or damaged wiring.</li> <li>14. Carburetor out of adjustment.</li> <li>15. Engine valves out of adjustment.</li> </ol>	<ol style="list-style-type: none"> <li>1. Set in "Higher Cut" position/reduce speed.</li> <li>2. Adjust throttle control.</li> <li>3. Clean underside of mower housing.</li> <li>4. Clean/replace air filter.</li> <li>5. Check oil level/change oil.</li> <li>6. Clean and regap or change spark plug.</li> <li>7. Replace fuel filter.</li> <li>8. Drain fuel tank and refill with fresh gasoline.</li> <li>9. Drain fuel tank and carburetor, refill tank with fresh gasoline and replace fuel filter.</li> <li>10. Connect and tighten spark plug wire.</li> <li>11. Clean engine air screen/fins.</li> <li>12. Clean/replace muffler.</li> <li>13. Check all wiring.</li> <li>14. See "To Adjust Carburetor" in Service Adjustments section.</li> <li>15. Contact an authorized service center/department.</li> </ol>
<b>Excessive vibration</b>	<ol style="list-style-type: none"> <li>1. Worn, bent or loose blade.</li> <li>2. Bent blade mandrel.</li> <li>3. Loose/damaged part(s).</li> </ol>	<ol style="list-style-type: none"> <li>1. Replace blade. Tighten blade bolt.</li> <li>2. Replace blade mandrel.</li> <li>3. Tighten loose part(s). Replace damaged parts.</li> </ol>

# TROUBLESHOOTING POINTS

PROBLEM	CAUSE	CORRECTION
<b>Engine continues to run when operator leaves seat with attachment clutch engaged</b>	<ol style="list-style-type: none"> <li>1. Faulty operator-safety presence control system.</li> </ol>	<ol style="list-style-type: none"> <li>1. Check wiring, switches and connections. If not corrected, contact an authorized service center/ department.</li> </ol>
<b>Poor cut - uneven</b>	<ol style="list-style-type: none"> <li>1. Worn, bent or loose blade.</li> <li>2. Mower deck not level.</li> <li>3. Buildup of grass, leaves, and trash under mower.</li> <li>4. Bent blade mandrel.</li> <li>5. Clogged mower deck vent holes from buildup of grass, leaves, and trash around mandrels.</li> </ol>	<ol style="list-style-type: none"> <li>1. Replace blade. Tighten blade bolt.</li> <li>2. Level mower deck.</li> <li>3. Clean underside of mower housing.</li> <li>4. Replace blade mandrel.</li> <li>5. Clean around mandrels to open vent holes.</li> </ol>
<b>Mower blades will not rotate</b>	<ol style="list-style-type: none"> <li>1. Obstruction in clutch mechanism.</li> <li>2. Worn/damaged mower drive belt.</li> <li>3. Frozen idler pulley.</li> <li>4. Frozen blade mandrel.</li> </ol>	<ol style="list-style-type: none"> <li>1. Remove obstruction.</li> <li>2. Replace mower drive belt.</li> <li>3. Replace idler pulley.</li> <li>4. Replace blade mandrel.</li> </ol>
<b>Poor grass discharge</b>	<ol style="list-style-type: none"> <li>1. Engine speed too slow.</li> <li>2. Travel speed too fast.</li> <li>3. Wet grass.</li> <li>4. Mower deck not level.</li> <li>5. Low/uneven tire air pressure.</li> <li>6. Worn, bent or loose blade.</li> <li>7. Buildup of grass, leaves and trash under mower.</li> <li>8. Mower drive belt worn.</li> <li>9. Blades improperly installed.</li> <li>10. Improper blades used.</li> <li>11. Clogged mower deck vent holes from buildup of grass, leaves, and trash around mandrels.</li> </ol>	<ol style="list-style-type: none"> <li>1. Place throttle control in "FAST" position.</li> <li>2. Shift to slower speed.</li> <li>3. Allow grass to dry before mowing.</li> <li>4. Level mower deck.</li> <li>5. Check tires for proper air pressure.</li> <li>6. Replace/sharpen blade. Tighten blade bolt.</li> <li>7. Clean underside of mower housing.</li> <li>8. Replace mower drive belt.</li> <li>9. Reinstall blades sharp edge down.</li> <li>10. Replace with blades listed in this manual.</li> <li>11. Clean around mandrels to open vent holes.</li> </ol>
<b>Headlight(s) not working (if so equipped)</b>	<ol style="list-style-type: none"> <li>1. Switch is "OFF".</li> <li>2. Bulb(s) or lamp(s) burned out.</li> <li>3. Faulty light switch.</li> <li>4. Loose or damaged wiring.</li> <li>5. Blown fuse.</li> </ol>	<ol style="list-style-type: none"> <li>1. Turn switch "ON".</li> <li>2. Replace bulb(s) or lamp(s).</li> <li>3. Check/replace light switch.</li> <li>4. Check wiring and connections.</li> <li>5. Replace fuse.</li> </ol>
<b>Battery will not charge</b>	<ol style="list-style-type: none"> <li>1. Bad battery cell(s).</li> <li>2. Poor cable connections.</li> <li>3. Faulty regulator (if so equipped).</li> <li>4. Faulty alternator.</li> </ol>	<ol style="list-style-type: none"> <li>1. Replace battery.</li> <li>2. Check/clean all connections.</li> <li>3. Replace regulator.</li> <li>4. Replace alternator.</li> </ol>
<b>Loss of drive</b>	<ol style="list-style-type: none"> <li>1. Freewheel control in "disengaged" position.</li> <li>2. Motion drive belt worn, damaged, or broken.</li> <li>3. Air trapped in transmission during shipment or servicing.</li> </ol>	<ol style="list-style-type: none"> <li>1. Place freewheel control in "engaged" position.</li> <li>2. Replace motion drive belt.</li> <li>3. Purge transmission.</li> </ol>
<b>Engine "backfires" when turning engine "OFF"</b>	<ol style="list-style-type: none"> <li>1. Engine throttle control not set at "SLOW" position for 30 seconds before stopping engine.</li> </ol>	<ol style="list-style-type: none"> <li>1. Move throttle control to "SLOW" position and allow to idle for 30 seconds before stopping engine.</li> </ol>

# TRACTOR - - MODEL NUMBER 944.604881

## SCHEMATIC

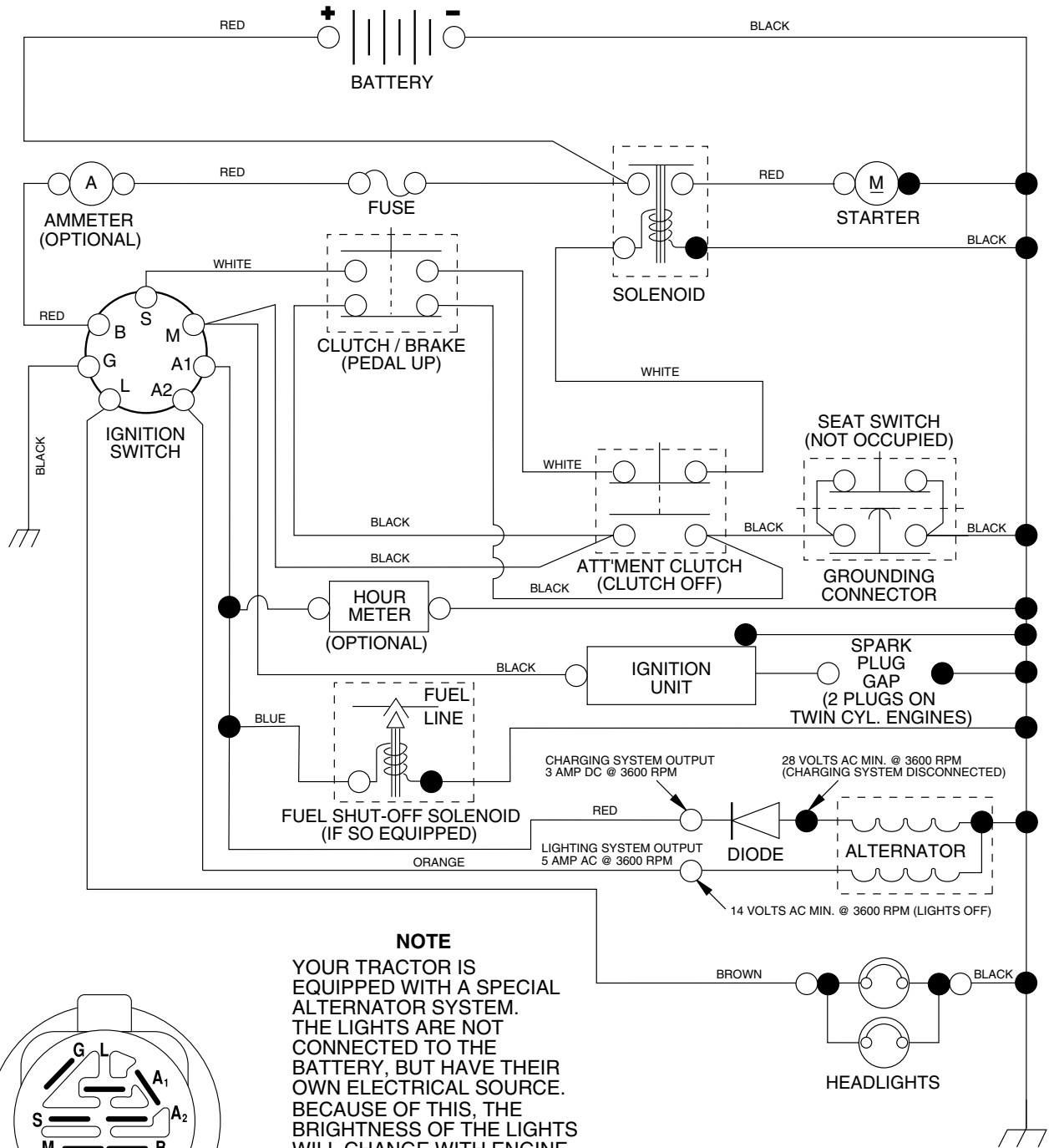

### NOTE

YOUR TRACTOR IS EQUIPPED WITH A SPECIAL ALTERNATOR SYSTEM. THE LIGHTS ARE NOT CONNECTED TO THE BATTERY, BUT HAVE THEIR OWN ELECTRICAL SOURCE. BECAUSE OF THIS, THE BRIGHTNESS OF THE LIGHTS WILL CHANGE WITH ENGINE SPEED. AT IDLE THE LIGHTS WILL DIM. AS THE ENGINE IS SPEEDED UP, THE LIGHTS WILL BECOME THEIR BRIGHTEST.

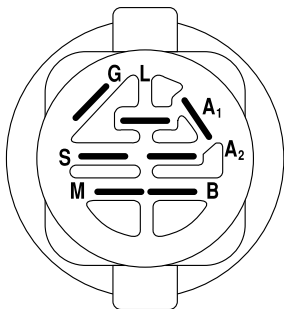

### IGNITION SWITCH

POSITION	CIRCUIT	"MAKE"
OFF	M+G+A1	NONE
RUN/LIGHT	B+A1	A2+L
RUN	B+A1	NONE
START	B + S + A1	NONE

### WIRING INSULATED CLIPS

**NOTE:** IF WIRING INSULATED CLIPS WERE REMOVED FOR SERVICING OF UNIT, THEY SHOULD BE REPLACED TO PROPERLY SECURE YOUR WIRING.

NON-REMOVABLE CONNECTIONS

REMOVABLE CONNECTIONS

# REPAIR PARTS

TRACTOR -- MODEL NUMBER 944.604881

## ELECTRICAL

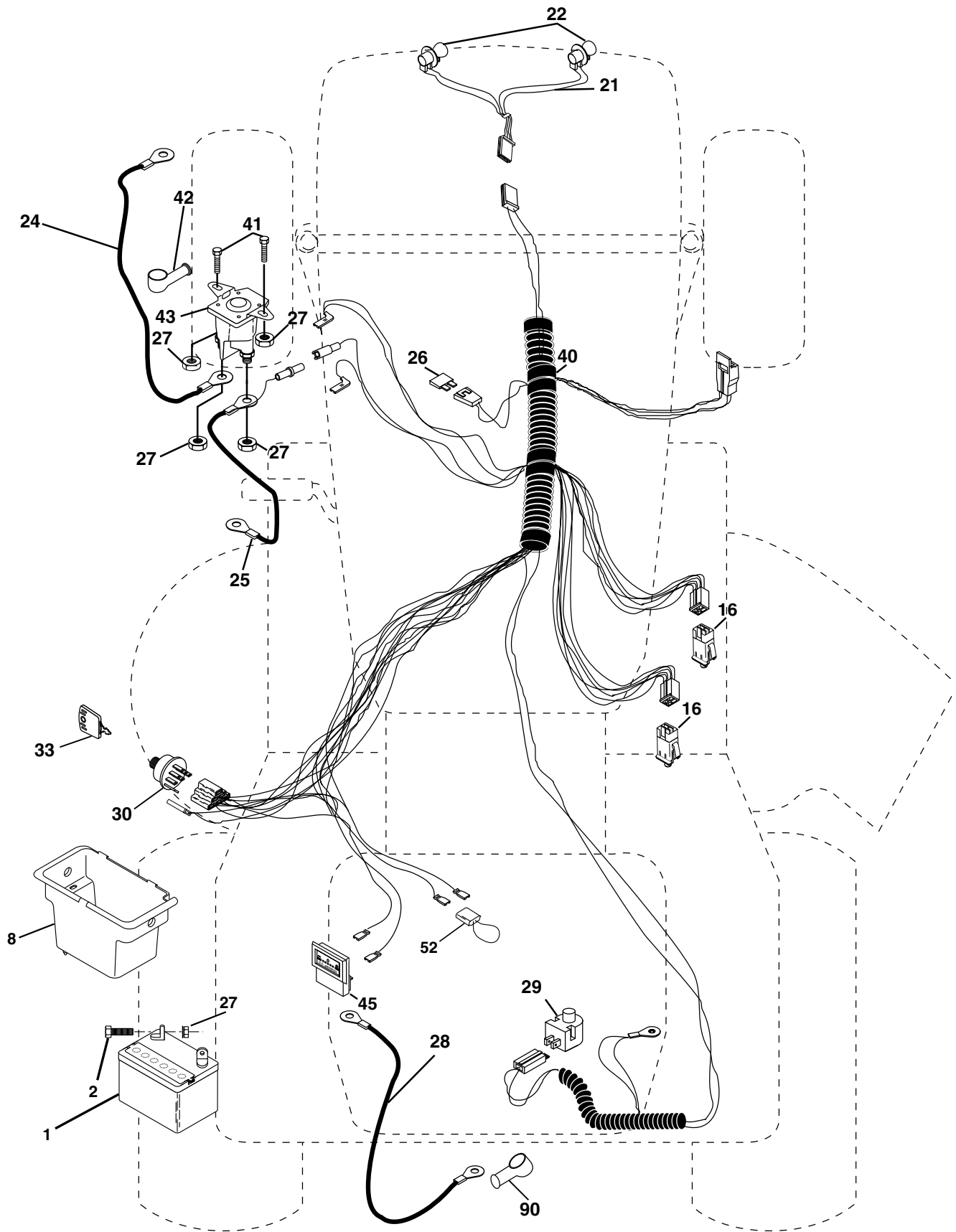

# REPAIR PARTS

## TRACTOR - - MODEL NUMBER 944.604881

### ELECTRICAL

KEY NO.	PART NO.	DESCRIPTION
1	163495	Battery
2	74760412	Bolt Hex Hd 1/4-20 Unc x 3/4
8	176689	Box Battery
16	176138	Switch Interlock Push-In
21	175688	Harness Asm Light W/4152J
22	4152J	Bulb Light #1156
24	4799J	Cable Battery 6 Ga 11"red
25	146147	Cable Battery
26	175158	Fuse
27	73510400	Nut Keps Hex 1/4-20 Unc
28	4207J	Cable Ground
29	121305X	Switch Plunger Nc Olive
30	175566	Switch Ign 3
33	140403	Key Ign
40	179720	Harness Ign
41	71110408	Bolt Blk Fin Hex 1/4-20 Unc x 1/2
42	131563	Cover Terminal Red
43	178861	Solenoid
45	121433X	Ammeter
52	141940	Protection Wire Loop (Hourmeter)
90	180449	Cover Terminal

**NOTE:** All component dimensions give in U.S. inches  
1 inch = 25.4 mm.

# REPAIR PARTS

## TRACTOR - - MODEL NUMBER 944.604881

### CHASSIS AND ENCLOSURES

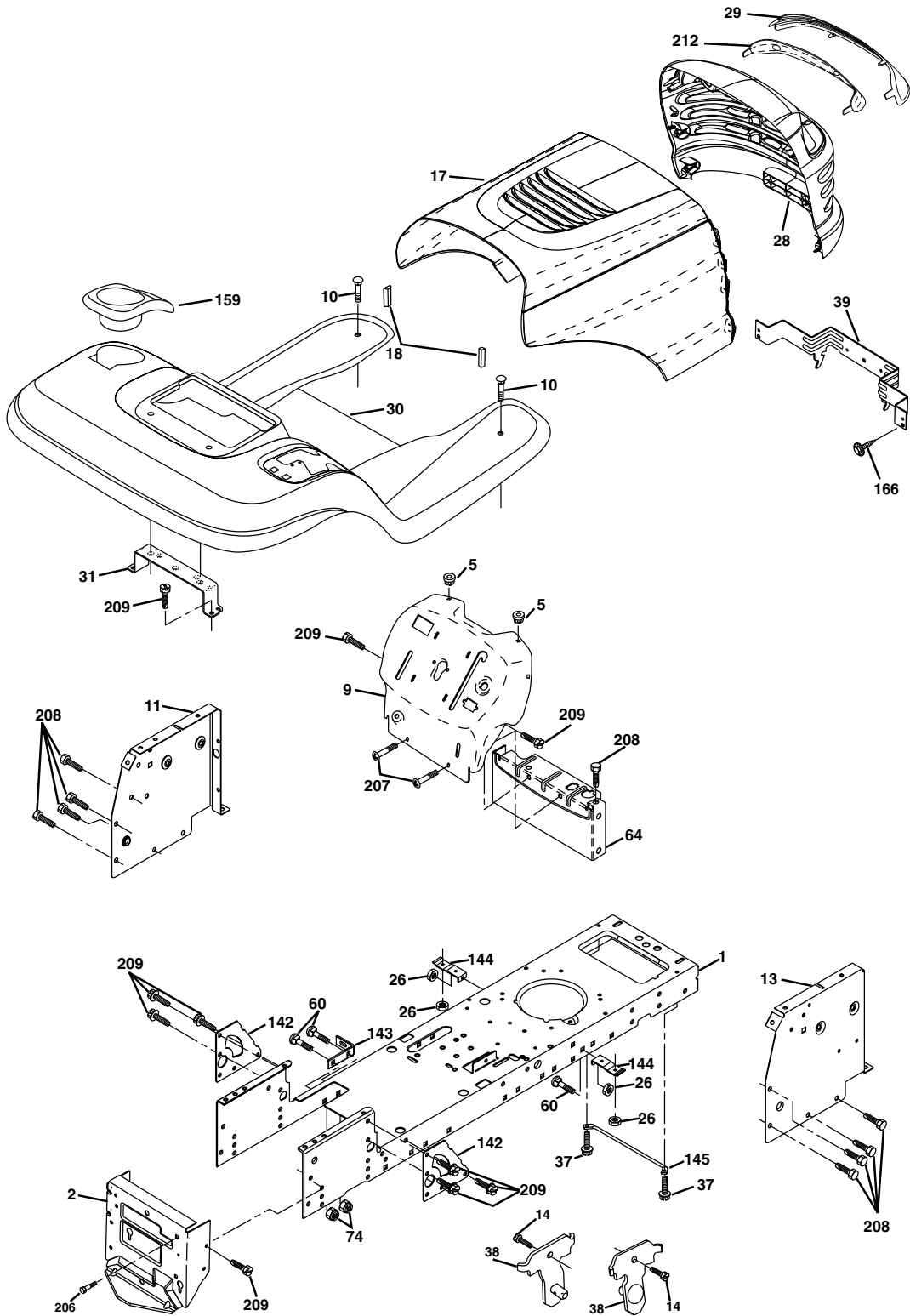

chassis-Laser -lt.stlt\_30



# REPAIR PARTS

## TRACTOR - - MODEL NUMBER 944.604881

### CHASSIS AND ENCLOSURES

KEY NO.	PART NO.	DESCRIPTION
1	174619	Chassis Stl Stamping
2	176554	Drawbar, Stretch
5	155272	Bumper Hood/Dash
9	168337X011	Dash P/L
10	STD533710	Bolt Carriage 3/8-16 x 1
11	174996	Panel Dash Lh
13	172105X010	Panel Dash Rh
14	17490608	Screw Thdrol 3/8-16 x 1/2
17	185682X558	Hood
18	184921	Bumper Hood
26	STD541437	Nut Lock Hex W/Ins 3/8-16 Unc
28	175049	Grille/Lens Asm
29	174332X599	Lens
30	<b>175692X558</b>	Fender Footrest STLT Pnt
31	139976	Bracket Support Fender
37	17490508	Screw Thdrol 5/16-18 x 1/2
38	175710	Bracket Asm. Pivot Mower Rear
39	174714	Bracket Pivot Laser LT
60	STD533707	Bolt Rdhd Sqnk 3/8-16 Unc x 3/4
64	154798	Dash Lower STLT
74	STD541437	Nut Crownlock 3/8-16 Unc
142	175702	Plate Reinforcement STLT
143	<b>186689</b>	Bracket Swaybar Chassis
144	175582	Bracket Pnt Footrest STLT
145	156524	Rod Pivot Chassis/Hood
159	<b>155123X428</b>	Cupholder
166	171875	Screw HWHD Hi-Lo #13-16 x 3/4
206	170165	Bolt Shoulder 5/16-18 TT
207	17670508	Screw Thdrol 5/16-18 x 1/2
208	17670608	Screw Thdrol 3/8-16 x 1/2
209	17000612	Screw Hexwsh Thdr 3/8-16 x 3/4
212	175143	Insert Lens Reflective
- -	5479J	Plug Button

**NOTE:** All component dimensions given in U.S. inches  
1 inch = 25.4 mm

# REPAIR PARTS

## TRACTOR -- MODEL NUMBER 944.604881

### DRIVE

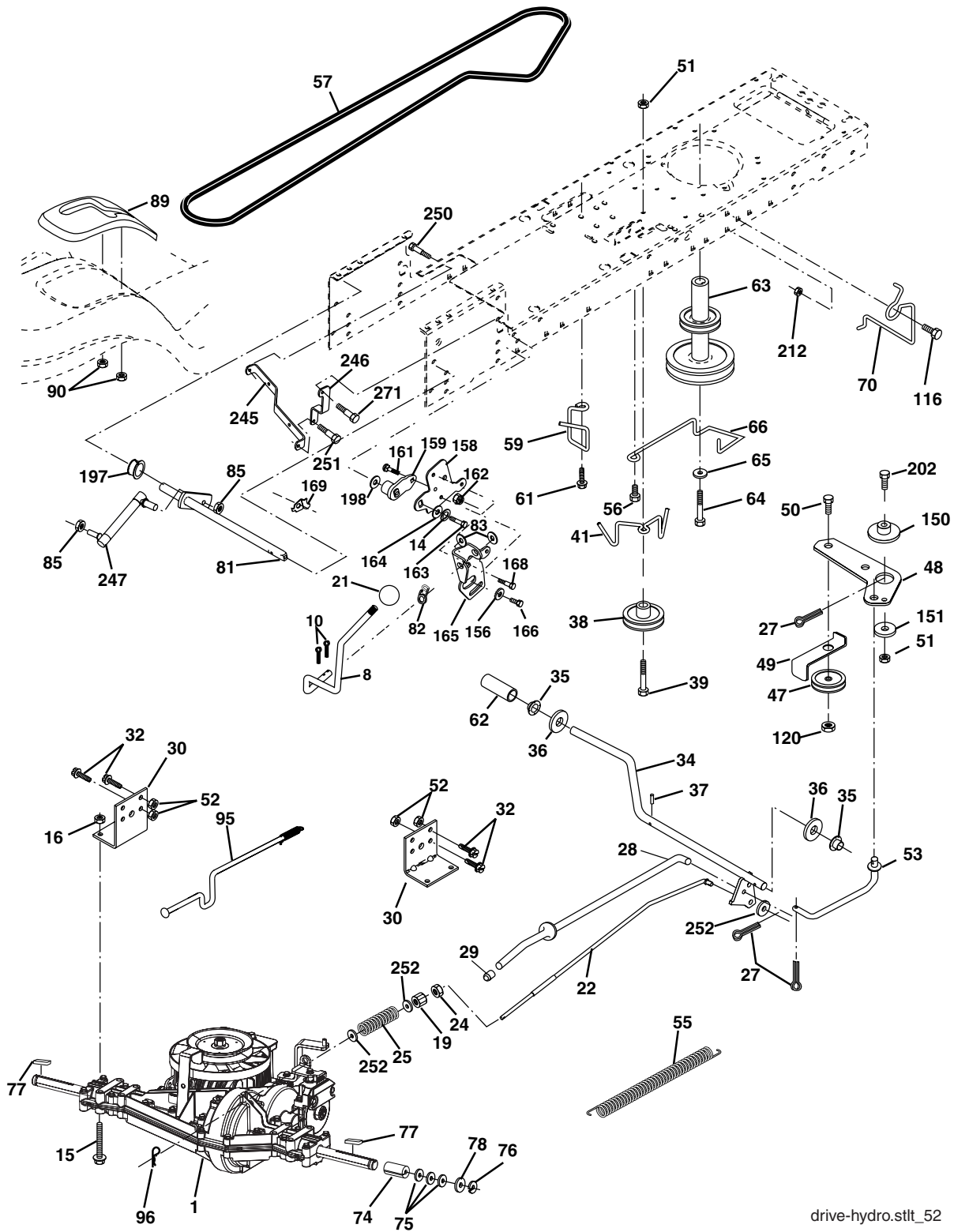

drive-hydro.stlt\_52

# REPAIR PARTS

## TRACTOR - - MODEL NUMBER 944.604881

### DRIVE

KEY PART NO.	NO.	DESCRIPTION	KEY PART NO.	NO.	DESCRIPTION
1	-----	Transaxle (See Breakdown) Peerless LTH2000	74	137057	Spacer Axle
8	165866	Rod Shift Fender Adjust LT	75	121749X	Washer 25/32 x 1 1/4 x 16 Ga
10	STD561210	Pin Cotter 1/8 x 1 Cad	76	STD581075	E-ring #5133-75
14	10040400	Washer Lock Hvy Helical 1/4	77	123583X	Key Square 2 0 x 1845/ 1865
15	74490544	Bolt Hex 5/16-18 Gr. 5	78	121748X	Washer 25/32 x 1-5/8 x 16 Ga
16	STD541431	Nut Lock Hx w/Ins 5/16-18 Unc	81	<b>178139</b>	Shaft Asm Cross
19	STD541437	Nut Lock 3/8-16 Unc	82	165711	Spring Torsion T/a
21	130564	Knob	83	19171216	Washer 17/32 x 3/4 x 16 Ga
22	178141	Rod Brake	85	150360	Nut Lock Center 1/4 - 28 FNTHD
24	STD541237	Nut Hex Jam 3/8-16 Unc	89	164890X428	Console Shift STLT
25	106888X	Spring Rod Brake 2 00 Zinc	90	124346X	Nut Self-thd Wsh-hd 1/4 Zinc
27	STD561210	Pin Cotter 1/8 x 3/4 Cad	95	178134	Disconnect Asm Rod Bypass LTH
28	175765	Rod Brake Parking LT/YT	96	4497H	Retainer Spring
29	71673	Cap Brake Parking	116	72140608	Bolt Rdhd Sq Neck 3/8-16 x 1
30	169592	Bracket Mtg Transaxle	120	73900600	Nut Lock Flg 3/8-16 Unc
32	STD523107	Bolt Hex Hd 5/16-18 Unc x 3/4	150	175456	Bushing Retainer
34	175578	Shaft Asm Pedal Foot	151	19133210	Washer 13/32 x 2 x 10
35	120183X	Bearing Nylon Blk 629 Id	156	166002	Washer Srrted 5/16 ID x 1 x .125
36	STD551062	Washer 21/32 x 1 x 16 Ga	158	165589	Bracket Shift Mount
37	STD571810	Pin Roll 3/16 x 1"	159	183900	Hub Shift
38	179114	Pulley Idler Flat	161	72140406	Bolt Rdhd Sqnk 1/4-20 x 3/4 Gr. 5
39	74760648	Bolt Fin Hex 3/8-16 Unc x 3	162	73680400	Nut Crownlock 1/4-20 Unc
41	175556	Keeper Belt Idler	163	74780416	Bolt Hex Fin 1/4-20 Unc x 1 Gr. 5
47	127783	Pulley Idler V Groove Plastic	164	<b>19091210</b>	Washer 9/32 x 3/4 x 10 Ga.
48	154407	Bellcrank Asm	165	165623	Bracket Pivot Lever
49	123205X	Retainer Belt Style Spring	166	166880	Screw 5/16-18 x 5/8
50	72110612	Bolt Hex Hd 3/8-16 Unc x 1-1/2	168	165492	Bolt Shoulder 5/16-18 x .561
51	STD541437	Nut Crownlock 3/8-16 Unc	169	165580	Plate Fastening LT
52	STD541431	Nut Crownlock 5/16-18 Unc	197	169613	Nyliner Snap-In
53	105710X	Link Clutch	198	169593	Washer Nyliner
55	105709X	Spring Return Clutch 6 75	202	72110614	Bolt Carriage 3/8-16 x 1-3/4 Gr. 5
56	17060620	Screw 3/8-16 x 1-1/4	212	145212	Nut Hexflange Lock
57	178138	V-Belt Ground Drive	245	178122	Strap Torque LH LTH2000
59	169691	Keeper Belt Span Ctr	246	178121	Strap Torque RH LTH2000
61	17120614	Screw 3/8-16 x .875	247	181462	Link Shift Transaxle LTH2000
62	8883R	Cover Pedal Blk Round	250	<b>17000612</b>	Screw 3/8-16 x 3/4
63	175410	Engine Pulley LT/YT	251	17060516	Screw 5/16-18 x 1
64	173937	Bolt Hex	252	19131616	Washer 13/32 x 1 x 16 Ga.
65	STD551143	Washer Lock Hvy Hlcl Spr 7/16			
66	154778	Keeper Belt Engine Foolproof			
70	134683	Guide Belt Mower Drive RH			

**NOTE:** All component dimensions given in U.S. inches  
1 inch = 25.4 mm

# REPAIR PARTS

TRACTOR - - MODEL NUMBER 944.604881

## STEERING ASSEMBLY

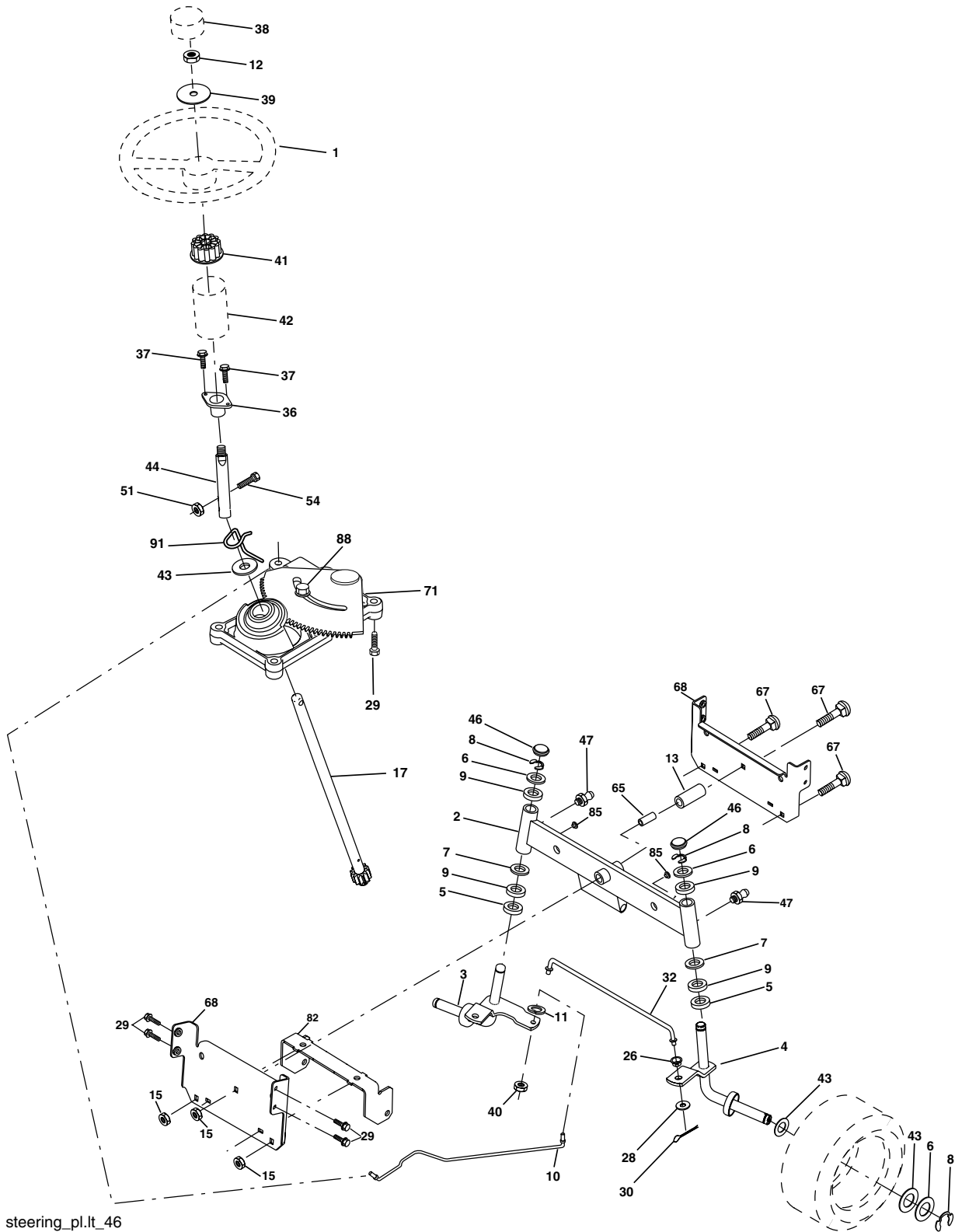

steering\_pl.lt\_46

# REPAIR PARTS

## TRACTOR - - MODEL NUMBER 944.604881

### STEERING ASSEMBLY

KEY PART NO.	NO.	DESCRIPTION
1	139768	Wheel Steering
2	175131	Axle Asm
3	169840	Spindle Asm LH
4	169839	Spindle Asm RH
5	6266H	Bearing Race Thrust Harden
6	121748X	Washer 25/32 x 1-5/8 x 16 Ga
7	19272016	Washer 27/32 x 1-1/4 x 16 Ga.
8	12000029	Ring Klip #t5304-75
9	3366R	Bearing
10	175121	Link Drag Extended Stamp
11	STD551137	Washer Lock Hvy Hlcl Spr 3/8
12	73940800	Nut Hex Jam Toplock 1/2-20 UNF
13	136518	Bearing Axle STLT/GT
15	145212	Nut Hex Flange Lock
17	180641	Shaft Asm Strg
26	126847X	Bushing Link Drag
28	19131416	Washer 13/32 x 7/8 x 16 Ga.
29	<b>17000612</b>	Screw Thdrol 3/8-16 x 3/4
30	76020412	Pin Cotter 1/8 x 3/4
32	130465	Rod Tie Wire Form 19 75 Mech
36	155099	Bushing Strg
37	152927	Screw
38	139769	Insert Cap Strg Wh
39	19183812	Washer 9/16 x 2 3/8 x 12 Ga.
40	STD541537	Lock nut
41	<b>186737</b>	Adaptor Wheel Strg
42	145054X428	Boot Steering Shaft
43	121749X	Washer 25/32 x 1 1/4 x 16 Ga
44	180640	Extension Steering Shaft
46	121232X	Cap Spindle
47	183226	Fiting Grease
51	73540400	Nut Crownlock 1/4-28
54	71130420	Bolt Hex 1/4-28 UNF x 1-1/4 Gr.8
65	160367	Spacer Axle
67	<b>72110618</b>	Bolt Rdhd Sq 3/8-16 Unc x 2-1/4
68	169827	Axle, Brace
71	175146	Steering Asm
82	169835	Bracket Susp. Chassis Front
85	133835	Fastner
88	175118	Shoulder Bolt 7/16-20
91	175553	Clip Steering

**NOTE:** All component dimensions given in U.S. inches  
1 inch = 25.4 mm

# REPAIR PARTS

## TRACTOR - - MODEL NUMBER 944.604881

### SEAT ASSEMBLY

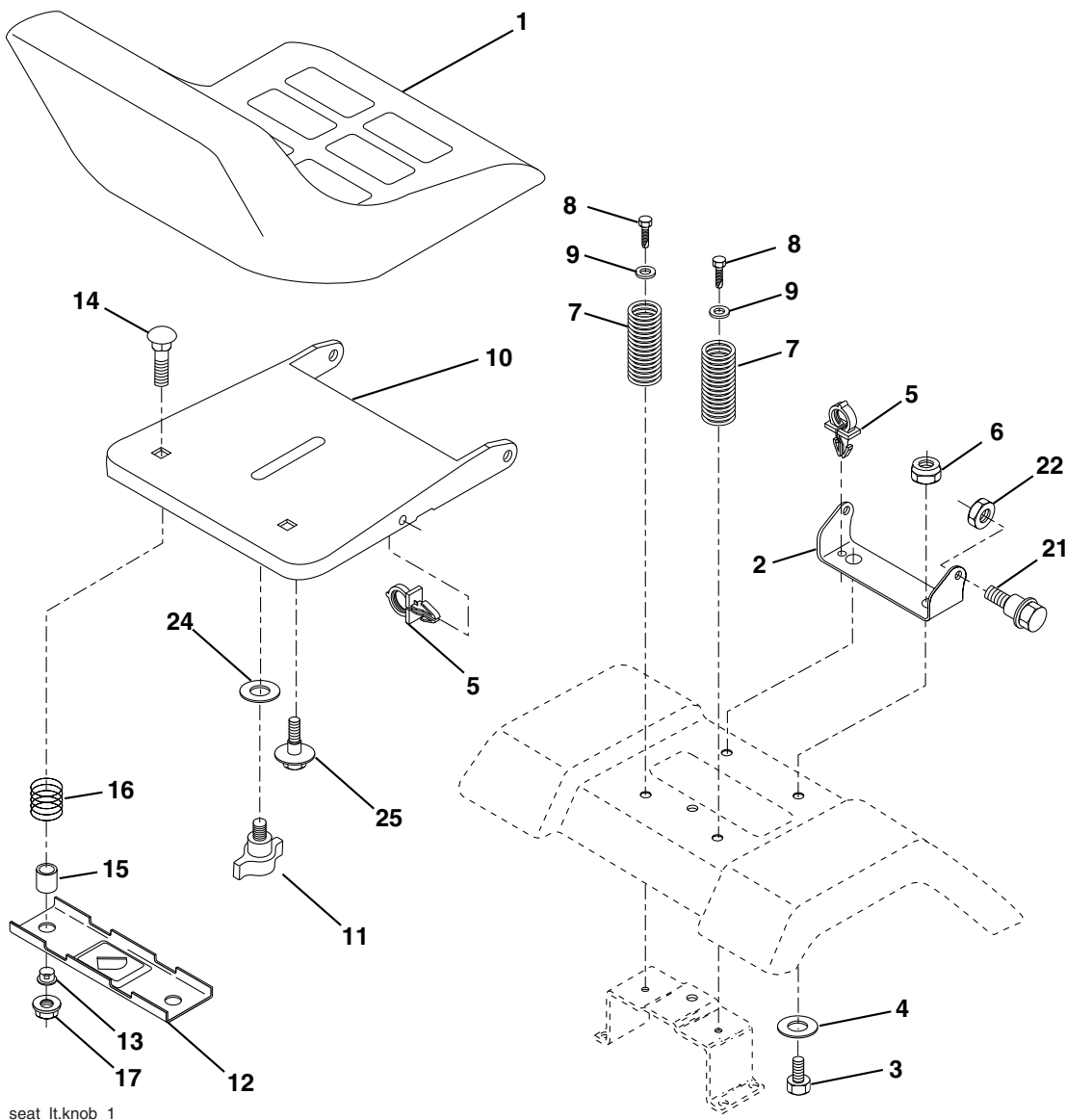

seat\_lt.knob\_1

KEY NO.	PART NO.	DESCRIPTION
1	140122	Seat
2	140551	Bracket Pivot Seat 8 720
3	71110616	Bolt Fin Hex 3/8-16 Unc x 1
4	19131610	Washer 13/32 x 1 x 10 Ga
5	145006	Clip Push-In
6	STD541437	Nut Hex w/Ins. 3/8-16 Unc
7	124181X	Spring Seat Cprsn 2 250 Blk Zi
8	17000616	Screw 3/8-16 x 1-1/2
9	19131614	Washer 13/32 x 1 x 14 Ga.
10	182493	Pan Seat
11	166369	Knob Seaat 1/2-13 Unc Blk
12	121246X	Bracket Mounting Switch

KEY NO.	PART NO.	DESCRIPTION
13	121248X	Bushing Snap Blk Nyl 50 Id
14	72050412	Bolt Rdhd Sqnk 1/4-20 x 1-1/2
15	134300	Spacer Split 28 x 96 Yel Zinc
16	121250X	Spring Cprsn 1 27 Blk Pnt
17	123976X	Nut Lock 1/4 Lge Flg Gr 5 Zinc
21	171852	Bolt Shoulder 5/16-18 Unc
22	STD541431	Nut Hex Lock W/Ins 5/16-18
24	19171912	Washer 17/32 x 1-3/16 x 12 Ga.
25	127018X	Bolt Shoulder 5/16-18 x .62

**NOTE:** All component dimensions given in U.S. inches  
1 inch = 25.4 mm

# REPAIR PARTS

## TRACTOR - - MODEL NUMBER 944.604881

### DECALS

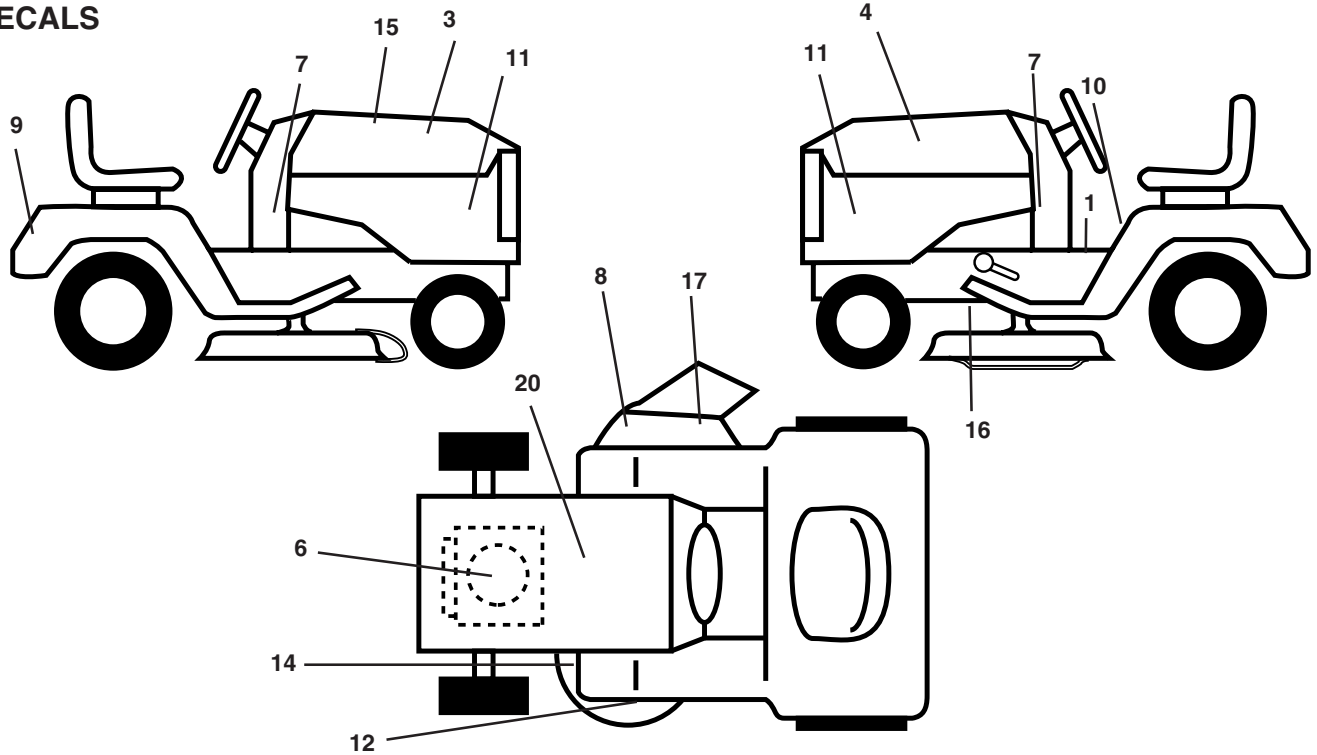

KEY NO.	PART NO.	DESCRIPTION
1	157032	Decal Fend STLT Oper
3	184728	Decal Hood RH
4	184729	Decal Hood LH
6	181882	Decal HP Engine
7	183827	Decal Dash Pnl
8	170563	Decal Warning
9	184899	Decal Craftsman
10	157140	Decal Fender Danger Eng/Fr
11	184730	Decal Hood Side Panel
12	172331	Decal Deck
14	160396	Decal V-Belt Schematic

KEY NO.	PART NO.	DESCRIPTION
15	187624	Decal Replacement Parts
16	146046	Decal V-Belt Drive Sch
17	179128	Decal Bat "B" "42"
20	149517	Decal Bat Dan/Psn
--	178392	Decal Chassis Disconnect
--	<b>184310X428</b>	Pad Footrest LH STLT
--	<b>184311X428</b>	Pad Footrest RH STLT
--	138311	Decal Handle Lft Height Adjust
--	<b>188216</b>	Manual Owner's (English)
--	<b>188217</b>	Manual Owner's (French)

### WHEELS & TIRES

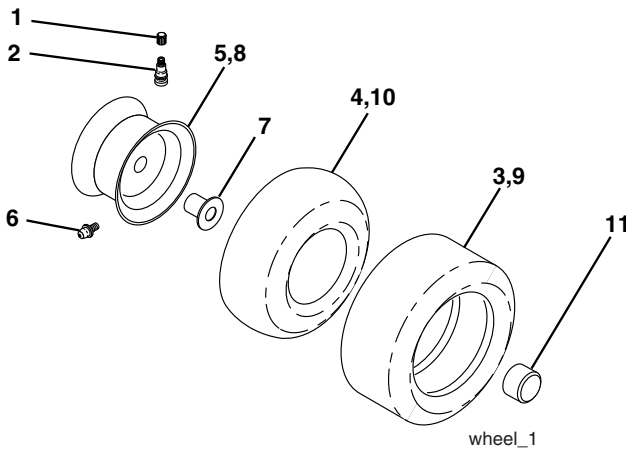

KEY NO.	PART NO.	DESCRIPTION
1	59192	Cap Valve Tire
2	65139	Stem Valve
3	106222X	Tire F Ts 15 X 6 0 - 6 Service
4	59904	Tube Front (Service Item Only)
5	106732X624	Rim Asm 6"front Service
6	278H	Fitting Grease (Front Wheel Only)
7	9040H	Bearing Flange (Front Wheel Only)
8	106108X624	Rim Asm 8"rear Service
9	122082X	Tire R Ts 20x10-8 C Service
10	7152J	Tube Rear (Service Item Only)
11	104757X428	Cap Axle Blk 1 50 X 1 00
--	144334	Sealant, Tire ( 10 oz. Tube)

**NOTE:** All component dimensions given in U.S. inches  
1 inch = 25.4 mm

# REPAIR PARTS

TRACTOR -- MODEL NUMBER 944.604881

## ENGINE

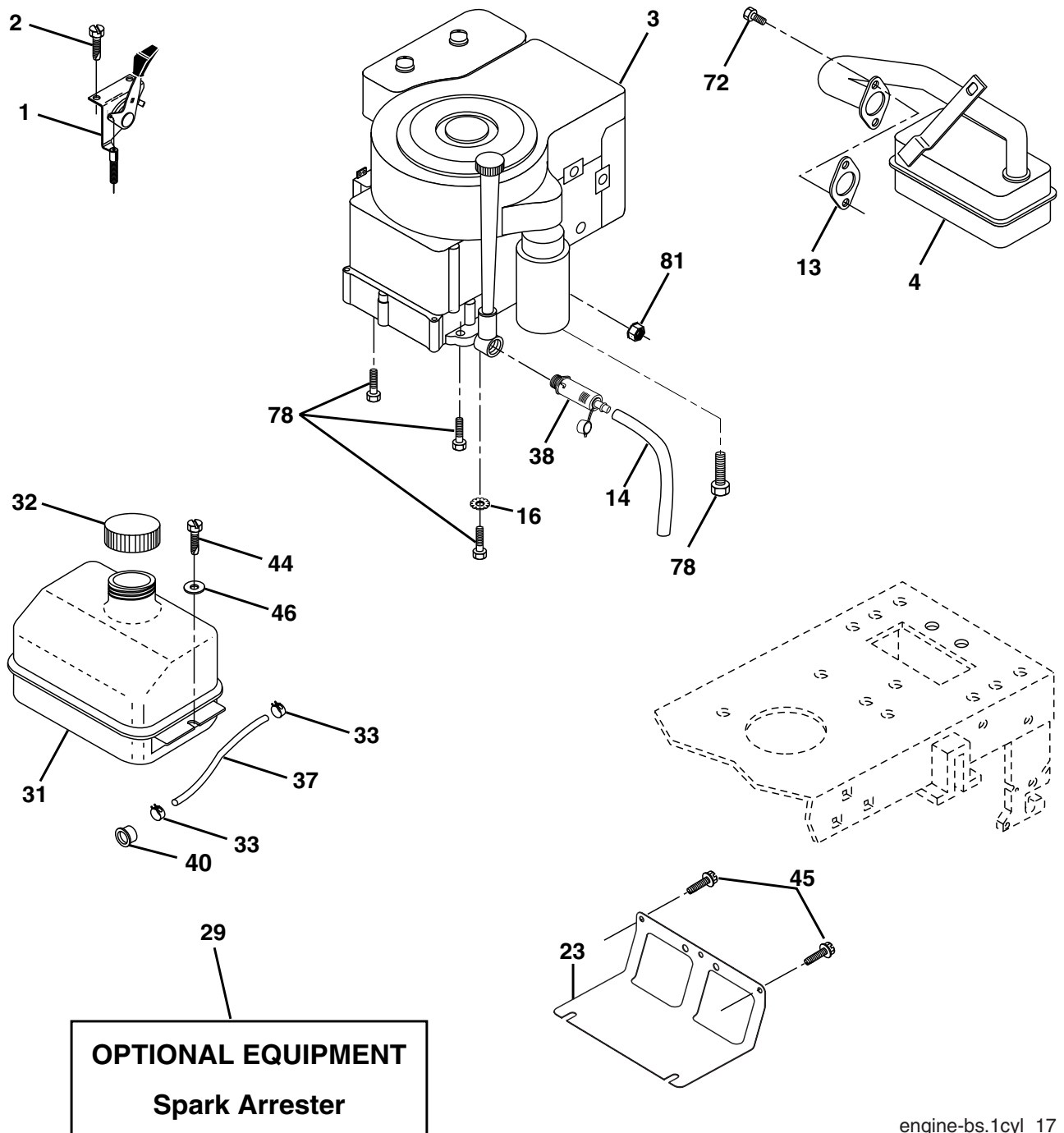

engine-bs.1cyl\_17



# REPAIR PARTS

## TRACTOR - - MODEL NUMBER 944.604881

### ENGINE

KEY NO.	PART NO.	DESCRIPTION
1	170545	Control Throttle Paddle
2	17720408	Screw Hex Thd Cut 1/4-20 x 1/2
3	-----	Engine (See Breakdown) B&S Model 31H777-0202-E1
4	137352	Muffler Exhaust
13	165291	Gasket
14	148456	Tube Drain Oil Easy
16	STD551237	Washer Lock Ext Tooth 3/8
23	169837	Shield BRN/DBR Guard
29	137180	Arrestor Spark
31	184900	Tank Fuel
32	140527	Cap Fuel
33	123487X	Clamp Hose Blk
37	137040	Line Fuel
38	181654	Plug Drain Oil Easy
40	124028X	Bushing
44	17670412	Screw 1/4-20 x 3/4
45	17000612	Screw Hex Wsh Thdrol 3/8-16 x 3/4
46	19091416	Washer 9/32 x 7/8 x 16 Ga.
72	<b>183906</b>	Screw 5/16-18 x 1
78	17060620	Screw 3/8-16 x 1-1/4 SMGML Tap/R
81	73510400	Nut Keps Hex 1/4-20 Unc

**NOTE:** All component dimensions given in U.S. inches  
1 inch = 25.4 mm

# REPAIR PARTS

TRACTOR - - MODEL NUMBER 944.604881

## MOWER DECK

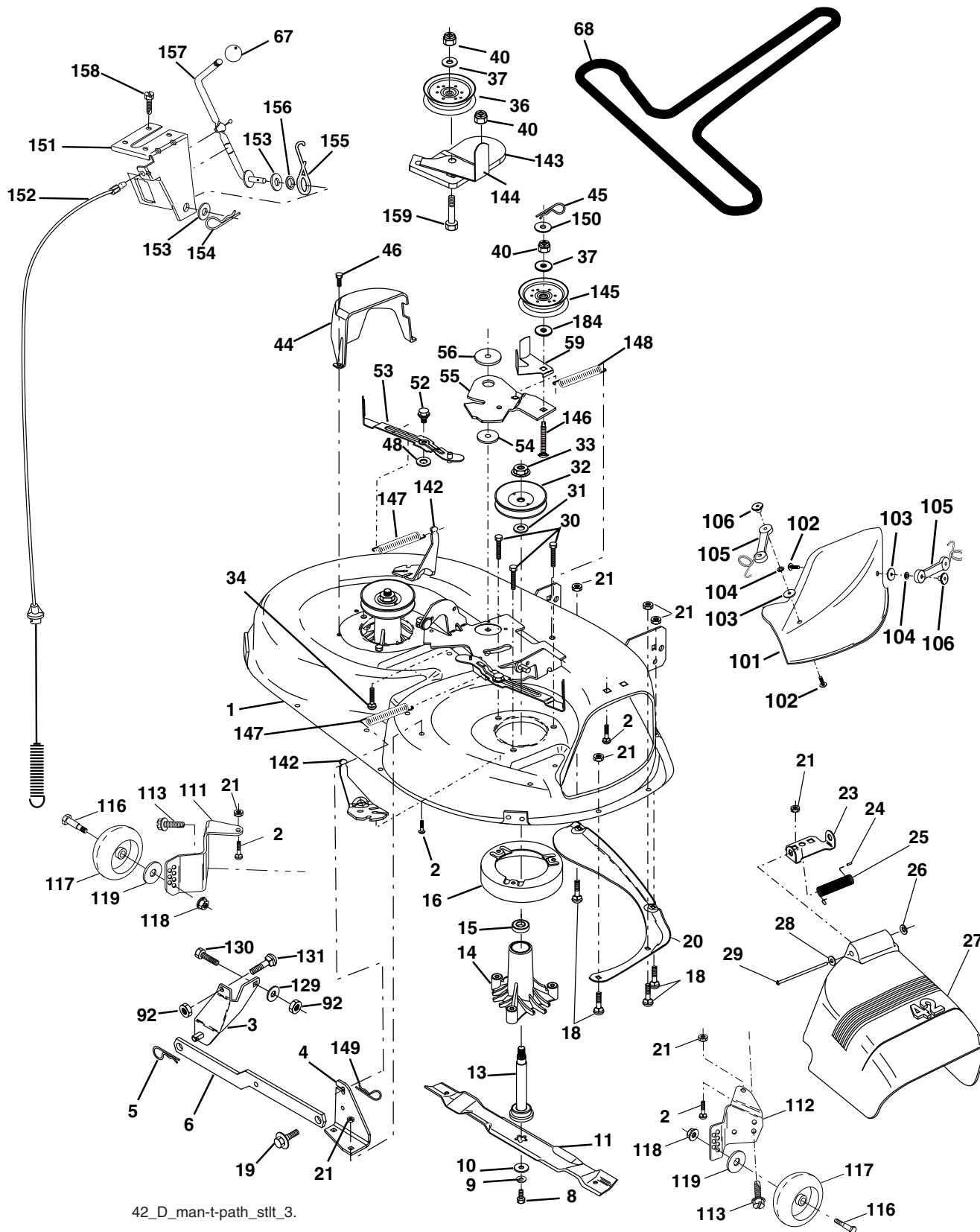

42\_D\_man-t-path\_stlt\_3.

# REPAIR PARTS

## TRACTOR - - MODEL NUMBER 944.604881

### MOWER DECK

KEY NO.	PART NO.	DESCRIPTION	KEY NO.	PART NO.	DESCRIPTION
1	165892	Mower Deck Assembly, 42"	67	149846	Knob Custom
2	STD533107	Bolt	68	144959	V-Belt
3	138017	Bracket Assembly, Sway Bar, Front	92	STD541437	Nut
4	165460	Bracket Sway Bar 38/42" Deck	101	136420	Mulcher Cover
5	STD624008	Retainer Spring	102	71081010	Screw
6	178024	Bar Sway Deck	103	19061216	Washer #10
8	850857	Bolt, Hex 3/8-24 x 1.25 Gr. 8	104	STD551110	Washer, Lock
9	STD551137	Washer, Lock	105	160793	Latch Assembly, Bagger
10	140296	Washer, Hardened	106	2029J	Nut, Weld
		(The following blades are available)	111	179292	Bracket, Gauge, Wheel L.H.
11	134149	Blade, 42" Mulching Std	112	179293	Bracket, Gauge, Wheel R.H.
		(For mulching mowers only)	113	17060510	Screw 3/8-16 x .625
--	139775	Blade, 42" Mulching Premium	114	STD541431	Nut, Hex, Keps 5/16-18 Unc
		(For better wear when mulching)	116	4898H	Bolt, Shoulder
--	138971	Blade, 42" Hi-Lift	117	165746	Wheel, Gauge
		(For bagging or discharging)	118	73930600	Nut, Centerlock 3/8-16
13	137645	Shaft Assembly, Mandrel, Vented	119	STD551037	Washer 3/8 x 7/8 x 14 Gauge
14	128774	Housing, Mandrel, Vented	129	19131312	Washer 13/32 x 13/16 x 12 Ga.
15	110485X	Bearing, Ball, Mandrel	130	STD523710	Bolt, Fin Hex 3/8-16 Unc x 1 Gr. 5
16	174493	Stripper, Vented Mower Deck	131	STD533710	Bolt, Rdhd Sqkn 3/8-16 Unc x 1
18	72140505	Bolt, Carriage 5/16-18 x 5/8	142	165890	Arm Spring Brake Mower
19	132827	Bolt, Shoulder	143	157109	Bracket Arm Idler 42"
20	159770	Baffle, Vortex	144	158634	Keeper Belt 42" Clutch Cable
21	STD541431	Nut Crownlock 5/16-18 Unc	145	165888	Pulley Idler Flat
23	177563	Bracket, Deflector	146	171977	Bolt Carriage Idler
24	105304X	Cap, Sleeve	147	131335	Spring Extension
25	123713X	Spring, Torsion, Deflector	148	169022	Spring Return Idler
26	110452X	Nut, Push	149	165898	Retainer Spring Yellow Zinc
27	130968X428	Shield, Deflector	150	19091216	Washer 9/32 x 3/4 x 16 Ga.
28	19111016	Washer 11/32 x 5/8 x 16 Ga.	151	169670	Bracket Clutch
29	131491	Rod, Hinge	152	169676	Cable Clutch 42 In
30	173984	Screw Thdrol Washer Head	153	169674	Washer Flat 3/8" Type B
31	129963	Washer, Spacer	154	169675	Spring Retainer
32	153535	Pulley, Mandrel	155	169671	Spring Retention Lever
33	178342	Nut, Toplock, Flanged	156	169672	Spacer
34	STD533717	Bolt	157	169669	Rod Clutch
36	131494	Pulley, Idler, Flat	158	17720408	Screw Hex Thd Cut 1/4-20 x 5/8
37	STD551037	Washer 13/32 x 13/16 x 16 Ga.	159	72140614	Bolt Rdhd Sqn 3/8-16 Unc x 1-3/4
40	STD541437	Nut Crownlock 3/8-16 Unc	184	19131410	Washer 13/32 x 7/8 x 10 Ga.
44	140088	Guard, Mandrel, L.H.	--	130794	Mandrel Assembly (Includes Housing, Shaft and Shaft Hardware Only - Pulley Not Included)
45	STD624003	Retainer	--	169583	Replacement Mower Complete (Std. Deck - order separately mulcher cover and gauge wheel components key nos. 101-106 and 116-119)
46	137729	Screw, Thd. Roll 1/4-20 x 5/8			
48	133944	Washer, Hardened			
52	139888	Bolt, Shoulder 5/16-18 Unc			
53	184907	Arm Assembly, Pad, Brake			
54	178515	Washer, Hardened			
55	155046	Arm, Idler			
56	165723	Spacer, Retainer			
59	141043	Guard, TUV Idler			

**NOTE:** All component dimensions given in U.S. inches  
1 inch = 25.4 mm

# REPAIR PARTS

TRACTOR - - MODEL NUMBER 944.604881

## MOWER LIFT

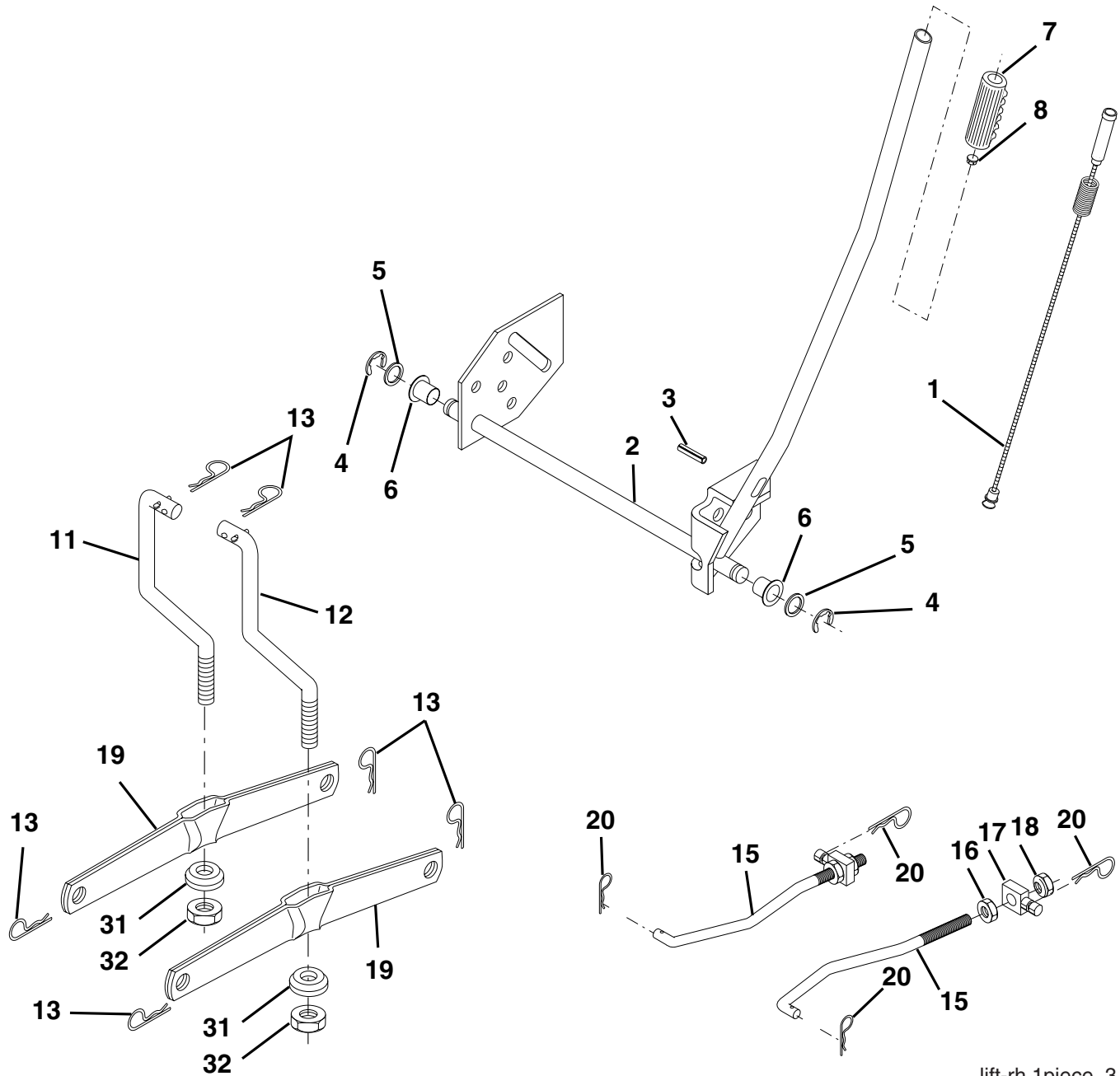

lift-rh.1piece\_3

# REPAIR PARTS

## TRACTOR - - MODEL NUMBER 944.604881

### MOWER LIFT

KEY NO.	PART NO.	DESCRIPTION
1	159460	Wire Asm Inner W/Plunge5r
2	159471	Shaft Asm Lift
3	105767X	Pin Groove
4	STD581062	E Ring #5133-62
5	19211621	Washer 29/32 x 1-1/4 x 21 Ga.
6	120183X	Bearing Nylon Blk .629 ID
7	125631X	Grip Handle Fluted
8	122365X	Button, Plunger
11	139865	Link Lift Lh Fixed Length
12	139866	Link Lift Rh Fixed Length
13	STD624008	Retainer Spring
15	173288	Link Front
16	73350800	Nut Jam Hex 1/2-13 Unc
17	175689	Trunnion Blk Zinc
18	73800800	Nut Lock w/Wsh 1/2-13 Unc
19	139868	Arm Suspension Rear
20	163552	Spring Retainer
31	169865	Bearing Pvt. Lift
32	73540600	Nut Lock 3/8-24

**NOTE:** All component dimensions given in U.S. inches  
1 inch = 25.4 mm

# REPAIR PARTS

## TRACTOR - - MODEL NUMBER 944.604881

### PEERLESS GEAR TRANSAXLE - MODEL NUMBER LTH2000

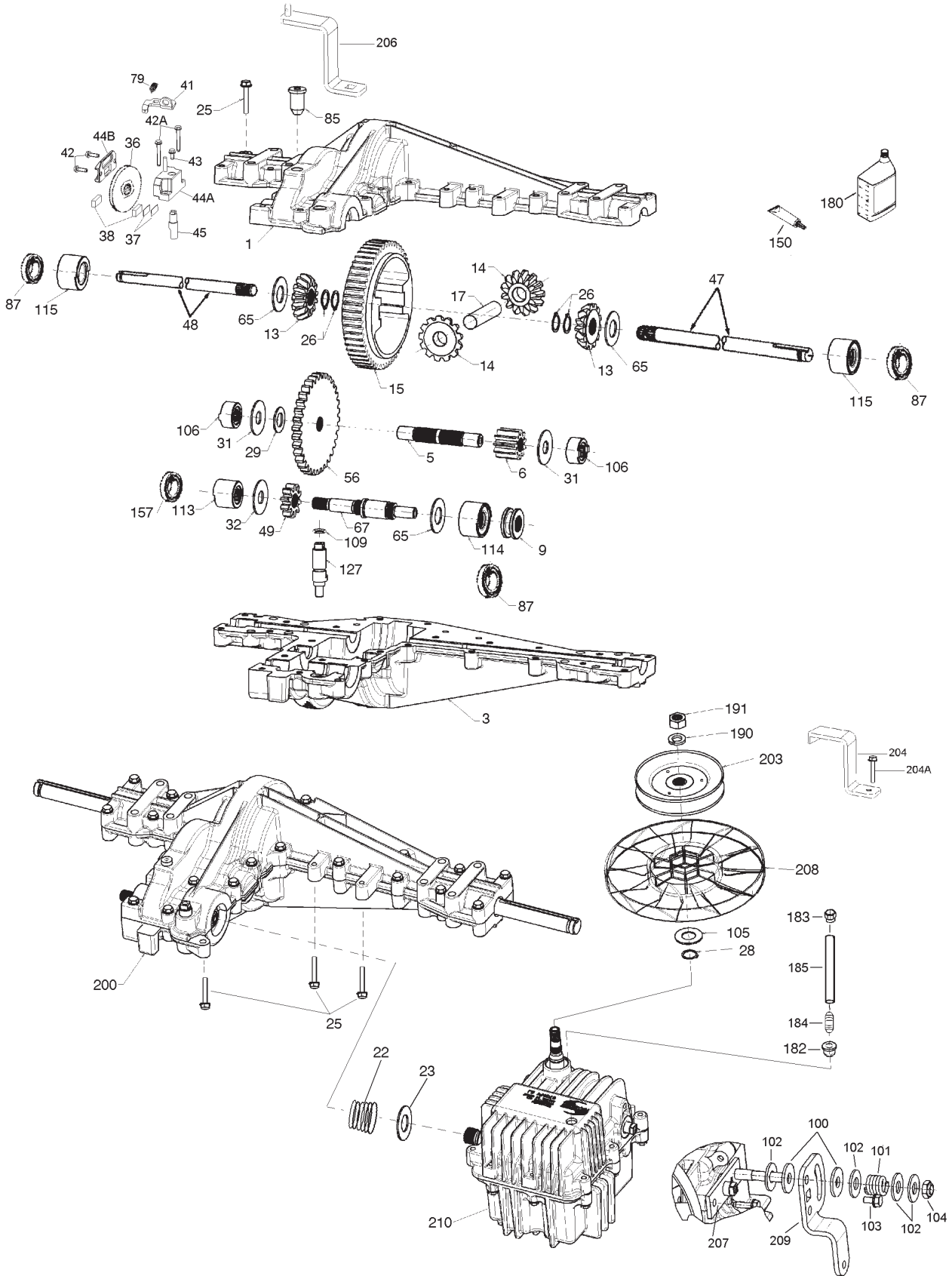

# REPAIR PARTS

## TRACTOR - - MODEL NUMBER 944.604881

### PEERLESS GEAR TRANSAXLE - MODEL NUMBER LTH2000

KEY NO.	PART NO.	DESCRIPTION	KEY NO.	PART NO.	DESCRIPTION
1	772151	Cover L.H.	70	786196	Spacer .625 .765
3	770135	Case	79	792201	Spring
5	776355	Counter Shaft	85	792154	Oil Fill Plug
6	778263	Spur Gear 11T	87	788088A	Oil Seal 3/4"
9	786197	Neutral Sleeve (.572)	99	792141	Washer .377ID .058W
13	778368	Bevel Gear (Incl. 14) (13 Teeth)	100	792200	Snubber Washer
14	778368	Bevel Gear (Incl. 13) (13 Teeth)	101	792199	Snubber Spring .47ID
15	778373	Ring Gear (54 Teeth)	102	792184	Washer .437ID .078W
17	786139	Drive Pin	103	792193	Screw, 1/4-28 x .490
22	792194	Spring	104	792198	Nut, 3/8-24
23	792195	Washer .750 ID	105	780096	Washer .625 ID .057W
25	792073A	Screw 1/4-20 x 1-1/4"	106	786162	Sleeve Assembly
26	792125	Retaining Ring	107	792046	Screw, 1/4-20 x 1"
28	792035	Retaining Ring	109	788104	"O" Ring
29	780065	Washer .627 ID .091W	113	786199	Sleeve Ass'y (Incl. 157)
31	780189	Washer .563 ID .062W	114	786200	Sleeve Ass'y (Incl. 87)
36	790071	Brake Disk	115	786198	Sleeve Assembly (Incl. 87)
37	790007	Brake Pad Plate	127	784384	Shift Lever Ass'y (Incl. 109)
38	799021	Brake Pad	150	788093A	Liquid Gasket RTV Silicon
40	792204	Roll Pin .25	157	788102	Oil Seal 9/16"ID
41	790102	Brake Lever	180	730229	Boil Spec. (80W90)
42	792202	Screw, 1/4-20 x 3/4	182	788103	Grommet
42A	792203	Screw, 1/4-20 x 1-3/4	183	792118	Relief Valve
43	792171	Screw, 10-24 x .500	184	792196	Hose Barb
44A	790100	Inside Brake (Mach)	185	798050	Tubing 1/2 x 5
44B	790099	Outside Brake (Casting)	190	792150	Washer
45	790101	Actuator Rod	191	792151	Nut 7/16-20
47	774869	Axle 16.812	200	794787	Differential (Gear Reduction Drive)
48	774688	Axle 11.625	203	798044	Pulley & Hub Ass'y
49	778378	Spur Gear 18T	206	798055	Disconnect Lever
56	778379	Spur Gear 81T	207	798053	Mounting Plate
65	780195	Washer .750ID .062W	208	798040	Fan
67	776440	Brakeshaft	209	798054	Control Lever
			210	794788	Hydro Module LH Fender Control

# REPAIR PARTS

**TRACTOR - - MODEL NUMBER 944.604881**

**BRIGGS & STRATTON ENGINE - MODEL NUMBER 31H777, TYPE NUMBER 0202-E1**

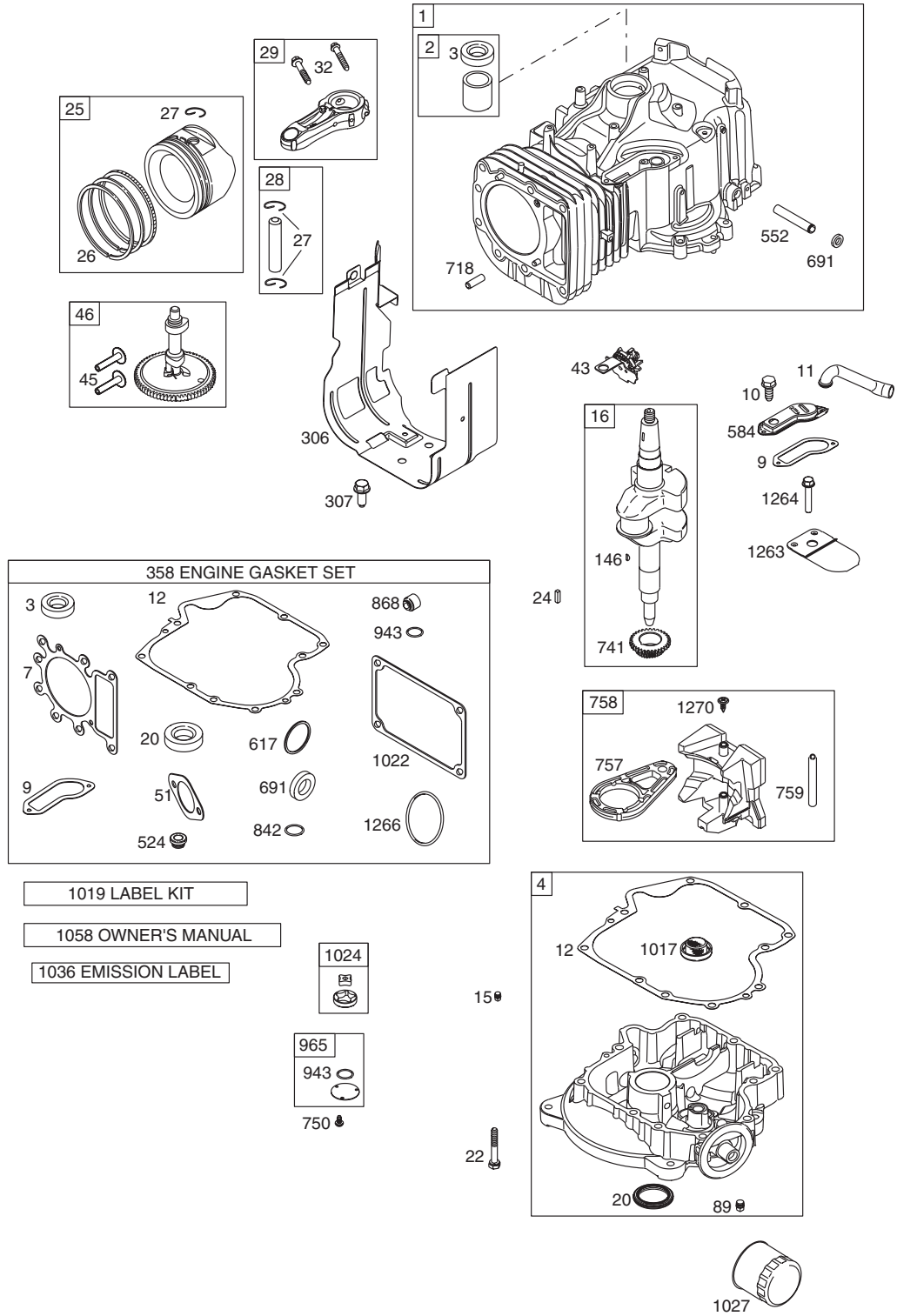



# REPAIR PARTS

**TRACTOR - - MODEL NUMBER 944.604881**

**BRIGGS & STRATTON ENGINE - MODEL NUMBER 31H777, TYPE NUMBER 0202-E1**

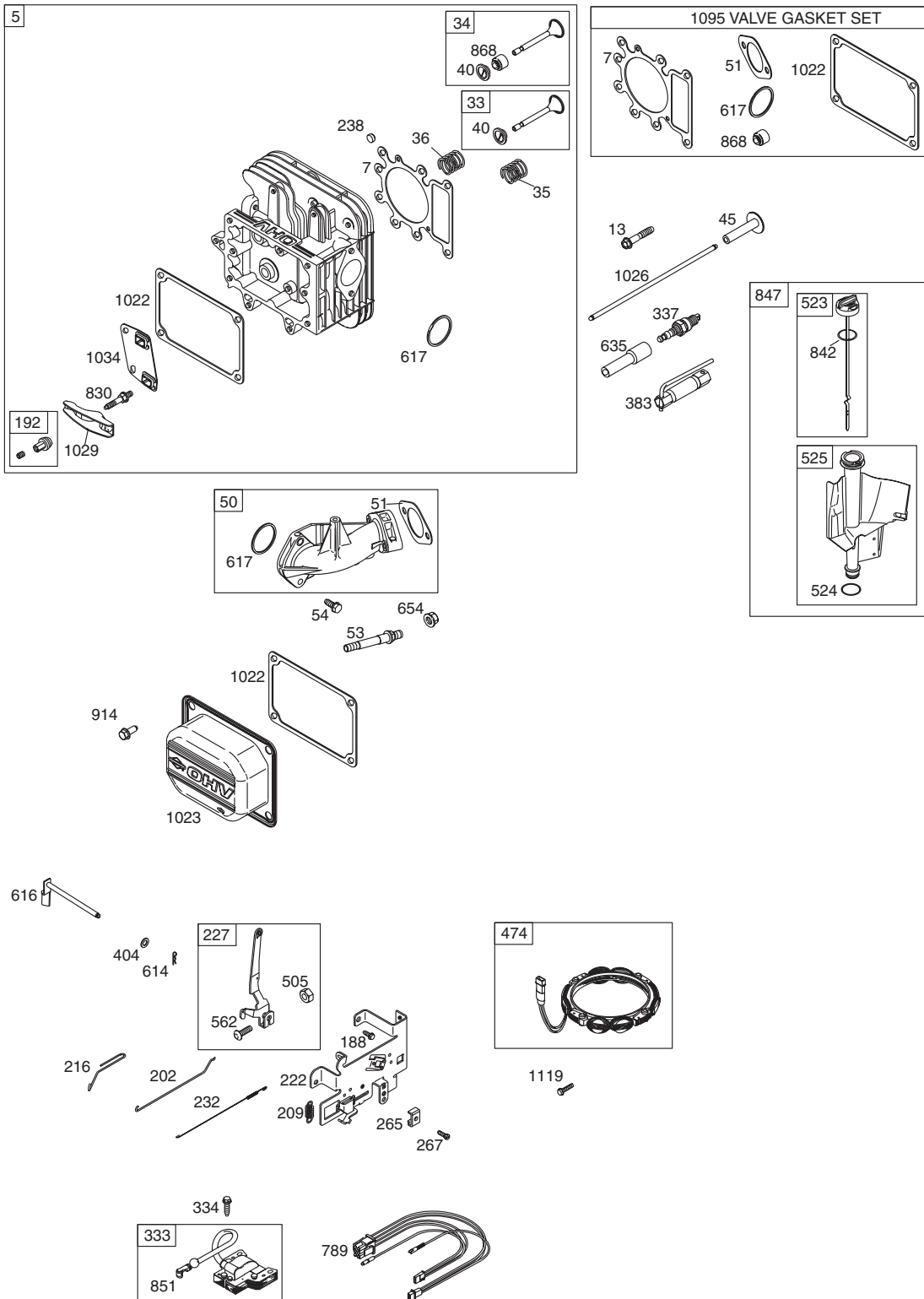

# REPAIR PARTS

## TRACTOR - - MODEL NUMBER 944.604881

### BRIGGS & STRATTON ENGINE - MODEL NUMBER 31H777, TYPE NUMBER 0202-E1

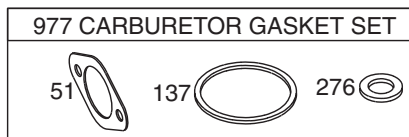
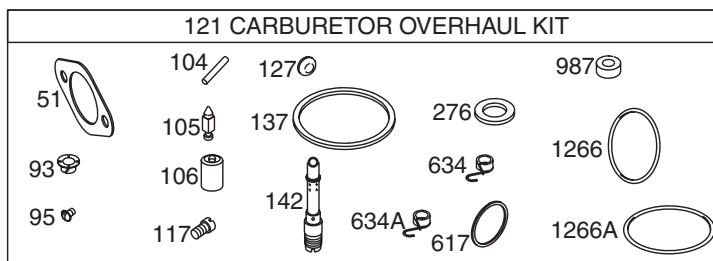
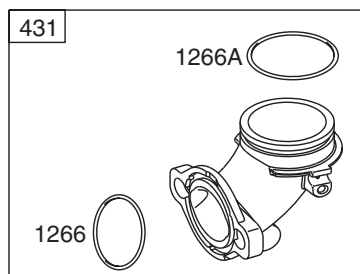
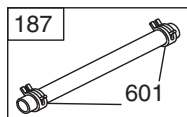
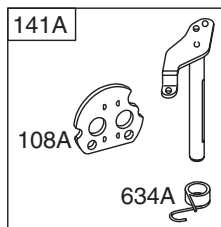
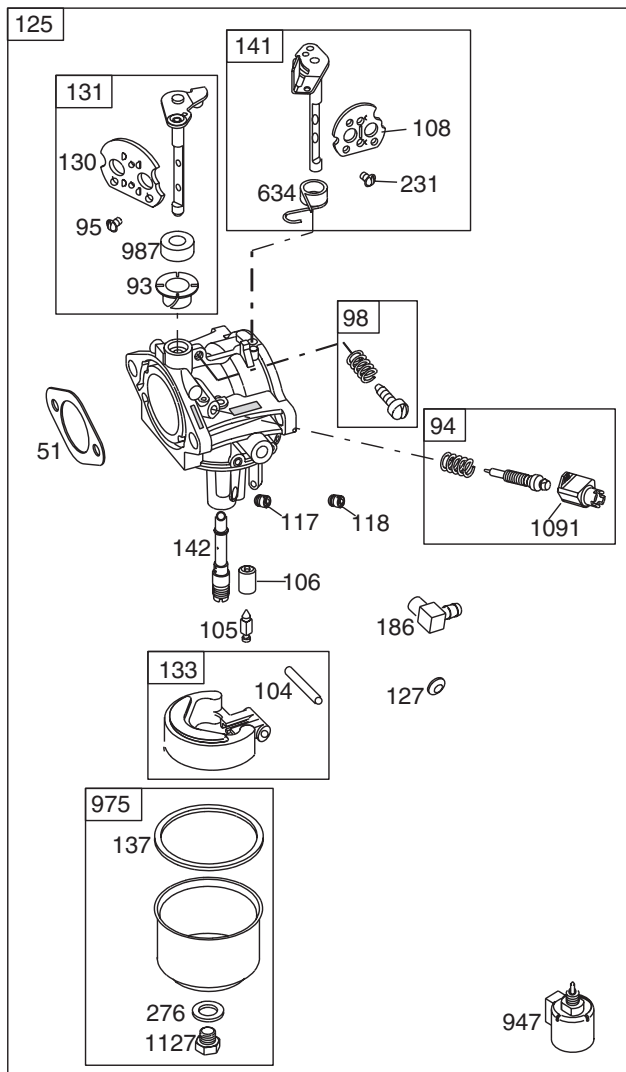

# REPAIR PARTS

TRACTOR - - MODEL NUMBER 944.604881

BRIGGS & STRATTON ENGINE - MODEL NUMBER 31H777, TYPE NUMBER 0202-E1

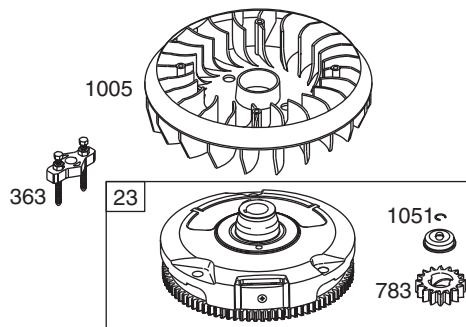
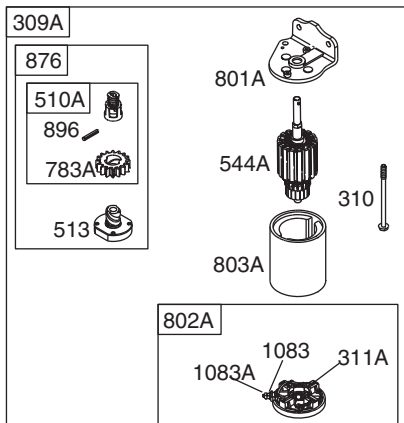
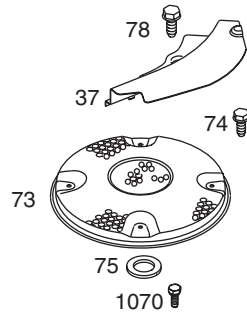
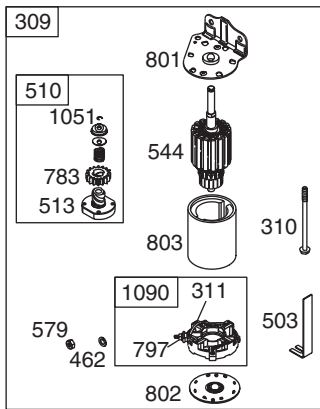
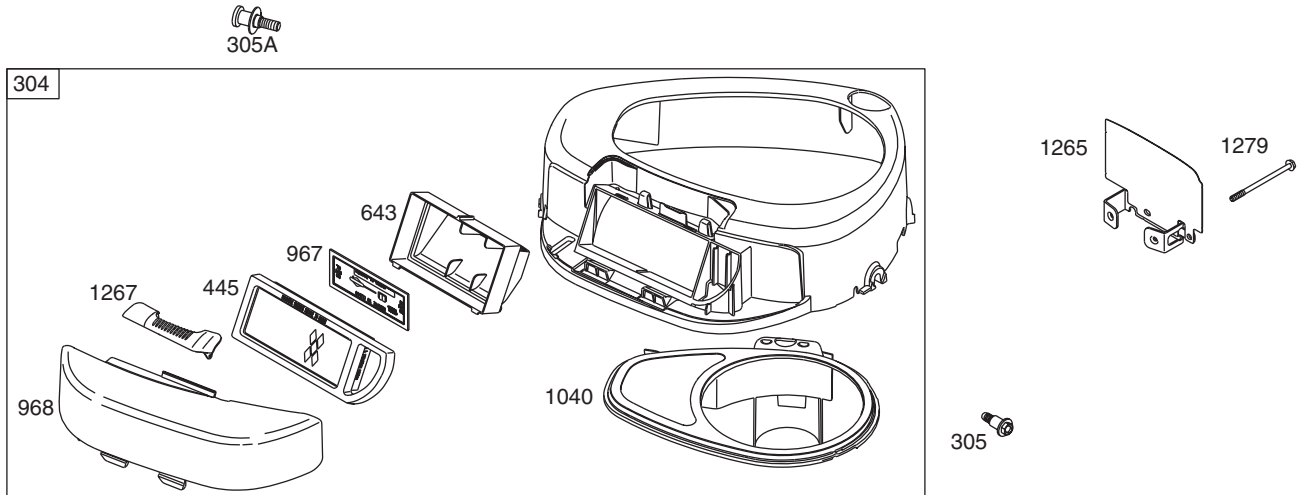

**NOTE: For Replacement Starter Motor, See Reference 309.**

# REPAIR PARTS

## TRACTOR - - MODEL NUMBER 944.604881

### BRIGGS & STRATTON ENGINE - MODEL NUMBER 31H777, TYPE NUMBER 0202-E1

KEY NO.	PART NO.	DESCRIPTION	KEY NO.	PART NO.	DESCRIPTION
1	697174	Cylinder Assembly	108	690464	Valve-Choke (Manual Choke)
2	399265	Kit-Bushing/Seal (Magneto Side)	108A	692344	Valve-Choke (Choke A Matic)
3	391086	• Seal-Oil (Magneto Side)	117	694352	Ø Jet-Main (Standard)
4	697188	Sump-Engine	118	692411	Jet-Main (High Altitude)
5	690188	Head-Cylinder	121	697241	Kit-Carburetor Overhaul
7	692410	•+ Gasket-Cylinder Head	125	697190	Carburetor
9	697109	• Gasket-Breather	127	695005	Plug-Welch
10	697157	Screw (Breather Assembly)	130	691750	Valve-Throttle
11	697113	Tube-Breather	131	494379	Kit-Throttle Shaft
12	697110	• Gasket-Crankcase	133	494381	Float-Carburetor
13	690360	Screw (Cylinder Head)	137	281165	Ø‡ Gasket-Float Bowl
15	690946	Plug-Oil Drain	141	495097	Kit-Choke Shaft (Manual Choke)
16	697127	Crankshaft	141A	495931	Kit-Choke Shaft (Choke A Matic)
20	690947	• Seal-Oil (PTO Side)	142	697140	Ø Nozzle-Carburetor
22	692125	Screw (Crankcase Cover/Sump)	146	691639	Key-Timing
23	693557	Flywheel	186	692317	Connector-Hose
24	222698	Key-Flywheel	187	691050	Line-Fuel (Cut to Required Length)
25	697552	Piston Assembly (Standard)	188	691693	Screw (Control Bracket)
	697555	Piston Assembly (.010" Oversize)	192	691986	Adjuster-Rocker Arm
	697556	Piston Assembly (.020" Oversize)	202	691841	Link-Mechanical Governor
	697557	Piston Assembly (.030" Oversize)	209	692208	Spring-Governor
26	697553	Ring Set (Standard)	216	691840	Link-Choke
	697558	Ring Set (.010" Oversize)	222	694042	Bracket-Control
	697559	Ring Set (.020" Oversize)	227	691374	Lever-Governor Control
	697560	Ring Set (.030" Oversize)	231	691636	Screw (Choke Valve)
27	697100	Lock-Piston Pin	232	691842	Spring-Governor
28	697099	Pin-Piston	238	691843	Cap-Valve
29	697126	Rod-Connecting (Standard)	240	298090	Filter-Fuel
	697263	Rod-Connecting (.020" Undersize)	265	691024	Clamp-Casing
32	692852	Screw (Connecting Rod)	267	695134	Screw (Casing Clamp)
33	495856	Valve-Exhaust	276	692255	Ø‡ Washer-Sealing
34	495857	Valve-Intake	304	697663	Housing-Blower
35	691279	Spring-Valve (Intake)	305	697102	Screw (Blower Housing)
36	691279	Spring-Valve (Exhaust)	305A	697103	Screw (Blower Housing)
37	697108	Guard-Flywheel	306	697107	Shield-Cylinder
40	691752	Retainer-Valve	307	691003	Screw (Cylinder Shield)
43	691968	Slinger-Governor/Oil	309	693551	Motor-Starter
45	690564	Tappet-Valve	309A	--- --	Motor-Starter (For Replacement Starter Motor, See Reference 309)
46	693450	Camshaft			
48	--- --	Short Block (31H777-0202-E2 Replacement Engine-art and Short Block not available at this time)	310	690323	Bolt (Starter Motor)
			311	497608	Brush Set
			311A	395538	Brush Set
50	690193	Manifold-Intake	333	495859	Armature-Magneto
51	692137	•Ø‡+ Gasket-Intake	334	691061	Screw (Magneto Armature)
53	690227	Stud (Carburetor)	337	691043	Plug-Spark
54	691148	Screw (Intake Manifold)	358	697191	Gasket Set-Engine
73	697133	Screen-Rotating	363	19203	Flywheel Puller
74	94986	Screw (Rotating Screen)			RPM Settings:
75	690582	Washer (Flywheel)			Low Speed: 1900-2100
78	691003	Screw (Flywheel Guard)			High Speed: 3000-3200
89	690283	Plug-Oil			
93	690602	Ø Bushing-Throttle Shaft	•		Included in Engine Gasket Set, Key. No. 358
94	498030	Kit-Idle Mixture	Ø		Included in Carburetor Overhaul Kit, Key. No. 121
95	691636	Screw (Throttle Valve)	‡		Included in Carburetor Gasket Set, Key. No. 977
98	495800	Kit-Idle Speed	+		Included in Valve Gasket Set, Key. No. 1095
104	690525	Ø Pin-Float Hinge			
105	231855	Ø Valve-Float Needle			
106	690577	Ø Seat-Inlet			

**NOTE:** All component dimensions given in U.S. inches 1 inch = 25.4 mm

# REPAIR PARTS

## TRACTOR - - MODEL NUMBER 944.604881

### BRIGGS & STRATTON ENGINE - MODEL NUMBER 31H777, TYPE NUMBER 0202-E1

KEY NO.	PART NO.	DESCRIPTION	KEY NO.	PART NO.	DESCRIPTION
383	89838	Wrench-Spark Plug	868	690968	•+ Seal-Valve
404	691691	Washer (Governor Crank)	876	495877	Kit-Pinion Spring
431	697122	Elbow-Intake	896	691641	Pin-Drive Retainer
445	697153	Filter-Air Cleaner Cartridge	914	690960	Screw (Rocker Cover)
462	691261	Washer (Starter Cable)	943	690589	• Seal-O Ring (Oil Pump Cover)
474	696459	Alternator	947	694393	Solenoid-Fuel
503	691532	Strap-Starter	965	499613	Cover-Oil Pump
505	691251	Nut (Governor Control Lever)	967	697015	Filter-Pre Cleaner
510	693699	Drive-Starter	968	697446	Cover-Air Cleaner
510A	497606	Drive-Starter	975	495933	Bowl-Float
513	692024	Clutch-Drive	977	690192	Gasket Set-Carburetor
523	697086	Dipstick	987	691326	Ø Seal-Throttle Shaft
524	691032	• Seal-Dipstick Tube	1005	697111	Fan-Flywheel
525	697184	Tube-Dipstick	1017	690770	Screen-Oil Pump
544	692034	Starter-Armature	1019	697143	Kit-Label
544A	390837	Starter-Armature	1022	272475	•+ Gasket-Rocker Cover
552	697144	Bushing-Governor Crank	1023	692492	Cover-Rocker Arm
562	691119	Bolt (Governor Control Lever)	1024	499054	Pump-Oil
579	691029	Nut (Starter Cable)	1026	692003	Rod-Push (Intake)
584	697112	Cover-Breather Passage	-- --	692011	Rod-Push (Exhaust)
601	95162	Clamp-Hose	1027	697547	Filter-Oil
614	691620	Pin-Cotter	1029	691751	Arm-Rocker
616	692012	Crank-Governor	1034	690822	Guide-Push Rod
617	692138	•Ø Seal-O Ring (Intake Manifold)	1036	695700	Label-Emission
634	690801	Ø Spring/Seal Assembly (Manual Choke)	1040	697142	Plate-Trim
634A	690802	Ø Spring/Seal Assembly (Choke A Matic)	1051	691265	Ring-Retaining
635	691909	Boot-Spark Plug	1058	275038	Owner's Manual
643	697155	Retainer-Air Filter	1070	691058	Screw (Flywheel Fan)
654	690958	Nut (Carburetor)	1083	691626	Nut (Starter Terminal)
691	692407	• Seal-Governor Shaft	1083A	690958	Nut (Starter Terminal)
697	690372	Screw (Drive Cap)	1090	691293	Retainer-Brush
718	690959	Pin-Locating	1091	691333	Cap-Limiter
729	691224	Clip-Wire	1095	690190	Gasket Set-Valve
741	697128	Gear-Timing	1119	691183	Screw (Alternator)
750	691033	Screw (Oil Pump Cover)	1127	691657	Screw (Float Bowl)
757	697607	Link-Counterweight	1263	697124	Reed-Breather
758	697134	Counterweight	1264	697104	Screw (Breather Reed)
759	697392	Pin-Counterweight	1265	697125	Support-Blower Housing
783	693713	Gear-Pinion	1266	691917	•Ø Seal-O Ring (Intake Elbow)
783A	693059	Gear-Pinion	1266A	697123	Ø Seal-O Ring (Intake Elbow)
789	695050	Harness-Wiring	1267	697662	Latch-Blower Housing
797	693167	Nut (Brush Retainer)	1270	697156	Plug-AVS Counterweight
801	691283	Cap-Drive	1279	690960	Screw (Blower Housing Support)
801A	394856	Cap-Drive			RPM Settings:
802	691286	Cap-End			Low Speed: 1900-2100
802A	395537	Cap-End			High Speed: 3000-3200
803	693757	Housing-Starter			
803A	398159	Housing-Starter			• Included in Engine Gasket Set, Key. No. 358
830	691095	Stud (Rocker Arm)			Ø Included in Carburetor Overhaul Kit, Key. No. 121
842	691031	• Seal-O Ring (Dipstick Tube)			‡ Included in Carburetor Gasket Set, Key. No. 977
847	697611	Dipstick/Tube Assembly			+ Included in Valve Gasket Set, Key. No. 1095
851	692424	Terminal-Spark Plug			

**NOTE:** All component dimensions given in U.S. inches 1 inch = 25.4 mm

---

# SERVICE NOTES

---

# SUGGESTED GUIDE FOR SIGHTING SLOPES FOR SAFE OPERATION

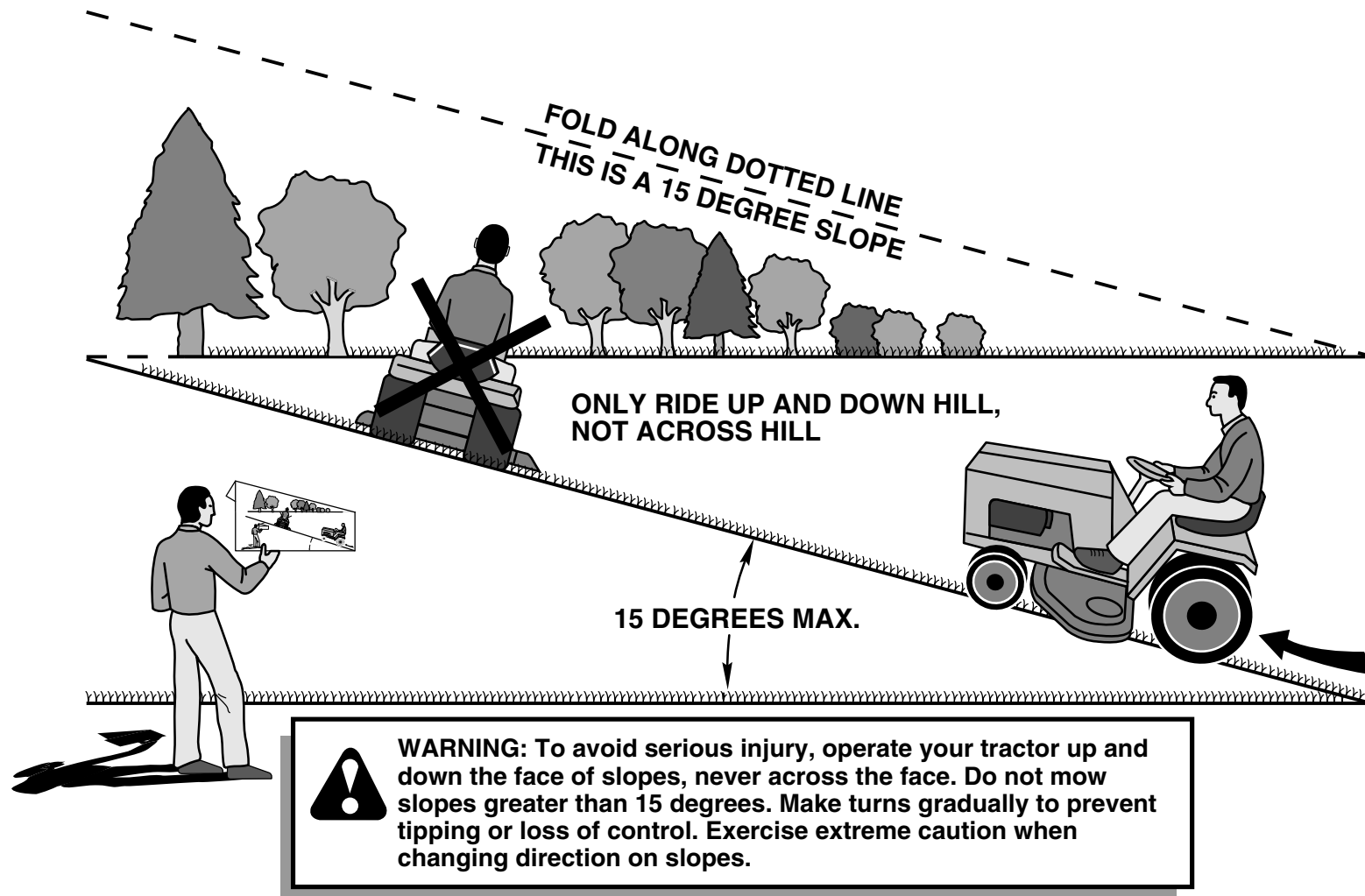

55



**WARNING:** To avoid serious injury, operate your tractor up and down the face of slopes, never across the face. Do not mow slopes greater than 15 degrees. Make turns gradually to prevent tipping or loss of control. Exercise extreme caution when changing direction on slopes.

1. Fold this page along dotted line indicated above.
2. Hold page before you so that its left edge is vertically parallel to a tree trunk or other upright structure.
3. Sight across the fold in the direction of hill slope you want to measure.
4. Compare the angle of the fold with the slope of the hill.

# Get it fixed, at your home or ours!

Just Call:

**1-800-4-MY-HOME®**

(1-800-469-4663)

24 hours a day, 7 days a week

For the repair of major brand appliances **in your own home...**  
no matter who made it, no matter who sold it!

For your nearest **Sears Parts and Service** location,  
to bring in products like vacuums, lawn equipment and electronics.

For **Sears Parts & Service**, to order the replacement parts,  
accessories and owner's manuals that you need to do-it-yourself.

[www.sears.ca](http://www.sears.ca)

---

To purchase or inquire about a Sears Maintenance Agreement, call:

**1-800-361-6665**

9 a.m. – 11 p.m. Mon. – Fri., EST, 9 a.m. – 4 p.m. Sat.

---

Pour service en français:

**1-800-LE-FOYER<sup>MC</sup>**

(1-800-533-6937)

[www.sears.ca](http://www.sears.ca)



® / <sup>TM</sup> Trademarks of Sears, Roebuck and Co. used under license by Sears Canada

<sup>MD</sup> Marque déposée / <sup>MC</sup> Marque de commerce de Sears, Roebuck and Co. utilisée en vertu d'une licence de Sears Canada