

SEARS

**OWNER'S
MANUAL**

**MODEL NO.
944.605931**

**Important:
Read and follow
all Safety Rules
and Instructions
Before Operating
This Equipment**

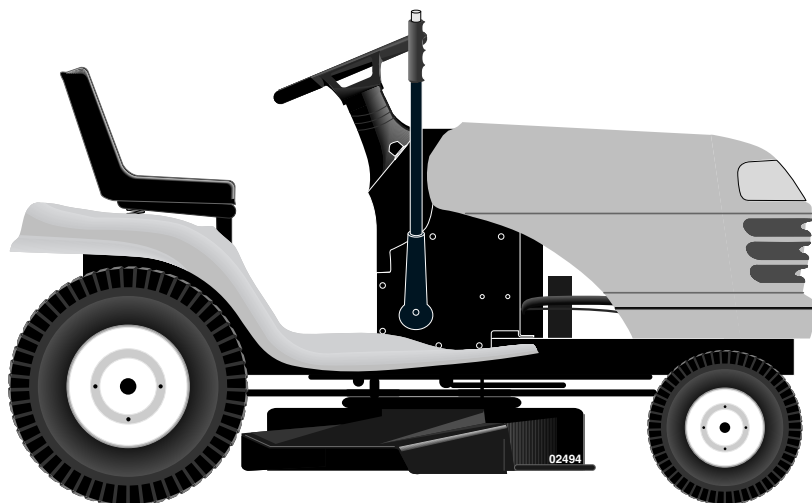

CRAFTSMAN®

23.0 HP ELECTRIC START 42" MOWER AUTOMATIC LAWN TRACTOR

- **Assembly**
- **Operation**
- **Maintenance**
- **Service and Adjustments**
- **Repair Parts**



SAFETY RULES



Safe Operation Practices for Ride-On Mowers

DANGER: THIS CUTTING MACHINE IS CAPABLE OF AMPUTATING HANDS AND FEET AND THROWING OBJECTS. FAILURE TO OBSERVE THE FOLLOWING SAFETY INSTRUCTIONS COULD RESULT IN SERIOUS INJURY OR DEATH.



WARNING: In order to prevent accidental starting when setting up, transporting, adjusting or making repairs, always disconnect spark plug wire and place wire where it cannot contact spark plug.



WARNING: Do not coast down a hill in neutral, you may lose control of the tractor.



WARNING: Tow only the attachments that are recommended by and comply with specifications of the manufacturer of your tractor. Use common sense when towing. Operate only at the lowest possible speed when on a slope. Too heavy of a load, while on a slope, is dangerous. Tires can lose traction with the ground and cause you to lose control of your tractor.

I. GENERAL OPERATION

- Read, understand, and follow all instructions on the machine and in the manual before starting.
- Do not put hands or feet near rotating parts or under the machine. Keep clear of the discharge opening at all times.
- Only allow responsible adults, who are familiar with the instructions, to operate the machine.
- Clear the area of objects such as rocks, toys, wire, etc., which could be picked up and thrown by the blades.
- Be sure the area is clear of bystanders before operating. Stop machine if anyone enters the area.
- Never carry passengers.
- Do not mow in reverse unless absolutely necessary. Always look down and behind before and while backing.
- Never direct discharged material toward anyone. Avoid discharging material against a wall or obstruction. Material may ricochet back toward the operator. Stop the blades when crossing gravel surfaces.
- Do not operate machine without the entire grass catcher, discharge guard, or other safety devices in place and working.
- Slow down before turning.
- Never leave a running machine unattended. Always turn off blades, set parking brake, stop engine, and remove keys before dismounting.
- Disengage blades when not mowing. Shut off engine and wait for all parts to come to a complete stop before cleaning the machine, removing the grass catcher, or unclogging the discharge guard.
- Operate machine only in daylight or good artificial light.
- Do not operate the machine while under the influence of alcohol or drugs.
- Watch for traffic when operating near or crossing roadways.
- Use extra care when loading or unloading the machine into a trailer or truck.
- Always wear eye protection when operating machine.

- Data indicates that operators, age 60 years and above, are involved in a large percentage of riding mower-related injuries. These operators should evaluate their ability to operate the riding mower safely enough to protect themselves and others from serious injury.
- Follow the manufacturer's recommendation for wheel weights or counterweights.
- Keep machine free of grass, leaves or other debris build-up which can touch hot exhaust/engine parts and burn. Do not allow the mower deck to plow leaves or other debris which can cause build-up to occur. Clean any oil or fuel spillage before operating or storing the machine. Allow machine to cool before storage.

II. SLOPE OPERATION

Slopes are a major factor related to loss of control and tip-over accidents, which can result in severe injury or death. Operation on all slopes requires extra caution. If you cannot back up the slope or if you feel uneasy on it, do not mow it.

- Mow up and down slopes, not across.
- Watch for holes, ruts, bumps, rocks, or other hidden objects. Uneven terrain could overturn the machine. Tall grass can hide obstacles.
- Choose a low ground speed so that you will not have to stop or shift while on the slope.
- Do not mow on wet grass. Tires may lose traction. Always keep the machine in gear when going down slopes. Do not shift to neutral and coast downhill.
- Avoid starting, stopping, or turning on a slope. If the tires lose traction, disengage the blades and proceed slowly straight down the slope.
- Keep all movement on the slopes slow and gradual. Do not make sudden changes in speed or direction, which could cause the machine to roll over.
- Use extra care while operating machine with grass catchers or other attachments; they can affect the stability of the machine. Do no use on steep slopes.
- Do not try to stabilize the machine by putting your foot on the ground.
- Do not mow near drop-offs, ditches, or embankments. The machine could suddenly roll over if a wheel is over the edge or if the edge caves in.

III. CHILDREN

Tragic accidents can occur if the operator is not alert to the presence of children. Children are often attracted to the machine and the mowing activity. *Never* assume that children will remain where you last saw them.

- Keep children out of the mowing area and in the watchful care of a responsible adult other than the operator.
- Be alert and turn machine off if a child enters the area.
- Before and while backing, look behind and down for small children.
- Never carry children, even with the blades shut off. They may fall off and be seriously injured or interfere with safe machine operation. Children who have been given rides in the past may suddenly appear in the mowing area for another ride and be run over or backed over by the machine.
- Never allow children to operate the machine.
- Use extra care when approaching blind corners, shrubs, trees, or other objects that may block your view of a child.



SAFETY RULES



Safe Operation Practices for Ride-On Mowers

IV. TOWING

- Tow only with a machine that has a hitch designed for towing. Do not attach towed equipment except at the hitch point.
- Follow the manufacturer's recommendation for weight limits for towed equipment and towing on slopes.
- Never allow children or others in or on towed equipment.
- On slopes, the weight of the towed equipment may cause loss of traction and loss of control.
- Travel slowly and allow extra distance to stop.

V. SERVICE

SAFE HANDLING OF GASOLINE

To avoid personal injury or property damage, use extreme care in handling gasoline. Gasoline is extremely flammable and the vapors are explosive.

- Extinguish all cigarettes, cigars, pipes, and other sources of ignition.
- Use only approved gasoline container.
- Never remove gas cap or add fuel with the engine running. Allow engine to cool before refueling.
- Never fuel the machine indoors.
- Never store the machine or fuel container where there is an open flame, spark, or pilot light such as on a water heater or other appliances.
- Never fill containers inside a vehicle or on a truck or trailer bed with plastic liner. Always place containers on the ground away from your vehicle when filling.
- Remove gas-powered equipment from the truck or trailer and refuel it on the ground. If this is not possible, then refuel such equipment with a portable container, rather than from a gasoline dispenser nozzle.
- Keep the nozzle in contact with the rim of the fuel tank or container opening at all times until fueling is complete. Do not use a nozzle lock-open device.
- If fuel is spilled on clothing, change clothing immediately.
- Never overfill fuel tank. Replace gas cap and tighten securely.

GENERAL SERVICE

- Never operate machine in a closed area.
- Keep all nuts and bolts tight to be sure the equipment is in safe working condition.
- Never tamper with safety devices. Check their proper operation regularly.
- Keep machine free of grass, leaves, or other debris build-up. Clean oil or fuel spillage and remove any fuel-soaked debris. Allow machine to cool before storing.
- If you strike a foreign object, stop and inspect the machine. Repair, if necessary, before restarting.

- Never make any adjustments or repairs with the engine running.
- Check grass catcher components and the discharge guard frequently and replace with manufacturer's recommended parts, when necessary.
- Mower blades are sharp. Wrap the blade or wear gloves, and use extra caution when servicing them.
- Check brake operation frequently. Adjust and service as required.
- Maintain or replace safety and instruction labels, as necessary.



- Be sure the area is clear of bystanders before operating. Stop machine if anyone enters the area.
- Never carry passengers.
- Do not mow in reverse unless absolutely necessary. Always look down and behind before and while backing.
- Never carry children, even with the blades shut off. They may fall off and be seriously injured or interfere with safe machine operation. Children who have been given rides in the past may suddenly appear in the mowing area for another ride and be run over or backed over by the machine.
- Keep children out of the mowing area and in the watchful care of a responsible adult other than the operator.
- Be alert and turn machine off if a child enters the area.
- Before and while backing, look behind and down for small children.
- Mow up and down slopes (15° Max), not across.
- Be alert and turn machine off if a child enters the area.
- Choose a low ground speed so that you will not have to stop or shift while on the slope.
- Avoid starting, stopping, or turning on a slope. If the tires lose traction, disengage the blades and proceed slowly straight down the slope.
- If machine stops while going uphill, disengage blades, shift into reverse and back down slowly.
- Do not turn on slopes unless necessary, and then, turn slowly and gradually downhill, if possible.

TABLE OF CONTENTS

| | |
|---------------------------------|------|
| SAFETY RULES | 2-3 |
| PRODUCT SPECIFICATIONS | 4 |
| WARRANTY | 4 |
| CUSTOMER RESPONSIBILITIES | 4 |
| ASSEMBLY | 6-8 |
| OPERATION | 9-15 |
| MAINTENANCE SCHEDULE | 16 |

| | |
|-------------------------------|------------|
| MAINTENANCE | 16-20 |
| SERVICE AND ADJUSTMENTS | 20-25 |
| STORAGE | 26 |
| TROUBLESHOOTING | 27-28 |
| REPAIR PARTS - TRACTOR | 30-45 |
| REPAIR PARTS - ENGINE..... | 46-50 |
| PARTS ORDERING/SERVICE..... | BACK COVER |

PRODUCT SPECIFICATIONS

| | |
|--|---|
| Gasolina Capacity and type: | 2.0 Gallons Unleaded Regular |
| Oil Type (API-SG-SL): | SAE 30 (above 32°F) SAE 5W-30 (below 32°F) SYNTHETIC below 0°F) |
| Your tractor was shipped from the factory with non-synthetic SAE 10W-30 motor oil. | |
| Oil Capacity: | W/Filter: 64 oz. W/O Filter: 60 oz. |
| Spark Plug: (Gap: 030") | Champion QC12YC |
| Ground Speed (MPH): | Forward: 5.5 Reverse: 2.4 |
| Charging System: | 3 Amps Battery 5 Amps Headlights |
| Battery: | AMP/HR: 35 Min. CCA: 280 Case Size: U1R |
| Blade Bolt Torque: | 27-35 Ft. Lbs. |

CONGRATULATIONS on your purchase of a new tractor. It has been designed, engineered and manufactured to give you the best possible dependability and performance.

Should you experience any problem you cannot easily remedy, please contact your nearest authorized service center/department. We have competent, well-trained technicians and the proper tools to service or repair this tractor.

Please read and retain this manual. The instructions will enable you to assemble and maintain your tractor properly. Always observe the "SAFETY RULES".

MAINTENANCE AGREEMENT

A Maintenance Agreement is available on this product. Contact your nearest Sears store for details.

CUSTOMER RESPONSIBILITIES

- Read and observe the safety rules.
- Follow a regular schedule in maintaining, caring for and using your tractor.
- Follow the instructions under "Maintenance" and "Storage" sections of this owner's manual.

WARNING: This tractor is equipped with an internal combustion engine and should not be used on or near any unimproved forest-covered, brush-covered or grass-covered land unless the engine's exhaust system is equipped with a spark arrester meeting applicable local or state laws (if any). If a spark arrester is used, it should be maintained in effective working order by the operator.

A spark arrester for the muffler is available through your nearest authorized service center/department (See REPAIR PARTS section of this manual).

WARRANTY

LIMITED TWO (2) YEAR WARRANTY ON CRAFTSMAN TRACTOR (RIDING EQUIPMENT)

For two (2) years from date of purchase Sears Canada, Inc. will repair or replace at Sears option free of charge parts which are defective as a result of material or workmanship.

FULL ONE (1) YEAR WARRANTY ON BATTERY

For one (1) year from date of purchase, if any battery included with this riding equipment proves defective in material or workmanship and our testing determines the battery will not hold a charge, Sears will replace the battery at no charge.

COMMERCIAL OR RENTAL USE

Warranty on Riding Equipment used for commercial or rental purposes is limited to ninety (90) days.

This Warranty does **NOT** cover:

1. Pre-delivery set-up.
2. Tire replacement or repair caused by punctures from outside objects (such as nails, thorns, stumps, or glass).
3. Expendable items which become worn during normal use, such as blades, spark plug, air cleaners and belts.
4. Repairs necessary because of operator abuse or negligence, including damaged jackshaft or mandrel and the failure to operate and maintain the equipment according to the instructions contained in the Owner's Manual.

Warranty service is available by returning the Craftsman Riding Equipment to the nearest Sears Service Centre/Department in Canada. This warranty applies only while this product is in use in Canada.

This warranty is in addition to any statutory warranty and does not exclude or limit legal rights you may have but shall run concurrently with applicable provincial legislation. Furthermore, some provinces do NOT allow limitation on how long an implied warranty will last so the above limitations may not apply to you.

SEARS CANADA, INC., TORONTO, ONTARIO M5B 2B8

UNASSEMBLED PARTS

Steering Wheel

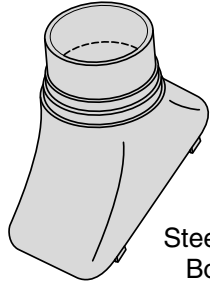
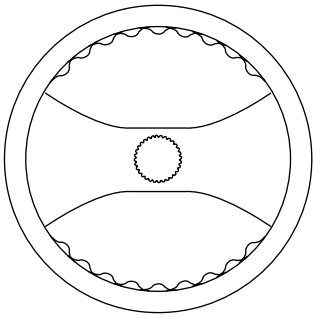

Steering Boot

Steering Extension Shaft

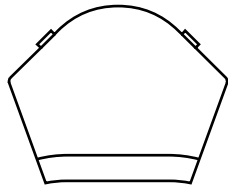

Steering Wheel Insert

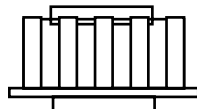

Steering Wheel Adapter

(1) Large Flat Washer

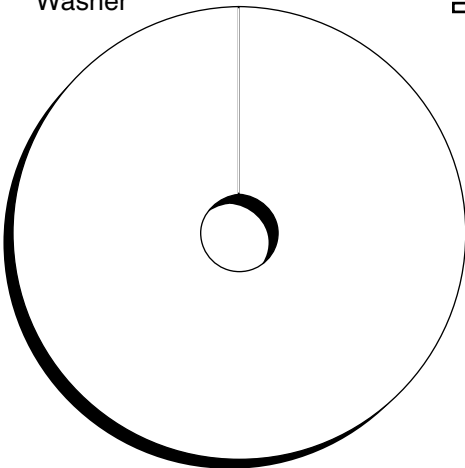

(1) Large Flat Washer

(1) 5/16 Lock Washer

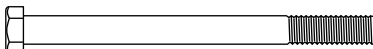

(1) Hex Bolt 5/16-18 x 4

Seat

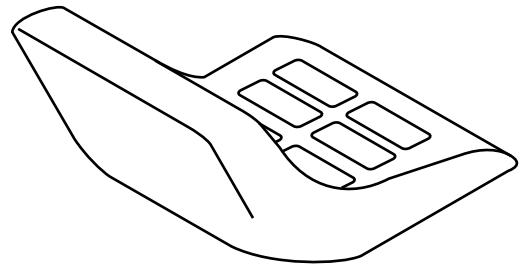

(1) Washer 17/32 x 1-3/16 x 12 Gauge

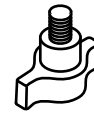

(1) Knob

Battery

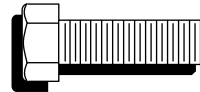

(2) Hex Bolts 1/4-20 x 3/4

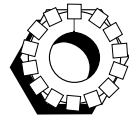

(2) Keps Nuts 1/4-20



(1) Oil Drain Tube

Keys

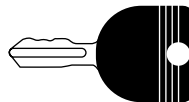

(2) Keys

Slope Sheet

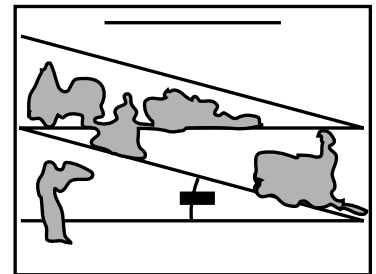

ASSEMBLY

Your new tractor has been assembled at the factory with exception of those parts left unassembled for shipping purposes. To ensure safe and proper operation of your tractor all parts and hardware you assemble must be tightened securely. Use the correct tools as necessary to insure proper tightness.

TOOLS REQUIRED FOR ASSEMBLY

A socket wrench set will make assembly easier. Standard wrench sizes are listed.

- | | |
|-----------------|---------------------|
| (1) 3/4" wrench | Pliers |
| (1) 1/2" wrench | Tire pressure gauge |
| | Utility knife |

When right or left hand is mentioned in this manual, it means when you are in the operating position (seated behind the steering wheel).

TO REMOVE TRACTOR FROM CARTON

UNPACK CARTON

- Remove all accessible loose parts and parts cartons from carton.
- Cut along dashed lines on all four panels of carton. Remove end panels and lay side panels flat.
- Check for any additional loose parts or cartons and remove.

BEFORE REMOVING TRACTOR FROM SKID

ATTACH STEERING WHEEL (See Fig. 1)

ASSEMBLE EXTENSION SHAFT AND BOOT

- Slide extension shaft onto lower steering shaft.
- Place tabs of steering boot over tab slots in dash and push down to secure.

INSTALL STEERING WHEEL

- Position front wheels of the tractor so they are pointing straight forward.
- Remove steering wheel adapter from steering wheel and slide adapter onto steering shaft extension.
- Position steering wheel so cross bars are horizontal (left to right) and slide inside boot and onto adapter.
- Assemble large flat washer, 5/16 lock washer, 5/16 hex bolt and tighten securely.
- Snap steering wheel insert into center of steering wheel.
- Remove protective materials from tractor hood and grill.

IMPORTANT: CHECK FOR AND REMOVE ANY STAPLES IN SKID THAT MAY PUNCTURE TIRES WHERE TRACTOR IS TO ROLL OFF SKID.

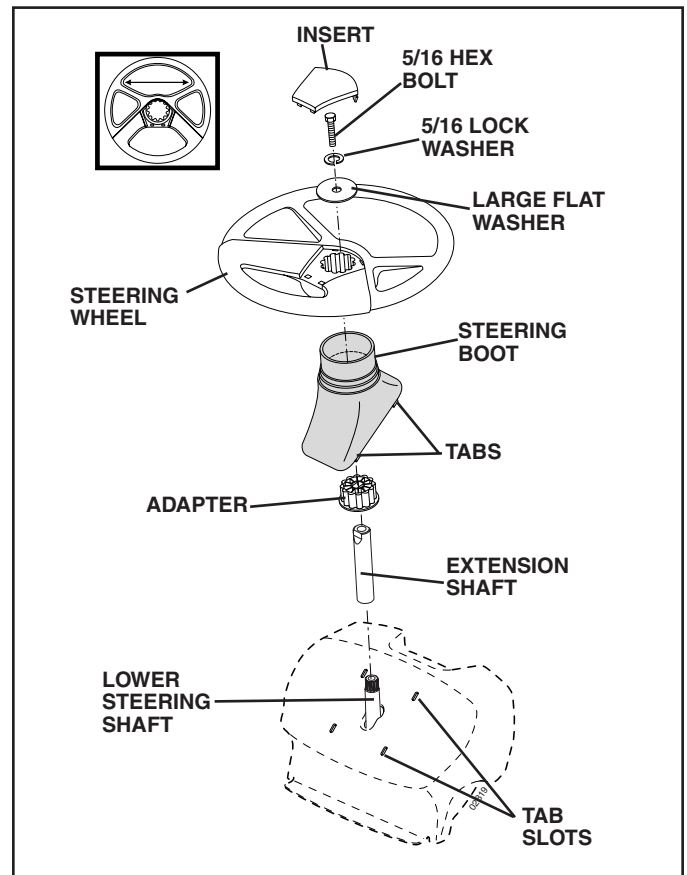

FIG. 1

INSTALL SEAT (See Fig. 2)

Adjust seat before tightening adjustment knob.

- Remove adjustment knob and flat washer securing seat to cardboard packing and set aside for assembly of seat to tractor.
- Pivot seat upward and remove from the cardboard packing. Remove the cardboard packing and discard.
- Place seat on seat pan so head of shoulder bolt is positioned over large slotted hole in pan.
- Push down on seat to engage shoulder bolt in slot and pull seat towards rear of tractor.
- Pivot seat and pan forward and assemble adjustment knob and flat washer loosely. Do not tighten.
- Lower seat into operating position and sit on seat.
- Slide seat until a comfortable position is reached which allows you to press clutch/brake pedal all the way down.
- Get off seat without moving its adjusted position.
- Raise seat and tighten adjustment knob securely.

ASSEMBLY

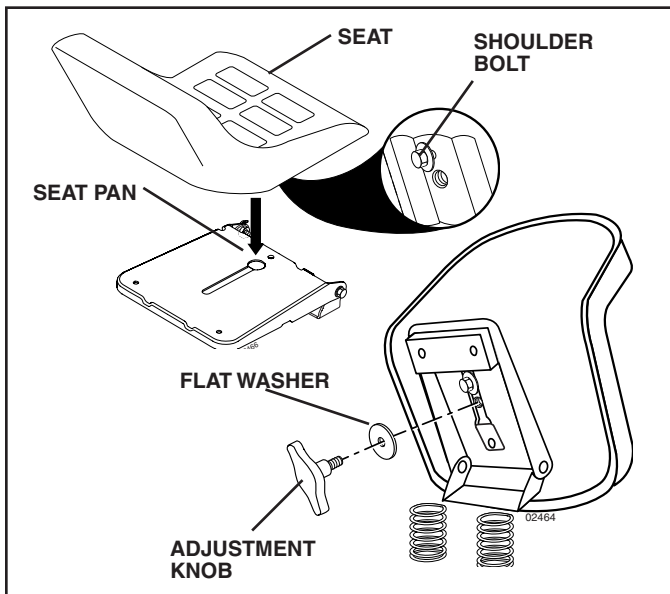

FIG. 2

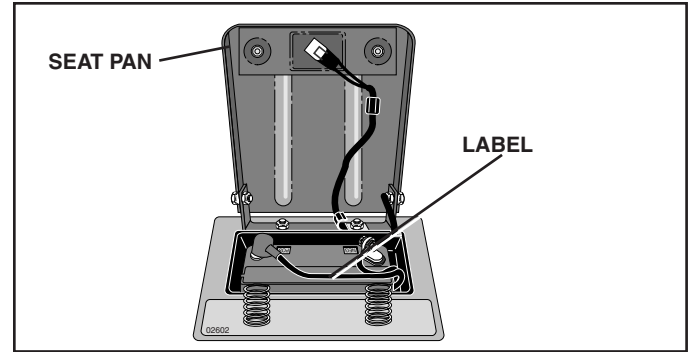

FIG. 4

NOTE: You may now roll or drive your tractor off the skid. Follow the appropriate instruction below to remove the tractor from the skid.

WARNING: Before starting, read, understand and follow all instructions in the Operation section of this manual. Be sure tractor is in a well-ventilated area. Be sure the area in front of tractor is clear of other people and objects.

TO ROLL TRACTOR OFF SKID (See Operation section for location and function of controls)

- Press lift lever plunger and raise attachment lift lever to its highest position.
- Release parking brake by depressing clutch/brake pedal.
- Place freewheel control in "transmission disengaged position" (See "TO TRANSPORT" in the Operation section of this manual).
- Roll tractor forward off skid.
- Remove banding holding the deflector shield up against tractor.

TO DRIVE TRACTOR OFF SKID (See Operation section for location and function of controls)

WARNING: Before starting, read, understand and follow all instructions in the Operation section of this manual. Be sure tractor is in a well-ventilated area. Be sure the area in front of tractor is clear of other people and objects.

- Be sure all the above assembly steps have been completed.
- Check engine oil level and fill fuel tank with gasoline.
- Place freewheel control in "transmission engaged" position (see "TO TRANSPORT" in Operation section of this manual).
- Sit on seat in operating position, depress clutch/brake pedal and set the parking brake.
- Place motion control lever in neutral (N) position.
- Press lift lever plunger and raise attachment lift lever to its highest position.

CONNECT BATTERY (See Figs. 3 and 4)



CAUTION: Do not short battery terminals by allowing a wrench or any other object to contact both terminals at the same time. Before connecting battery, remove metal bracelets, wristwatch bands, rings, etc.

Positive terminal must be connected first to prevent sparking from accidental grounding.

- Lift seat pan to raised position.
- Remove terminal protective caps and discard.
- If this battery is put into service after month and year indicated on label (label located between terminals) charge battery for minimum of one hour at 6-10 amps. (See "BATTERY" in the Maintenance section of this manual for charging instructions).
- First connect RED battery cable to positive (+) terminal with hex bolt and keps nut as shown. Tighten securely. Slide terminal cover over terminal.
- Connect BLACK grounding cable to negative (-) terminal with remaining hex bolt and keps nut. Tighten securely.

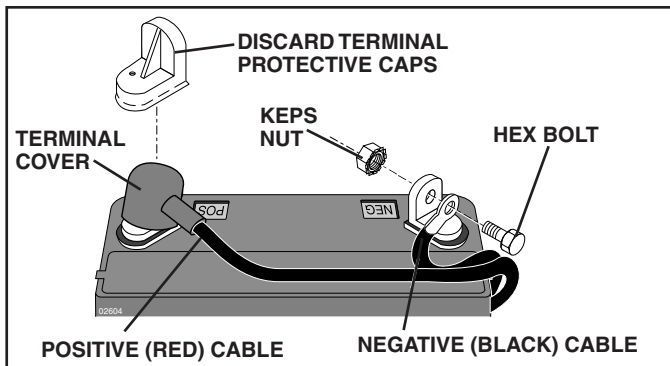

FIG. 3

ASSEMBLY

- Remove key from bag and start the engine (see "TO START ENGINE" in the Operation section of this manual). After engine has started, move throttle control to idle (slow) position.
- Release parking brake.
- Slowly move the motion control lever forward and slowly drive tractor off skid.
- Apply brake to stop tractor, set parking brake and place motion control lever in neutral position.
- Turn ignition key to "STOP" position.

Continue with the instructions that follow.

INSTALL MULCHER PLATE (See Fig. 5)

(If previously removed)

- Raise and hold deflector shield in upright position.
- Place front of mulcher plate over front of mower deck opening and slide into place, as shown.
- Hook front latch into hole on front of mower deck.
- Hook rear latch into hole on back of mower deck.



CAUTION: Do not remove deflector shield from mower.

TO CONVERT TO BAGGING OR DISCHARGING

Simply remove mulcher plate and store in a safe place. Your mower is now ready for discharging or installation of optional grass catcher accessory.

NOTE: It is not necessary to change blades. The mulcher blades are designed for discharging and bagging also.

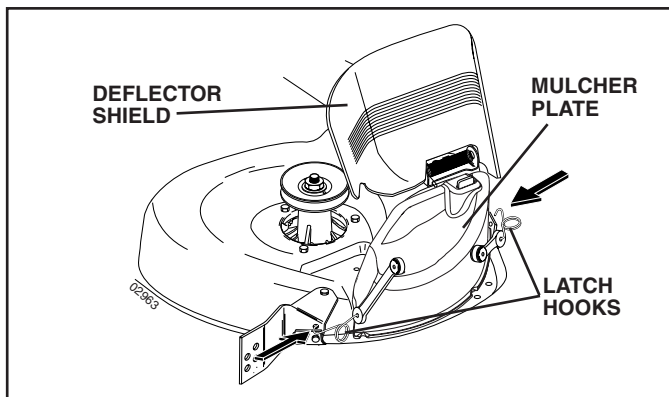

FIG. 5

CHECK TIRE PRESSURE

The tires on your tractor were overinflated at the factory for shipping purposes. Correct tire pressure is important for best cutting performance.

- Reduce tire pressure to PSI shown on tires.

CHECK DECK LEVELNESS

For best cutting results, mower housing should be properly leveled. See "TO LEVEL MOWER HOUSING" in the Service and Adjustments section of this manual.

CHECK FOR PROPER POSITION OF ALL BELTS

See the figures that are shown for replacing motion and mower blade drive belts in the Service and Adjustments section of this manual. Verify that the belts are routed correctly.

CHECK BRAKE SYSTEM

After you learn how to operate your tractor, check to see that the brake is operating properly. See "TO CHECK BRAKE" in the Service and Adjustments section of this manual.

✓ CHECKLIST

BEFORE YOU OPERATE YOUR NEW TRACTOR, WE WISH TO ASSURE THAT YOU RECEIVE THE BEST PERFORMANCE AND SATISFACTION FROM THIS QUALITY PRODUCT.

PLEASE REVIEW THE FOLLOWING CHECKLIST:

- ✓ All assembly instructions have been completed.
- ✓ No remaining loose parts in carton.
- ✓ Battery is properly prepared and charged.
- ✓ Seat is adjusted comfortably and tightened securely.
- ✓ All tires are properly inflated. (For shipping purposes, the tires were overinflated at the factory).
- ✓ Be sure mower deck is properly leveled side-to-side/front-to-rear for best cutting results. (Tires must be properly inflated for leveling).
- ✓ Check mower and drive belts. Be sure they are routed properly around pulleys and inside all belt keepers.
- ✓ Check wiring. See that all connections are still secure and wires are properly clamped.
- ✓ Before driving tractor, be sure freewheel control is in "transmission engaged" position (see "TO TRANSPORT" in the Operation section of this manual).

WHILE LEARNING HOW TO USE YOUR TRACTOR, PAY EXTRA ATTENTION TO THE FOLLOWING IMPORTANT ITEMS:

- ✓ Engine oil is at proper level.
- ✓ Fuel tank is filled with fresh, clean, regular unleaded gasoline.
- ✓ Become familiar with all controls, their location and function. Operate them before you start the engine.
- ✓ Be sure brake system is in safe operating condition.
- ✓ Be sure Operator Presence System and Reverse Operation System (ROS) are working properly (See the Operation and Maintenance sections in this manual).
- ✓ It is important to purge the transmission before operating your tractor for the first time. Follow proper starting and transmission purging instructions (See "TO START ENGINE" and "PURGE TRANSMISSION" in the Operation section of this manual).

OPERATION

These symbols may appear on your tractor or in literature supplied with the product. Learn and understand their meaning.

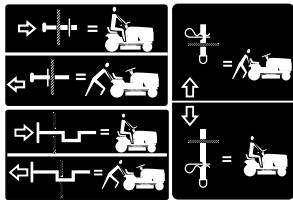

FREE WHEEL
(Automatic Models only)



Failure to follow instructions could result in serious injury or death. The safety alert symbol is used to identify safety information about hazards which can result in death, serious injury and/or property damage.



DANGER indicates a hazard which, if not avoided, will result in death or serious injury.



WARNING indicates a hazard which, if not avoided, could result in death or serious injury.



CAUTION indicates a hazard which, if not avoided, might result in minor or moderate injury.

CAUTION when used **without** the alert symbol, indicates a situation that **could result in damage to the tractor and/or engine.**



HOT SURFACES indicates a hazard which, if not avoided, could result in death, serious injury and/or property damage.



FIRE indicates a hazard which, if not avoided, could result in death, serious injury and/or property damage.

OPERATION

KNOW YOUR TRACTOR

READ THIS OWNER'S MANUAL AND SAFETY RULES BEFORE OPERATING YOUR TRACTOR

Compare the illustrations with your tractor to familiarize yourself with the locations of various controls and adjustments. Save this manual for future reference.

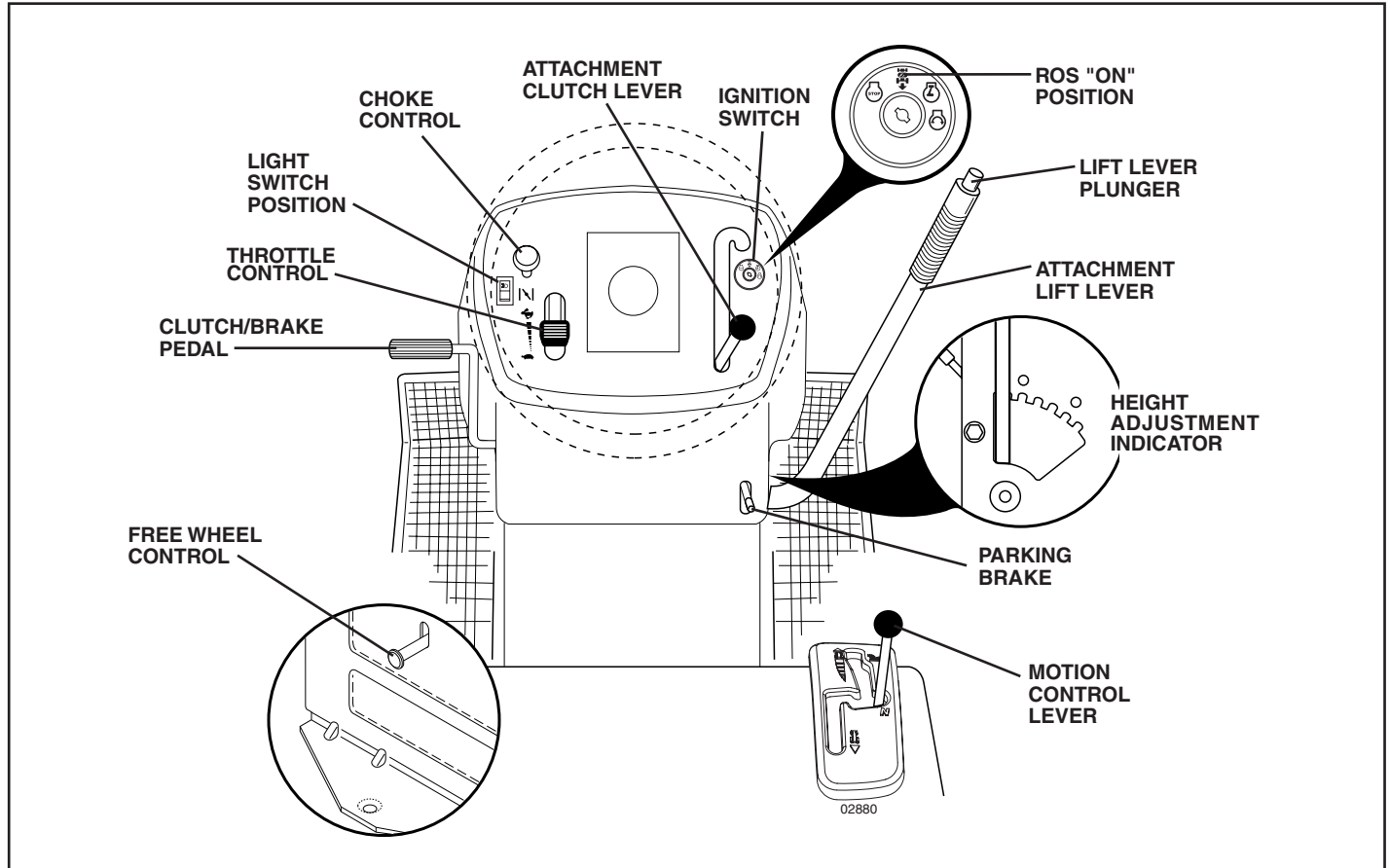

FIG. 6

Our tractors conform to the safety standards of the American National Standards Institute.

ATTACHMENT CLUTCH LEVER - Used to engage the mower blades, or other attachments mounted to your tractor.

ATTACHMENT LIFT LEVER - Used to raise, lower, and adjust the mower deck or other attachments mounted to your tractor.

CHOKE CONTROL - Used when starting a cold engine.

CLUTCH/BRAKE PEDAL - Used for declutching and braking the tractor and starting the engine.

FREEWHEEL CONTROL - Disengages transmission for pushing or slowly towing the tractor with the engine off.

LIFT LEVER PLUNGER - Used to release attachment lift lever when changing its position.

LIGHT SWITCH - Turns the headlights on and off.

IGNITION SWITCH - Used for starting and stopping the engine.

MOTION CONTROL LEVER - Selects the speed and direction of tractor.

PARKING BRAKE - Locks clutch/brake pedal into the brake position.

REVERSE OPERATION SYSTEM (ROS) "ON" POSITION - Allows operation of mower deck or other powered attachment while in reverse.

THROTTLE CONTROL - Used to control engine speed.

OPERATION



The operation of any tractor can result in foreign objects thrown into the eyes, which can result in severe eye damage. Always wear safety glasses or eye shields while operating your tractor or performing any adjustments or repairs. We recommend a wide vision safety mask over spectacles or standard safety glasses.

HOW TO USE YOUR TRACTOR

TO SET PARKING BRAKE (See Fig. 7)

Your tractor is equipped with an operator presence sensing switch. When engine is running, any attempt by the operator to leave the seat without first setting the parking brake will shut off the engine.

- Depress clutch/brake pedal into full "BRAKE" position and hold.
- Place parking brake lever in "ENGAGED" position and release pressure from clutch/brake pedal. Pedal should remain in "BRAKE" position. Make sure parking brake will hold tractor secure.

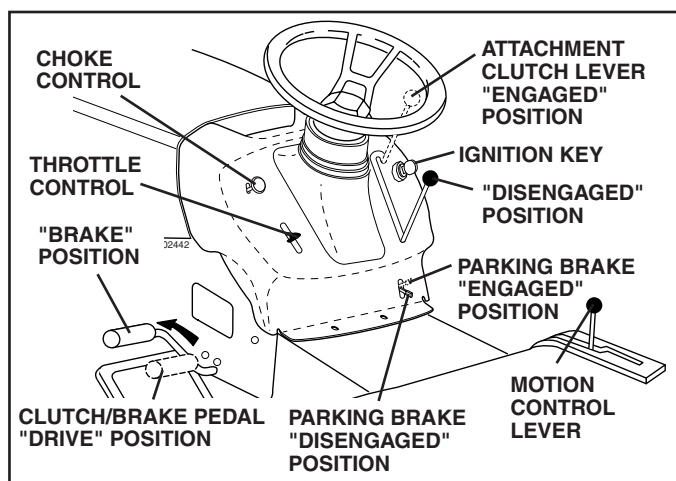

FIG. 7

STOPPING (See Fig. 7)

MOWER BLADES -

- To stop mower blades, move attachment clutch lever to "DISENGAGED" position.

GROUND DRIVE -

- To stop ground drive, depress clutch/brake pedal into full "BRAKE" position.
- Move motion control lever to neutral (N) position.

ENGINE -

- Move throttle control between half and full speed (fast) position.

NOTE: Failure to move throttle control between half and full speed (fast) position, before stopping may cause engine to "backfire".

- Turn ignition key to "STOP" position and remove key. Always remove key when leaving tractor to prevent unauthorized use.
- Never use choke to stop engine.

IMPORTANT: LEAVING THE IGNITION SWITCH IN ANY POSITION OTHER THAN "STOP" WILL CAUSE THE BATTERY TO BE DISCHARGED, (DEAD).

NOTE: Under certain conditions when tractor is standing idle with the engine running, hot engine exhaust gases may cause "browning" of grass. To eliminate this possibility, always stop engine when stopping tractor on grass areas.



CAUTION: Always stop tractor completely, as described above, before leaving the operator's position; to empty grass catcher, etc.

TO USE THROTTLE CONTROL (See Fig. 7)

Always operate engine at full speed (fast).

- Operating engine at less than full speed (fast) reduces the engine's operating efficiency.
- Full speed (fast) offers the best mower performance.

TO USE CHOKE CONTROL (See Fig. 7)

Use choke control whenever you are starting a cold engine. Do not use to start a warm engine.

- To engage choke control, pull knob out. Slowly push knob in to disengage.

TO MOVE FORWARD AND BACKWARD (See Fig. 7)

The direction and speed of movement is controlled by the motion control lever.

- Start tractor with motion control lever in neutral (N) position.
- Release parking brake.
- Slowly move motion control lever to desired position.

TO ADJUST MOWER CUTTING HEIGHT (See Fig. 7)

The position of the attachment lift lever determines the cutting height.

- Grasp lift lever.
- Press plunger with thumb and move lever to desired position.

The cutting height range is approximately 1-1/2 to 4". The heights are measured from the ground to the blade tip with the engine not running. These heights are approximate and may vary depending upon soil conditions, height of grass and types of grass being mowed.

- The average lawn should be cut to approximately 2-1/2 inches during the cool season and to over 3 inches during hot months. For healthier and better looking lawns, mow often and after moderate growth.
- For best cutting performance, grass over 6 inches in height should be mowed twice. Make the first cut relatively high; the second to desired height.

OPERATION

TO ADJUST GAUGE WHEELS (See Fig. 8)

Gauge wheels are properly adjusted when they are slightly off the ground when mower is at the desired cutting height in operating position. Gauge wheels then keep the deck in proper position to help prevent scalping in most terrain conditions.

NOTE: Adjust gauge wheels with tractor on a flat level surface.

- Adjust mower to desired cutting height (See "TO ADJUST MOWER CUTTING HEIGHT" in the Operation section of this manual).
- With mower in desired height of cut position, gauge wheels should be assembled so they are slightly off the ground. Install gauge wheel in appropriate hole with shoulder bolt, 3/8 washer, and 3/8-16 locknut and tighten securely.
- Repeat for opposite side installing gauge wheel in same adjustment hole.

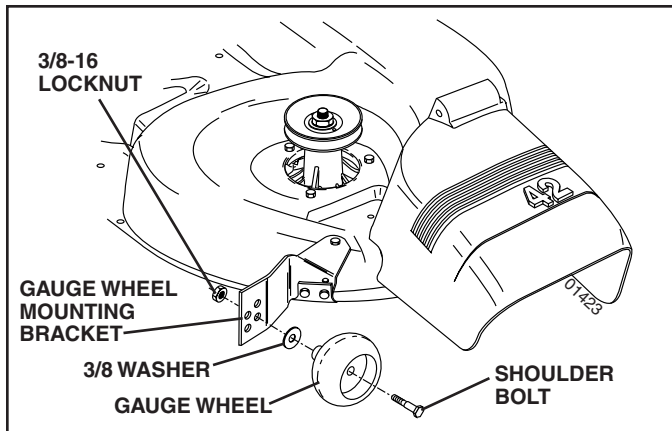

FIG. 8

TO OPERATE MOWER (See Fig. 9)

Your tractor is equipped with an operator presence sensing switch. Any attempt by the operator to leave the seat with the engine running and the attachment clutch engaged will shut off the engine. You must remain fully and centrally positioned in the seat to prevent the engine from hesitating or cutting off when operating your equipment on rough, rolling terrain or hills.

- Select desired height of cut.
- Start mower blades by engaging attachment clutch control.
- TO STOP MOWER BLADES - disengage attachment clutch control.

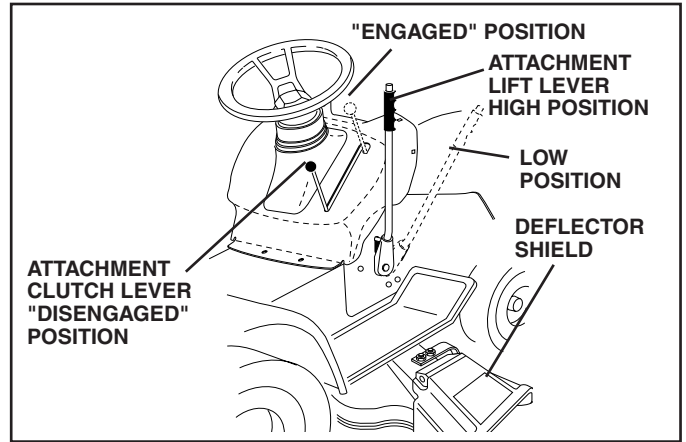
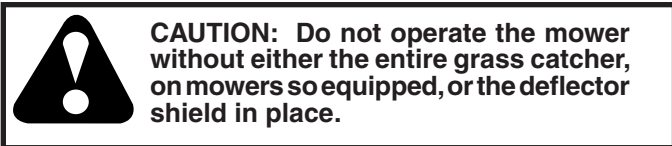

FIG. 9

REVERSE OPERATION SYSTEM (ROS)

Your tractor is equipped with a Reverse Operation System (ROS). Any attempt by the operator to travel in the reverse direction with the attachment clutch engaged will shut off the engine unless ignition key is placed in the ROS "ON" position.

⚠WARNING: Backing up with the attachment clutch engaged while mowing is strongly discouraged. Turning the ROS "ON", to allow reverse operation with the attachment clutch engaged, should only be done when the operator decides it is necessary to reposition the machine with the attachment engaged. **Do not mow in reverse unless absolutely necessary.**

USING THE REVERSE OPERATION SYSTEM -

- Move motion control lever to neutral (N) position.
- With engine running, turn ignition key counterclockwise to ROS "ON" position.
- Look down and behind before backing.
- Slowly move motion control lever to reverse (R) position to start movement.
- When use of the ROS is no longer needed, turn the ignition key clockwise to engine "ON" position.

ROS "ON" POSITION

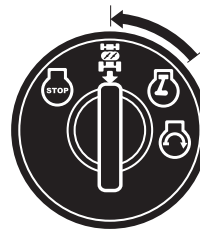

ENGINE "ON" POSITION (NORMAL OPERATING)



OPERATION

TO OPERATE ON HILLS



WARNING: Do not drive up or down hills with slopes greater than 15° and do not drive across any slope.

- Choose the slowest speed before starting up or down hills.
- Avoid stopping or changing speed on hills.
- If stopping is absolutely necessary, push clutch/brake pedal quickly to brake position and engage parking brake.
- Move motion control lever to neutral (N) position.

IMPORTANT: THE MOTION CONTROL LEVER DOES NOT RETURN TO NEUTRAL (N) POSITION WHEN THE CLUTCH/BRAKE PEDAL IS DEPRESSED.

- To restart movement, slowly release parking brake and clutch/brake pedal.
- Slowly move motion control lever to slowest setting.
- Make all turns slowly.

TO TRANSPORT (See Figs. 6 and 10)

When pushing or towing your tractor, be sure to disengage transmission by placing freewheel control in freewheeling position. Free wheel control is located at the rear drawbar of tractor.

- Raise attachment lift to highest position with attachment lift control.
- Pull freewheel control out and down into the slot and release so it is held in the disengaged position.
- Do not push or tow tractor at more than two (2) MPH.
- To reengage transmission, reverse above procedure.

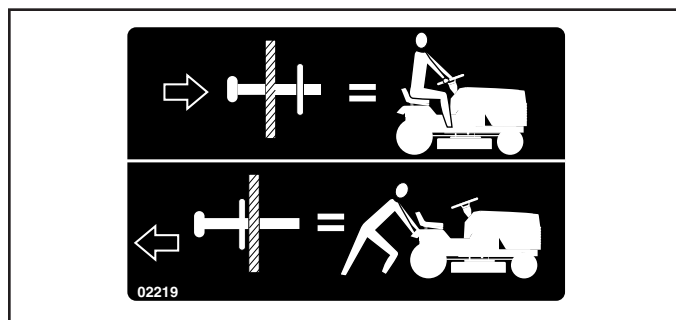

FIG. 10

NOTE: To protect hood from damage when transporting your tractor on a truck or a trailer, be sure hood is closed and secured to tractor. Use an appropriate means of tying hood to tractor (rope, cord, etc.).

TOWING CARTS AND OTHER ATTACHMENTS

Tow only the attachments that are recommended by and comply with specifications of the manufacturer of your tractor. Use common sense when towing. Too heavy of a load, while on a slope, is dangerous. Tires can lose traction with the ground and cause you to lose control of your tractor.

BEFORE STARTING THE ENGINE

CHECK ENGINE OIL LEVEL

The engine in your tractor has been shipped, from the factory, already filled with summer weight oil.

- Check engine oil with tractor on level ground.
- Remove oil fill cap/dipstick and wipe clean, reinsert the dipstick and screw cap tight, wait for a few seconds, remove and read oil level. If necessary, add oil until "FULL" mark on dipstick is reached. Do not overfill.
- For cold weather operation you should change oil for easier starting (See "OIL VISCOSITY CHART" in the Maintenance section of this manual).
- To change engine oil, see the Maintenance section in this manual.

ADD GASOLINE

- Fill fuel tank to bottom of filler neck. Do not overfill. Use fresh, clean, regular unleaded gasoline with a minimum of 87 octane. (Use of leaded gasoline will increase carbon and lead oxide deposits and reduce valve life). Do not mix oil with gasoline. Purchase fuel in quantities that can be used within 30 days to assure fuel freshness.



CAUTION: Wipe off any spilled oil or fuel. Do not store, spill or use gasoline near an open flame.

IMPORTANT: WHEN OPERATING IN TEMPERATURES BELOW 32°F (0°C), USE FRESH, CLEAN WINTER GRADE GASOLINE TO HELP INSURE GOOD COLD WEATHER STARTING.

CAUTION: Alcohol blended fuels (called gasohol or using ethanol or methanol) can attract moisture which leads to separation and formation of acids during storage. Acidic gas can damage the fuel system of an engine while in storage. To avoid engine problems, the fuel system should be emptied before storage of 30 days or longer. Drain the gas tank, start the engine and let it run until the fuel lines and carburetor are empty. Use fresh fuel next season. See Storage Instructions for additional information. Never use engine or carburetor cleaner products in the fuel tank or permanent damage may occur.

OPERATION

TO START ENGINE (See Fig. 7)

When starting the engine for the first time or if the engine has run out of fuel, it will take extra cranking time to move fuel from the tank to the engine.

- Be sure freewheel control is in the transmission engaged position.
- Sit on seat in operating position, depress clutch/brake pedal and set parking brake.
- Place motion control lever in neutral (N) position.
- Move attachment clutch to "DISENGAGED" position.
- Move throttle control to fast position
- Pull choke control out for a cold engine start attempt. For a warm engine start attempt the choke control may not be needed.

NOTE: Before starting, read the warm and cold starting procedures below.

- Insert key into ignition and turn key clockwise to "START" position and release key as soon as engine starts. Do not run starter continuously for more than fifteen seconds per minute. If the engine does not start after several attempts, push choke control in, wait a few minutes and try again. If engine still does not start, pull the choke control out and retry.

WARM WEATHER STARTING (50° F and above)

- When engine starts, slowly push choke control in until the engine begins to run smoothly. If the engine starts to run roughly, pull the choke control out slightly for a few seconds and then continue to push the control in slowly.
- The attachments and ground drive can now be used. If the engine does not accept the load, restart the engine and allow it to warm up for one minute using the choke as described above.

COLD WEATHER STARTING (50° F and below)

- When engine starts, slowly push choke control in until the engine begins to run smoothly. Continue to push the choke control in small steps allowing the engine to accept small changes in speed and load, until the choke control is fully in. If the engine starts to run roughly, pull the choke control out slightly for a few seconds and then continue to push the control in slowly. This may require an engine warm-up period from several seconds to several minutes, depending on the temperature.

AUTOMATIC TRANSMISSION WARM UP

- Before driving the unit in cold weather, the transmission should be warmed up as follows:
 - Be sure the tractor is on level ground.
 - Place the motion control lever in neutral. Release the parking brake and let the clutch/brake slowly return to operating position.
 - Allow one minute for transmission to warm up. This can be done during the engine warm up period.
- The attachments can be used during the engine warm-up period after the transmission has been warmed up and may require the choke control be pulled out slightly.

NOTE: If at a high altitude (above 3000 feet) or in cold temperatures (below 32 F) the carburetor fuel mixture may need to be adjusted for best engine performance. See "TO ADJUST CARBURETOR" in the Service and Adjustments section of this manual.

PURGE TRANSMISSION

To ensure proper operation and performance, it is recommended that the transmission be purged before operating tractor for the first time. This procedure will remove any trapped air inside the transmission which may have developed during shipping of your tractor.

IMPORTANT: SHOULD YOUR TRANSMISSION REQUIRE REMOVAL FOR SERVICE OR REPLACEMENT, IT SHOULD BE PURGED AFTER REINSTALLATION BEFORE OPERATING THE TRACTOR.

- Place tractor safely in an area that is flat for approximately 80 feet in front of the tractor and set the parking brake.
- Sitting in the tractor seat, start engine. After the engine is running, move throttle control to slow position. With motion control lever in neutral (N) position, slowly disengage clutch/brake pedal.
- Slowly move motion control lever to full forward position and hold for five (5) seconds, or approximately 40 feet. Slowly move lever to full reverse position and hold for five (5) seconds, or approximately 20 feet. After the tractor moves approximately 20 feet in reverse return the motion control lever to the neutral (N) position.

Your transmission is now purged and now ready for normal operation.

OPERATION

MOWING TIPS

- Mower should be properly leveled for best mowing performance. See "TO LEVEL MOWER HOUSING" in the Service and Adjustments section of this manual.
- The left hand side of mower should be used for trimming.
- Drive so that clippings are discharged onto the area that has been cut. Have the cut area to the right of the machine. This will result in a more even distribution of clippings and more uniform cutting.
- When mowing large areas, start by turning to the right so that clippings will discharge away from shrubs, fences, driveways, etc. After one or two rounds, mow in the opposite direction making left hand turns until finished (See Fig. 11).

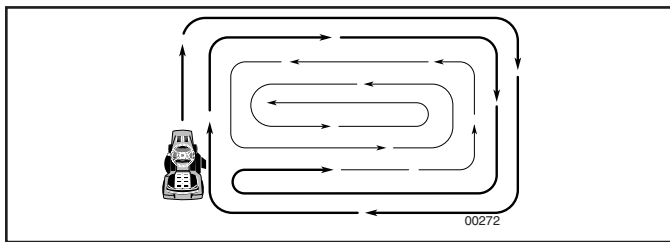

FIG. 11

- If grass is extremely tall, it should be mowed twice to reduce load and possible fire hazard from dried clippings. Make first cut relatively high; the second to the desired height.
- Do not mow grass when it is wet. Wet grass will plug mower and leave undesirable clumps. Allow grass to dry before mowing.
- **Always operate engine at full throttle when mowing** to assure better mowing performance and proper discharge of material. Regulate ground speed by selecting a low enough gear to give the mower cutting performance as well as the quality of cut desired.
- When operating attachments, select a ground speed that will suit the terrain and give best performance of the attachment being used.

MULCHING MOWING TIPS

IMPORTANT: FOR BEST PERFORMANCE, KEEP MOWER HOUSING FREE OF BUILT-UP GRASS AND TRASH. CLEAN AFTER EACH USE.

- The special mulching blade will recut the grass clippings many times and reduce them in size so that as they fall onto the lawn they will disperse into the grass and not be noticed. Also, the mulched grass will biodegrade quickly to provide nutrients for the lawn. Always mulch with your highest engine (blade) speed as this will provide the best recutting action of the blades.
- Avoid cutting your lawn when it is wet. Wet grass tends to form clumps and interferes with the mulching action. The best time to mow your lawn is the early afternoon. At this time the grass has dried, yet the newly cut area will not be exposed to direct sunlight.
- For best results, adjust the mower cutting height so that the mower cuts off only the top one-third of the grass blades (See Fig. 12). For extremely heavy mulching, reduce your width of cut on each pass and mow slowly.

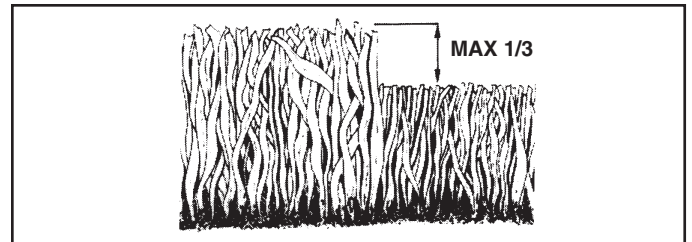

FIG. 12

- Certain types of grass and grass conditions may require that an area be mulched a second time to completely hide the clippings. When doing a second cut, mow across (perpendicular) to the first cut path.
- Change your cutting pattern from week to week. Mow north to south one week then change to east to west the next week. This will help prevent matting and graining of the lawn.

MAINTENANCE

| MAINTENANCE SCHEDULE | | BEFORE EACH USE | EVERY 8 HOURS | EVERY 25 HOURS | EVERY 50 HOURS | EVERY 100 HOURS | EVERY SEASON | BEFORE STORAGE |
|--|--|------------------------|---------------|------------------|------------------|------------------|--------------|----------------|
| T R A C T O R | Check Brake Operation | ✓ | ✓ | | | | | |
| | Check Tire Pressure | ✓ | ✓ | | | | | |
| | Check Operator Presence & ROS Systems | ✓ | | | | | | |
| | Check for Loose Fasteners | ✓ | | | | ✓ | | ✓ |
| | Check/Replace Mower Blades | | | ✓ ³ | | | | |
| | Lubrication Chart | | | ✓ | | | | ✓ |
| | Check Battery Level | | | ✓ ⁴ | | | | |
| | Clean Battery and Terminals | | | ✓ | | | | ✓ |
| | Check Transaxle Cooling | | | ✓ | | | | |
| | Check Mower Levelness | | | | ✓ | | | |
| | Check V-Belts | | | | | ✓ | | |
| | E N G I N E | Check Engine Oil Level | ✓ | ✓ | | | | |
| Change Engine Oil (with oil filter) | | | | | ✓ ^{1,2} | | | ✓ |
| Change Engine Oil (without oil filter) | | | | ✓ ^{1,2} | | | | ✓ |
| Clean Air Filter | | | | ✓ ² | | | | |
| Clean Air Screen | | | | ✓ ² | | | | |
| Inspect Muffler/Spark Arrester | | | | | ✓ | | | |
| Replace Oil Filter (If equipped) | | | | | | ✓ ^{1,2} | | |
| Clean Engine Cooling Fins | | | | | | ✓ ² | | |
| Replace Spark Plug | | | | | | ✓ | ✓ | |
| Replace Air Filter Paper Cartridge | | | | | | ✓ ² | | |
| Replace Fuel Filter | | | | | | | ✓ | |

maint_sch-tractors.ROS.e

- 1 - Change more often when operating under a heavy load or in high ambient temperatures.
 2 - Service more often when operating in dirty or dusty conditions.

- 3 - Replace blades more often when mowing in sandy soil.
 4 - Not required if equipped with maintenance-free battery.

GENERAL RECOMMENDATIONS

The warranty on this tractor does not cover items that have been subjected to operator abuse or negligence. To receive full value from the warranty, operator must maintain tractor as instructed in this manual.

Some adjustments will need to be made periodically to properly maintain your tractor.

At least once a season, check to see if you should make any of the adjustments described in the Service and Adjustments section of this manual.

- At least once a year you should replace the spark plug, clean or replace air filter, and check blades and belts for wear. A new spark plug and clean air filter assure proper air-fuel mixture and help your engine run better and last longer.

BEFORE EACH USE

- Check engine oil level.
- Check brake operation.
- Check tire pressure.
- Check operator presence and ROS systems for proper operation.
- Check for loose fasteners.

LUBRICATION CHART

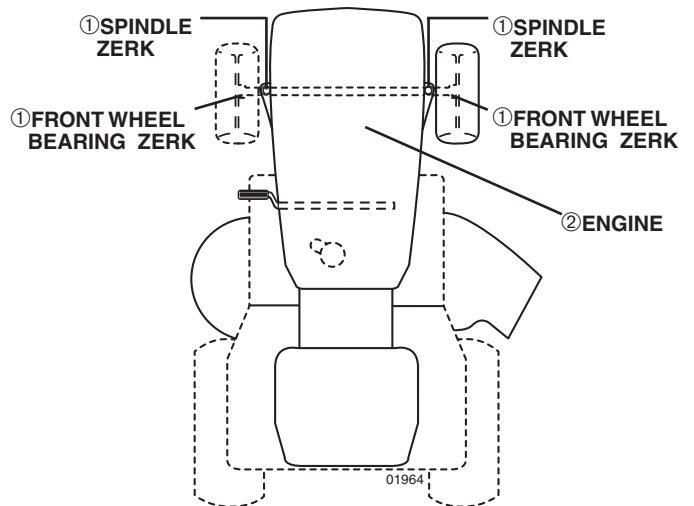

- ① GENERAL PURPOSE GREASE
- ② REFER TO MAINTENANCE "ENGINE" SECTION

IMPORTANT: DO NOT OIL OR GREASE THE PIVOT POINTS WHICH HAVE SPECIAL NYLON BEARINGS. VISCOUS LUBRICANTS WILL ATTRACT DUST AND DIRT THAT WILL SHORTEN THE LIFE OF THE SELF-LUBRICATING BEARINGS. IF YOU FEEL THEY MUST BE LUBRICATED, USE ONLY A DRY, POWDERED GRAPHITE TYPE LUBRICANT SPARINGLY.

MAINTENANCE

TRACTOR

Always observe safety rules when performing any maintenance.

BRAKE OPERATION

If tractor requires more than five (5) feet to stop at highest speed in highest gear on a level, dry concrete or paved surface, then brake must be checked and adjusted. (See "TO ADJUST BRAKE" in the Service and Adjustments section of this manual).

TIRES

- Maintain proper air pressure in all tires (See "PRODUCT SPECIFICATIONS" section of this manual).
- Keep tires free of gasoline, oil, or insect control chemicals which can harm rubber.
- Avoid stumps, stones, deep ruts, sharp objects and other hazards that may cause tire damage.

NOTE: To seal tire punctures and prevent flat tires due to slow leaks, tire sealant may be purchased from your local parts dealer. Tire sealant also prevents tire dry rot and corrosion.

OPERATOR PRESENCE SYSTEM AND REVERSE OPERATION SYSTEM (ROS)

Be sure operator presence and reverse operation systems are working properly. If your tractor does not function as described, repair the problem immediately.

- The engine should not start unless the brake pedal is fully depressed, and the attachment clutch control is in the disengaged position.

CHECK OPERATOR PRESENCE SYSTEM

- When the engine is running, any attempt by the operator to leave the seat without first setting the parking brake should shut off the engine.
- When the engine is running and the attachment clutch is engaged, any attempt by the operator to leave the seat should shut off the engine.
- The attachment clutch should never operate unless the operator is in the seat.

CHECK REVERSE OPERATION (ROS) SYSTEM

- When the engine is running with the ignition switch in the engine "ON" position and the attachment clutch engaged, any attempt by the operator to shift into reverse should shut off the engine.
- When the engine is running with the ignition switch in the ROS "ON" position and the attachment clutch engaged, any attempt by the operator to shift into reverse should NOT shut off the engine.

ROS "ON" POSITION

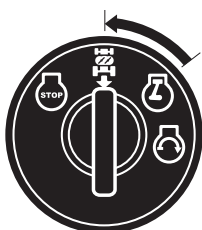

ENGINE "ON" POSITION (NORMAL OPERATING)



BLADE CARE

For best results mower blades must be kept sharp. Replace bent or damaged blades.



CAUTION: Use only a replacement blade approved by the manufacturer of your tractor. Using a blade not approved by the manufacturer of your tractor is hazardous, could damage your tractor and void your warranty.

BLADE REMOVAL (See Fig. 13)

- Raise mower to highest position to allow access to blades.
- Remove blade bolt, lock washer and flat washer securing blade.
- Install new or resharpened blade with trailing edge up towards deck as shown.

IMPORTANT: TO ENSURE PROPER ASSEMBLY, CENTER HOLE IN BLADE MUST ALIGN WITH STAR ON MANDREL ASSEMBLY.

- Reassemble blade bolt, lock washer and flat washer in exact order as shown.
- Tighten blade bolt securely (27-35 Ft. Lbs. torque).

IMPORTANT: BLADE BOLT IS HEAT TREATED. IF BOLT NEEDS REPLACING, REPLACE ONLY WITH APPROVE BOLT SHOWN IN THE REPAIR PARTS.

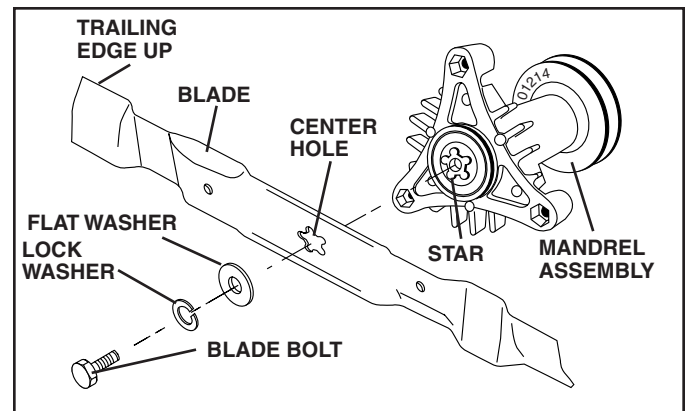

FIG. 13

TO SHARPEN BLADE (See Fig. 14)

NOTE: We do not recommend sharpening blade - but if you do, be sure the blade is balanced.

Care should be taken to keep the blade balanced. An unbalanced blade will cause excessive vibration and eventual damage to mower and engine.

- The blade can be sharpened with a file or on a grinding wheel. Do not attempt to sharpen while on the mower.
- To check blade balance, you will need a 5/8" diameter steel bolt, pin, or a cone balancer. (When using a cone balancer, follow the instructions supplied with balancer).

NOTE: Do not use a nail for balancing blade. The lobes of the center hole may appear to be centered, but are not.

MAINTENANCE

- Slide blade on to an unthreaded portion of the steel bolt or pin and hold the bolt or pin parallel with the ground. If blade is balanced, it should remain in a horizontal position. If either end of the blade moves downward, sharpen the heavy end until the blade is balanced.

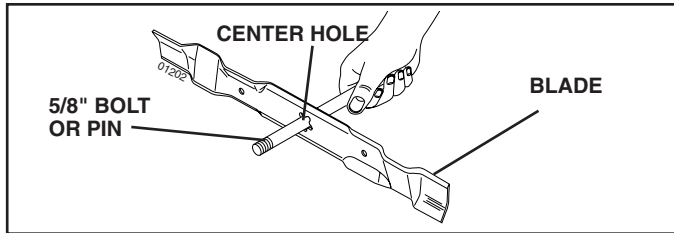

FIG. 14

BATTERY

Your tractor has a battery charging system which is sufficient for normal use. However, periodic charging of the battery with an automotive charger will extend its life.

- Keep battery and terminals clean.
- Keep battery bolts tight.
- Keep small vent holes open.
- Recharge at 6-10 amperes for 1 hour.

NOTE: The original equipment battery on your tractor is maintenance free. Do not attempt to open or remove caps or covers. Adding or checking level of electrolyte is not necessary.

TO CLEAN BATTERY AND TERMINALS

Corrosion and dirt on the battery and terminals can cause the battery to "leak" power.

- Disconnect BLACK battery cable first then RED battery cable and remove battery from tractor.
- Rinse the battery with plain water and dry.
- Clean terminals and battery cable ends with wire brush until bright.
- Coat terminals with grease or petroleum jelly.
- Reinstall battery (See "CONNECT BATTERY" in the Assembly section of this manual).

V-BELTS

Check V-belts for deterioration and wear after 100 hours of operation and replace if necessary. The belts are not adjustable. Replace belts if they begin to slip from wear.

TRANSAXLE COOLING

The transmission fan and cooling fins should be kept clean to assure proper cooling.

Do not attempt to clean fan or transmission while engine is running or while the transmission is hot. To prevent possible damage to seals, do not use high pressure water or steam to clean transaxle.

- Inspect cooling fan to be sure fan blades are intact and clean.
- Inspect cooling fins for dirt, grass clippings and other materials. To prevent damage to seals, do not use compressed air or high pressure sprayer to clean cooling fins.

TRANSAXLE PUMP FLUID

The transaxle was sealed at the factory and fluid maintenance is not required for the life of the transaxle. Should the transaxle ever leak or require servicing, contact your nearest authorized service center/department.

ENGINE

LUBRICATION

Only use high quality detergent oil rated with API service classification SG-SL. Select the oil's SAE viscosity grade according to your expected operating temperature. When operating in temperatures below 0° F (-18° C) synthetic oil must be used.

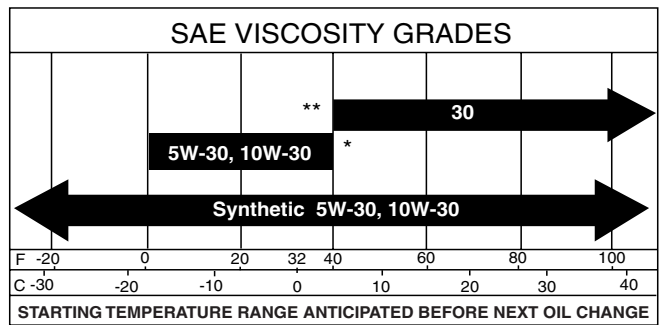

FIG. 15

*** CAUTION:** Air cooled engines run hotter than automotive engines. The use of non-synthetic multi-viscosity oils (5W30, 10W30 etc.) in temperatures above 40° F (4° C) will result in higher than normal oil consumption. When using a multi-viscosity oil, check oil level more frequently.

**** CAUTION:** SAE 30 oil, if used below 40° F (4° C), will result in hard starting and possible engine bore damage due to inadequate lubrication.



NOTE: Synthetic oil meeting ILSAC GF-2, API certification mark and API service symbol (shown at left) with "SJ/CF ENERGY CONSERVING" or higher, is an acceptable oil at all temperatures. **Use of synthetic oil does not alter required oil change intervals.**

Change the oil after every 50 hours of operation or at least once a year if the tractor is not used for 50 hours in one year.

Check the crankcase oil level before starting the engine and after each eight (8) hours of operation. Tighten oil fill cap/dipstick securely each time you check the oil level.

TO CHANGE ENGINE OIL (See Figs. 15 and 16)

Determine temperature range expected before oil change. All oil must meet API service classification SG-SL.

- Be sure tractor is on level surface.
- Oil will drain more freely when warm.
- Catch oil in a suitable container.
- Remove oil fill cap/dipstick. Be careful not to allow dirt to enter the engine when changing oil.
- Remove yellow cap from end of drain valve and install the drain tube onto the fitting.

MAINTENANCE

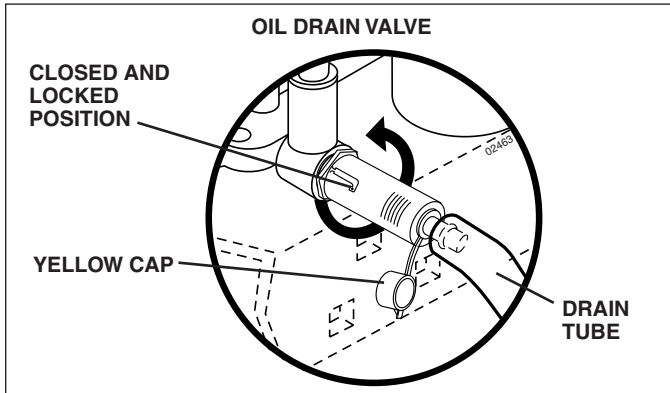

FIG. 16

- Unlock drain valve by pushing inward and turning counterclockwise.
- To open, pull out on the drain valve.
- After oil has drained completely, close and lock the drain valve by pushing inward and turning clockwise until the pin is in the locked position as shown.
- Remove the drain tube and replace the cap onto to the bottom fitting of the drain valve.
- Refill engine with oil through oil fill dipstick tube. Pour slowly. Do not overfill. For approximate capacity see "PRODUCT SPECIFICATIONS" section of this manual.
- Use gauge on oil fill cap/dipstick for checking level. Be sure dipstick cap is tightened securely for accurate reading. Keep oil at "FULL" line on dipstick. Tighten cap onto the tube securely when finished.

CLEAN AIR SCREEN

Air screen must be kept free of dirt and chaff to prevent engine damage from overheating. Clean with a wire brush or compressed air to remove dirt and stubborn dried gum fibers.

ENGINE OIL FILTER

Replace the engine oil filter every season or every other oil change if the tractor is used more than 100 hours in one year.

AIR FILTER (See Fig. 17)

Your engine will not run properly using a dirty air filter. Clean the foam pre-cleaner after every 25 hours of operation or every season. Service paper cartridge every 100 hours of operation or every season, whichever occurs first.

Service air cleaner more often under dusty conditions.

- Remove cover.

TO SERVICE PRE-CLEANER

- Wash it in liquid detergent and water.
- Squeeze it dry in a clean cloth.
- Saturate it in engine oil. Wrap it in clean, absorbent cloth and squeeze to remove excess oil.
- If very dirty or damaged, replace pre-cleaner.

TO SERVICE CARTRIDGE

- Clean cartridge by tapping gently on flat surface. If very dirty or damaged, replace cartridge.
- Reinstall pre-cleaner cartridge, cover and secure.

IMPORTANT: PETROLEUM SOLVENTS, SUCH AS KEROSENE, ARE NOT TO BE USED TO CLEAN THE CARTRIDGE. THEY MAY CAUSE DETERIORATION OF THE CARTRIDGE. DO NOT OIL CARTRIDGE. DO NOT USE PRESSURIZED AIR TO CLEAN OR DRY CARTRIDGE.

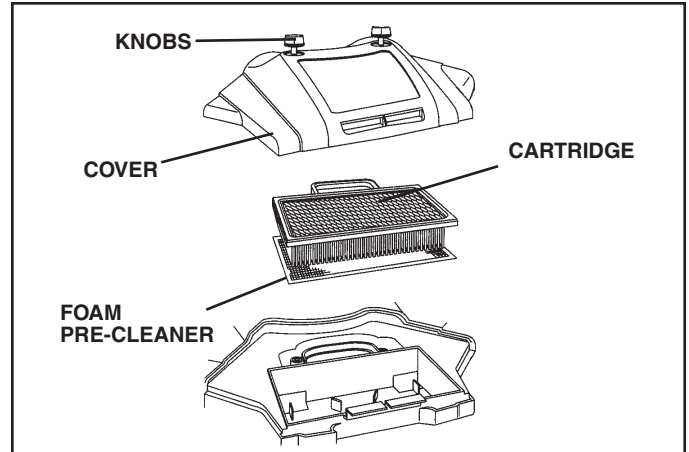

FIG. 17

CLEAN AIR INTAKE/COOLING AREAS

To insure proper cooling, make sure the grass screen, cooling fins, and other external surfaces of the engine are kept clean at all times.

Every 100 hours of operation (more often under extremely dusty, dirty conditions), remove the blower housing and other cooling shrouds. Clean the cooling fins and external surfaces as necessary. Make sure the cooling shrouds are reinstalled.

NOTE: Operating the engine with a blocked grass screen, dirty or plugged cooling fins, and/or cooling shrouds removed will cause engine damage due to overheating.

MUFFLER

Inspect and replace corroded muffler and spark arrester (if equipped) as it could create a fire hazard and/or damage.

SPARK PLUGS

Replace spark plugs at the beginning of each mowing season or after every 100 hours of operation, whichever occurs first. Spark plug type and gap setting are shown in "PRODUCT SPECIFICATIONS" section of this manual.

IN-LINE FUEL FILTER (See Fig. 18)

The fuel filter should be replaced once each season. If fuel filter becomes clogged, obstructing fuel flow to carburetor, replacement is required.

- With engine cool, remove filter and plug fuel line sections.
- Place new fuel filter in position in fuel line with arrow pointing towards carburetor.
- Be sure there are no fuel line leaks and clamps are properly positioned.
- Immediately wipe up any spilled gasoline.

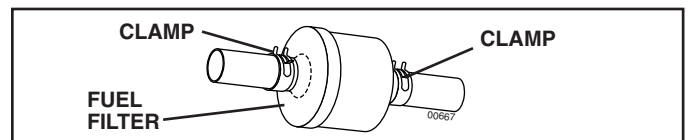

FIG. 18

MAINTENANCE

CLEANING

- Clean engine, battery, seat, finish, etc. of all foreign matter.
- Keep finished surfaces and wheels free of all gasoline, oil, etc.
- Protect painted surfaces with automotive type wax.

We do not recommend using a garden hose or pressure washer to clean your tractor unless the engine and transmission are covered to keep water out. Water in engine or transmission will shorten the useful life of your tractor. Use compressed air or a leaf blower to remove grass, leaves and trash from tractor and mower.

SERVICE AND ADJUSTMENTS



WARNING: TO AVOID SERIOUS INJURY, BEFORE PERFORMING ANY SERVICE OR ADJUSTMENTS:

- Depress clutch/brake pedal fully and set parking brake.
- Place motion control lever in neutral (N) position.
- Place attachment clutch in “DISENGAGED” position.
- Turn ignition key to “STOP” and remove key.
- Make sure the blades and all moving parts have completely stopped.
- Disconnect spark plug wire from spark plug and place wire where it cannot come in contact with plug.

TRACTOR

TO REMOVE MOWER (See Fig. 19)

Mower will be easier to remove from the right side of tractor.

- Place attachment clutch in “DISENGAGED” position.
- Move attachment lift lever forward to lower mower to its lowest position.
- Roll belt off engine pulley.

- Remove small retainer spring, and remove clutch spring off pulley bolt.
- Remove large retainer spring, slide collar off and push housing guide out of bracket.
- Disconnect anti-swaybar from chassis bracket by removing retainer spring.
- Disconnect suspension arms from rear deck brackets by removing retainer springs.
- Disconnect front links from deck by removing retainer springs.

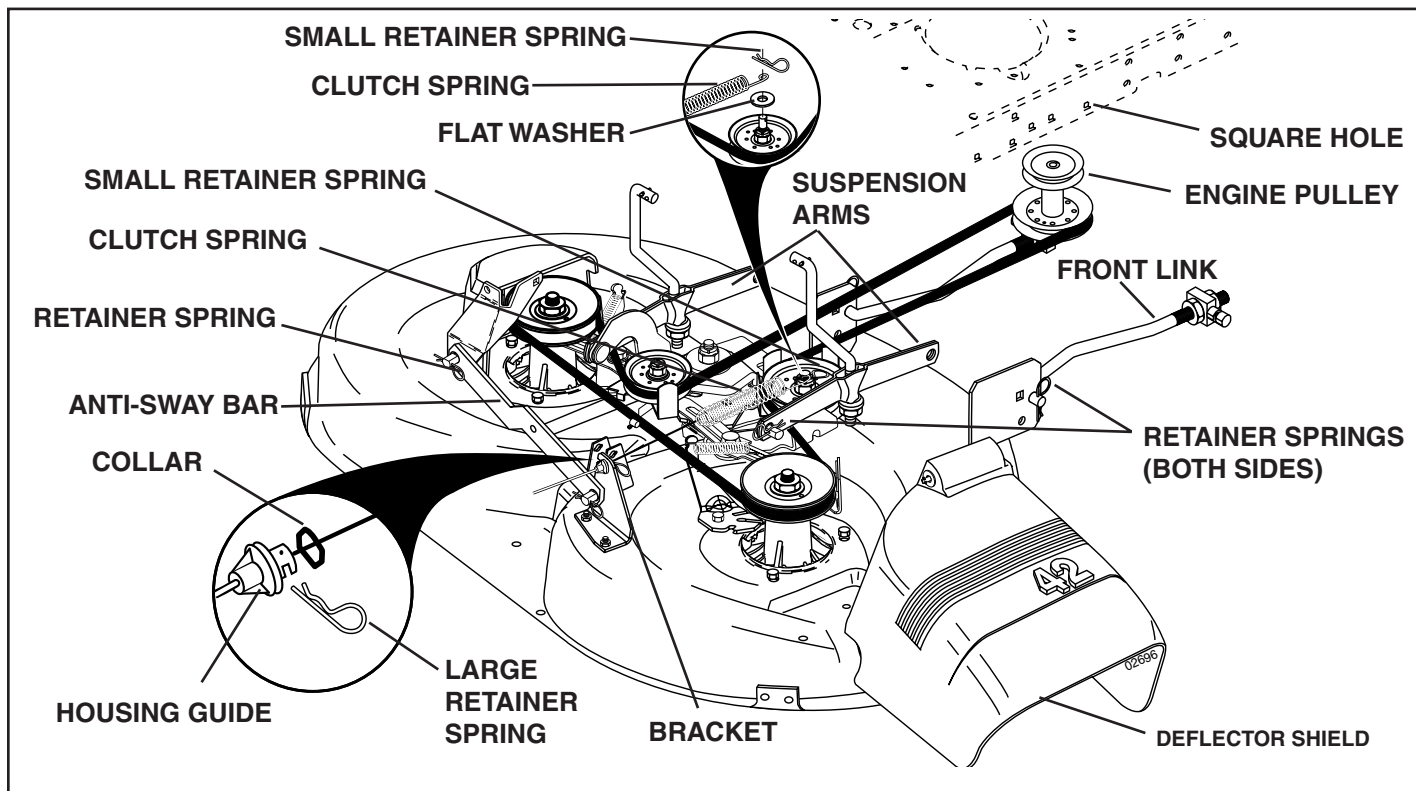

FIG. 19

SERVICE AND ADJUSTMENTS

- Raise lift lever to raise suspension arms. Slide mower out from under tractor.

IMPORTANT: IF AN ATTACHMENT OTHER THAN THE MOWER DECK IS TO BE MOUNTED ON THE TRACTOR, REMOVE THE FRONT LINKS AND HOOK THE CLUTCH SPRING INTO SQUARE HOLE IN FRAME.

TO INSTALL MOWER (See Fig. 19)

- Raise attachment lift lever to its highest position.
- Slide mower under tractor with deflector shield to right side of tractor.
- Lower lift lever to its lowest position.
- Connect front links to mower deck and secure with retainer springs..
- Connect suspension arms to rear deck brackets and secure with retainer springs.
- Connect anti-swaybar to chassis bracket and secure with retainer spring.
- Push clutch cable housing guide into bracket, slide collar onto guide and secure with large retainer spring.
- Place flat washer and clutch spring on idler pulley bolt and secure with small retainer spring.
- Install belt onto engine pulley.

TO LEVEL MOWER HOUSING

Adjust the mower while tractor is parked on level ground or driveway. Make sure tires are properly inflated (See "PRODUCT SPECIFICATIONS" section of this manual). If tires are over or underinflated, you will not properly adjust your mower.

SIDE-TO-SIDE ADJUSTMENT (See Figs. 20 and 21)

- Raise mower to its highest position.
- At the midpoint of both sides of mower, measure height from bottom edge of mower to ground. Distance "A" on both sides of mower should be the same or within 1/4" of each other.
- If adjustment is necessary, make adjustment on one side of mower only.
- To raise one side of mower, tighten lift link adjustment nut on that side.
- To lower one side of mower, loosen lift link adjustment nut on that side.

NOTE: Each full turn of adjustment nut will change mower height about 1/8".

- Recheck measurements after adjusting.

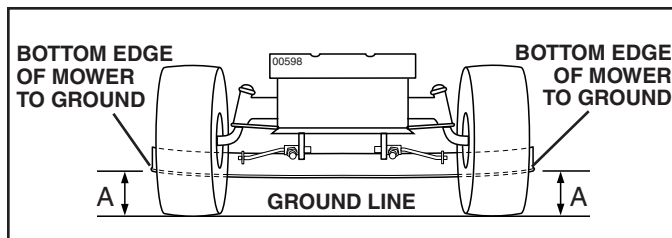

FIG. 20

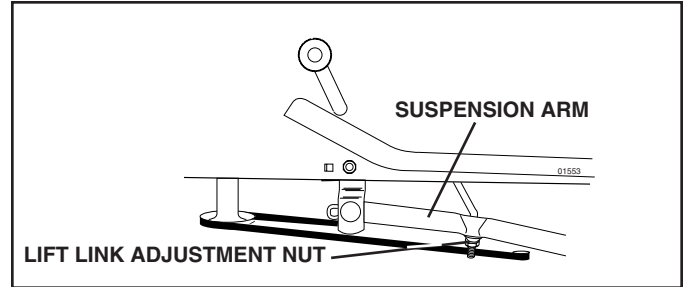

FIG. 21

FRONT-TO-BACK ADJUSTMENT (See Figs. 22 and 23)

IMPORTANT: DECK MUST BE LEVEL SIDE-TO-SIDE. IF THE FOLLOWING FRONT-TO-BACK ADJUSTMENT IS NECESSARY, BE SURE TO ADJUST BOTH FRONT LINKS EQUALLY SO MOWER WILL STAY LEVEL SIDE-TO-SIDE.

To obtain the best cutting results, the mower housing should be adjusted so that the front is approximately 1/8" to 1/2" lower than the rear when the mower is in its highest position.

Check adjustment on right side of tractor. Measure distance "D" directly in front and behind the mandrel at bottom edge of mower housing as shown.

- Before making any necessary adjustments, check that both front links are equal in length.
- If links are not equal in length, adjust one link to same length as other link.
- To lower front of mower loosen nut "E" on both front links an equal number of turns.
- When distance "D" is 1/8" to 1/2" lower at front than rear, tighten nuts "F" against trunnion on both front links.
- To raise front of mower, loosen nut "F" from trunnion on both front links. Tighten nut "E" on both front links an equal number of turns. The two front links must remain equal in length.
- When distance "D" is 1/8" to 1/2" lower at front than rear, tighten nut "F" against trunnion on both front links.
- Recheck side-to-side adjustment.

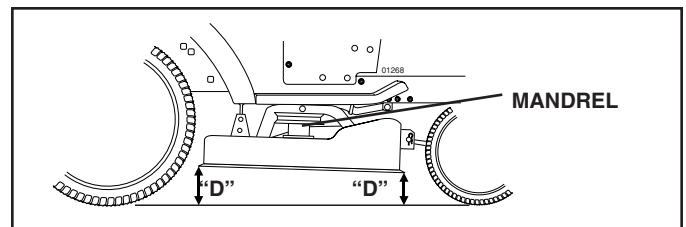

FIG. 22

SERVICE AND ADJUSTMENTS

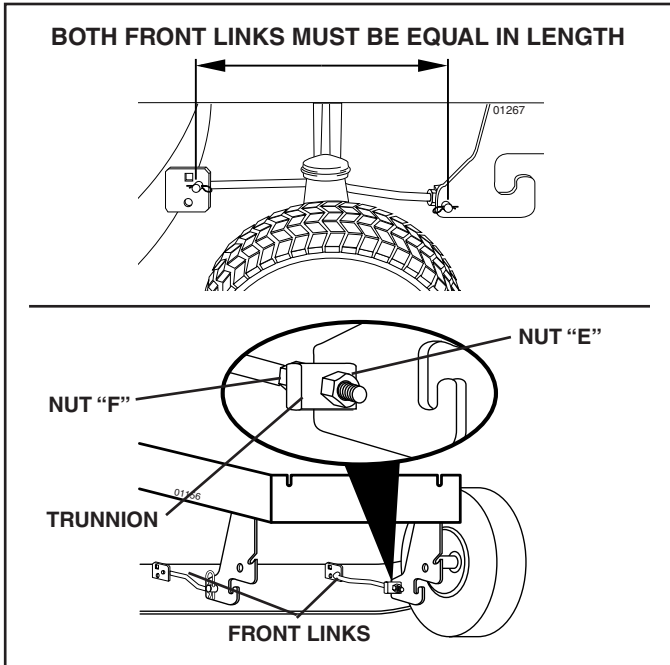

FIG. 23

TO REPLACE MOWER BLADE DRIVE BELT (See Fig. 24)

The mower blade drive belt may be replaced without tools. Park the tractor on level surface. Engage parking brake.

BELT REMOVAL -

- Remove mower from tractor (See "TO REMOVE MOWER" in this section of this manual).
- Work belt off both mandrel pulleys and idler pulleys.
- Pull belt away from mower.

BELT INSTALLATION -

- Install new belt in reverse order of removal.
- Make sure belt is in all pulley grooves and inside all belt guides.
- Install mower in reverse order of removal instructions.

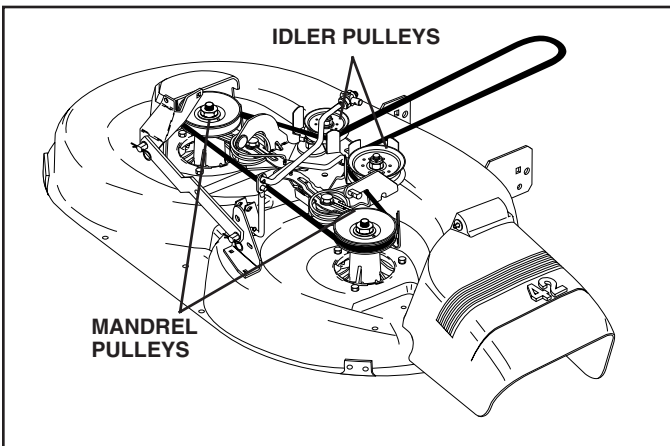

FIG. 24

TO CHECK AND ADJUST BRAKE (See Fig. 25)

Your tractor is equipped with an adjustable brake system which is mounted on the right side of the transaxle.

If tractor requires more than five (5) feet to stop at highest speed in highest gear on a level, dry concrete or paved surface, then brake must be checked and adjusted.

TO CHECK BRAKE

- Park tractor on a level, dry concrete or paved surface, depress clutch/brake pedal all the way down and engage parking brake.
- Disengage transmission by placing freewheel control in "transmission disengaged" position. Pull freewheel control out and into the slot and release so it is held in the disengaged position.

The rear wheels must lock and skid when you try to manually push the tractor forward. If the rear wheels rotate, the brake needs to be adjusted or the pads need to be replaced.

TO ADJUST BRAKE

- Depress clutch/brake pedal all the way down and engage parking brake.
- Measure distance between brake operating arm and nut "A" on brake rod.
- If distance is other than 1-9/16", loosen jam nut and turn nut "A" until distance becomes 1-9/16". Retighten jam nut against nut "A".
- Engage transmission by placing freewheel control in "transmission engaged" position.
- Road test tractor for proper stopping distance as stated above. Readjust if necessary. If stopping distance is still greater than five (5) feet in highest gear, further maintenance is necessary. Replace brake pads or contact a qualified service center.

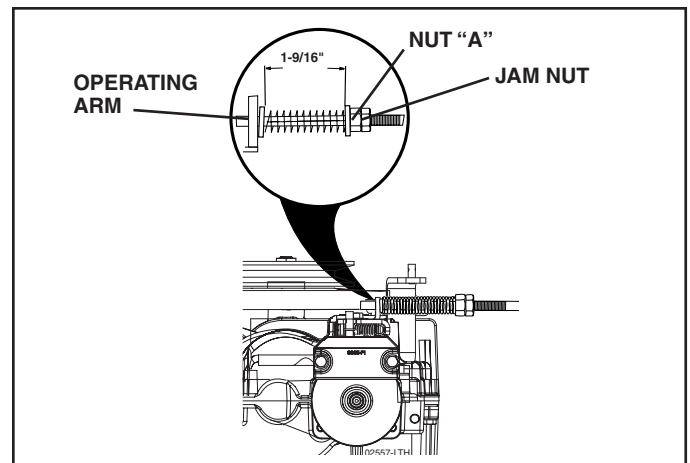

FIG. 25

SERVICE AND ADJUSTMENTS

TO REPLACE MOTION DRIVE BELT (See Fig. 26)

Park the tractor on level surface. Engage parking brake. For assistance, there is a belt installation guide decal on bottom side of left footrest.

BELT REMOVAL -

- Remove mower (See "TO REMOVE MOWER" in this section of manual).

NOTE: Observe entire motion drive belt and position of all belt guides and keepers.

- Remove belt from stationary idler and clutching idler.
- Remove belt downward from around engine pulley.
- Pull belt slack toward rear of tractor. Carefully remove belt upwards from transmission input pulley.
- Remove belt from center span keeper and pull belt away from tractor.

BELT INSTALLATION -

- Carefully work new belt down onto the input pulley.
- Slide belt into the center span keeper.
- Pull belt toward front of tractor and roll around the top groove of engine pulley.
- Install belt through stationary idler and clutching idler.
- Make sure belt is in all pulley grooves and inside all belt guides and keepers.
- Install mower (See "TO INSTALL MOWER" in this section of manual).

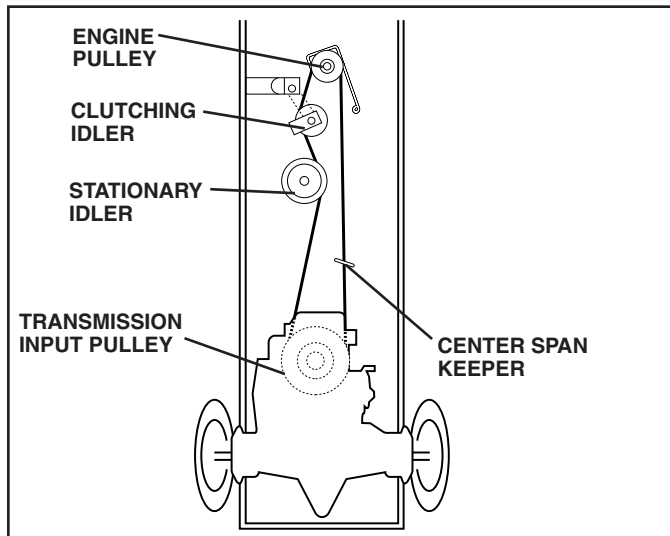

FIG. 26

TRANSAXLE MOTION CONTROL LEVER NEUTRAL ADJUSTMENT(See Fig. 27)

The motion control lever has been preset at the factory and adjustment should not be necessary.

- Loosen adjustment bolt in front of the right rear wheel, and lightly tighten.
- Start engine and move motion control lever until tractor does not move forward or backward.
- Hold motion control lever in that position and turn engine off.
- While holding motion control lever in place, loosen the adjustment bolt.
- Move motion control lever to the neutral (N) (lock gate) position.
- Tighten adjustment bolt securely.

NOTE: If additional clearance is needed to get to adjustment bolt, move mower deck height to the lowest position.

After above adjustment is made, if the tractor still creeps forward or backward while motion control lever is in neutral position, follow these steps:

- Loosen the adjustment bolt.
- Move the motion control lever 1/4 to 1/2 inch in the direction it is trying to creep.
- Tighten adjustment bolt securely.
- Start engine and test.
- If tractor still creeps, repeat above steps until satisfied.

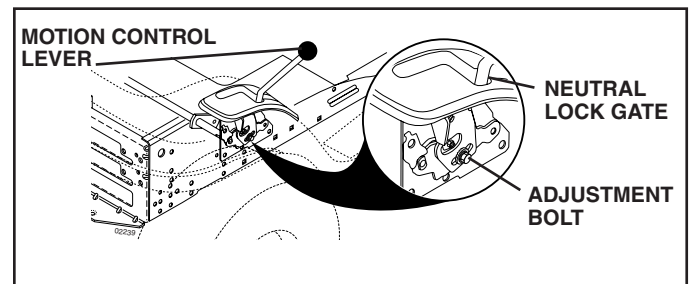

FIG. 27

TRANSMISSION REMOVAL/REPLACEMENT

Should your transmission require removal for service or replacement, it should be purged after reinstallation and before operating the tractor. See "PURGETRANSMISSION" in the Operation section of this manual.

TO ADJUST STEERING WHEEL ALIGNMENT

If steering wheel crossbars are not horizontal (left to right) when wheels are positioned straight forward, remove steering wheel and reassemble per instructions in the Assembly section of this manual.

FRONT WHEEL TOE-IN/CAMBER

The front wheel toe-in and camber are not adjustable on your tractor. If damage has occurred to affect the front wheel toe-in or camber, contact your nearest authorized service center/department.

SERVICE AND ADJUSTMENTS

TO REMOVE WHEEL FOR REPAIRS

(See Fig. 28)

- Block up axle securely.
- Remove axle cover, retaining ring and washers to allow wheel removal (rear wheel contains a square key - Do not lose).
- Repair tire and reassemble.
- On rear wheels only: align grooves in rear wheel hub and axle. Insert square key.
- Replace washers and snap retaining ring securely in axle groove.
- Replace axle cover.

NOTE: To seal tire punctures and prevent flat tires due to slow leaks, tire sealant may be purchased from your local parts dealer. Tire sealant also prevents tire dry rot and corrosion.

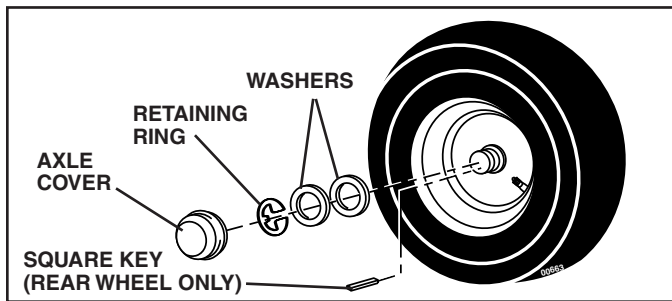

FIG. 28

TO START ENGINE WITH A WEAK BATTERY

(See Fig. 29)



WARNING: Lead-acid batteries generate explosive gases. Keep sparks, flame and smoking materials away from batteries. Always wear eye protection when around batteries.

If your battery is too weak to start the engine, it should be recharged. (See "BATTERY" in the Maintenance section of this manual).

If "jumper cables" are used for emergency starting, follow this procedure:

IMPORTANT: YOUR TRACTOR IS EQUIPPED WITH A 12 VOLT SYSTEM. THE OTHER VEHICLE MUST ALSO BE A 12 VOLT SYSTEM. DO NOT USE YOUR TRACTOR BATTERY TO START OTHER VEHICLES.

TO ATTACH JUMPER CABLES -

- Connect one end of the RED cable to the POSITIVE (+) terminal of each battery (A-B), taking care not to short against tractor chassis.
- Connect one end of the BLACK cable to the NEGATIVE (-) terminal (C) of fully charged battery.
- Connect the other end of the BLACK cable (D) to good chassis ground, away from fuel tank and battery.

TO REMOVE CABLES, REVERSE ORDER -

- BLACK cable first from chassis and then from the fully charged battery.
- RED cable last from both batteries.

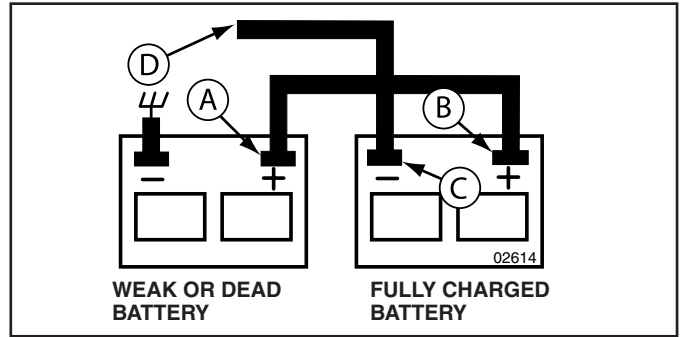

FIG. 29

TO REPLACE HEADLIGHT BULB

- Raise hood.
- Pull bulb holder out of the hole in the backside of the grill.
- Replace bulb in holder and push bulb holder securely back into the hole in the backside of the grill.
- Close hood.

INTERLOCKS AND RELAYS

Loose or damaged wiring may cause your tractor to run poorly, stop running, or prevent it from starting.

- Check wiring. See electrical wiring diagram in the Repair Parts section.

TO REPLACE FUSE

Replace with 20 amp automotive-type plug-in fuse. The fuse holder is located behind the dash.

TO REMOVE HOOD AND GRILL ASSEMBLY (See Fig. 30)

- Raise hood.
- Unsnap headlight wire connector.
- Stand in front of tractor. Grasp hood at sides, tilt toward engine and lift off of tractor.
- To replace, reverse above procedure.

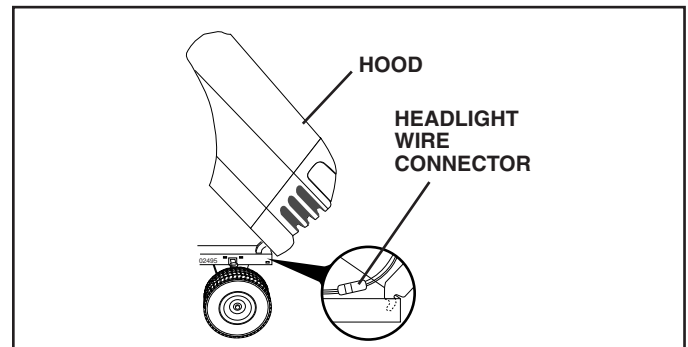

FIG. 30

SERVICE AND ADJUSTMENTS

ENGINE

TO ADJUST THROTTLE CONTROL CABLE (See Fig. 31)

The throttle control has been preset at the factory and adjustment should not be necessary. Check adjustment as described below before loosening cable. If adjustment is necessary, proceed as follows:

- With engine not running, move throttle control lever to fast position.
- Check that swivel is against stop. If it is not, loosen cable clamp screw and pull cable back until swivel is against stop. Tighten cable clamp screw securely.

TO ADJUST CHOKE CONTROL (See Fig. 32)

The choke control has been preset at the factory and adjustment should not be necessary. Check adjustment as described below before loosening cable. If adjustment is necessary, proceed as follows:

- With engine not running, move choke control (located on dash panel) to full choke position.
- Loosen knob and remove cover assembly from air cleaner.
- Choke should be closed. If it is not, loosen casing clamp screw and move choke cable until choke is completely closed. Tighten casing clamp screw securely.
- Replace air cleaner cover assembly and tighten knob.

TO ADJUST CARBURETOR

Your carburetor is not adjustable. If your engine does not operate properly due to suspected carburetor problems, take your tractor to an authorized service center for repair and/or adjustment.

High speed stop is factory adjusted. Do not adjust - damage may result.

IMPORTANT: NEVER TAMPER WITH THE ENGINE GOVERNOR, WHICH IS FACTORY SET FOR PROPER ENGINE SPEED. OVERSPEEDING THE ENGINE ABOVE THE FACTORY HIGH SPEED SETTING CAN BE DANGEROUS. IF YOU THINK THE ENGINE-GOVERNED HIGH SPEED NEEDS ADJUSTING, CONTACT YOUR NEAREST AUTHORIZED SERVICE CENTER/DEPARTMENT, WHICH HAS PROPER EQUIPMENT AND EXPERIENCE TO MAKE ANY NECESSARY ADJUSTMENTS.

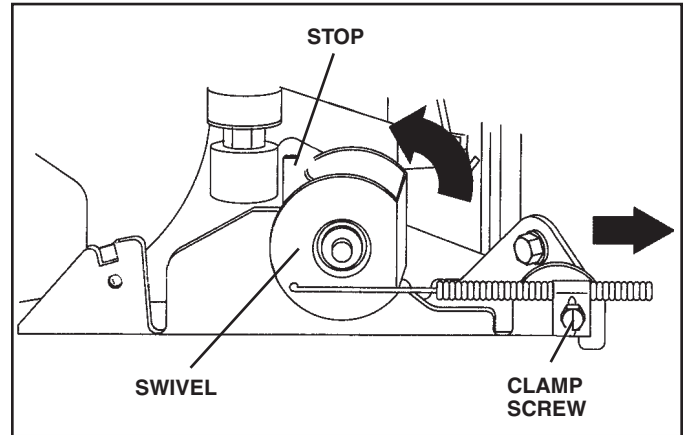

FIG. 31

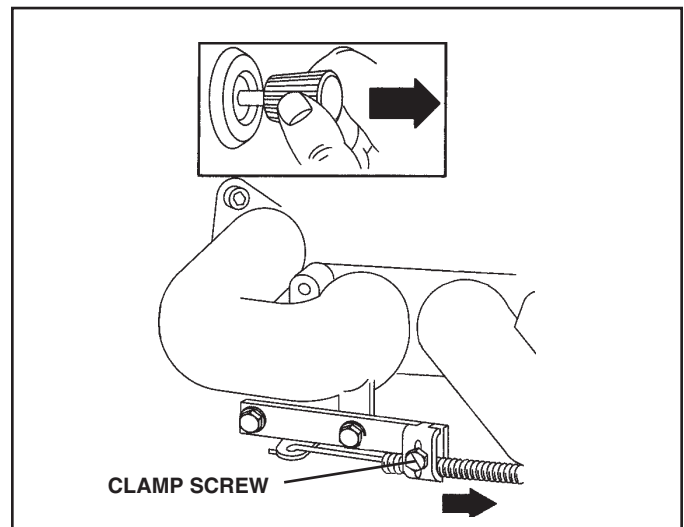

FIG. 32

STORAGE

Immediately prepare your tractor for storage at the end of the season or if the tractor will not be used for 30 days or more.



WARNING: Never store the tractor with gasoline in the tank inside a building where fumes may reach an open flame or spark. Allow the engine to cool before storing in any enclosure.

TRACTOR

Remove mower from tractor for winter storage. When mower is to be stored for a period of time, clean it thoroughly, remove all dirt, grease, leaves, etc. Store in a clean, dry area.

- Clean entire tractor (See “CLEANING” in the Maintenance section of this manual).
- Inspect and replace belts, if necessary (See belt replacement instructions in the Service and Adjustments section of this manual).
- Lubricate as shown in the Maintenance section of this manual.
- Be sure that all nuts, bolts and screws are securely fastened. Inspect moving parts for damage, breakage and wear. Replace if necessary.
- Touch up all rusted or chipped paint surfaces; sand lightly before painting.

BATTERY

- Fully charge the battery for storage.
- After a period of time in storage, battery may require recharging.
- To help prevent corrosion and power leakage during long periods of storage, battery cables should be disconnected and battery cleaned thoroughly (see “TO CLEAN BATTERY AND TERMINALS” in the Maintenance section of this manual).
- After cleaning, leave cables disconnected and place cables where they cannot come in contact with battery terminals.
- If battery is removed from tractor for storage, do not store battery directly on concrete or damp surfaces.

ENGINE

FUEL SYSTEM

IMPORTANT: IT IS IMPORTANT TO PREVENT GUM DEPOSITS FROM FORMING IN ESSENTIAL FUEL SYSTEM PARTS SUCH AS CARBURETOR, FUEL FILTER, FUEL HOSE, OR TANK DURING STORAGE. ALSO, EXPERIENCE INDICATES THAT ALCOHOL BLENDED FUELS (CALLED GASOHOL OR USING ETHANOL OR METHANOL) CAN ATTRACT MOISTURE WHICH LEADS TO SEPARATION AND FORMATION OF ACIDS DURING STORAGE. ACIDIC GAS CAN DAMAGE THE FUEL SYSTEM OF AN ENGINE WHILE IN STORAGE.

- Empty the fuel tank by starting the engine and let it run until the fuel lines and carburetor are empty.
- Never use engine or carburetor cleaner products in the fuel tank or permanent damage may occur.
- Use fresh fuel next season.

NOTE: Fuel stabilizer is an acceptable alternative in minimizing the formation of fuel gum deposits during storage. Add stabilizer to gasoline in fuel tank or storage container. Always follow the mix ratio found on stabilizer container. Run engine at least 10 minutes after adding stabilizer to allow the stabilizer to reach the carburetor. Do not empty the gas tank and carburetor if using fuel stabilizer.

ENGINE OIL

Drain oil (with engine warm) and replace with clean engine oil. (See “ENGINE” in the Maintenance section of this manual).

CYLINDER(S)

- Remove spark plug(s).
- Pour one ounce of oil through spark plug hole(s) into cylinder(s).
- Turn ignition key to “START” position for a few seconds to distribute oil.
- Replace with new spark plug(s).

OTHER

- Do not store gasoline from one season to another.
- Replace your gasoline can if your can starts to rust. Rust and/or dirt in your gasoline will cause problems.
- If possible, store your tractor indoors and cover it to give protection from dust and dirt.
- Cover your tractor with a suitable protective cover that does not retain moisture. Do not use plastic. Plastic cannot breathe which allows condensation to form and will cause your tractor to rust.

IMPORTANT: NEVER COVER TRACTOR WHILE ENGINE AND EXHAUST AREAS ARE STILL WARM.

TROUBLESHOOTING POINTS

| PROBLEM | CAUSE | CORRECTION |
|---|---|--|
| Will not start | <ol style="list-style-type: none"> 1. Out of fuel. 2. Engine not "CHOKED" properly. 3. Engine flooded. 4. Bad spark plug. 5. Dirty air filter. 6. Dirty fuel filter. 7. Water in fuel. 8. Loose or damaged wiring. 9. Carburetor out of adjustment. 10. Engine valves out of adjustment. | <ol style="list-style-type: none"> 1. Fill fuel tank. 2. See "TO START ENGINE" in Operation section. 3. Wait several minutes before attempting to start. 4. Replace spark plug. 5. Clean/replace air filter. 6. Replace fuel filter. 7. Empty fuel tank and carburetor, refill tank with fresh gasoline and replace fuel filter. 8. Check all wiring. 9. See "To Adjust Carburetor" in Service Adjustments section. 10. Contact an authorized service center/department. |
| Hard to start | <ol style="list-style-type: none"> 1. Dirty air filter. 2. Bad spark plug. 3. Weak or dead battery. 4. Dirty fuel filter. 5. Stale or dirty fuel. 6. Loose or damaged wiring. 7. Carburetor out of adjustment. 8. Engine valves out of adjustment. | <ol style="list-style-type: none"> 1. Clean/replace air filter. 2. Replace spark plug. 3. Recharge or replace battery. 4. Replace fuel filter. 5. Empty fuel tank and refill tank with fresh, clean gasoline. 6. Check all wiring. 7. See "To Adjust Carburetor" in Service Adjustments section. 8. Contact an authorized service center/department. |
| Engine will not turn over | <ol style="list-style-type: none"> 1. Brake pedal not depressed. 2. Attachment clutch is engaged. 3. Weak or dead battery. 4. Blown fuse. 5. Corroded battery terminals. 6. Loose or damaged wiring. 7. Faulty ignition switch. 8. Faulty solenoid or starter. 9. Faulty operator presence switch(es). | <ol style="list-style-type: none"> 1. Depress brake pedal. 2. Disengage attachment clutch. 3. Recharge or replace battery. 4. Replace fuse. 5. Clean battery terminals. 6. Check all wiring. 7. Check/replace ignition switch. 8. Check/replace solenoid or starter. 9. Contact an authorized service center/department. |
| Engine clicks but will not start | <ol style="list-style-type: none"> 1. Weak or dead battery. 2. Corroded battery terminals. 3. Loose or damaged wiring. 4. Faulty solenoid or starter. | <ol style="list-style-type: none"> 1. Recharge or replace battery. 2. Clean battery terminals. 3. Check all wiring. 4. Check/replace solenoid or starter. |
| Loss of power | <ol style="list-style-type: none"> 1. Cutting too much grass/too fast. 2. Throttle in "CHOKE" position. 3. Build-up of grass, leaves and trash under mower. 4. Dirty air filter. 5. Low oil level/dirty oil. 6. Faulty spark plug. 7. Dirty fuel filter. 8. Stale or dirty fuel. 9. Water in fuel. 10. Spark plug wire loose. 11. Dirty engine air screen/fins. 12. Dirty/clogged muffler. 13. Loose or damaged wiring. 14. Carburetor out of adjustment. 15. Engine valves out of adjustment. | <ol style="list-style-type: none"> 1. Raise cutting height/reduce speed. 2. Adjust throttle control. 3. Clean underside of mower housing. 4. Clean/replace air filter. 5. Check oil level/change oil. 6. Clean and regap or change spark plug. 7. Replace fuel filter. 8. Empty fuel tank and refill tank with fresh, clean gasoline. 9. Empty fuel tank and carburetor, refill tank with fresh gasoline and replace fuel filter. 10. Connect and tighten spark plug wire. 11. Clean engine air screen/fins. 12. Clean/replace muffler. 13. Check all wiring. 14. See "To Adjust Carburetor" in Service Adjustments section. 15. Contact an authorized service center/department. |
| Excessive vibration | <ol style="list-style-type: none"> 1. Worn, bent or loose blade. 2. Bent blade mandrel. 3. Loose/damaged part(s). | <ol style="list-style-type: none"> 1. Replace blade. Tighten blade bolt. 2. Replace blade mandrel. 3. Tighten loose part(s). Replace damaged parts. |

TROUBLESHOOTING POINTS

| PROBLEM | CAUSE | CORRECTION |
|--|---|--|
| Engine dies when tractor is shifted into reverse | <ol style="list-style-type: none"> Reverse operation system (ROS) is not "ON" while mower or other attachment is engaged. | <ol style="list-style-type: none"> Turn ignition key to ROS "ON" position. See Operation section. |
| Engine continues to run when operator leaves seat with attachment clutch engaged | <ol style="list-style-type: none"> Faulty operator-safety presence control system. | <ol style="list-style-type: none"> Check wiring, switches and connections. If not corrected, contact an authorized service center/department. |
| Poor cut - uneven | <ol style="list-style-type: none"> Worn, bent or loose blade. Mower deck not level. Buildup of grass, leaves, and trash under mower. Bent blade mandrel. Clogged mower deck vent holes from buildup of grass, leaves, and trash around mandrels. | <ol style="list-style-type: none"> Replace blade. Tighten blade bolt. Level mower deck. Clean underside of mower housing. Replace blade mandrel. Clean around mandrels to open vent holes. |
| Mower blades will not rotate | <ol style="list-style-type: none"> Obstruction in clutch mechanism. Worn/damaged mower drive belt. Frozen idler pulley. Frozen blade mandrel. | <ol style="list-style-type: none"> Remove obstruction. Replace mower drive belt. Replace idler pulley. Replace blade mandrel. |
| Poor grass discharge | <ol style="list-style-type: none"> Engine speed too slow. Travel speed too fast. Wet grass. Mower deck not level. Low/uneven tire air pressure. Worn, bent or loose blade. Buildup of grass, leaves and trash under mower. Mower drive belt worn. Blades improperly installed. Improper blades used. Clogged mower deck vent holes from buildup of grass, leaves, and trash around mandrels. | <ol style="list-style-type: none"> Place throttle control in "FAST" position. Shift to slower speed. Allow grass to dry before mowing. Level mower deck. Check tires for proper air pressure. Replace/sharpen blade. Tighten blade bolt. Clean underside of mower housing. Replace mower drive belt. Reinstall blades sharp edge down. Replace with blades listed in this manual. Clean around mandrels to open vent holes. |
| Headlight(s) not working (if so equipped) | <ol style="list-style-type: none"> Light switch is "OFF". Bulb(s) or lamp(s) burned out. Faulty light switch. Loose or damaged wiring. Blown fuse. | <ol style="list-style-type: none"> Turn light switch "ON". Replace bulb(s) or lamp(s). Check/replace light switch. Check wiring and connections. Replace fuse. |
| Battery will not charge | <ol style="list-style-type: none"> Bad battery cell(s). Poor cable connections. Faulty regulator (if so equipped). Faulty alternator. | <ol style="list-style-type: none"> Replace battery. Check/clean all connections. Replace regulator. Replace alternator. |
| Loss of drive | <ol style="list-style-type: none"> Freewheel control in "disengaged" position. Motion drive belt worn, damaged, or broken. Air trapped in transmission during shipment or servicing. | <ol style="list-style-type: none"> Place freewheel control in "engaged" position. Replace motion drive belt. Purge transmission. |
| Engine "backfires" when turning engine "OFF" | <ol style="list-style-type: none"> Engine throttle control not set between half and full speed (fast) position before stopping engine. | <ol style="list-style-type: none"> Move throttle control between half and full speed (fast) position before stopping engine. |

TRACTOR - - MODEL NUMBER 944.605931

SCHEMATIC

03059_197428

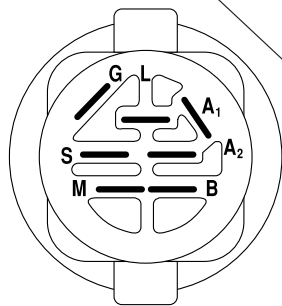
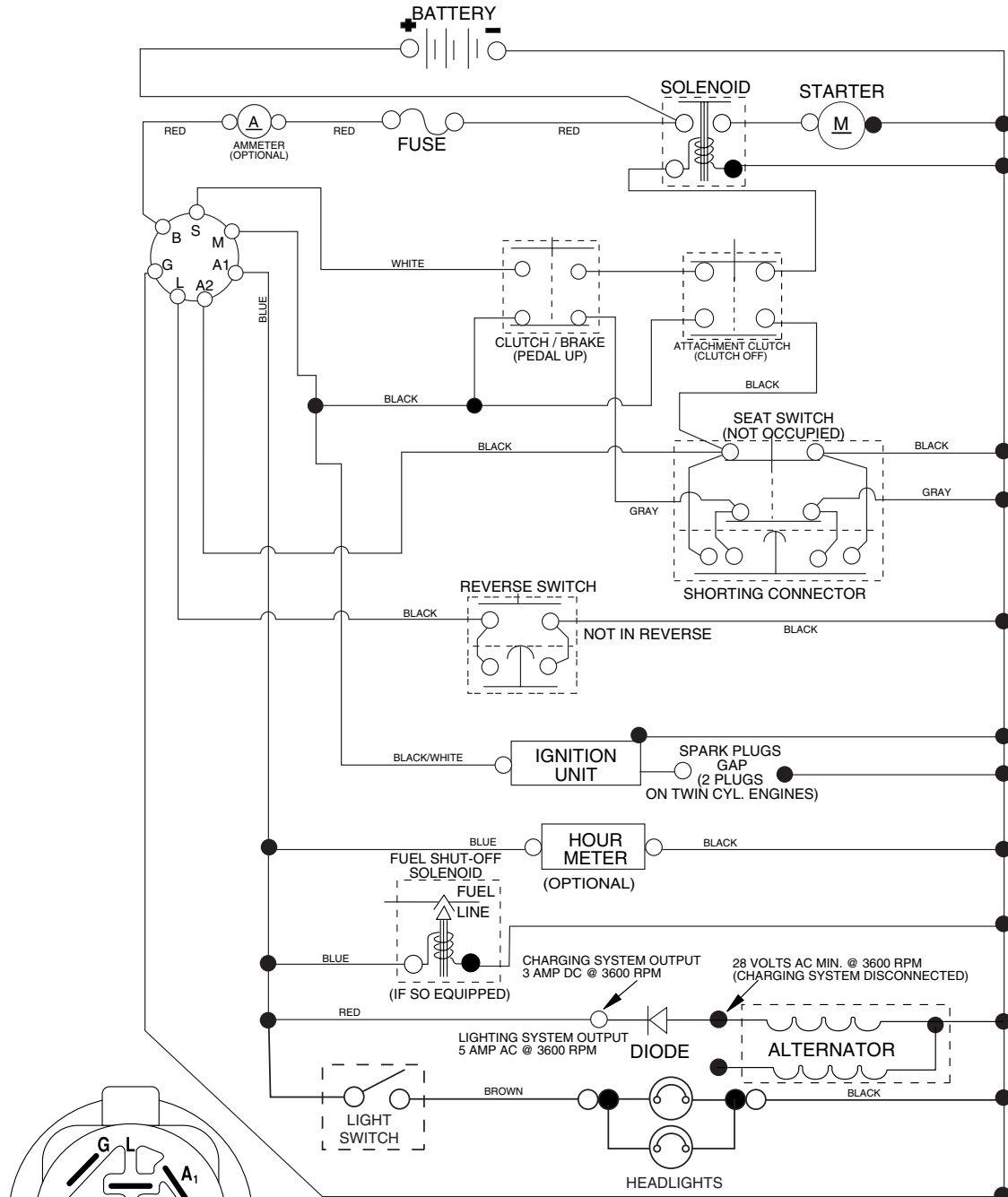

IGNITION SWITCH

| POSITION | CIRCUIT | "MAKE" |
|--------------|------------|--------|
| OFF | M+G+A1 | |
| RUN/OVERRIDE | B+A1 | |
| RUN | B+A1 | L+A2 |
| START | B + S + A1 | |

03059

NOTE

YOUR TRACTOR IS EQUIPPED WITH A SPECIAL ALTERNATOR SYSTEM. THE LIGHTS ARE NOT CONNECTED TO THE BATTERY, BUT HAVE THEIR OWN ELECTRICAL SOURCE.

BECAUSE OF THIS, THE BRIGHTNESS OF THE LIGHTS WILL CHANGE WITH ENGINE SPEED. AT IDLE THE LIGHTS WILL DIM. AS THE ENGINE IS SPEEDED UP, THE LIGHTS WILL BECOME THEIR BRIGHTEST.

●
NON-REMOVABLE CONNECTIONS

○
REMOVABLE CONNECTIONS

WIRING INSULATED CLIPS

NOTE: IF WIRING INSULATED CLIPS WERE REMOVED FOR SERVICING OF UNIT, THEY SHOULD BE REPLACED TO PROPERLY SECURE YOUR WIRING.

REPAIR PARTS

TRACTOR - - MODEL NUMBER 944.605931

ELECTRICAL

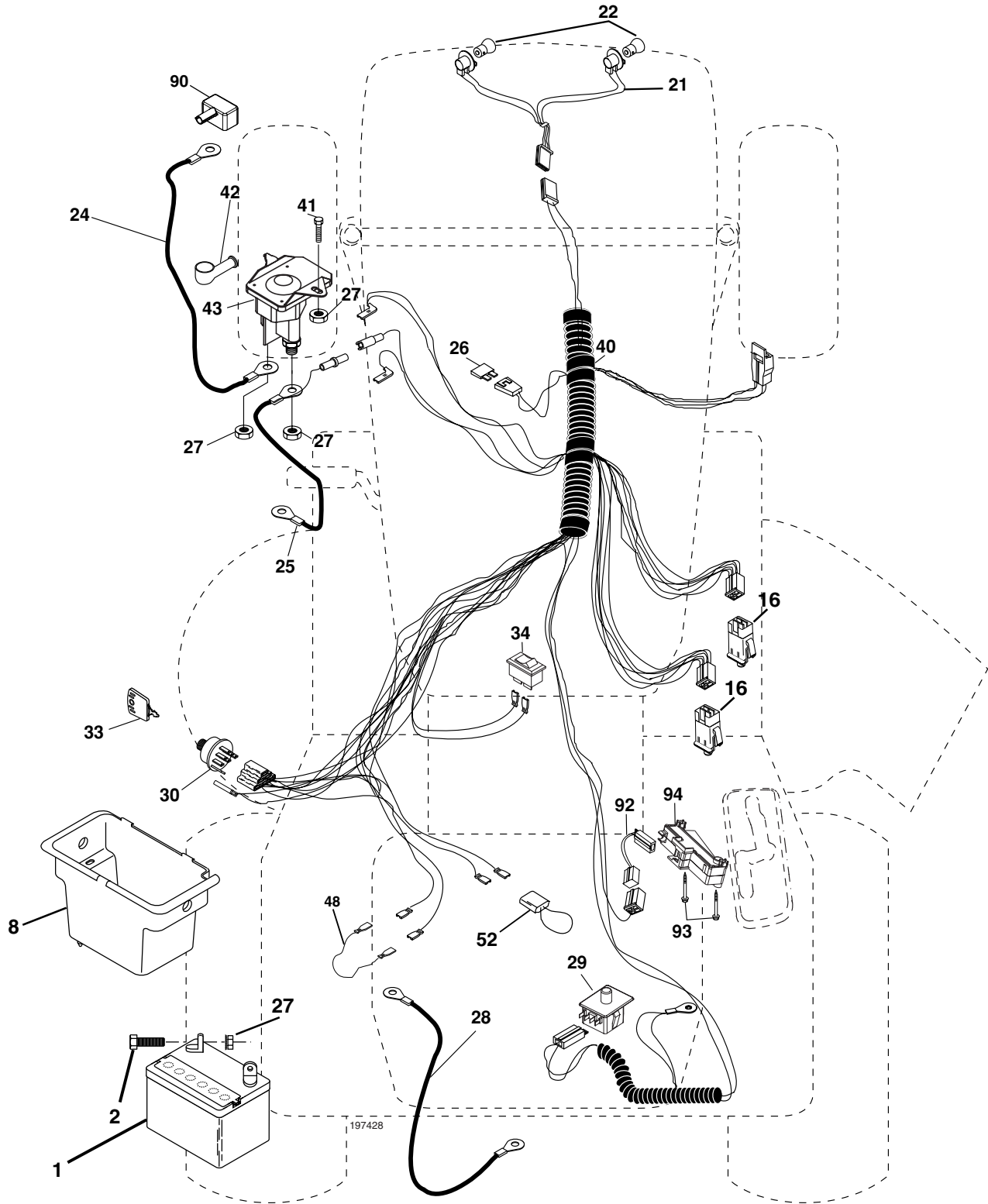

REPAIR PARTS

TRACTOR - - MODEL NUMBER 944.605931

ELECTRICAL

| KEY NO. | PART NO. | DESCRIPTION |
|---------|---------------|-----------------------------------|
| 1 | 144927 | Battery |
| 2 | 74760412 | Bolt Hex Hd 1/4-20 unc x 3/4 |
| 8 | 176689 | Case Battery |
| 16 | 176138 | Switch Interlock Push-In |
| 21 | 183759 | Harness Asm Light W/4152J |
| 22 | 4152J | Bulb Light #1156 |
| 24 | 4799J | Cable Battery 6 Ga. 11"red |
| 25 | 146147 | Cable Battery 6 Ga. w/16 wire,red |
| 26 | 175158 | Fuse 20 AMP |
| 27 | 73510400 | Nut Kep Hex 1/4-20 |
| 28 | 4207J | Cable Ground 6 Ga. 12" black |
| 29 | 192749 | Switch Seat DP. W/ROS |
| 30 | 193350 | Switch Ignition |
| 33 | 140403 | Key Ignition |
| 34 | 110712X | Switch Light/Reset |
| 40 | 197428 | Harness Ign |
| 41 | 71110408 | Bolt Blk Fin Hex 1/4-20 unc x 1/2 |
| 42 | 131563 | Cover Terminal Red |
| 43 | 192507 | Solenoid |
| 48 | 140844 | Adapter Ammeter |
| 52 | 141940 | Protection Wire Loop (Hourmeter) |
| 90 | 180449 | Cover Terminal Battery |
| 92 | 196615 | Harness Pigtail Reverse Switch |
| 93 | 192540 | Screw Plastite 10-14 x 2.0 |
| 94 | 191834 | Module Reverse ROS |

NOTE: All component dimensions give in U.S. inches
1 inch = 25.4 mm.

REPAIR PARTS

TRACTOR - - MODEL NUMBER 944.605931

CHASSIS AND ENCLOSURES

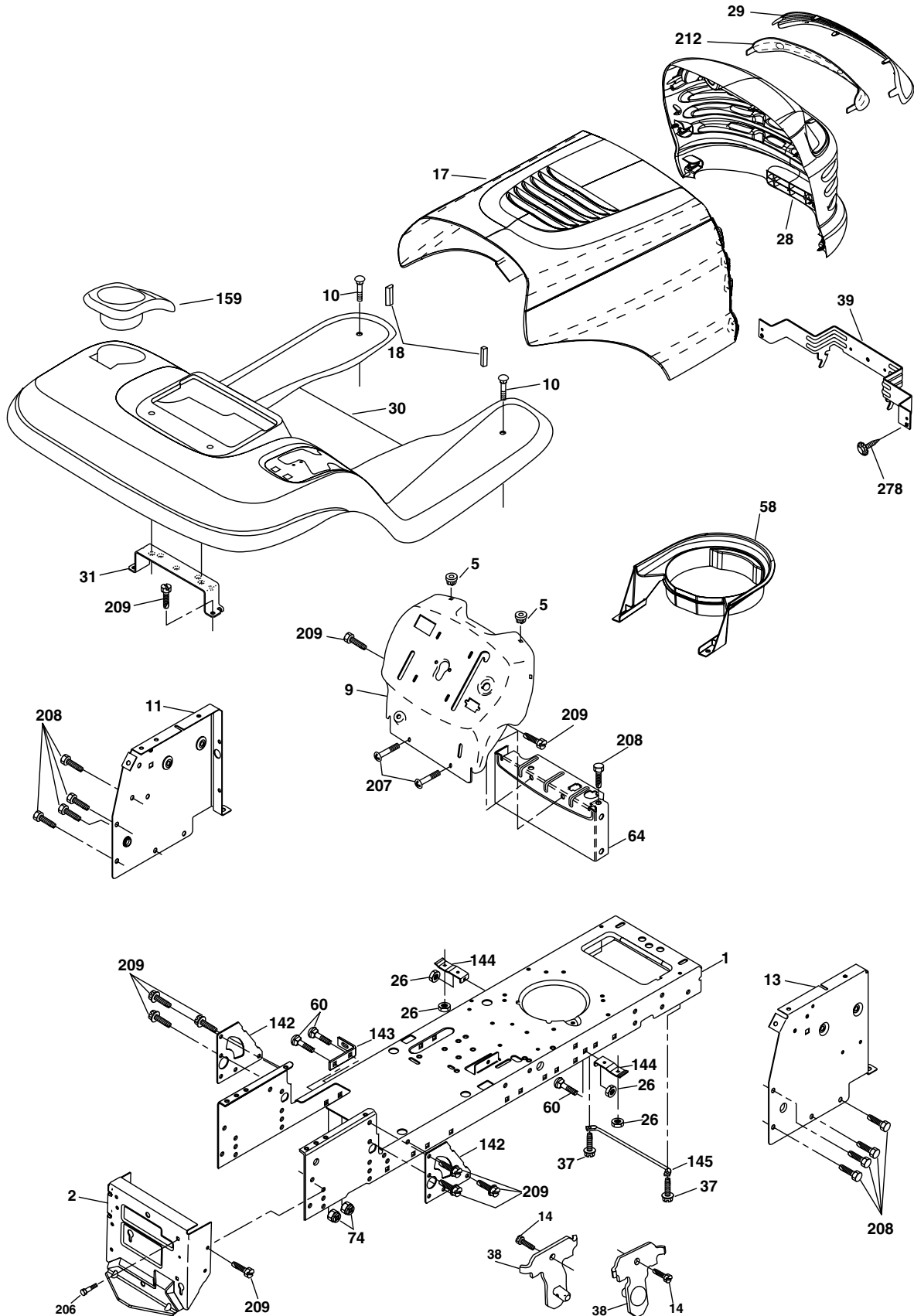

chassis-Laser -lt.stlt_50

REPAIR PARTS

TRACTOR - - MODEL NUMBER 944.605931

CHASSIS AND ENCLOSURES

| KEY NO. | PART NO. | DESCRIPTION |
|---------|------------|--|
| 1 | 174619 | Chassis |
| 2 | 176554 | Drawbar |
| 5 | 155272 | Bumper Hood/Dash |
| 9 | 193510X014 | Dash |
| 10 | STD533710 | Bolt Carriage 3/8-16 x 1 |
| 11 | 174996 | Panel Dash Lh |
| 13 | 172105X010 | Panel Dash Rh |
| 14 | 17490608 | Screw Thdrol 3/8-16 x 1/2 |
| 17 | 185682X613 | Hood |
| 18 | 184921 | Bumper Hood |
| 26 | STD541437 | Nut Lock Hex W/Ins 3/8-16 unc |
| 28 | 193258 | Grille/Len Laser (Includes Key Nos. 212, and 29) |
| 29 | 174332X599 | Lens Grille |
| 30 | 192393X613 | Fender Footrest |
| 31 | 139976 | Bracket Support Fender |
| 37 | 17490508 | Screw Thdrol 6/16-18 x 1/2 TYT |
| 38 | 175710 | Bracket, Assembly Pivot |
| 39 | 174714 | Bracket Pivot Laser |
| 58 | 184462 | Air Duct Intake |
| 60 | STD533707 | Bolt Rdhd Sqnk 3/8-16 unc x 3/4 |
| 64 | 154798 | Dash Lower STLT |
| 74 | STD541437 | Nut Crownlock 3/8-16 unc |
| 142 | 175702 | Plate Reinforcement STLT |
| 143 | 186689 | Bracket Swaybar Chassis |
| 144 | 175582 | Bracket Pnt Footrest STLT |
| 145 | 156524 | Rod Pivot Chassis/Hood |
| 159 | 155123X428 | Cup Holder |
| 206 | 170165 | Bolt Shoulder 5/16-18 |
| 207 | 17670508 | Screw Thdrol 5/16-18 x 1/2 |
| 208 | 17670608 | Screw Thdrol 3/8-16 x 1/2 |
| 209 | 17000612 | Screw Hex Wsh Thdr. 3/8-16 x 3/4 |
| 212 | 175143 | Insert Lens Reflective |
| 278 | 191611 | Screw 10 x 3/4 Single Lead-Hex |
| - - | 5479J | Plug Button |

NOTE: All component dimensions given in U.S. inches
1 inch = 25.4 mm

REPAIR PARTS

TRACTOR - - MODEL NUMBER 944.605931

DRIVE

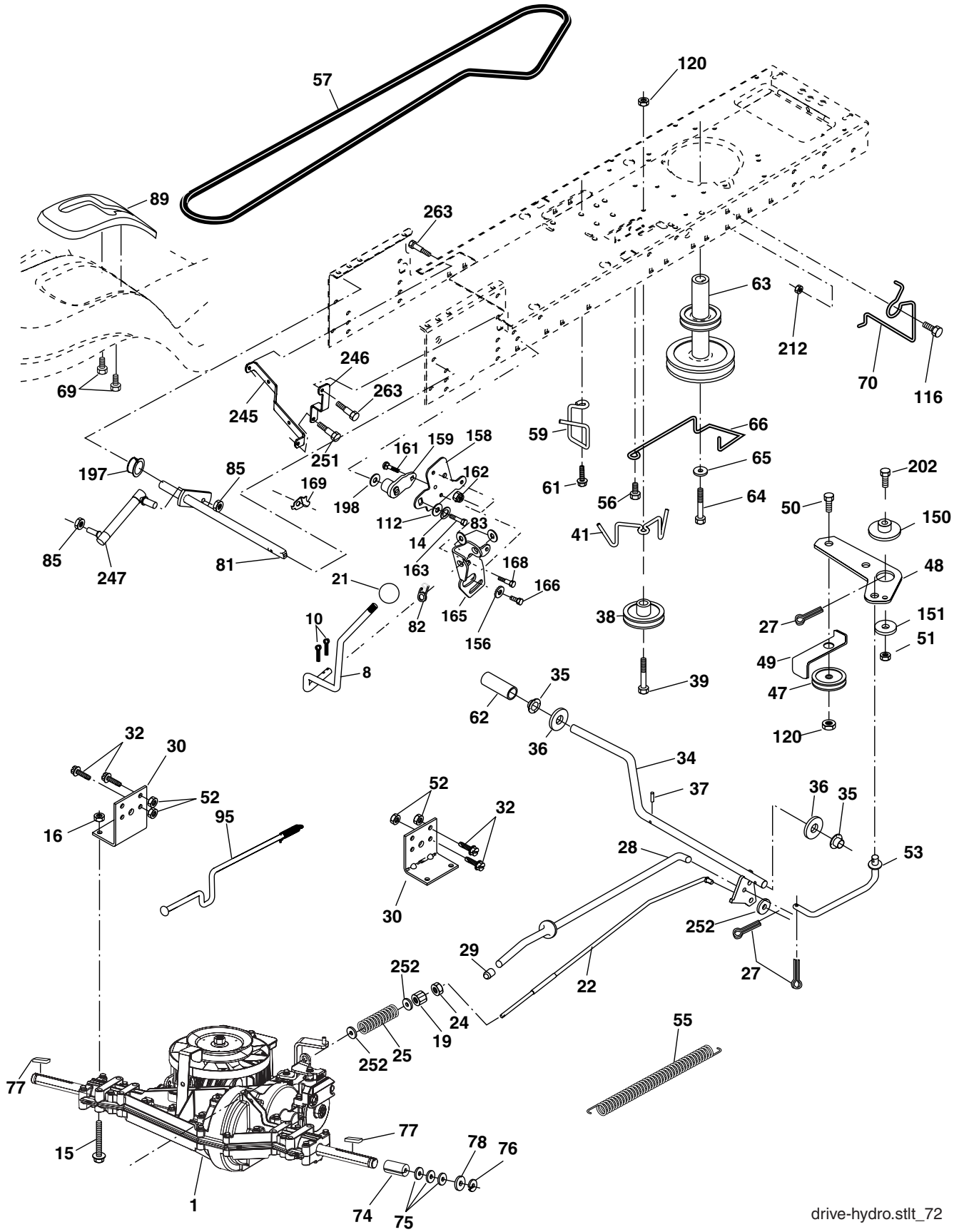

drive-hydro.stlt_72

REPAIR PARTS

TRACTOR - - MODEL NUMBER 944.605931

DRIVE

| KEY PART NO. NO. | DESCRIPTION | KEY PART NO. NO. | DESCRIPTION |
|---------------------|---------------|---------------------|--|
| 1 | ----- | 69 | 142432 Screw Hex Wsh Hi-Lo 1/4-1/2 unc |
| 8 | 192502 | 70 | 134683 Keeper Belt Engine |
| 10 | STD561210 | 74 | 137057 Spacer |
| 14 | 10040400 | 75 | 121749X Washer 25/32 x 1-1/4 x 16 Ga. |
| 15 | 74490544 | 76 | STD581075 E-Ring |
| 16 | STD541431 | 77 | 123583X Key, Square |
| 19 | STD541437 | 78 | 121748X Washer 25/32 x 1-5/8 x 16 Ga. |
| 21 | 130564 | 81 | 178139 Shaft Asm Cross Tapered |
| 22 | 178141 | 82 | 165711 Spring Torsion |
| 24 | 73350600 | 83 | 19171216 Washer 17/32 x 3/4 x 16 Ga. |
| 25 | 106888X | 85 | 150360 Nut Lock Center 1/4-28 FNTHD |
| 27 | STD561210 | 89 | 192387X428 Console, Shift |
| 28 | 175765 | 95 | 178134 Disconnect Asm Rod Bypass LTH |
| 29 | 71673 | 112 | 19091210 Washer 9/32 x 3/4 x 10 Ga. |
| 30 | 169592 | 116 | 72140608 Bolt Rdhd Sqneck 3/8-16 x 1 |
| 32 | 74760512 | 120 | 73900600 Nut Lock Flg 3/8-16 |
| 34 | 175578 | 150 | 175456 Spacer Retainer |
| 35 | 120183X | 151 | 19133210 Washer 13/32 x 2 x 10 Ga. |
| 36 | 19211616 | 156 | 166002 Washer Srrted 5/16 ID x 1.125 |
| 37 | 1572H | 158 | 165589 Bracket Shift Mount |
| 38 | 179114 | 159 | 183900 Hub Shift |
| 39 | 72110622 | 161 | 72140406 Bolt Rdhd Sqnk 1/4-20 x 3/4 Gr. 5 |
| 41 | 175556 | 162 | 73680400 Nut Crownlock 1/4-20 unc |
| 47 | 127783 | 163 | 74780416 Bolt Hex Fin 1/4-20 unc x 1 Gr. 5 |
| 48 | 154407 | 165 | 165623 Bracket Pivot Lever |
| 49 | 123205X | 166 | 17490510 Screw 5/16-18 x 5/8 |
| 50 | 72110612 | 168 | 165492 Bolt Shoulder 5/16-18 x .561 |
| 51 | STD541437 | 169 | 165580 Plate Fastening |
| 52 | STD541431 | 197 | 169613 Nyliner Snap-In 5/8"ID |
| 53 | 199652 | 198 | 169593 Washer Nyl 7/8 ID x 105" |
| 55 | 105709X | 202 | 72110614 Bolt Carr Sh 3/8-16 x 1-3/4 Gr.5 |
| 56 | 17060620 | 212 | 145212 Nut Hex Flange Lock |
| 57 | 178138 | 245 | 178122 Strap Torque Lh LTH2000 |
| 59 | 169691 | 246 | 178121 Strap Torque Rh LTH2000 |
| 61 | 17120614 | 247 | 181462 Link Shift Transaxle LTH2000 |
| 62 | 8883R | 251 | 17060516 Screw 5/16-18 x 1 |
| 63 | 175410 | 252 | 19131616 Washer 13/32 x 1 x 16 Ga. |
| 64 | 173937 | 263 | 17000612 Screw Hex Wsh Thdr 3/8-16 x 3/4 |
| 65 | STD551143 | | |
| 66 | 154778 | | |

NOTE: All component dimensions given in U.S. inches
1 inch = 25.4 mm

REPAIR PARTS

TRACTOR - - MODEL NUMBER 944.605931

STEERING ASSEMBLY

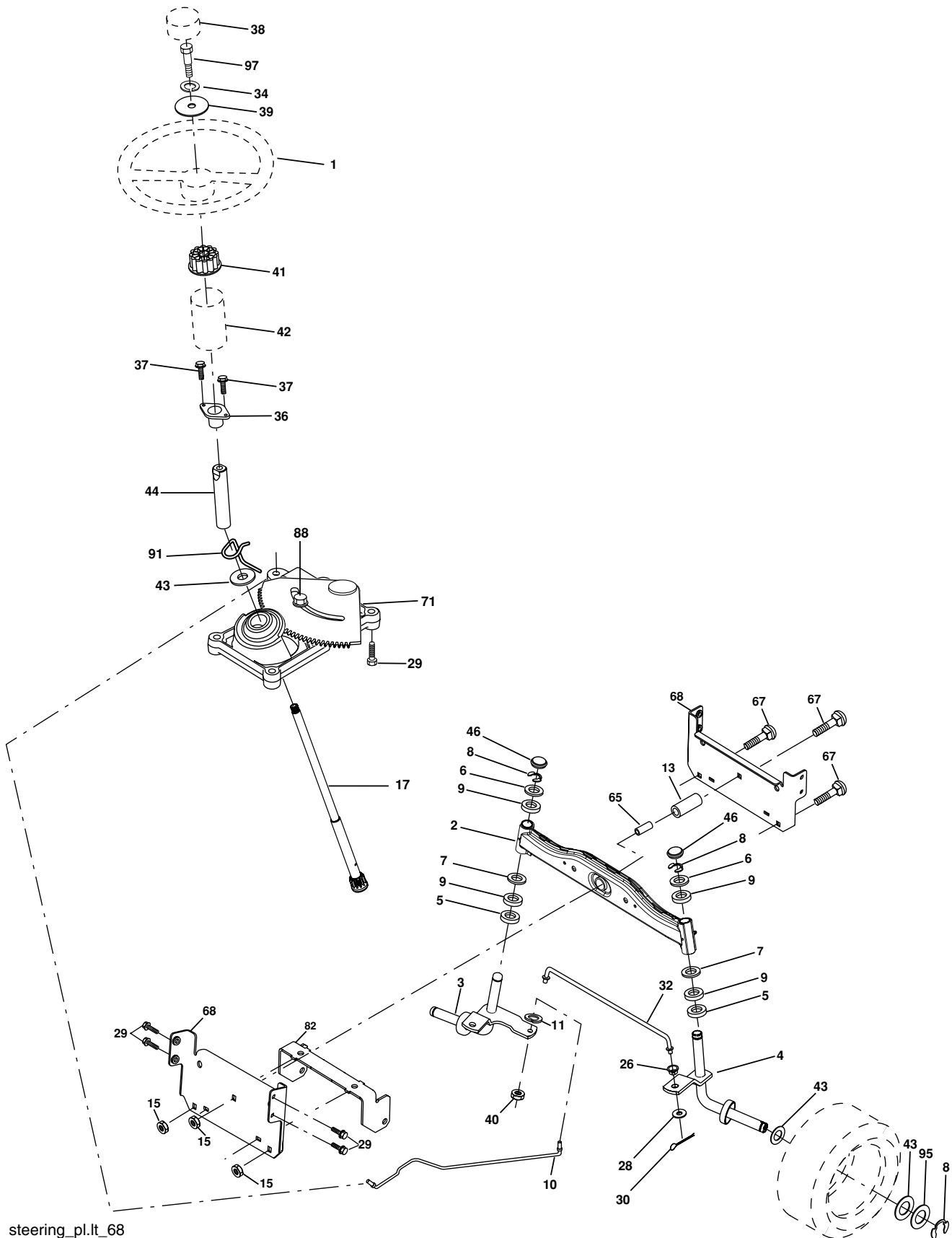

steering_pl.lt_68

REPAIR PARTS

TRACTOR - - MODEL NUMBER 944.605931

STEERING ASSEMBLY

| KEY NO. | PART NO. | DESCRIPTION |
|---------|---------------|-----------------------------------|
| 1 | 186780 | Wheel Steering |
| 2 | 195673 | Axle Asm |
| 3 | 169840 | Spindle Asm LH |
| 4 | 169839 | Spindle Asm RH |
| 5 | 6266H | Bearing Race Thrust Harden |
| 6 | 121748X | Washer 25/32 x 1-5/8 x 16 Ga. |
| 7 | 19272016 | Washer 27/32 x 1-1/4 x 16 Ga. |
| 8 | 12000029 | Ring Klip #t5304-75 |
| 9 | 3366R | Bearing Steering |
| 10 | 175121 | Link Drag Extended Stamp |
| 11 | STD551137 | Washer Lock Hvy Hlcl Spr 3/8 |
| 13 | 136518 | Spacer Bearing Axle |
| 15 | 145212 | Nut Hex Flange Lock |
| 17 | 190753 | Shaft Asm Strg |
| 26 | 126847X | Bushing Link Drag Blk LR |
| 28 | 19131416 | Washer 13/32 x 7/8 x 16 Ga. |
| 29 | 17000612 | Screw 3/8-16 x 3/4 |
| 30 | STD561210 | Pin Cotter 1/8 x 3/4 Cad |
| 32 | 192757 | Rod Tie Wire Form |
| 34 | 10040500 | Washer Lock Hvy Hlcl Spr. 5/16 |
| 36 | 155099 | Bushing Strg |
| 37 | 152927 | Screw |
| 38 | 186781 | Insert Cap Strg Wh Au |
| 39 | 19113812 | Washer 11/32 x 2-3/8 OD x 12 Ga. |
| 40 | 73540600 | Nut Crownlock 3/8-24 |
| 41 | 186737 | Adaptor Wheel Strg |
| 42 | 145054X428 | Boot Steering Shaft |
| 43 | 121749X | Washer 25/32 x 1 1/4 x 16 Ga. |
| 44 | 190752 | Extension Steering Shaft |
| 46 | 121232X | Cap Spindle Fr Top Red |
| 65 | 160367 | Spacer Brace Axle |
| 67 | 72110618 | Bolt Rdhd Sq 3/8-16 x 2-1/4 |
| 68 | 169827 | Axle, Brace |
| 71 | 175146 | Steering Asm |
| 82 | 199978 | Bracket |
| 88 | 175118 | Bolt Shoulder 7/16-20 unc |
| 91 | 175553 | Clip Steering |
| 95 | 188967 | Washer Harden .793 x 1.637 x .060 |
| 97 | 74780564 | Bolt 5/16-18 unc x 4" L Gr. 5 |

NOTE: All component dimensions given in U.S. inches
1 inch = 25.4 mm

REPAIR PARTS

TRACTOR - - MODEL NUMBER 944.605931

SEAT ASSEMBLY

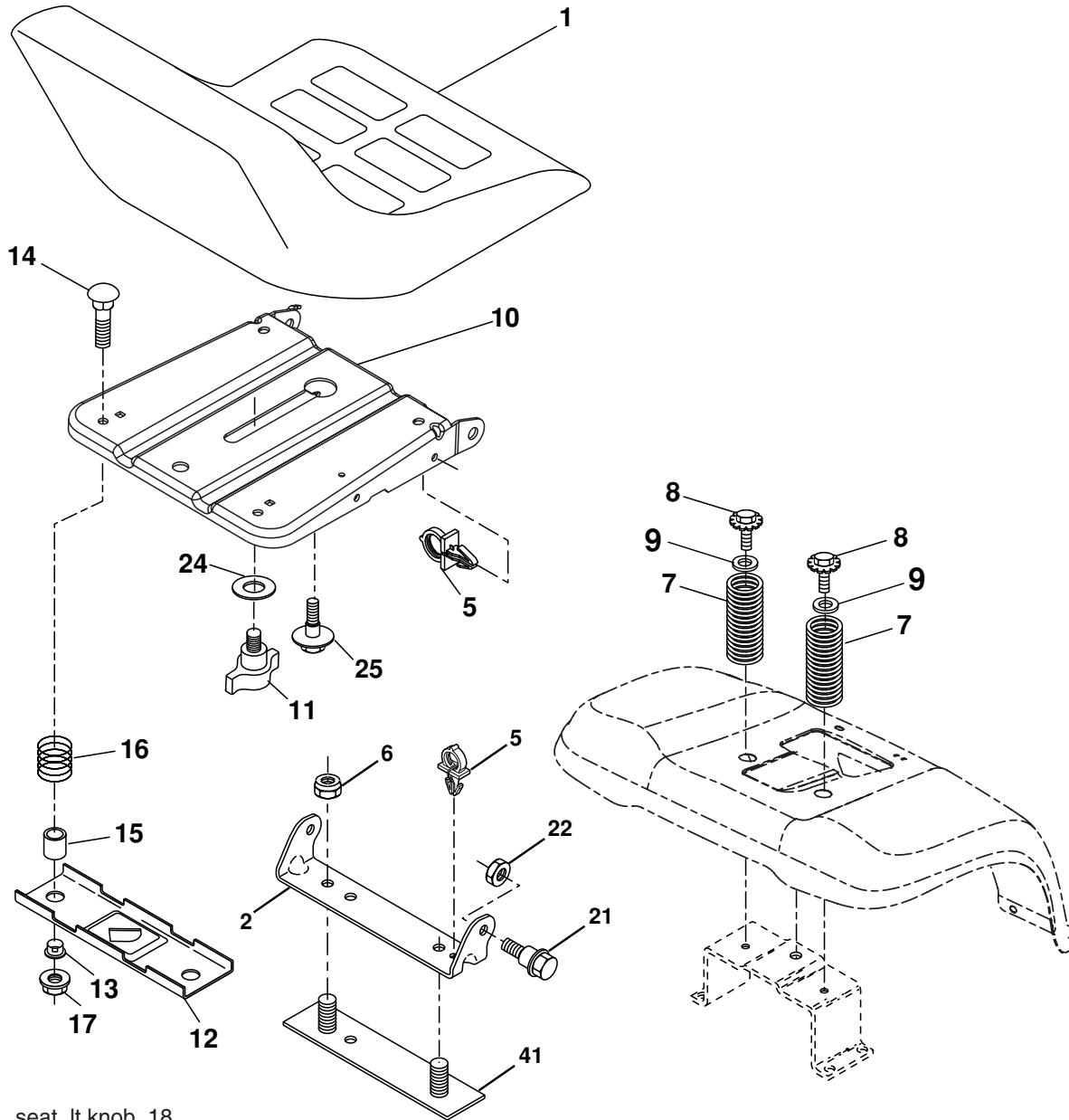

seat_lt.knob_18

| KEY NO. | PART NO. | DESCRIPTION |
|---------|---------------|--------------------------------|
| 1 | 188939 | Seat |
| 2 | 140551 | Bracket Pivot Seat |
| 5 | 145006 | Clip Push-In |
| 6 | STD541437 | Nut Hex w/Ins. 3/8-16 unc |
| 7 | 124181X | Spring Seat Cprsn 2 250 Blk Zi |
| 8 | 17000616 | Screw 3/8-16 x 1.5 |
| 9 | 19131614 | Washer 13/32 x 1 x 14 Ga. |
| 10 | 195530 | Pan Seat |
| 11 | 166369 | Knob Seat |
| 12 | 174648 | Bracket Mounting Switch |
| 13 | 121248X | Bushing Snap Blk Nyl 50 Id |

| KEY NO. | PART NO. | DESCRIPTION |
|---------|----------------|---------------------------------|
| 14 | 72050412 | Bolt Rdhd Sqnk 1/4-20 x 1-1/2 |
| 15 | 134300 | Spacer Split 28x 96 Yel Zinc |
| 16 | 121250X | Spring Cprsn 1 27 Blk Pnt |
| 17 | 123976X | Nut Lock 1/4 Lge Flg Gr. 5 Zinc |
| 21 | 171852 | Bolt Shoulder 5/16-18 unc |
| 22 | STD541431 | Nut Hex Lock W/Ins 5/16-18 |
| 24 | 19171912 | Washer 17/32 x 1-3/16 x 12 Ga. |
| 25 | 127018X | Bolt Shoulder 5/16-18 x .62 |
| 41 | 140675 | Strap Asm. Fender |

NOTE: All component dimensions given in U.S. inches
1 inch = 25.4 mm

REPAIR PARTS

TRACTOR - - MODEL NUMBER 944.605931

DECALS

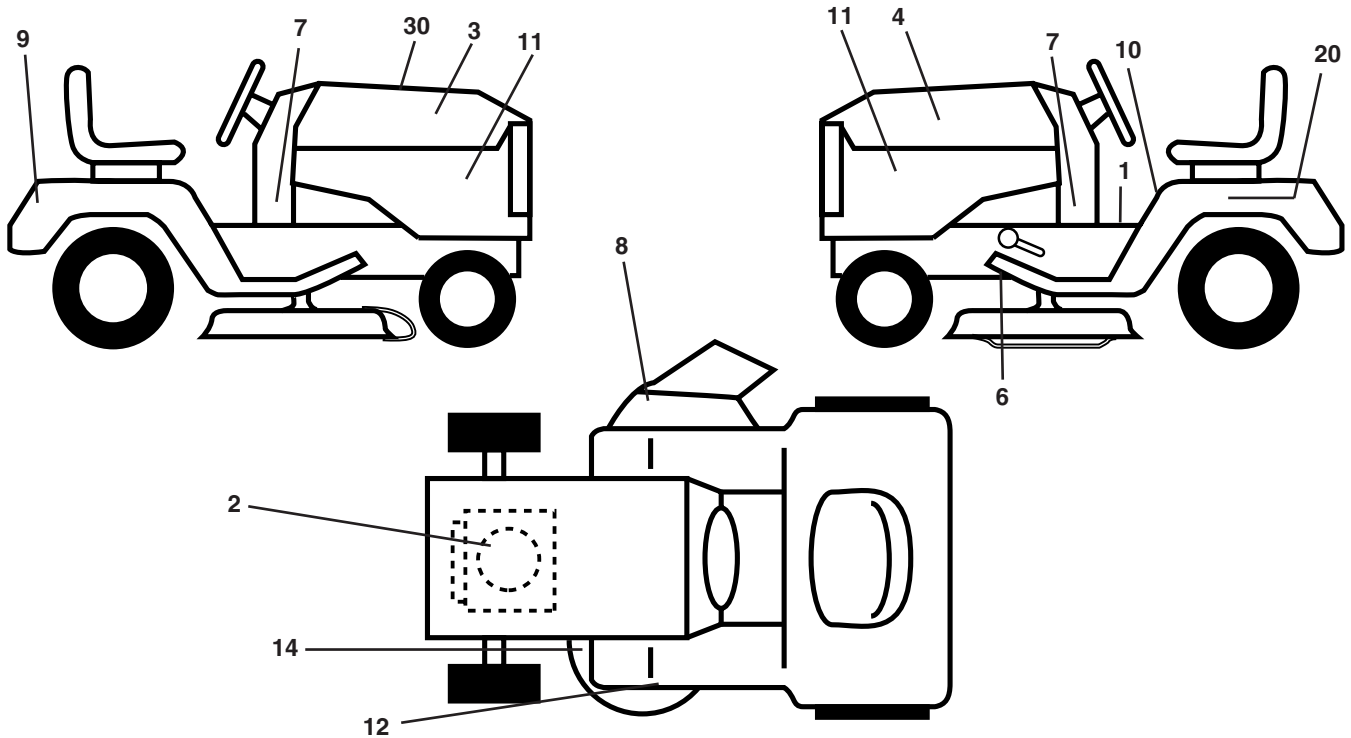

| KEY NO. | PART NO. | DESCRIPTION |
|---------|----------|----------------------------|
| 1 | 193939 | Decal Fend STLT Oper |
| 2 | 189077 | Decal Engine |
| 3 | 186280 | Decal Hood LH |
| 4 | 186281 | Decal Hood RH |
| 6 | 146046 | Decal V Belt Drive Sch |
| 7 | 189086 | Decal Lower Dash |
| 8 | 170563 | Decal Warning |
| 9 | 186282 | Decal Craftsman |
| 10 | 157140 | Decal Fender Danger Eng/Fr |
| 11 | 186283 | Decal Side Panel |

| KEY NO. | PART NO. | DESCRIPTION |
|---------|---------------|--------------------------------|
| 14 | 160396 | Decal V-Belt Schematic |
| 20 | 149517 | Decal Bat Dan/Psn |
| 30 | 199766 | Decal Replacement Parts |
| -- | 184310X428 | Pad Footrest LH STLT |
| -- | 184311X428 | Pad Footrest RH STLT |
| -- | 138311 | Decal Handle Lft Height Adjust |
| -- | 178392 | Decal Chassis Disconnect |
| -- | 199986 | Manual Owner's (English) |
| -- | 199987 | Manual Owner's (French) |

WHEELS & TIRES

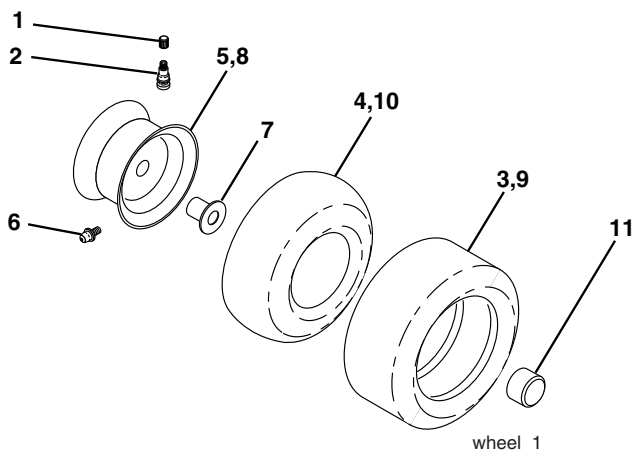

| KEY NO. | PART NO. | DESCRIPTION |
|---------|------------|-----------------------------------|
| 1 | 59192 | Cap Valve Tire |
| 2 | 65139 | Stem Valve |
| 3 | 106222X | Tire F |
| 4 | 59904 | Tube Front (Service Item Only) |
| 5 | 106732X624 | Rim Asm 6" front Service |
| 6 | 278H | Fitting Grease (Front Wheel Only) |
| 7 | 9040H | Bearing Flange (Front Wheel Only) |
| 8 | 106108X624 | Rim Asm 8" rear Service |
| 9 | 138468 | Tire R |
| 10 | 7152J | Tube Rear (Service Item Only) |
| 11 | 104757X428 | Cap Axle Blk 1 50 x 1 00 |
| -- | 144334 | Sealant, Tire (10 oz. Tube) |

NOTE: All component dimensions given in U.S. inches
1 inch = 25.4 mm

REPAIR PARTS

TRACTOR - - MODEL NUMBER 944.605931

ENGINE

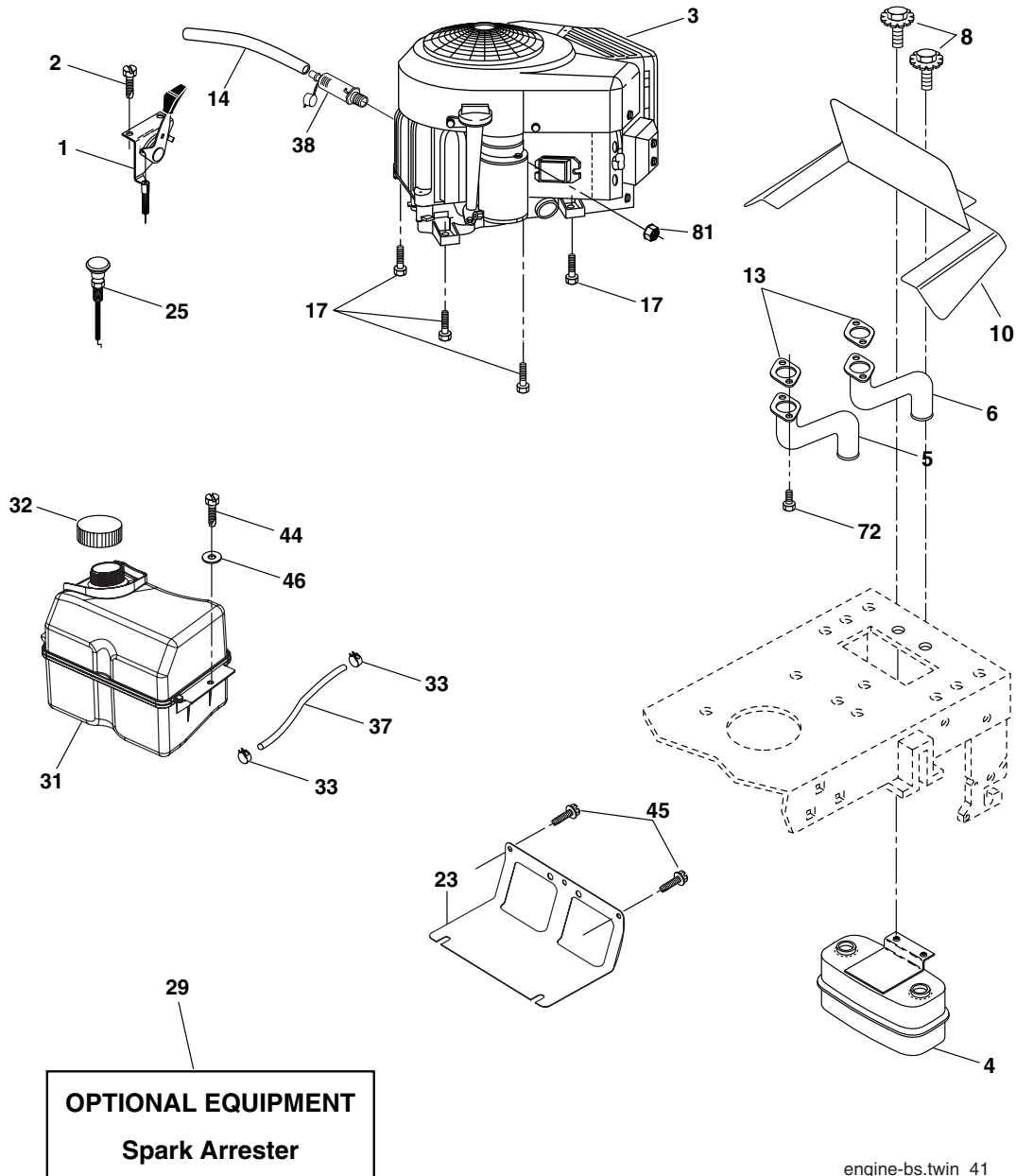

engine-bs.twin_41

| KEY NO. | PART NO. | DESCRIPTION |
|---------|------------|--------------------------------|
| 1 | 170546 | Control Throttle |
| 2 | 17720408 | Screw Hex Thd Cut 1/4-20 x 1/2 |
| 3 | ----- | Engine (See Breakdown) |
| 4 | 149723 | Muffler Exhaust |
| 5 | 159955 | Exhaust Tube LH |
| 6 | 160589 | Exhaust Tube RH |
| 8 | 171877 | Bolt 5/16-18 unc x 3/4 Sems |
| 10 | 162797 | Shield Browning |
| 13 | 165391 | Gasket |
| 14 | 148456 | Tube Drain Oil Easy |
| 17 | 17060624 | Screw 3/8-16 x 1-1/2 |
| 23 | 169837 | Shield Browning |
| 25 | 187766X428 | Control Choke |

| KEY NO. | PART NO. | DESCRIPTION |
|---------|-----------------|-----------------------------------|
| 29 | 137180 | Arrestor Spark |
| 31 | 185534 | Tank Fuel |
| 32 | 197725 | Cap Asm Fuel |
| 33 | 123487X | Clamp Hose Blk |
| 37 | 137040 | Line Fuel 20" |
| 38 | 181654 | Plug Drain Oil Easy |
| 44 | 17670412 | Screw 1/4-20 x 3/4 |
| 46 | 19091416 | Washer 9/32 x 7/8 x 16 Ga. |
| 45 | 17000612 | Screw Hex Wsh Thdrol 3/8-16 x 3/4 |
| 72 | 183906 | Screw Socket Head 5/16-18 x 1 |
| 81 | 73510400 | Nut Keps Hex 1/4-20 unc |

NOTE: All component dimensions given in U.S. inches
1 inch = 25.4 mm

REPAIR PARTS

TRACTOR - - MODEL NUMBER 944.605931

MOWER LIFT

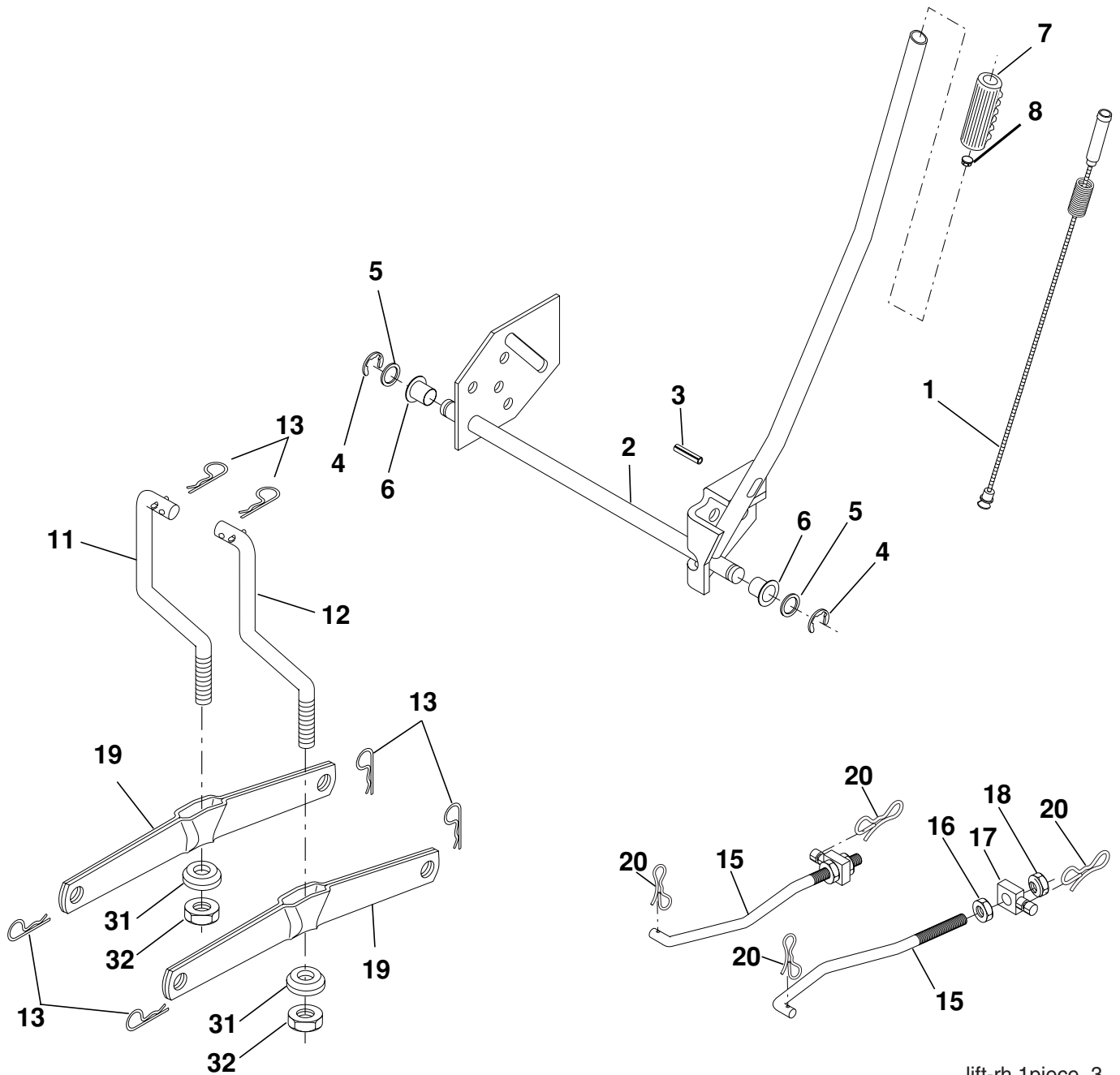

lift-rh.1piece_3

| KEY NO. | PART NO. | DESCRIPTION |
|---------|-----------|-------------------------------|
| 1 | 159460 | Wire Asm Inner W/Plunger |
| 2 | 159471 | Shaft Asm Lift |
| 3 | 105767X | Pin Groove |
| 4 | STD581062 | E Ring |
| 5 | 19211621 | Washer 29/32 x 1-1/4 x 21 Ga. |
| 6 | 120183X | Bearing Nylon Blk .629 ID |
| 7 | 125631X | Grip Handle Fluted |
| 8 | 122365X | Button, Plunger |
| 11 | 139865 | Link Lift Lh Fixed Length |
| 12 | 139866 | Link Lift Rh Fixed Length |

| KEY NO. | PART NO. | DESCRIPTION |
|---------|-----------|------------------------------|
| 13 | STD624008 | Retainer Spring |
| 15 | 173288 | Link Front |
| 16 | 73350800 | Nut Jam Hex 1/2-13 unc |
| 17 | 175689 | Trunnion Blk Zinc |
| 18 | 73800800 | Nut Lock W/Wsh 1/2-13 unc |
| 19 | 139868 | Arm Suspension Rear |
| 20 | 194209 | Pin Cotter 7/16 Bow Tie Lock |
| 31 | 169865 | Bearing Pvt. Lift |
| 32 | 73540600 | Nut Lock 3/8-24 |

NOTE: All component dimensions given in U.S. inches
1 inch = 25.4 mm

REPAIR PARTS

TRACTOR - - MODEL NUMBER 944.605931

MOWER DECK

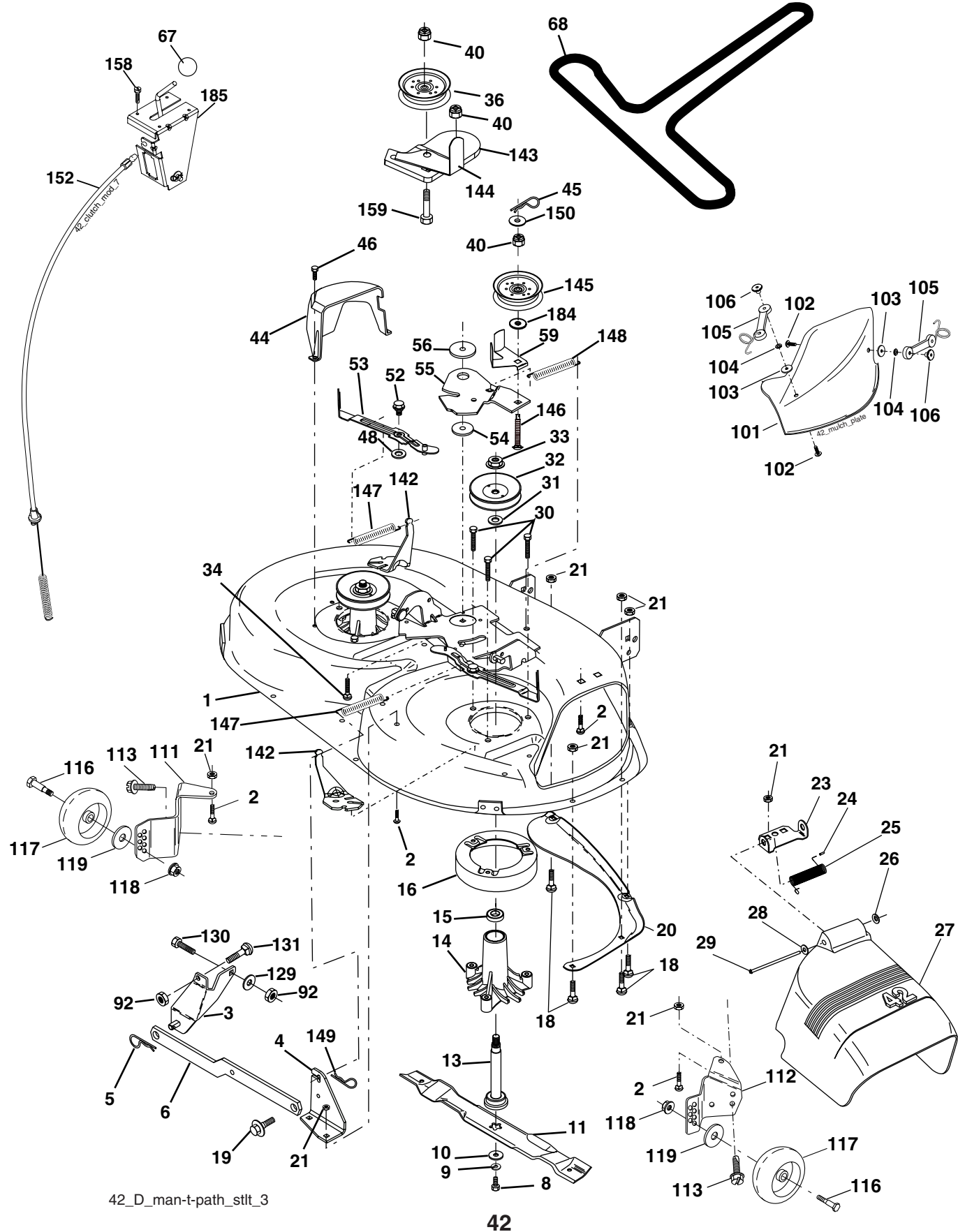

REPAIR PARTS

TRACTOR - - MODEL NUMBER 944.605931

MOWER DECK

| KEY NO. | PART NO. | DESCRIPTION | KEY NO. | PART NO. | DESCRIPTION |
|---------|---------------|--------------------------------------|---------|---------------|---|
| 1 | 165892 | Mower Deck Assembly, 42" | 56 | 165723 | Spacer, Retainer |
| 2 | STD533107 | Bolt | 59 | 141043 | Guard, TUV Idler |
| 3 | 138017 | Bracket Assembly, Sway Bar, Front | 67 | 149846 | Knob Custom Oval |
| 4 | 165460 | Bracket Sway Bar 38/42" Deck | 68 | 144959 | V-Belt |
| 5 | STD624008 | Retainer Spring | 92 | STD541437 | Nut |
| 6 | 178024 | Bar Sway Deck | 101 | 193107 | Mulcher Cover |
| 8 | 850857 | Bolt, Hex 3/8-24 x 1.25 Gr. 8 | 102 | 71081010 | Screw |
| 9 | STD551137 | Washer, Lock | 103 | 19061216 | Washer #10 |
| 10 | 140296 | Washer, Hardened | 104 | STD551110 | Washer, Lock |
| | | (The following blades are available) | 105 | 160793 | Latch Assembly, Bagger |
| 11 | 134149 | Blade, 42" Mulching Std | 106 | 2029J | Nut, Weld |
| | | (For mulching mowers only) | 111 | 179292 | Bracket, Gauge, Wheel L.H. |
| -- | 139775 | Blade, 42" Mulching Premium | 112 | 179293 | Bracket, Gauge, Wheel R.H. |
| | | (For better wear when mulching) | 113 | 17000510 | Bolt Hex Whs. Hd. Lckserr 5/16-18 |
| -- | 138971 | Blade, 42" Hi-Lift | 116 | 4898H | Bolt, Shoulder |
| | | (For bagging or discharging) | 117 | 188606 | Wheel, Gauge |
| 13 | 137645 | Shaft Assembly, Mandrel, Vented | 118 | 73930600 | Nut, Centerlock 3/8-16 |
| 14 | 128774 | Housing, Mandrel, Vented | 119 | STD551037 | Washer 3/8 x 7/8 x 14 Ga. |
| 15 | 110485X | Bearing, Ball, Mandrel | 129 | 19131312 | Washer 13/32 x 13/16 x 12 Ga. |
| 16 | 174493 | Stripper, Vented Mower Deck | 130 | STD523710 | Bolt, Fin Hex 3/8-16 unc x 1 Gr. 5 |
| 18 | 72140505 | Bolt, Carriage 5/16-18 x 5/8 | 131 | STD533710 | Bolt, Rdhd Sqnk 3/8-16 unc x 1 |
| 19 | 132827 | Bolt, Shoulder | 142 | 165890 | Arm Spring Brake Mower |
| 20 | 159770 | Baffle, Vortex | 143 | 157109 | Bracket Arm Idler 42" |
| 21 | STD541431 | Nut Crownlock 5/16-18 unc | 144 | 158634 | Keeper Belt 42" Clutch Cable |
| 23 | 177563 | Bracket, Deflector | 145 | 165888 | Pulley Idler Flat |
| 24 | 105304X | Cap, Sleeve | 146 | 171977 | Bolt Carriage Idler |
| 25 | 123713X | Spring, Torsion, Deflector | 147 | 131335 | Spring Extension |
| 26 | 110452X | Nut, Push | 148 | 169022 | Spring Return Idler |
| 27 | 130968X428 | Shield, Deflector | 149 | 165898 | Retainer Spring Yellow Zinc |
| 28 | 19111016 | Washer 11/32 x 5/8 x 16 Ga. | 150 | 19091210 | Washer 9/32 x 3/4 x 10 Ga. |
| 29 | 131491 | Rod, Hinge | 152 | 169676 | Cable Clutch 42 In |
| 30 | 173984 | Screw Thdrol Washer Head | 158 | 17720408 | Screw Hex Thd Cut 1/4-20 x 5/8 |
| 31 | 187690 | Washer, Spacer | 159 | 72140614 | Bolt Rdhd Sqn 3/8-16 unc x 1-3/4 |
| 32 | 153535 | Pulley, Mandrel | 184 | 19131410 | Washer 13/32 x 7/8 x 10 Ga. |
| 33 | 400234 | Nut, Toplock, Flanged | 185 | 188234 | Head Asm. Cable Clutch |
| 34 | 72110612 | Bolt Carr. Sh. 3/8-16 x 1-1/2 Gr. 5 | -- | 130794 | Mandrel Assembly (Includes Housing, Shaft and Shaft Hardware Only -Pulley Not Included) |
| 36 | 131494 | Pulley, Idler, Flat | -- | 169583 | Replacement Mower Complete (Std. Deck-Order separately mulcher cover and guage wheels components key nos 101 - 106 and 116 - 119) |
| 40 | 73900600 | Nut Lock Flg. 3/8-16 unc | | | |
| 44 | 140088 | Guard, Mandrel, L.H. | | | |
| 45 | STD624003 | Retainer | | | |
| 46 | 137729 | Screw, Thd. Roll 1/4-20 x 5/8 | | | |
| 48 | 133944 | Washer, Hardened | | | |
| 52 | 139888 | Bolt, Shoulder 5/16-18 unc | | | |
| 53 | 184907 | Arm Assembly, Pad, Brake | | | |
| 54 | 178515 | Washer, Hardened | | | |
| 55 | 155046 | Arm, Idler | | | |

NOTE: All component dimensions given in U.S. inches
1 inch = 25.4 mm

REPAIR PARTS

TRACTOR - - MODEL NUMBER 944.605931

PEERLESS TRANSAXLE - MODEL NUMBER LTH2000

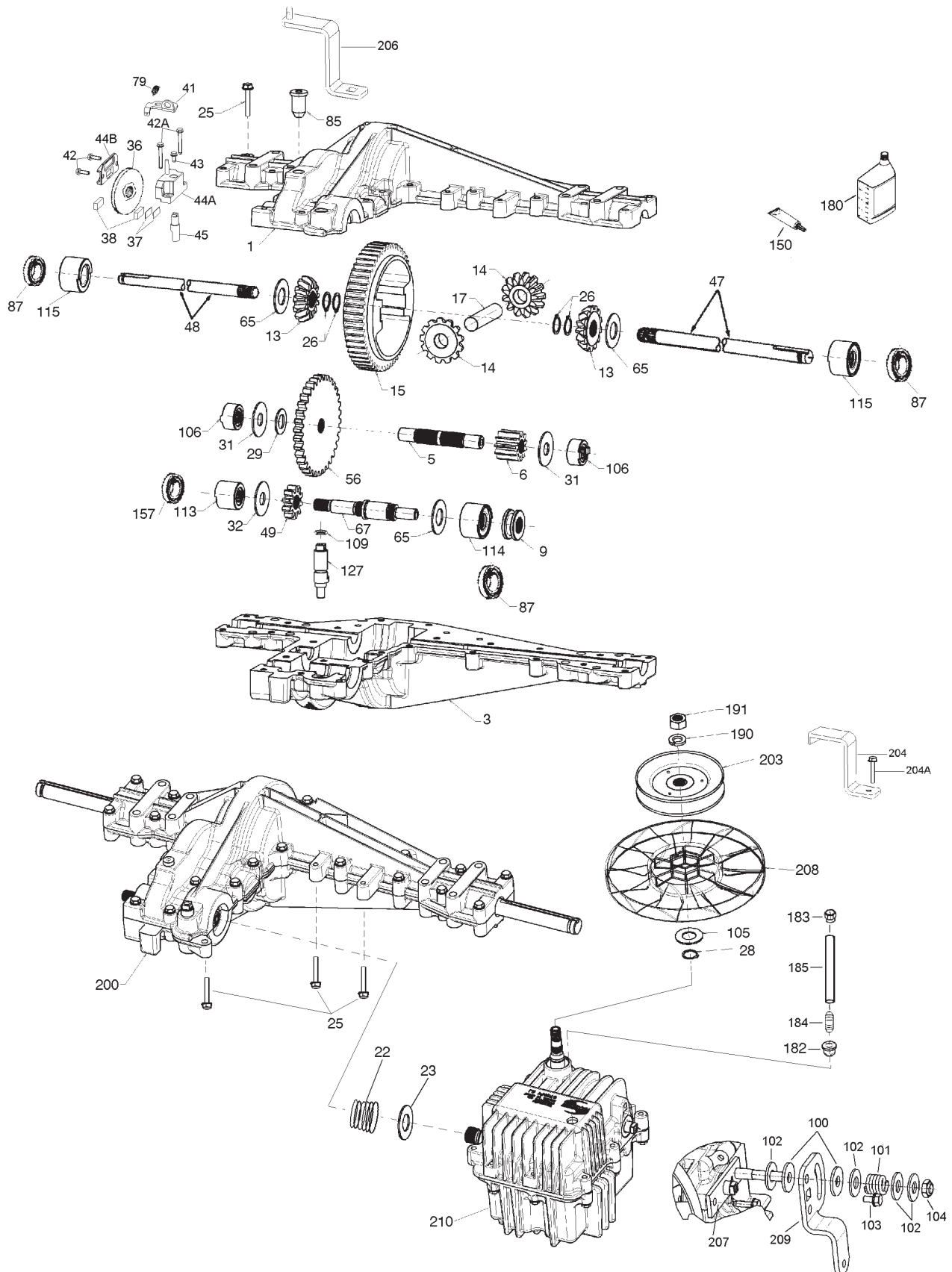

REPAIR PARTS

TRACTOR - - MODEL NUMBER 944.605931

PEERLESS TRANSAXLE - MODEL NUMBER LTH2000

| KEY PART NO. NO. | DESCRIPTION | KEY PART NO. NO. | DESCRIPTION |
|---------------------|-------------|-------------------------------------|-------------|
| 1 | 772151 | Cover L.H. | |
| 3 | 770135 | Case | |
| 5 | 776355 | Counter Shaft | |
| 6 | 778263 | Spur Gear 11T | |
| 9 | 786197 | Neutral Sleeve (.572) | |
| 13 | 778368 | Bevel Gear (Incl. 14) (13 Teeth) | |
| 14 | 778368 | Bevel Gear (Incl. 13) (13 Teeth) | |
| 15 | 778373 | Ring Gear (54 Teeth) | |
| 17 | 786139 | Drive Pin | |
| 22 | 792194 | Spring | |
| 23 | 792195 | Washer .750 ID | |
| 25 | 792073A | Screw 1/4-20 x 1-1/4" | |
| 26 | 792125 | Retaining Ring | |
| 28 | 792035 | Retaining Ring | |
| 29 | 780065 | Washer .627 ID .091W | |
| 31 | 780189 | Washer .563 ID .062W | |
| 36 | 790071 | Brake Disk | |
| 37 | 790007 | Brake Pad Plate | |
| 38 | 799021 | Brake Pad | |
| 40 | 792204 | Roll Pin .25 | |
| 41 | 790102 | Brake Lever | |
| 42 | 792202 | Screw, 1/4-20 x 3/4 | |
| 42A | 792203 | Screw, 1/4-20 x 1-3/4 | |
| 43 | 792171 | Screw, 10-24 x .500 | |
| 44A | 790100 | Inside Brake (Mach) | |
| 44B | 790099 | Outside Brake (Casting) | |
| 45 | 790101 | Actuator Rod | |
| 47 | 774869 | Axle 16.812 | |
| 48 | 774688 | Axle 11.625 | |
| 49 | 778378 | Spur Gear 18T | |
| 56 | 778379 | Spur Gear 81T | |
| 65 | 780195 | Washer .750ID .062W | |
| 67 | 776440 | Brakeshaft | |
| 70 | 786196 | Spacer .625 .765 | |
| 79 | 792201 | Spring | |
| 85 | 792154 | Oil Fill Plug | |
| 87 | 788088A | Oil Seal 3/4" | |
| 99 | 792141 | Washer .377ID .058W | |
| 100 | 792200 | Snubber Washer | |
| 101 | 792199 | Snubber Spring .47ID | |
| 102 | 792184 | Washer .437ID .078W | |
| 103 | 792193 | Screw, 1/4-28 x .490 | |
| 104 | 792198 | Nut, 3/8-24 | |
| 105 | 780096 | Washer .625 ID .057W | |
| 106 | 786162 | Sleeve Assembly | |
| 107 | 792046 | Screw, 1/4-20 x 1" | |
| 109 | 788104 | "O" Ring | |
| 113 | 786199 | Sleeve Ass'y (Incl. 157) | |
| 114 | 786200 | Sleeve Ass'y (Incl. 87) | |
| 115 | 786198 | Sleeve Assembly (Incl. 87) | |
| 127 | 784384 | Shift Lever Ass'y (Incl. 109) | |
| 150 | 788093A | Liquid Gasket RTV Silicon | |
| 157 | 788102 | Oil Seal 9/16"ID | |
| 180 | 730229 | BOil Spec. (80W90) | |
| 182 | 788103 | Grommet | |
| 183 | 792118 | Relief Valve | |
| 184 | 792196 | Hose Barb | |
| 185 | 798050 | Tubing 1/2 x 5 | |
| 190 | 792150 | Washer | |
| 191 | 792151 | Nut 7/16-20 | |
| 200 | 794787 | Differential (Gear Reduction Drive) | |
| 203 | 798044 | Pulley & Hub Ass'y | |
| 206 | 798055 | Disconnect Lever | |
| 207 | 798053 | Mounting Plate | |
| 208 | 798040 | Fan | |
| 209 | 798054 | Control Lever | |
| 210 | 794788 | Hydro Module LH Fender Control | |

REPAIR PARTS

TRACTOR - - MODEL NUMBER 944.605931

BRIGGS & STRATTON ENGINE - MODEL NUMBER 445577, TYPE NUMBER 0485-E1

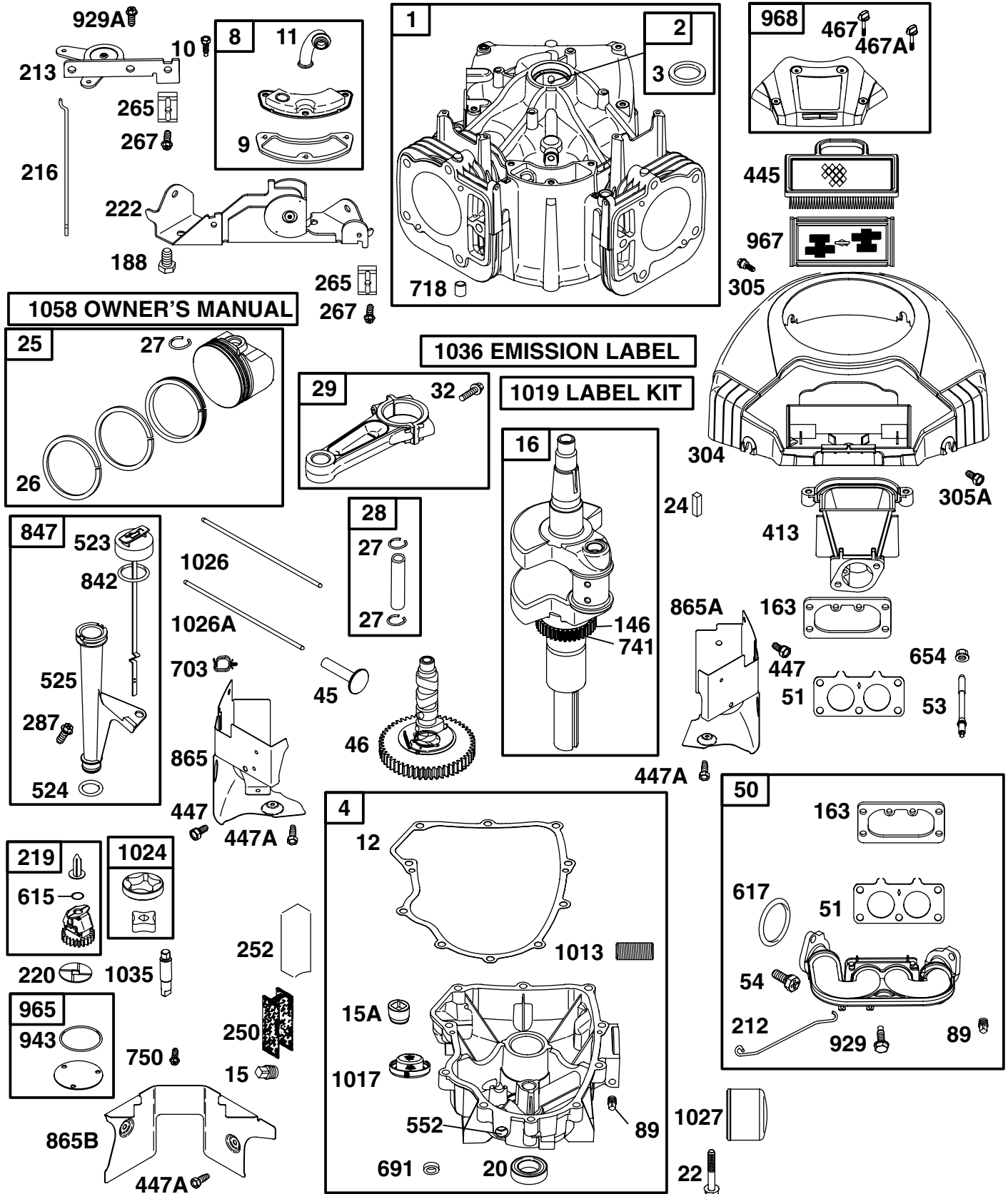

REPAIR PARTS

TRACTOR - - MODEL NUMBER 944.605931

BRIGGS & STRATTON ENGINE - MODEL NUMBER 445577, TYPE NUMBER 0485-E1

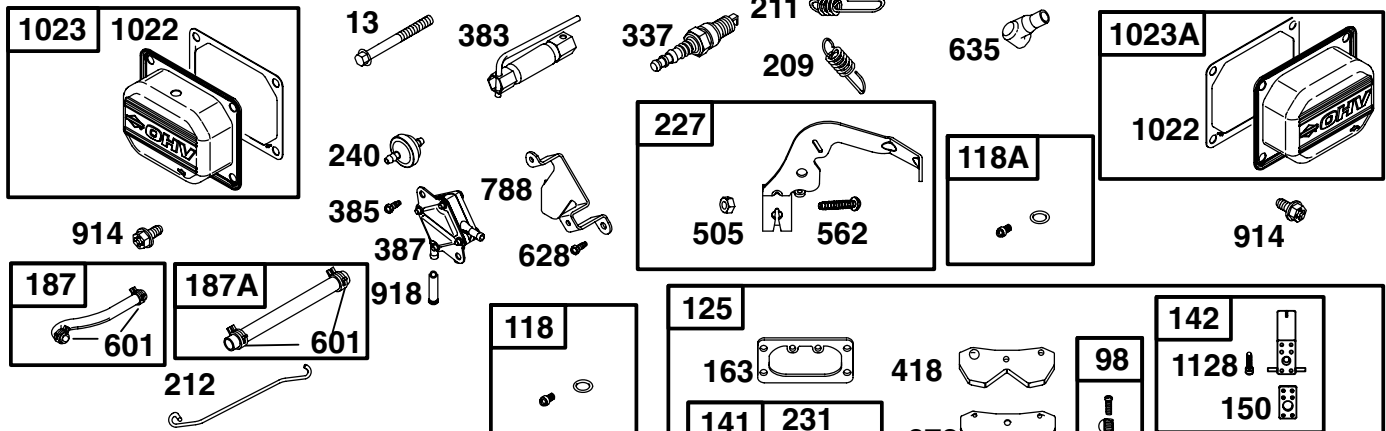
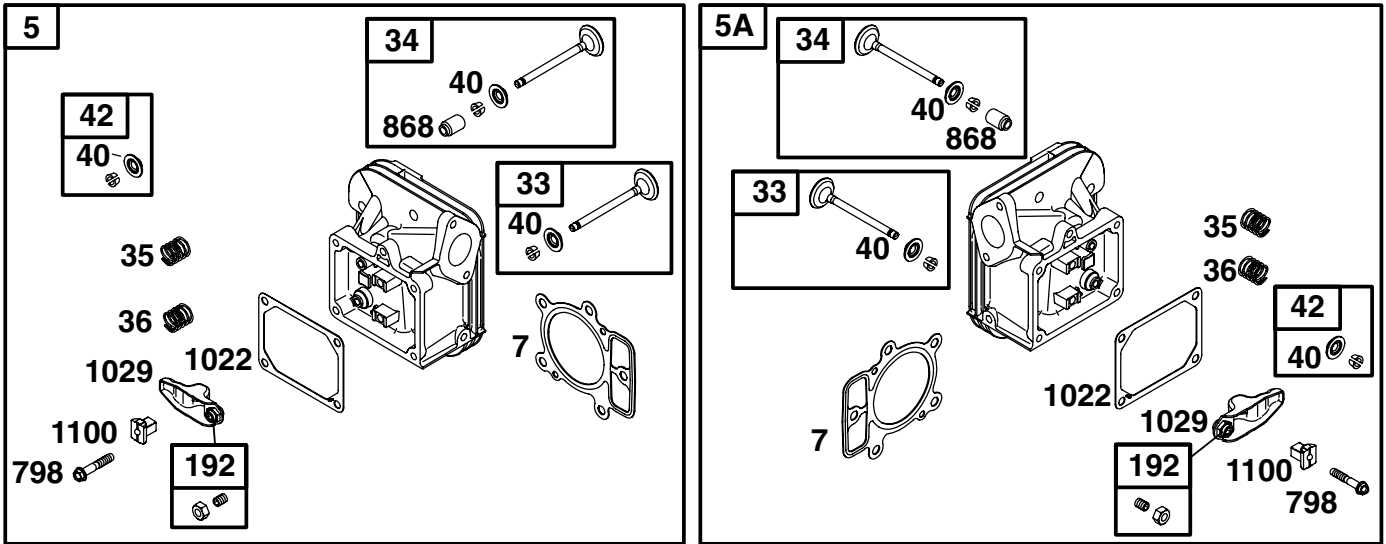

121 CARBURETOR OVERHAUL KIT

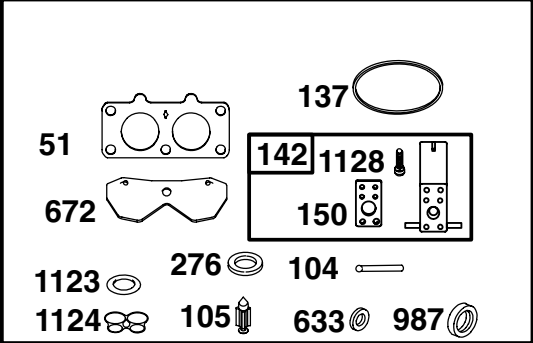

977 CARBURETOR GASKET SET

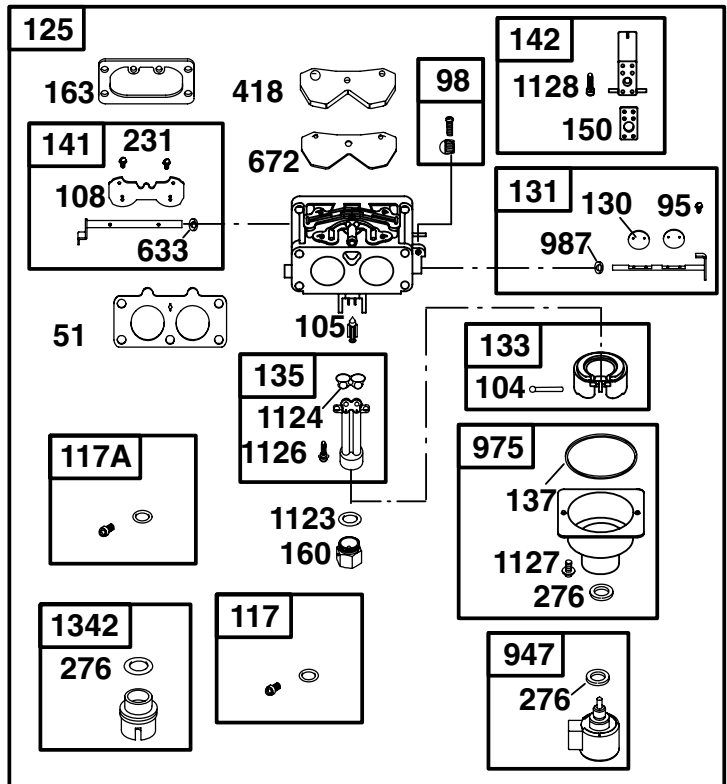
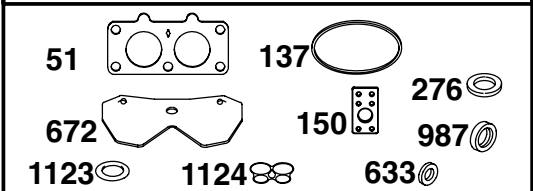

REPAIR PARTS

TRACTOR - - MODEL NUMBER 944.605931

BRIGGS & STRATTON ENGINE - MODEL NUMBER 445577, TYPE NUMBER 0485-E1

1329 REPLACEMENT ENGINE

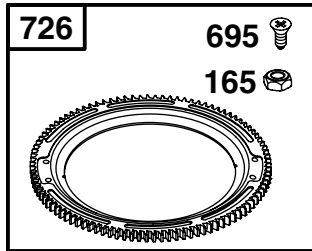
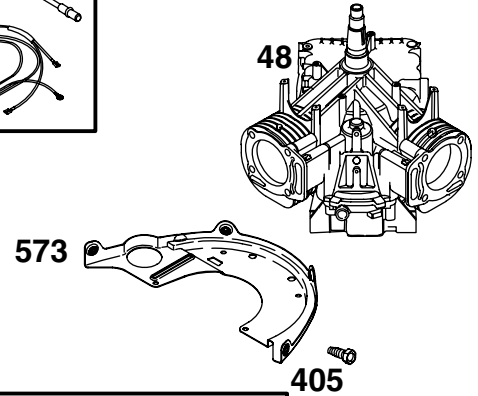
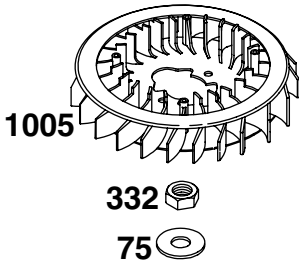
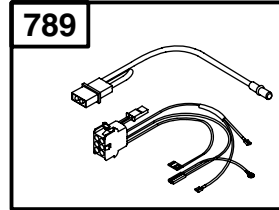
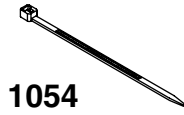
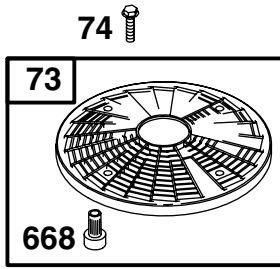

1330 REPAIR MANUAL

1095 VALVE GASKET SET

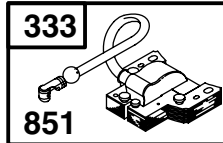
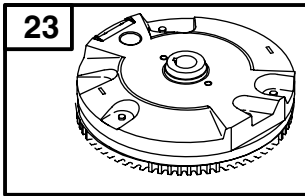
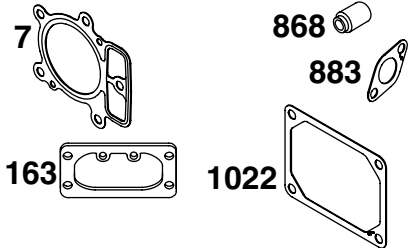

358 ENGINE GASKET SET

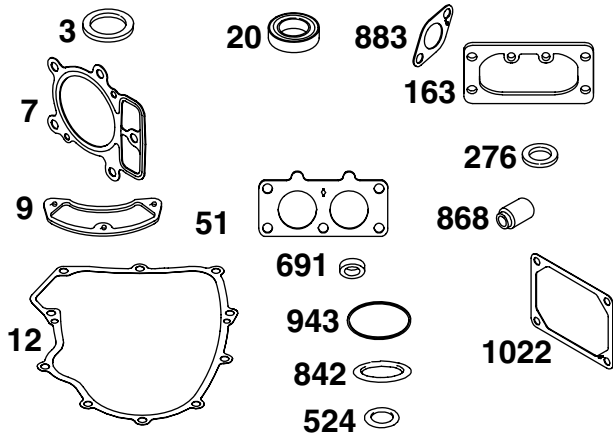

309

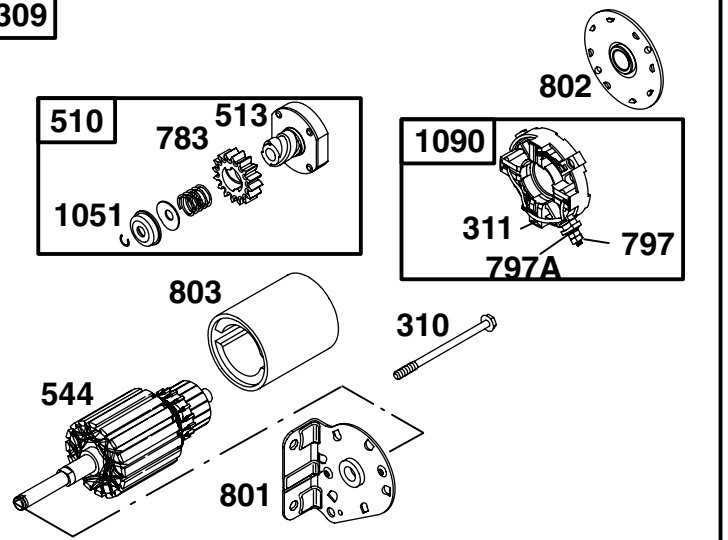

REPAIR PARTS

TRACTOR - - MODEL NUMBER 944.605931

BRIGGS & STRATTON ENGINE - MODEL NUMBER 445577, TYPE NUMBER 0485-E1

| KEY NO. | PART NO. | DESCRIPTION | KEY NO. | PART NO. | DESCRIPTION |
|---------|----------|----------------------------------|---------|----------|---|
| 1 | 699753 | Cylinder Assembly | 121 | 699734 | Kit-Carburetor Overhaul |
| 2 | 499585 | Kit-Bushing/Seal (Magneto Side) | 125 | 699709 | Carburetor |
| 3 | 391086 | • Seal-Oil (Magneto Side) | 130 | 690993 | Valve-Throttle |
| 4 | 699747 | Sump-Engine | 131 | 499805 | Kit-Throttle Shaft |
| 5 | 693998 | Head-Cylinder (Cylinder 1) | 133 | 699724 | Float-Carburetor |
| 5A | 693999 | Head-Cylinder (Cylinder 2) | 135 | 699729 | Tube-Fuel Transfer |
| 7 | 693997 | •+ Gasket-Cylinder Head | 137 | 690994 | ∅‡ Gasket-Float Bowl |
| 8 | 499601 | Breather Assembly | 141 | 699722 | Kit-Choke Shaft |
| 9 | 690937 | • Gasket-Breather | 142 | 699726 | ∅ Nozzle-Carburetor |
| 10 | 691108 | Screw (Breather Assembly) | 146 | 690979 | Key-Timing |
| 11 | 690942 | Tube-Breather | 150 | 690995 | ∅‡ Gasket-Nozzle |
| 12 | 697227 | • Gasket-Crankcase | 160 | 699727 | Retainer-Solenoid |
| 13 | 791130 | Screw (Cylinder Head) | 163 | 691001 | •+ Gasket-Air Cleaner |
| 15 | 690946 | Plug-Oil Drain | 165 | 693148 | Nut (Ring Gear) |
| 15A | 691680 | Plug-Oil Drain | 187 | 691049 | Line-Fuel |
| 16 | 790136 | Crankshaft | 187A | 691050 | Line-Fuel (Cut to Required Length) |
| 20 | 690947 | • Seal-Oil (PTO Side) | 188 | 691108 | Screw (Control Bracket) |
| 22 | 694966 | Screw (Crankcase Cover) | 192 | 690083 | Adjuster-Rocker Arm |
| 23 | 691054 | Flywheel | 209 | 697674 | Spring-Governor |
| 24 | 222698 | Key-Flywheel | 211 | 691019 | Spring-Governed Idle |
| 25 | 694003 | Piston Assembly (Standard) | 212 | 695238 | Link-Governor |
| | 694007 | Piston Assembly (.020" Oversize) | 213 | 691021 | Bracket-Choke Control |
| 26 | 694004 | Ring Set (Standard) | 216 | 691022 | Link-Choke |
| | 694008 | Ring Set (.020" Oversize) | 219 | 698231 | Gear-Governor |
| 27 | 690975 | Lock-Piston Pin | 220 | 690412 | Washer (Governor Gear) |
| 28 | 690229 | Pin-Piston (Standard) | 222 | 698761 | Bracket-Control |
| 29 | 699699 | Rod-Connecting (Standard) | 227 | 691048 | Lever-Governor Control |
| 32 | 690976 | Screw (Connecting Rod) | 231 | 690718 | Screw (Choke Valve) |
| 33 | 499596 | Valve-Exhaust | 240 | 691035 | Filter-Fuel |
| 34 | 697464 | Valve-Intake | 250 | 690957 | Retainer-Breather |
| 35 | 690963 | Spring-Valve (Intake) | 252 | 690956 | Collector-Oil |
| 36 | 690963 | Spring-Valve (Exhaust) | 265 | 691024 | Clamp-Casing |
| 42 | 499586 | Keeper-Valve | 267 | 695134 | Screw (Casing Clamp) |
| 45 | 690977 | Tappet-Valve | 276 | 690997 | •∅‡ Washer-Sealing |
| 46 | 790562 | Camshaft | 287 | 691108 | Screw (Dipstick/Tube Assembly) |
| 48 | 698172 | Short Block | 304 | 790688 | Housing-Blower |
| 50 | 695241 | Manifold-Intake | 305 | 691005 | Screw (Blower Housing) |
| 51 | 690950 | •∅‡ Gasket-Intake | 305A | 790690 | Screw (Blower Housing) |
| 53 | 690951 | Stud (Carburetor) | 309 | 691262 | Motor-Starter |
| 54 | 699816 | Screw (Intake Manifold) | 310 | 691263 | Screw (Starter Motor) |
| 73 | 494439 | Screen-Rotating | 311 | 497608 | Brush Set |
| 74 | 698425 | Screw (Rotating Screen) | 332 | 691059 | Nut (Flywheel) |
| 75 | 691056 | Washer (Flywheel) | 333 | 691060 | Armature-Magneto |
| 89 | 690283 | Plug-Oil | 334 | 691061 | Screw (Magneto Armature) |
| 95 | 690718 | Screw (Throttle Valve) | 337 | 491055 | Spark Plug |
| 98 | 699721 | Kit-Idle Speed | | | |
| 104 | 694918 | ∅ Pin-Float Hinge | | | • Included in Engine Gasket Set, Key. No. 358 |
| 105 | 698537 | ∅ Valve-Float Needle | | | ∅ Included in Carburetor Overhaul Kit, Key. No. 121 |
| 108 | 699723 | Valve-Choke | | | ‡ Included in Carburetor Gasket Set, Key. No. 977 |
| 117 | 699732 | Jet-Main (Standard) | | | + Included in Valve Overhaul Kit, Key. No. 1095 |
| 117A | 699733 | Jet-Main (Standard) | | | |
| 118 | 699458 | Jet-Main (High Altitude, Right) | | | |
| 118A | 790890 | Jet-Main (High Altitude, Left) | | | |

NOTE: All component dimensions given in U.S. inches 1 inch = 25.4 mm

REPAIR PARTS

TRACTOR - - MODEL NUMBER 944.605931

BRIGGS & STRATTON ENGINE - MODEL NUMBER 445577, TYPE NUMBER 0485-E1

| KEY NO. | PART NO. | DESCRIPTION | KEY NO. | PART NO. | DESCRIPTION |
|---------|----------|--|---------|-------------|---|
| 358 | 694012 | Gasket Set-Engine | 865A | 691014 | Cover-Air Guide (Cylinder 2) |
| 363 | 19374 | Puller-Flywheel | 865B | 691015 | Cover-Air Guide |
| 383 | 89838 | Wrench-Spark Plug | 868 | 690968 | •+ Seal-Valve |
| 385 | 691108 | Screw (Fuel Pump) | 877 | 399916 | Wire/Connector-Alternator |
| 387 | 808656 | Pump-Fuel | 914 | 691127 | Screw (Rocker Arm Cover) |
| 404 | 690442 | Washer (Governor Crank) | 918 | 694000 | Hose-Vacuum |
| 405 | 697820 | Screw (Back Plate) | 929 | 695239 | Screw (Choke Control Bracket) |
| 418 | 690999 | Plate-Carburetor | 929A | 691003 | Screw (Choke Control Bracket) |
| 431 | 790816 | Elbow-Intake | 943 | 690589 | • Seal-O Ring (Oil Pump Cover) |
| 445 | 499486 | Filter-Air Cleaner Cartridge | 947 | 699728 | Solenoid-Fuel |
| 447 | 691003 | Screw (Air Guide Cover) | 965 | 499613 | Cover-Oil Pump |
| 447A | 691108 | Screw (Air Guide Cover) | 967 | 273638 | Filter-Pre Cleaner |
| 467 | 691008 | Knob-Air Cleaner | 968 | 790689 | Cover-Air Cleaner |
| 467A | 790697 | Knob-Air Cleaner | 975 | 499810 | Bowl-Float |
| 474 | 696459 | Alternator | 977 | 699735 | Gasket Set-Carburetor |
| 505 | 691029 | Nut (Governor Control Lever) | 987 | 691000 | Ø‡ Seal-Throttle Shaft |
| 510 | 497606 | Drive-Starter | 1005 | 790698 | Fan-Flywheel |
| 513 | 692024 | Clutch-Drive | 1013 | 690954 | Nipple-Oil Filter |
| 523 | 691036 | Dipstick | 1017 | 690770 | Screen-Oil Pump |
| 524 | 691032 | • Seal-O Ring (Dipstick Tube) | 1019 | 693995 | Kit-Label |
| 525 | 691037 | Tube-Dipstick | 1022 | 690971 | •+ Gasket-Rocker Cover |
| 544 | | Armature-Starter (Serviced by 691262 Starter Motor Only) | 1023 | 499599 | Cover-Rocker Arm (Cylinder 1) |
| | | | 1023A | 499600 | Cover-Rocker Arm (Cylinder 2) |
| 552 | 690552 | Bushing-Governor Crank | 1024 | 499054 | Pump-Oil |
| 552A | 690553 | Bushing-Governor Crank | 1026 | 690981 | Rod-Push (Steel) |
| 562 | 690311 | Bolt (Governor Control Lever) | 1026A | 690982 | Rod-Push (Aluminum) |
| 573 | 691009 | Plate-Back | 1027 | 492932 | Filter-Oil |
| 601 | 691038 | Clamp-Hose | 1029 | 690972 | Arm-Rocker |
| 615 | 698290 | Retainer-Governor Shaft | 1035 | 691042 | Shaft-Pump |
| 616 | 691045 | Crank-Governor | 1036 | 790626 | Label-Emission |
| 617 | 691917 | Seal-O Ring (Intake Manifold) | 1051 | 691265 | Ring-Retaining |
| 628 | 691108 | Screw (Fuel Pump Bracket) | 1058 | 275475 | Owner's Manual |
| 633 | 690998 | Ø‡ Seal-Choke/Throttle Shaft | 1090 | 691293 | Retainer-Brush |
| 635 | 66538 | Boot-Spark Plug | 1095 | 694013 | Set-Valve Gasket |
| 654 | 690958 | Nut (Carburetor) | 1100 | 690973 | Pivot-Rocker Arm |
| 668 | 691215 | Spacer | 1119 | 691183 | Screw (Alternator) |
| 672 | 690234 | Ø‡ Gasket-Carburetor Plate | 1123 | 699725 | Ø‡ Seal-O Ring (Solenoid Retainer) |
| 691 | 690657 | • Seal-Governor Shaft | 1124 | 690988 | Ø‡ Seal-O Ring (Fuel Transfer Tube) |
| 695 | 693149 | Screw (Ring Gear) | 1126 | 690991 | Screw (Fuel Transfer Tube) |
| 697 | 690372 | Screw (Drive Cap) | 1127 | 690992 | Screw (Float Bowl) |
| 703 | 691010 | Clip | 1128 | 690990 | Ø Screw (Carburetor Nozzle) |
| 718 | 690959 | Pin-Locating | 1329 | 446777-0127 | Replacement Engine (Transfer muffler and/or spark arrestor assembly from the original engine if suitable for additional service or add new parts as required) |
| 726 | 499612 | Gear-Ring | | | |
| 741 | 690980 | Gear-Timing | | | |
| 742 | 690328 | Retainer-E Ring | | | |
| 750 | 696999 | Screw (Oil Pump Cover) | | | |
| 783 | 693058 | Gear-Pinion | | | |
| 788 | 691039 | Bracket-Fuel Pump | 1330 | 273521 | Repair Manual |
| 789 | 698330 | Harness-Wiring | 1342 | 699731 | Extension Fuel Transfer Tube |
| 797 | 691029 | Nut (Brush Retainer) | | | |
| 797A | 693167 | Nut (Brush Retainer) | | | |
| 798 | 697890 | Screw (Rocker Arm) | | | |
| 801 | 691283 | Cap-Drive | | | |
| 802 | 691286 | Cap-End | | | |
| 803 | | Housing-Starter (Serviced by 691262 Starter Motor Only) | | | |
| | | | | | |
| 842 | 691031 | • Seal-O Ring (Dipstick) | | | |
| 847 | 499602 | Assembly-Dipstick/Tube | | | |
| 851 | 493880 | Terminal-Spark Plug | | | |
| 865 | 691012 | Cover-Air Guide (Cylinder 1) | | | |

NOTE: All component dimensions given in U.S. inches 1 inch = 25.4 mm

SUGGESTED GUIDE FOR SIGHTING SLOPES FOR SAFE OPERATION

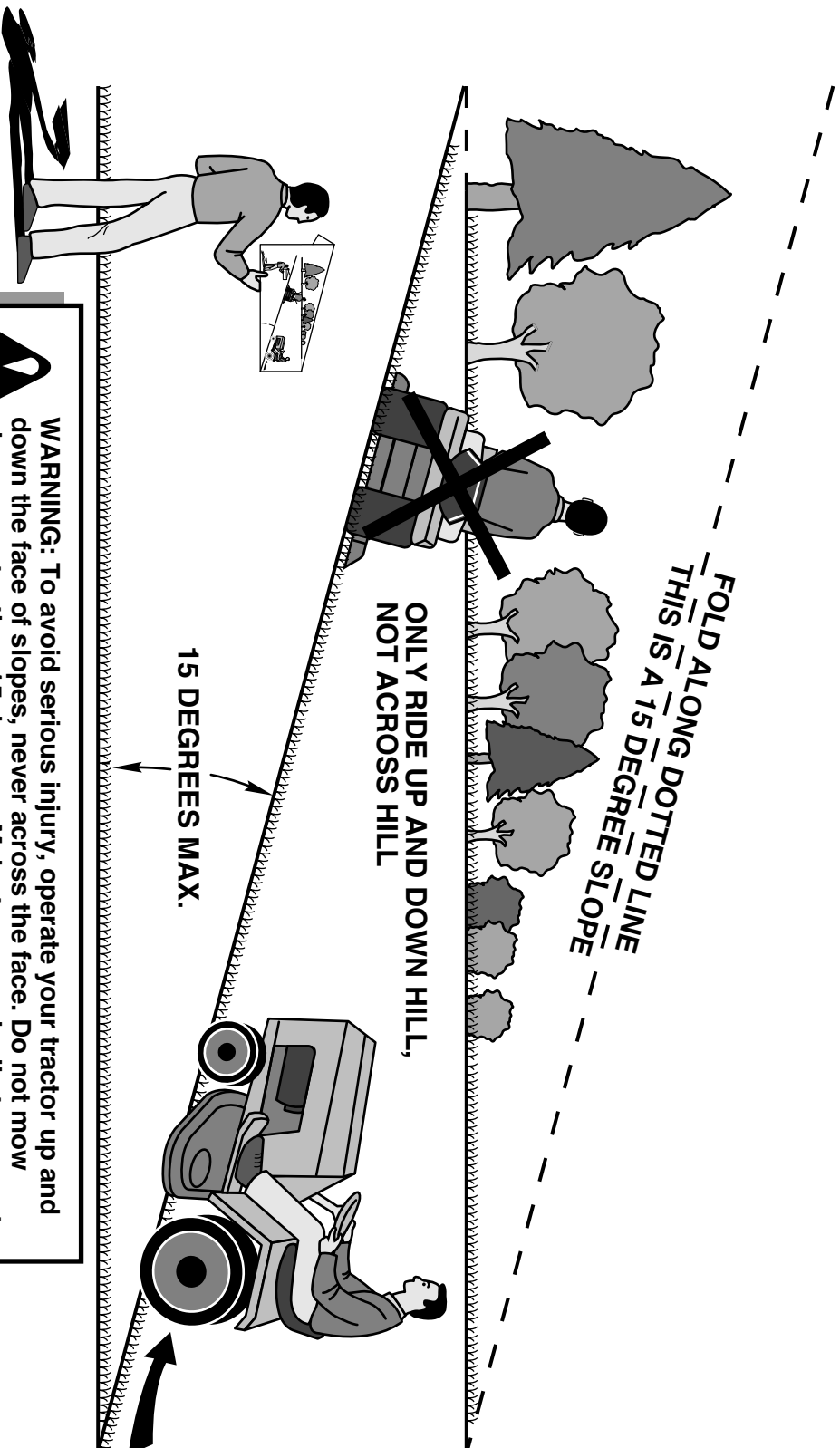

1. Fold this page along dotted line indicated above.
2. Hold page before you so that its left edge is vertically parallel to a tree trunk or other upright structure.
3. Sight across the fold in the direction of hill slope you want to measure.
4. Compare the angle of the fold with the slope of the hill.

Get it fixed, at your home or ours!

Just Call:

1-800-4-MY-HOME[®]

(1-800-469-4663)

24 hours a day, 7 days a week

For the repair of major brand appliances **in your own home...**
no matter who made it, no matter who sold it!

For your nearest **Sears Parts and Service** location,
to bring in products like vacuums, lawn equipment and electronics.

For **Sears Parts & Service**, to order the replacement parts,
accessories and owner's manuals that you need to do-it-yourself.

www.sears.ca

To purchase or inquire about a Sears Maintenance Agreement, call:

1-800-361-6665

9 a.m. – 11 p.m. Mon. – Fri., EST, 9 a.m. – 4 p.m. Sat.

Pour service en français:

1-800-LE-FOYER^{MC}

(1-800-533-6937)

www.sears.ca



02488e

[®] / [™] Trademarks of Sears, Roebuck and Co. used under license by Sears Canada

^{MD} Marque déposée / ^{MC} Marque de commerce de Sears, Roebuck and Co. utilisée en vertu d'une licence de Sears Canada