

**SEARS**  
OWNER'S  
MANUAL

**MODEL NO.**  
**944.606092**

**Important:**  
Read and follow  
all Safety Rules  
and Instructions  
Before Operating  
This Equipment

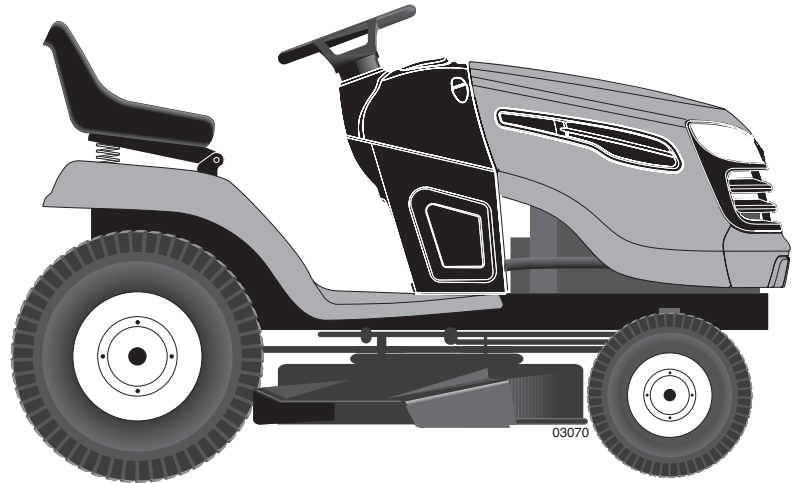

**CRAFTSMAN®**

**27.0 HP**  
**ELECTRIC START**  
**54" MOWER**  
**AUTOMATIC TRANSMISSION**  
**GARDEN TRACTOR**

- Assembly
- Operation
- Maintenance
- Service and Adjustments
- Repair Parts



# SAFETY RULES



## Safe Operation Practices for Ride-On Mowers

**DANGER: THIS CUTTING MACHINE IS CAPABLE OF AMPUTATING HANDS AND FEET AND THROWING OBJECTS. FAILURE TO OBSERVE THE FOLLOWING SAFETY INSTRUCTIONS COULD RESULT IN SERIOUS INJURY OR DEATH.**



**WARNING:** In order to prevent accidental starting when setting up, transporting, adjusting or making repairs, always disconnect spark plug wire and place wire where it cannot contact spark plug.



**WARNING:** Do not coast down a hill in neutral, you may lose control of the tractor.



**WARNING:** Tow only the attachments that are recommended by and comply with specifications of the manufacturer of your tractor. Use common sense when towing. Operate only at the lowest possible speed when on a slope. Too heavy of a load, while on a slope, is dangerous. Tires can lose traction with the ground and cause you to lose control of your tractor.

### I. GENERAL OPERATION

- Read, understand, and follow all instructions on the machine and in the manual before starting.
- Do not put hands or feet near rotating parts or under the machine. Keep clear of the discharge opening at all times.
- Only allow responsible adults, who are familiar with the instructions, to operate the machine.
- Clear the area of objects such as rocks, toys, wire, etc., which could be picked up and thrown by the blades.
- Be sure the area is clear of bystanders before operating. Stop machine if anyone enters the area.
- Never carry passengers.
- Do not mow in reverse unless absolutely necessary. Always look down and behind before and while backing.
- Never direct discharged material toward anyone. Avoid discharging material against a wall or obstruction. Material may ricochet back toward the operator. Stop the blades when crossing gravel surfaces.
- Do not operate machine without the entire grass catcher, discharge guard, or other safety devices in place and working.
- Slow down before turning.
- Never leave a running machine unattended. Always turn off blades, set parking brake, stop engine, and remove keys before dismounting.
- Disengage blades when not mowing. Shut off engine and wait for all parts to come to a complete stop before cleaning the machine, removing the grass catcher, or unclogging the discharge guard.
- Operate machine only in daylight or good artificial light.
- Do not operate the machine while under the influence of alcohol or drugs.
- Watch for traffic when operating near or crossing roadways.
- Use extra care when loading or unloading the machine into a trailer or truck.
- Always wear eye protection when operating machine.

- Data indicates that operators, age 60 years and above, are involved in a large percentage of riding mower-related injuries. These operators should evaluate their ability to operate the riding mower safely enough to protect themselves and others from serious injury.
- Follow the manufacturer's recommendation for wheel weights or counterweights.
- Keep machine free of grass, leaves or other debris build-up which can touch hot exhaust / engine parts and burn. Do not allow the mower deck to plow leaves or other debris which can cause build-up to occur. Clean any oil or fuel spillage before operating or storing the machine. Allow machine to cool before storage.

### II. SLOPE OPERATION

Slopes are a major factor related to loss of control and tip-over accidents, which can result in severe injury or death. Operation on all slopes requires extra caution. If you cannot back up the slope or if you feel uneasy on it, do not mow it.

- Mow up and down slopes, not across.
- Watch for holes, ruts, bumps, rocks, or other hidden objects. Uneven terrain could overturn the machine. Tall grass can hide obstacles.
- Choose a low ground speed so that you will not have to stop or shift while on the slope.
- Do not mow on wet grass. Tires may lose traction. Always keep the machine in gear when going down slopes. Do not shift to neutral and coast downhill.
- Avoid starting, stopping, or turning on a slope. If the tires lose traction, disengage the blades and proceed slowly straight down the slope.
- Keep all movement on the slopes slow and gradual. Do not make sudden changes in speed or direction, which could cause the machine to roll over.
- Use extra care while operating machine with grass catchers or other attachments; they can affect the stability of the machine. Do no use on steep slopes.
- Do not try to stabilize the machine by putting your foot on the ground.
- Do not mow near drop-offs, ditches, or embankments. The machine could suddenly roll over if a wheel is over the edge or if the edge caves in.

### III. CHILDREN

Tragic accidents can occur if the operator is not alert to the presence of children. Children are often attracted to the machine and the mowing activity. *Never* assume that children will remain where you last saw them.

- Keep children out of the mowing area and in the watchful care of a responsible adult other than the operator.
- Be alert and turn machine off if a child enters the area.
- Before and while backing, look behind and down for small children.
- Never carry children, even with the blades shut off. They may fall off and be seriously injured or interfere with safe machine operation. Children who have been given rides in the past may suddenly appear in the mowing area for another ride and be run over or backed over by the machine.
- Never allow children to operate the machine.
- Use extra care when approaching blind corners, shrubs, trees, or other objects that may block your view of a child.



# SAFETY RULES

## Safe Operation Practices for Ride-On Mowers



### IV. TOWING

- Tow only with a machine that has a hitch designed for towing. Do not attach towed equipment except at the hitch point.
- Follow the manufacturer's recommendation for weight limits for towed equipment and towing on slopes.
- Never allow children or others in or on towed equipment.
- On slopes, the weight of the towed equipment may cause loss of traction and loss of control.
- Travel slowly and allow extra distance to stop.

### V. SERVICE

#### SAFE HANDLING OF GASOLINE

To avoid personal injury or property damage, use extreme care in handling gasoline. Gasoline is extremely flammable and the vapors are explosive.

- Extinguish all cigarettes, cigars, pipes, and other sources of ignition.
- Use only approved gasoline container.
- Never remove gas cap or add fuel with the engine running. Allow engine to cool before refueling.
- Never fuel the machine indoors.
- Never store the machine or fuel container where there is an open flame, spark, or pilot light such as on a water heater or other appliances.
- Never fill containers inside a vehicle or on a truck or trailer bed with plastic liner. Always place containers on the ground away from your vehicle when filling.
- Remove gas-powered equipment from the truck or trailer and refuel it on the ground. If this is not possible, then refuel such equipment with a portable container, rather than from a gasoline dispenser nozzle.
- Keep the nozzle in contact with the rim of the fuel tank or container opening at all times until fueling is complete. Do not use a nozzle lock-open device.
- If fuel is spilled on clothing, change clothing immediately.
- Never overfill fuel tank. Replace gas cap and tighten securely.

#### GENERAL SERVICE

- Never operate machine in a closed area.
- Keep all nuts and bolts tight to be sure the equipment is in safe working condition.
- Never tamper with safety devices. Check their proper operation regularly.
- Keep machine free of grass, leaves, or other debris build-up. Clean oil or fuel spillage and remove any fuel-soaked debris. Allow machine to cool before storing.
- If you strike a foreign object, stop and inspect the machine. Repair, if necessary, before restarting.

- Never make any adjustments or repairs with the engine running.
- Check grass catcher components and the discharge guard frequently and replace with manufacturer's recommended parts, when necessary.
- Mower blades are sharp. Wrap the blade or wear gloves, and use extra caution when servicing them.
- Check brake operation frequently. Adjust and service as required.
- Maintain or replace safety and instruction labels, as necessary.



- Be sure the area is clear of bystanders before operating. Stop machine if anyone enters the area.
- Never carry passengers.
- Do not mow in reverse unless absolutely necessary. Always look down and behind before and while backing.
- Never carry children, even with the blades shut off. They may fall off and be seriously injured or interfere with safe machine operation. Children who have been given rides in the past may suddenly appear in the mowing area for another ride and be run over or backed over by the machine.
- Keep children out of the mowing area and in the watchful care of a responsible adult other than the operator.
- Be alert and turn machine off if a child enters the area.
- Before and while backing, look behind and down for small children.
- Mow up and down slopes (15° Max), not across.
- Choose a low ground speed so that you will not have to stop or shift while on the slope.
- Avoid starting, stopping, or turning on a slope. If the tires lose traction, disengage the blades and proceed slowly straight down the slope.
- If machine stops while going uphill, disengage blades, shift into reverse and back down slowly.
- Do not turn on slopes unless necessary, and then, turn slowly and gradually downhill, if possible.

## TABLE OF CONTENTS

SAFETY RULES .....	2-3
PRODUCT SPECIFICATIONS .....	4
CUSTOMER RESPONSIBILITIES .....	4
WARRANTY .....	4
ASSEMBLY .....	5-9
OPERATION .....	10-16
MAINTENANCE SCHEDULE .....	17

MAINTENANCE .....	17-20
SERVICE AND ADJUSTMENTS .....	21-25
STORAGE .....	26
TROUBLESHOOTING .....	27-28
REPAIR PARTS - TRACTOR .....	29-43
REPAIR PARTS - ENGINE .....	49-49
PARTS ORDERING/SERVICE .....	BACK COVER

## PRODUCT SPECIFICATIONS

Gasoline Capacity and type:	4 Gallons Unleaded Regular
Oil Type (API-SG-SL):	SAE 10w30 (above 32°F) SAE 5W-30 (below 32°F) Synthetic (below 0°F)
Your tractor was shipped from the factory with non-synthetic SAE 10W30 motor oil	
Oil Capacity:	W/Filter: 1.8 Quarts
Spark Plug: (Gap: .030")	Champion RC12YC
Ground Speed (MPH):	Forward: 5.8 Reverse: 2.1
Charging System:	15 Amps @ 3600RPM
Battery:	AMP/HR: 35 Min. CCA: 280 Case Size: U1R
Blade Bolt Torque:	45-55 FT. LBS.

**CONGRATULATIONS** on your purchase of a new Tractor. It has been designed, engineered and manufactured to give you the best possible dependability and performance.

Should you experience any problem you cannot easily remedy, please contact your nearest authorized service center/department. We have competent, well-trained technicians and the proper tools to service or repair this tractor.

Please read and retain this manual. The instructions will enable you to assemble and maintain your tractor properly. Always observe the "SAFETY RULES".

## MAINTENANCE AGREEMENT

A Maintenance Agreement is available on this product. Contact your nearest Sears store for details.

## CUSTOMER RESPONSIBILITIES

- Read and observe the safety rules.
- Follow a regular schedule in maintaining, caring for and using your tractor.
- Follow the instructions under "Maintenance" and "Storage" sections of this owner's manual.

**WARNING:** This tractor is equipped with an internal combustion engine and should not be used on or near any unimproved forest-covered, brush-covered or grass-covered land unless the engine's exhaust system is equipped with a spark arrester meeting applicable local or state laws (if any). If a spark arrester is used, it should be maintained in effective working order by the operator.

A spark arrester for the muffler is available through your nearest authorized service center/department (See REPAIR PARTS section of this manual).

### LIMITED TWO (2) YEAR WARRANTY ON CRAFTSMAN TRACTOR (RIDING EQUIPMENT)

For two (2) years from date of purchase Sears Canada, Inc. will repair or replace at Sears option free of charge parts which are defective as a result of material or workmanship.

### FULL ONE (1) YEAR WARRANTY ON BATTERY

For one (1) year from date of purchase, if any battery included with this riding equipment proves defective in material or workmanship and our testing determines the battery will not hold a charge, Sears will replace the battery at no charge.

### COMMERCIAL OR RENTAL USE

Warranty on Riding Equipment used for commercial or rental purposes is limited to ninety (90) days.

### This Warranty does **NOT** cover:

1. Pre-delivery set-up.
2. Tire replacement or repair caused by punctures from outside objects (such as nails, thorns, stumps, or glass).
3. Expendable items which become worn during normal use, such as blades, spark plug, air cleaners and belts.
4. Repairs necessary because of operator abuse or negligence, including damaged jackshaft or mandrel and the failure to operate and maintain the equipment according to the instructions contained in the Owner's Manual.

Warranty service is available by returning the Craftsman Riding Equipment to the nearest Sears Service Centre/Department in Canada. This warranty applies only while this product is in use in Canada.

This warranty is in addition to any statutory warranty and does not exclude or limit legal rights you may have but shall run concurrently with applicable provincial legislation. Furthermore, some provinces do NOT allow limitation on how long an implied warranty will last so the above limitations may not apply to you.

**SEARS CANADA, INC., TORONTO, ONTARIO M5B 2B8**

# UNASSEMBLED PARTS

## Mower



(5) Large Retainer Springs - 7/16



(2) Smaller Retainer Springs - 5/16

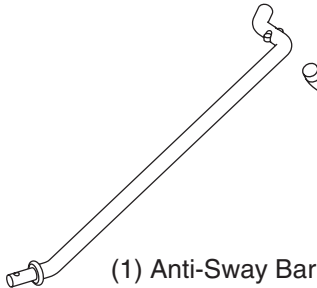

(1) Anti-Sway Bar

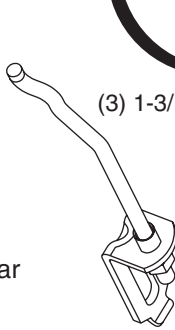

(2) Rear Lift Link Assemblies

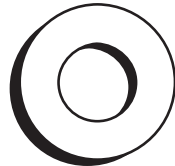

(1) 3/4 O.D. Washers

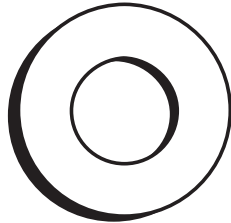

(3) 1-3/16 O.D. Washers

## Mower Front Wheel



(1) Wheel

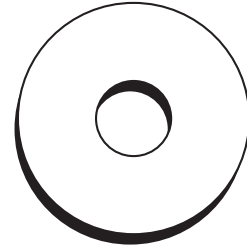

(1) 1-1/4 O.D. Washer



(1) Shoulder Bolt



(1) Locknut 3/8-16

## Battery



(2) Hex Bolts 1/4-20 x 3/4

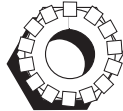

(2) Keps Nut 1/4-20



(1) Oil Drain Tube For Future Use

## Keys

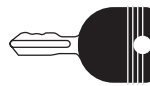

(2) Keys

## Slope Sheet

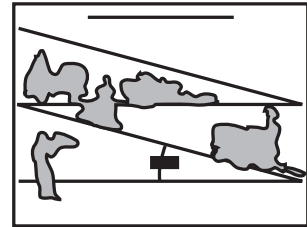

# ASSEMBLY

Your new tractor has been assembled at the factory with exception of those parts left unassembled for shipping purposes.

## TOOLS REQUIRED FOR ASSEMBLY

A socket wrench set will make assembly easier. Standard wrench sizes are listed.

- (1) 3/4" wrench                      (1) Utility knife
- (1) 9/16" wrench                    (1) Pliers
- (1) Tire Pressure Gauge

When right or left hand is mentioned in this manual, it means from your point of view, when you are in the operating position (seated behind the steering wheel).

## TO REMOVE TRACTOR FROM CARTON

### UNPACK CARTON

- Remove all accessible loose parts and parts cartons from carton .
- Cut along dashed lines on all four panels of carton. Remove end panels and lay side panels flat.
- Remove mower and packing materials.
- Check for any additional loose parts or cartons and remove.

### CONNECT BATTERY (See Fig. 1)



**CAUTION: Do not short battery terminals by allowing a wrench or any other object to contact both terminals at the same time. Before connecting battery, remove metal bracelets, wristwatch bands, etc.**

**Positive terminal must be connected first to prevent sparking from accidental grounding.**

- Lift hood to raised position.
- Remove terminal protective caps and discard.

**NOTE:** If this battery is put into service after month and year indicated on label (L) (label located between terminals) charge battery for minimum of one hour at 6-10 amps.

- First connect RED battery cable to positive (+) terminal with hex bolt and keps nut.
- Connect BLACK grounding cable to negative (-) terminal with remaining hex bolt and keps nut. Tighten securely.

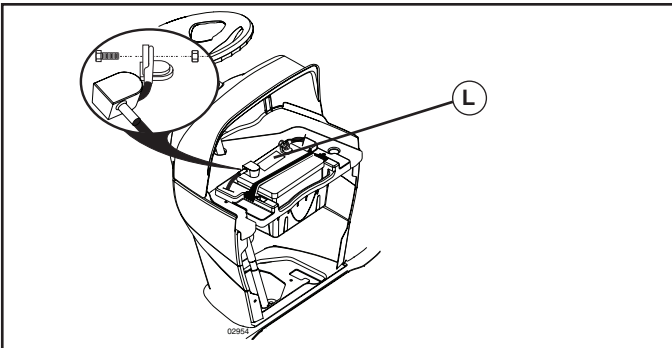

FIG. 1

### ADJUST SEAT (See Fig. 2)

- Sit in seat.
- Lift up adjustment lever (A) and slide seat until a comfortable position is reached which allows you to press clutch/brake pedal all the way down.
- Release lever to lock seat in position.

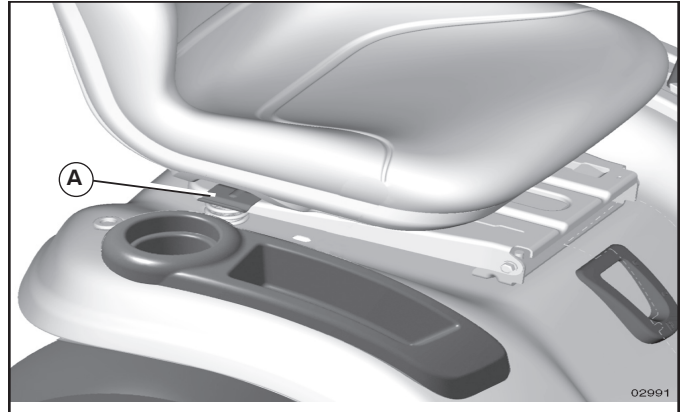

FIG. 2

**NOTE:** You may now roll or drive your tractor off the skid. Follow the appropriate instruction below to remove the tractor from the skid.

**⚠ WARNING:** Before starting, read, understand and follow all instructions in the Operation section of this manual. Be sure tractor is in a well-ventilated area. Be sure the area in front of tractor is clear of other people and objects.

### TO ROLL TRACTOR OFF SKID (See Operation section for location and function of controls)

- Raise attachment lift lever to its highest position.
- Release parking brake by depressing brake pedal.
- Place freewheel control in disengaged position to disengage transmission (See "TO TRANSPORT" in the Operation section of this manual).
- Roll tractor forward off skid.

### TO DRIVE TRACTOR OFF SKID (See Operation section for location and function of controls)

- Be sure all the above assembly steps have been completed.
- Check engine oil level and fill fuel tank with gasoline.
- Place freewheel control in "transmission engaged" position (see "TO TRANSPORT" in Operation section of this manual).
- Sit on seat in operating position, depress brake pedal and set the parking brake.
- Raise attachment lift lever to its highest position.
- Remove key from bag and start the engine (see "TO START" in the Operation section of this manual). After engine has started, move throttle control to idle (slow) position.
- Release parking brake.

# ASSEMBLY

- Slowly depress forward drive pedal and drive tractor off skid.
- Apply brake to stop tractor and set parking brake.
- Turn ignition key to "STOP" position.

Continue with the instructions that follow.

## ASSEMBLE FRONT WHEEL TO MOWER (See Fig. 3)

- Using shoulder bolt, washer and locknut from parts bag, assemble front wheel to mower as shown. Tighten securely.

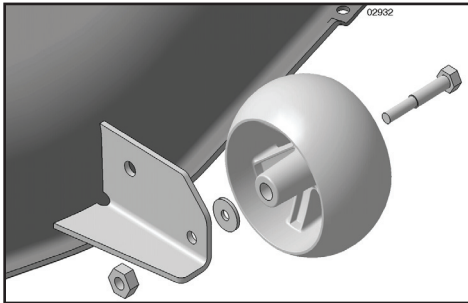



FIG. 3

## INSTALL MOWER AND DRIVE BELT (See Figs. 4-12)

See MOWER AND DRIVE BELT ASSEMBLY Supplement Sheet for additional guidance on this assembly.

Be sure tractor is on level surface and engage parking brake.

- Lower attachment lift lever to it's lowest position.



**CAUTION:** Lift lever is spring loaded. Have a tight grip on lift lever, lower it slowly and engage in lowest position.

- Turn steering wheel to the left as far as it will go and position mower on right side of tractor with deflector shield to the right.

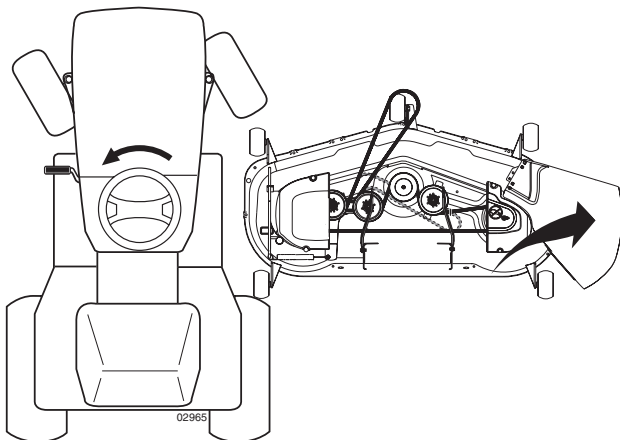

FIG. 4

- Remove plastic tie securing belt, bring belt forward and check belt for proper routing in all mower pulley grooves.

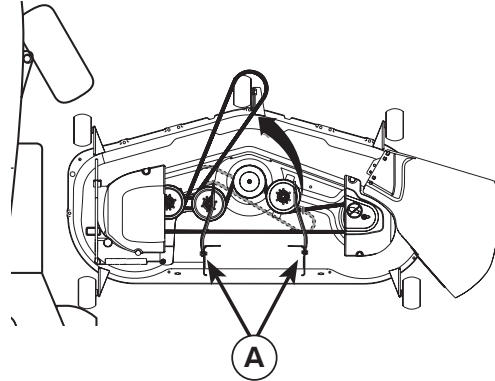

FIG. 5

**NOTE:** Be sure mower side suspension arms (A) are pointing forward before sliding mower under tractor.

- Slide mower under tractor until it is centered under tractor.
- **FIRST INSTALL ANTI-SWAY BAR (S).**
  - From right side of mower, insert anti-sway bar into hole in transmission bracket (T).

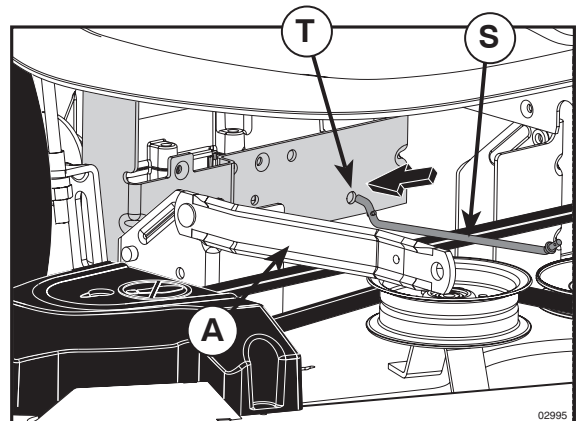

FIG. 6

- Pivot bar towards you and insert other end of bar into hole in rear mower bracket (D). Move mower as needed to insert bar.
- Secure with washer and retainer spring as shown using small 5/16 retainer spring.

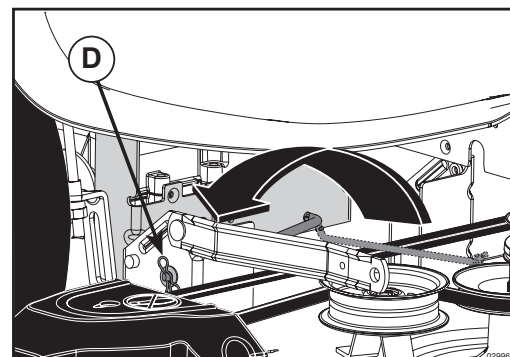

FIG. 7

# ASSEMBLY

- ATTACH MOWER SIDE SUSPENSION ARMS (A) TO CHASSIS - Position hole in arm over pin (B) on outside of tractor chassis and secure with retainer spring.
- Repeat on opposite side of tractor.
- ATTACH REAR LIFT LINKS (C) - Insert rod end of lift

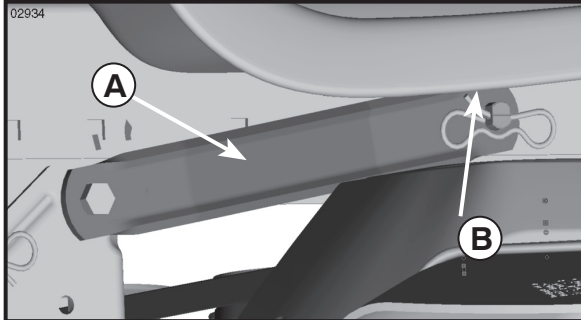

FIG. 8

link assembly into hole in tractor lift shaft suspension arm (L) and pivot link down to mower. Lift rear corner of mower and position slot in link assembly over pin on rear mower bracket (D) and secure with washer and retainer spring.

- Repeat on opposite side of tractor.
- Turn steering wheel to position wheels straight for-

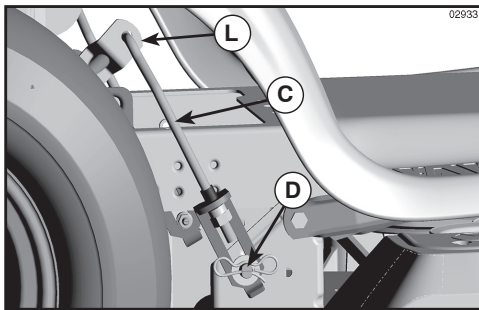

FIG. 9

ward.

- ATTACH FRONT LINK (E) - Work from left side of tractor. Insert rod end of link assembly through front hole in tractor front suspension bracket (F) and secure with 7/16 retainer spring (G) through hole in link located behind the bracket.
- Insert other end of link (E) into hole in front mower bracket (H) and secure with washer and 5/16 retainer spring (J).
- Disengage belt tension rod (K) from locking bracket

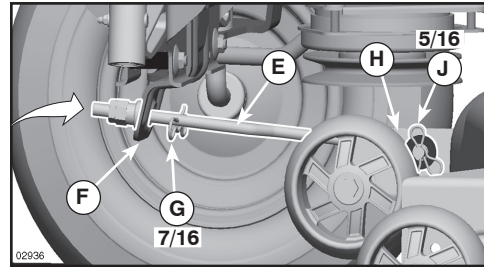

FIG. 10

(L).

- Install belt onto engine clutch pulley (M).

**IMPORTANT:** Check belt for proper routing in all mower pulley grooves.

- Engage belt tension rod (K) on locking bracket (L).

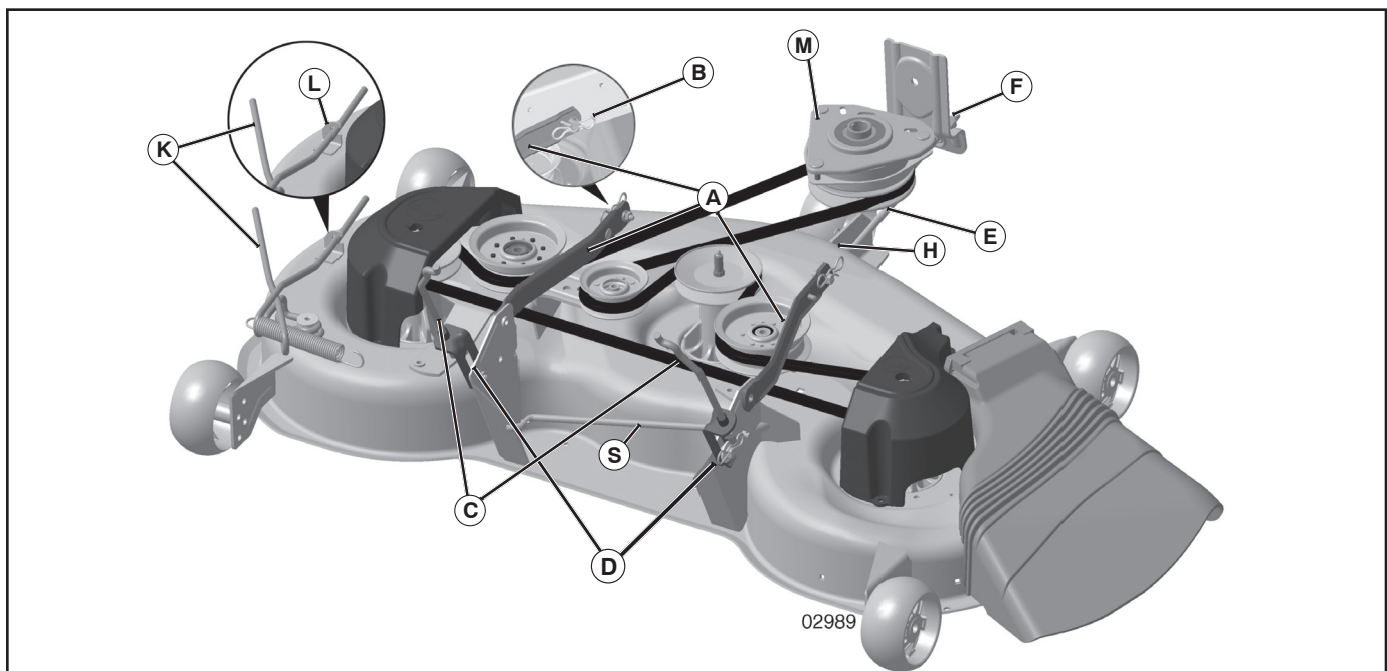

FIG. 11



# ASSEMBLY

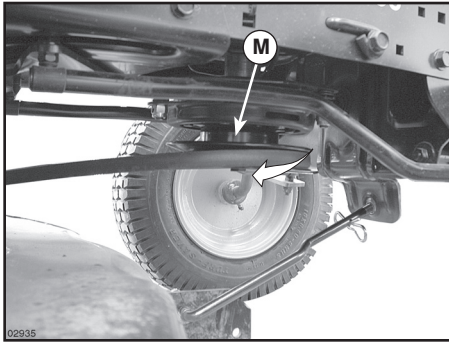

FIG. 12

**CAUTION:** Belt tension rod is spring loaded. Have a tight grip on rod and engage slowly.



• Raise attachment lift lever to highest position.

• If necessary, adjust gauge wheels before operating mower as shown in the Operation section of this manual.

## CHECK TIRE PRESSURE

The tires on your tractor were overinflated at the factory for shipping purposes. Correct tire pressure is important for best cutting performance.

- Reduce tire pressure to PSI shown on tires.

## CHECK DECK LEVELNESS

For best cutting results, mower housing should be properly leveled. See "TO LEVEL MOWER HOUSING" in the Service and Adjustments section of this manual.

## CHECK FOR PROPER POSITION OF ALL BELTS

See the figures that are shown for replacing motion and mower blade drive belts in the Service and Adjustments section of this manual. Verify that the belts are routed correctly.

## CHECK BRAKE SYSTEM

After you learn how to operate your tractor, check to see that the brake is operating properly. See "TO CHECK BRAKE" in the Service and Adjustments section of this manual.

## ✓CHECKLIST

*BEFORE YOU OPERATE YOUR NEW TRACTOR, WE WISH TO ASSURE THAT YOU RECEIVE THE BEST PERFORMANCE AND SATISFACTION FROM THIS QUALITY PRODUCT.*

*PLEASE REVIEW THE FOLLOWING CHECKLIST:*

- ✓ All assembly instructions have been completed.
- ✓ No remaining loose parts in carton.
- ✓ Battery is properly prepared and charged.
- ✓ Seat is adjusted comfortably and tightened securely.
- ✓ All tires are properly inflated. (For shipping purposes, the tires were overinflated at the factory).
- ✓ Be sure mower deck is properly leveled side-to-side/front-to-rear for best cutting results. (Tires must be properly inflated for leveling).
- ✓ Check mower and drive belts. Be sure they are routed properly around pulleys and inside all belt keepers.
- ✓ Check wiring. See that all connections are still secure and wires are properly clamped.
- ✓ Before driving tractor, be sure freewheel control is in "transmission engaged" position (see "TO TRANSPORT" in the Operation section of this manual).

**WHILE LEARNING HOW TO USE YOUR TRACTOR, PAY EXTRA ATTENTION TO THE FOLLOWING IMPORTANT ITEMS:**

- ✓ Engine oil is at proper level.
- ✓ Fuel tank is filled with fresh, clean, regular unleaded gasoline.
- ✓ Become familiar with all controls, their location and function. Operate them before you start the engine.
- ✓ Be sure brake system is in safe operating condition.
- ✓ Be sure Operator Presence System and Reverse Operation System (ROS) are working properly (See the Operation and Maintenance sections in this manual).
- ✓ It is important to purge the transmission before operating your tractor for the first time. Follow proper starting and transmission purging instructions (See "TO START ENGINE" and "PURGE TRANSMISSION" in the Operation section of this manual).

# OPERATION

These symbols may appear on your tractor or in literature supplied with the product. Learn and understand their meaning.

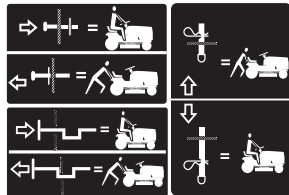

FREE WHEEL  
(Automatic Models only)



Failure to follow instructions could result in serious injury or death. The safety alert symbol is used to identify safety information about hazards which can result in death, serious injury and/or property damage.



**DANGER** indicates a hazard which, if not avoided, will result in death or serious injury.



**WARNING** indicates a hazard which, if not avoided, could result in death or serious injury.



**CAUTION** indicates a hazard which, if not avoided, might result in minor or moderate injury.

**CAUTION** when used **without** the alert symbol, indicates a situation that **could result in damage to the tractor and/or engine.**



**HOT SURFACES** indicates a hazard which, if not avoided, could result in death, serious injury and/or property damage.



**FIRE** indicates a hazard which, if not avoided, could result in death, serious injury and/or property damage.

# OPERATION

## KNOW YOUR TRACTOR

### READ THIS OWNER'S MANUAL AND SAFETY RULES BEFORE OPERATING YOUR TRACTOR

Compare the illustrations with your tractor to familiarize yourself with the locations of various controls and adjustments. Save this manual for future reference.

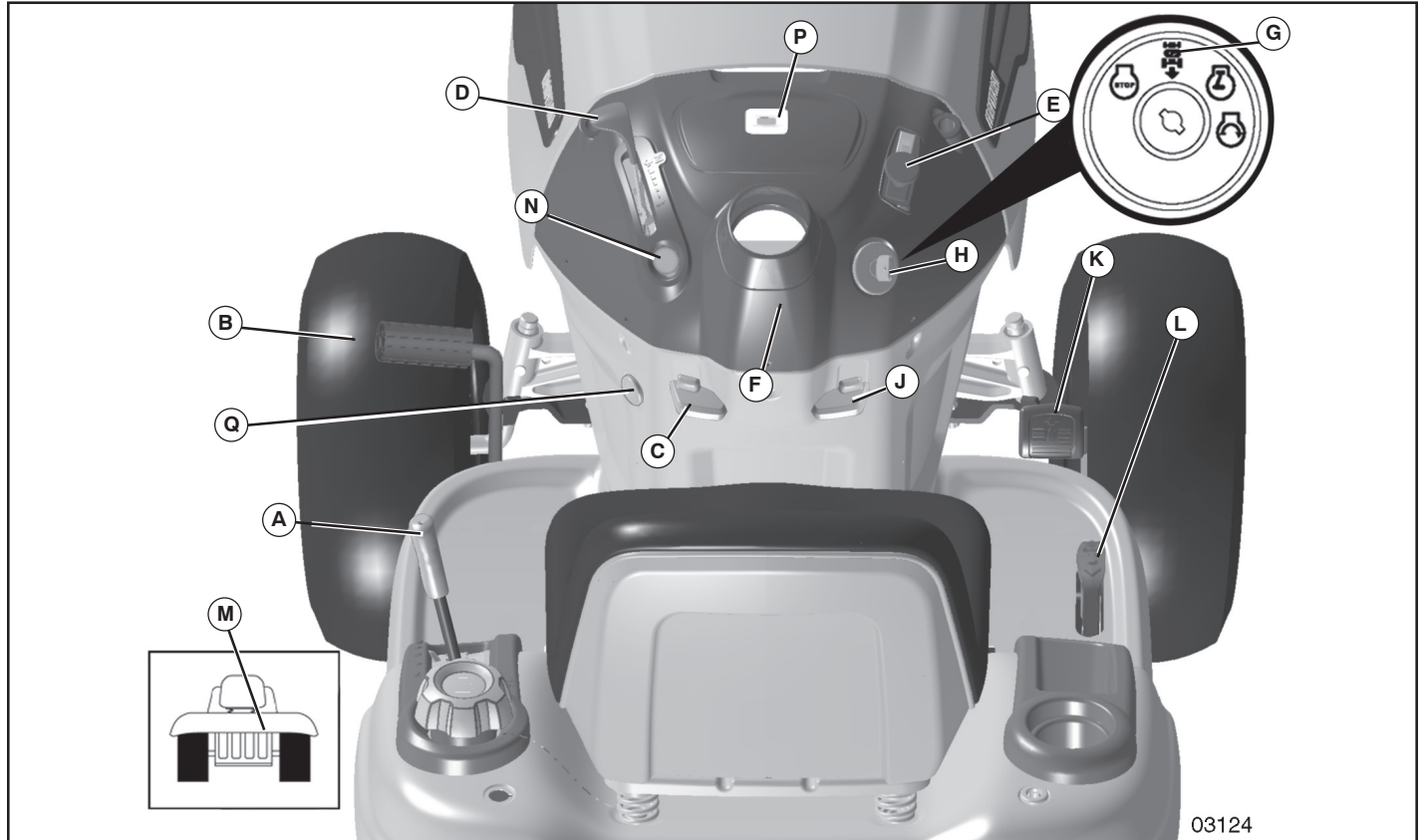

FIG. 13

Our tractors conform to the applicable safety standards of the American National Standards Institute.

**(A) ATTACHMENT LIFT LEVER** – Used to raise and lower the mower or other attachments mounted to your tractor.

**(B) BRAKE PEDAL** – Used for braking the tractor and starting the engine.

**(C) PARKING BRAKE** – Locks clutch/brake pedal into the brake position.

**(D) THROTTLE CONTROL** – Used to control engine speed.

**(E) ATTACHMENT CLUTCH SWITCH** – Used to engage the mower blades, or other attachments mounted to your tractor.

**(F) IGNITION SWITCH** – Used for starting and stopping the engine.

**(G) REVERSE OPERATION SYSTEM (ROS) "ON" POSITION** – Allows operation of mower or other powered attachment while in reverse.

**(H) LIGHT SWITCH** – Turns the headlights on and off.

**(J) CRUISE CONTROL LEVER** – Used to set forward movement of tractor at desired speed without holding the forward drive pedal.

**(K) FORWARD DRIVE PEDAL** – Used for forward movement of tractor.

**(L) REVERSE DRIVE PEDAL** – Used for reverse movement of tractor.

**(M) FREEWHEEL CONTROL** – Disengages transmission for pushing or slowly towing the tractor with the engine off.

**(N) CHOKE CONTROL** – Used when starting a cold engine.

**(P) SERVICE REMINDER / HOUR METER** – Indicates when service is required for the engine and mower.

**(Q) 12-VOLT POWER PORT** – Used for 12-volt accessories.

# OPERATION



The operation of any tractor can result in foreign objects thrown into the eyes, which can result in severe eye damage. Always wear safety glasses or eye shields while operating your tractor or performing any adjustments or repairs. We recommend standard safety glasses or a wide vision safety mask worn over spectacles.

## HOW TO USE YOUR TRACTOR

### TO SET PARKING BRAKE(See Fig. 14)

Your tractor is equipped with an operator presence sensing switch. When engine is running, any attempt by the operator to leave the seat without first setting the parking brake will shut off the engine.

- Depress brake pedal (B) all the way down and hold.
- Pull parking brake lever (C) up and hold, release pressure from brake pedal (B), then release parking brake lever. Pedal should remain in brake position. Make sure parking brake will hold tractor secure.

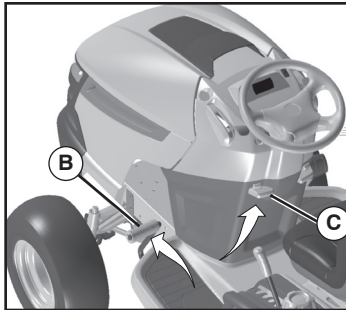
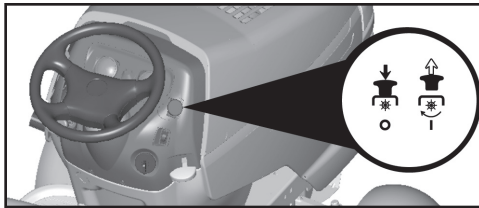

FIG. 14

## STOPPING

### MOWER BLADES

- To stop mower blades, push attachment clutch switch in to disengaged position (⚙).



(⚙) ATTACHMENT CLUTCH ENGAGE POSITION  
(⚙) DISENGAGED POSITION

FIG. 15

### GROUND DRIVE -

- To stop ground drive, depress brake pedal all the way down.

### ENGINE -

- Move throttle control (D) between half and full speed (fast) position.

**NOTE:** Failure to move throttle control between half and full speed (fast) position, before stopping, may cause engine to “backfire”.

- Turn ignition key (F) to “STOP” position and remove key. Always remove key when leaving tractor to prevent unauthorized use.
- Never use choke (N) to stop engine.

**IMPORTANT:** Leaving the ignition switch in any position other than “STOP” will cause the battery to discharge and go dead.

**NOTE:** Under certain conditions when tractor is standing idle with the engine running, hot engine exhaust gases may cause “browning” of grass. To eliminate this possibility, always stop engine when stopping tractor on grass areas.



**CAUTION:** Always stop tractor completely, as described above, before leaving the operator's position.

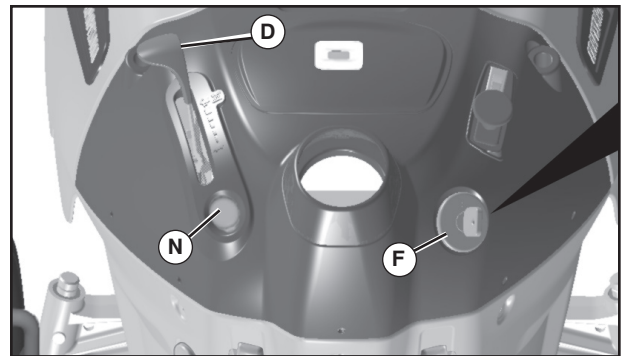

FIG. 16

### TO USE THROTTLE CONTROL (See Fig. 16)

Always operate engine at full speed (fast).

- Operating engine at less than full speed (fast) reduces engines operating efficiency.
- Full speed (fast) offers the best bagging and mower performance.

### TO USE CHOKE CONTROL -D (See Fig. 16)

Use choke control whenever you are starting a cold engine. Do not use to start a warm engine.

- To engage choke control, pull knob out. Slowly push knob in to disengage.

### TO MOVE FORWARD AND BACKWARD -N (See Fig. 17)

The direction and speed of movement is controlled by the forward and reverse drive pedals.

- Start tractor and release parking brake.
- Slowly depress forward (K) or reverse (L) drive pedal to begin movement. Ground speed increases the further down the pedal is depressed.

# OPERATION

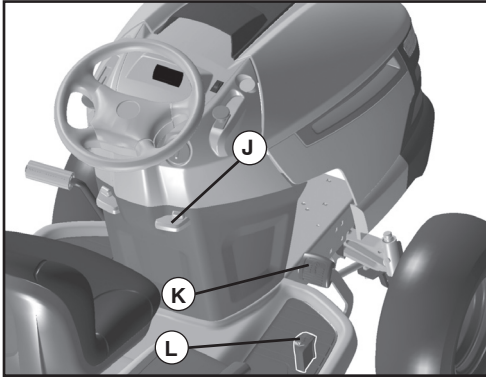

FIG. 17

## TO USE CRUISE CONTROL -J (See Fig. 17)

The cruise control feature can be used for forward travel only.

### SYSTEM CHARACTERISTICS

The cruise control should only be used while mowing or transporting on relatively smooth, straight surfaces. Other conditions such as trimming at slow speeds may cause the cruise control to disengage. Do not use the cruise control on slopes, rough terrain or while trimming or turning.

- With forward drive pedal depressed to desired speed, pull cruise control lever (J) up and hold while lifting your foot off the pedal, then release the lever.

To disengage the cruise control, depress the brake pedal or tap on forward drive pedal.

## TO ADJUST MOWER CUTTING HEIGHT (See Fig. 18)

The position of the attachment lift lever (A) determines the cutting height.

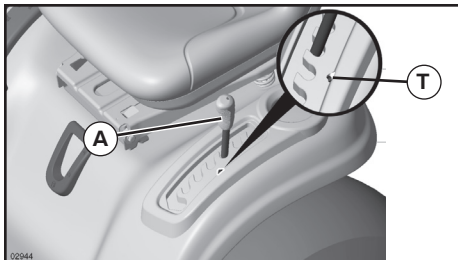

FIG. 18

- Put attachment lift lever in desired cutting height slot.
- Slide pointer tab (T) to desired cutting height as a reminder for next time you mow.

The cutting height range is approximately 1" to 4". The heights are measured from the ground to the blade tip with the engine not running. These heights are approximate and may vary depending upon soil conditions, height of grass and types of grass being mowed.

- The average lawn should be cut to approximately 2-1/2 inches during the cool season and to over 3 inches during hot months. For healthier and better looking lawns, mow often and after moderate growth.
- For best cutting performance, grass over 6 inches in height should be mowed twice. Make the first cut relatively high; the second to desired height.

## TO ADJUST GAUGE WHEELS (See Fig. 19)

Gauge wheels are properly adjusted when they are slightly off the ground when mower is at the desired cutting height in operating position. Gauge wheels then keep the deck in proper position to help prevent scalping in most terrain conditions.

**NOTE:** Adjust gauge wheels with tractor on a flat level surface.

- Adjust mower to desired cutting height (See "TO ADJUST MOWER CUTTING HEIGHT" in this section of manual).
- With mower in desired height of cut position, gauge wheels should be assembled so they are slightly off the ground. Install gauge wheel in appropriate hole. Tighten securely.
- Repeat for all, installing gauge wheel in same adjustment hole.

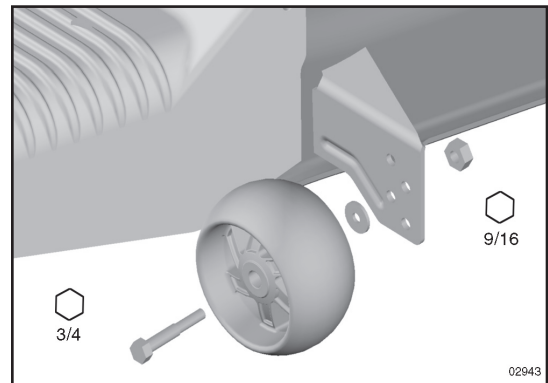

FIG. 19

## TO OPERATE MOWER

Your tractor is equipped with an operator presence sensing switch. Any attempt by the operator to leave the seat with the engine running and the attachment clutch engaged will shut off the engine. You must remain fully and centrally positioned in the seat to prevent the engine from hesitating or cutting off when operating your equipment on rough, rolling terrain or hills.

1. Select desired height of cut with attachment lift lever.
2. Start mower blades by engaging attachment clutch control.

TO STOP MOWER BLADES - disengage attachment clutch control.



**CAUTION:** Do not operate the mower without either the entire grass catcher, on mowers so equipped, or the deflector shield (S) in place.

# OPERATION

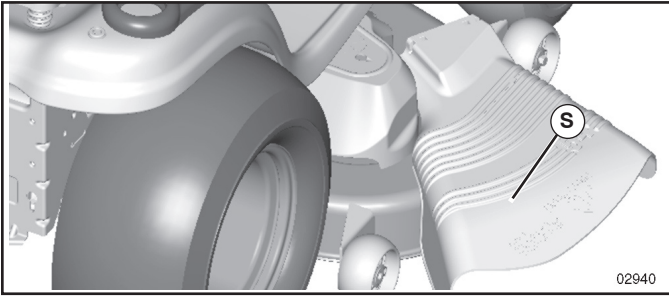

FIG. 20

## REVERSE OPERATION SYSTEM (ROS)

Your tractor is equipped with a Reverse Operation System (ROS). Any attempt by the operator to travel in the reverse direction with the attachment clutch engaged will shut off the engine unless ignition key is placed in the ROS "ON" position.

**⚠WARNING:** Backing up with the attachment clutch engaged while mowing is strongly discouraged. Turning the ROS "ON", to allow reverse operation with the attachment clutch engaged, should only be done when the operator decides it is necessary to reposition the machine with the attachment engaged. **Do not mow in reverse unless absolutely necessary.**

### USING THE REVERSE OPERATION SYSTEM -

Only use if you are certain no children or other bystanders will enter the mowing area.

- Depress brake pedal all the way down.
- With engine running, turn ignition key counterclockwise to ROS "ON" position.
- Look down and behind before and while backing.
- Slowly depress reverse drive pedal to start movement.
- When use of the ROS is no longer needed, turn the ignition key clockwise to engine "ON" position.

ROS "ON" POSITION



ENGINE "ON" POSITION  
(NORMAL OPERATING)



## TO OPERATE ON HILLS



**CAUTION: Do not drive up or down hills with slopes greater than 15° and do not drive across any slope.**

- Choose the slowest speed before starting up or down hills.
- Avoid stopping or changing speed on hills.
- If stopping is absolutely necessary, push brake pedal quickly to brake position and engage parking brake.

- To restart movement, slowly release parking brake and brake pedal.
- Slowly depress appropriate drive pedal to slowest setting.
- Make all turns slowly.

## TO TRANSPORT (See Figs. 13 and 21)

When pushing or towing your tractor, be sure to disengage transmission by placing freewheel control in freewheeling position. Free wheel control is located at the rear drawbar of tractor.

- Raise attachment lift to highest position with attachment lift control.
- Pull freewheel control out and down into the slot and release so it is held in the disengaged position.
- Do not push or tow tractor at more than two (2) MPH.
- To reengage transmission, reverse above procedure.

**NOTE:** To protect hood from damage when transporting your tractor on a truck or a trailer, be sure hood is closed and secured to tractor. Use an appropriate means of tying hood to tractor (rope, cord, etc.).

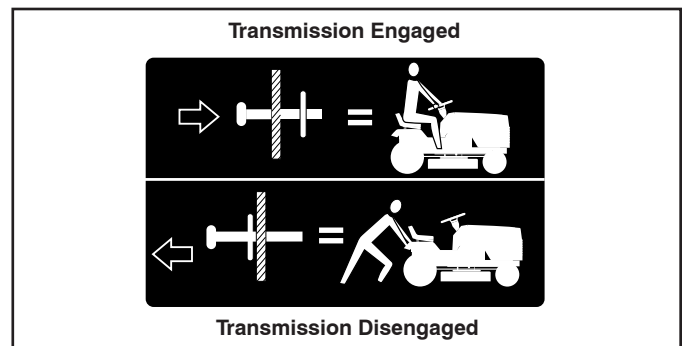

FIG. 21

## SERVICE REMINDER/HOUR METER

Service reminder shows the total number of hours the engine has run and flashes to indicate that the engine or mower needs servicing. When service is required, the service reminder will flash for two hours. To service engine and mower, see the Maintenance section of this manual.

**NOTE:** Service reminder runs when the ignition key is in any position but "STOP". For accurate reading, be sure key remains in the "STOP" position when engine is not running.

## TOWING CARTS AND OTHER ATTACHMENTS

Tow only the attachments that are recommended by and comply with specifications of the manufacturer of your tractor. Use common sense when towing. Too heavy of a load, while on a slope, is dangerous. Tires can lose traction with the ground and cause you to lose control of your tractor.

# OPERATION

## BEFORE STARTING THE ENGINE

### CHECK ENGINE OIL LEVEL

The engine in your tractor has been shipped, from the factory, already filled with summer weight oil.

- Check engine oil with tractor on level ground.
- Unthread and remove oil fill cap/dipstick; wipe oil off. Reinsert the dipstick into the tube and rest oil fill cap on the tube. Do not thread the cap onto the tube. Remove and read oil level. If necessary, add oil until "FULL" mark on dipstick is reached. Do not overfill.
- For cold weather operation you should change oil for easier starting (See "OIL VISCOSITY CHART" in the Maintenance section of this manual).
- To change engine oil, see the Maintenance section in this manual.

### ADD GASOLINE

- Fill fuel tank to bottom of filler neck. Do not overfill. Use fresh, clean, regular unleaded gasoline with a minimum of 87 octane. (Use of leaded gasoline will increase carbon and lead oxide deposits and reduce valve life). Do not mix oil with gasoline. Purchase fuel in quantities that can be used within 30 days to assure fuel freshness.



**CAUTION: Wipe off any spilled oil or fuel. Do not store, spill or use gasoline near an open flame.**

**IMPORTANT:** WHEN OPERATING IN TEMPERATURES BELOW 32°F (0°C), USE FRESH, CLEAN WINTER GRADE GASOLINE TO HELP INSURE GOOD COLD WEATHER STARTING.

**CAUTION: Alcohol blended fuels (called gasohol or using ethanol or methanol) can attract moisture which leads to separation and formation of acids during storage. Acidic gas can damage the fuel system of an engine while in storage. To avoid engine problems, the fuel system should be emptied before storage of 30 days or longer. Drain the gas tank, start the engine and let it run until the fuel lines and carburetor are empty. Use fresh fuel next season. See Storage Instructions for additional information. Never use engine or carburetor cleaner products in the fuel tank or permanent damage may occur.**

### TO START ENGINE (See Fig. 13)

When starting the engine for the first time or if the engine has run out of fuel, it will take extra cranking time to move fuel from the tank to the engine.

- Be sure freewheel control is in the transmission engaged position.
- Sit on seat in operating position, depress brake pedal and set parking brake.
- Move attachment clutch to "DISENGAGED" position.
- Move throttle control to fast position
- Pull choke control out for a cold engine start attempt. For a warm engine start attempt the choke control may not be needed.

**NOTE:** Before starting, read the warm and cold starting procedures below.

- Insert key into ignition and turn key clockwise to "START" position and release key as soon as engine starts. Do not run starter continuously for more than fifteen seconds per minute. If the engine does not start after several attempts, push choke control in, wait a few minutes and try again. If engine still does not start, pull the choke control out and retry.

### WARM WEATHER STARTING (50° F and above)

- When engine starts, slowly push choke control in until the engine begins to run smoothly. If the engine starts to run roughly, pull the choke control out slightly for a few seconds and then continue to push the control in slowly.
- The attachments and ground drive can now be used. If the engine does not accept the load, restart the engine and allow it to warm up for one minute using the choke as described above.

### COLD WEATHER STARTING (50° F and below)

- When engine starts, slowly push choke control in until the engine begins to run smoothly. Continue to push the choke control in small steps allowing the engine to accept small changes in speed and load, until the choke control is fully in. If the engine starts to run roughly, pull the choke control out slightly for a few seconds and then continue to push the control in slowly. This may require an engine warm-up period from several seconds to several minutes, depending on the temperature.

### AUTOMATIC TRANSMISSION WARM UP

- Before driving the unit in cold weather, the transmission should be warmed up as follows:
  - Be sure the tractor is on level ground.
  - Release the parking brake and let the brake slowly return to operating position.
  - Allow one minute for transmission to warm up. This can be done during the engine warm up period.
- The attachments can be used during the engine warm-up period after the transmission has been warmed up and may require the choke control be pulled out slightly.

**NOTE:** If at a high altitude (above 3000 feet) or in cold temperatures (below 32 F) the carburetor fuel mixture may need to be adjusted for best engine performance. See "TO ADJUST CARBURETOR" in the Service and Adjustments section of this manual.

### PURGE TRANSMISSION



**CAUTION: Never engage or disengage freewheel lever while the engine is running.**

To ensure proper operation and performance, it is recommended that the transmission be purged before operating tractor for the first time. This procedure will remove any trapped air inside the transmission which may have developed during shipping of your tractor.

**IMPORTANT:** SHOULD YOUR TRANSMISSION REQUIRE REMOVAL FOR SERVICE OR REPLACEMENT, IT SHOULD BE PURGED AFTER REINSTALLATION BEFORE OPERATING THE TRACTOR.

1. Place tractor safely on a level surface - that is clear and open - with engine off and parking brake set.

# OPERATION

2. Disengage transmission by placing freewheel control in freewheeling position (See "TO TRANSPORT" in this section of manual).
3. Sitting in the tractor seat, start engine. After the engine is running, move throttle control to slow position. Disengage parking brake



**CAUTION:** At any time, during step 4, there may be movement of the drive wheels.

4. Depress forward drive pedal to full forward position, hold for five (5) seconds and release pedal. Depress reverse drive pedal to full reverse position, hold for five (5) seconds and release pedal. Repeat this procedure three (3) times.
5. Shut- off engine and set parking brake.
6. Engage transmission by placing freewheel control in engaged position (See "TO TRANSPORT" in this section of manual).
7. Sitting in the tractor seat, start engine. After the engine is running, move throttle control to half (1/2) speed. Disengage parking brake.
8. Drive tractor forward for approximately five feet then backwards for five feet. Repeat this driving procedure three times.

Your transmission is now purged and now ready for normal operation.

## MOWING TIPS

- Mower should be properly leveled for best mowing performance. See "TO LEVEL MOWER HOUSING" in the Service and Adjustments section of this manual.
- The left hand side of mower should be used for trimming.
- Drive so that clippings are discharged onto the area that has been cut. Have the cut area to the right of the machine. This will result in a more even distribution of clippings and more uniform cutting.
- When mowing large areas, start by turning to the right so that clippings will discharge away from shrubs, fences, driveways, etc. After one or two rounds, mow in the opposite direction making left hand turns until finished (See Fig. 22).

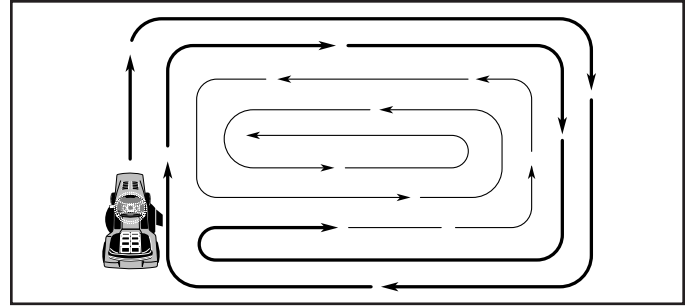

FIG. 22

- If grass is extremely tall, it should be mowed twice to reduce load and possible fire hazard from dried clippings. Make first cut relatively high; the second to the desired height.
- Do not mow grass when it is wet. Wet grass will plug mower and leave undesirable clumps. Allow grass to dry before mowing.
- **Always operate engine at full throttle when mowing** to assure better mowing performance and proper discharge of material. Regulate ground speed by selecting a low enough gear to give the mower cutting performance as well as the quality of cut desired.
- When operating attachments, select a ground speed that will suit the terrain and give best performance of the attachment being used.



# MAINTENANCE

MAINTENANCE SCHEDULE		BEFORE EACH USE	EVERY 8 HOURS	EVERY 25 HOURS	EVERY 50 HOURS	EVERY 100 HOURS	EVERY SEASON	BEFORE STORAGE
TRACTOR	Check Brake Operation	✓	✓					
	Check Tire Pressure	✓	✓					
	Check Operator Presence & ROS Systems	✓						
	Check for Loose Fasteners	✓				✓		✓
	Check/Replace Mower Blades			✓ <sub>3</sub>				
	Lubrication Chart			✓				✓
	Check Battery Level			✓ <sub>4</sub>				
	Clean Battery and Terminals			✓				✓
	Check Transaxle Cooling			✓				
	Check Mower Levelness				✓			
Check V-Belts					✓			
ENGINE	Check Engine Oil Level	✓	✓					
	Change Engine Oil (with oil filter)				✓ <sub>1,2</sub>			✓
	Change Engine Oil (without oil filter)			✓ <sub>1,2</sub>				✓
	Clean Air Filter			✓ <sub>2</sub>				
	Clean Air Screen			✓ <sub>2</sub>				
	Inspect Muffler/Spark Arrester				✓			
	Replace Oil Filter (If equipped)					✓ <sub>1,2</sub>		
	Clean Engine Cooling Fins					✓ <sub>2</sub>		
	Replace Spark Plug					✓	✓	
	Replace Air Filter Paper Cartridge					✓ <sub>2</sub>		
Replace Fuel Filter						✓		

- 1 - Change more often when operating under a heavy load or in high ambient temperatures.  
 2 - Service more often when operating in dirty or dusty conditions.

- 3 - Replace blades more often when mowing in sandy soil.  
 4 - Not required if equipped with maintenance-free battery.

maint\_sch-tractor.ROS e

## GENERAL RECOMMENDATIONS

The warranty on this tractor does not cover items that have been subjected to operator abuse or negligence. To receive full value from the warranty, operator must maintain tractor as instructed in this manual.

Some adjustments will need to be made periodically to properly maintain your tractor.

At least once a season, check to see if you should make any of the adjustments described in the Service and Adjustments section of this manual.

- At least once a year you should replace the spark plug, clean or replace air filter, and check blades and belts for wear. A new spark plug and clean air filter assure proper air-fuel mixture and help your engine run better and last longer.

### BEFORE EACH USE

- Check engine oil level.
- Check brake operation.
- Check tire pressure.
- Check operator presence and ROS systems for proper operation.
- Check for loose fasteners.

### LUBRICATION CHART

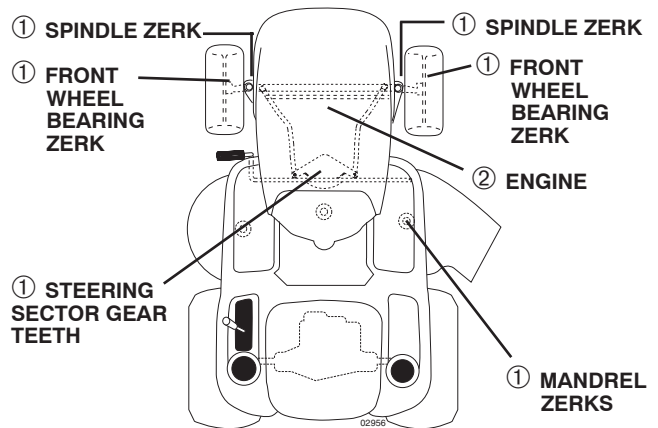

- ① General Purpose Grease  
 ② Refer to Maintenance "ENGINE" Section

**IMPORTANT:** DO NOT OIL OR GREASE THE PIVOT POINTS WHICH HAVE SPECIAL NYLON BEARINGS. VISCOUS LUBRICANTS WILL ATTRACT DUST AND DIRT THAT WILL SHORTEN THE LIFE OF THE SELF-LUBRICATING BEARINGS. IF YOU FEEL THEY MUST BE LUBRICATED, USE ONLY A DRY, POWDERED GRAPHITE TYPE LUBRICANT SPARINGLY.

# MAINTENANCE

## TRACTOR

Always observe safety rules when performing any maintenance.

### BRAKE OPERATION

If tractor requires more than five (5) feet to stop at highest speed in highest gear on a level, dry concrete or paved surface, then brake must be serviced. (See "TO CHECK BRAKE" in the Service and Adjustments section of this manual).

### TIRES

- Maintain proper air pressure in all tires (See PSI on tires).
- Keep tires free of gasoline, oil, or insect control chemicals which can harm rubber.
- Avoid stumps, stones, deep ruts, sharp objects and other hazards that may cause tire damage.

**NOTE:** To seal tire punctures and prevent flat tires due to slow leaks, tire sealant may be purchased from your local parts dealer. Tire sealant also prevents tire dry rot and corrosion.

### OPERATOR PRESENCE SYSTEM AND REVERSE OPERATION SYSTEM (ROS)

Be sure operator presence and reverse operation systems are working properly. If your tractor does not function as described, repair the problem immediately.

- The engine should not start unless the brake pedal is fully depressed, and the attachment clutch control is in the disengaged position.

#### CHECK OPERATOR PRESENCE SYSTEM

- When the engine is running, any attempt by the operator to leave the seat without first setting the parking brake should shut off the engine.
- When the engine is running and the attachment clutch is engaged, any attempt by the operator to leave the seat should shut off the engine.
- The attachment clutch should never operate unless the operator is in the seat.

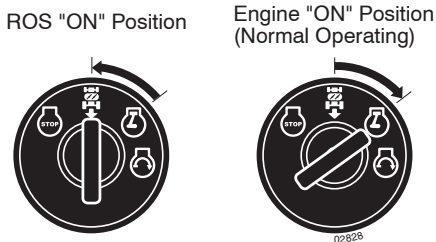

#### CHECK REVERSE OPERATION (ROS) SYSTEM

- When the engine is running with the ignition switch in the engine "ON" position and the attachment clutch engaged, any attempt by the operator to shift into reverse should shut off the engine.
- When the engine is running with the ignition switch in the ROS "ON" position and the attachment clutch engaged, any attempt by the operator to shift into reverse should NOT shut off the engine.

## BLADE CARE

For best results mower blades must be sharp. Replace worn, bent or damaged blades.



**CAUTION:** Use only a replacement blade approved by the manufacturer of your tractor. Using a blade not approved by the manufacturer of your tractor is hazardous, could damage your tractor and void your warranty.

### BLADE REMOVAL (See Fig. 23)

- Raise mower to highest position to allow access to blades.

**NOTE:** Protect your hands with gloves and/or wrap blade with heavy cloth.

- Remove blade bolt by turning counterclockwise.
- Install new blade with stamped "GRASS SIDE" facing the ground.

**IMPORTANT:** To ensure proper assembly, center hole in blade must align with star on mandrel assembly.

- Install and tighten blade bolt securely (45-55 Ft. Lbs. torque).

**IMPORTANT:** Special blade bolt is heat treated.

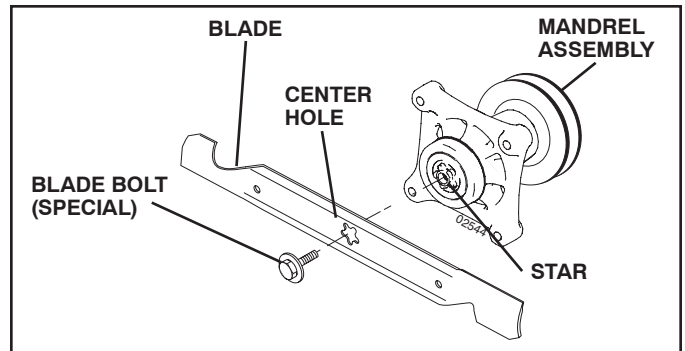

FIG. 23

## BATTERY

Your tractor has a battery charging system which is sufficient for normal use. However, periodic charging of the battery with an automotive charger will extend its life.

- Keep battery and terminals clean.
- Keep battery bolts tight.
- Keep small vent holes open.
- Recharge at 6-10 amperes for 1 hour.

**NOTE:** The original equipment battery on your tractor is maintenance free. Do not attempt to open or remove caps or covers. Adding or checking level of electrolyte is not necessary.

#### TO CLEAN BATTERY AND TERMINALS

Corrosion and dirt on the battery and terminals can cause the battery to "leak" power.

- Remove terminal guard.
- Disconnect BLACK battery cable first then RED battery cable and remove battery from tractor.

# MAINTENANCE

- Rinse the battery with plain water and dry.
- Clean terminals and battery cable ends with wire brush until bright.
- Coat terminals with grease or petroleum jelly.
- Reinstall battery (See "REPLACING BATTERY" in the SERVICE AND ADJUSTMENTS section of this manual).

## V-BELTS

Check V-belts for deterioration and wear after 100 hours of operation and replace if necessary. The belts are not adjustable. Replace belts if they begin to slip from wear.

## TRANSAXLE COOLING

The transmission fan and cooling fins should be kept clean to assure proper cooling.

Do not attempt to clean fan or transmission while engine is running or while the transmission is hot. To prevent possible damage to seals, do not use high pressure water or steam to clean transaxle.

- Inspect cooling fan to be sure fan blades are intact and clean.
- Inspect cooling fins for dirt, grass clippings and other materials. To prevent damage to seals, do not use compressed air or high pressure sprayer to clean cooling fins.

## TRANSAXLE PUMP FLUID

The transaxle was sealed at the factory and fluid maintenance is not required for the life of the transaxle. Should the transaxle ever leak or require servicing, contact your nearest authorized service center/department.

## ENGINE

### LUBRICATION

Only use high quality detergent oil rated with API service classification SG-SL. Select the oil's SAE viscosity grade according to your expected operating temperature.

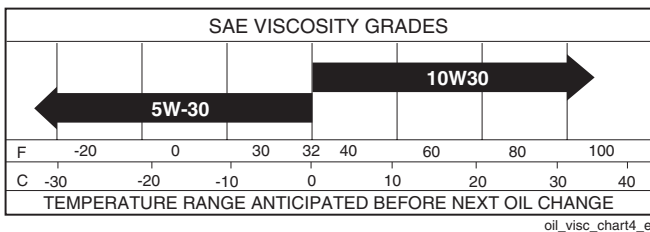

FIG. 24

Change the oil after every 50 hours of operation or at least once a year if the tractor is not used for 50 hours in one year.

Check the crankcase oil level before starting the engine and after each eight (8) hours of operation.

### TO CHANGE ENGINE OIL (See Figs. 24 and 25)

Determine temperature range expected before oil change. All oil must meet API service classification SG-SL.

- Be sure tractor is on level surface.
- Oil will drain more freely when warm.
- Catch oil in a suitable container.
- Remove oil fill cap/dipstick. Be careful not to allow dirt to enter the engine when changing oil.
- Remove yellow cap from end of drain valve and install the drain tube onto the fitting.

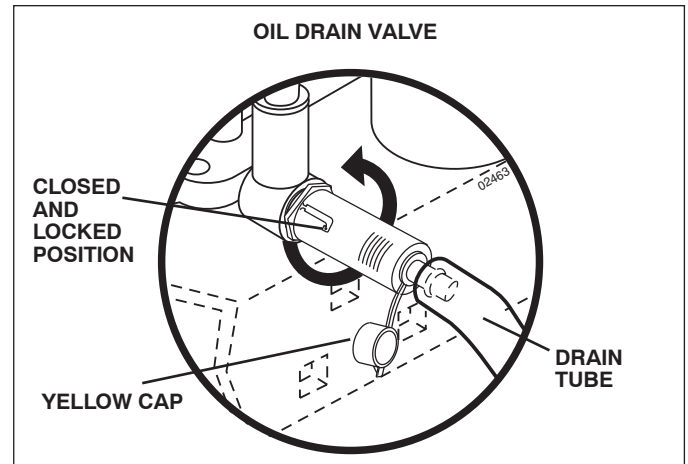

FIG. 25

- Unlock drain valve by pushing inward and turning counterclockwise.
- To open, pull out on the drain valve.
- After oil has drained completely, close and lock the drain valve by pushing inward and turning clockwise until the pin is in the locked position as shown.
- Remove the drain tube and replace the cap onto to the bottom fitting of the drain valve.
- Refill engine with oil through oil fill dipstick tube. Pour slowly. Do not overfill. For approximate capacity see "PRODUCT SPECIFICATIONS" section of this manual.
- Use gauge on oil fill cap/dipstick for checking level. Insert dipstick into the tube and rest the oil fill cap on the tube. Do not thread the cap onto the tube when taking reading. Keep oil at "FULL" line on dipstick. Tighten cap onto the tube securely when finished.

# MAINTENANCE

## CLEAN AIR SCREEN

Air screen must be kept free of dirt and chaff to prevent engine damage from overheating. Clean with a wire brush or compressed air to remove dirt and stubborn dried gum fibers.

## AIR FILTER (See Figs. 26 and 27)

Your engine will not run properly using a dirty air filter. Service paper cartridge every two months or every 25 hours of operation, whichever occurs first.

Service paper cartridge more often under dusty conditions.

Replace the paper cartridge annually, or after every 100 hours of operation.

### TO SERVICE CARTRIDGE

- Replace a dirty, bent, or damaged cartridge. Handle new cartridge carefully; do not use if the rubber seal is damaged.

**NOTE:** Do not wash the paper cartridge or use pressurized air, as this will damage the cartridge.

- Open door (A) on the blower housing to access the air cleaner element (B).
- Unhook the latch (C) and remove the element.
- Gently tap the paper element to dislodge dirt.
- Clean all air cleaner components of any accumulated dirt or foreign material. Prevent any dirt from entering the throat of carburetor.
- Install cleaned or new element on the base and secure with latch.
- Close and latch the door.

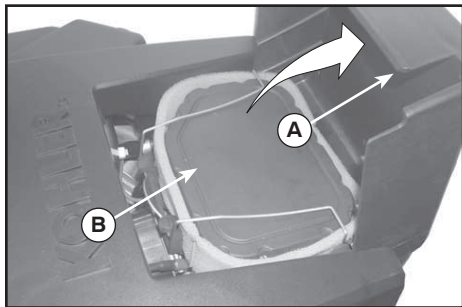

FIG. 26

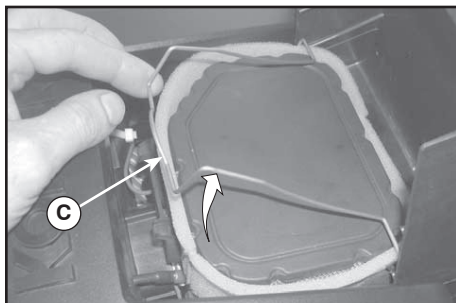

FIG. 27

## ENGINE OIL FILTER

Replace the engine oil filter every season or every other oil change if the tractor is used more than 100 hours in one year.

## CLEAN AIR INTAKE/COOLING AREAS

To insure proper cooling, make sure the grass screen, cooling fins, and other external surfaces of the engine are kept clean at all times.

Every 100 hours of operation (more often under extremely dusty, dirty conditions), remove the blower housing and other cooling shrouds. Clean the cooling fins and external surfaces as necessary. Make sure the cooling shrouds are reinstalled.

**NOTE:** Operating the engine with a blocked grass screen, dirty or plugged cooling fins, and/or cooling shrouds removed will cause engine damage due to overheating.

## MUFFLER

Inspect and replace corroded muffler and spark arrester (if equipped) as it could create a fire hazard and/or damage.

## SPARK PLUGS

Replace spark plugs at the beginning of each mowing season or after every 100 hours of operation, whichever occurs first. Spark plug type and gap setting are shown in "PRODUCT SPECIFICATIONS" section of this manual.

## IN-LINE FUEL FILTER (See Fig. 28)

The fuel filter should be replaced once each season. If fuel filter becomes clogged, obstructing fuel flow to carburetor, replacement is required.

- With engine cool, remove filter and plug fuel line sections.
- Place new fuel filter in position in fuel line with arrow pointing towards carburetor.
- Be sure there are no fuel line leaks and clamps are properly positioned.
- Immediately wipe up any spilled gasoline.

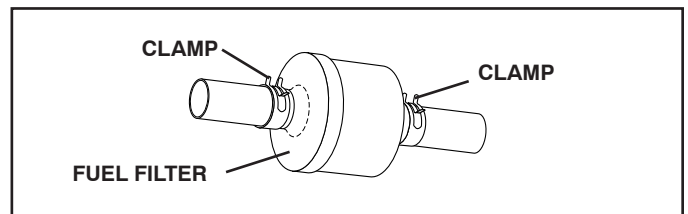

FIG. 28

## CLEANING

- Clean engine, battery, seat, finish, etc. of all foreign matter.
- Keep finished surfaces and wheels free of all gasoline, oil, etc.
- Protect painted surfaces with automotive type wax.

We do not recommend using a garden hose or pressure washer to clean your tractor unless the engine and transmission are covered to keep water out. Water in engine or transmission will shorten the useful life of your tractor. Use compressed air or a leaf blower to remove grass, leaves and trash from tractor and mower.

# SERVICE AND ADJUSTMENTS



**WARNING: TO AVOID SERIOUS INJURY, BEFORE PERFORMING ANY SERVICE OR ADJUSTMENTS:**

- Depress brake pedal fully and set parking brake.
- Place attachment clutch in “DISENGAGED” position.
- Turn ignition key to “STOP” and remove key.
- Make sure the blades and all moving parts have completely stopped.
- Disconnect spark plug wire from spark plug and place wire where it cannot come in contact with plug.

## TRACTOR (See Fig. 29)

### TO REMOVE MOWER

- Place attachment clutch in “DISENGAGED” position.
- Lower attachment lift lever to its lowest position.
- Disengage belt tension rod (K) from lock bracket (L).



**CAUTION:** Belt tension rod is spring loaded. Have a tight grip on rod and release slowly.

- Remove mower belt from electric clutch pulley (M).
- Disconnect front link (E) from mower - remove retainer spring and washer.
- Go to either side of mower and disconnect mower suspension arm (A) from chassis and rear lift link (C) from rear mower bracket (D) - remove retainer springs and washers.
- Go to other side of mower and disconnect the suspension arm and rear lift link.



**CAUTION:** After rear lift links are disconnected, the attachment lift lever will be spring loaded. Have a tight grip on lift lever when changing position of the lever.

- From right side of mower, disconnect anti-sway bar (S) from right rear mower bracket (D) - remove retainer spring and washer and pull mower toward you until the bar falls from the hole in bracket.
- Turn tractor steering wheel to the left as far as it will go.
- Slide mower out from under right side of tractor.

### TO INSTALL MOWER

Follow procedure described in “INSTALL MOWER AND DRIVE BELT” in the Assembly section of this manual.

### TO LEVEL MOWER

Make sure tires are properly inflated to the PSI shown on tires. If tires are over or under inflated, it may affect the appearance of your lawn and lead you to think the mower is not adjusted properly.

VISUAL SIDE-TO-SIDE ADJUSTMENT (See Fig. 30)

- With all tires properly inflated and if your lawn appears unevenly cut, determine which side of mower is cutting lower.

**NOTE:** As desired, you can raise the low side of mower or lower the high side.

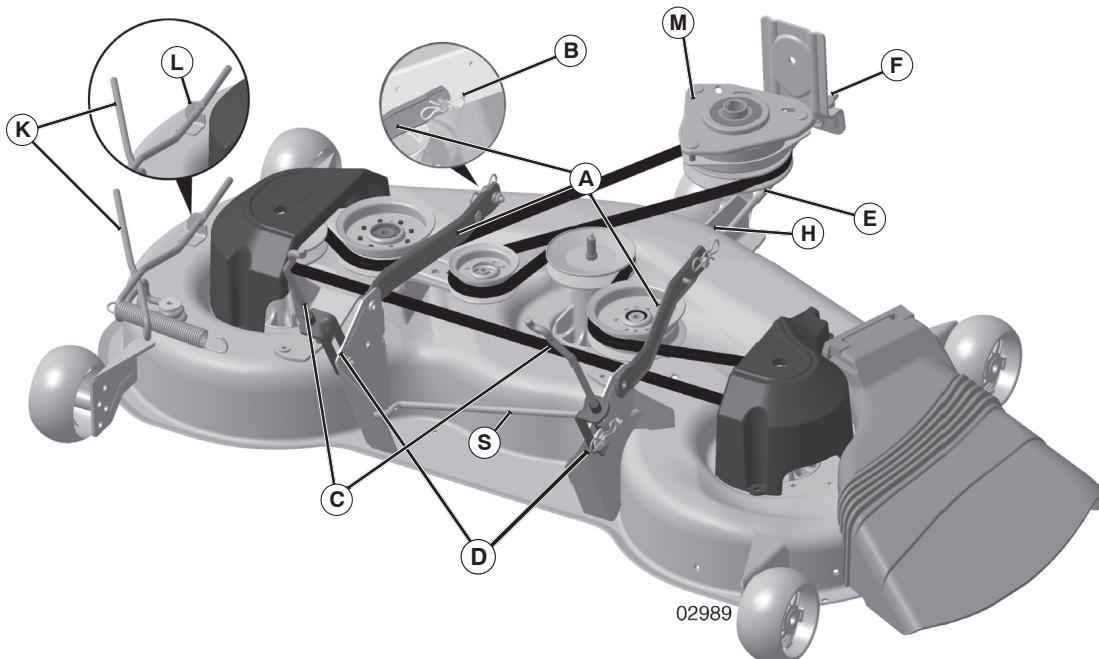

FIG. 29

# SERVICE AND ADJUSTMENTS

- Go to side of mower you wish to adjust.
- With a 3/4" or adjustable wrench, turn lift link adjustment nut (A) to the left to lower the mower, or, to the right to raise the mower.

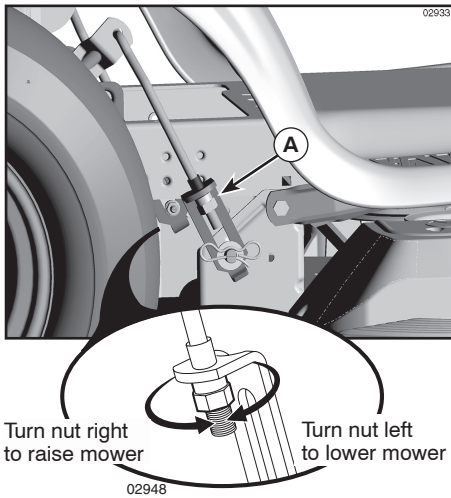

FIG. 30

**NOTE:** Each full turn of adjustment nut will change mower height about 3/16".

- Test your adjustment by mowing some uncut grass and visually checking the appearance. Readjust, if necessary, until you are satisfied with the results.

## PRECISION SIDE-TO-SIDE ADJUSTMENT

(See Fig. 31)

- With all tires properly inflated, park tractor on level ground or driveway.



**CAUTION:** Blades are sharp. Protect your hands with gloves and/or wrap blade with heavy cloth.

- Raise mower to its highest position.
- At both sides of mower, position blade at side and measure the distance (A) from bottom edge of blade to the ground. The distance should be the same on both sides.
- If adjustment is necessary, see steps 2 and 3 in Visual Adjustment instructions above.
- Recheck measurements, adjust if necessary until both sides are equal.

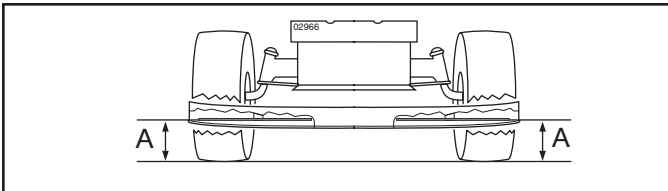

FIG. 31

FRONT-TO-BACK ADJUSTMENT (See Figs. 32 and 33)

**IMPORTANT:** Deck must be level side-to-side.

To obtain the best cutting results, the mower blades should be adjusted so the front tip is 1/8" to 1/2" lower than the rear tip when the mower is in its highest position.



**CAUTION:** Blades are sharp. Protect your hands with gloves and/or wrap blade with heavy cloth.

- Raise mower to highest position.
- Position any blade so the tip is pointing straight forward. Measure distance (B) to the ground at front and rear tip of the blade.
- If front tip of blade is not 1/8" to 1/2" lower than the rear tip, go to the front of tractor.
- With an 11/16" or adjustable wrench, loosen jam nut A several turns to clear adjustment nut B.
- With a 3/4" or adjustable wrench, turn front link adjustment nut (B) clockwise (tighten) to raise the front of mower, or, counterclockwise (loosen) to lower the front mower.

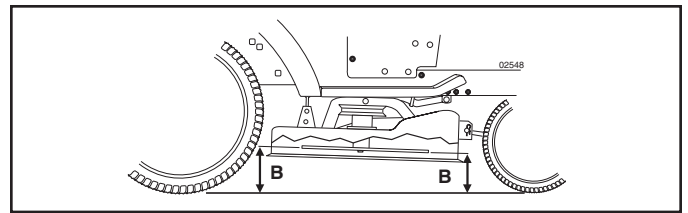
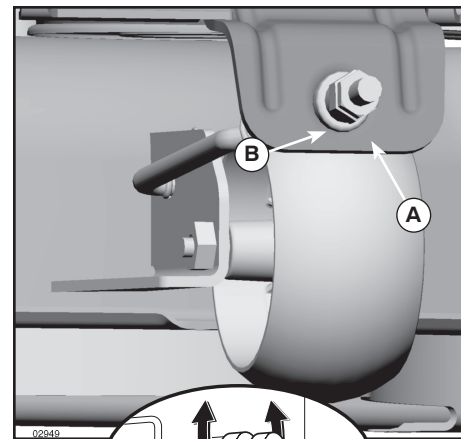

FIG. 32



Tighten adjust nut B to raise mower

Loosen adjust nut B to lower mower

Loosen jam nut A first

FIG. 33

**NOTE:** Each full turn of the adjustment nut will change mower height about 1/8".

- Recheck measurements, adjust if necessary until front tip of blade is 1/8" to 1/2" lower than the rear tip.
- Hold adjustment nut in position with wrench and tighten jam nut securely against adjustment nut.

# SERVICE AND ADJUSTMENTS

## TO REPLACE MOWER BLADE DRIVE BELT

MOWER DRIVE BELT REMOVAL (See Fig. 34)

- Park tractor on a level surface. Engage parking brake.
- Lower attachment lift lever to its lowest position.
- Disengage belt tension rod (K) from lock bracket (L).



**CAUTION: Belt tension rod is spring loaded. Have a firm grip on rod and release slowly.**

- Remove screws (P) from mandrel covers (Q) and remove covers.
- Remove any dirt or grass clippings which may have accumulated around mandrels and entire upper deck surface.
- Remove belt from electric clutch pulley (M), both mandrel pulleys (R) and all idler pulleys (S).

MOWER DRIVE BELT INSTALLATION

- Install belt around all mandrel pulleys (R) and around idler pulleys (S) as shown.
- Install belt onto electric clutch pulley (M).

**IMPORTANT:** Check belt for proper routing in all mower pulley grooves.

- Reassemble mandrel covers (Q). Securely tighten all screws.
- Engage belt tension rod (K) on locking bracket (L).



**CAUTION: Belt tension rod is spring loaded. Have a tight grip on rod and engage slowly.**

- Raise attachment lift lever to highest position.

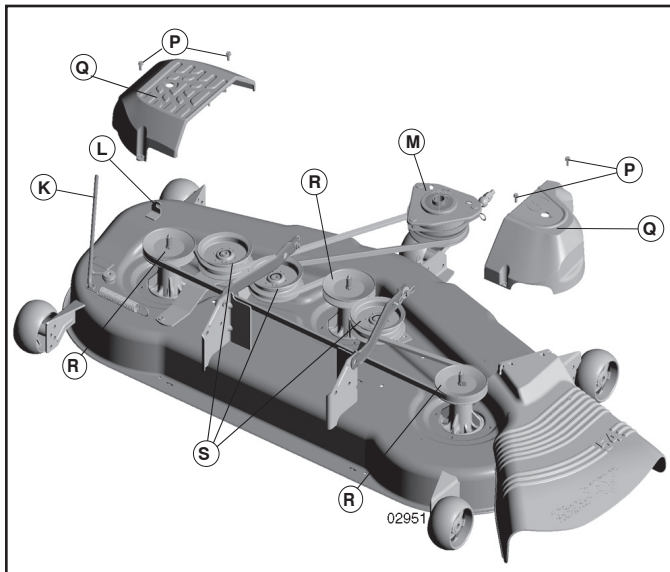

FIG. 34

## TO CHECK BRAKE

If tractor requires more than five (5) feet to stop at highest speed in highest gear on a level, dry concrete or paved surface, then brake must be serviced.

You may also check brake by:

- Park tractor on a level, dry concrete or paved surface, depress brake pedal all the way down and engage parking brake.
- Disengage transmission by placing freewheel control in "transmission disengaged" position. Pull freewheel control out and into the slot and release so it is held in the disengaged position.

The rear wheels must lock and skid when you try to manually push the tractor forward. If the rear wheels rotate, then the brake needs to be serviced. Contact a qualified service center.

## TO REPLACE MOTION DRIVE BELT (See Fig. 35)

Park the tractor on level surface. Engage parking brake. For assistance, there is a belt installation guide decal on bottom side of left footrest.

BELT REMOVAL -

- Remove mower (See "TO REMOVE MOWER" in this section of manual).

**NOTE:** Observe entire motion drive belt and position of all belt guides and keepers.

- Disconnect clutch wire harness (A).
- Remove anti-rotation link (B) on right side of tractor.
- Remove belt from stationary idler (C) and clutching idler (D).
- Remove belt from centerspan idler (E).
- Pull belt slack toward rear of tractor. Carefully remove belt upwards from transmission input pulley and over cooling fan blades (F).
- Remove belt downward from engine pulley and around electric clutch (G).
- Slide belt toward rear of tractor, off the steering plate (H) and remove from tractor.

BELT INSTALLATION -

- Install new belt from tractor rear to front, over the steering plate (H) and above clutch brake pedal shaft (J).
- Pull belt toward front of tractor and roll belt around electric clutch and onto engine pulley (G).
- Pull belt toward rear of tractor. Carefully work belt down around transmission cooling fan and onto the input pulley (F). Be sure belt is inside the belt keeper.
- Install belt on centerspan idler (E).
- Install belt through stationary idler (C) and clutching idler (D).
- Reinstall anti-rotation link (B) on right side of tractor. Tighten securely.
- Reconnect clutch harness (A).
- Make sure belt is in all pulley grooves and inside all belt guides and keepers.
- Install mower (See "TO INSTALL MOWER" in this section of manual).

# SERVICE AND ADJUSTMENTS

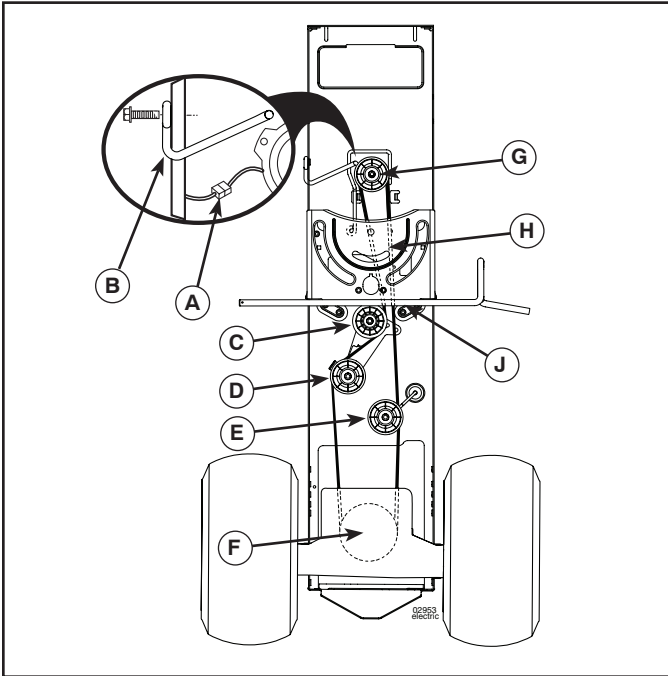

FIG. 35

## FRONT WHEEL TOE-IN/CAMBER

Your new tractor front wheel toe-in and camber is set at the factory and is normal. The front wheel toe-in and camber are not adjustable. If damage has occurred to affect the factory set front wheel toe-in or camber, contact a qualified service center.

## TO REMOVE WHEEL FOR REPAIRS (See Fig. 36)

- Block up axle securely.
- Remove axle cover, retaining ring and washers to allow wheel removal (rear wheel contains a square key - Do not lose).
- Repair tire and reassemble.
- On rear wheels only: align grooves in rear wheel hub and axle. Insert square key.
- Replace washers and snap retaining ring securely in axle groove.
- Replace axle cover.

**NOTE:** To seal tire punctures and prevent flat tires due to slow leaks, tire sealant may be purchased from your local parts dealer. Tire sealant also prevents tire dry rot and corrosion.

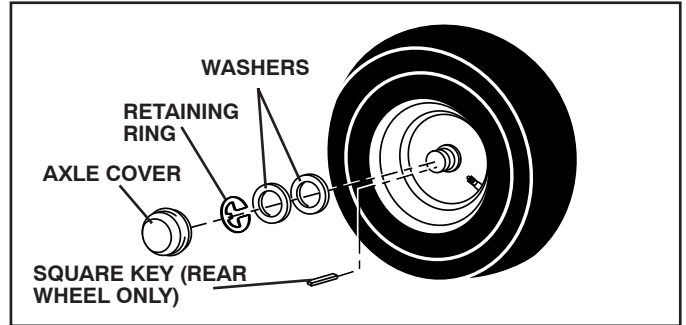

FIG. 36

## TO START ENGINE WITH A WEAK BATTERY (See Fig. 37)



**WARNING:** Lead-acid batteries generate explosive gases. Keep sparks, flame and smoking materials away from batteries. Always wear eye protection when around batteries.

If your battery is too weak to start the engine, it should be recharged. (See "BATTERY" in the MAINTENANCE section of this manual).

If "jumper cables" are used for emergency starting, follow this procedure:

**IMPORTANT:** YOUR TRACTOR IS EQUIPPED WITH A 12 VOLT SYSTEM. THE OTHER VEHICLE MUST ALSO BE A 12 VOLT SYSTEM. DO NOT USE YOUR TRACTOR BATTERY TO START OTHER VEHICLES.

### TO ATTACH JUMPER CABLES -

- Connect one end of the RED cable to the POSITIVE (+) terminal of each battery (A-B), taking care not to short against tractor chassis.
- Connect one end of the BLACK cable to the NEGATIVE (-) terminal (C) of fully charged battery.
- Connect the other end of the BLACK cable (D) to good chassis ground, away from fuel tank and battery.

### TO REMOVE CABLES, REVERSE ORDER -

- BLACK cable first from chassis and then from the fully charged battery.
- RED cable last from both batteries.

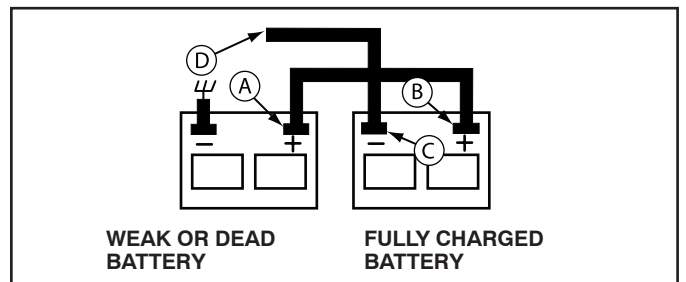

FIG. 37



---

# SERVICE AND ADJUSTMENTS

---

## TO REPLACE HEADLIGHT BULB

- Raise hood.
- Pull bulb holder out of the hole in the backside of the grill.
- Replace bulb in holder and push bulb holder securely back into the hole in the backside of the grill.
- Close hood.

## INTERLOCKS AND RELAYS

Loose or damaged wiring may cause your tractor to run poorly, stop running, or prevent it from starting.

- Check wiring. See electrical wiring diagram in the Repair Parts section.

## TO REPLACE FUSE

Replace with 20 amp automotive-type plug-in fuse. The fuse holder is located behind the dash.

## TO REMOVE HOOD AND GRILL ASSEMBLY (See Fig. 38)

- Raise hood.
- Unsnap headlight wire connector.
- Stand in front of tractor. Grasp hood at sides, tilt toward engine and lift off of tractor.
- To replace, reverse above procedure.

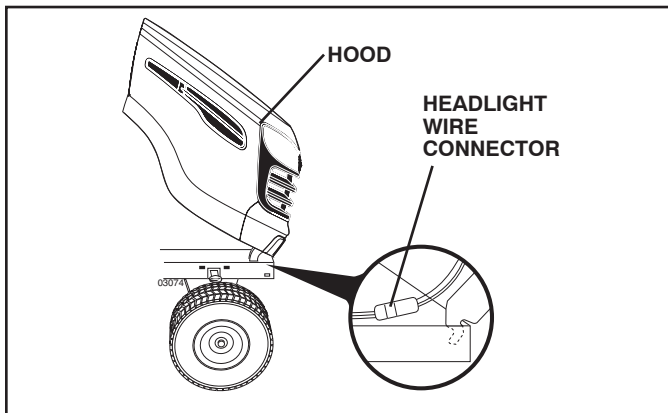

FIG. 38

## ENGINE

### TO ADJUST THROTTLE CONTROL CABLE

The throttle control has been preset at the factory and adjustment should not be necessary. If adjustment is necessary, see engine manual.

### TO ADJUST CHOKE CONTROL

The choke control has been preset at the factory and adjustment should not be necessary. If adjustment is necessary, see engine manual.

### TO ADJUST CARBURETOR

Your carburetor is not adjustable. If your engine does not operate properly due to suspected carburetor problems, take your tractor to an authorized service center for repair and/or adjustment.

---

# STORAGE

---

Immediately prepare your tractor for storage at the end of the season or if the tractor will not be used for 30 days or more.



**WARNING: Never store the tractor with gasoline in the tank inside a building where fumes may reach an open flame or spark. Allow the engine to cool before storing in any enclosure.**

## TRACTOR

Remove mower from tractor for winter storage. When mower is to be stored for a period of time, clean it thoroughly, remove all dirt, grease, leaves, etc. Store in a clean, dry area.

- Clean entire tractor (See “CLEANING” in the Maintenance section of this manual).
- Inspect and replace belts, if necessary (See belt replacement instructions in the Service and Adjustments section of this manual).
- Lubricate as shown in the Maintenance section of this manual.
- Be sure that all nuts, bolts and screws are securely fastened. Inspect moving parts for damage, breakage and wear. Replace if necessary.
- Touch up all rusted or chipped paint surfaces; sand lightly before painting.

## BATTERY

- Fully charge the battery for storage.
- After a period of time in storage, battery may require recharging.
- To help prevent corrosion and power leakage during long periods of storage, battery cables should be disconnected and battery cleaned thoroughly (see “TO CLEAN BATTERY AND TERMINALS” in the Maintenance section of this manual).
- After cleaning, leave cables disconnected and place cables where they cannot come in contact with battery terminals.
- If battery is removed from tractor for storage, do not store battery directly on concrete or damp surfaces.

## ENGINE

### FUEL SYSTEM

**IMPORTANT:** IT IS IMPORTANT TO PREVENT GUM DEPOSITS FROM FORMING IN ESSENTIAL FUEL SYSTEM PARTS SUCH AS CARBURETOR, FUEL FILTER, FUEL HOSE, OR TANK DURING STORAGE. ALSO, EXPERIENCE INDICATES THAT ALCOHOL BLENDED FUELS (CALLED GASOHOL OR USING ETHANOL OR METHANOL) CAN ATTRACT MOISTURE WHICH LEADS TO SEPARATION AND FORMATION OF ACIDS DURING STORAGE. ACIDIC GAS CAN DAMAGE THE FUEL SYSTEM OF AN ENGINE WHILE IN STORAGE.

- Empty the fuel tank by starting the engine and let it run until the fuel lines and carburetor are empty.
- Never use engine or carburetor cleaner products in the fuel tank or permanent damage may occur.
- Use fresh fuel next season.

**NOTE:** Fuel stabilizer is an acceptable alternative in minimizing the formation of fuel gum deposits during storage. Add stabilizer to gasoline in fuel tank or storage container. Always follow the mix ratio found on stabilizer container. Run engine at least 10 minutes after adding stabilizer to allow the stabilizer to reach the carburetor. Do not empty the gas tank and carburetor if using fuel stabilizer.

### ENGINE OIL

Drain oil (with engine warm) and replace with clean engine oil. (See “ENGINE” in the Maintenance section of this manual).

### CYLINDER(S)

- Remove spark plug(s).
- Pour one ounce of oil through spark plug hole(s) into cylinder(s).
- Turn ignition key to “START” position for a few seconds to distribute oil.
- Replace with new spark plug(s).

### OTHER

- Do not store gasoline from one season to another.
- Replace your gasoline can if your can starts to rust. Rust and/or dirt in your gasoline will cause problems.
- If possible, store your tractor indoors and cover it to give protection from dust and dirt.
- Cover your tractor with a suitable protective cover that does not retain moisture. Do not use plastic. Plastic cannot breathe which allows condensation to form and will cause your tractor to rust.

**IMPORTANT:** NEVER COVER TRACTOR WHILE ENGINE AND EXHAUST AREAS ARE STILL WARM.

# TROUBLESHOOTING POINTS

PROBLEM	CAUSE	CORRECTION
<b>Will not start</b>	<ol style="list-style-type: none"> <li>1. Out of fuel.</li> <li>2. Engine not "CHOKED" properly.</li> <li>3. Engine flooded.</li> <li>4. Bad spark plug.</li> <li>5. Weak or dead battery.</li> <li>6. Dirty air filter.</li> <li>7. Dirty fuel filter.</li> <li>8. Water in fuel.</li> <li>9. Loose or damaged wiring.</li> <li>10. Carburetor out of adjustment.</li> <li>11. Engine valves out of adjustment.</li> </ol>	<ol style="list-style-type: none"> <li>1. Fill fuel tank.</li> <li>2. See "TO START ENGINE" in Operation section.</li> <li>3. Wait several minutes before attempting to start.</li> <li>4. Replace spark plug.</li> <li>5. Recharge or replace battery.</li> <li>6. Clean/replace air filter.</li> <li>7. Replace fuel filter.</li> <li>8. Empty fuel tank and carburetor, refill tank with fresh gasoline and replace fuel filter.</li> <li>9. Check all wiring.</li> <li>10. See "To Adjust Carburetor" in Service Adjustments section.</li> <li>11. Contact an authorized service center/department.</li> </ol>
<b>Hard to start</b>	<ol style="list-style-type: none"> <li>1. Dirty air filter.</li> <li>2. Bad spark plug.</li> <li>3. Weak or dead battery.</li> <li>4. Dirty fuel filter.</li> <li>5. Stale or dirty fuel.</li> <li>6. Loose or damaged wiring.</li> <li>7. Carburetor out of adjustment.</li> <li>8. Engine valves out of adjustment.</li> </ol>	<ol style="list-style-type: none"> <li>1. Clean/replace air filter.</li> <li>2. Replace spark plug.</li> <li>3. Recharge or replace battery.</li> <li>4. Replace fuel filter.</li> <li>5. Empty fuel tank and refill tank with fresh, clean gasoline.</li> <li>6. Check all wiring.</li> <li>7. See "To Adjust Carburetor" in Service Adjustments section.</li> <li>8. Contact an authorized service center/department.</li> </ol>
<b>Engine will not turn over</b>	<ol style="list-style-type: none"> <li>1. Brake pedal not depressed.</li> <li>2. Attachment clutch is engaged.</li> <li>3. Weak or dead battery.</li> <li>4. Blown fuse.</li> <li>5. Corroded battery terminals.</li> <li>6. Loose or damaged wiring.</li> <li>7. Faulty ignition switch.</li> <li>8. Faulty solenoid or starter.</li> <li>9. Faulty operator presence switch(es).</li> </ol>	<ol style="list-style-type: none"> <li>1. Depress brake pedal.</li> <li>2. Disengage attachment clutch.</li> <li>3. Recharge or replace battery.</li> <li>4. Replace fuse.</li> <li>5. Clean battery terminals.</li> <li>6. Check all wiring.</li> <li>7. Check/replace ignition switch.</li> <li>8. Check/replace solenoid or starter.</li> <li>9. Contact an authorized service center/department.</li> </ol>
<b>Engine clicks but will not start</b>	<ol style="list-style-type: none"> <li>1. Weak or dead battery.</li> <li>2. Corroded battery terminals.</li> <li>3. Loose or damaged wiring.</li> <li>4. Faulty solenoid or starter.</li> </ol>	<ol style="list-style-type: none"> <li>1. Recharge or replace battery.</li> <li>2. Clean battery terminals.</li> <li>3. Check all wiring.</li> <li>4. Check/replace solenoid or starter.</li> </ol>
<b>Loss of power</b>	<ol style="list-style-type: none"> <li>1. Cutting too much grass/too fast.</li> <li>2. Throttle in "CHOKE" position.</li> <li>3. Build-up of grass, leaves and trash under mower.</li> <li>4. Dirty air filter.</li> <li>5. Low oil level/dirty oil.</li> <li>6. Faulty spark plug.</li> <li>7. Dirty fuel filter.</li> <li>8. Stale or dirty fuel.</li> <li>9. Water in fuel.</li> <li>10. Spark plug wire loose.</li> <li>11. Dirty engine air screen/fins.</li> <li>12. Dirty/clogged muffler.</li> <li>13. Loose or damaged wiring.</li> <li>14. Carburetor out of adjustment.</li> <li>15. Engine valves out of adjustment.</li> </ol>	<ol style="list-style-type: none"> <li>1. Raise cutting height/reduce speed.</li> <li>2. Adjust throttle control.</li> <li>3. Clean underside of mower housing.</li> <li>4. Clean/replace air filter.</li> <li>5. Check oil level/change oil.</li> <li>6. Clean and regap or change spark plug.</li> <li>7. Replace fuel filter.</li> <li>8. Empty fuel tank and refill tank with fresh, clean gasoline.</li> <li>9. Empty fuel tank and carburetor, refill tank with fresh gasoline and replace fuel filter.</li> <li>10. Connect and tighten spark plug wire.</li> <li>11. Clean engine air screen/fins.</li> <li>12. Clean/replace muffler.</li> <li>13. Check all wiring.</li> <li>14. See "To Adjust Carburetor" in Service Adjustments section.</li> <li>15. Contact an authorized service center/department.</li> </ol>
<b>Excessive vibration</b>	<ol style="list-style-type: none"> <li>1. Worn, bent or loose blade.</li> <li>2. Bent blade mandrel.</li> <li>3. Loose/damaged part(s).</li> </ol>	<ol style="list-style-type: none"> <li>1. Replace blade. Tighten blade bolt.</li> <li>2. Replace blade mandrel.</li> <li>3. Tighten loose part(s). Replace damaged parts.</li> </ol>

# TROUBLESHOOTING POINTS

PROBLEM	CAUSE	CORRECTION
<b>Engine dies when tractor is shifted into reverse</b>	<ol style="list-style-type: none"> <li>Reverse operation system (ROS) is not "ON" while mower or other attachment is engaged.</li> </ol>	<ol style="list-style-type: none"> <li>Turn ignition key to ROS "ON" position. See Operation section.</li> </ol>
<b>Engine continues to run when operator leaves seat with attachment clutch engaged</b>	<ol style="list-style-type: none"> <li>Faulty operator-safety presence control system.</li> </ol>	<ol style="list-style-type: none"> <li>Check wiring, switches and connections. If not corrected, contact an authorized service center/department.</li> </ol>
<b>Poor cut - uneven</b>	<ol style="list-style-type: none"> <li>Worn, bent or loose blade.</li> <li>Mower deck not level.</li> <li>Buildup of grass, leaves, and trash under mower.</li> <li>Bent blade mandrel.</li> <li>Clogged mower deck vent holes from buildup of grass, leaves, and trash around mandrels.</li> </ol>	<ol style="list-style-type: none"> <li>Replace blade. Tighten blade bolt.</li> <li>Level mower deck.</li> <li>Clean underside of mower housing.</li> <li>Replace blade mandrel.</li> <li>Clean around mandrels to open vent holes.</li> </ol>
<b>Mower blades will not rotate</b>	<ol style="list-style-type: none"> <li>Obstruction in clutch mechanism.</li> <li>Worn/damaged mower drive belt.</li> <li>Frozen idler pulley.</li> <li>Frozen blade mandrel.</li> </ol>	<ol style="list-style-type: none"> <li>Remove obstruction.</li> <li>Replace mower drive belt.</li> <li>Replace idler pulley.</li> <li>Replace blade mandrel.</li> </ol>
<b>Poor grass discharge</b>	<ol style="list-style-type: none"> <li>Engine speed too slow.</li> <li>Travel speed too fast.</li> <li>Wet grass.</li> <li>Mower deck not level.</li> <li>Low/uneven tire air pressure.</li> <li>Worn, bent or loose blade.</li> <li>Buildup of grass, leaves and trash under mower.</li> <li>Mower drive belt worn.</li> <li>Blades improperly installed.</li> <li>Improper blades used.</li> <li>Clogged mower deck vent holes from buildup of grass, leaves, and trash around mandrels.</li> </ol>	<ol style="list-style-type: none"> <li>Place throttle control in "FAST" position.</li> <li>Shift to slower speed.</li> <li>Allow grass to dry before mowing.</li> <li>Level mower deck.</li> <li>Check tires for proper air pressure.</li> <li>Replace blade. Tighten blade bolt.</li> <li>Clean underside of mower housing.</li> <li>Replace mower drive belt.</li> <li>Reinstall blades sharp edge down.</li> <li>Replace with blades listed in this manual.</li> <li>Clean around mandrels to open vent holes.</li> </ol>
<b>Headlight(s) not working (if so equipped)</b>	<ol style="list-style-type: none"> <li>Light switch is "OFF".</li> <li>Bulb(s) or lamp(s) burned out.</li> <li>Faulty light switch.</li> <li>Loose or damaged wiring.</li> <li>Blown fuse.</li> </ol>	<ol style="list-style-type: none"> <li>Turn light switch "ON".</li> <li>Replace bulb(s) or lamp(s).</li> <li>Check/replace light switch.</li> <li>Check wiring and connections.</li> <li>Replace fuse.</li> </ol>
<b>Battery will not charge</b>	<ol style="list-style-type: none"> <li>Bad battery cell(s).</li> <li>Poor cable connections.</li> <li>Faulty regulator (if so equipped).</li> <li>Faulty alternator.</li> </ol>	<ol style="list-style-type: none"> <li>Replace battery.</li> <li>Check/clean all connections.</li> <li>Replace regulator.</li> <li>Replace alternator.</li> </ol>
<b>Loss of drive</b>	<ol style="list-style-type: none"> <li>Freewheel control in "disengaged" position.</li> <li>Motion drive belt worn, damaged, or broken.</li> <li>Air trapped in transmission during shipment or servicing.</li> </ol>	<ol style="list-style-type: none"> <li>Place freewheel control in "engaged" position.</li> <li>Replace motion drive belt.</li> <li>Purge transmission.</li> </ol>
<b>Engine "backfires" when turning engine "OFF"</b>	<ol style="list-style-type: none"> <li>Engine throttle control not set between half and full speed (fast) position before stopping engine.</li> </ol>	<ol style="list-style-type: none"> <li>Move throttle control between half and full speed (fast) position before stopping engine.</li> </ol>

# TRACTOR -- MODEL NUMBER 944.606092

## SCHEMATIC

02929-194276\_Regulated-Tex

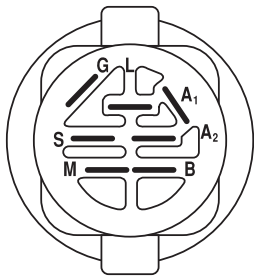
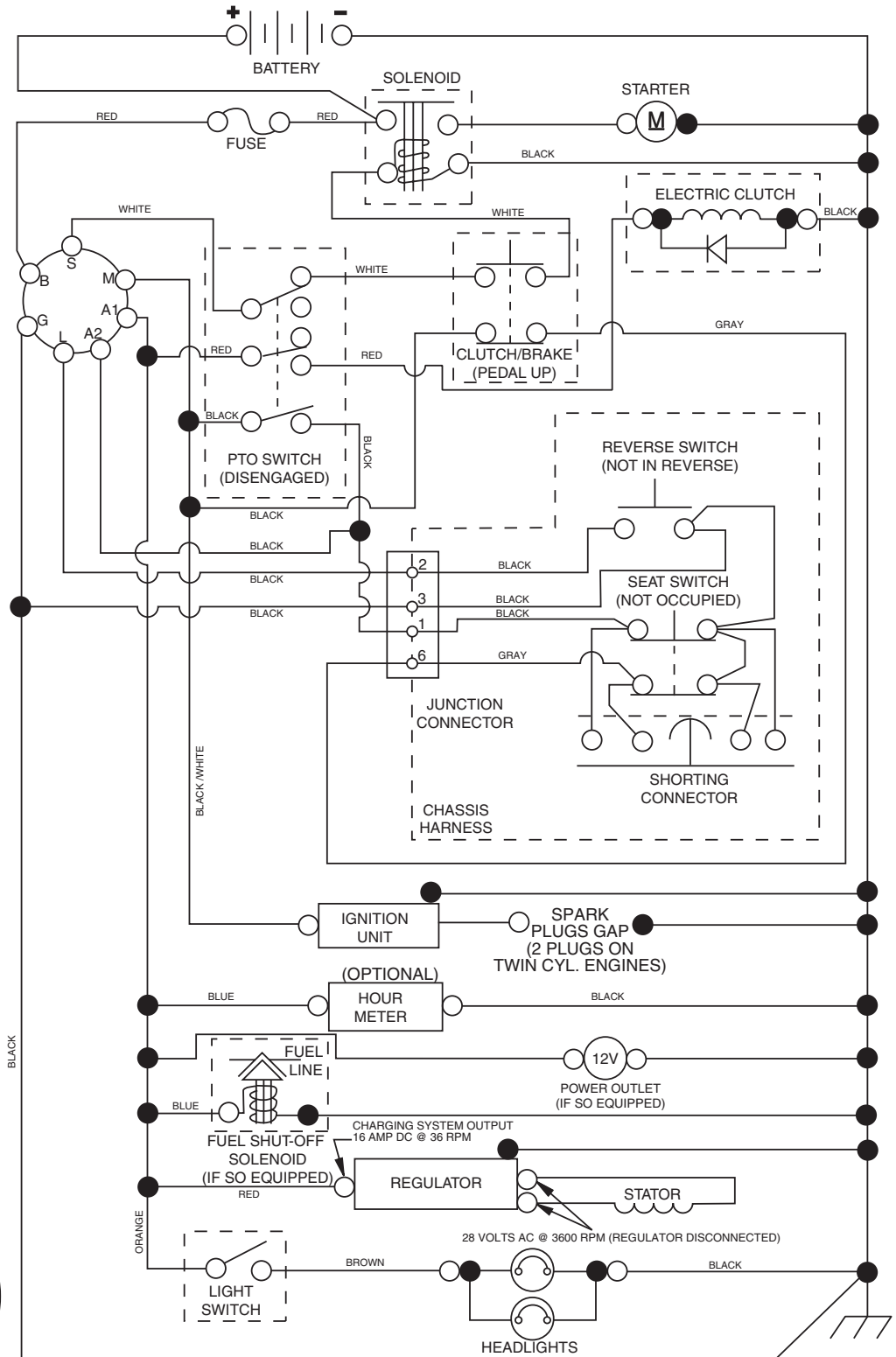

**IGNITION SWITCH**

POSITION	CIRCUIT	"MAKE"
OFF	M+G+A1	
RUN/OVERRIDE	B+A1	
RUN	B+A1	L+A2
START	B + S + A1	

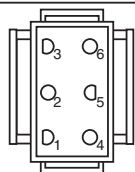

CHASSIS HARNESS CONNECTOR (MATING SIDE)

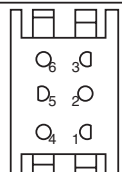

DASH HARNESS CONNECTOR (MATING SIDE)

**WIRING INSULATED CLIPS**  
**NOTE:** IF WIRING INSULATED CLIPS WERE REMOVED FOR SERVICING OF UNIT, THEY SHOULD BE REPLACED TO PROPERLY SECURE YOUR WIRING.

●  
NON-REMOVABLE CONNECTIONS

○  
REMOVABLE CONNECTIONS

02929

# TRACTOR - - MODEL NUMBER 944.606092

## ELECTRICAL

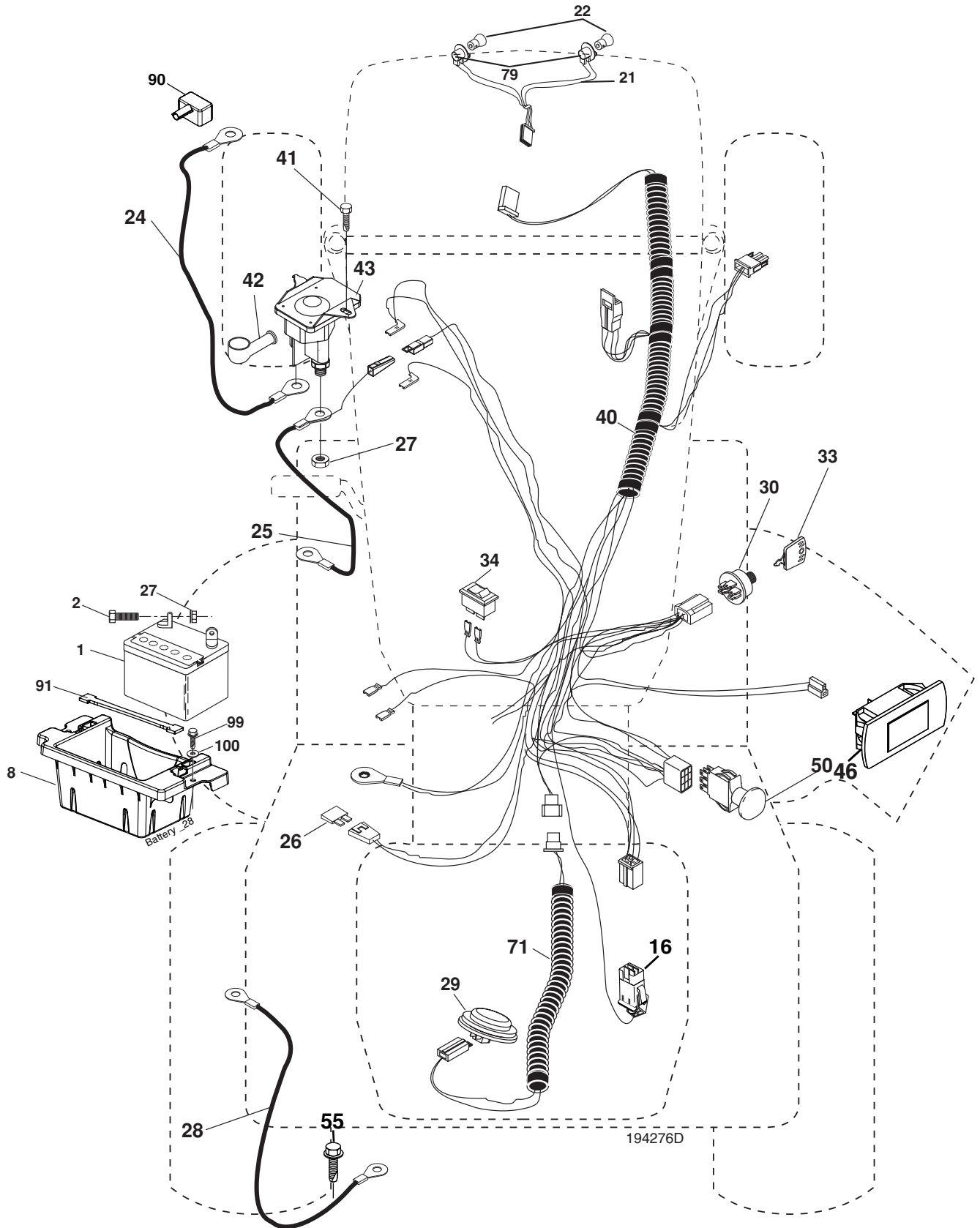

**VGT Comm. Harn. 194276D**

# TRACTOR - - MODEL NUMBER 944.606092

## ELECTRICAL

KEY NO.	PART NO.	DESCRIPTION
1	144927	Battery
2	74760412	Bolt Hex Head 1/4-20 x 3/4
8	186491	Box Battery
16	176138	Switch Interlock Push-In
21	400252	Harness Socket Light W/4152J
22	4152J	Bulb Light
24	400253	Cable Battery
25	198893	Cable Start Red
26	175158	Fuse
27	73510400	Nut Keps Hex 1/4-20 unc
28	145491	Cable, Ground
29	401545	Switch, Seat
30	193350	Switch, Ignition
33	140403	Key, Ignition
34	110712X	Switch Light / Reset
40	401105	Harness Ign. Dash
41	17720408	Screw Thd Cut 1/4-20 x 1/2
42	131563	Cover, Terminal
43	192507	Solenoid
46	198138	Gauge Hourmeter
50	174652	Switch, PTO
55	17490508	Screw Thdrol 5/16-18 x 1/2 TYTT
71	194276	Harness Ignition
79	175242	Bulbholder Asm. Incan Descent
90	400724	Cover Terminal Battery
91	190270	Strap Battery Mount Front
99	17670412	Screw Hexwsh Thdrol 1/4-20 x 3/4
100	19091416	Washer 9/32 x 7/8 x 16 Ga.

**NOTE:** All component dimensions given in U.S. inches  
1 inch = 25.4 mm

# TRACTOR - - MODEL NUMBER 944.606092

## CHASSIS

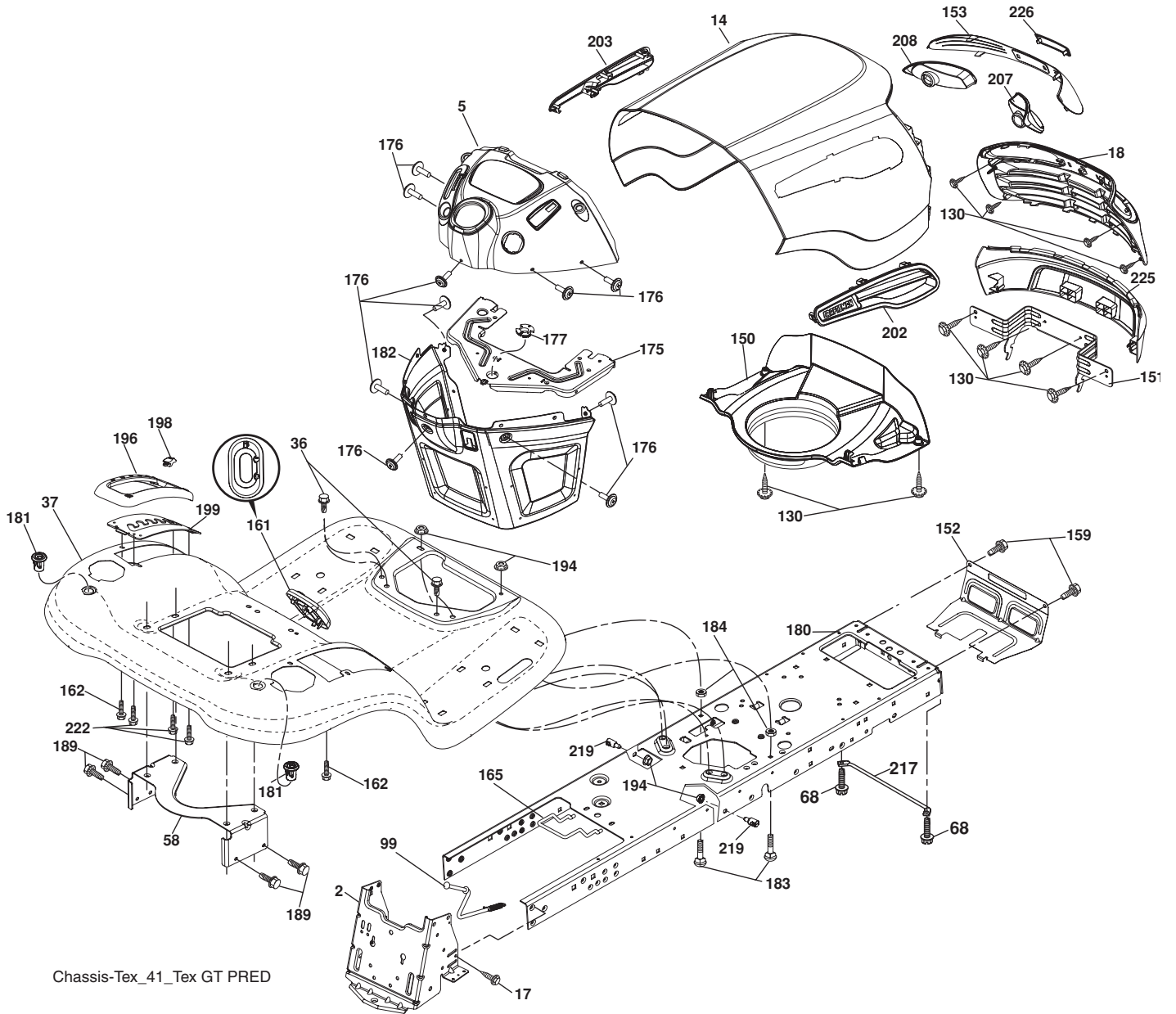

Chassis-Tex\_41\_Tex GT PRED



# TRACTOR - - MODEL NUMBER 944.606092

## CHASSIS

KEY NO.	PART NO.	DESCRIPTION
2	194261	Drawbar
5	199675X428	Dash
14	404654X428	Hood
17	17060612	Screw 3/8-16 x .75
18	404625	Grille
36	17060512	Screw 5/16-18 x 3/4
37	400009X428	Fender
58	194314	Bracket Fender
68	17490508	Screw Thdrol 5/16-18 x 1/2
99	197273	Rod Bypass Asm.
130	191611	Screw 10 x 3/4 Single Lead-Hex
150	199411	Duct Heat Hood
151	196332	Bracket Pivot
152	194329	Shield Browning/Debris
153	198965	Lens Bar
159	17000612	Screw Hexwsh Thdrol 3/8-16 x 3/4
161	193097X428	Console Fuel Window
162	142432	Screw Hex Wsh Hi-Lo 1/4 x 1/2
165	194330	Bracket Support Tank
175	196304	Crossmember
176	400776	Screw #10-24 x 5/8 Rnd Qudrx
177	195227	Bushing Steering
180	194260	Chassis
181	193102X428	Bushing Mtg. Fender Crgo.
182	194787	Dash Lower
183	74780520	Bolt Fin Hex 5/16-18UNC x 1-1/4
184	195780	Spacer Fender
189	17000512	Screw 5/16-18 x 3/4
194	73900500	Nut Lock Hex Flange 5/16-18
196	193098X428	Console Asm. Deck Lift
198	197300X505	Indicator Deck Lift
199	196377	Plate Deck Lift
202	198968X428	Vent Side Hood RH
203	198969X428	Vent Side Hood LH
207	198963	Bezel RH
208	198964	Bezel LH
217	156524	Rod Pivot
219	195161	Stud Fastener
222	137729	Screw thd Roll 1/4-20 x 5/8
225	198962X428	Bumper
226	198967X428	Logo

**NOTE:** All component dimensions given in U.S. inches  
1 inch = 25.4 mm

# TRACTOR - - MODEL NUMBER 944.606092

## DRIVE

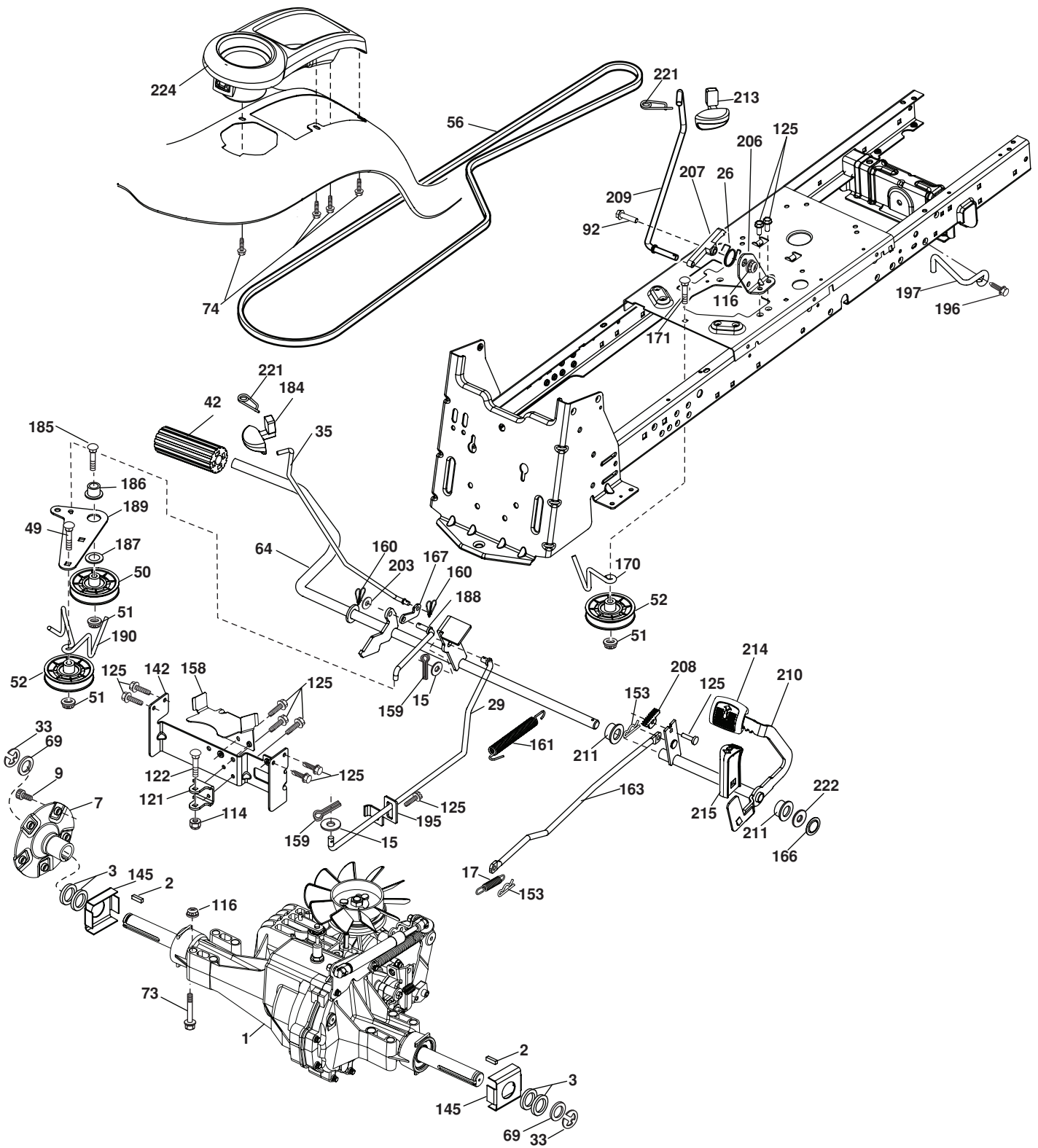

drive-tex\_22-HG 3000

## TRACTOR - - MODEL NUMBER 944.606092

### DRIVE

KEY NO.	PART NO.	DESCRIPTION	KEY NO.	PART NO.	DESCRIPTION
1	-----	Transaxle, Hydro 347-3000 (See Transaxle Breakdown)	160	169484	Retainer Clip
2	7070E	Key 1/4 x 2.500	161	195403	Spring, Return, Clutch
3	7563R	Washer Thrust	163	197870	Rod Control Pedal
7	199837	Hub Asm. Wheel	166	197290	Nut Push .625
9	140080	Bolt Hub Wheel	167	196211	Latch Brake Parking
15	19131316	Washer 13/32 x 13/16 x 16 Ga.	170	194322	Keeper Belt Centerspan
17	197296	Spring, Brake	171	72110616	Bolt
26	199679	Spring Return Cruise	184	196439X505	Handle Parking Brake
29	197269	Rod, Brake	185	72110620	Bolt
33	12000053	Ring E #5133-100	186	194321	Spacer Retainer
35	199591	Rod, Brake, Park	187	19133210	Washer
42	8883R	Cover, Foot Pedal	188	194323	Link Clutch Ground Drive
49	72110614	Bolt	189	194317	Bellcrank Ground Drive
50	194327	Pulley Idler Flat	190	194318	Keeper Bellcrank Ground Drive
51	73900600	Lock Nut 3/8-16	195	197331	Bracket Rod Brake
52	194326	Idler V-Groove 910" Offset	196	17000616	Screw 3/8-16 x 1
56	165813	V-Belt, Drive	197	199769	Bracket Clutch Anti-Rotation
64	197865	Shaft Asm. Pedal Brake Control	203	19111116	Washer 11/32 x 11/16 x 16 Ga.
69	123800X	Washer 1-1/32 x 1-5/8 x 16 Ga.	206	197867	Bracket Mount Latch Cruise
73	74490548	Bolt Hex Flghd 5/16-18 x 3.0 Gr. 5	207	197868	Latch Control Cruise
74	142432	Screw 1/4 x 1/2	208	197869	Gear Sector Control Cruise
92	74760520	Bolt Fin Hex 5/16-18 unc x 1.25	209	199592	Rod Control Cruise
114	73800500	Nut Lock Hex W/Ins. 5/16-18 unc	210	197860	Rocker Asm. Pedal Control
116	73900500	Nut Lock Hex Flange 5/16-18	211	120183X	Bearing Nylon Blk .629
121	175611	Bracket Strap Torque	213	196441X428	Knob Control Cruise
122	72010520	Bolt 5/16-18 x 2.50	214	197302X428	Pedal Forward
125	17000512	Screw 5/16-18 x 3/4	215	197301X428	Pedal Reverse
142	404483	Strap Torque	221	403187	Retainer Spring Clip Handle
145	163168	Washer Axle Flange	222	19212010	Washer 21/32 x 1-1/4 x 10 Ga.
153	4497H	Retainer Spring 1"	224	193099X428	Console Toolbox
158	194350	Keeper Belt T/A			
159	76020412	Pin Cotter 1/8 x 3/4			

**NOTE:** All component dimensions given in U.S. inches  
1 inch = 25.4 mm

# TRACTOR - - MODEL NUMBER 944.606092

## STEERING ASSEMBLY

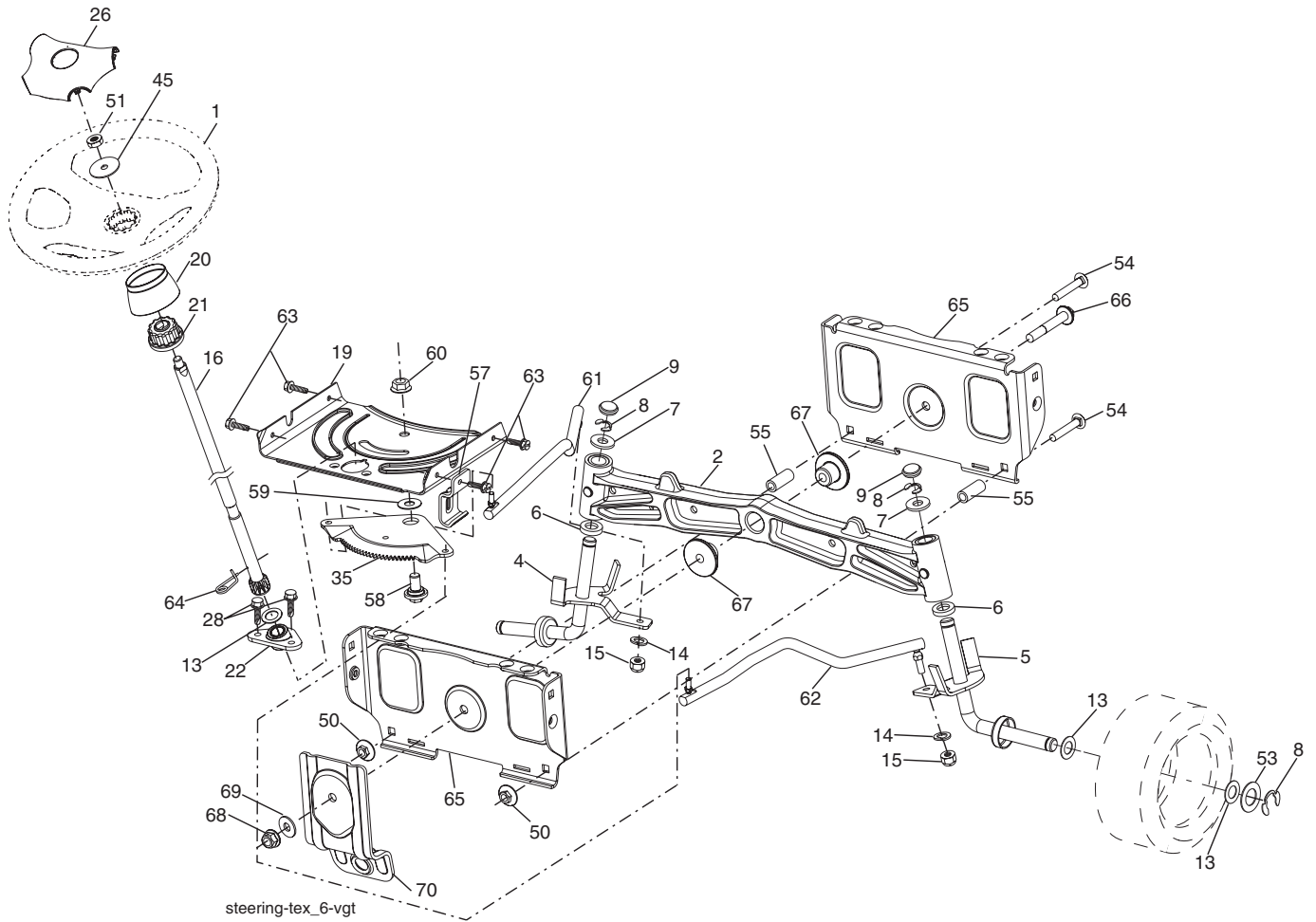

# TRACTOR - - MODEL NUMBER 944.606092

## STEERING ASSEMBLY

KEY NO.	PART NO.	DESCRIPTION
1	186093X428	Wheel, Steering
2	195968	Axle Asm., Front
4	197937	Spindle Asm., LH
5	197936	Spindle Asm., RH
6	6266H	Bearing, Race Thrust Harden
7	121748X	Washer 25/32 x 1-5/8 x 16 Ga.
8	12000029	Ring, Klip #T5304-75
9	184946X505	Cap, Spindle
13	121749X	Washer 25/32 x 1-1/4 x 16 Ga.
14	STD551137	Washer, Lock Hvy Hlcl Spr 3/8
15	73540600	Nut, Crown Lock 3/8-24 unf
16	194746	Shaft Steering
19	194729	Plate Steering
20	199676X428	Boot, Steering
21	186737	Adapter, Wheel Steering
22	194845	Bushing, Strg. Blk
26	186095X428	Insert, Wheel Steering
28	17000612	Screw 3/8-16 x 3/4
35	194732	Gear, Sector Plate
45	19183812	Washer 9/16 x 2-3/8 x 12 Ga.
50	73900600	Nut Lock Flg. 3/8-16 unc
51	73940800	Nut Hex Jam Toplock 1/2-20 unf
53	188967	Washer Hardened .793 x 1.637 x .060
54	74760636	Bolt Hex Hs 3/8-16 unc x 2-1/4
55	197636	Spacer Brace Axle
57	197246	Bracket Upstop
58	194747	Bolt Shoulder Sector Pivot CFM
59	194748	Washer Thrust Sector Steering
60	73971000	Nut Flange Lock 5/8-11
61	194740	Draglink LH
62	194741	Draglink, RH
63	17000512	Screw 5/16-18 x 3/4
64	199849	Retainer Clip Spring Steering
65	194734	Brace Axle Front
66	71020748	Bolt Hex Fghd 7/16-14 x 3 Serr
67	194737	Bushing PM Front Axle
68	73900700	Nut Lock Flange 7/16-14 Gr. 5
69	199162	Washer 1.5 x .505 x .118
70	196197	Bracket Deck Susp. Front

**NOTE:** All component dimensions given in U.S. inches  
1 inch = 25.4 mm

# TRACTOR - - MODEL NUMBER 944.606092

## ENGINE

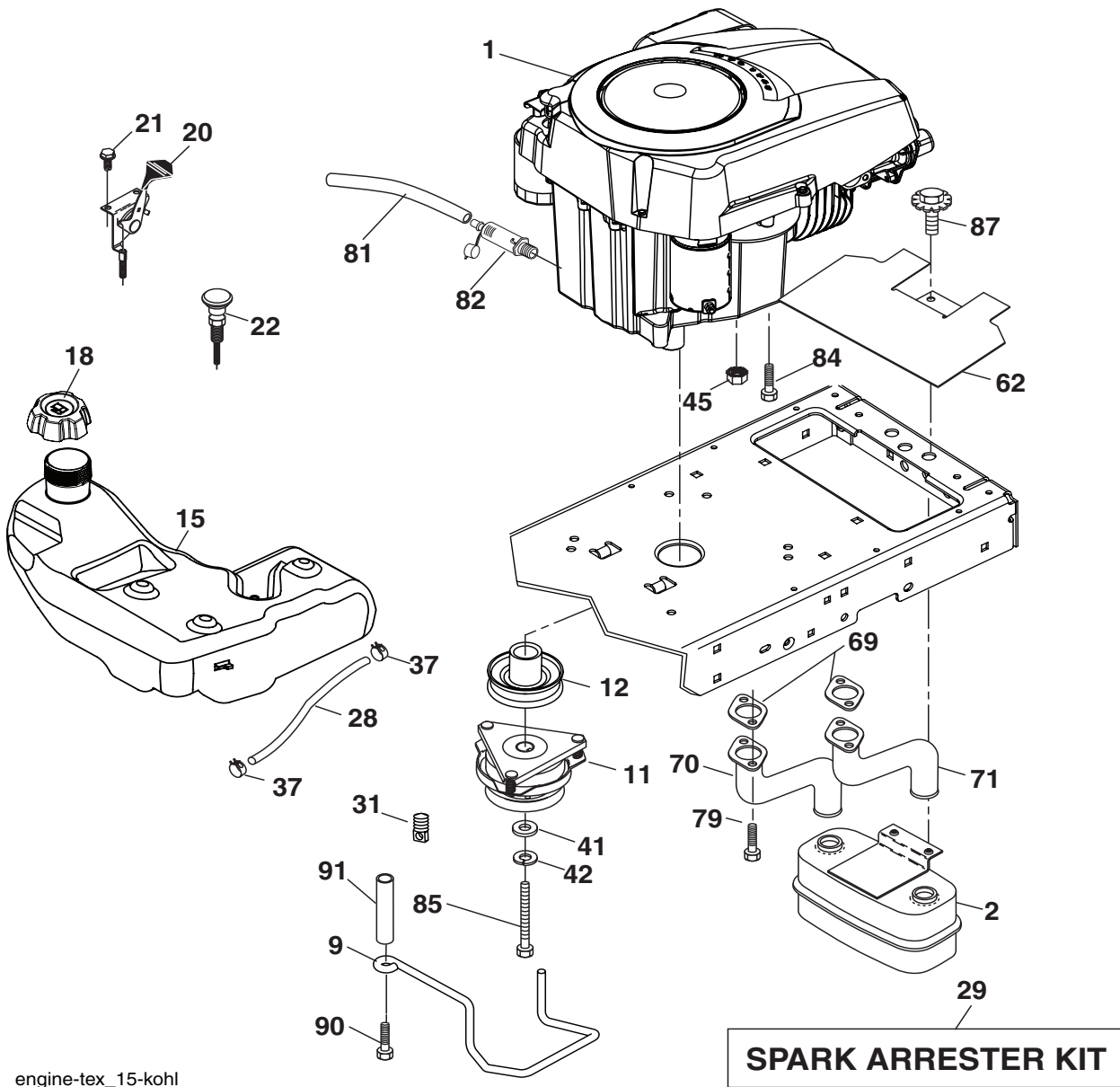

engine-tex\_15-kohl

KEY NO.	PART NO.	DESCRIPTION
1	-----	Engine Kohl Model No. SV740-0020 (See Engine Breakdown)
2	149723	Muffler
9	194320	Keeper Asm. Belt Engine
11	179335	Clutch Electric
12	194343	Pulley Engine
15	193499	Tank Fuel 4.0
18	195951	Cap Asm
20	177328X428	Control Throttle
21	191611	Screw 10 x 3/4 Single Lead-Hex
22	187767X428	Control Choke
28	8543R	Fuel Line
29	137180	Spark Arrester Kit
31	145006	Clip Push-In Hinged
37	123487X	Clamp Hose
41	126197X	Washer 1-1/2 OD x 15/32 ID x .250

KEY NO.	PART NO.	DESCRIPTION
42	STD551143	Washer Lock 7/16
45	73510400	Nut Keps Hex 1/4-20 unc
62	146629	Shield Heat Muffler
69	-----	Gasket (Order parts from mfr.)
70	146699	Tube Exhaust LH
71	146700	Tube Exhaust RH
81	148456	Tube Drain Oil Easy
82	181654	Plug Drain Oil
84	17120616	Screw 3/8-16 x 1
85	179953	Bolt Hex 7/16-20 x 3.75 Gr. 5
87	198239	Bolt 5/16-18 unc x 1 w/Sems
90	17000616	Screw 3/8-16 x 1
95	192334	Screw Socket Hd. 5/16-18 x .75

**NOTE:** All component dimensions given in U.S. inches  
1 inch = 25.4 mm

# TRACTOR - - MODEL NUMBER 944.606092

## SEAT ASSEMBLY

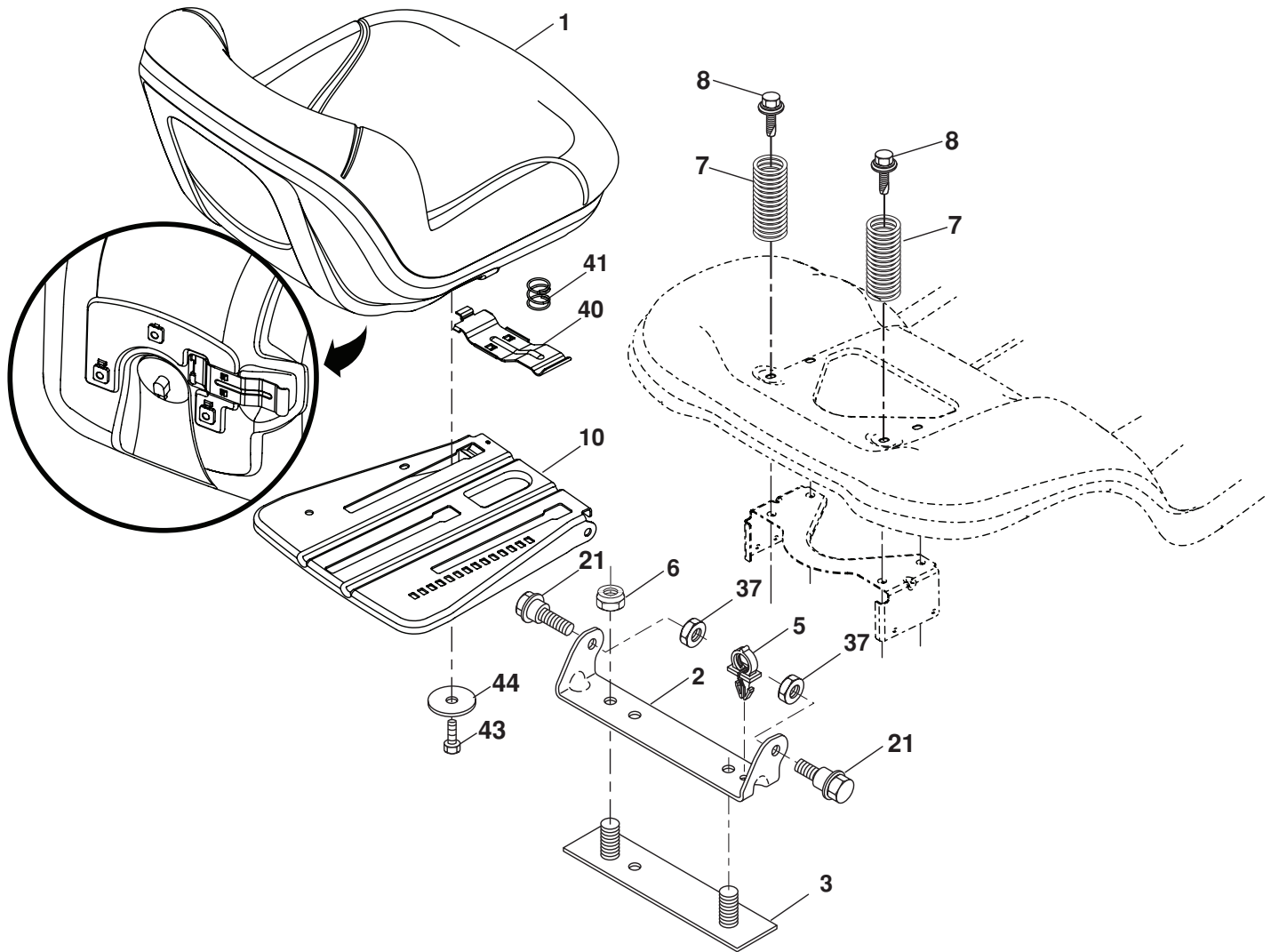

seat-tex\_7-vgt

KEY NO.	PART NO.	DESCRIPTION
1	197528	Seat
2	180166	Bracket Pivot Fender
3	140675	Strap, Asm Fender
5	145006	Clip, Push In, Hinged
6	STD541437	Nut, Lock W/Ins. 3/8-16 unc
7	124181X	Spring, Seat Cprsn
8	171877	Bolt 5/16-18 uncx 3/4 w/Sems
10	196977	Pan, Seat

KEY NO.	PART NO.	DESCRIPTION
21	171852	Bolt, Shoulder 5/16-18
37	STD541431	Nut, Lock 5/16-18 unc
40	197661	Handle Slide Seat
41	198200	Spring Latch Seat
43	74760612	Bolt Fin Hex 3/8-16 unc x 3/4
44	19133812	Washer 13/32 x 2-3/8 x 12 Ga.

**NOTE:** All component dimensions given in U.S. inches  
1 inch = 25.4 mm

# TRACTOR - - MODEL NUMBER 944.606092

## DECALS

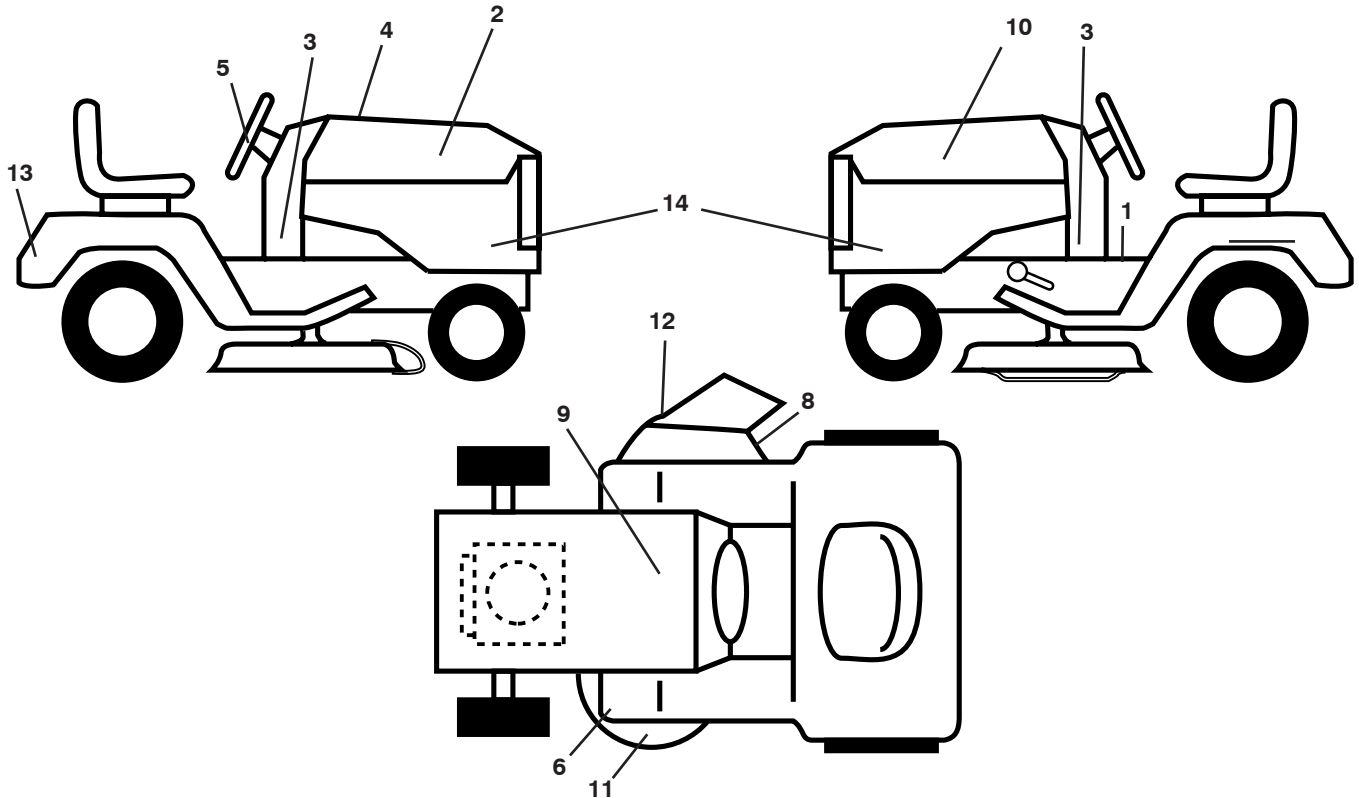

KEY NO.	PART NO.	DESCRIPTION
1	402104	Decal, Operator's
2	403695	Decal, Hood RH
3	405056	Decal, Chassis
4	405040	Decal, Replacement
5	164065	Decal, Strg Whl
6	199135	Decal, V-Belt Sch
8	198785	Decal, Mower Sch.
9	149517	Decal, Battery Dnge/Poi
10	403696	Decal, Hood LH

KEY NO.	PART NO.	DESCRIPTION
11	178502	Decal, Mower Caution
12	170563	Decal, Mower Warning Keep Hand Away
13	403258	Decal, Fender
14	401580	Decal, Panel SD
--	166960	Decal, Bypass
--	193279X428	Pad, Footrest, LH
--	193101X428	Pad, Footrest, RH
--	410187	Manual, Owner's (English)
--	410188	Manual, Owner's (French)

## WHEELS AND TIRES

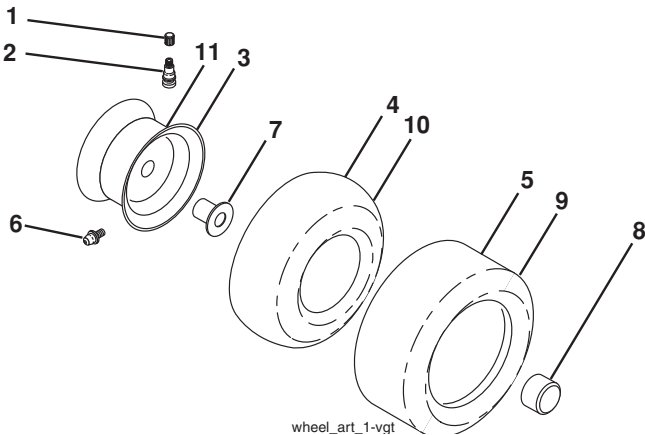

KEY NO.	PART NO.	DESCRIPTION
1	59192	Cap, Valve, Tire
2	65139	Stem, Valve
3	106228X645	Rim Assembly, Front
4	59904	Tube, Front (Service Item Only)
5	106230X	Tire, Front
6	278H	Fitting, Grease (Front Wheel Only)
7	9040H	Bearing, Flange (Front Wheel Only)
8	104757X645	Cap, Axle (Front Wheel Only)
9	105588X	Tire, Rear
10	7152J	Tube, Rear (Service Item Only)
11	106277X645	Rim Assembly, Rear
--	144334	Sealant, Tire (10 oz. Tube)

**NOTE:** All component dimensions given in U.S. inches  
1 inch = 25.4 mm



# TRACTOR - - MODEL NUMBER 944.606092

## MOWER LIFT

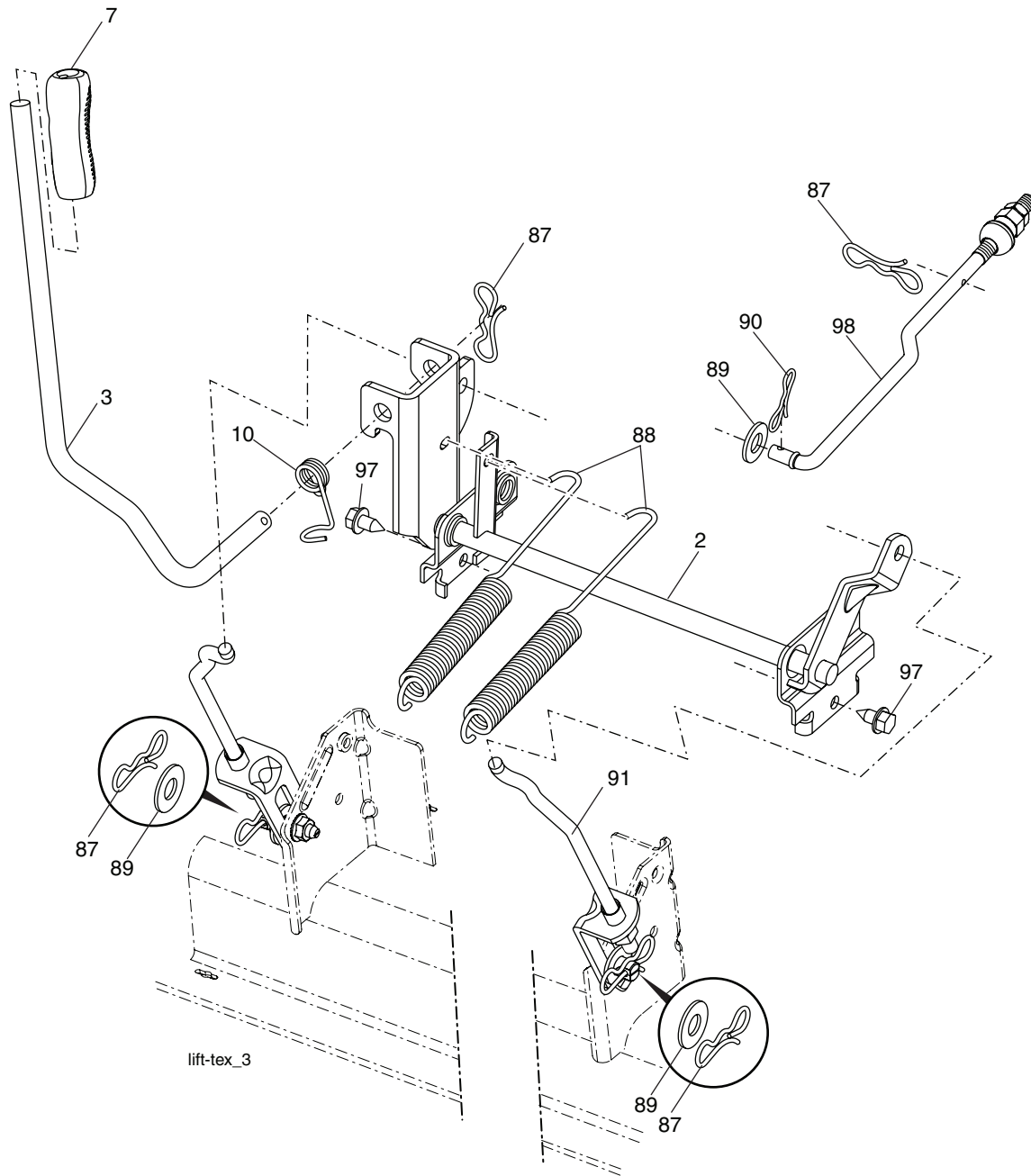

KEY NO.	PART NO.	DESCRIPTION
2	195223	Shaft Asm., Lift
3	195230	Lever Asm., Lift Rh
7	196492	Grip, Lever
10	196314	Spring Torsion
87	194209	Pin Cotter 7/16 Bow Tie Lock
88	195304	Spring Lift Assist
89	19191912	Washer Clear Zinc

KEY NO.	PART NO.	DESCRIPTION
90	194208	Pin Cotter 5/16 Bow Tie Lock
91	403407	Link Lift Susp Mower Rear
97	17060612	Screw 3/8-16 x .75 Smgml Tap/R.Z
98	195264	Link Lift Susp. Front Mower

**NOTE:** All component dimensions given in U.S. inches  
1 inch = 25.4 mm

# TRACTOR - - MODEL NUMBER 944.606092

## MOWER DECK

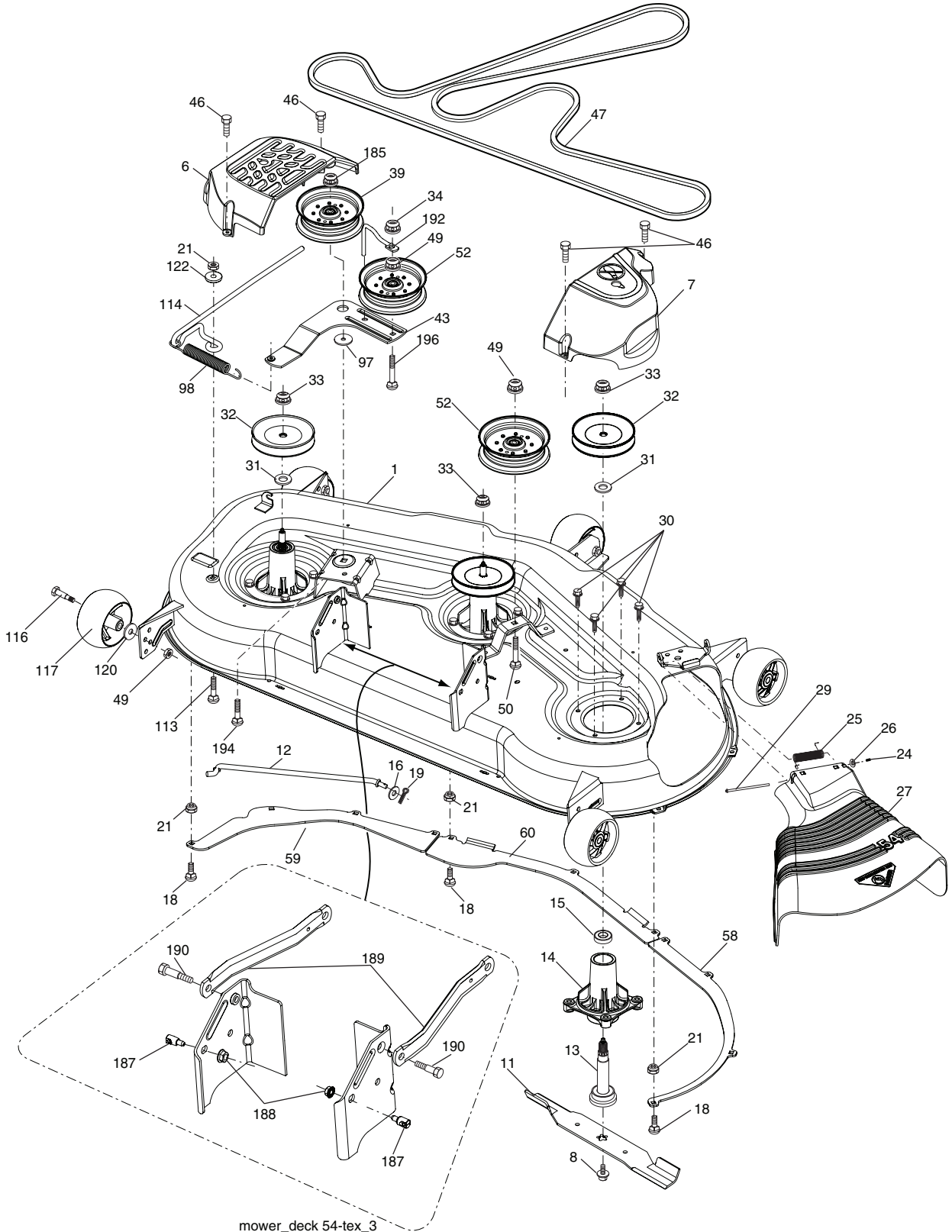

## TRACTOR - - MODEL NUMBER 944.606092

### MOWER DECK

KEY NO.	PART NO.	DESCRIPTION	KEY NO.	PART NO.	DESCRIPTION
1	195632X613	Deck Weldment Mower	50	STD533720	Bolt RDHD SQNK 3/8-16UNC x 2
6	196066	Cover Mandrel LH	52	196106	Pulley Idler Clutching
7	197181	Cover Mandrel RH	58	187342	Baffle Right
8	174365	Bolt 7/16 Asm. Blade	59	187344	Baffle Left
--	187255	Blade Mulching	60	187607	Baffle Center
11	187256	Blade Bagging	97	178515	Washer Hardened
12	400337	Rod Anti-Sway	98	196105	Spring Drive
13	187291	Shaft Asm. w/Lower Bearing	113	72110508	Bolt Rdhd Sqnk 5/16-18 x 3/4
14	187281	Housing, Mandrel	114	187556	Rod Tension Relief
15	110485X	Bearing, Ball, Mandrel	116	193406	Bolt, Shoulder
16	19131312	Washer 13/32 x 13/16 x 12 Ga.	117	174873	Gauge Wheel
18	72140505	Bolt Rdhd Sqnk 5/16-18 x	120	19132012	Washer 13/32 x 1-1/4 x 12Ga.
19	194208	Pin Cotter 5/16 Bow Tie Lock	122	187557	Bushing Tension Relief
21	STD541431	Nut, Crownlock 5/16-18 unc	185	73900700	Nut Lock Flange 7/16-14 Gr. 5
24	105304X	Cap Sleeve	187	195161	Stud Fastener w/"D" Anti-Rotation
25	178102	Spring, Torsion	188	73900500	Nut Lock Hex Flange 5/16-18
26	110452X	Nut, Push	189	195185	Arm Susp. Mower Rear
27	187257X428	Deflector Shield	190	196539	Bolt Shoulder
29	131491	Rod, Hinge	192	198468	Keeper Belt Idler
30	173984	Screw, Thdroll Washer Head	194	72140716	Bolt Carr Sqnk 3/8-16 x 2-1/4
31	187690	Washer, Spacer Mower Vented	196	72140620	Bolt Rdhd Sqnk 3/8-16 x 2-1/2 Gr. 5
32	173436	Pulley, Mandrel	--	187254	High Lift Blade
33	400234	Nut, Flg. Top Lock	--	187292	Mandrel Asm. Service (Includes Key Nos. 13-15 and 33)
34	STD541437	Nut Crownlock 3/8-16UNC	--	403349	Replacement Mower, Complete
39	196104	Pulley, Idler, Stationary			
43	196065	Arm, Idler			
46	137729	Screw, Thdroll. 1/4-20 x 5/8			
47	196103	V-Belt, Mower			
49	73900600	Nut, Lock Flg. 3/8-16 unc			

**NOTE:** All component dimensions given in U.S. inches  
1 inch = 25.4 mm

# REPAIR PARTS

## TRACTOR - - MODEL NUMBER 944.606092

### HYDRO TRANSAXLE - - MODEL NUMBER 347-3000

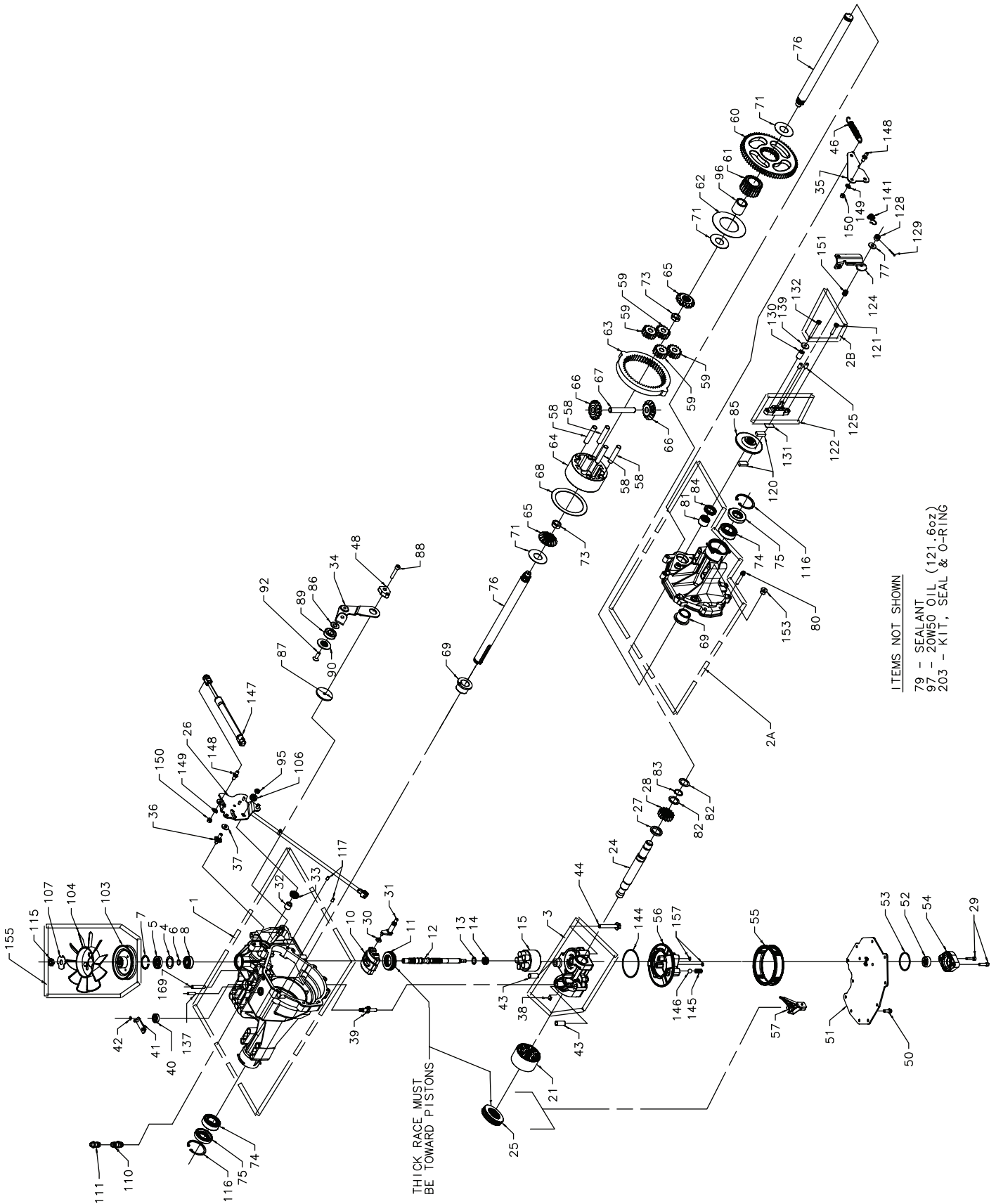

# REPAIR PARTS

## TRACTOR - - MODEL NUMBER 944.606092

### HYDRO TRANSAXLE - - MODEL NUMBER 347-3000

KEY NO.	PART NO.	DESCRIPTION	KEY NO.	PART NO.	DESCRIPTION
1	161122	Kit, Housing Main Main Housing Lip Seal	74	169535	Bearing, Ball (310-3000)
		Flange Bearing	75	161157	Seal, Lip (310-3000)
		Trunnion Bushing Cradle Bearing	76	161158	Shaft, Axle (310-3000)
2a	193015	Kit, Housing R/H R.H. Housing Flange	77	142884	Washer, Flat
		Bearing	79	178322	Sealant Tube
		Needle Bearing (Sce1412) Lip Seal (.875 ID X 1.3 OD X.25)	80	161159	Screw, Torx Head 5/16-18 (310-3000)
2b	193016	Kit, Brake Bolt	81	161160	Bearing, Needle (210-3000)
		Bolt, Hex HD 1/4-20 X 1.25 W/patch Bolt,	82	161161	Washer, Flat (0.880 Id) (310-3000)
		Hex Hd 1/4-20 X 2.25 W/patch	83	161162	Ring, Retaining (310-3000)
3	404259	Kit, Center Section Center Section Bushing.50 X.60 X.50	84	161163	Seal, Lip (.875 ID X 1.38 OD X.25) (310-3000)
		Bushing.90 X 1.02 X.75 Plate, Bypass	85	161164	Brake Disc (310-3000)
		Check Plug Assembly,.044 Check Plug	86	170418	Washer, .5 X 1.0 X.032
		Assembly,.027	87	178323	Spacer, .32 X 1.96 X.15
4	161125	Spacer (BDP, Bdu 10)	88	178784	Screw, Socket HD Cap 5/16-24 X 1.5
5	142932	Seal, Lip	89	178783	Bearing, Ball.62 X 1.38 X.44
6	142928	Retaining Ring	90	178786	Spacer, Locating
7	142933	Retaining Ring	92	178787	Screw, Countersunk 5/16-18 X 1.0
8	142934	Bearing, Ball	95	169537	Nut, Nylon Insert Hex Lock 5/16-24
10	169524	Swash Plate (BDP, BDU 10)	96	169538	Bearing, Sleeve (310-3000)
11	173159	Bearing, Thrust (10cc)	97	20w-50	Oil 122 Oz
12	161126	Shaft, Input (310-3000)	103	170440	Pulley 3.68
13	142978	Washer, Block Thrust	104	170439	Fan 7.0, 10 Blade
14	142977	Spring, Helical Compression	106	161166	Spacer, Trunnion (310-3000)
15	169898	Kit, Cylinder Block (1000) 10cc	107	199658	Washer, Od Slotted.53 X 1.63 X.06
		Cylinder Block 10cc Piston 10cc Piston	110	150813	O-ring Fitting, Plastic Hose O-ring
		Spring Piston Seat Washer	111	150812	Breather Vent, Plastic Vent, Plastic Vent, Cap
21	150786	Block, (Bd-21& lht) 21 CC Cylinder Block	115	150794	Hex Nut 1/2-20
		Piston	116	169539	Ring, Retaining (310-3000)
		Seat Washer 21 CC Piston 21cc Piston Spring	117	161168	Pin
24	161127	Shaft, Motor (310-3000)	120	142883	Brake Puck
25	169526	Bearing, Thrust (21cc)	121	193019	Bolt, Hex HD 1/4-20 X 1.25 W/patch
26	404260	Assembly, GT RCS	122	178329	Kit, Brake Yoke
27	161129	Spacer (310-3000)	124	178330	Brake Arm
28	161130	Gear, 16T Pinion	125	170409	Pin, Brake Actuating
29	169527	Capscrew	128	170415	Nut, Castle 5/16-24
30	142941	Guide Block (Bd-21)	129	170416	Pin, Cotter 3/32x3/4
31	169887	Trunnion, Tapered Square	130	170411	Spacer, Brake Torsion Spring
32	161133	Bearing, Journal	131	142882	Brake Puck Plate
33	142940	Seal, Lip	132	193020	Bolt, Hex HD 1/4-20 X 2.25 W/patch
34	404261	Arm, Return	139	161176	Washer, Flat
35	404262	Bracket, Damper	141	178335	Spring, Brake Arm Bias
36	169871	Stud DB End 5/16-24 X 1.5	144	169545	O-ring
37	142967	Friction Puck	145	169546	Spring, Relief
38	184694	Kit, Bypass Plate	146	169547	Steel Ball 7/16
39	169529	Bypass Actuator (IHT)	147	404264	Damper
40	142945	Seal, Lip	148	178802	Stud, Threaded Ball
41	142952	Bypass Arm	149	178808	Washer, 5/15 Lock
42	142953	Retaining Ring	150	178804	Nut, Hex 5/16-18
43	142965	Pin	151	170417	Brake Spring
44	150797	Bolt 3/8-24 X 2-1/2	152	178336	Brake Pull Rod
46	404263	Spring, 4 In Extension	153	170434	Plug, Straight Thread 9/16-18
48	178792	Puck, Adjusting	155	178337	Kit, Fan/pulley Nut, Jam 1/2-20
50	178343	Screw, Hex Head Washer Cap Screw (IZT) 1/4-20 X	157	169548	Washer, Od Slotted.53 X 1.63 X.06
51	169530	Lower Cover	169	184701	Pulley Fan
52	169531	Geroter Assembly	203	178338	O-ring
53	144581	O-ring			Pin, Spring 5/16 X 1.75
54	161139	Charge Pump Housing			Kit, Seal
55	178321	Kit, Filter			Lip Seal 15 X 5 X 37
		Gasket.10 X .16 X 4.24			Lip Seal 12 X 25 X 7
		Filter			Lip Seal 10 X 25 X 7
56	169533	Charge Manifold 310-3000			O-ring.103 X 1.862
57	161142	Retainer, Motor Bearing (310-3000)			Seal 25 X 52 X 10
58	161143	Pin, Carrier (310-3000)			Lip Seal.875 ID X 1.3 OD X.25
59	161144	Gear, 15T Planet (310-3000)			O-ring.070 X.239
60	161145	Gear, 67T Spur (310-3000)			Kit, O-ring, Manifold
61	161146	Gear, 21T Sun (310-3000)	900	199651	Pin, Spring 5/16 X 1.75
62	161147	Plate, Planet Thrust (310-3000)			Pin, Spring 1/4 X 1.00
63	161148	Gear, 51T Ring (310-3000)			Transaxle
64	161149	Carrier, Planetary (310-3000)			
65	161150	Gear, Differential Bevel (310-3000)			
66	161151	Gear, Differential Bevel Pinion (310-3000)			
67	161152	Shaft, Differential (310-3000)			
68	161153	Plate, Differential Thrust (310-3000)			
69	169534	Bearing, Flange (310-3000)			
71	161155	Washer, Flat (1.00 Id) (310-3000)			
73	161156	Nut, 5/8-18 Hex Jam (310-3000)			

**NOTE:** All Component Dimensions Given In U.S. Inches 1 Inch = 25.4 mm

# REPAIR PARTS

TRACTOR - - MODEL NUMBER 944.606092  
KOHLER ENGINE - MODEL NUMBER SV740, TYPE NUMBER 0020

## CYLINDER HEAD, VALVE AND BREATHER

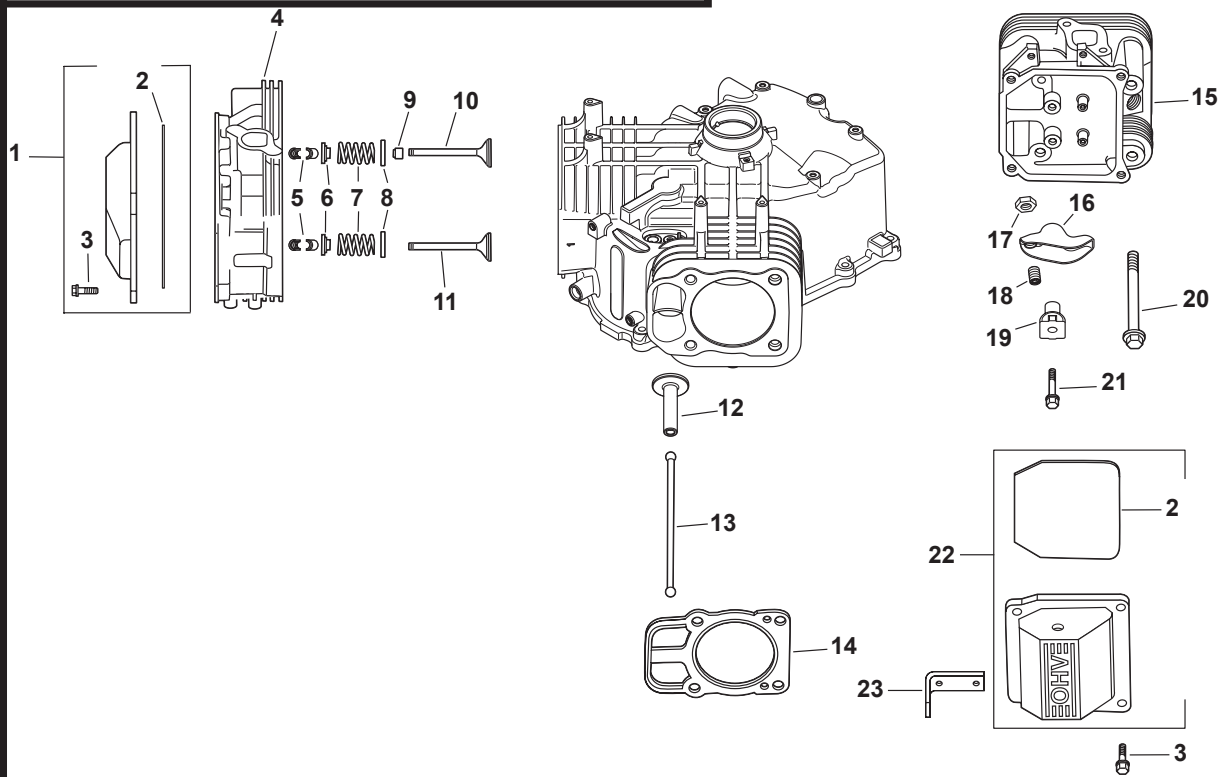

## CRANKCASE

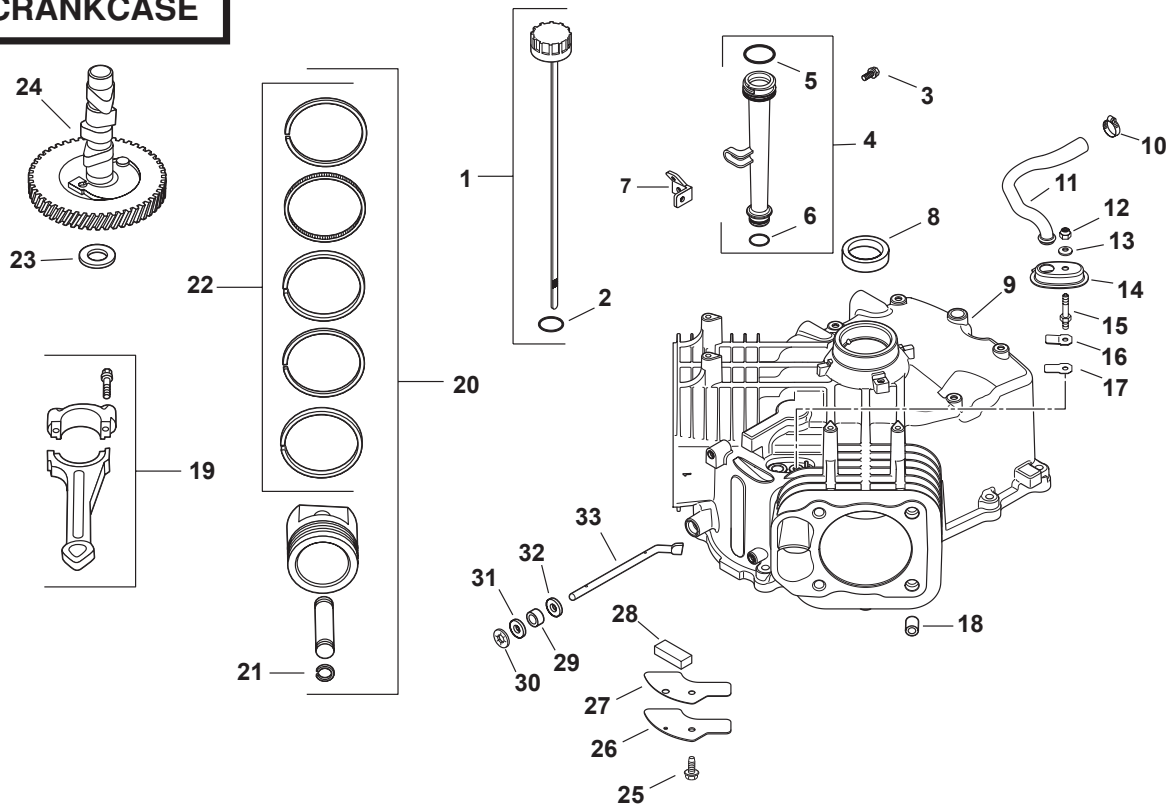

# REPAIR PARTS

## TRACTOR - - MODEL NUMBER 944.606092

### KOHLER ENGINE - MODEL NUMBER SV740, TYPE NUMBER 0020

#### HEAD/VALVE/BREATHER

KEY NO.	PART NO.	DESCRIPTION
1	24 755 141-S 1	Kit, valve cover - plain (Includes 2,3 [qty. 4])
2	24 153 28-S 1	O-Ring
3	M-651030-S 8	Screw, flg M6x1.0x30
4	32 318 01-S 1	Head assembly, #1 cylinder (Includes 20 & head gasket)
5	12 755 03-S 4	Kit, retainer
6	12 173 01-S 4	Cap, valve spring
7	24 089 02-S 4	Spring, valve
8	235011-S 4	Retainer, spring
9	66 032 05-S 2	Seal, valve stem
10	24 017 01-S 2	Valve, intake (Std.)
	24 017 02-S 2	Valve, intake (.25)
11	24 016 01-S 2	Valve, exhaust (Std.)
	24 016 02-S 2	Valve, exhaust (.25)
12	32 019 01-S 4	Tappet
13	32 411 02-S 4	Rod, push
14	24 841 03-S 2	Kit, cylinder head gasket (Includes head mounting hardware & 24 041 49-S, 24 153 27-S)
15	32 318 02-S 1	Head assembly, #2 cylinder (Includes 20 & head gasket)
16	32 186 02-S 4	Arm, rocker
17	32 100 04-S 4	Nut, M10x0.75
18	32 086 03-S 4	Screw, set
19	24 599 01-S 4	Pivot, rocker arm
20	12 086 16-S 8	Screw, flg M10x1.5x90
21	32 086 04-S 4	Screw, flg M6x1.0x45
22	32 096 06-S 1	Kit, valve cover - breather (Includes 2)
23	24 445 01-S 1	Strap, lifting
<b>NOT ILLUSTRATED</b>		
	24 041 49-S 1	Gasket, exhaust manifold
	24 153 27-S 1	O-Ring, intake port

#### CRANKCASE

KEY NO.	PART NO.	DESCRIPTION
1	24 038 04-S 1	Kit, dipstick (Includes 2)
2	25 153 02-S 1	O-Ring
3	M-545013-S 1	Screw, flg thd frm M5x0.8x13
4	12 123 04-S 1	Tube, oil fill (Includes 5,6)
5	12 153 02-S 1	O-Ring, upper oil fill tube
6	12 153 01-S 1	O-Ring, lower oil fill tube
7	24 126 19-S 1	Bracket, oil fill tube
8	24 032 01-S 1	Seal, oil
9	----- 1	Crankcase (USE: Short Block)
10	25 237 14-S 1	Clamp, hose
11	32 326 04-S 1	Hose, breather
12	M-547050-S 1	Nut, lock M5x0.8
13	32 468 01-S 1	Washer, sealing
14	32 081 02-S 1	Housing, breather
15	32 072 02-S 1	Stud, breather cover
16	24 018 04-S 1	Retainer, breather reed
17	12 402 02-S 1	Reed, breather
18	24 380 16-S 6	Pin, locating
19	24 067 20-S 2	Connecting Rod (Std.)
20	32 874 06-S 2	Piston w/Ring Set (Std.) (Includes 21,22)
21	24 018 01-S 4	Retainer, piston pin
22	24 108 11-S 2	Ring Set (Std.)
23	12 422 10-S	A.R. Shim, camshaft (yellow .034")
	12 422 09-S	A.R. Shim, camshaft red .032")
	12 422 13-S	A.R. Shim, camshaft (black .04")
	12 422 07-S	A.R. Shim, camshaft (white .028")
	12 422 08-S	A.R. Shim, camshaft (blue .03")
	12 422 11-S	A.R. Shim, camshaft (green .036")
	12 422 12-S	A.R. Shim, camshaft (gray .038")
24	32 012 01-S 1	Kit, camshaft (Includes 25 357 14-S)
25	M-645016-S 1	Screw, flg thd frm M6x1.0x16
26	32 096 04-S 1	Cover, breather
27	32 041 01-S 1	Gasket, breather cover
28	32 050 01-S 1	Filter, breather
29	28 032 09-S 1	Seal, governor cross shaft
30	24 018 09-S 1	Ring, retainer
31	M-931010-S 1	Washer, flat 9 mm
32	24 468 15-S 1	Washer, flat 11/32"
33	24 144 38-S 1	Shaft, governor cross
<b>NOT ILLUSTRATED</b>		
	25 357 14-S 1	Lubricant, camshaft

**NOTE:** All component dimensions given in U.S. inches  
1 inch = 25.4 mm

# REPAIR PARTS

TRACTOR - - MODEL NUMBER 944.606092  
KOHLER ENGINE - MODEL NUMBER SV740, TYPE NUMBER 0020

## IGNITION/ELECTRICAL

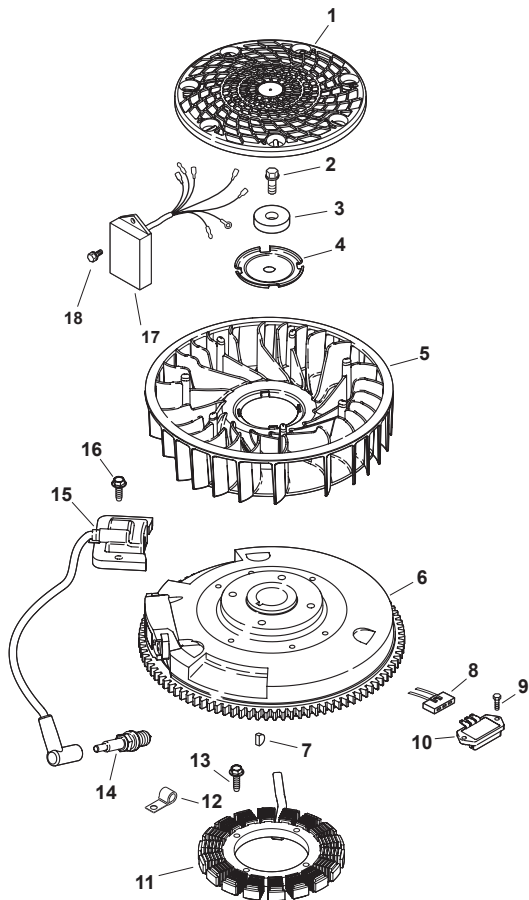

## BLOWER HOUSING AND BAFFLES

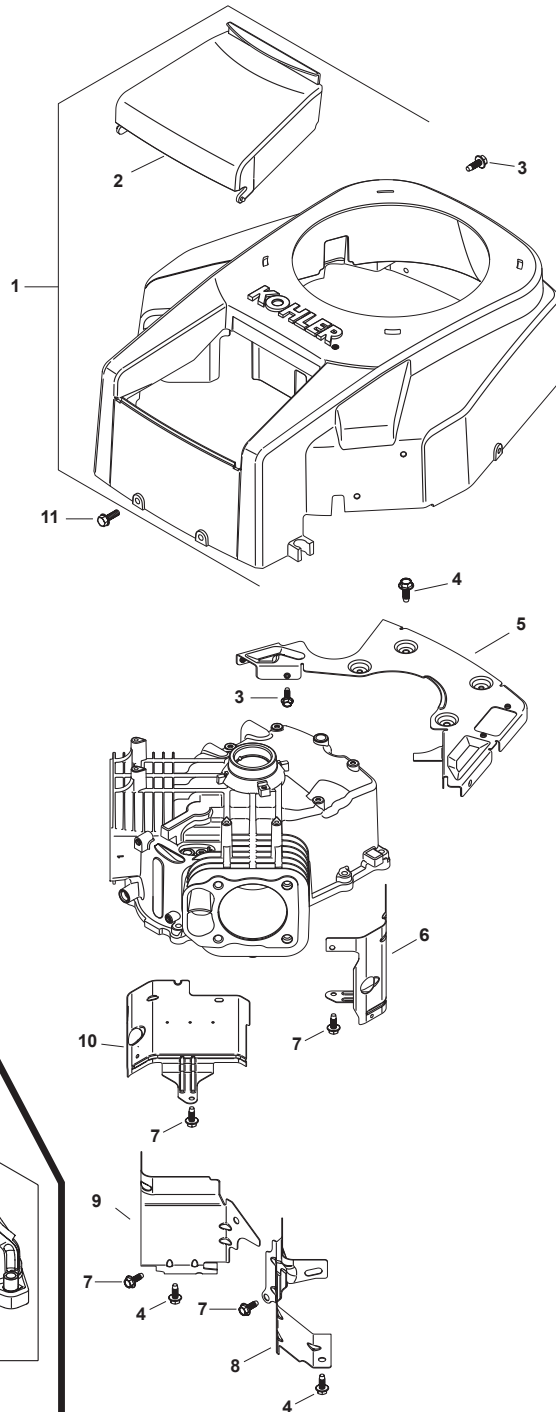

## AIR INTAKE

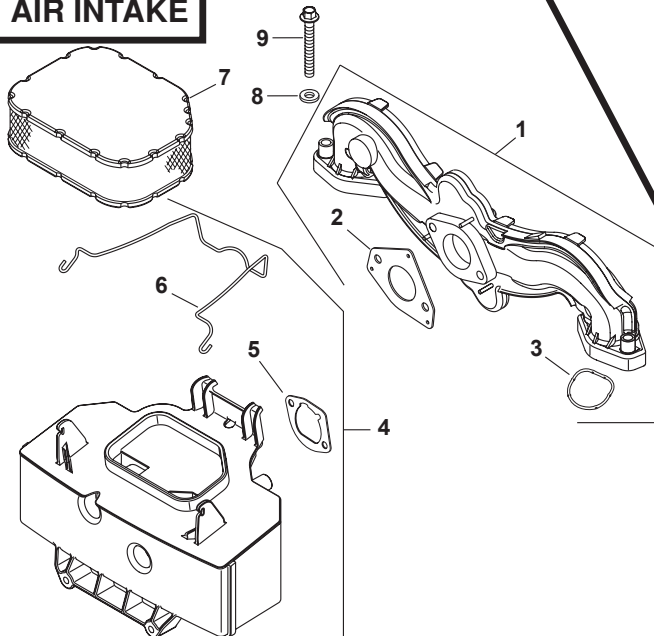



# REPAIR PARTS

## TRACTOR - - MODEL NUMBER 944.606092

### KOHLER ENGINE - MODEL NUMBER SV740, TYPE NUMBER 0020

#### IGNITION/ELECTRICAL

KEY NO.	PART NO.		DESCRIPTION
1	32 162 03-S	1	Screen, grass
2	12 086 14-S	1	Screw, flg M10x1.5x45
3	12 468 03-S	1	Washer, flat 3/8"
4	20 146 02-S	1	Plate, fan mounting
5	32 157 01-S	1	Fan
6	32 025 05-S	1	Flywheel
7	X-42-15-S	1	Key
8	236602-S	1	Connector (3 contact)
9	M-551016-S	2	Screw, hvy flg M5x0.8x16
10	41 403 09-S	1	Rectifier-regulator
11	237878-S	1	Kit, 15 amp stator
12	47 154 01-S	1	Clip, cable
13	M-548025-S	2	Screw, thd frm M5x0.8x25
14	25 132 12-S	2	Spark plug
15	24 584 36-S	2	Module, ignition
16	M-545020-S	4	Screw, flg thd frm M5x0.8x20
17	24 584 31-S	1	Module, speed advance
18	M-448010-S	2	Screw, thd frm M4x0.7x10
<b>NOT ILLUSTRATED</b>			
	32 176 03-S	1	Harness, wiring
	25 454 03-S	2	Tie, wire

#### BLOWER HOUSING & BAFFLES

1	32 027 03-S	1	Housing, blower (Includes 2, 41 037 10-S)
2	32 096 08-S	1	Cover, air cleaner
3	M-545016-S	6	Screw, flg thd frm M5x0.8x16
4	M-645016-S	6	Screw, flg thd frm M6x1.0x16
5	32 146 05-S	1	Plate, backing w/rectifier-regulator opening
6	32 063 05-S	1	Baffle, cylinder barrel - #2 side
7	M-545010-S	5	Screw, flg thd frm M5x0.8x10
8	32 063 02-S	1	Baffle, valley - #2 side
9	32 063 03-S	1	Baffle, valley - #1 side
10	32 063 04-S	1	Baffle, cylinder barrel - #1 side
11	24 086 12-S	2	Screw, tap M6x1.7x18
<b>NOT ILLUSTRATED</b>			
	41 037 10-S	1	Nameplate, service

#### AIR INTAKE/FILTRATION

1	24 164 51-S	1	Manifold, intake (Includes 2,3)
2	24 041 52-S	1	Gasket, carburetor
3	24 153 27-S	2	O-Ring, intake port
4	32 094 04-S	1	Base, air cleaner (Includes 5,6)
5	24 041 14-S	1	Gasket, air cleaner base
6	32 344 02-S	1	Latch, air cleaner element
7	32 083 03-S	1	Element, air cleaner
8	X-25-63-S	1	Washer, flat 1/4"
9	M-651040-S	4	Screw, flg M6x1.0x40

**NOTE:** All component dimensions given in U.S. inches  
1 inch = 25.4 mm

# REPAIR PARTS

TRACTOR - - MODEL NUMBER 944.606092  
KOHLER ENGINE - MODEL NUMBER SV740, TYPE NUMBER 0020

## STARTING SYSTEM

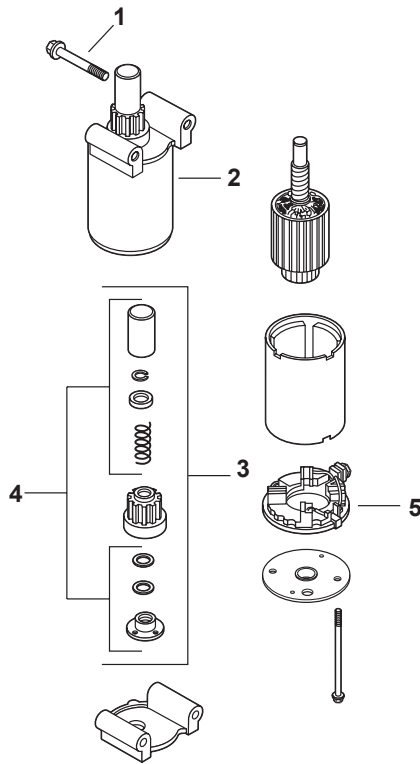

## OIL PAN/LUBRICATION

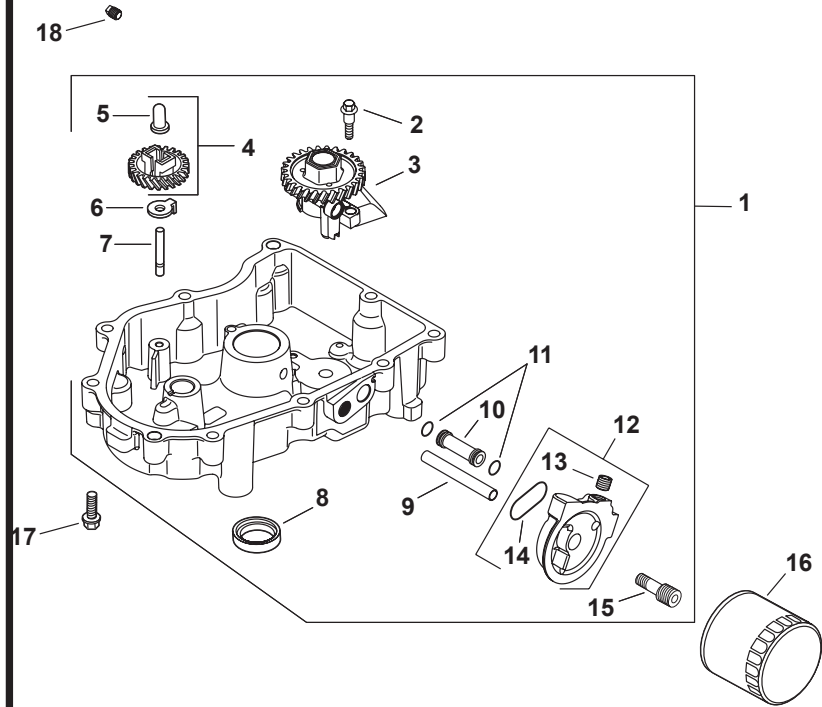

## ENGINE CONTROLS

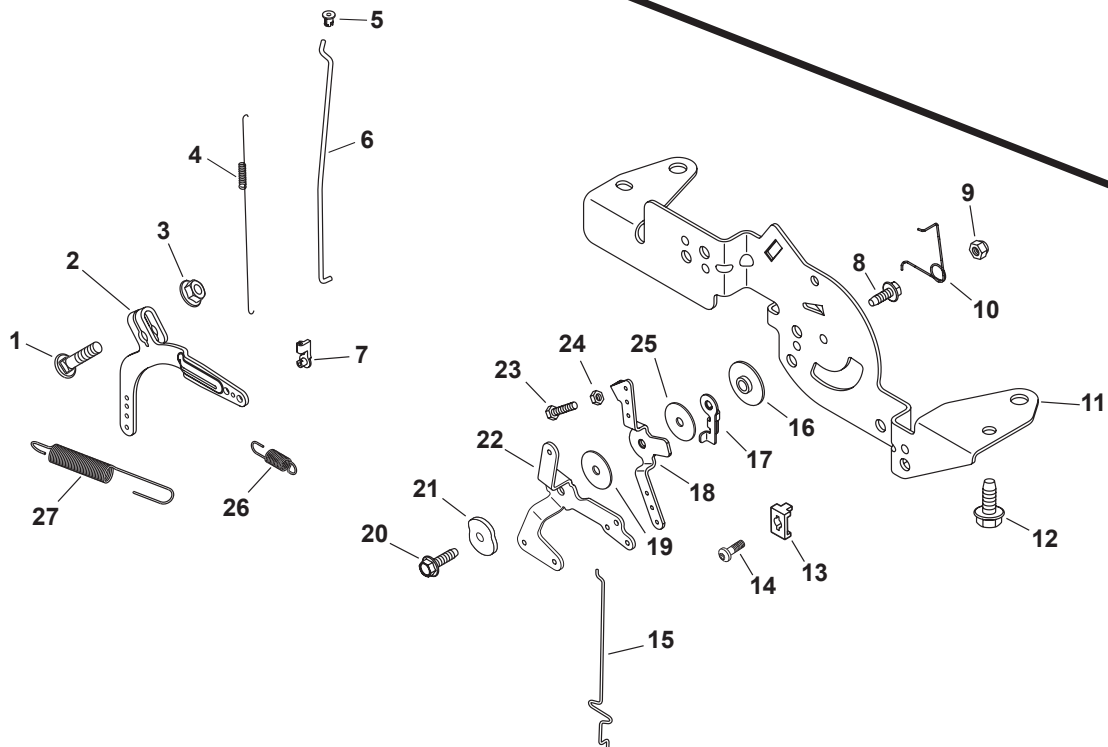

# REPAIR PARTS

## TRACTOR - - MODEL NUMBER 944.606092 KOHLER ENGINE - MODEL NUMBER SV740, TYPE NUMBER 0020

### STARTING SYSTEM

KEY NO.	PART NO.	DESCRIPTION
1	M-839080-S	2 Screw, flg M8x1.25x70
2	32 098 01-S	1 Starter assembly (Includes 3-5)
3	12 755 39-S	1 Kit, drive
4	12 755 38-S	1 Kit, drive parts
5	12 243 04-S	1 Commutator, end cap

### OIL PAN/LUBRICATION

KEY NO.	PART NO.	DESCRIPTION
1	32 199 02-S	1 Pan assembly, oil (Includes 2-15)
2	32 086 01-S	2 Screw, flg thd frm shd M6x1.0x13
3	32 393 10-S	1 Pump assembly, oil
4	24 043 12-S	1 Kit, governor gear w/pin (Includes 5)
5	12 380 01-S	1 Pin, governor regulating
6	24 448 02-S	1 Tab, locking
7	12 144 02-S	1 Shaft, governor gear
8	52 032 08-S	1 Seal, oil (PTO end)
9	32 123 01-S	1 Tube, oil feed - filter to oil pan
10	32 123 03-S	1 Tube, oil feed - oil pan to filter
11	24 153 01-S	2 O-Ring
12	32 029 07-S	1 Adapter, oil filter (Includes 13,14)
13	25 139 60-S	1 Plug, ctsk 1/8"
14	32 153 04-S	1 O-Ring, oil filter adapter
15	32 136 03-S	1 Nipple, oil filter
16	52 050 02-S	1 Filter, oil
17	24 086 17-S	10 Screw, flg M8x1.25x45
18	25 139 57-S	1 Plug, sq hd solid 3/8"

### ENGINE CONTROLS

KEY NO.	PART NO.	DESCRIPTION
1	24 211 03-S	1 Bolt, rd hd sqe neck M6x1.0x25
2	24 090 33-S	1 Lever, governor
3	M-641060-S	1 Nut, flg M6x1.0
4	24 089 01-S	1 Spring, linkage
5	25 158 08-S	1 Bushing, linkage retaining
6	24 079 04-S	1 Linkage, throttle
7	25 158 11-S	1 Bushing, throttle linkage
8	M-545016-S	1 Screw, flg thd frm M5x0.8x16
9	M-547050-S	1 Nut, lock M5x0.8
10	24 089 03-S	1 Spring, choke return
11	24 126 161-S	1 Bracket, control
12	M-645016-S	4 Screw, flg thd frm M6x1.0x16
13	12 237 01-S	2 Clamp, cable
14	24 086 43-S	2 Screw, lbd thd frm M5x0.8x16
15	24 079 22-S	1 Linkage, choke
16	24 112 27-S	1 Spacer, control assembly
17	24 090 47-S	1 Lever, throttle actuator
18	24 090 13-S	1 Lever, throttle control
19	24 468 01-S	1 Washer, flat 5.5 mm
20	M-545020-S	1 Screw, flg thd frm M5x0.8x20
21	41 468 03-S	1 Washer, spring 1/4"
22	24 090 05-S	1 Lever, choke
23	M-403025-S	1 Screw, slt hd cap M4x0.7x25
24	M-446030-S	1 Nut, M4x0.7
25	24 468 20-S	1 Washer, flat 5 mm
26	24 089 55-S	1 Spring, governor
27	24 089 25-S	1 Spring, governor

**NOTE:** All component dimensions given in U.S. inches  
1 inch = 25.4 mm

# REPAIR PARTS

TRACTOR - - MODEL NUMBER 944.606092

KOHLER ENGINE - MODEL NUMBER SV740, TYPE NUMBER 0020

## CRANKSHAFT

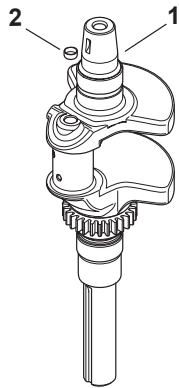

## EXHAUST

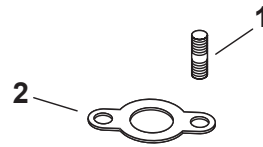

## FUEL SYSTEM

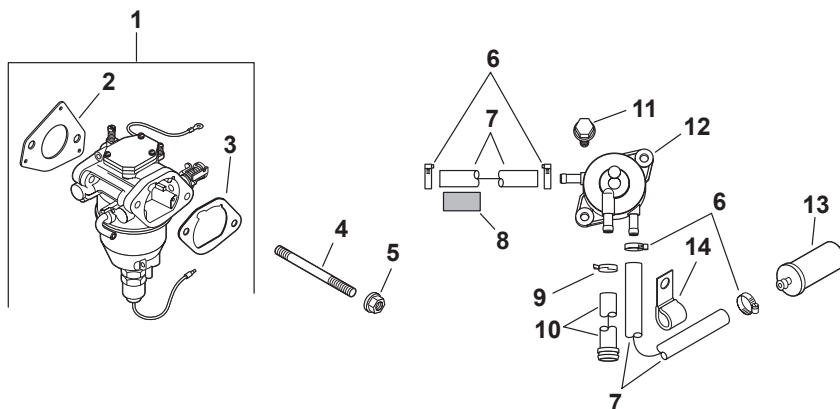

# REPAIR PARTS

## TRACTOR - - MODEL NUMBER 944.606092 KOHLER ENGINE - MODEL NUMBER SV740, TYPE NUMBER 0020

### CRANKSHAFT

KEY NO.	PART NO.	DESCRIPTION
1	32 014 02-S	1 Crankshaft (Includes 2)
2	52 139 09-S	1 Plug, cup

### EXHAUST

KEY NO.	PART NO.	DESCRIPTION
1	25 072 04-S	4 Stud, M8x1.25x33
2	24 041 49-S	2 Gasket, exhaust manifold
1	25 113 39-S	1 Decal, clear laminate

### NOT ILLUSTRATED

32 522 02	1	Short Block
32 755 01-S	1	Kit, overhaul

### FUEL SYSTEM

KEY NO.	PART NO.	DESCRIPTION
1	32 853 04-S	1 Kit, carburetor w/gaskets (Includes 2,3)
2	24 041 52-S	1 Gasket, carburetor
3	24 041 14-S	1 Gasket, air cleaner base
4	M-629105-S	2 Stud, M6x1.0x106
5	M-641060-S	2 Nut, flg M6x1.0
6	25 237 14-S	4 Clamp, hose
7	25 111 34-S	2 Line, fuel (24" - Cut to length)
8	25 431 10-S	1 Sleeve, anti-abrasion
9	25 237 01-S	1 Clamp, hose
10	32 326 02-S	1 Hose, fuel pump
11	24 086 12-S	2 Screw, tap M6x1.7x18
12	24 393 16-S	1 Pump, pulse fuel
13	24 050 10-S	1 Filter, fuel
14	47 154 01-S	1 Clip, cable

### NOT ILLUSTRATED

#### For Service of Keihin Carburetors

24 757 36-S	1	Kit, service choke repair (Includes 2,3)
24 757 38-S	1	Kit, service gasket repair (Includes 2,3)
24 757 44-S	1	Kit, float (Includes 2,3)
24 757 45-S	1	Kit, solenoid valve (Includes 2,3)
24 757 46-S	1	Kit, overhaul (Includes 2,3)

#### For Service of Nikki Carburetors

24 757 18-S	1	Kit, overhaul (Includes 2,3 & Float Kit)
24 757 19-S	1	Kit, service choke repair (Includes 2,3)
24 757 20-S	1	Kit, service gasket repair (Includes 2,3)
24 757 22-S	1	Kit, solenoid valve (Includes 2,3)

**NOTE:** All component dimensions given in U.S. inches  
1 inch = 25.4 mm

---

# SERVICE NOTES

---

# SUGGESTED GUIDE FOR SIGHTING SLOPES FOR SAFE OPERATION

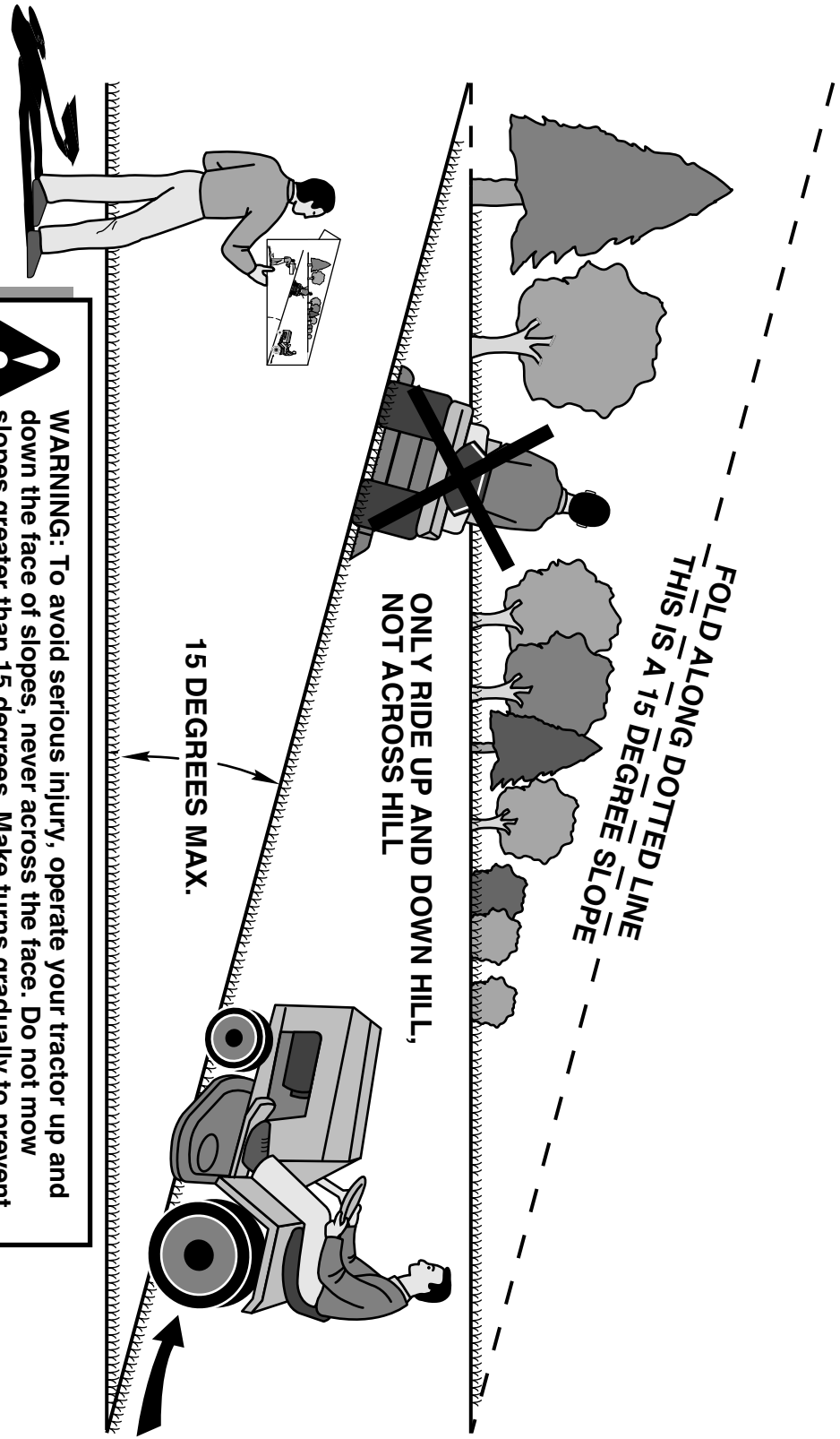

 **WARNING:** To avoid serious injury, operate your tractor up and down the face of slopes, never across the face. Do not mow slopes greater than 15 degrees. Make turns gradually to prevent tipping or loss of control. Exercise extreme caution when changing direction on slopes.

1. Fold this page along dotted line indicated above.
2. Hold page before you so that its left edge is vertically parallel to a tree trunk or other upright structure.
3. Sight across the fold in the direction of hill slope you want to measure.
4. Compare the angle of the fold with the slope of the hill.

# Get it fixed, at your home or ours!

Just Call:

**1-800-4-MY-HOME<sup>®</sup>**

(1-800-469-4663)

24 hours a day, 7 days a week

For the repair of major brand appliances **in your own home...**  
no matter who made it, no matter who sold it!

For your nearest **Sears Parts and Service** location,  
to bring in products like vacuums, lawn equipment and electronics.

For **Sears Parts & Service**, to order the replacement parts,  
accessories and owner's manuals that you need to do-it-yourself.

[www.sears.ca](http://www.sears.ca)

---

To purchase or inquire about a Sears Maintenance Agreement, call:

**1-800-361-6665**

9 a.m. – 11 p.m. Mon. – Fri., EST, 9 a.m. – 4 p.m. Sat.

---

Pour service en français:

**1-800-LE-FOYER<sup>MC</sup>**

(1-800-533-6937)

[www.sears.ca](http://www.sears.ca)



02488

® / TM Trademarks of Sears, Roebuck and Co. used under license by Sears Canada

MD Marque déposée / MC Marque de commerce de Sears, Roebuck and Co. utilisée en vertu d'une licence de Sears Canada