

**SEARS**

# CRAFTSMAN®

**MODEL NUMBER 917.256410 OWNER'S MANUAL**

- **Assembly**
- **Operation**
- **Customer Responsibilities**
- **Service and Adjustments**
- **Repair Parts**

same as 944.606130

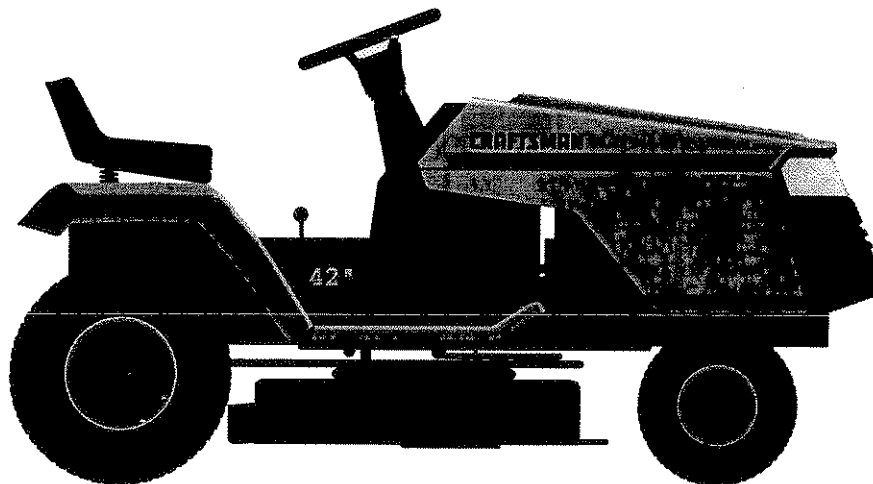

 This product has a low emission engine which is not compatible with previously built engines. Before you start the engine, read and understand this Owner's Manual.

**CAUTION: Read and follow all safety rules and instructions before operating this equipment.**  
FOR CONSUMER ASSISTANCE HOT LINE, CALL THIS TOLL FREE NUMBER: 1-800-659-5917

Sears, Roebuck and Co., Hoffman Estates, IL 60179 U.S.A.



# SAFETY RULES



## Safe Operation Practices for Ride-On Mowers

**IMPORTANT:** THIS CUTTING MACHINE IS CAPABLE OF AMPUTATING HANDS AND FEET AND THROWING OBJECTS. FAILURE TO OBSERVE THE FOLLOWING SAFETY INSTRUCTIONS COULD RESULT IN SERIOUS INJURY OR DEATH.

### I. GENERAL OPERATION

- Read, understand, and follow all instructions in the manual and on the machine before starting.
- Only allow responsible adults, who are familiar with the instructions, to operate the machine.
- Clear the area of objects such as rocks, toys, wire, etc., which could be picked up and thrown by the blade.
- Be sure the area is clear of other people before mowing. Stop machine if anyone enters the area.
- Never carry passengers.
- Do not mow in reverse unless absolutely necessary. Always look down and behind before and while backing.
- Be aware of the mower discharge direction and do not point it at anyone. Do not operate the mower without either the entire grass catcher or the guard in place.
- Slow down before turning.
- Never leave a running machine unattended. Always turn off blades, set parking brake, stop engine, and remove keys before dismounting.
- Turn off blades when not mowing.
- Stop engine before removing grass catcher or unclogging chute.
- Mow only in daylight or good artificial light.
- Do not operate the machine while under the influence of alcohol or drugs.
- Watch for traffic when operating near or crossing roadways.
- Use extra care when loading or unloading the machine into a trailer or truck.

### II. SLOPE OPERATION

Slopes are a major factor related to loss-of-control and tipover accidents, which can result in severe injury or death. All slopes require extra caution. If you cannot back up the slope or if you feel uneasy on it, do not mow it.

#### DO:

- Mow up and down slopes, not across.
- Remove obstacles such as rocks, tree limbs, etc.
- Watch for holes, ruts, or bumps. Uneven terrain could overturn the machine. *Tall grass can hide obstacles.*
- Use slow speed. Choose a low gear so that you will not have to stop or shift while on the slope.
- Follow the manufacturer's recommendations for wheel weights or counterweights to improve stability.
- Use extra care with grass catchers or other attachments. *These can change the stability of the machine.*
- Keep all movement on the slopes *slow and gradual*. Do not make sudden changes in speed or direction.
- Avoid starting or stopping on a slope. If tires lose traction, disengage the blades and proceed slowly *straight* down the slope.

#### DO NOT:

- *Do not* turn on slopes unless necessary, and then, turn slowly and gradually downhill, if possible.
- *Do not* mow near drop-offs, ditches, or embankments. The mower could suddenly turn over if a wheel is over the edge of a cliff or ditch, or if an edge caves in.
- *Do not* mow on wet grass. Reduced traction could cause sliding.
- *Do not* try to stabilize the machine by putting your foot on the ground.
- *Do not* use grass catcher on steep slopes.

### III. CHILDREN

Tragic accidents can occur if the operator is not alert to the presence of children. Children are often attracted to the machine and the mowing activity. *Never* assume that children will remain where you last saw them.

- Keep children out of the mowing area and under the watchful care of another responsible adult.
- Be alert and turn machine off if children enter the area.
- Before and when backing, look behind and *down* for small children.
- Never carry children. They may fall off and be seriously injured or interfere with safe machine operation.
- Never allow children to operate the machine.
- Use extra care when approaching blind corners, shrubs, trees, or other objects that may obscure vision.

### IV. SERVICE

- Use extra care in handling gasoline and other fuels. They are flammable and vapors are explosive.
  - Use only an approved container.
  - Never remove gas cap or add fuel with the engine running. Allow engine to cool before refueling. Do not smoke.
  - Never refuel the machine indoors.
  - Never store the machine or fuel container inside where there is an open flame, such as a water heater.
- Never run a machine inside a closed area.
- Keep nuts and bolts, especially blade attachment bolts, tight and keep equipment in good condition.
- Never tamper with safety devices. Check their proper operation regularly.
- Keep machine free of grass, leaves, or other debris build-up. Clean oil or fuel spillage. Allow machine to cool before storing.
- Stop and inspect the equipment if you strike an object. Repair, if necessary, before restarting.
- Never make adjustments or repairs with the engine running.
- Grass catcher components are subject to wear, damage, and deterioration, which could expose moving parts or allow objects to be thrown. Frequently check components and replace with manufacturer's recommended parts, when necessary.
- Mower blades are sharp and can cut. Wrap the blade(s) or wear gloves, and use extra caution when servicing them.
- Check brake operation frequently. Adjust and service as required.



**Look for this symbol to point out important safety precautions. It means CAUTION!!! BECOME ALERT!!! YOUR SAFETY IS INVOLVED.**



**CAUTION: Always disconnect spark plug wire and place wire where it cannot contact spark plug in order to prevent accidental starting when setting up, transporting, adjusting or making repairs.**



**WARNING**  
The engine exhaust from this product contains chemicals known to the State of California to cause cancer, birth defects, or other reproductive harm.

**CONGRATULATIONS** on your purchase of a Sears Tractor. It has been designed, engineered and manufactured to give you the best possible dependability and performance.

Should you experience any problem you cannot easily remedy, please contact your nearest Sears Authorized Service Center/Department. We have competent, well-trained technicians and the proper tools to service or repair this tractor.

Please read and retain this manual. The instructions will enable you to assemble and maintain your tractor properly. Always observe the "SAFETY RULES".

MODEL NUMBER	917.256410
SERIAL NUMBER	_____
DATE OF PURCHASE	_____
THE MODEL AND SERIAL NUMBERS WILL BE FOUND ON A PLATE UNDER THE SEAT.	
YOU SHOULD RECORD BOTH SERIAL NUMBER AND DATE OF PURCHASE AND KEEP IN A SAFE PLACE FOR FUTURE REFERENCE.	

## PRODUCT SPECIFICATIONS

HORSEPOWER:	13.5
GASOLINE CAPACITY AND TYPE:	5 QUARTS UNLEADED REGULAR
OIL TYPE (API-SF/SG):	SAE 30 (above 32°F) SAE 5W-30 (below 32°F)
OIL CAPACITY:	3 PINTS
SPARK PLUG: (GAP: .030")	CHAMPION RJ19LM STD361458
VALVE CLEARANCE:	INTAKE: .005" - .007" EXHAUST: .009" - .011"
GROUND SPEED (MPH):	FORWARD: 1st 1.0 2nd 1.3 3rd 2.1 4th 3.1 5th 4.0 6th 5.1 REVERSE: 1.6
TIRE PRESSURE:	FRONT: 14 PSI REAR: 12 PSI
CHARGING SYSTEM:	3 AMPS BATTERY 5 AMPS HEADLIGHTS
BATTERY:	AMP/HR: 25 MIN. CCA: 190 CASE SIZE: U1R
BLADE BOLT TORQUE:	30-35 FT. LBS.

## MAINTENANCE AGREEMENT

A Sears Maintenance Agreement is available on this product. Contact your nearest Sears store for details.

## CUSTOMER RESPONSIBILITIES

- Read and observe the safety rules.
- Follow a regular schedule in maintaining, caring for and using your tractor.
- Follow the instructions under "Customer Responsibilities" and "Storage" sections of this owner's manual.

**WARNING:** This tractor is equipped with an internal combustion engine and should not be used on or near any unimproved forest-covered, brush-covered or grass-covered land unless the engine's exhaust system is equipped

with a spark arrester meeting applicable local or state laws (if any). If a spark arrester is used, it should be maintained in effective working order by the operator.

In the state of California the above is required by law (Section 4442 of the California Public Resources Code). Other states may have similar laws. Federal laws apply on federal lands. A spark arrester for the muffler is available through your nearest Sears Authorized Service Center/Department (See REPAIR PARTS section of this manual).

## LIMITED TWO YEAR WARRANTY ON CRAFTSMAN RIDING EQUIPMENT

For two (2) years from the date of purchase, if this Craftsman Riding Equipment is maintained, lubricated and tuned up according to the instructions in the owner's manual, Sears will repair or replace, free of charge, any parts found to be defective in material or workmanship.

This Warranty does not cover:

- Expendable items which become worn during normal use, such as blades, spark plugs, air cleaners, belts, etc.
- Tire replacement or repair caused by punctures from outside objects, such as nails, thorns, stumps, or glass.
- Repairs necessary because of operator abuse, negligence, improper storage or accident or the failure to maintain the equipment according to the instructions contained in the owner's manual.
- Riding equipment used for commercial or rental purposes.

## LIMITED 90 DAY WARRANTY ON BATTERY

For ninety (90) days from date of purchase, if any battery included with this riding equipment proves defective in material or workmanship and our testing determines the battery will not hold a charge, Sears will replace the battery at no charge.

IN-HOME WARRANTY SERVICE ON YOUR CRAFTSMAN RIDING EQUIPMENT IS AVAILABLE AT NO-CHARGE FOR 30 DAYS FROM THE DATE OF PURCHASE. PLEASE CONTACT YOUR NEAREST SERVICE CENTER. AFTER 30 DAYS FROM THE DATE OF PURCHASE, WARRANTY SERVICE IS AVAILABLE BY TAKING YOUR CRAFTSMAN RIDING EQUIPMENT TO YOUR NEAREST SEARS SERVICE CENTER. (IN-HOME WARRANTY SERVICE WILL STILL BE AVAILABLE AFTER 30 DAYS FROM THE DATE OF PURCHASE BUT A STANDARD TRIP CHARGE WILL APPLY.) THIS WARRANTY APPLIES ONLY WHILE THIS PRODUCT IS IN THE TRACTORED STATES.

This Warranty gives you specific legal rights, and you may also have other rights which may vary from state to state.

SEARS, ROEBUCK AND CO., D/817 WA, HOFFMAN ESTATES, IL 60179

# TABLE OF CONTENTS

SAFETY RULES ..... 2  
 PRODUCT SPECIFICATIONS ..... 3  
 CUSTOMER RESPONSIBILITIES ..... 3, 15-18  
 WARRANTY ..... 3  
 TRACTOR ACCESSORIES ..... 5  
 ASSEMBLY ..... 7-9  
 OPERATION ..... 10-14

MAINTENANCE SCHEDULE ..... 15  
 SERVICE AND ADJUSTMENTS ..... 19-24  
 STORAGE ..... 25  
 TROUBLESHOOTING ..... 26-27  
 REPAIR PARTS - TRACTOR ..... 30-47  
 REPAIR PARTS - ENGINE ..... 48-52  
 PARTS ORDERING/SERVICE ..... BACK COVER





## INDEX

<p><b>A</b></p> <p>Accessories ..... 5</p> <p>Adjustments:</p> <p>  Brake ..... 21</p> <p>  Carburetor ..... 24</p> <p>  Mower</p> <p>    Front-To-Back ..... 20</p> <p>    Side-To-Side ..... 20</p> <p>    Throttle Control Cable ..... 24</p> <p>Air Filter, Engine ..... 17-18</p> <p>Air Screen, Engine ..... 18</p> <p>Assembly ..... 7-9</p> <p><b>B</b></p> <p>Battery:</p> <p>  Charging ..... 8</p> <p>  Cleaning ..... 17</p> <p>  Starting with Weak Battery ..... 22</p> <p>  Storage ..... 25</p> <p>  Terminals ..... 17</p> <p>Belt:</p> <p>  Motion Drive</p> <p>    Removal/Replacement ..... 21</p> <p>  Mower Belt(s)</p> <p>    Removal/Replacement ..... 21</p> <p>Blade:</p> <p>  Sharpening ..... 16</p> <p>  Replacement ..... 16</p> <p>Brake Adjustment ..... 21</p> <p><b>C</b></p> <p>Carburetor Adjustment ..... 24</p> <p>Controls, Tractor ..... 11</p> <p>Customer Responsibilities ..... 15-18</p> <p>  Engine:</p> <p>    Air Filter ..... 17</p> <p>    Air Screen ..... 18</p> <p>    Cooling Fins ..... 18</p> <p>    Engine Oil ..... 13,17</p> <p>    Fuel Filter ..... 18</p> <p>    Spark Plug(s) ..... 18</p> <p>  Tractor:</p> <p>    Battery ..... 16-17</p> <p>    Blade ..... 16</p> <p>    Lubrication Chart ..... 15</p> <p>    Maintenance Schedule ..... 15</p> <p>    Tire Care ..... 8,16,22</p> <p>    Transaxle ..... 17</p> <p>Cutting Height, Mower ..... 12</p> <p><b>E</b></p> <p>Electrical:</p> <p>  Interlocks and Relays ..... 23</p>	<p>Schematic ..... 29</p> <p>Wiring Diagram ..... 30</p> <p>Engine:</p> <p>  Air Filter ..... 17-18</p> <p>  Air Screen ..... 18</p> <p>  Cooling Fins ..... 18</p> <p>  Oil Change ..... 17</p> <p>  Oil Level ..... 13</p> <p>  Oil Type ..... 13,17</p> <p>  Preparation ..... 13</p> <p>  Repair Parts ..... 48-52</p> <p>  Starting ..... 14</p> <p>  Storage ..... 25</p> <p><b>F</b></p> <p>Filter:</p> <p>  Air Filter ..... 17</p> <p>  Fuel ..... 18</p> <p>Fuel:</p> <p>  Type ..... 14</p> <p>  Storage ..... 25</p> <p>Fuse ..... 23</p> <p><b>H</b></p> <p>Hood Removal/Installation ..... 23</p> <p><b>L</b></p> <p>Leveling Mower Deck ..... 20</p> <p>Lubrication:</p> <p>  Chart ..... 15</p> <p>  Engine ..... 17</p> <p><b>M</b></p> <p>Maintenance Schedule ..... 15</p> <p>Mower:</p> <p>  Adjustment, Front-to-Back ..... 20</p> <p>  Adjustment, Side-to-Side ..... 20</p> <p>  Blade Replacement ..... 16</p> <p>  Blade Sharpening ..... 16</p> <p>  Cutting Height ..... 12</p> <p>  Installation ..... 19</p> <p>  Operation ..... 13</p> <p>  Removal ..... 19</p> <p>Mowing Tips ..... 14</p> <p>Muffler ..... 18</p> <p>  Spark Arrester ..... 3,40</p> <p><b>O</b></p> <p>Oil:</p>	<p>Cold Weather Conditions ..... 13,17</p> <p>  Engine ..... 17</p> <p>  Storage ..... 25</p> <p>Operation ..... 10-14</p> <p>Operating Mower ..... 13</p> <p>Options:</p> <p>  Accessories ..... 5</p> <p>  Spark Arrester ..... 3,40</p> <p><b>P</b></p> <p>Parking Brake ..... 11,12</p> <p>Parts Bag ..... 6</p> <p>Parts, Replacement/Repair ..... 30-47</p> <p>Product Specifications ..... 3</p> <p><b>R</b></p> <p>Repair Parts ..... 30-47</p> <p><b>S</b></p> <p>Safety Rules ..... 2</p> <p>Seat ..... 8</p> <p>Service and Adjustments ..... 19-24</p> <p>  Carburetor ..... 24</p> <p>  Fuse ..... 23</p> <p>  Hood Removal/Installation ..... 23</p> <p>  Motion Drive Belt</p> <p>    Removal/Replacement ..... 21</p> <p>  Mower Belt(s)</p> <p>    Removal/Replacement ..... 21</p> <p>  Mower Adjustment</p> <p>    Front-to-Back ..... 20</p> <p>    Side-to-Side ..... 20</p> <p>  Mower Removal/Installation ..... 19</p> <p>  Tire Care ..... 8,16,22</p> <p>Slope Guide Sheet ..... 55</p> <p>Spark Plug(s) ..... 18</p> <p>Specifications ..... 3</p> <p>Starting the Engine ..... 13-14</p> <p>Steering Wheel ..... 7,22</p> <p>Stopping the Tractor ..... 12</p> <p>Storage ..... 25</p> <p><b>T</b></p> <p>Throttle Control Cable Adjustment ..... 24</p> <p>Tires ..... 8,16,22</p> <p>Trouble Shooting Chart ..... 26-27</p> <p>Transaxle ..... 17</p> <p><b>W</b></p> <p>Warranty ..... 3</p> <p>Wiring Diagram ..... 30</p> <p>Wiring Schematic ..... 29</p>
---	---	--

# ACCESSORIES AND ATTACHMENTS

These accessories and attachments were available through most Sears retail outlets and service centers when the tractor was purchased. Most Sears stores can order these items for you when you provide the model number of your tractor.

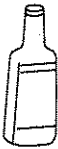
## ENGINE

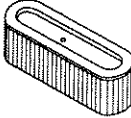
SPARK PLUG	GAS CAN	ENGINE OIL	FUEL STABILIZER	AIR FILTER
				

## MAINTENANCE

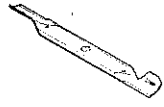
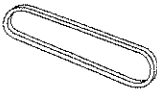
BLADES	BELTS
	

## PERFORMANCE

Sears offers a wide variety of attachments that fit your tractor. Many of these are listed below with brief explanations of how they can help you. This list was current at the time of publication; however, it may change in future years - more attachments may be added, changes may be made in these attachments, or some may no longer be available or fit your model. **Contact your nearest Sears store for the accessories and attachments that are available for your tractor.**

Most of these attachments do not require additional hitches or conversion kits (those that do are indicated) and are designed for easy attaching and detaching.

**AERATOR** promotes deep root growth for a healthy lawn. Tapered 2.5-inch steel spikes mounted on 10-inch diameter discs puncture holes in soil at close intervals to let moisture soak in. Steel weight tray for increased penetration.

**BAGGER** lets you collect grass clippings and leaves for a healthier, neater looking lawn. Two Permanex containers hold 30-gallon plastic bags.

**BUMPER** protects front end of tractor from damage.

**CARTS** make hauling easy. Variety of sizes available, plus accessories such as side panel kits, tool caddy, cart cover, protective mat and dolly.

**CORING AERATOR** takes small plugs out of soil to allow moisture and nutrients to reach grass roots. 36-inch swath. 24 hardened steel coring tips. 150 lb. capacity weight tray.

**EASY OIL DRAIN VALVE** makes oil changes easier, faster.

**FRONT NOSE ROLLER** canters in front of mower deck to reduce chances of "scalping" on uneven terrain.

**GANG HITCH** lets you tow 2 or 3 pull-behind attachments at once, such as sweepers, dethatchers, aerators (not for use with rollers, carts or other heavy attachments).

**GAUGE WHEELS** on both sides of the mower deck reduce chances of "scalping" on uneven terrain. For mower decks not so equipped.

**MULCH RAKE/DETHATCHER** loosens soil and flips thatch and matted leaves to lawn surface for easy pickup. Twenty spring tine teeth. Useful to prepare bare areas for seeding. Available for front or rear mounting. **HIGH PERFORMANCE REEL-ACTION SPRING TINE DETHATCHER** covers 36-inch wide path and tosses thatch into large hopper. Mounts behind tractor.

**MULCHING CLOSE-OUT PLATE KIT**, once installed, lets you mulch, discharge or bag clippings (bagger optional) without changing blades. For models not equipped as 3-in-1 Convertible mowers. See "MOWER" in the Repair Parts section of this manual.

**RAMP TOPS AND FEET** let you load and unload tractor from a pickup truck. Use with 2 x 8 or 2 x 10 lumber.

**ROLLER** for smoother lawn surface. 36-inch wide, 18-inch diameter water-tight drum holds up to 390 lbs. of weight. Rounded edges prevent harm to turf. Adjustable scraper automatically cleans drum.

**SNOW BLADE** for snow removal only. 14-inch high, 48-inch wide blade clears 42-inch path when angled left or right. Raises, lowers with side lever. Adjustable skids; replaceable, reversible scraper bar. (Use with tire chains and wheel weights and/or rear drawbar weight.)

**SNOWTHROWER** has 40-inch swath. Drum-type auger handles powdery and wet/heavy snow. Mounts easily with simple pin arrangement. Discharge chute adjusts from tractor seat. 6-inch diameter spout discharges snow 10 to 50 feet. Lift controlled at tractor seat. (Use with chains and wheel weights and/or rear drawbar weight.)

**SPRAYERS** use 12-volt DC electric motor that connects to the tractor battery or other 12-volt source. Includes booms for automatic spraying and hand held wand for spot spraying. Wand has adjustable spray pattern. For applying herbicides, insecticides, fungicides and liquid fertilizers.

**SPREADER/SEEDERS** make seeding, fertilizing, and weed killing easy. Broadcast spreaders are also useful for granular decifiers and sand.

**SWEEPERS** let you collect grass clippings and leaves.

**TILLER** has 5 hp engine and 36-inch swath to prepare seed beds, cultivate and compost garden residue. Tiller has its own built-in lift and depth control system and does NOT require a sleeve hitch. Fits any lawn, yard or garden tractor. Simply hook up to the tractor drawbar and go! **Optional accessories** convert unit for dethatching, aerating, hilling...without tools.

**TIRE CHAINS** are heavy duty; closely spaced extra-large cross links give smooth ride, outstanding traction.

**TRACTOR CAB** has heavy duty vinyl fabric over tubular steel frame, ABS plastic top; clear plastic windshield offers 360 degree visibility. Hinged metal doors with catch. Keeps operator warm and dry. Remove vinyl sides and windshields for use as sun protector in summer. **Optional accessories include:** tinted/tempered solid safety glass windshield with hand operated wiper; 12-volt amber caution light for mounting on cab top.

**VACS** for powerful collection of heavy grass clippings and leaves. **Optional wand attachment** to pick up debris in hard-to-reach places. **VAC/CHIPPER** includes a chipper-shredder.

**WEIGHT BRACKET** for drawbar for snow removal applications. Uses (1) 55 lb. weight.

**WHEEL WEIGHTS** for rear wheels provide needed traction for snow removal or dozing heavy materials.

# CONTENTS OF HARDWARE PACK

## Parts Bag contents shown full size

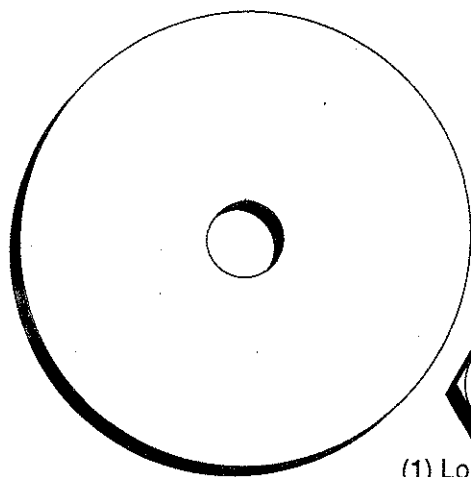

(1) Large Flat Washer

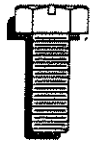

(2) Sheet Metal Screws #10-16 x 1/2



(1) Locknut 3/8-24

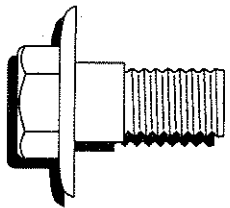

(1) Shoulder Bolt 5/16-18

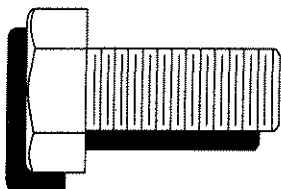

(1) Hex Bolt 1/2-13 x 1

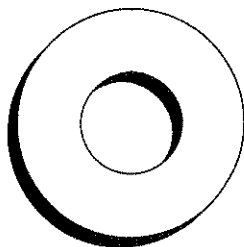

(1) Washer 17/32 x 1-3/16 x 12 Gauge

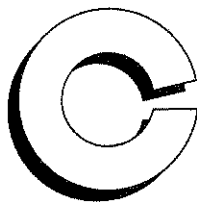

(1) Lock Washer 1/2



(2) Hex Bolts 1/4-20 x 3/4



(2) Hex Nuts 1/4-20



(2) Washers 9/32 x 5/8 x 16 Gauge



(2) Lock Washers 1/4

## Parts packed separately in carton

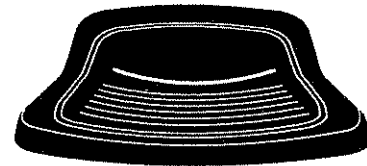

Seat

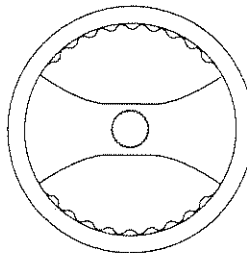

Steering Wheel

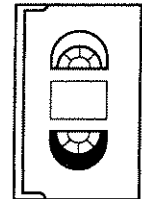

Video Cassette



Steering Boot



Manual

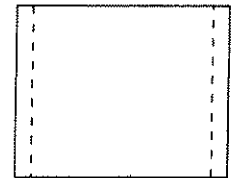

Parts Bag

## Parts bag contents not shown full size

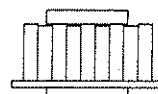

Steering Wheel Adapter

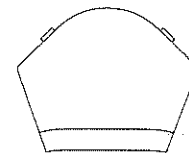

Steering Wheel Insert

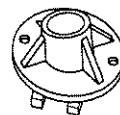

Steering Bushing



(2) Keys

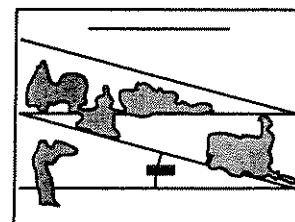

Slope Sheet

# ASSEMBLY

Your new tractor has been assembled at the factory with exception of those parts left unassembled for shipping purposes. To ensure safe and proper operation of your tractor all parts and hardware you assemble must be tightened securely. Use the correct tools as necessary to insure proper tightness.

## TOOLS REQUIRED FOR ASSEMBLY

A socket wrench set will make assembly easier. Standard wrench sizes are listed.

- |                    |                     |
|--------------------|---------------------|
| (1) 5/16" wrench   | (1) 3/4" wrench     |
| (2) 7/16" wrenches | Tire pressure gauge |
| (1) 1/2" wrench    | Utility knife       |
| (1) 9/16" wrench   |                     |

When right or left hand is mentioned in this manual, it means when you are in the operating position (seated behind the steering wheel).

## TO REMOVE TRACTOR FROM CARTON

### UNPACK CARTON

- Remove all accessible loose parts and parts cartons from carton (See page 6).
- Cut, from top to bottom, along lines on all four corners of carton, and lay panels flat.
- Check for any additional loose parts or cartons and remove.

## BEFORE ROLLING TRACTOR OFF SKID

### ATTACH STEERING WHEEL (See Fig. 1)

- Slide the steering bushing over the steering shaft.
- Raise steering shaft forward until screw holes in dash line up with steering bushing. Install two (2) sheet metal screws and tighten securely.
- Position steering boot over steering shaft.
- Place tabs of steering boot over tab slots in dash and push down to secure.
- Slide steering wheel adapter onto upper steering shaft.
- Position front wheels of the tractor so they are pointing straight forward.
- Position steering wheel so cross bars are horizontal (left to right) and slide onto adapter.
- Assemble large flat washer and 3/8-24 locknut and tighten securely.
- Snap steering wheel insert into center of steering wheel.
- Remove protective plastic from tractor hood and grill.

**IMPORTANT: CHECK FOR AND REMOVE ANY STAPLES IN SKID THAT MAY PUNCTURE TIRES WHERE TRACTOR IS TO ROLL OFF SKID.**

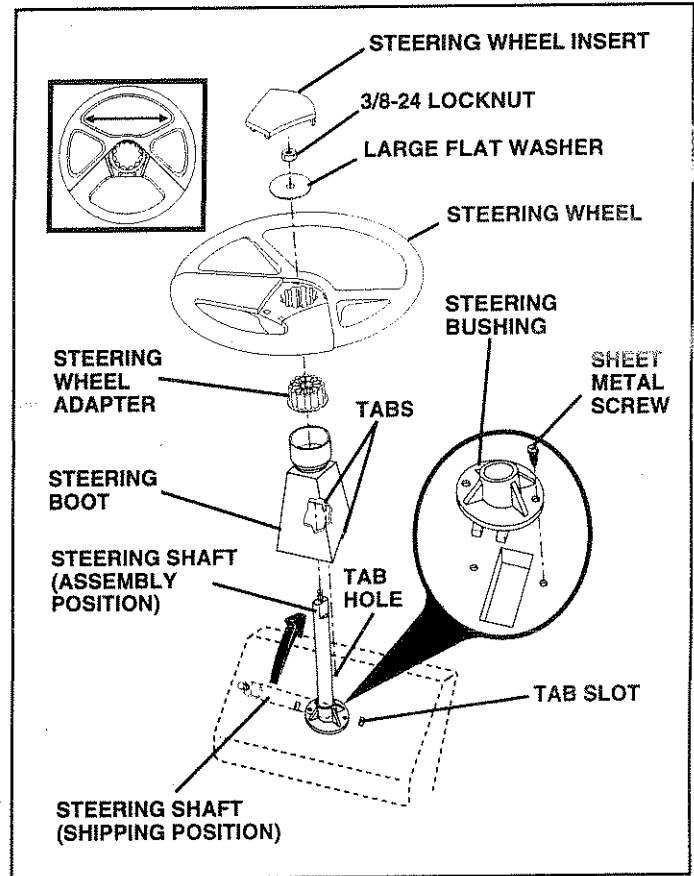

FIG. 1

### TO ROLL TRACTOR OFF SKID (See Fig. 5)

- Press lift lever plunger and raise attachment lift lever to its highest position.
- Release parking brake by depressing clutch/brake pedal.
- Place gearshift lever in neutral (N) position.
- Roll tractor backwards off skid.
- Remove banding holding discharge guard up against tractor.

# ASSEMBLY

## CONNECT BATTERY (See Figs. 2 and 3)



**CAUTION:** Do not short battery terminals. Before connecting battery, remove metal bracelets, wristwatch bands, rings, etc.

Positive terminal must be connected first to prevent sparking from accidental grounding.

- Remove cardboard packing from seat pan and lift seat pan to raised position.
- Open battery box door.
- Remove terminal protective caps and discard.
- If this battery is put into service after month and year indicated on label (label located between terminals) charge battery for minimum of one hour at 6-10 amps.
- First connect RED battery cable to positive (+) terminal with hex bolt, flat washer, lock washer and hex nut as shown. Tighten securely.
- Connect BLACK grounding cable to negative (-) terminal with remaining hex bolt, flat washer, lock washer and hex nut. Tighten securely.
- Close battery box door.

Open battery box door for:

- Inspection for secure connections (to tighten hardware).
- Inspection for corrosion.
- Testing battery.
- Jumping (if required).
- Periodic charging.

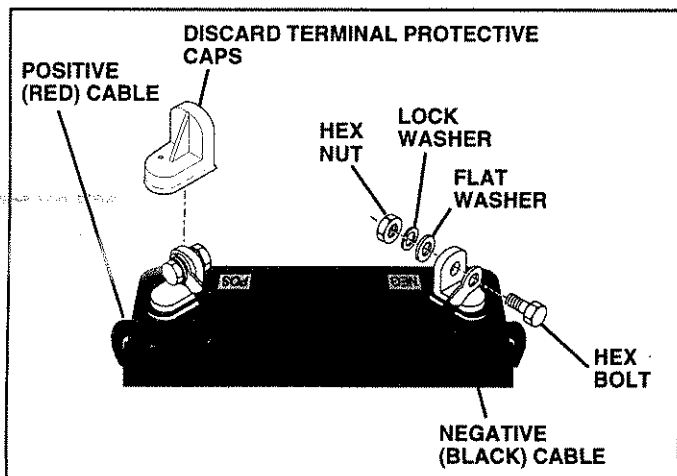

FIG. 2

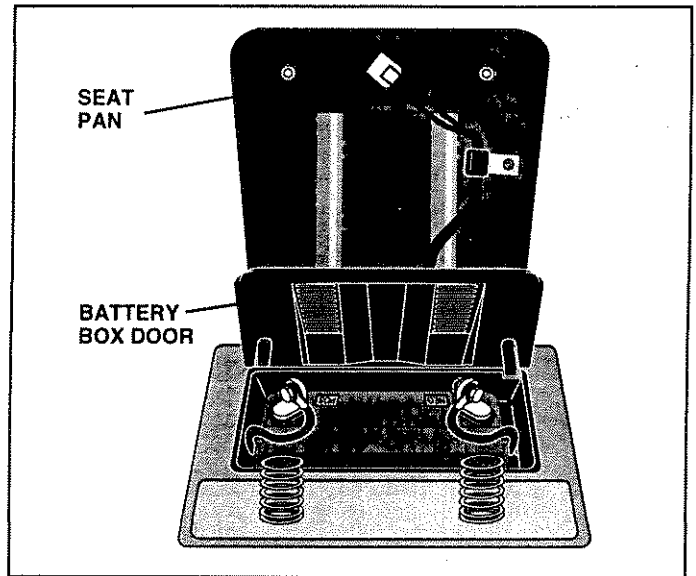

FIG. 3

## INSTALL SEAT (See Fig. 4)

Adjust seat before tightening adjustment bolt.

- Remove cardboard packing on seat pan.
- Place seat on seat pan and assemble shoulder bolt.
- Assemble adjustment bolt, lock washer and flat washer loosely. Do not tighten.
- Tighten shoulder bolt securely.
- Lower seat into operating position and sit on seat.
- Slide seat until a comfortable position is reached which allows you to press clutch/brake pedal all the way down.
- Get off seat without moving its adjusted position.
- Raise seat and tighten adjustment bolt securely.

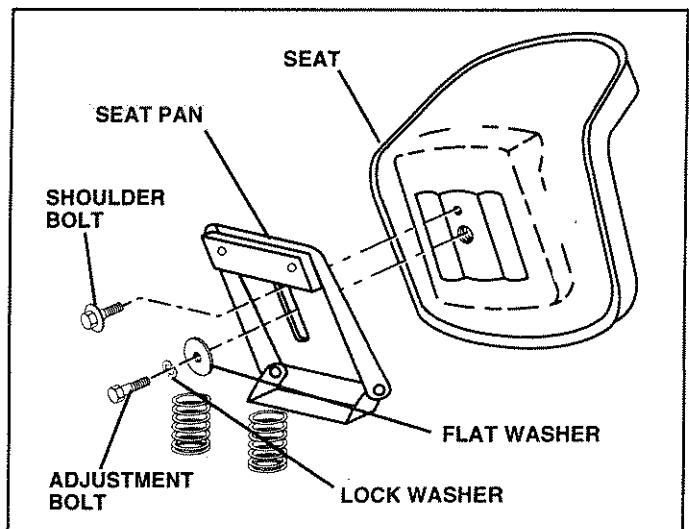

FIG. 4



---

# ASSEMBLY

---

## CHECK TIRE PRESSURE

The tires on your tractor were overinflated at the factory for shipping purposes. Correct tire pressure is important for best cutting performance.

- Reduce tire pressure to PSI shown in "PRODUCT SPECIFICATIONS" on page 3 of this manual.

## CHECK DECK LEVELNESS

For best cutting results, mower housing should be properly leveled. See "TO LEVEL MOWER HOUSING" in the Service and Adjustments section of this manual.

## CHECK FOR PROPER POSITION OF ALL BELTS

See the figures that are shown for replacing motion and mower blade drive belts in the Service and Adjustments section of this manual. Verify that the belts are routed correctly.

## CHECK BRAKE SYSTEM

After you learn how to operate your tractor, check to see that the brake is properly adjusted. See "TO ADJUST BRAKE" in the Service and Adjustments section of this manual.

## ✓ CHECKLIST

*BEFORE YOU OPERATE AND ENJOY YOUR NEW TRACTOR, WE WISH TO ASSURE THAT YOU RECEIVE THE BEST PERFORMANCE AND SATISFACTION FROM THIS QUALITY PRODUCT.*

*PLEASE REVIEW THE FOLLOWING CHECKLIST:*

- ✓ All assembly instructions have been completed.
- ✓ No remaining loose parts in carton.
- ✓ Battery is properly prepared and charged. (Minimum 1 hour at 6 amps).
- ✓ Seat is adjusted comfortably and tightened securely.
- ✓ All tires are properly inflated. (For shipping purposes, the tires were overinflated at the factory).
- ✓ Be sure mower deck is properly leveled side-to-side/front-to-rear for best cutting results. (Tires must be properly inflated for leveling).
- ✓ Check mower and drive belts. Be sure they are routed properly around pulleys and inside all belt keepers.
- ✓ Check wiring. See that all connections are still secure and wires are properly clamped.

*WHILE LEARNING HOW TO USE YOUR TRACTOR, PAY EXTRA ATTENTION TO THE FOLLOWING IMPORTANT ITEMS:*

- ✓ Engine oil is at proper level.
- ✓ Fuel tank is filled with fresh, clean, regular unleaded gasoline.
- ✓ Become familiar with all controls - their location and function. Operate them before you start the engine.
- ✓ Be sure brake system is in safe operating condition.

# OPERATION

These symbols may appear on your tractor or in literature supplied with the product. Learn and understand their meaning.



BATTERY



CAUTION OR WARNING



REVERSE



FORWARD



FAST



SLOW



ENGINE ON



ENGINE OFF



OIL PRESSURE



CLUTCH



LIGHTS ON



LIGHTS OFF



FUEL



CHOKE

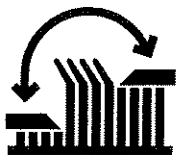

MOWER HEIGHT

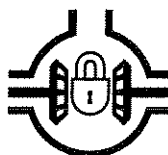

DIFFERENTIAL LOCK



PARKING BRAKE LOCKED



UNLOCKED



MOWER LIFT

**R**

REVERSE

**N**

NEUTRAL

**H**

HIGH

**L**

LOW



PARKING BRAKE

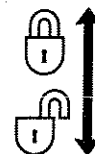

ATTACHMENT CLUTCH ENGAGED



ATTACHMENT CLUTCH DISENGAGED

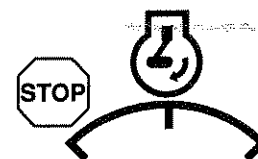

IGNITION



DANGER, KEEP HANDS AND FEET AWAY

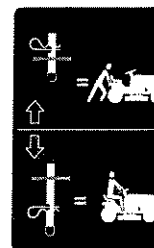

HYDROSTATIC FREE WHEEL  
(Hydro Models only)

# OPERATION

## KNOW YOUR TRACTOR

### READ THIS OWNER'S MANUAL AND SAFETY RULES BEFORE OPERATING YOUR TRACTOR

Compare the illustrations with your tractor to familiarize yourself with the locations of various controls and adjustments. Save this manual for future reference.

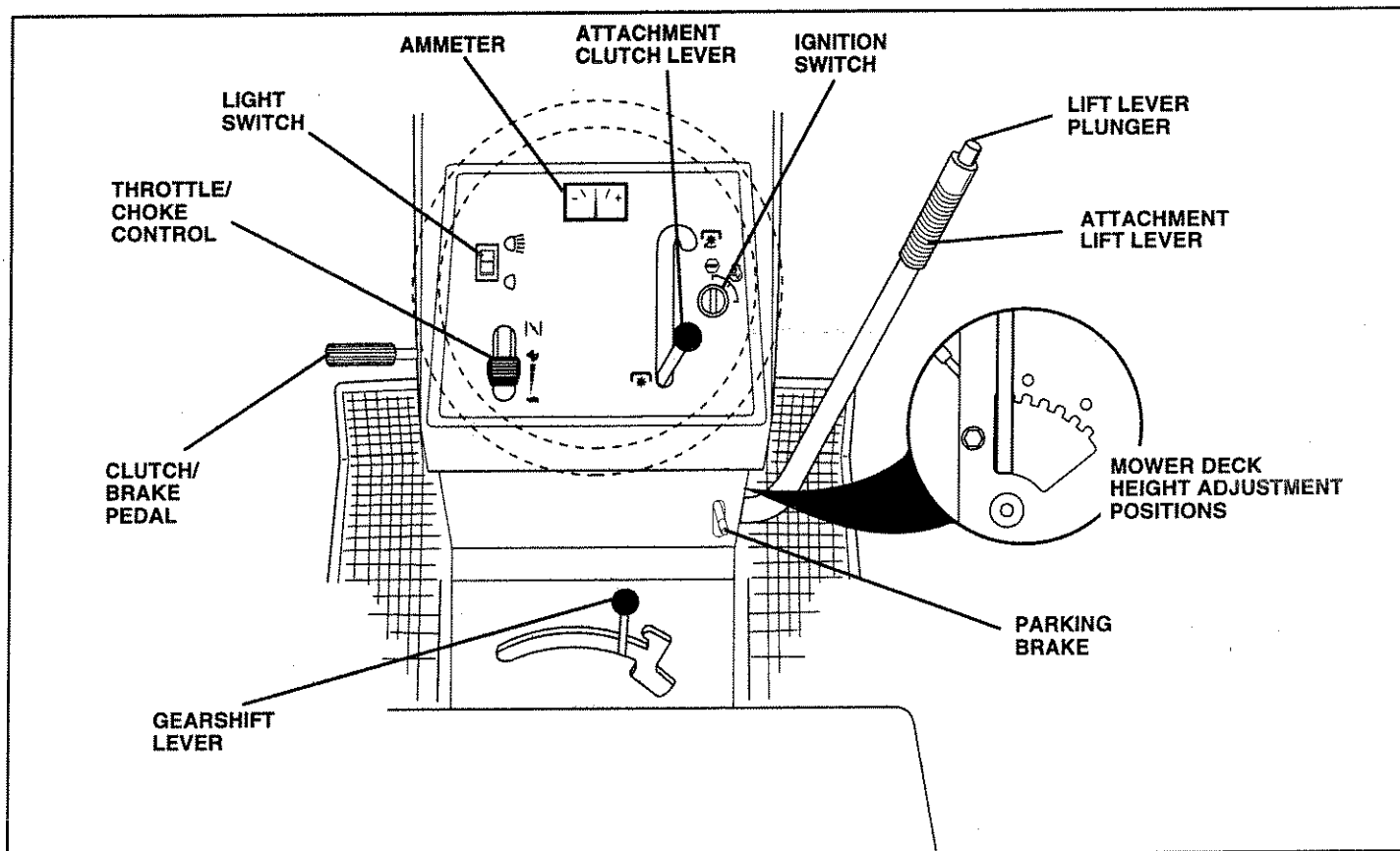

FIG. 5

Our tractors conform to the safety standards of the American National Standards Institute.

**ATTACHMENT CLUTCH LEVER:** Used to engage the mower blades, or other attachments mounted to your tractor.

**LIGHT SWITCH:** Turns the headlights on and off.

**THROTTLE/CHOKE CONTROL:** Used for starting and controlling engine speed.

**CLUTCH/BRAKE PEDAL:** Used for declutching and braking the tractor and starting the engine.

**PARKING BRAKE:** Locks clutch/brake pedal into the brake position.

**GEARSHIFT LEVER:** Selects the speed and direction of tractor.

**ATTACHMENT LIFT LEVER:** Used to raise, lower, and adjust the mower deck or other attachments mounted to your tractor.

**LIFT LEVER PLUNGER:** Used to release attachment lift lever when changing its position.

**IGNITION SWITCH:** Used for starting and stopping the engine.

**AMMETER:** Indicates battery charging (+) or discharging (-).

# OPERATION



The operation of any tractor can result in foreign objects thrown into the eyes, which can result in severe eye damage. Always wear safety glasses or eye shields while operating your tractor or performing any adjustments or repairs. We recommend a wide vision safety mask over the spectacles or standard safety glasses.

## HOW TO USE YOUR TRACTOR

### TO SET PARKING BRAKE (See Fig. 6)

Your tractor is equipped with an operator presence sensing switch. When engine is running, any attempt by the operator to leave the seat without first setting the parking brake will shut off the engine.

- Depress clutch/brake pedal into full "BRAKE" position and hold.
- Place parking brake lever in "ENGAGED" position and release pressure from clutch/brake pedal. Pedal should remain in "BRAKE" position. Make sure parking brake will hold tractor secure.

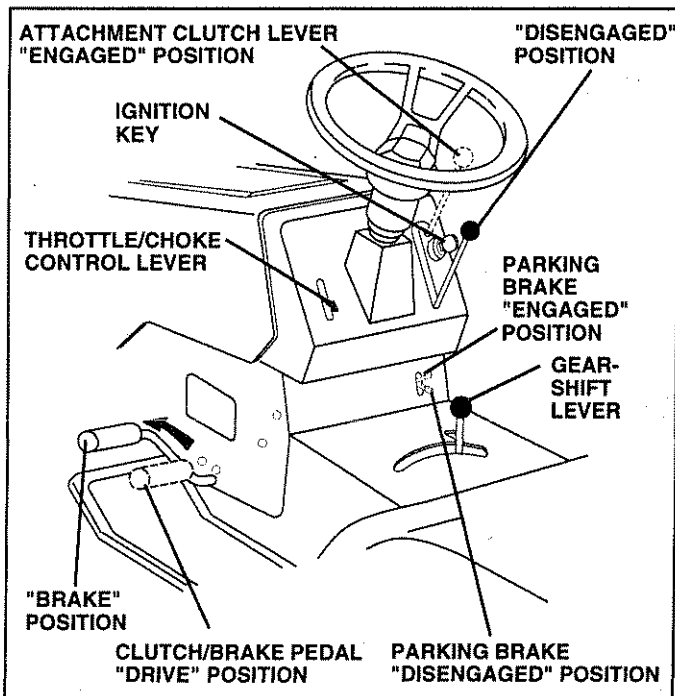

FIG. 6

### STOPPING (See Fig. 6)

#### MOWER BLADES -

- Move attachment clutch lever to "DISENGAGED" position.

#### GROUND DRIVE -

- Depress clutch/brake pedal into full "BRAKE" position.
- Move gearshift lever to neutral (N) position.

#### ENGINE -

- Move throttle control to slow (☷) position.

**NOTE:** Failure to move throttle control to slow (☷) position and allowing engine to idle before stopping may cause engine to "backfire".

- Turn ignition key to "OFF" position and remove key. Always remove key when leaving tractor to prevent unauthorized use.
- Never use choke to stop engine.

**NOTE:** Under certain conditions when tractor is standing idle with the engine running, hot engine exhaust gases may cause "browning" of grass. To eliminate this possibility, always stop engine when stopping tractor on grass areas.



**CAUTION:** Always stop tractor completely, as described above, before leaving the operator's position; to empty grass catcher, etc.

### TO USE THROTTLE CONTROL (See Fig. 6)

Always operate engine at full throttle.

- Operating engine at less than full throttle reduces the battery charging rate.
- Full throttle offers the best bagging and mower performance.

### TO MOVE FORWARD AND BACKWARD (See Fig. 6)

The direction and speed of movement is controlled by the gearshift lever.

- Start tractor with clutch/brake pedal depressed and gearshift lever in neutral (N) position.
- Move gearshift lever to desired position.
- Slowly release clutch/brake pedal to start movement.

**IMPORTANT:** BRING TRACTOR TO A COMPLETE STOP BEFORE SHIFTING OR CHANGING GEARS. FAILURE TO DO SO WILL SHORTEN THE USEFUL LIFE OF YOUR TRANSAXLE.

### TO ADJUST MOWER CUTTING HEIGHT (See Fig. 5)

The position of the attachment lift lever determines the cutting height.

- Grasp lift lever.
- Press plunger with thumb and move lever to desired position.

The cutting height range is approximately 1-1/2 to 4". The heights are measured from the ground to the blade tip with the engine not running. These heights are approximate and may vary depending upon soil conditions, height of grass and types of grass being mowed.

- The average lawn should be cut to approximately 2-1/2 inches during the cool season and to over 3 inches during hot months. For healthier and better looking lawns, mow often and after moderate growth.
- For best cutting performance, grass over 6 inches in height should be mowed twice. Make the first cut relatively high; the second to desired height.

# OPERATION

## TO OPERATE MOWER (See Fig. 7)

Your tractor is equipped with an operator presence sensing switch. Any attempt by the operator to leave the seat with the engine running and the attachment clutch engaged will shut off the engine.

- Select desired height of cut.
- Start mower blades by engaging attachment clutch control.
- TO STOP MOWER BLADES - disengage attachment clutch control.



**CAUTION: Do not operate the mower without either the entire grass catcher, on mowers so equipped, or the discharge guard in place.**

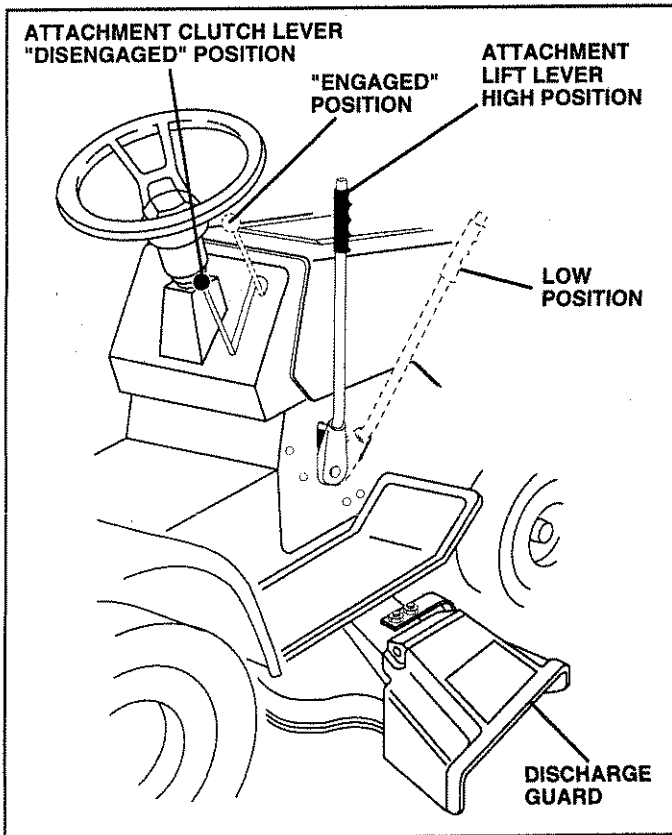

FIG. 7

## TO OPERATE ON HILLS



**CAUTION: Do not drive up or down hills with slopes greater than 15° and do not drive across any slope.**

- Choose the slowest speed before starting up or down hills.
- Avoid stopping or changing speed on hills.
- If slowing is necessary, move throttle control lever to slower position.
- If stopping is absolutely necessary, push clutch/brake pedal quickly to brake position and engage parking brake.
- Move gearshift lever to 1st gear. Be sure you have allowed room for tractor to roll slightly as you restart movement.
- To restart movement, slowly release parking brake and clutch/brake pedal.
- Make all turns slowly.

## TO TRANSPORT

- Raise attachment lift to highest position with attachment lift control.
- When pushing or towing your tractor, be sure gearshift lever is in neutral (N) position.
- Do not push or tow tractor at more than five (5) MPH.

**NOTE:** To protect hood from damage when transporting your tractor on a truck or a trailer, be sure hood is closed and secured to tractor. Use an appropriate means of tying hood to tractor (rope, cord, etc.).

## BEFORE STARTING THE ENGINE

### CHECK ENGINE OIL LEVEL (See Fig. 12)

- The engine in your tractor has been shipped, from the factory, already filled with summer weight oil.
- Check engine oil with tractor on level ground.
- Remove oil fill cap/dipstick and wipe clean, reinsert the dipstick and screw cap tight, wait for a few seconds, remove and read oil level. If necessary, add oil until "FULL" mark on dipstick is reached. Do not overfill.
- For cold weather operation you should change oil for easier starting (See "OIL VISCOSITY CHART" in the Customer Responsibilities section of this manual).
- To change engine oil, see the Customer Responsibilities section in this manual.

# OPERATION

## ADD GASOLINE

- Fill fuel tank. Use fresh, clean, regular unleaded gasoline with a minimum of 87 octane. (Use of leaded gasoline will increase carbon and lead oxide deposits and reduce valve life). Do not mix oil with gasoline. Purchase fuel in quantities that can be used within 30 days to assure fuel freshness.

**IMPORTANT:** WHEN OPERATING IN TEMPERATURES BELOW 32°F(0°C), USE FRESH, CLEAN WINTER GRADE GASOLINE TO HELP INSURE GOOD COLD WEATHER STARTING.

**WARNING:** Experience indicates that alcohol blended fuels (called gasohol or using ethanol or methanol) can attract moisture which leads to separation and formation of acids during storage. Acidic gas can damage the fuel system of an engine while in storage. To avoid engine problems, the fuel system should be emptied before storage of 30 days or longer. Drain the gas tank, start the engine and let it run until the fuel lines and carburetor are empty. Use fresh fuel next season. See Storage Instructions for additional information. Never use engine or carburetor cleaner products in the fuel tank or permanent damage may occur.



**CAUTION:** Fill to bottom of gas tank filler neck. Do not overfill. Wipe off any spilled oil or fuel. Do not store, spill or use gasoline near an open flame.

## TO START ENGINE (See Fig. 6)

This engine on this product is designed for maximum performance and life if operated with the choke (| \ |) fully open and the throttle control in the fast (☛) position. To open the choke fully requires an engine warm-up period of several seconds to several minutes, depending on the temperature.

After starting the engine, first open the choke slowly until the engine just begins to run smoothly. Then open the choke in small steps, allowing the engine to accept small changes in speed and load until the choke is fully open. During engine warm-up, the equipment can be operated.

When starting engine for the first time or if engine has run out of fuel, it will take extra cranking time to move fuel from the tank to the engine.

- Depress clutch/brake pedal and set parking brake.
- Place gearshift lever in neutral (N) position.
- Move attachment clutch to "DISENGAGED" position.
- Move throttle control lever to choke (| \ |) position for cold engine start. For warm engine start, move throttle control to fast (☛) position.
- Insert key into ignition and turn key clockwise to "START" position and release key as soon as engine starts. Do not run starter continuously for more than fifteen seconds per minute. If engine does not start after several attempts, move throttle control to fast (☛) position, wait a few minutes and try again.
- When engine starts, move throttle control to desired position.
- Allow engine to warm up for a few minutes before engaging drive or attachments.

**NOTE:** If at a high altitude (above 3000 feet) or in cold temperatures (below 32°F), the carburetor fuel mixture may need to be adjusted for best engine performance. See "TO ADJUST CARBURETOR" in the Service and Adjustments section of this manual.

## MOWING TIPS

- Tire chains cannot be used when the mower housing is attached to tractor.
- Mower should be properly leveled for best mowing performance. See "TO LEVEL MOWER HOUSING" in the Service and Adjustments section of this manual.
- The left hand side of mower should be used for trimming.
- Drive so that clippings are discharged onto the area that has been cut. Have the cut area to the right of the machine. This will result in a more even distribution of clippings and more uniform cutting.
- When mowing large areas, start by turning to the right so that clippings will discharge away from shrubs, fences, driveways, etc. After one or two rounds, mow in the opposite direction making left hand turns until finished (See Fig. 8).
- If grass is extremely tall, it should be mowed twice to reduce load and possible fire hazard from dried clippings. Make first cut relatively high; the second to the desired height.
- Do not mow grass when it is wet. Wet grass will plug mower and leave undesirable clumps. Allow grass to dry before mowing.
- Always operate engine at full throttle when mowing to assure better mowing performance and proper discharge of material. Regulate ground speed by selecting a low enough gear to give the mower cutting performance as well as the quality of cut desired.
- When operating attachments, select a ground speed that will suit the terrain and give best performance of the attachment being used.

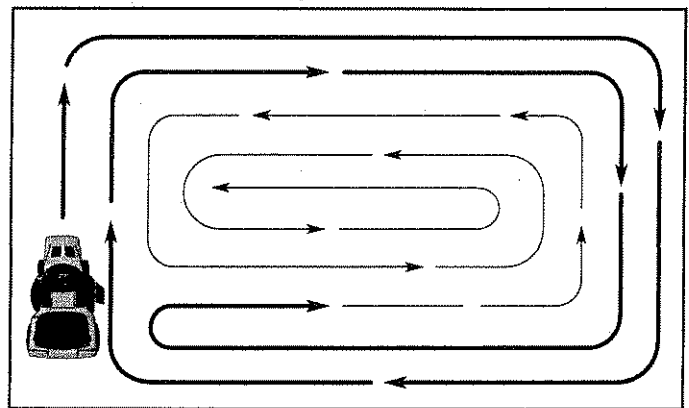

FIG. 8

# CUSTOMER RESPONSIBILITIES

MAINTENANCE SCHEDULE FILL IN DATES AS YOU COMPLETE REGULAR SERVICE		SERVICE DATES																	
		BEFORE EACH USE	FIRST 2 HOURS	EVERY 8 HOURS	EVERY 25 HOURS	EVERY 50 HOURS	EVERY 100 HOURS	BEFORE STORAGE											
TRACTOR	Check Brake Operation	✓		✓															
	Check Tire Pressure	✓		✓															
	Check for Loose Fasteners	✓						✓ <sub>7</sub>		✓									
	Sharpen/Replace Mower Blades					✓ <sub>4</sub>													
	Lubrication Chart					✓				✓									
	Check Battery Level/Recharge					✓ <sub>6</sub>													
	Clean Battery and Terminals					✓					✓								
	Check Transaxle Cooling					✓													
	Adjust Blade Belt(s) Tension								✓ <sub>5</sub>										
	Adjust Motion Drive Belt(s) Tension								✓ <sub>5</sub>										
	ENGINE	Check Engine Oil Level	✓		✓														
Change Engine Oil			✓		✓ <sub>1,2,3</sub>					✓									
Clean Air Filter					✓ <sub>2</sub>														
Clean Air Screen					✓ <sub>2</sub>														
Inspect Muffler/Spark Arrester							✓												
Replace Oil Filter (If equipped)									✓ <sub>1,2</sub>										
Clean Engine Cooling Fins									✓ <sub>2</sub>										
Replace Spark Plug									✓		✓								
Replace Air Filter Paper Cartridge									✓ <sub>2</sub>										
Replace Fuel Filter										✓									

- 1 - Change more often when operating under a heavy load or in high ambient temperatures.
- 2 - Service more often when operating in dirty or dusty conditions.
- 3 - If equipped with oil filter, change oil every 50 hours.
- 4 - Replace blades more often when mowing in sandy soil.

- 5 - If equipped with adjustable system.
- 6 - Not required if equipped with maintenance-free battery.
- 7 - Tighten front axle pivot bolt to 35 ft.-lbs. maximum. Do not overtighten.

## GENERAL RECOMMENDATIONS

The warranty on this tractor does not cover items that have been subjected to operator abuse or negligence. To receive full value from the warranty, operator must maintain tractor as instructed in this manual.

Some adjustments will need to be made periodically to properly maintain your tractor.

All adjustments in the Service and Adjustments section of this manual should be checked at least once each season.

- Once a year you should replace the spark plug, clean or replace air filter, and check blades and belts for wear. A new spark plug and clean air filter assure proper air-fuel mixture and help your engine run better and last longer.

## BEFORE EACH USE

- Check engine oil level.
- Check brake operation.
- Check tire pressure.
- Check for loose fasteners.

## LUBRICATION CHART

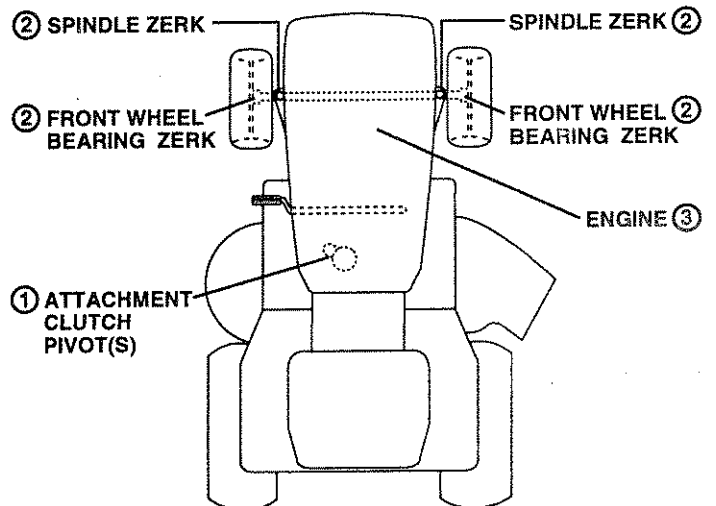

- ① SAE 30 OR 10W30 MOTOR OIL
- ② GENERAL PURPOSE GREASE
- ③ REFER TO CUSTOMER RESPONSIBILITIES "ENGINE" SECTION

**IMPORTANT:** DO NOT OIL OR GREASE THE PIVOT POINTS WHICH HAVE SPECIAL NYLON BEARINGS. VISCOUS LUBRICANTS WILL ATTRACT DUST AND DIRT THAT WILL SHORTEN THE LIFE OF THE SELF-LUBRICATING BEARINGS. IF YOU FEEL THEY MUST BE LUBRICATED, USE ONLY A DRY, POWDERED GRAPHITE TYPE LUBRICANT SPARINGLY.

# CUSTOMER RESPONSIBILITIES

## TRACTOR

Always observe safety rules when performing any maintenance.

## BRAKE OPERATION

If tractor requires more than six (6) feet stopping distance at high speed in highest gear, then brake must be adjusted. (See "TO ADJUST BRAKE" in the Service and Adjustments section of this manual).

## TIRES

- Maintain proper air pressure in all tires (See "PRODUCT SPECIFICATIONS" on page 3 of this manual).
- Keep tires free of gasoline, oil, or insect control chemicals which can harm rubber.
- Avoid stumps, stones, deep ruts, sharp objects and other hazards that may cause tire damage.

## BLADE CARE

For best results mower blades must be kept sharp. Replace bent or damaged blades.

## BLADE REMOVAL (See Fig. 9)

- Raise mower to highest position to allow access to blades.
- Remove hex bolt, lock washer and flat washer securing blade.
- Install new or resharpened blade with trailing edge up towards deck as shown.
- Reassemble hex bolt, lock washer and flat washer in exact order as shown.
- Tighten bolt securely (30-35 Ft. Lbs. torque).

**IMPORTANT:** BLADE BOLT IS GRADE 8 HEAT TREATED.

**NOTE:** We do not recommend sharpening blade - but if you do, be sure the blade is balanced.

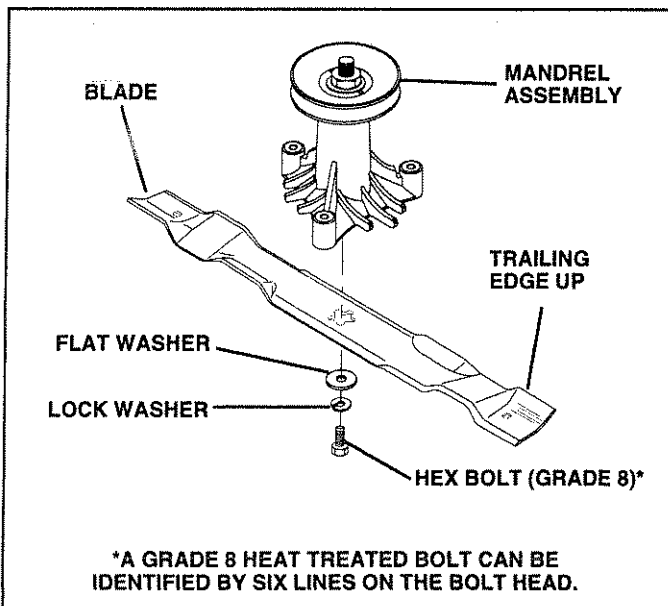

FIG. 9

## TO SHARPEN BLADE (See Fig. 10)

Care should be taken to keep the blade balanced. An unbalanced blade will cause excessive vibration and eventual damage to mower and engine.

- The blade can be sharpened with a file or on a grinding wheel. Do not attempt to sharpen while on the mower.
- To check blade balance, you will need a 5/8" diameter steel bolt, pin, or a cone balancer. (When using a cone balancer, follow the instructions supplied with balancer).
- Slide blade on to an unthreaded portion of the steel bolt or pin and hold the bolt or pin parallel with the ground. If blade is balanced, it should remain in a horizontal position. If either end of the blade moves downward, sharpen the heavy end until the blade is balanced.

**NOTE:** Do not use a nail for balancing blade. The lobes of the center hole may appear to be centered, but are not.

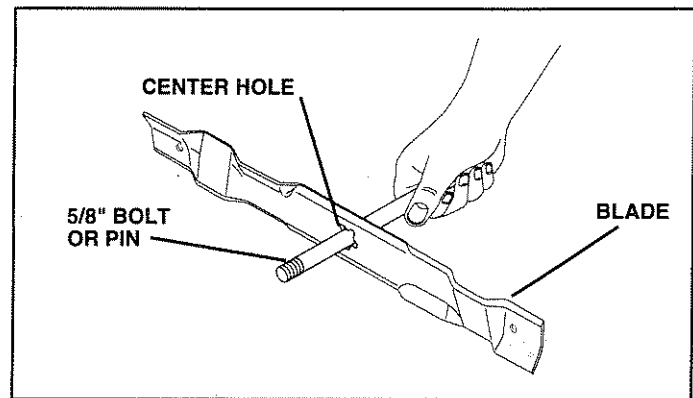

FIG. 10

## BATTERY

Your tractor has a battery charging system which is sufficient for normal use. However, periodic charging of the battery with an automotive charger will extend its life.

- Keep battery and terminals clean.
- Keep battery bolts tight.
- Keep small vent holes open.
- Recharge at 6-10 amperes for 1 hour.

## TO CLEAN BATTERY AND TERMINALS

Corrosion and dirt on the battery and terminals can cause the battery to "leak" power.

- Open battery box door.
- Disconnect BLACK battery cable first then RED battery cable and remove battery from tractor.
- Rinse the battery with plain water and dry.
- Clean terminals and battery cable ends with wire brush until bright.
- Coat terminals with grease or petroleum jelly.
- Reinstall battery (See "CONNECT BATTERY" in the Assembly section of this manual).



# CUSTOMER RESPONSIBILITIES

## V-BELTS

Check V-belts for deterioration and wear after 100 hours of operation and replace if necessary. The belts are not adjustable. Replace belts if they begin to slip from wear.

## TRANSAXLE COOLING

Keep transaxle free from build-up of dirt and chaff which can restrict cooling.

## ENGINE

### LUBRICATION

Only use high quality detergent oil rated with API service classification SF or SG. Select the oil's SAE viscosity grade according to your expected operating temperature.

**NOTE:** Although multi-viscosity oils (5W30, 10W30 etc.) improve starting in cold weather, these multi-viscosity oils will result in increased oil consumption when used above 32°F. Check your engine oil level more frequently to avoid possible engine damage from running low on oil.

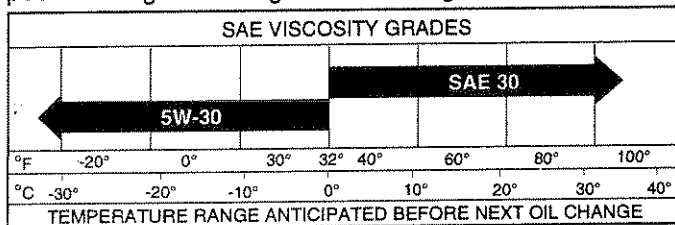

FIG. 11

Change the oil after the first two hours of operation and every 25 hours thereafter or at least once a year if the tractor is not used for 25 hours in one year.

Check the crankcase oil level before starting the engine and after each eight (8) hours of operation. Tighten oil fill cap/dipstick securely each time you check the oil level.

### TO CHANGE ENGINE OIL (See Figs. 11 and 12)

Determine temperature range expected before oil change. All oil must meet API service classification SF or SG.

- Be sure tractor is on level surface.
- Oil will drain more freely when warm.
- Catch oil in a suitable container.
- Remove oil fill cap/dipstick. Be careful not to allow dirt to enter the engine when changing oil.
- Remove drain plug.
- After oil has drained completely, replace oil drain plug and tighten securely.
- Refill engine with oil through oil fill dipstick tube. Pour slowly. Do not overfill. For approximate capacity see "PRODUCT SPECIFICATIONS" on page 3 of this manual.
- Use gauge on oil fill cap/dipstick for checking level. Be sure dipstick cap is tightened securely for accurate reading. Keep oil at "FULL" line on dipstick.

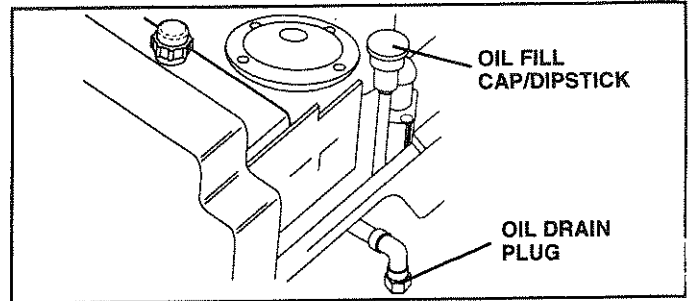

FIG. 12

### AIR FILTER (See Fig. 13)

Your engine will not run properly using a dirty air filter. Clean the foam pre-cleaner after every 25 hours of operation or every season. Service paper cartridge every 100 hours of operation or every season, whichever occurs first.

Service air cleaner more often under dusty conditions.

- Remove knob(s) and cover.

### TO SERVICE PRE-CLEANER

- Slide foam pre-cleaner off cartridge.
- Wash it in liquid detergent and water.
- Squeeze it dry in a clean cloth.
- Saturate it in engine oil. Wrap it in clean, absorbent cloth and squeeze to remove excess oil.
- If very dirty or damaged, replace pre-cleaner.
- Reinstall pre-cleaner over cartridge.
- Reinstall cover and secure with knob(s).

### TO SERVICE CARTRIDGE

- Remove cartridge nut.
- Carefully remove cartridge to prevent debris from entering carburetor. Clean base carefully to prevent debris from entering carburetor.
- Clean cartridge by tapping gently on flat surface. If very dirty or damaged, replace cartridge.
- Reinstall cartridge, nut, precleaner, cover and secure with knob(s).

**IMPORTANT:** PETROLEUM SOLVENTS, SUCH AS KEROSENE, ARE NOT TO BE USED TO CLEAN THE CARTRIDGE. THEY MAY CAUSE DETERIORATION OF THE CARTRIDGE. DO NOT OIL CARTRIDGE. DO NOT USE PRESSURIZED AIR TO CLEAN OR DRY CARTRIDGE.

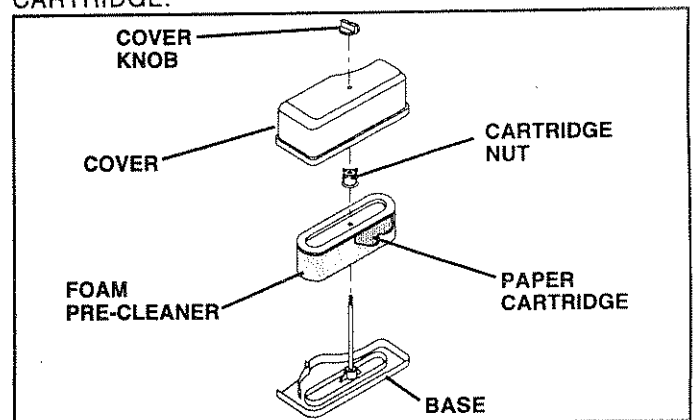

FIG. 13

# CUSTOMER RESPONSIBILITIES

## CLEAN AIR SCREEN (See Fig. 14)

Air screen must be kept free of dirt and chaff to prevent engine damage from overheating. Clean with a wire brush or compressed air to remove dirt and stubborn dried gum fibers.

## ENGINE COOLING FINS (See Fig. 14)

Remove any dust, dirt or oil from engine cooling fins to prevent engine damage from overheating.

- Remove screws from blower housing and lift housing and oil fill tube assembly off engine.
- Cover oil fill opening to prevent entry of dirt.
- Remove the screws securing the starter housing and lift housing off engine.
- Use compressed air or stiff bristle brush to thoroughly clean engine cooling fins.
- To reassemble, reverse above procedure.

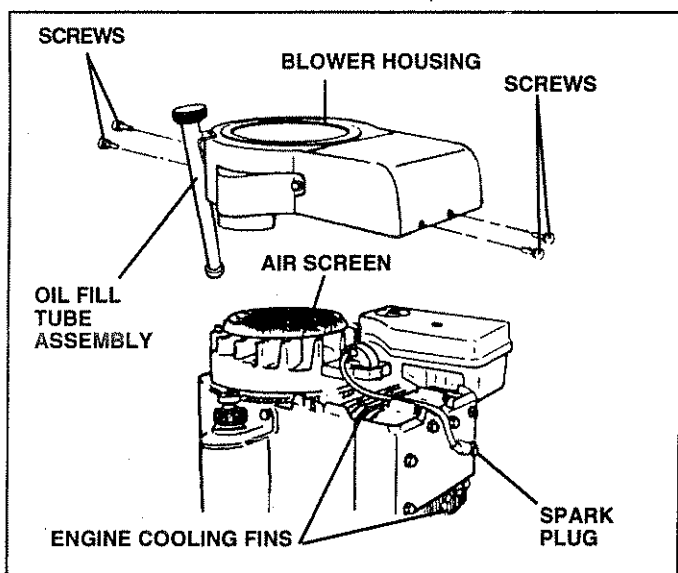

FIG. 14

## MUFFLER

Inspect and replace corroded muffler and spark arrester (if equipped) as it could create a fire hazard and/or damage.

## SPARK PLUGS

Replace spark plugs at the beginning of each mowing season or after every 100 hours of operation, whichever occurs first. Spark plug type and gap setting are shown in "PRODUCT SPECIFICATIONS" on page 3 of this manual.

## IN-LINE FUEL FILTER (See Fig. 15)

The fuel filter should be replaced once each season. If fuel filter becomes clogged, obstructing fuel flow to carburetor, replacement is required.

- With engine cool, remove filter and plug fuel line sections.
- Place new fuel filter in position in fuel line with arrow pointing towards carburetor.
- Be sure there are no fuel line leaks and clamps are properly positioned.
- Immediately wipe up any spilled gasoline.

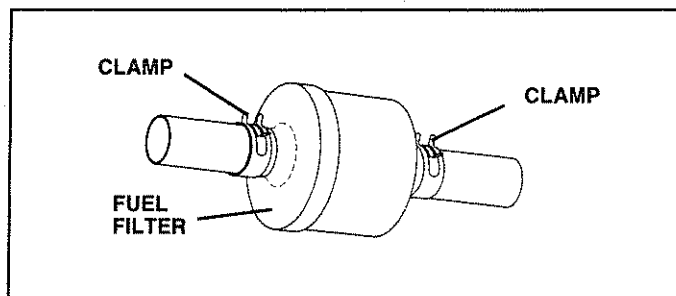

FIG. 15

## CLEANING

- Clean engine, battery, seat, finish, etc. of all foreign matter.
- Keep finished surfaces and wheels free of all gasoline, oil, etc.
- Protect painted surfaces with automotive type wax.

We do not recommend using a garden hose to clean your tractor unless the electrical system, muffler, air filter and carburetor are covered to keep water out. Water in engine can result in a shortened engine life.

# SERVICE AND ADJUSTMENTS



## CAUTION: BEFORE PERFORMING ANY SERVICE OR ADJUSTMENTS:

- Depress clutch/brake pedal fully and set parking brake.
- Place gearshift lever in neutral (N) position.
- Place attachment clutch in "DISENGAGED" position.
- Turn ignition key "OFF" and remove key.
- Make sure the blades and all moving parts have completely stopped.
- Disconnect spark plug wire from spark plug and place wire where it cannot come in contact with plug.

## TO REMOVE MOWER (See Fig. 16)

Mower will be easier to remove from the right side of tractor.

- Place attachment clutch in "DISENGAGED" position.
- Move attachment lift lever forward to lower mower to its lowest position.
- Roll belt off engine pulley.
- Disconnect clutch rod from clutch lever by removing retainer spring.
- Disconnect anti-sway bar from chassis bracket by removing retainer spring.
- Disconnect suspension arms from rear deck brackets by removing retainer springs.
- Disconnect front links from deck by removing retainer springs.
- Raise lift lever to raise suspension arms. Slide mower out from under tractor.

**IMPORTANT:** IF AN ATTACHMENT OTHER THAN THE MOWER IS TO BE MOUNTED TO THE TRACTOR, THE R.H. AND L.H. SUSPENSION ARMS MUST BE REMOVED FROM TRACTOR.

## TO INSTALL MOWER (See Fig. 16)

- Raise attachment lift lever to its highest position.
- Slide mower under tractor with discharge guard to right side of tractor.
- Lower lift lever to its lowest position.
- Install mower in reverse order of removal instructions.

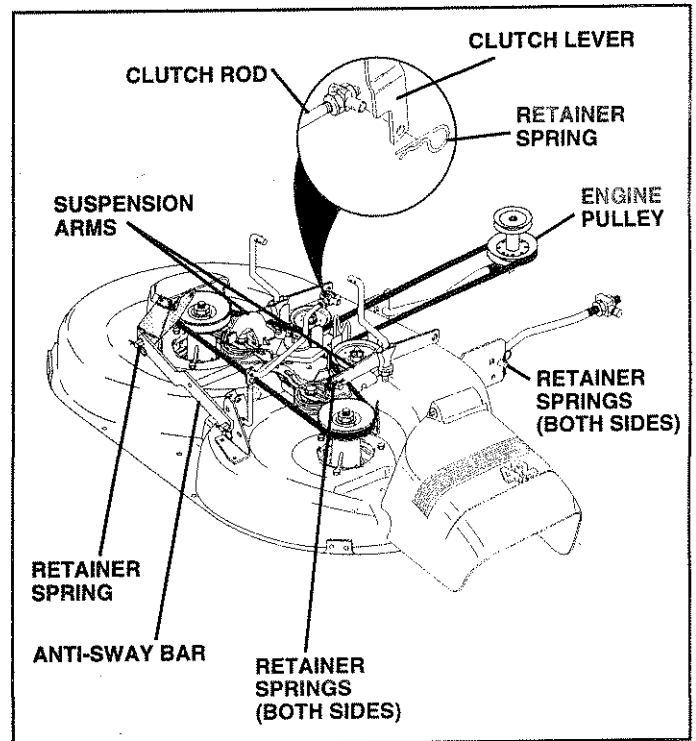

FIG. 16

# SERVICE AND ADJUSTMENTS

## TO LEVEL MOWER HOUSING

Adjust the mower while tractor is parked on level ground or driveway. Make sure tires are properly inflated (See "PRODUCT SPECIFICATIONS" on page 3 of this manual). If tires are over or underinflated, you will not properly adjust your mower.

### SIDE-TO-SIDE ADJUSTMENT (See Figs. 17 and 18)

- Raise mower to its highest position.
- At the midpoint of both sides of mower, measure height from bottom edge of mower to ground. Distance "A" on both sides of mower should be the same or within 1/4" of each other.
- If adjustment is necessary, make adjustment on one side of mower only.
- To raise one side of mower, tighten lift link adjustment nut on that side.
- To lower one side of mower, loosen lift link adjustment nut on that side.

**NOTE:** Each full turn of adjustment nut will change mower height about 1/8".

- Recheck measurements after adjusting.

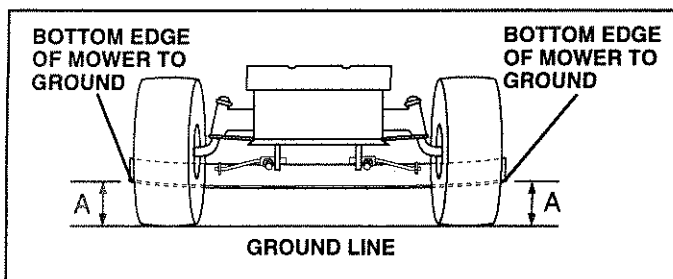

FIG. 17

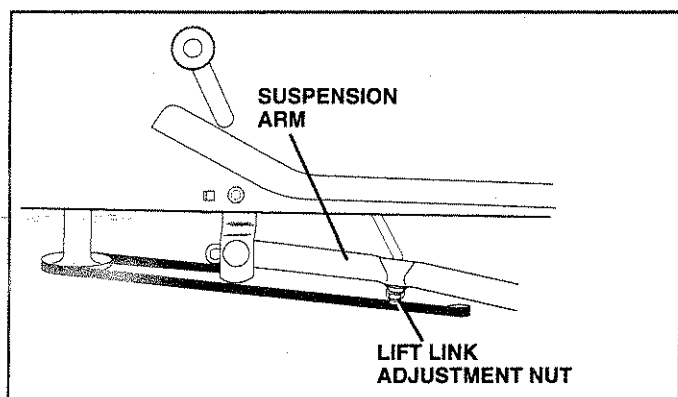

FIG. 18

### FRONT-TO-BACK ADJUSTMENT (See Figs. 19 and 20)

**IMPORTANT:** DECK MUST BE LEVEL SIDE-TO-SIDE. IF THE FOLLOWING FRONT-TO-BACK ADJUSTMENT IS NECESSARY, BE SURE TO ADJUST BOTH FRONT LINKS EQUALLY SO MOWER WILL STAY LEVEL SIDE-TO-SIDE.

To obtain the best cutting results, the mower housing should be adjusted so that the front is approximately 1/4" to 3/4" lower than the rear when the mower is in its highest position.

Check adjustment on right side of tractor. Measure distance "D" directly in front and behind the mandrel at bottom edge of mower housing as shown.

- Before making any necessary adjustments, check that both front links are equal in length. Both links should be approximately 10-3/8".
- If links are not equal in length, adjust one link to same length as other link.
- To lower front of mower loosen nut "E" on both front links an equal number of turns.
- When distance "D" is 1/4" to 3/4" lower at front than rear, tighten nuts "F" against trunnion on both front links.
- To raise front of mower, loosen nut "F" from trunnion on both front links. Tighten nut "E" on both front links an equal number of turns.
- When distance "D" is 1/4" to 3/4" lower at front than rear, tighten nut "F" against trunnion on both front links.
- Recheck side-to-side adjustment.

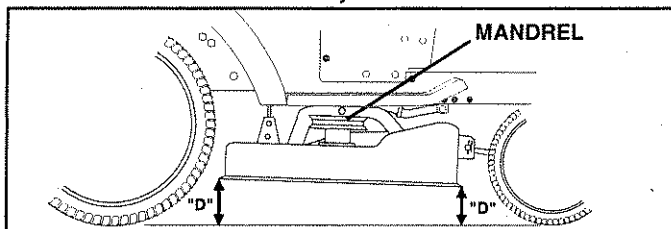

FIG. 19

### BOTH FRONT LINKS MUST BE EQUAL IN LENGTH

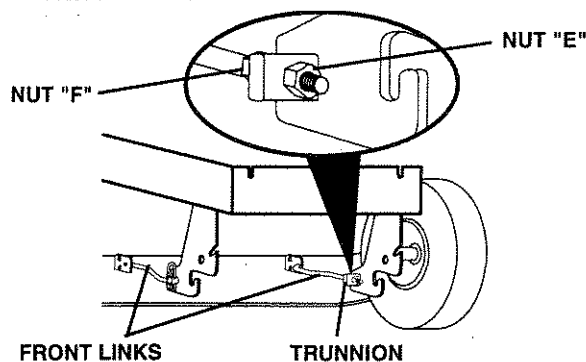
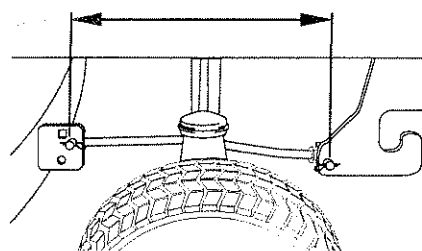

FIG. 20

# SERVICE AND ADJUSTMENTS

## TO REPLACE MOWER BLADE DRIVE BELT (See Fig. 21)

The mower blade drive belt may be replaced without tools. Park the tractor on level surface. Engage parking brake.

### BELT REMOVAL -

- Remove mower from tractor (See "TO REMOVE MOWER" in this section of this manual).
- Work belt off both mandrel pulleys and idler pulleys.
- Pull belt away from mower.

### BELT INSTALLATION -

- Install new belt in reverse order of removal.
- Make sure belt is in all pulley grooves and inside all belt guides.
- Install mower in reverse order of removal instructions.

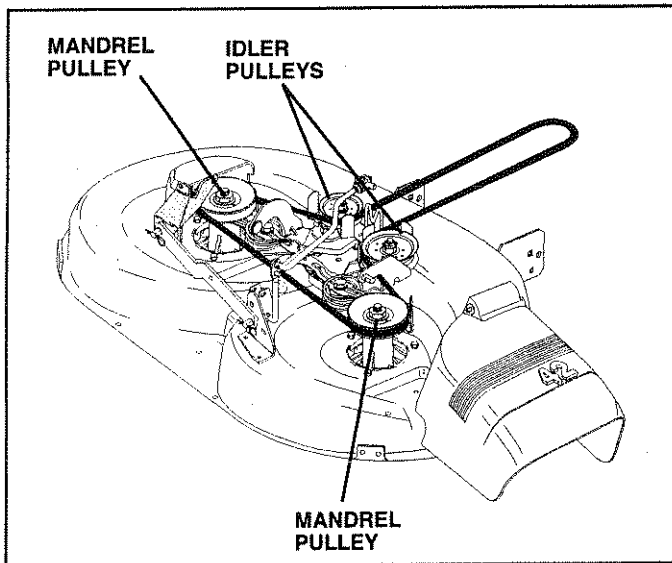

FIG. 21

## TO ADJUST BRAKE (See Fig. 22)

Your tractor is equipped with an adjustable brake system which is mounted on the right side of the transaxle.

If tractor requires more than six (6) feet stopping distance at high speed in highest gear, then brake must be adjusted.

- Depress clutch/brake pedal and engage parking brake.
- Measure distance between brake operating arm and nut "A" on brake rod.
- If distance is other than 1-1/2", loosen jam nut and turn nut "A" until distance becomes 1-1/2". Retighten jam nut against nut "A".
- Road test tractor for proper stopping distance as stated above. Readjust if necessary. If stopping distance is still greater than six (6) feet in highest gear, further maintenance is necessary. Contact your nearest authorized service center/department.

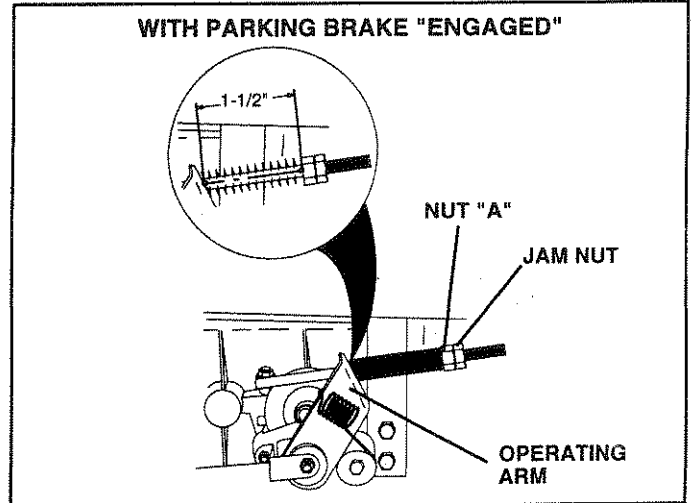

FIG. 22

## TO REPLACE MOTION DRIVE BELT (See Fig. 23)

Park the tractor on level surface. Engage parking brake. For assistance, there is a belt installation guide decal on bottom side of left footrest.

- Remove mower (See "TO REMOVE MOWER" in this section of this manual.)
- Remove upper belt keeper.
- Remove belt from stationary idler and clutching idler.
- Pull belt slack toward rear of tractor. Remove belt upwards from transaxle pulley by deflecting belt keepers.
- Pull belt toward front of tractor and remove downwards from around engine pulley.
- Install new belt by reversing above procedure.

**IMPORTANT:** MAKE SURE UPPER BELT KEEPER IS POSITIONED PROPERLY BETWEEN LOCATOR TABS.

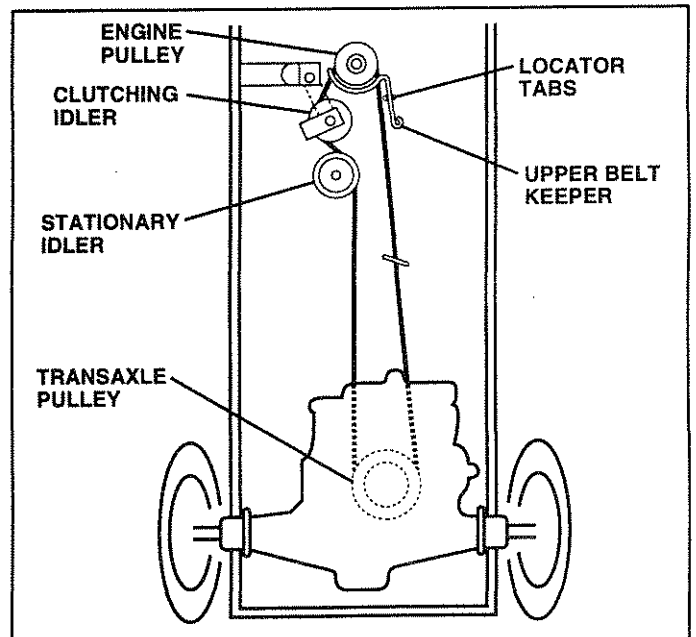

FIG. 23

# SERVICE AND ADJUSTMENTS

## TO ADJUST STEERING WHEEL ALIGNMENT

If steering wheel crossbars are not horizontal (left to right) when wheels are positioned straight forward, remove steering wheel and reassemble per instructions in the Assembly section of this manual.

## FRONT WHEEL TOE-IN/CAMBER

The front wheel toe-in and camber are not adjustable on your tractor. If damage has occurred to affect the front wheel toe-in or camber, contact your nearest authorized service center/department.

## TO REMOVE WHEEL FOR REPAIRS

(See Fig. 24)

- Block up axle securely.
- Remove axle cover, retaining ring and washers to allow wheel removal (rear wheel contains a square key - Do not lose).
- Repair tire and reassemble.
- On rear wheels only: align grooves in rear wheel hub and axle. Insert square key.
- Replace washers and snap retaining ring securely in axle groove.
- Replace axle cover.

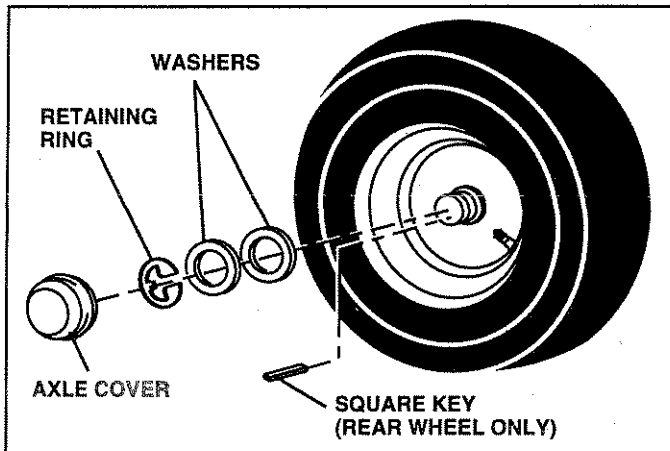

FIG. 24

## TO START ENGINE WITH A WEAK BATTERY (See Fig. 25)



**CAUTION:** Lead-acid batteries generate explosive gases. Keep sparks, flame and smoking materials away from batteries. Always wear eye protection when around batteries.

If your battery is too weak to start the engine, it should be recharged. If "jumper cables" are used for emergency starting, follow this procedure:

**IMPORTANT:** YOUR TRACTOR IS EQUIPPED WITH A 12 VOLT NEGATIVE GROUND SYSTEM. THE OTHER VEHICLE MUST ALSO BE A 12 VOLT NEGATIVE GROUND SYSTEM. DO NOT USE YOUR TRACTOR BATTERY TO START OTHER VEHICLES.

### TO ATTACH JUMPER CABLES -

- Connect each end of the RED cable to the POSITIVE (+) terminal of each battery, taking care not to short against chassis.
- Connect one end of the BLACK cable to the NEGATIVE (-) terminal of fully charged battery.
- Connect the other end of the BLACK cable to good CHASSIS GROUND, away from fuel tank and battery.

### TO REMOVE CABLES, REVERSE ORDER -

- BLACK cable first from chassis and then from the fully charged battery.
- RED cable last from both batteries.

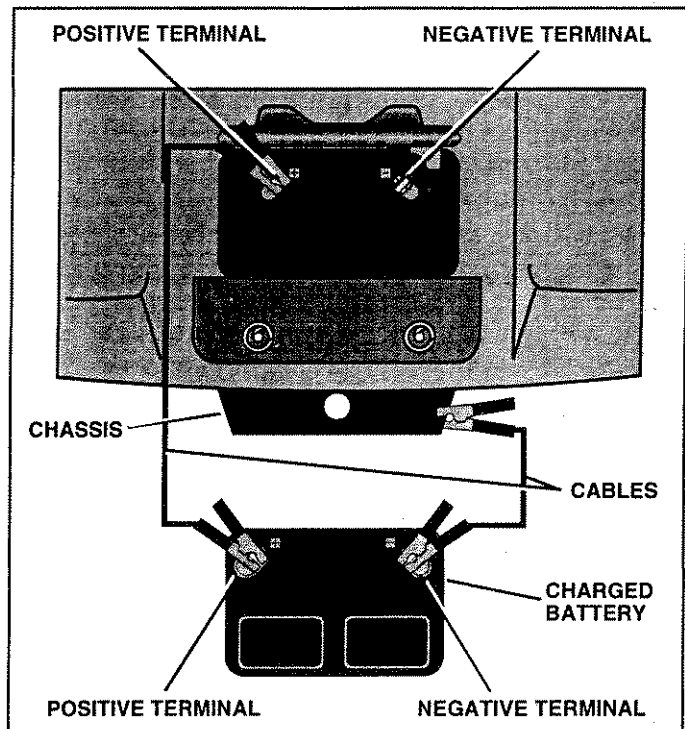

FIG. 25

# SERVICE AND ADJUSTMENTS

## TO REPLACE HEADLIGHT BULB

- Raise hood.
- Pull bulb holder out of the hole in the backside of the grill.
- Replace bulb in holder and push bulb holder securely back into the hole in the backside of the grill.
- Close hood.

## INTERLOCKS AND RELAYS

Loose or damaged wiring may cause your tractor to run poorly, stop running, or prevent it from starting.

- Check wiring. See electrical wiring diagram in the Repair Parts section of this manual.

## TO REPLACE FUSE

Replace with 30 amp automotive-type plug-in fuse. The fuse holder is located behind the dash.

## TO REMOVE HOOD AND GRILL ASSEMBLY (See Fig. 26)

- Raise hood.
- Unsnap headlight wire connector.
- Stand in front of tractor. Grasp hood at sides, tilt toward engine and lift off of tractor.
- To replace, reverse above procedures.

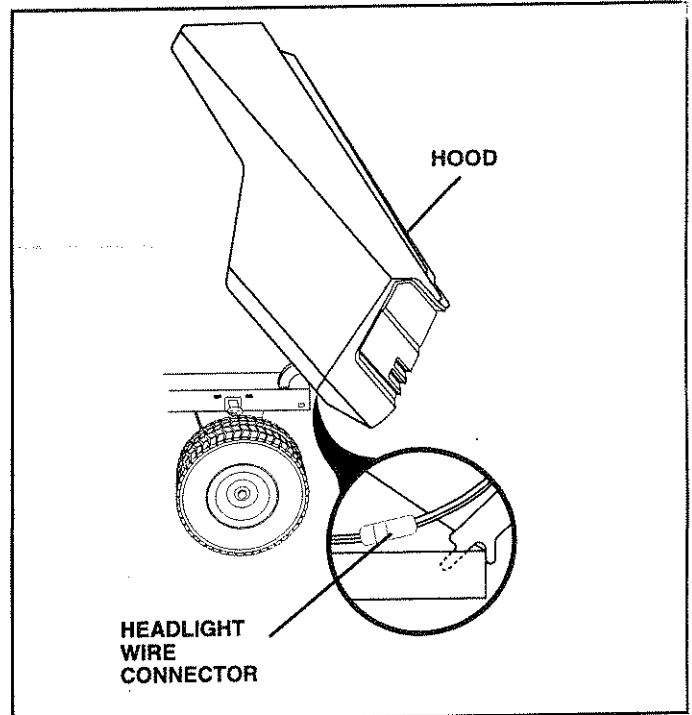

FIG. 26

# SERVICE AND ADJUSTMENTS

## ENGINE

### TO ADJUST THROTTLE CONTROL CABLE (See Fig. 27)

The throttle control has been preset at the factory and adjustment should not be necessary. Check adjustment as described below before loosening cable. If adjustment is necessary, proceed as follows:

- With engine not running, move throttle control lever from slow (S) to choke (N) position. Slowly move lever from choke (N) to fast (F) position.
- Check that holes "A" in governor control lever and hole in governor plate line-up. If holes "A" are not aligned, loosen clamp screw and move throttle cable until holes are aligned. Tighten clamp screw securely.

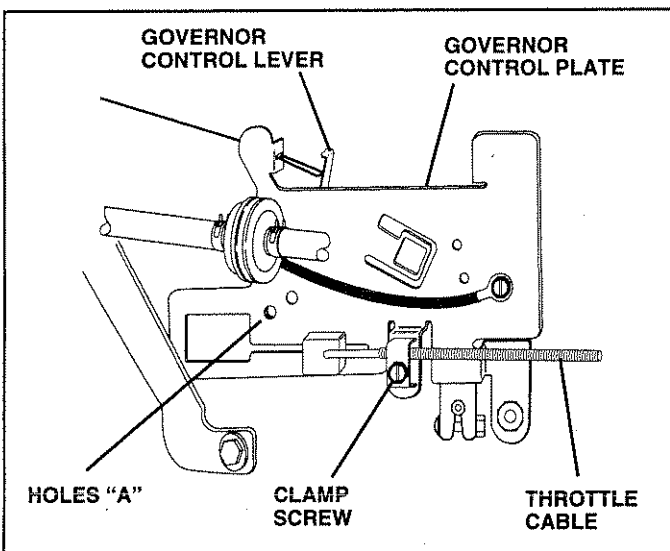

FIG. 27

### TO ADJUST CARBURETOR (See Fig. 28)

**NOTE:** The carburetor on this engine is low emission. It is equipped with an idle fuel adjusting needle with a limiter cap, which allows some adjustment within the limits allowed by the cap. Do not attempt to remove the limiter cap. The limiter cap cannot be removed without breaking the adjusting needle.

The carburetor has been preset at the factory and adjustment should not be necessary. However, minor adjustment may be required to compensate for differences in fuel, temperature, altitude or load. If the carburetor does need adjustment, proceed as follows:

In general, turning idle mixture valve **in** (clockwise) decreases the supply of fuel to the engine giving a leaner fuel/air mixture. Turning the idle mixture valve **out** (counterclockwise) increases the supply of fuel to the engine giving a richer fuel/air mixture.

**IMPORTANT:** DAMAGE TO THE NEEDLE VALVE AND THE SEAT IN CARBURETOR MAY RESULT IF SCREW IS TURNED IN TOO TIGHT.

### PRELIMINARY SETTING -

- Air cleaner assembly must be assembled to the carburetor when making carburetor adjustments.
- Be sure the throttle control cable is adjusted properly (see above).

### FINAL SETTING -

- Start engine and allow to warm for five minutes. Make final adjustments with engine running and shift/motion control lever in neutral (N) position.
- Move throttle control lever to slow (S) position. With finger, rotate and hold throttle lever against idle speed screw. Turn idle speed screw to attain 1750 RPM.
- While still holding throttle lever against idle speed screw, turn idle mixture valve full travel clockwise then counterclockwise until engine runs rough. Turn valve to a point midway between those two positions. Release throttle lever.

### ACCELERATION TEST -

- Move throttle control lever from slow (S) to fast (F) position. If engine hesitates or dies, turn idle mixture valve **out** (counterclockwise) 1/8 turn. Repeat test and continue to adjust, if necessary, until engine accelerates smoothly.

High speed stop is factory adjusted. Do not adjust - damage may result.

**IMPORTANT:** NEVER TAMPER WITH THE ENGINE GOVERNOR, WHICH IS FACTORY SET FOR PROPER ENGINE SPEED. OVERSPEEDING THE ENGINE ABOVE THE FACTORY HIGH SPEED SETTING CAN BE DANGEROUS. IF YOU THINK THE ENGINE-GOVERNED HIGH SPEED NEEDS ADJUSTING, CONTACT YOUR NEAREST AUTHORIZED SERVICE CENTER/DEPARTMENT, WHICH HAS PROPER EQUIPMENT AND EXPERIENCE TO MAKE ANY NECESSARY ADJUSTMENTS.

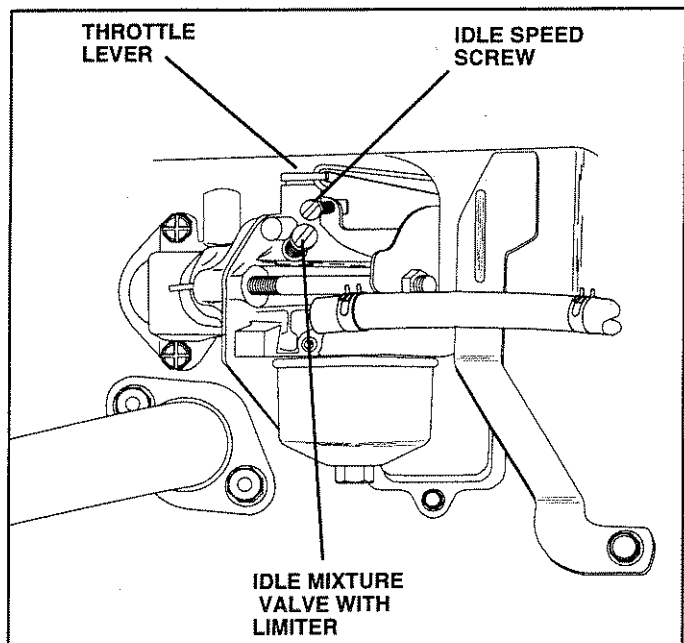

FIG. 28



# STORAGE

Immediately prepare your tractor for storage at the end of the season or if the tractor will not be used for 30 days or more.



**CAUTION:** Never store the tractor with gasoline in the tank inside a building where fumes may reach an open flame or spark. Allow the engine to cool before storing in any enclosure.

## TRACTOR

Remove mower from tractor for winter storage. When mower is to be stored for a period of time, clean it thoroughly, remove all dirt, grease, leaves, etc. Store in a clean, dry area.

- Clean entire tractor (See "CLEANING" in the Customer Responsibilities section of this manual).
- Inspect and replace belts, if necessary (See belt replacement instructions in the Service and Adjustments section of this manual).
- Lubricate as shown in the Customer Responsibilities section of this manual.
- Be sure that all nuts, bolts and screws are securely fastened. Inspect moving parts for damage, breakage and wear. Replace if necessary.
- Touch up all rusted or chipped paint surfaces; sand lightly before painting.

## BATTERY

- Fully charge the battery for storage.
- After a period of time in storage, battery may require recharging.
- To help prevent corrosion and power leakage during long periods of storage, battery cables should be disconnected and battery cleaned thoroughly (see "TO CLEAN BATTERY AND TERMINALS" in the Customer Responsibilities section of this manual).
- After cleaning, leave cables disconnected and place cables where they cannot come in contact with battery terminals.
- Be sure battery drain tube is securely attached.
- If battery is removed from tractor for storage, do not store battery directly on concrete or damp surfaces.

## ENGINE

### FUEL SYSTEM

**IMPORTANT:** IT IS IMPORTANT TO PREVENT GUM DEPOSITS FROM FORMING IN ESSENTIAL FUEL SYSTEM PARTS SUCH AS CARBURETOR, FUEL FILTER, FUEL HOSE, OR TANK DURING STORAGE. ALSO, EXPERIENCE INDICATES THAT ALCOHOL BLENDED FUELS (CALLED GASOHOL OR USING ETHANOL OR METHANOL) CAN ATTRACT MOISTURE WHICH LEADS TO SEPARATION AND FORMATION OF ACIDS DURING STORAGE. ACIDIC GAS CAN DAMAGE THE FUEL SYSTEM OF AN ENGINE WHILE IN STORAGE.

- Drain the fuel tank.
- Start the engine and let it run until the fuel lines and carburetor are empty.
- Never use engine or carburetor cleaner products in the fuel tank or permanent damage may occur.
- Use fresh fuel next season.

**NOTE:** Fuel stabilizer is an acceptable alternative in minimizing the formation of fuel gum deposits during storage. Add stabilizer to gasoline in fuel tank or storage container. Always follow the mix ratio found on stabilizer container. Run engine at least 10 minutes after adding stabilizer to allow the stabilizer to reach the carburetor. Do not drain the gas tank and carburetor if using fuel stabilizer.

### ENGINE OIL

Drain oil (with engine warm) and replace with clean engine oil. (See "ENGINE" in the Customer Responsibilities section of this manual).

### CYLINDERS

- Remove spark plug(s).
- Pour one ounce of oil through spark plug hole(s) into cylinder(s).
- Turn ignition key to "START" position for a few seconds to distribute oil.
- Replace with new spark plug(s).

## OTHER

- Do not store gasoline from one season to another.
- Replace your gasoline can if your can starts to rust. Rust and/or dirt in your gasoline will cause problems.
- If possible, store your tractor indoors and cover it to give protection from dust and dirt.
- Cover your tractor with a suitable protective cover that does not retain moisture. Do not use plastic. Plastic cannot breathe which allows condensation to form and will cause your tractor to rust.

**IMPORTANT:** NEVER COVER TRACTOR WHILE ENGINE AND EXHAUST AREAS ARE STILL WARM.

# TROUBLESHOOTING POINTS

PROBLEM	CAUSE	CORRECTION
<b>Will not start</b>	<ol style="list-style-type: none"> <li>1. Out of fuel.</li> <li>2. Engine not "CHOKED" properly.</li> <li>3. Engine flooded.</li> <li>4. Bad spark plug.</li> <li>5. Dirty air filter.</li> <li>6. Dirty fuel filter.</li> <li>7. Water in fuel.</li>   <li>8. Loose or damaged wiring.</li> <li>9. Carburetor out of adjustment.</li> <li>10. Engine valves out of adjustment.</li> </ol>	<ol style="list-style-type: none"> <li>1. Fill fuel tank.</li> <li>2. See "TO START ENGINE" in Operation section.</li> <li>3. Wait several minutes before attempting to start.</li> <li>4. Replace spark plug.</li> <li>5. Clean/replace air filter.</li> <li>6. Replace fuel filter.</li> <li>7. Drain fuel tank and carburetor, refill tank with fresh gasoline and replace fuel filter.</li> <li>8. Check all wiring.</li> <li>9. Contact an authorized service center/department.</li> <li>10. Contact an authorized service center/department.</li> </ol>
<b>Hard to start</b>	<ol style="list-style-type: none"> <li>1. Dirty air filter.</li> <li>2. Bad spark plug.</li> <li>3. Weak or dead battery.</li> <li>4. Dirty fuel filter.</li> <li>5. Stale or dirty fuel.</li> <li>6. Loose or damaged wiring.</li> <li>7. Carburetor out of adjustment.</li> <li>8. Engine valves out of adjustment.</li> </ol>	<ol style="list-style-type: none"> <li>1. Clean/replace air filter.</li> <li>2. Replace spark plug.</li> <li>3. Recharge or replace battery.</li> <li>4. Replace fuel filter.</li> <li>5. Drain fuel tank and refill with fresh gasoline.</li> <li>6. Check all wiring.</li> <li>7. Contact an authorized service center/department.</li> <li>8. Contact an authorized service center/department.</li> </ol>
<b>Engine will not turn over</b>	<ol style="list-style-type: none"> <li>1. Clutch/brake pedal not depressed.</li> <li>2. Attachment clutch is engaged.</li> <li>3. Weak or dead battery.</li> <li>4. Blown fuse.</li> <li>5. Corroded battery terminals.</li> <li>6. Loose or damaged wiring.</li> <li>7. Faulty ignition switch.</li> <li>8. Faulty solenoid or starter.</li> <li>9. Faulty operator presence switch(es).</li> </ol>	<ol style="list-style-type: none"> <li>1. Depress clutch/brake pedal.</li> <li>2. Disengage attachment clutch.</li> <li>3. Recharge or replace battery.</li> <li>4. Replace fuse.</li> <li>5. Clean battery terminals.</li> <li>6. Check all wiring.</li> <li>7. Check/replace ignition switch.</li> <li>8. Check/replace solenoid or starter.</li> <li>9. Contact an authorized service center/department.</li> </ol>
<b>Engine clicks but will not start</b>	<ol style="list-style-type: none"> <li>1. Weak or dead battery.</li> <li>2. Corroded battery terminals.</li> <li>3. Loose or damaged wiring.</li> <li>4. Faulty solenoid or starter.</li> </ol>	<ol style="list-style-type: none"> <li>1. Recharge or replace battery.</li> <li>2. Clean battery terminals.</li> <li>3. Check all wiring.</li> <li>4. Check/replace solenoid or starter.</li> </ol>
<b>Loss of power</b>	<ol style="list-style-type: none"> <li>1. Cutting too much grass/too fast.</li> <li>2. Throttle in "CHOKE" position.</li> <li>3. Build-up of grass, leaves and trash under mower.</li> <li>4. Dirty air filter.</li> <li>5. Low oil level/dirty oil.</li> <li>6. Faulty spark plug.</li> <li>7. Dirty fuel filter.</li> <li>8. Stale or dirty fuel.</li> <li>9. Water in fuel.</li>   <li>10. Spark plug wire loose.</li> <li>11. Dirty engine air screen/fins.</li> <li>12. Dirty/clogged muffler.</li> <li>13. Loose or damaged wiring.</li> <li>14. Carburetor out of adjustment.</li> <li>15. Engine valves out of adjustment.</li> </ol>	<ol style="list-style-type: none"> <li>1. Set in "Higher Cut" position/reduce speed.</li> <li>2. Adjust throttle control.</li> <li>3. Clean underside of mower housing.</li> <li>4. Clean/replace air filter.</li> <li>5. Check oil level/change oil.</li> <li>6. Clean and regap or change spark plug.</li> <li>7. Replace fuel filter.</li> <li>8. Drain fuel tank and refill with fresh gasoline.</li> <li>9. Drain fuel tank and carburetor, refill tank with fresh gasoline and replace fuel filter.</li> <li>10. Connect and tighten spark plug wire.</li> <li>11. Clean engine air screen/fins.</li> <li>12. Clean/replace muffler.</li> <li>13. Check all wiring.</li> <li>14. Contact an authorized service center/department.</li> <li>15. Contact an authorized service center/department.</li> </ol>
<b>Excessive vibration</b>	<ol style="list-style-type: none"> <li>1. Worn, bent or loose blade.</li> <li>2. Bent blade mandrel.</li> <li>3. Loose/damaged part(s).</li> </ol>	<ol style="list-style-type: none"> <li>1. Replace blade. Tighten blade bolt.</li> <li>2. Replace blade mandrel.</li> <li>3. Tighten loose part(s). Replace damaged parts.</li> </ol>

# TROUBLESHOOTING POINTS

PROBLEM	CAUSE	CORRECTION
Engine continues to run when operator leaves seat with attachment clutch engaged	<ol style="list-style-type: none"> <li>1. Faulty operator-safety presence control system.</li> </ol>	<ol style="list-style-type: none"> <li>1. Check wiring, switches and connections. If not corrected, contact an authorized service center/ department.</li> </ol>
Poor cut - uneven	<ol style="list-style-type: none"> <li>1. Worn, bent or loose blade.</li> <li>2. Mower deck not level.</li> <li>3. Buildup of grass, leaves, and trash under mower.</li> <li>4. Bent blade mandrel.</li> <li>5. Clogged mower deck vent holes from buildup of grass, leaves, and trash around mandrels.</li> </ol>	<ol style="list-style-type: none"> <li>1. Replace blade. Tighten blade bolt.</li> <li>2. Level mower deck.</li> <li>3. Clean underside of mower housing.</li> <li>4. Replace blade mandrel.</li> <li>5. Clean around mandrels to open vent holes.</li> </ol>
Mower blades will not rotate	<ol style="list-style-type: none"> <li>1. Obstruction in clutch mechanism.</li> <li>2. Worn/damaged mower drive belt.</li> <li>3. Frozen idler pulley.</li> <li>4. Frozen blade mandrel.</li> </ol>	<ol style="list-style-type: none"> <li>1. Remove obstruction.</li> <li>2. Replace mower drive belt.</li> <li>3. Replace idler pulley.</li> <li>4. Replace blade mandrel.</li> </ol>
Poor grass discharge	<ol style="list-style-type: none"> <li>1. Engine speed too slow.</li> <li>2. Travel speed too fast.</li> <li>3. Wet grass.</li> <li>4. Mower deck not level.</li> <li>5. Low/uneven tire air pressure.</li> <li>6. Worn, bent or loose blade.</li> <li>7. Buildup of grass, leaves and trash under mower.</li> <li>8. Mower drive belt worn.</li> <li>9. Blades improperly installed.</li> <li>10. Improper blades used.</li> <li>11. Clogged mower deck vent holes from buildup of grass, leaves, and trash around mandrels.</li> </ol>	<ol style="list-style-type: none"> <li>1. Place throttle control in "FAST" position.</li> <li>2. Shift to slower speed.</li> <li>3. Allow grass to dry before mowing.</li> <li>4. Level mower deck.</li> <li>5. Check tires for proper air pressure.</li> <li>6. Replace/sharpen blade. Tighten blade bolt.</li> <li>7. Clean underside of mower housing.</li> <li>8. Replace mower drive belt.</li> <li>9. Reinstall blades sharp edge down.</li> <li>10. Replace with blades listed in this manual.</li> <li>11. Clean around mandrels to open vent holes.</li> </ol>
Headlight(s) not working (if so equipped)	<ol style="list-style-type: none"> <li>1. Switch is "OFF".</li> <li>2. Bulb(s) burned out.</li> <li>3. Faulty light switch.</li> <li>4. Loose or damaged wiring.</li> <li>5. Blown fuse.</li> </ol>	<ol style="list-style-type: none"> <li>1. Turn switch "ON".</li> <li>2. Replace bulb(s).</li> <li>3. Check/replace light switch.</li> <li>4. Check wiring and connections.</li> <li>5. Replace fuse.</li> </ol>
Battery will not charge	<ol style="list-style-type: none"> <li>1. Bad battery cell(s).</li> <li>2. Poor cable connections.</li> <li>3. Faulty regulator (if so equipped).</li> <li>4. Faulty alternator.</li> </ol>	<ol style="list-style-type: none"> <li>1. Replace battery.</li> <li>2. Check/clean all connections.</li> <li>3. Replace regulator.</li> <li>4. Replace alternator.</li> </ol>
Engine "backfires" when turning engine "OFF"	<ol style="list-style-type: none"> <li>1. Engine throttle control not set at "SLOW" position for 30 seconds before stopping engine.</li> </ol>	<ol style="list-style-type: none"> <li>1. Move throttle control to "SLOW" position and allow to idle for 30 seconds before stopping engine.</li> </ol>

---

# SERVICE NOTES

---

# TRACTOR -- MODEL NUMBER 917.256410

## SCHEMATIC

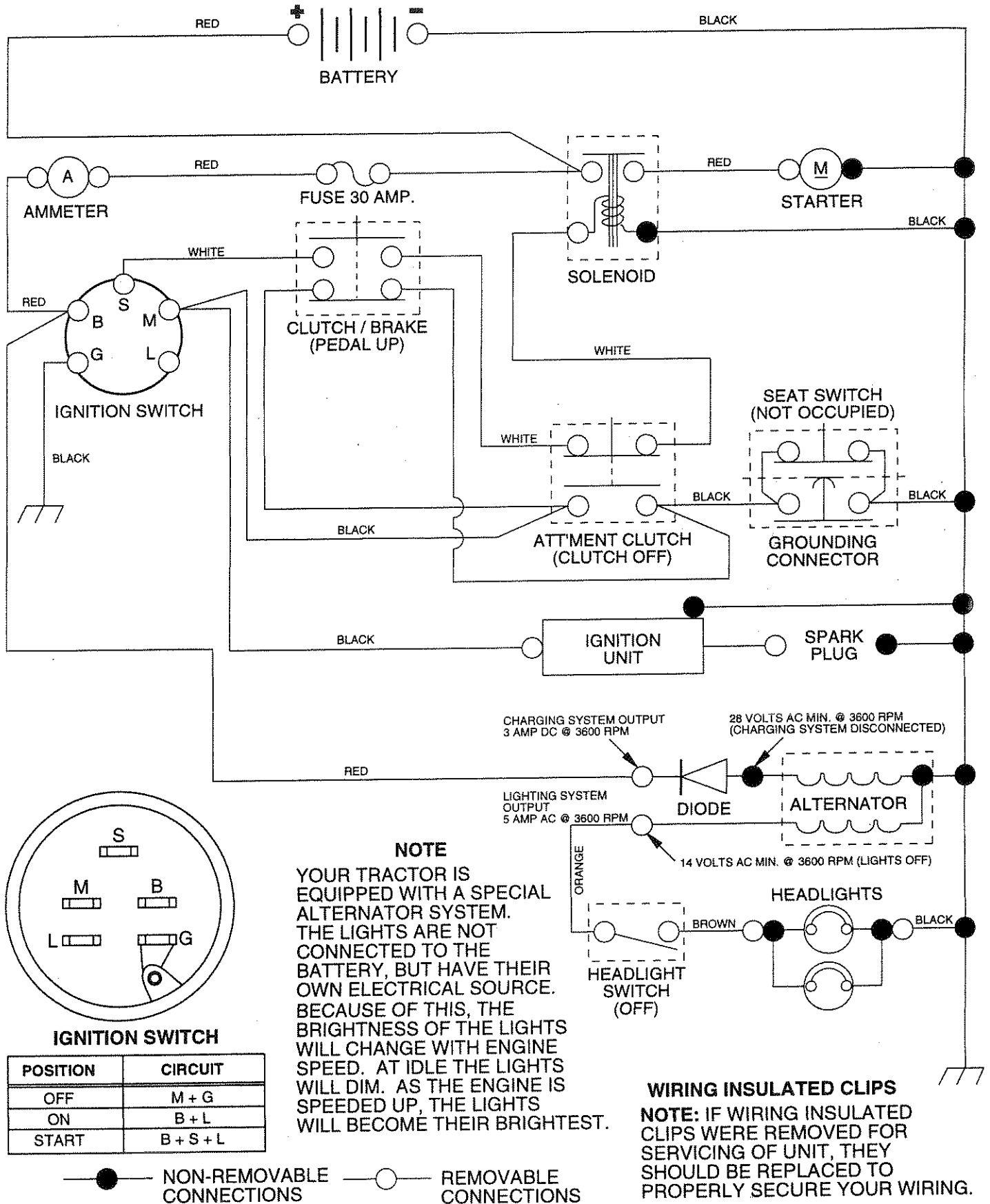

# REPAIR PARTS

TRACTOR -- MODEL NUMBER 917.256410

## ELECTRICAL

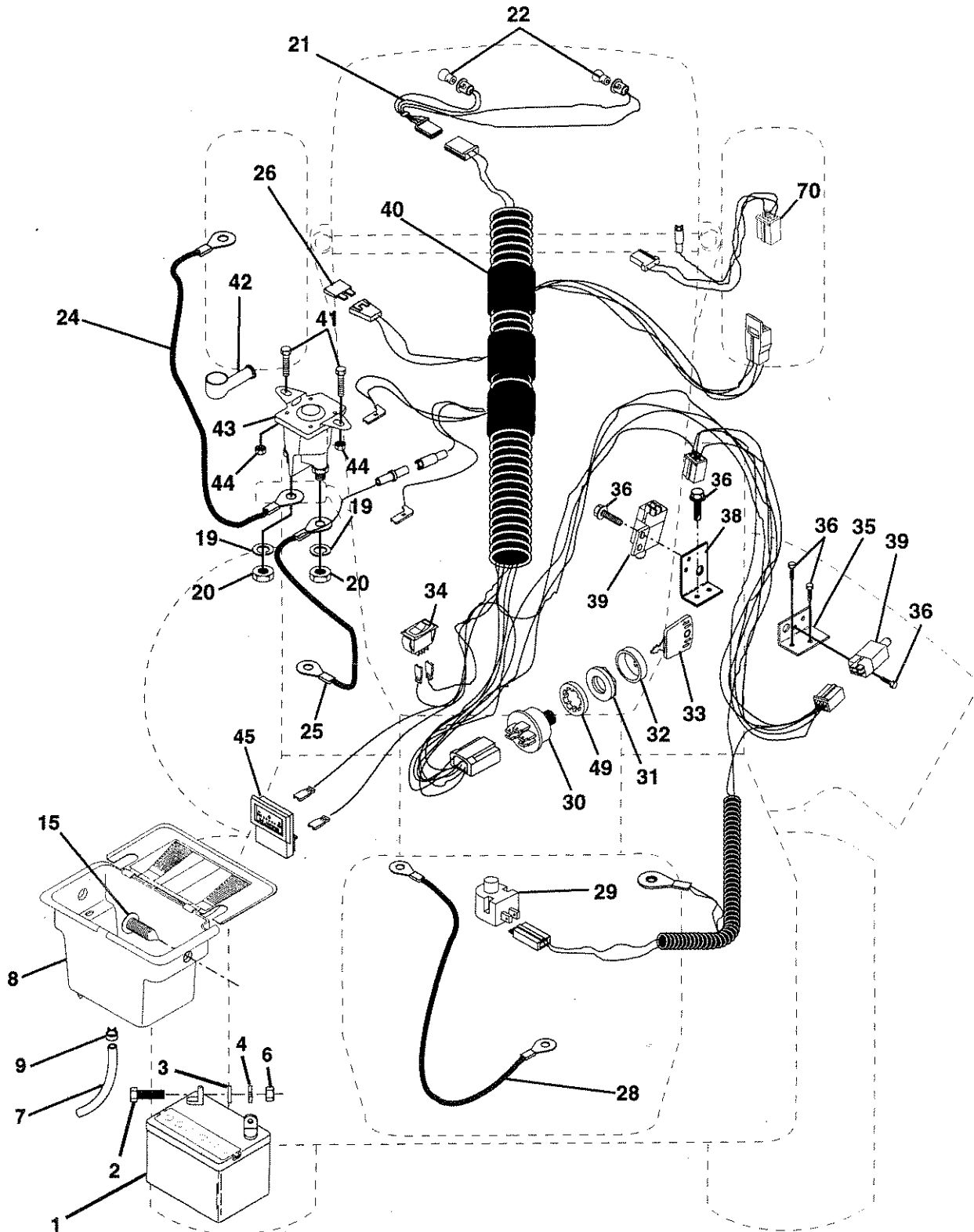

# REPAIR PARTS

TRACTOR - - MODEL NUMBER 917.256410

## ELECTRICAL

KEY NO.	PART NO.	DESCRIPTION
1	146139	Battery 12 Volt 25 AMP
2	STD523107	Bolt Hex Hd 1/4-20unc X 3/4
3	STD551025	Washer 9/32 X 5/8 X 16 Ga
4	STD551125	Washer Lock Hvy Helical 1/4
6	STD541025	Nut Fin Hex 1/4-20 Unc
7	109238X	Tube Plastic 12"
8	144940	Case Battery
9	109596X	Clamp Hose Olive
15	147688	Fastner Snap-In
19	STD551125	Washer Lock 1/4
20	73350400	Nut Jam Hex 1/4-20 Unc
21	136850	Harness Socket Light W/4152J
22	4152J	Bulb Light #1156
24	4799J	Cable Battery 6ga 11" red
25	146147	Cable Battery 6 Ga W/16 Wir red
26	108824X	Fuse 30 AMP Auto Green
28	4207J	Cable Ground 6ga 12" black
29	121305X	Switch Plunger Nc Gray
30	144921	Switch Ign 3 pos
31	140400	Nut Ignition
32	141226	Cover Sw Ignition
33	140403	Key Ign Molded Craftsman, Delta
34	110712X	Switch Light Blk Blk Red
35	108236X	Bracket Switch Clutch
36	STD601005	Screw Tap Hex #10-24unc X 1/2
38	140336	Bracket Switch Interlock
39	109553X	Switch Intlk Cl MWR Gry 4 Term
40	146057	Harness Ign Dash LT 1 PC Mech 95
41	71110408	Bolt Blk Hex 1/4-20unc x 1/2
42	131563	Cover Terminal Red
43	145673	Solenoid
44	73640400	Nut Keps Blk Hex 1/4-20 Unc
45	121433X	Ammeter Rectangular 6 AMP
49	STD551262	Washer Lock Internal Tooth 5/8
70	140413	Harness Engine, B&S/Tec, Dual

**NOTE:** All component dimensions given in U.S. inches  
1 inch = 25.4 mm

# REPAIR PARTS

TRACTOR - - MODEL NUMBER 917.256410

## CHASSIS AND ENCLOSURES

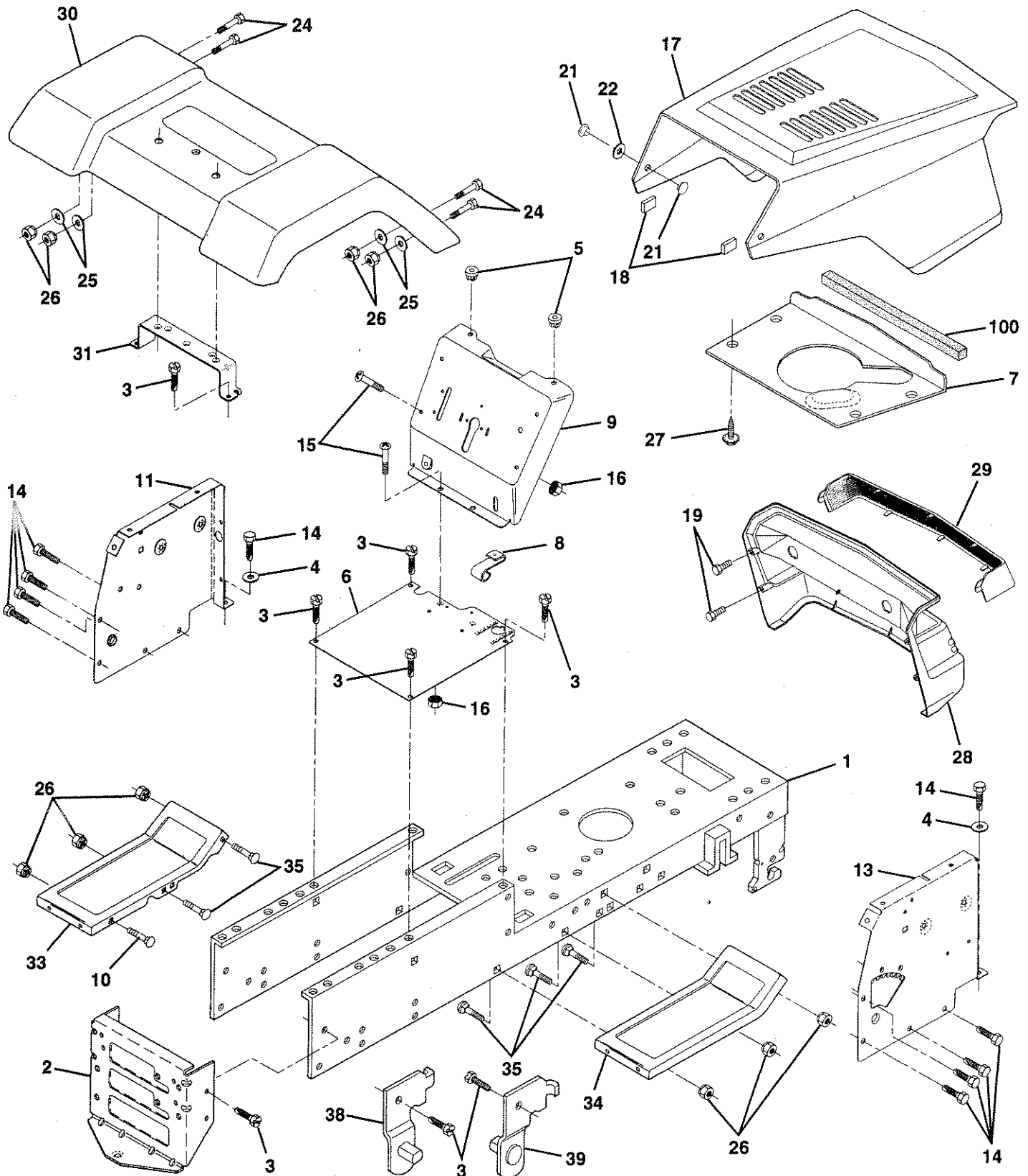



# REPAIR PARTS

TRACTOR - - MODEL NUMBER 917.256410

## CHASSIS AND ENCLOSURES

KEY NO.	PART NO.	DESCRIPTION
1	145501	Chassis Widmt 11ga 1995
2	140356	Drawbar Stretch
3	17490612	Screw Thdrol 3/8-16 x 3/4 Ty-tt
4	STD551025	Washer 13/32 X 3/4 X 16 Ga
5	146077	Bumper Snap-In
6	145208X016	Saddle Slkscr Flt Sdl 65 D4360
7	126842X	Shield Ht. Hood Kohl/Dia Engine
8	126471X	Clip Insulator 406 Mtg Hole
9	146760X011	Dash Slkscr 1-pc
10	STD533710	Bolt Rdhd Sqnk 3/8-16unc X 1
11	146956	Panel Dash LH
13	146961X012	Panel Slkscr Dash RH
14	17490608	Screw Thdrol 3/8-16 x 1/2 Ty-tt
15	74180512	Screw Mach TRHD 5/16-18 unc x 3/4
16	STD541431	Nut Keps 5/16-18 Unc
17	131445X574	Hood Asm Pnt Slope Weld Ms-459
18	126938X	Bumper Hood
19	17030814	Screw Slt'd Hex Hd W/Pl Washer
21	122933X	Rivet Ratchet Nylon
22	124479X	Washer Nylon Blk 28 x 75 x 19
24	STD523710	Bolt Fin Hex 3/8-16 unc x 1 Gr. 5
25	19131312	Washer 13/32 X 13/16 x 12 Ga
26	STD541437	Nut Hex Lock W/Ins. 3/8-16 Unc
27	17030814	Screw Spiderloc Hex Hd #8 x 7/8
28	140137	Grille Grey
29	124029X	Lens Headlight Bar Clear
30	109872X574	Fender Pnt LT W/o Shift
31	136619	Bracket Fender Repl 109873x
33	145244X574	Footrest Pnt Lh
34	145243X574	Footrest Pnt Rh
35	STD533707	Bolt Rdhd Sht Sqnk 3/8-16 x 3/4
38	139886	Bracket Asm Pvt LH MWR Rear
39	139887	Bracket Asm Pvt RH MWR Rear
100	105037X	Strip Foam 18"
--	5479J	Plug Button Blk 359 Dia Choke

**NOTE:** All component dimensions given in U.S. inches  
1 inch = 25.4 mm

# REPAIR PARTS

TRACTOR - - MODEL NUMBER 917.256410

## DRIVE

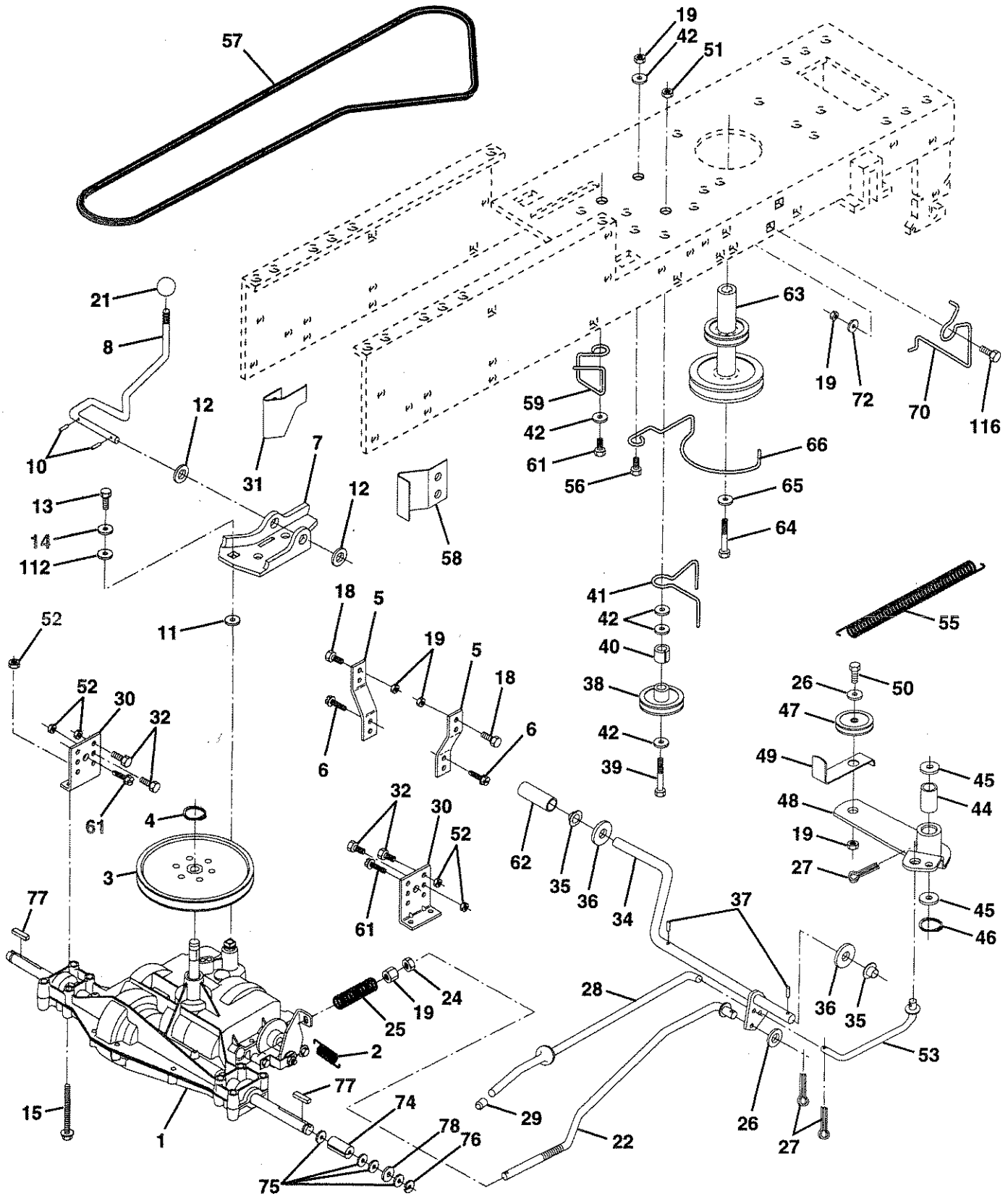

# REPAIR PARTS

## TRACTOR -- MODEL NUMBER 917.256410

### DRIVE

KEY NO.	PART NO.	DESCRIPTION	KEY NO.	PART NO.	DESCRIPTION
1	142603	Transaxle 6sp Std D4360-79	41	109070X	Keeper Belt Retainer
2	146682	Spring Return Brake T/a Zinc	42	19131312	Washer 13/32 X 13/16 X 12 Ga
3	123666X	Pulley Transaxle 18/20" tires	44	105706X	Bearing Nyl 503 X 628 X 1 25
4	12000028	Ring Retainer # 5100-62	45	110812X	Washer Hardened
5	121520X	Strap Torque 30 Degrees	46	12000039	Ring Klip #t5304-50
6	17490512	Screw Thdrol 5/16-18 X 3/4 TYT	47	127783	Pulley Idler V Groove Plastic
7	130802	Bracket Saddle Shift T/a	48	123789X	Bellcrank Asm Clutch
8	131679	Rod Shf Sdl LY/YT Str Blk Zinc	49	123205X	Retainer Belt Style Spring
10	STD561210	Pin Cotter 1/8 X 1 Cad	50	STD523715	Bolt Hex Hd 3/8-16unc X 1-1/2
11	105701X	Washer Plate Shf 388 Sq Hole	51	STD541437	Nut Crownlock 3/8-16 UNC
12	19151216	Washer 15/32 X 3/4 X 16ga	52	STD541431	Nut Crown Lock 5/16-18
13	74550412	Bolt 1/4-28unf Gr8 W/Patch	53	105710X	Link Clutch 7 66
14	STD551125	Washer Lock Hvy Helical 1/4	55	105709X	Spring Return Clutch 6 75
15	74490544	Bolt Hex FLGHD5/16-18Gr.5	56	STD523712	Bolt Fin Hex 3/8-16 unc x 1-1/4
18	STD523710	Bolt Fin Hex 3/8-16unc X 1 Gr. 5	57	130801	V-Belt Gd Drive 95 25
19	STD541437	Nut Lock Hex W/Ins. 3/8-16 Unc	58	127274X	Keeper Belt RH LT Pnt/zinc 16g
21	106933X	Knob Rd 1/2-13 Plstc Thds Blk	59	140312	Keeper Belt Centerspan
22	130804	Rod Brake Blk Zinc 26 840	61	17490612	Screw Thdrol 3/8-16x3/4 Ty-tt
24	STD541237	Nut Hex Jam 3/8-16 Unc	62	8883R	Cover Pedal Blk Round
25	106888X	Spring Rod Brake 2 00 Zinc	63	140186	Pulley Eng Cl Mech 38deg LT/YT
26	STD551037	Washer 13/32 X 13/16 X 16 Ga	64	71170764	Bolt Hex 7/16-20x4 Gr 5
27	STD561210	Pin Cotter 1/8 X 3/4 Cad	65	STD551143	Washer Lock Hvy Hlcl Spr 7/16
28	145204	Rod Brake Parking Lt/Yt	66	129921	Keeper Belt Engine LH LT
29	124236X	Cap Brake Parking Red	70	134683	Guide Belt Mower Drive RH
30	130807	Bracket Mtg Transaxle	72	19132012	Washer 13/32 X 1-1/4 X 12 Ga
31	127275X	Keeper Belt LH LT 14 Ga	74	109502X	Spacer Split 80x1 94 Cad/zinc
32	STD523107	Bolt Hex Hd 5/16-18unc X 3/4	75	121749X	Washer 25/32 X 1 1/4 X 16 Ga
34	149001	Shaft Asm Pedal Foot	76	STD581075	E-ring #5133-75
35	120183X	Bearing Nylon Blk 629 Id	77	123583X	Key Square 2 0 X 1845/ 1865
36	STD551062	Washer 21/32 X 1 X 16 Ga	78	121748X	Washer 25/32 X 1-5/8 X 16ga
37	1572H	Pin Roll 3/16 X 1"	112	19091210	Washer 9/32 X 3/4 X 10 Ga
38	123674X	Pulley Idler Flat			
39	STD523727	Bolt Fin Hex 3/8-16unc X 2-3/4			
40	4470J	Spacer Split 395 X 59 Bzp			

**NOTE:** All component dimensions given in U.S. inches.  
1 inch = 25.4 mm

# REPAIR PARTS

TRACTOR -- MODEL NUMBER 917.256410

## STEERING ASSEMBLY

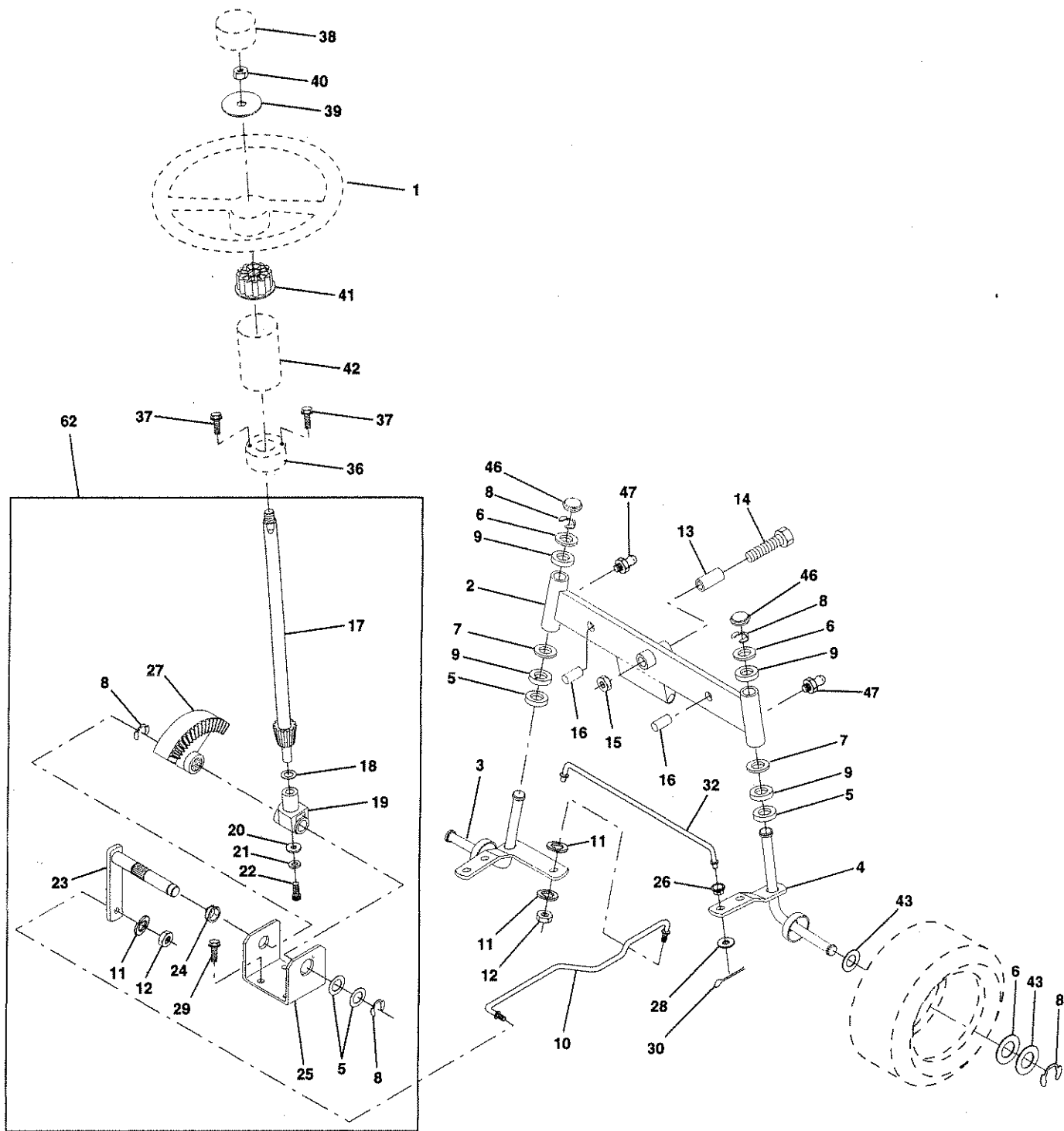

# REPAIR PARTS

## TRACTOR - - MODEL NUMBER 917.256410

### STEERING ASSEMBLY

KEY NO.	PART NO.	DESCRIPTION
1	139768	Wheel Steering Opp Sears Blk
2	142033	Axle Asm Front Lt
3	135227	Spindle Asm Lh
4	135228	Spindle Asm Rh
5	6266H	Washer Thrust .75 x 1.230
6	121748X	Washer 25/32 x 1-5/8 x 16 Ga.
7	19272016	Washer 27/32 x 1-1/4 x 16 Ga.
8	12000029	RingKlip #T5304-75
9	3366R	Bearing Col Strg Blk
10	130468	Link Drag Sol Ball Jt 20.064
11	STD551137	Washer Lock Hvy Hlcl Spr 3/8
12	73610600	Nut Fin Hex 3/8-24 Unf
13	110438X	Spacer Bearing Axle Front
14	74011056	Bolt, Hex 5/8-11 UNC x 3-1/2
15	73901000	Locknut Flange 5/8-11 UNC
16	132624	Pin Axle 5/8 x 1.55/1.54 Lg
17	132614	Shaft Asm Strg 5/8 x 15.19 Lt
18	57079	Washer Thrust .515 x .750 x .033
19	124035X	Support Shaft
20	126684X	Washer Shim 1/4 x 5/8 x .062
21	STD551125	Washer Lock Hvy Helical 1/4
22	71100410	Screw Cap Socket HD
23	127501	Shaft Asm Pitman
24	109816X	Nyliner Snap In
25	124036X	Bracket Steering
26	126847X	Bushing Link Drag Blk LR
27	136874	Gear Sector 22 Teeth
28	19131416	Washer 13/32 x 7/8 x 16 Ga.
29	17490612	Screw Thdrol 3/8-16 x 3/4 TY-TT
30	STD561210	Pin Cotter 1/8 x 3/4 Cad
32	130465	Rod Tie Wire Form 19.75 Mech
36	132196	Bushing Strg. 5/8 ID Dash
37	17431008	Screw Slftp #10-16 x 1/2 Ty-B
38	139769	Cap Wheel Steer Opp Sears Blk
39	19133808	Washer 13/32 x 2-3/8 x 8 Ga.
40	STD541537	Locknut Center 3/8-24 Unf
41	104820X	Adaptor Wheel Strg. .640/.635 Id
42	124417X	Boot Shaft Steering Craftsman
43	121749X	Washer 25/32 x 1-1/4 x 16 Ga.
46	121232X	Cap Spindle Fr Top Blk
47	6855M	Fitting Grease
62	149684	Steering Assembly

**NOTE:** All component dimensions given in U.S. inches  
1 inch = 25.4 mm

# REPAIR PARTS

TRACTOR -- MODEL NUMBER 917.256410

## ENGINE

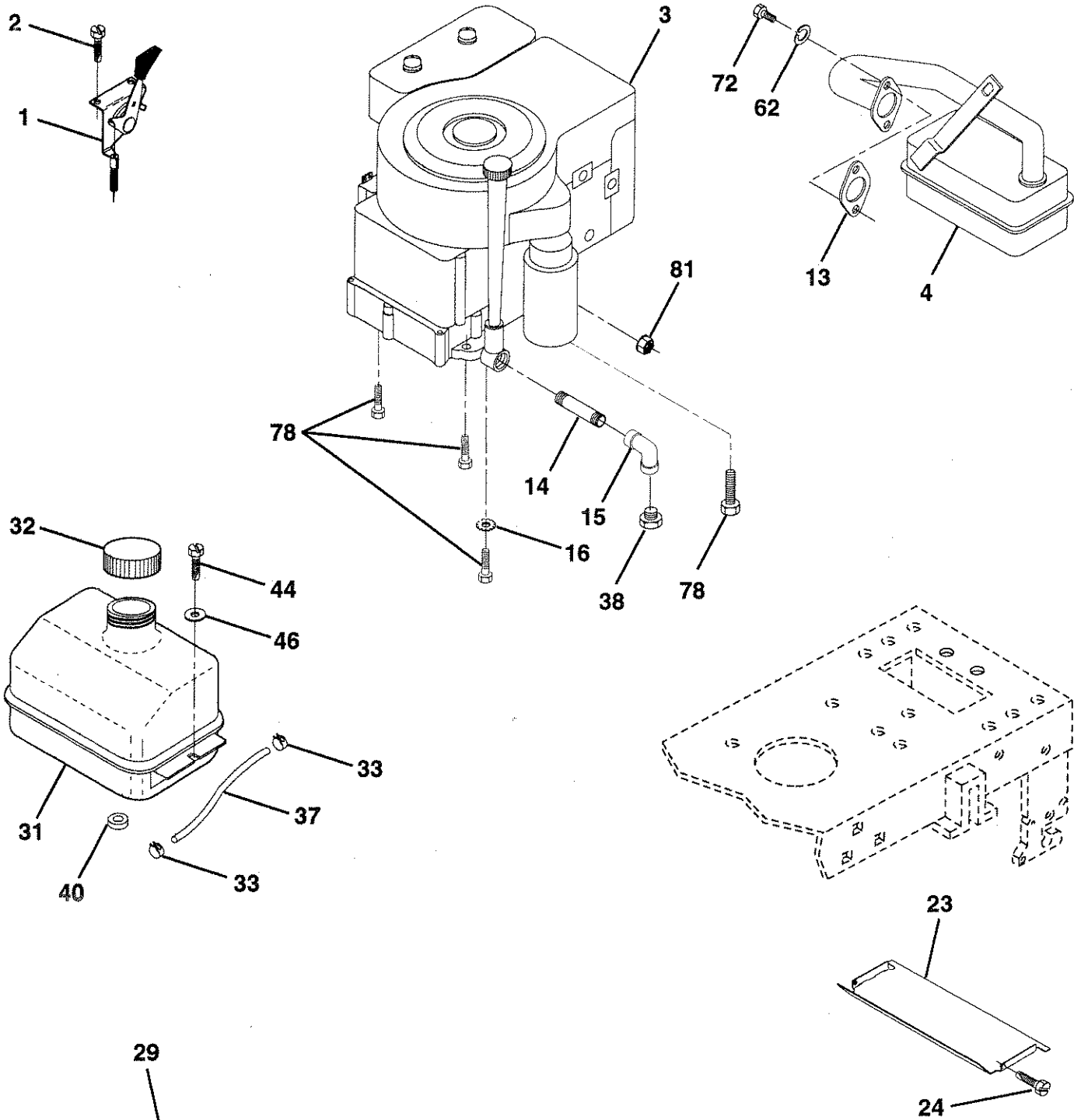

**OPTIONAL EQUIPMENT**  
**Spark Arrester**

# REPAIR PARTS

## TRACTOR - - MODEL NUMBER 917.256410

### ENGINE

KEY NO.	PART NO.	DESCRIPTION
1	132759	Control Th/ch RH Blk Pdl 15 10
2	17720410	Screw Hex Thd Cut 1/4-20x5/8 T
3	152512	Engine B&S 13.5HP IC/GOLD Model No 28R707, Type No.0140-01 — <i>Type 0437-A1</i>
4	137348	Muffler LT B&S 12/12 5/13 HP
13	272293	Gasket Eng 1 313 Id Tin Plated
14	13280324	Nipple Pipe 3/8 Npt x 3"
15	13200300	Elbow Std 90 Degree 3/8-18 Npt
16	STD551237	Washer Lock Ext Tooth 3/8
23	128953	Shield Heat Browning LT/YT
24	17021008	Screw Tap Hex #10-24 unc X 1/2
29	137180	Kit Spark Arrestor (Flat Scrn)
31	109202X	Tank Fuel Front 1 25
32	123549X	Cap Asm Fuel W/sym Vented
33	123487X	Clamp Hose Blk
37	137040	Line Fuel 20"
38	-----	Plug Oil Drain (Order From Engine Manufacturer)
40	124028X	Bushing Snap Nyl Blk Fuel Line
44	17490412	Screw Hexwsh Thdrol 1/4-20 x 3/4
46	19091416	Washer 9/32 x 7/8 x 16 ga
62	STD551131	Washer Lock Hvy Hlcl Spr 5/16
72	71070512	Screw Hex Hd Cap 5/16-18 X 3/4
78	17490620	Screw Thdrol 3/8-16x1-1/4 TYTT
81	128861	Nut Flange 1/4-20 Starter Nut

**NOTE:** All component dimensions given in U.S. inches  
1 inch = 25.4 mm

# REPAIR PARTS

## TRACTOR - - MODEL NUMBER 917.256410

### SEAT ASSEMBLY

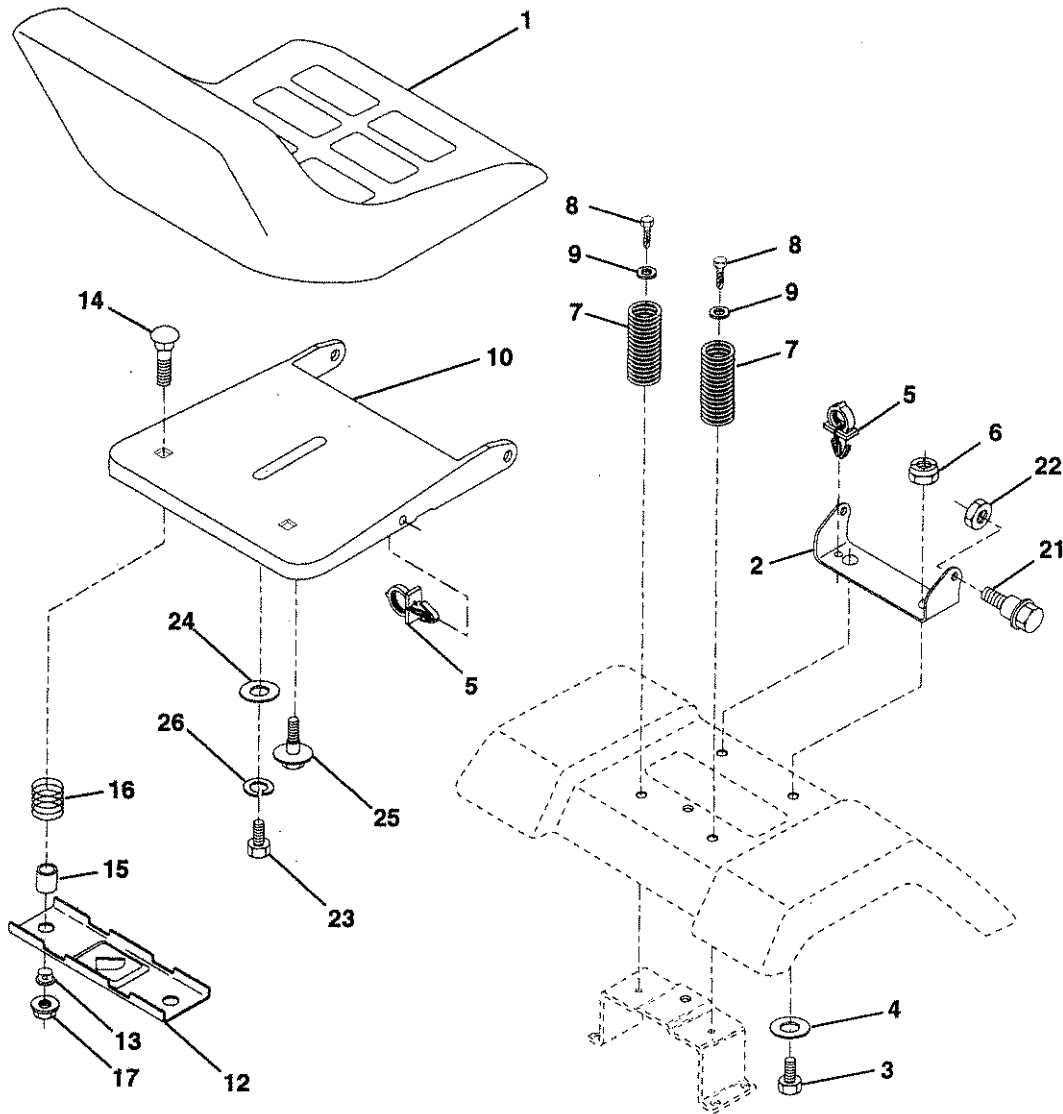

KEY NO.	PART NO.	DESCRIPTION
1	140122	Seat
2	140551	Bracket Pvt St
3	STD523710	Bolt Fin Hex 3/8-16unc X 1
4	19131610	Washer Flat 13/32 X 1 X 10 Ga
5	145006	Clip Push-In Hinged
6	STD541437	Locknut Hex W/Wsh 3/8-16
7	124181X	Spring Seat Cprsn 2 250 Blk Zi
8	17490616	Screw Thdrol 3/8-16 X 1 Ty-tt
9	19131614	Washer 13/32 X 1 X 14 Ga
10	140552	Pan Seat
12	121246X	Bracket Mounting Switch
13	121248X	Bushing Snap Blk Nyl 50 Id

KEY NO.	PART NO.	DESCRIPTION
14	72050411	Bolt Rdhd Sht Nk 1/4-20x1-3/8
15	134300	Spacer Split 28x 96 Yel Zinc
16	121250X	Spring Cprsn 1 27 Blk Pnt
17	123976X	Nut Lock 1/4 Lge Flg Gr 5 Zinc
21	139888	Bolt Shld 5/16-18 Type Tt T R
22	STD541431	Nut Lock Hex "W/Ins 5/16-18
23	74780814	Bolt Fin Hex 1/2-13 X 7/8 Gr 5
24	19171912	Washer 17/32 X 1-3/16 X 12 Ga
25	127018X	Bolt Shoulder 5/16-18 X 62
26	STD551150	Washer Lock Hvy Hlcl Spr 1/2

**NOTE:** All component dimensions given in U.S. inches  
1 inch = 25.4 mm



# REPAIR PARTS

TRACTOR -- MODEL NUMBER 917.256410

## DECALS

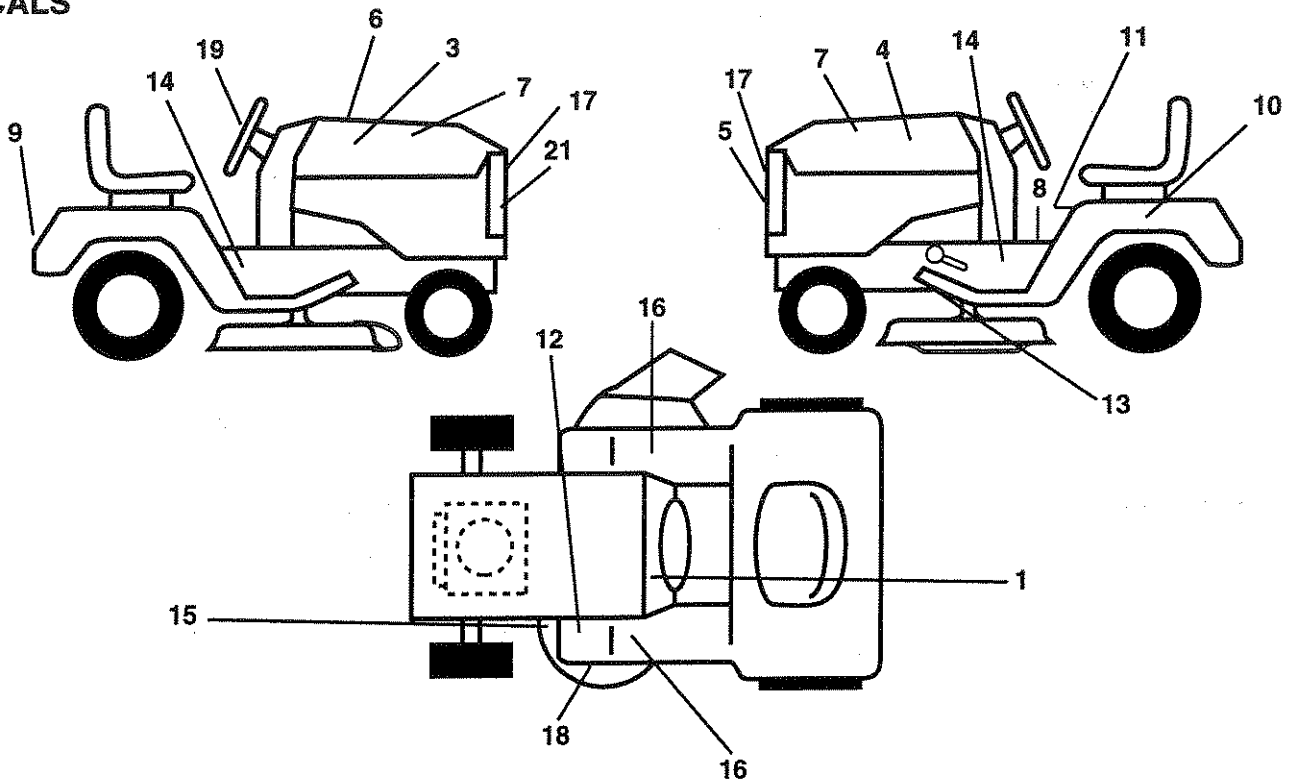

KEY NO.	PART NO.	DESCRIPTION	KEY NO.	PART NO.	DESCRIPTION
1	138955	Decal Dash Inst Oper English	13	146046	Decal V-Belt Dr Sch Tractor
3	150676	Decal Hood RH Crafts Slp LT	14	150678	Decal Chassis 6sp 42"
4	150677	Decal Hood LH Crafts Slp LT	15	136832	Decal V-Belt Sch
5	150680	Decal Grille Crafts	16	145245	Pad Footrest
6	133644	Decal Maint Cust Sears Domesti	17	150679	Decal Ins Hood
7	142235	Decal Side Pnl lcgold Blk B & S	18	133179	Decal Mower Qc System
8	140837	Decal Brake Parking Saddle	19	150333	Decal Cap CNSMR Help Line SRS
9	128314	Decal Fender Craftsman Red	21	131265	Decal Lightbox
10	149516	Decal Battery Dngr/Psn Eng Acme	--	145247	Fastner Pop-in
11	137537	Decal Caution Fender Eng/span	--	138311	Decal Handle Lft Height Adjust
12	4900J	Decal Clutch/brake English	--	152829	Manual Owners English
			--	152830	Manual Owners Spanish

## WHEELS & TIRES

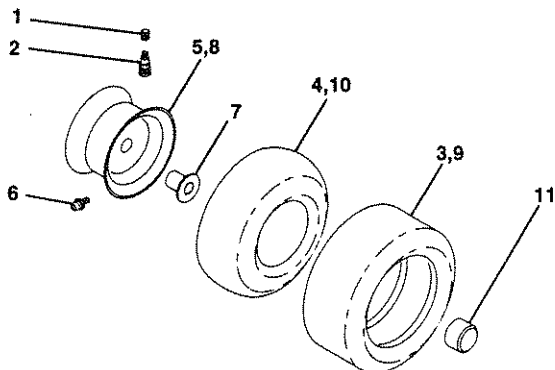

KEY NO.	PART NO.	DESCRIPTION
1	59192	Cap Valve Tire
2	65139	Stem Valve
3	106222X	Tire F Ts 15 X 6 0 - 6 Service
4	59904	Tube Front (Service Item Only)
5	106732X427	Rim Asm 6" f ront White Service
6	278H	Fitting Grease (Front Wheel Only)
7	9040H	Bearing Flange (Front Wheel Only)
8	106108X427	Rim Asm 8" rear White Service
9	124635X	Tire R Ts 18x8 5-8 C Service
10	7152J	Tube Rear (Service Item Only)
11	104757X	Cap Hub Axle Blk 1 50 X 1 00
--	144334	Sealant, Tire (10 oz. Tube)

**NOTE:** All component dimensions given in U.S. inches  
1 inch = 25.4 mm

# REPAIR PARTS

TRACTOR - - MODEL NUMBER 917.256410

LIFT

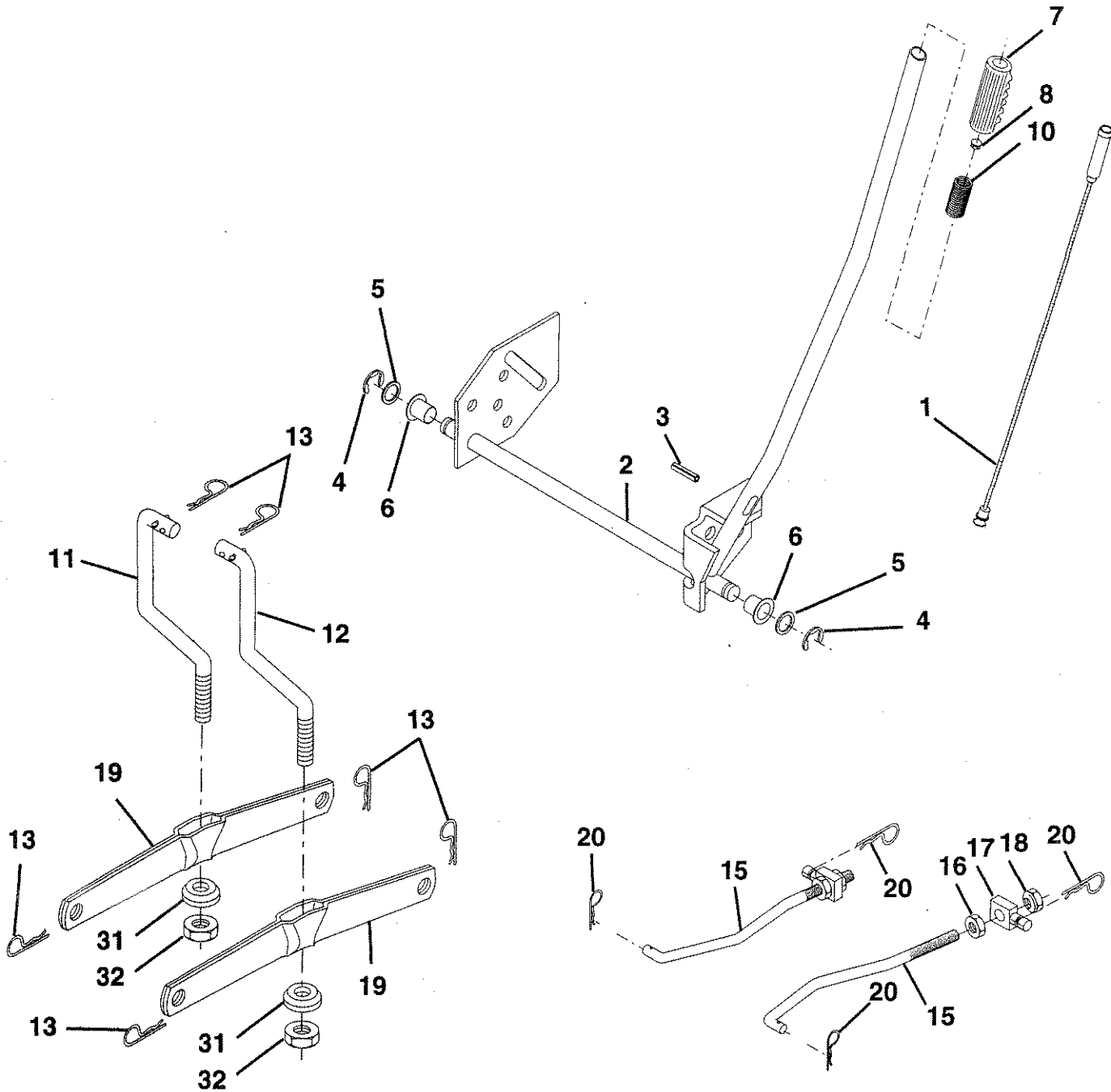

# REPAIR PARTS

TRACTOR - - MODEL NUMBER 917.256410

## LIFT

KEY NO.	PART NO.	DESCRIPTION
1	136973	Wire Asm Inner W/plunger 17 32
2	122507X	Shaft Asm Lift 9 680
3	105767X	Pin Groove 1 500 Zinc
4	12000002	E Ring #5133-62
5	19211621	Washer Pltd 21/32 X 1 X 21ga
6	120183X	Bearing Nylon Blk 629 Id
7	125631X	Grip Handle Fluted Blk
8	122365X	Button Plunger Red
10	122512X	Spring Cprsn 3 750 Oiled
11	139865	Link Lift LH
12	139866	Link Lift RH
13	STD624008	Retainer Spring
15	127218	Link Front
16	73350800	Nut Jam Hex 1/2-13 Unc
17	130171	Trunnion Blk Zinc
18	73800800	Nut Lock W/wsh 1/2-13unc
19	139868	Arm Suspension Rear
20	STD624008	Retainer Spring Zinc
31	140302	Bearing Pvt Lift Spherical
32	73540600	Nut Crownlock 3/8-24

**NOTE:** All component dimensions given in U.S. inches  
1 inch = 25.4 mm

# REPAIR PARTS

TRACTOR - - MODEL NUMBER 917.256410

MOWER

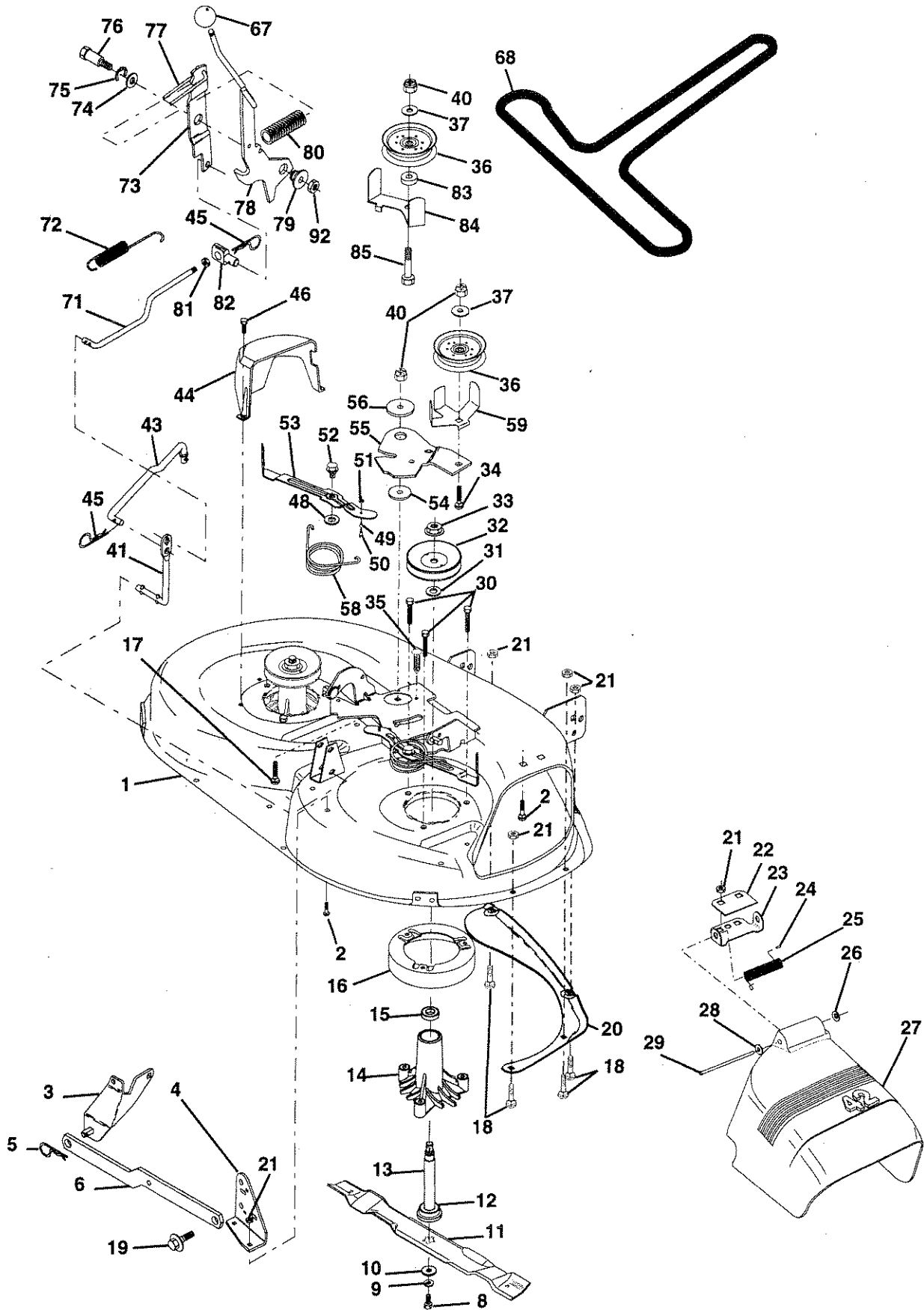

# REPAIR PARTS

## TRACTOR - - MODEL NUMBER 917.256410

### 42" MOWER

KEY NO.	PART NO.	DESCRIPTION	KEY NO.	PART NO.	DESCRIPTION
1	144393	Mower Housing	44	140088	Guard, Mandrel, L.H.
2	STD533107	Bolt	45	STD624003	Retainer
3	138017	Bracket Assembly, Sway Bar, Front	46	137729	Screw, Thd. Roll 1/4-20 x 5/8
4	138440	Bracket Assembly, Sway Bar	48	133944	Washer, Hardened
5	STD624008	Retainer Spring	49	133940	Roller Assembly, Cam Follower
6	130832	Arm, Suspension, Rear	50	131340	Bolt, Shoulder #10-24 Grade 5
8	850857	Bolt, Hex 3/8-24 x 1.25 Grade 8	51	STD541410	Locknut
9	STD551137	Washer, Lock	52	139888	Bolt, Shoulder 5/16-18 UNC
10	140296	Washer, Hardened	53	131845	Arm Assembly, Pad, Brake
11	134149	Blade, Mulching	54	133943	Washer, Hardened
12	129895	Bearing, Ball	55	140084	Arm, Idler
13	137645	Shaft Assembly, Mandrel, Vented (Includes Key Number 6)	56	122052X	Spacer, Retainer
14	128774	Housing, Mandrel, Vented	58	140086	Spring, Torsion Brakes 42"
15	110485X	Bearing, Ball, Mandrel	59	141043	Guard, Tuv Idler (94)
16	140329	Stripper, Vented Mower Deck	67	149846	Knob, Custom Oval
17	72110610	Bolt, Carriage 3/8-16 x 2-1/4	68	144200	V-Belt
18	72140505	Bolt, Carriage 5/16-18 x 5/8	71	142427	Rod, Clutch, Primary, with Nibs
19	132827	Bolt, Shoulder	72	131870	Spring, Return
20	136888	Baffle, Vortex	73	127847	Arm, Clutch, Secondary
21	STD541431	Nut, Crownlock 5/16-18 UNC	74	121748X	Washer 25/32 x 1-5/8 x 16 Gauge
22	134753	Stiffener Bracket	75	1200029	Ring, Klip
23	131267	Bracket, Deflector	76	128903	Bolt, Shoulder 3/8-16 UNC x 1.44
24	105304X	Cap, Sleeve	77	127845	Keeper, Spring
25	123713X	Spring, Torsion, Deflector	78	140334	Arm, Clutch, Primary
26	110452X	Nut, Push	79	127498	Bushing, Large, Brass
27	130968	Shield, Deflector	80	128759	Spring, Mower Clutch
28	19111016	Washer 11/32 x 5/8 x 16 Gauge	81	73350600	Nut, Hex Jam 3/8-16 UNC
29	131491	Rod, Hinge	82	142028	Trunion Adj. 94
30	138776	Screw Thdrol Hex Head Zinc Mwr	83	120958X	Washer Sintered
31	129963	Washer, Spacer	84	144394	Keeper Belt Idler Fixed
32	129861	Pulley, Mandrel	85	72140618	Bolt Carriage 3/8-16 x 2-1/4
33	137266	Nut, Toplock, Flanged	92	STD541437	Locknut, Hex W/Wsh 3/8-16 UNC
34	STD533717	Bolt	--	130794	Mandrel Assembly (Includes Key Numbers 8-10, 12-15, 31 and 32)
35	133835	Fastner, Christmas Tree	--	145411	Mower Deck, Complete
36	131494	Pulley, Idler, Flat	Available Mulcher Plate Kit not included with tractor:		
37	STD551037	Washer 13/32 x 13/16 x 16 Ga.	--	141112	Mulcher Close-out Plate Kit
40	STD541437	Nut, Crownlock 3/8-16 UNC			
41	133551	Rod, Pivot, with Nibs			
43	140083	Rod, Clutch, Secondary, with Nibs			

**NOTE:** All component dimensions given in U.S. inches  
1 inch = 25.4 mm.

# REPAIR PARTS

TRACTOR -- MODEL NUMBER 917.256410

DANA TRANSAXLE - MODEL NUMBER 4360-79

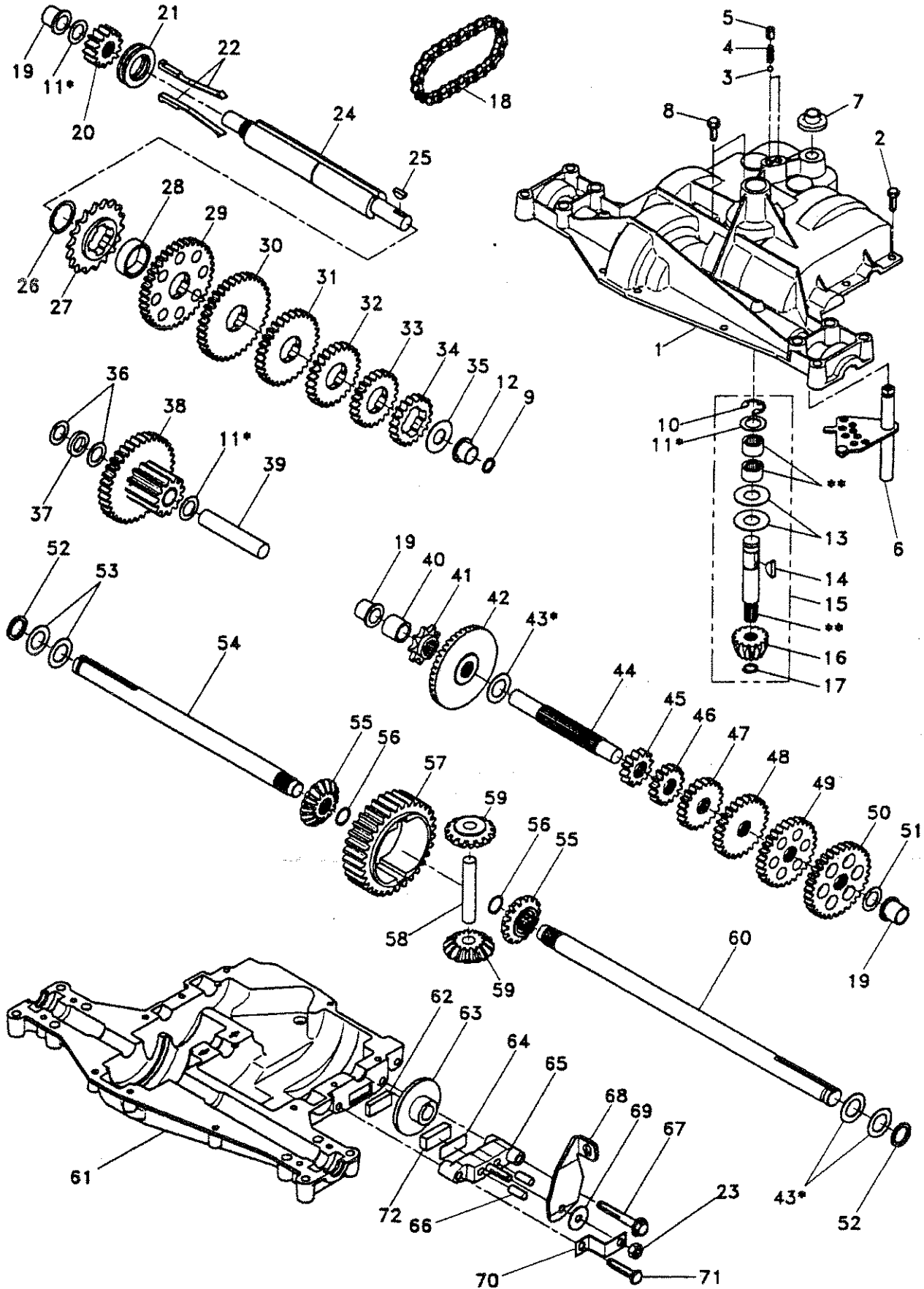

# REPAIR PARTS

TRACTOR - - MODEL NUMBER 917.256410

DANA TRANSAXLE - MODEL NUMBER 4360-79

KEY PART NO. NO.	DESCRIPTION	KEY PART NO. NO.	DESCRIPTION
1 142671	Housing, Upper	41 105928X	Sprocket, 9 Teeth (Reverse)
2 2274J	Screw, Self-Tapping, Large 1/4-20 x .734	42 110084X	Gear, Bevel, 42 Teeth
3 134400	Ball, Detent	43 134394	* Assembly, Kit, Shim .750 Shaft
4 105904X	Spring, Detent	44 120473X	Shaft, Drive
5 105905X	Screw, Set	45 142678	Gear, Spur, 12 Teeth (1 <sup>n</sup> )
6 138235	Kit, Shifter Assembly	46 142679	Gear, Spur, 15 Teeth (2 <sup>n</sup> )
7 134399	Boot, Shifter	47 120407X	Gear, Spur, 20 Teeth (3 <sup>n</sup> )
8 134791	Screw, Tapping w/Sealer	48 106589X	Gear, Spur, 25 Teeth (4 <sup>n</sup> )
9 138241	Square Ring	49 120408X	Gear, Spur, 28 Teeth (5 <sup>n</sup> )
10 142672	Ring, Retaining	50 105937X	Gear, Spur, 31 Teeth (6 <sup>n</sup> )
11 134793	* Assembly, Kit, Shim .625 Shaft	51 2226J	Washer, Plain .632 x 1.00 x .060
12 142673	Bearing, Flange	52 134401	Washer, Neoprene
13 120415X	Washer, Plain .632 x 1.38 x .046	53 2264J	Washer, Plain .758 x 1.25 x .031
14 142674	Key, Woodruff, #9	54 120474X	Axle, L.H.
15 138234	Assembly, Kit, Input Shaft	55 110081X	Gear, Miter, 15 Teeth
16 110078X	Pinion, Bevel, 14 Teeth	56 105941X	Ring, Retaining
17 105909X	Ring, Retaining	57 110071X	Gear, Spur, 32 Teeth
18 105910X	Chain, 24 Pitches	58 120952X	Shaft, Cross
19 105911X	Bearing, Flange	59 110082X	Gear, Miter, 15 Teeth
20 142675	Gear, Spur, 14 Teeth	60 120475X	Axle, R.H.
21 138246	Collar, Clutch	61 142680	Housing, Lower
22 138236	Assembly, Kit, Clutch Keys	62 120961X	Puck, Friction
23 73810500	Locknut 5/16-24	63 7294J	Disc, Brake
24 142676	Shaft, Intermediate	64 108989X	Spacer
25 2244J	Key, Woodruff, #61	65 120953X	Jaw, Brake
26 105916X	Ring, Retaining	66 120954X	Pin, Dowel
27 120470X	Sprocket, 18 Teeth (Reverse)	67 134799	Screw, Self-Tapping, Large 5/16-18 x 2.25
28 110070X	Spacer	68 138244	Lever, Actuating
29 142677	Gear, Spur, 37 Teeth (1 <sup>n</sup> )	69 108996X	Washer, Plain .321 x 1.00 x .055
30 142681	Gear, Spur, 35 Teeth (2 <sup>n</sup> )	70 120956X	Bracket, Anti-Rotation
31 120405X	Gear, Spur, 30 Teeth (3 <sup>n</sup> )	71 106596X	Screw, Self-Tapping, Large 5/16-18 x 1.44
32 108980X	Gear, Spur, 25 Teeth (4 <sup>n</sup> )	72 120951X	Puck, Friction
33 120406X	Gear, Spur, 22 Teeth (5 <sup>n</sup> )	73 120416X	Grease
34 134796	Gear, Spur, 19 Teeth (6 <sup>n</sup> )		
35 105925X	Washer, Plain .640 x 1.37 x .061		
36 2232J	Washer, Plain .632 x 1.00 x .026		
37 108978X	Spacer .630 x 1.00 x .169		
38 110079X	Assembly, Gear, Combination of 12 Teeth and 35 Teeth		
39 124639X	Shaft, Idler		
40 120472X	Spacer .635 x .875 x .755		

\* Use in combinations to maintain proper clearances

\*\* Order Key No. 15

**NOTE:** All component dimensions given in U.S. inches  
1 inch = 25.4 mm

# REPAIR PARTS

TRACTOR - - MODEL NUMBER 917.256410

BRIGGS & STRATTON ENGINE - MODEL NUMBER 28R707, TYPE NUMBER 0637-A1

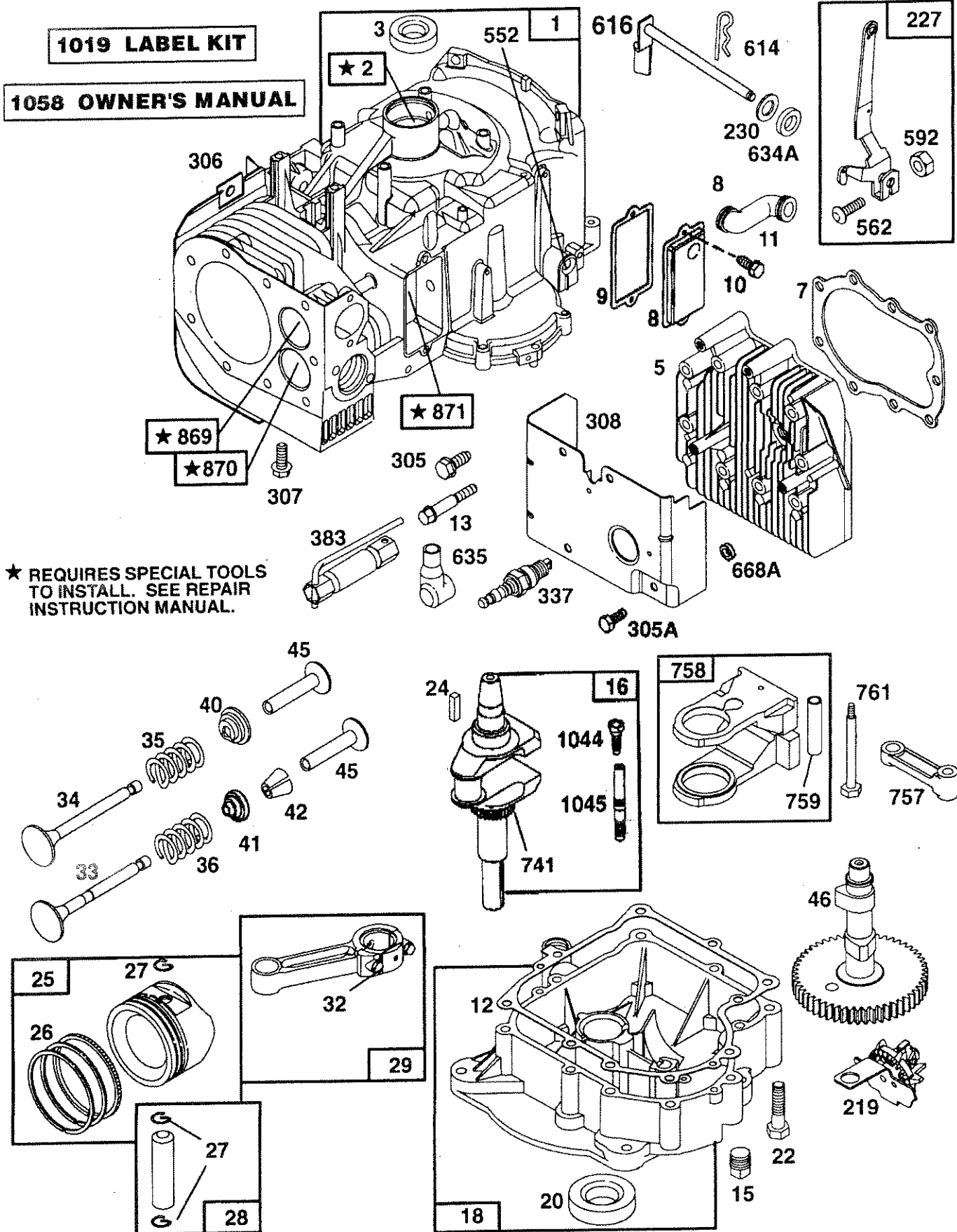



# REPAIR PARTS

TRACTOR -- MODEL NUMBER 917.256410

BRIGGS & STRATTON ENGINE - MODEL NUMBER 28R707, TYPE NUMBER 0637-A1

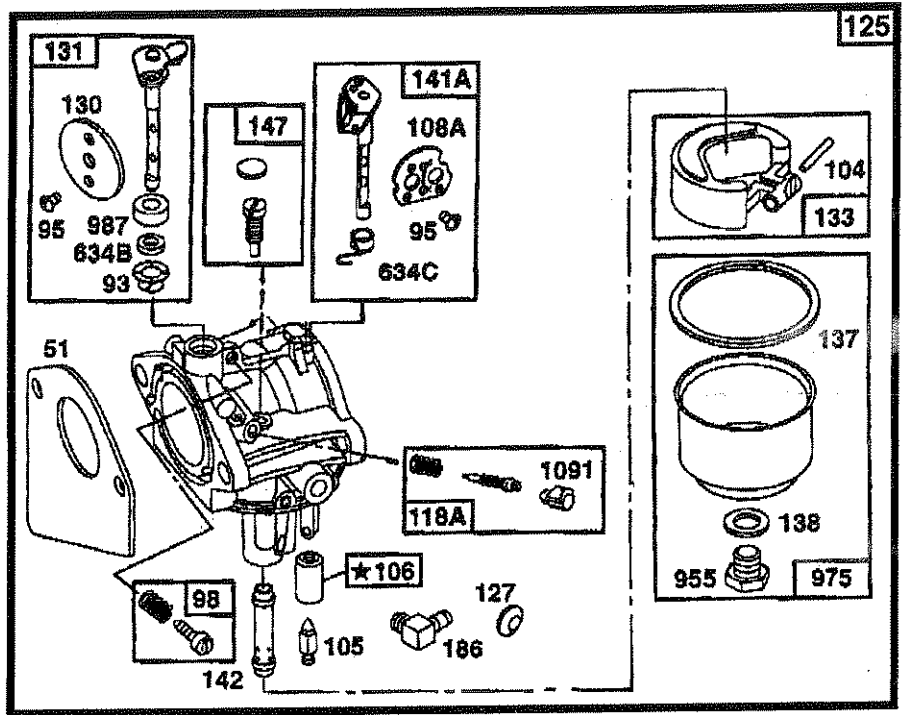
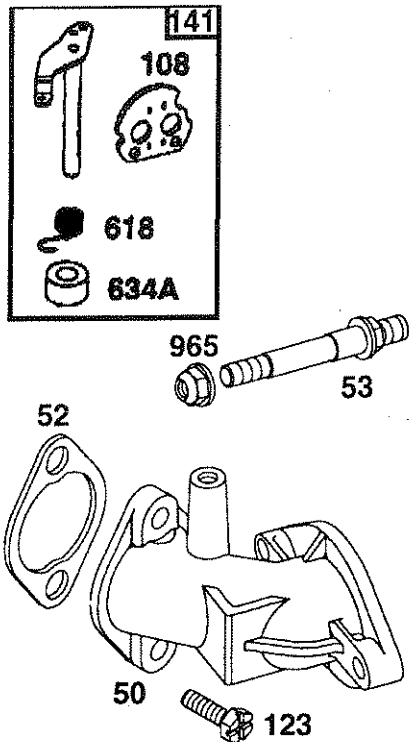

★ REQUIRES SPECIAL TOOLS TO INSTALL. SEE REPAIR INSTRUCTION MANUAL.

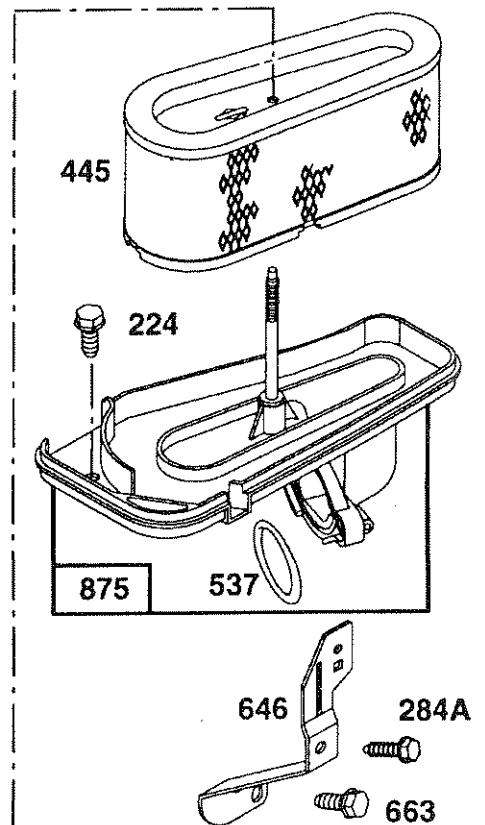
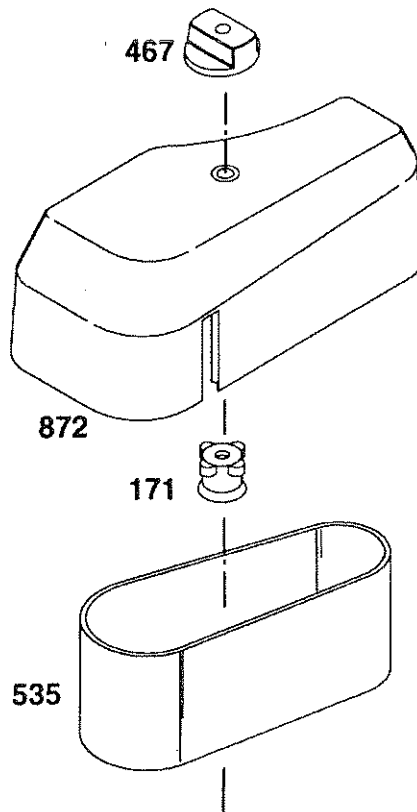
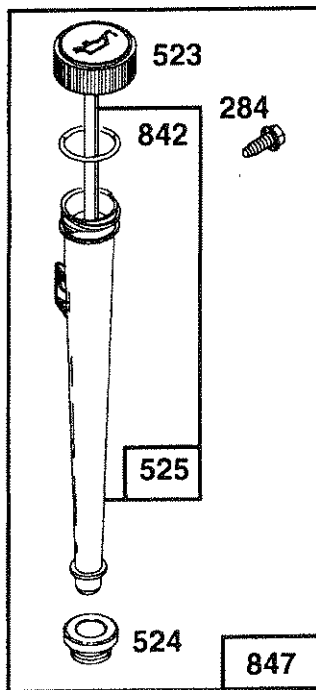

# REPAIR PARTS

TRACTOR -- MODEL NUMBER 917.256410

BRIGGS & STRATTON ENGINE - MODEL NUMBER 28R707, TYPE NUMBER 0637-A1

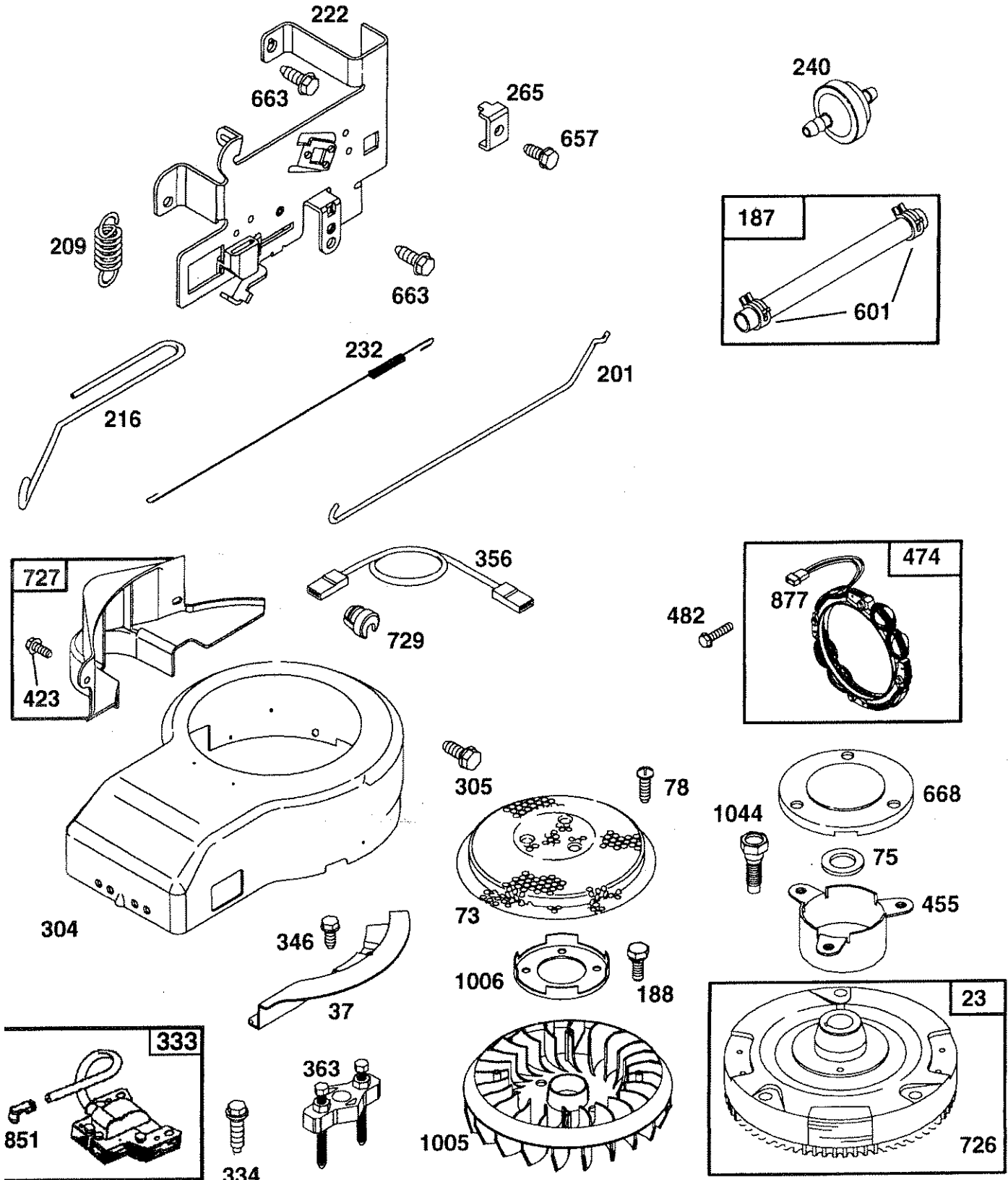

# REPAIR PARTS

TRACTOR - - MODEL NUMBER 917.256410

BRIGGS & STRATTON ENGINE - MODEL NUMBER 28R707, TYPE NUMBER 0637-A1

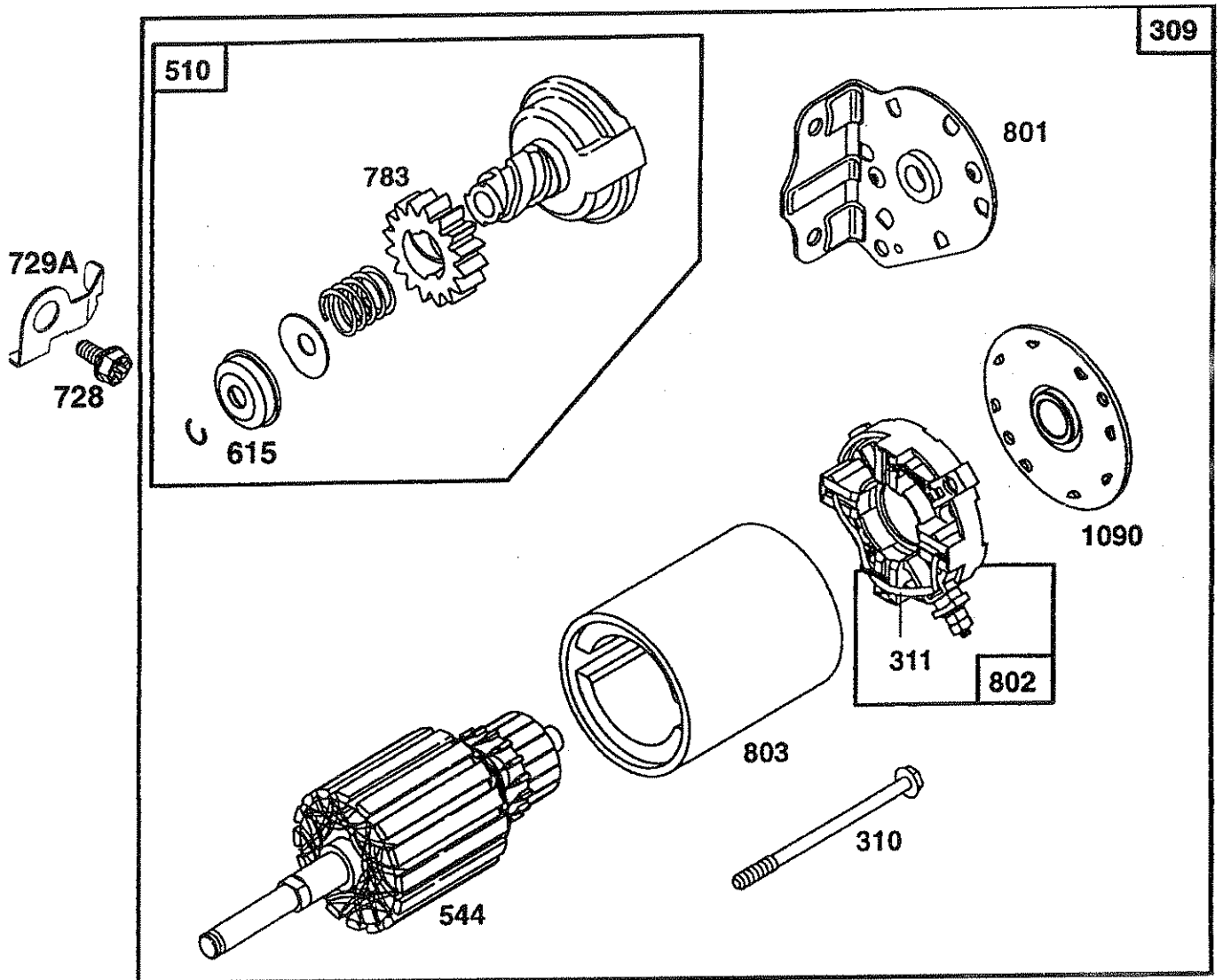

# REPAIR PARTS

## TRACTOR - - MODEL NUMBER 917.256410

### BRIGGS & STRATTON ENGINE - MODEL NUMBER 28R707, TYPE NUMBER 0637-A1

KEY PART NO.	NO.	DESCRIPTION	KEY PART NO.	NO.	DESCRIPTION
1	496413	Cylinder Assembly	52	272554	* Gasket, Carburetor
2	399265	Bearing, Cylinder	53	94637	Stud, Carburetor Mounting
3	391086	* Seal, Oil	73	224948	Screen, Rotating
5	494240	Head, Cylinder	75	225136	Washer, Spring
	94881	Screw, Hex (Qty. 1) (Key No. 305A)	78	94626	Screw, Sems
	231109	Spacer (Qty. 1) (Key No. 668A)	93	281346	Bushing, Throttle Shaft
7	271866	* Gasket, Cylinder Head	95	94098	** Screw, Throttle
8	495735	Breather Assembly (Includes Mounting Gasket)	98	495800	Screw, Idle Adjust
9	27803	* Gasket, Valve Cover	104	231789	** Pin, Float Hinge
10	94621	Screw, Sems	105	231855	** Valve, Inlet Needle
11	280100	Tube, Breather	106	231854	** Seat, Inlet
12	271916	* Gasket, Crankcase Cover, 1/64"	108	224540	Valve, Choke
	271997	* Gasket, Crankcase Cover, .005"	108A	224558	Valve, Choke
	271996	* Gasket, Crankcase Cover, .009"	118	498030	Valve, Needle
13	94622	Screw, Cylinder Head	121	497535	Carburetor Kit
15	94239	Plug, Oil Drain	123	94913	Screw, Elbow Mounting
16	495162	Crankshaft	125	498027	Carburetor
	94196	Key, Timing Gear	127	- - -	** Plug, Welch (Sold in Kit Only)
18	494238	Base, Engine	130	224539	Valve, Throttle
20	291675	* Seal, Oil	131	494379	Shaft, Throttle
22	94624	Screw, Sems, Base Mounting	133	494381	Float, Carburetor
23	492326	Flywheel	137	281165	*** Gasket, Float Bowl
24	222698	Key, Flywheel	138	281164	*** Washer, Float Bowl
25	394661	Piston Assembly, Standard Size	141	495931	Shaft, Choke
	394662	Piston Assembly, .010" Oversize	141A	494380	Shaft, Choke
	394663	Piston Assembly, .020" Oversize	142	497736	** Nozzle, Carburetor
	394664	Piston Assembly, .030" Oversize	142A	497737	Nozzle, Carburetor (High Altitude)
26	391780	Ring Set, Standard Size	147	498239	** Pilot, Jet
	392331	Ring Set, Standard Size, Chrome	171	281051	Nut, Air Cleaner
	391781	Ring Set, .010" Oversize	186	494451	Elbow, Fuel Pipe
	391782	Ring Set, .020" Oversize	187	393815	Line, Fuel (11" Long, Cut to Suit)
	391783	Ring Set, .030" Oversize	188	94627	Screw, Sems
27	260924	Lock, Piston Pin	201	262767	Link, Governor
28	299691	Pin, Piston, Standard Size	209	260871	Spring, Governor
	391286	Pin, Piston, .005" Oversize	216	262766	Link, Choke
29	490348	Rod, Connecting	219	490815	Gear, Governor
	490469	Rod, Connecting, .020" Undersize	222	495611	Plate, Governor Control
32	94671	Screw, Connecting Rod	224	94729	Screw, Hex Head
33	262246	Valve, Exhaust	227	493935	Lever Assembly, Governor
34	262247	Valve, Intake	230	94927	Washer, Governor Crank
35	65906	Spring, Valve	232	262785	Spring, Governor Link
36	26828	Spring, Valve	240	394358	Filter, Fuel
37	224502	Guard, Flywheel	265	221535	Clamp, Casing
40	221596	Retainer, Intake Valve			* Included in Gasket Set (494241)
41	292260	Rotocoil, Exhaust Valve			** Included in Carburetor Kit (497535)
42	494553	Retainer, Rotocoil			*** Included in both Carburetor Kit (497535), and Carburetor Gasket Set (494385)
45	262248	Tappet, Valve			
46	212897	Gear, Cam			
50	213819	Carburetor, Elbow			
51	272465	*** Gasket, Carburetor			

**NOTE:** All component dimensions given in U.S. inches  
1 inch = 25.4 mm

# REPAIR PARTS

## TRACTOR - - MODEL NUMBER 917.256410

### BRIGGS & STRATTON ENGINE - MODEL NUMBER 28R707, TYPE NUMBER 0637-A1

KEY PART NO. NO.	DESCRIPTION	KEY PART NO. NO.	DESCRIPTION
284 94903	Screw, Hex Head	668 280848	Spacer
284A 94704	Screw, Hex Head	668A 231109	Spacer
304 496280	Housing, Blower	726 392134	Gear, Ring
305 94786	Screw, Hex Head	727 490324	Cover, Starter
305A 94881	Screw, Hex	728 94951	Screw, Torx®
306 224545	Shield, Cylinder	729 281159	Clip, Lead Wire
307 94930	Screw, Sems	729A 225170	Retainer, Wire
308 491490	Cover, Cylinder Head	741 262932	Gear, Timing
309 497595	Motor, Starter	757 213998	Link, Counterweight
310 497602	Thru Bolt Assembly	758 399891	Counterweight Assembly
311 497608	Brush Assembly	759 298909	Pin, Counterweight
333 492341	Armature, Magneto	761 94593	Screw, Counterweight
334 93381	Screw, Sems	783 280104	Gear
337 802592	Plug, Spark	801 394856	Cap, Drive
346 94896	Screw, Hex Head	802 497605	Cap, End
356 494328	Wire Assembly	803 497604	Housing, Starter
358 494241	Gasket Set	842 270920	* Seal, Cap
363 19203	Puller, Flywheel	847 496415	Tube Assembly, Oil
383 89838	Wrench, Spark Plug	851 493880	Terminal, Ignition Cable
423 94903	Screw, Shoulder	869 261463	Seat, Intake Valve
445 496894	Cartridge, Air Cleaner	870 213316	Seat, Exhaust Valve
455 222561	Cup, Screen Mounting	871 261961	Guide, Exhaust Valve
467 493903	Knob, Air Cleaner	231218	Guide, Intake Valve, Brass
474 393474	Stator, Alternator	872 281361	Cover, Air Cleaner
482 93621	Screw, Sems	875 494237	Body, Air Cleaner
510 497606	Starter Drive Group	877 393456	Diode Assembly
523 495230	Dipstick, Oil	955 94642	Screw, Fuel Bowl
524 281370	* Seal, Oil	965 94010	Nut, Hex
525 496113	Tube, Oil Filler	975 494378	Bowl, Float
535 272403	Element, Filter	977 494385	Carburetor Gasket Set
537 281106	* O-Ring, Air Cleaner	987 281166	** Seal, Throttle Shaft
544 497603	Armature, Starter	1005 281355	Fan, Flywheel
552 491986	Bushing, Governor Crank	1006 224413	Retainer, Fan
562 92613	Bolt, Governor Lever	1019 491252	Label Kit
592 231082	Nut, Hex	1044 94673	Screw, Hex Head
601 93053	Clamp, Fuel Pipe	1045 231828	Extension, Crankshaft
614 93306	Pin, Cotter	1058 272697	Manual, Owner's
615 263080	Retainer	1090 497607	Retainer, Brush
616 495157	Crank, Governor	1091 281364	Cap, Limiter
618 262803	Spring, Choke Return		
634 281168	** Seal, Choke Shaft		RPM Settings: Low Speed: 1900-2100
634A 491323	* Seal, Governor		High Speed: 3000-3200
634B 398970	** Washer, Throttle Shaft		
634C 494453	* Seal, Spring Assembly		* Included in Gasket Set (494241)
635 66538	Elbow, Spark Plug		** Included in Carburetor Kit (497535)
646 224546	Brace, Air Cleaner		*** Included in both Carburetor Kit (497535), and Carburetor Gasket Set (494385)
657 94906	Screw, Sems		
663 94929	Screw, Hex Head		

**NOTE:** All component dimensions given in U.S. inches  
1 inch = 25.4 mm

---

# SERVICE NOTES

---

# SUGGESTED GUIDE FOR SIGHTING SLOPES FOR SAFE OPERATION

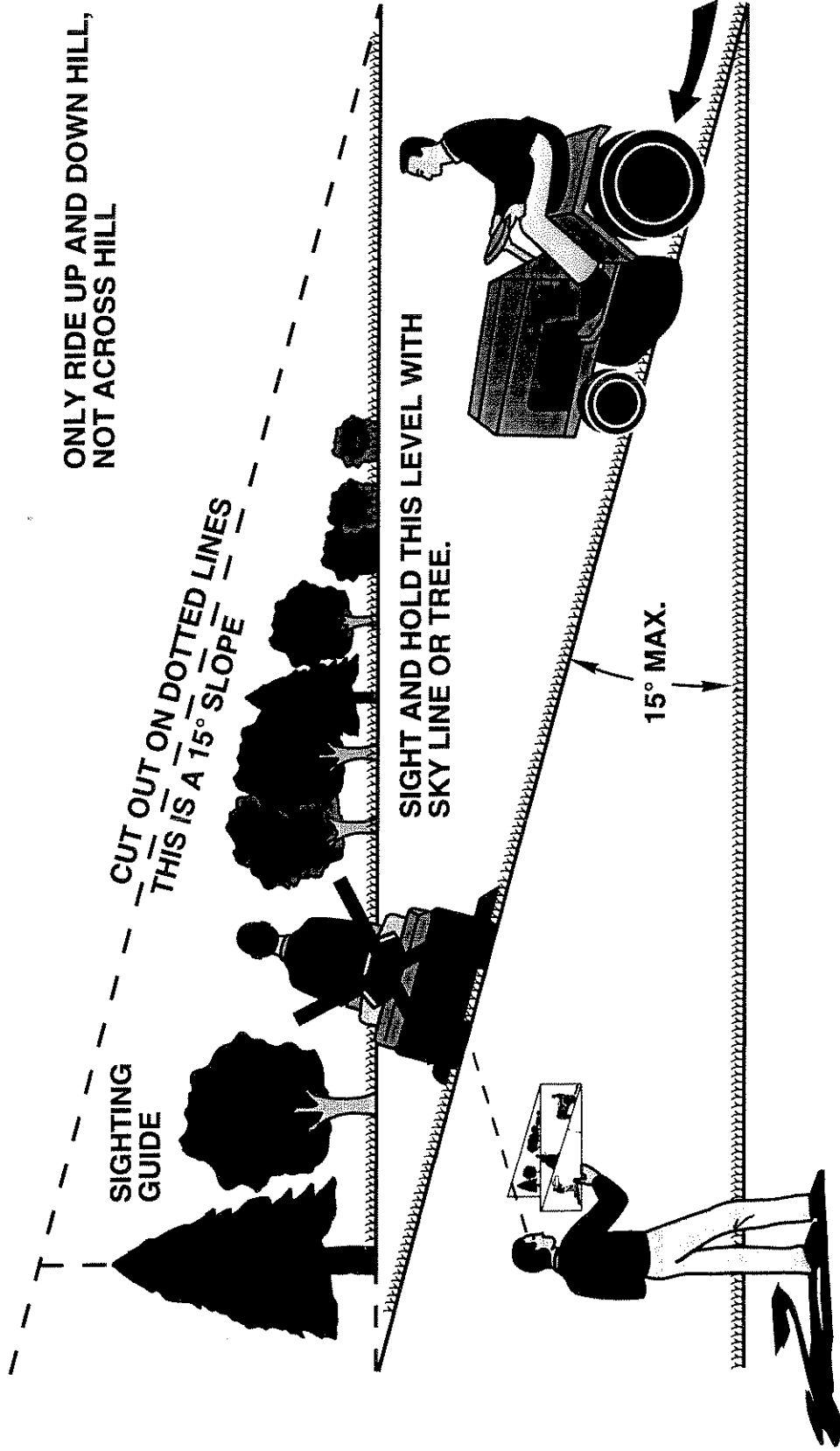

 Operate your Tractor up and down the face of slopes (not greater than 15°), never across the face. Make turns gradually to prevent tipping or loss of control. Exercise extreme caution when changing direction on slopes.

**SEARS**  
**OWNER'S**  
**MANUAL**

**MODEL NO.**  
**917.256410**

**IF YOU NEED**  
**REPAIR SERVICE**  
**OR PARTS:**

FOR REPAIR SERVICE, CALL  
THIS TOLL FREE NUMBER:

**1-800-4-REPAIR**  
(1-800-473-7247)

FOR REPLACEMENT PARTS  
INFORMATION AND  
ORDERING, CALL THIS  
TOLL FREE NUMBER:

**1-800-FON-PART**  
(1-800-366-7278)

FOR CONSUMER ASSISTANCE  
HOT LINE, CALL THIS  
TOLL FREE NUMBER:

**1-800-659-5917**

**CRAFTSMAN®**

**13.5 HP IC**  
**ELECTRIC START**  
**42" MOWER**  
**6 SPEED TRANSAXLE**  
**LAWN TRACTOR**

Each tractor has its own model number. Each engine has its own model number.

The model number for your tractor will be found on the model plate located under the seat.

The model number for your engine will be found on the blower housing of the engine.

All parts listed herein may be ordered from any Sears, Roebuck and Co. Service Center/Department and most Retail Stores.

**WHEN ORDERING REPAIR PARTS, ALWAYS GIVE THE**  
**FOLLOWING INFORMATION:**

- **PRODUCT - TRACTOR**
- **MODEL NUMBER - 917.256410**
- **ENGINE MODEL NO. - 28R707, TYPE NO. 0637-A1**
- **PART NUMBER**
- **PART DESCRIPTION**

Your Sears merchandise has added value when you consider Sears has service units nationwide staffed with Sears trained technicians... professional technicians specifically trained to insure that we meet our pledge to you, we service what we sell.