

SEARS
OWNER'S
MANUAL

MODEL NO.
944.606912

Important:
Read and follow
all Safety Rules
and Instructions
Before Operating
This Equipment

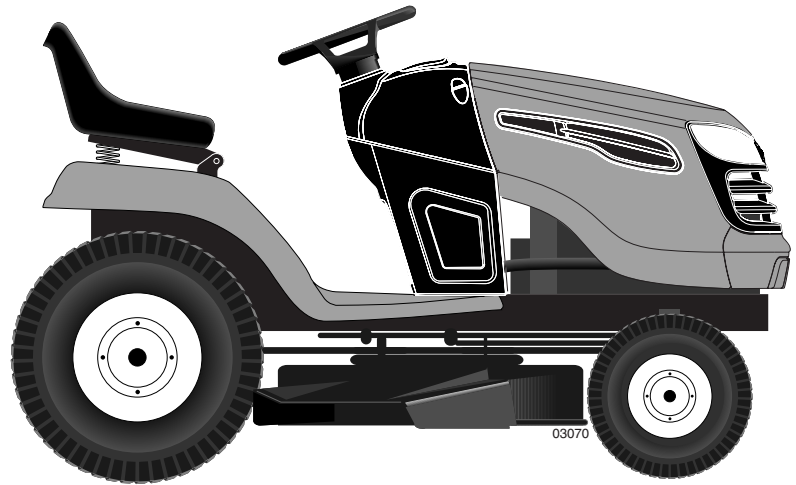

CRAFTSMAN®

**20.0 HP
ELECTRIC START
42" MOWER
AUTOMATIC TRANSMISSION
LAWN TRACTOR**

- Assembly
- Operation
- Maintenance
- Service and Adjustments
- Repair Parts



SAFETY RULES



Safe Operation Practices for Ride-On Mowers

DANGER: THIS CUTTING MACHINE IS CAPABLE OF AMPUTATING HANDS AND FEET AND THROWING OBJECTS. FAILURE TO OBSERVE THE FOLLOWING SAFETY INSTRUCTIONS COULD RESULT IN SERIOUS INJURY OR DEATH.



WARNING: In order to prevent accidental starting when setting up, transporting, adjusting or making repairs, always disconnect spark plug wire and place wire where it cannot contact spark plug.



WARNING: Do not coast down a hill in neutral, you may lose control of the tractor.



WARNING: Tow only the attachments that are recommended by and comply with specifications of the manufacturer of your tractor. Use common sense when towing. Operate only at the lowest possible speed when on a slope. Too heavy of a load, while on a slope, is dangerous. Tires can lose traction with the ground and cause you to lose control of your tractor.

I. GENERAL OPERATION

- Read, understand, and follow all instructions on the machine and in the manual before starting.
- Do not put hands or feet near rotating parts or under the machine. Keep clear of the discharge opening at all times.
- Only allow responsible adults, who are familiar with the instructions, to operate the machine.
- Clear the area of objects such as rocks, toys, wire, etc., which could be picked up and thrown by the blades.
- Be sure the area is clear of bystanders before operating. Stop machine if anyone enters the area.
- Never carry passengers.
- Do not mow in reverse unless absolutely necessary. Always look down and behind before and while backing.
- Never direct discharged material toward anyone. Avoid discharging material against a wall or obstruction. Material may ricochet back toward the operator. Stop the blades when crossing gravel surfaces.
- Do not operate machine without the entire grass catcher, discharge guard, or other safety devices in place and working.
- Slow down before turning.
- Never leave a running machine unattended. Always turn off blades, set parking brake, stop engine, and remove keys before dismounting.
- Disengage blades when not mowing. Shut off engine and wait for all parts to come to a complete stop before cleaning the machine, removing the grass catcher, or unclogging the discharge guard.
- Operate machine only in daylight or good artificial light.
- Do not operate the machine while under the influence of alcohol or drugs.
- Watch for traffic when operating near or crossing roadways.
- Use extra care when loading or unloading the machine into a trailer or truck.
- Always wear eye protection when operating machine.

- Data indicates that operators, age 60 years and above, are involved in a large percentage of riding mower-related injuries. These operators should evaluate their ability to operate the riding mower safely enough to protect themselves and others from serious injury.
- Follow the manufacturer's recommendation for wheel weights or counterweights.
- Keep machine free of grass, leaves or other debris build-up which can touch hot exhaust / engine parts and burn. Do not allow the mower deck to plow leaves or other debris which can cause build-up to occur. Clean any oil or fuel spillage before operating or storing the machine. Allow machine to cool before storage.

II. SLOPE OPERATION

Slopes are a major factor related to loss of control and tip-over accidents, which can result in severe injury or death. Operation on all slopes requires extra caution. If you cannot back up the slope or if you feel uneasy on it, do not mow it.

- Mow up and down slopes, not across.
- Watch for holes, ruts, bumps, rocks, or other hidden objects. Uneven terrain could overturn the machine. Tall grass can hide obstacles.
- Choose a low ground speed so that you will not have to stop or shift while on the slope.
- Do not mow on wet grass. Tires may lose traction. Always keep the machine in gear when going down slopes. Do not shift to neutral and coast downhill.
- Avoid starting, stopping, or turning on a slope. If the tires lose traction, disengage the blades and proceed slowly straight down the slope.
- Keep all movement on the slopes slow and gradual. Do not make sudden changes in speed or direction, which could cause the machine to roll over.
- Use extra care while operating machine with grass catchers or other attachments; they can affect the stability of the machine. Do no use on steep slopes.
- Do not try to stabilize the machine by putting your foot on the ground.
- Do not mow near drop-offs, ditches, or embankments. The machine could suddenly roll over if a wheel is over the edge or if the edge caves in.

III. CHILDREN

Tragic accidents can occur if the operator is not alert to the presence of children. Children are often attracted to the machine and the mowing activity. *Never* assume that children will remain where you last saw them.

- Keep children out of the mowing area and in the watchful care of a responsible adult other than the operator.
- Be alert and turn machine off if a child enters the area.
- Before and while backing, look behind and down for small children.
- Never carry children, even with the blades shut off. They may fall off and be seriously injured or interfere with safe machine operation. Children who have been given rides in the past may suddenly appear in the mowing area for another ride and be run over or backed over by the machine.
- Never allow children to operate the machine.
- Use extra care when approaching blind corners, shrubs, trees, or other objects that may block your view of a child.



SAFETY RULES

Safe Operation Practices for Ride-On Mowers



IV. TOWING

- Tow only with a machine that has a hitch designed for towing. Do not attach towed equipment except at the hitch point.
- Follow the manufacturer's recommendation for weight limits for towed equipment and towing on slopes.
- Never allow children or others in or on towed equipment.
- On slopes, the weight of the towed equipment may cause loss of traction and loss of control.
- Travel slowly and allow extra distance to stop.

V. SERVICE

SAFE HANDLING OF GASOLINE

To avoid personal injury or property damage, use extreme care in handling gasoline. Gasoline is extremely flammable and the vapors are explosive.

- Extinguish all cigarettes, cigars, pipes, and other sources of ignition.
- Use only approved gasoline container.
- Never remove gas cap or add fuel with the engine running. Allow engine to cool before refueling.
- Never fuel the machine indoors.
- Never store the machine or fuel container where there is an open flame, spark, or pilot light such as on a water heater or other appliances.
- Never fill containers inside a vehicle or on a truck or trailer bed with plastic liner. Always place containers on the ground away from your vehicle when filling.
- Remove gas-powered equipment from the truck or trailer and refuel it on the ground. If this is not possible, then refuel such equipment with a portable container, rather than from a gasoline dispenser nozzle.
- Keep the nozzle in contact with the rim of the fuel tank or container opening at all times until fueling is complete. Do not use a nozzle lock-open device.
- If fuel is spilled on clothing, change clothing immediately.
- Never overfill fuel tank. Replace gas cap and tighten securely.

GENERAL SERVICE

- Never operate machine in a closed area.
- Keep all nuts and bolts tight to be sure the equipment is in safe working condition.
- Never tamper with safety devices. Check their proper operation regularly.
- Keep machine free of grass, leaves, or other debris build-up. Clean oil or fuel spillage and remove any fuel-soaked debris. Allow machine to cool before storing.
- If you strike a foreign object, stop and inspect the machine. Repair, if necessary, before restarting.

- Never make any adjustments or repairs with the engine running.
- Check grass catcher components and the discharge guard frequently and replace with manufacturer's recommended parts, when necessary.
- Mower blades are sharp. Wrap the blade or wear gloves, and use extra caution when servicing them.
- Check brake operation frequently. Adjust and service as required.
- Maintain or replace safety and instruction labels, as necessary.



- Be sure the area is clear of bystanders before operating. Stop machine if anyone enters the area.
- Never carry passengers.
- Do not mow in reverse unless absolutely necessary. Always look down and behind before and while backing.
- Never carry children, even with the blades shut off. They may fall off and be seriously injured or interfere with safe machine operation. Children who have been given rides in the past may suddenly appear in the mowing area for another ride and be run over or backed over by the machine.
- Keep children out of the mowing area and in the watchful care of a responsible adult other than the operator.
- Be alert and turn machine off if a child enters the area.
- Before and while backing, look behind and down for small children.
- Mow up and down slopes (15° Max), not across.
- Choose a low ground speed so that you will not have to stop or shift while on the slope.
- Avoid starting, stopping, or turning on a slope. If the tires lose traction, disengage the blades and proceed slowly straight down the slope.
- If machine stops while going uphill, disengage blades, shift into reverse and back down slowly.
- Do not turn on slopes unless necessary, and then, turn slowly and gradually downhill, if possible.

TABLE OF CONTENTS

SAFETY RULES	2-3
PRODUCT SPECIFICATIONS	4
CUSTOMER RESPONSIBILITIES	4
WARRANTY	4
ASSEMBLY	5-7
OPERATION	8-13
MAINTENANCE SCHEDULE	14

MAINTENANCE	14-17
SERVICE AND ADJUSTMENTS	18-23
STORAGE	24
TROUBLESHOOTING	25-26
REPAIR PARTS - TRACTOR	28-43
REPAIR PARTS - ENGINE.....	44-48
PARTS ORDERING/SERVICE.....	
BACK COVER.....	

PRODUCT SPECIFICATIONS

Gasoline Capacity and type:	2.50 Gallons Unleaded Regular
Oil Type (API-SG-SL):	SAE 30 (above 32°F) SAE 5W-30 (below 32°F) Synthetic (below 0°F)
Your tractor was shipped from the factory with non-synthetic SAE 10W30 motor oil	
Oil Capacity:	W/Filter: 4.0 Pints W/O Filter: 3.75 Pints
Spark Plug: (Gap: .030")	Champion QC12YC
Ground Speed (MPH):	Forward: 0-5.5 Reverse: 0-2.4
Charging System:	3 Amps Battery 5 Amps Headlights
Battery:	AMP/HR: 35 Min. CCA: 280 Case Size: U1R
Blade Bolt Torque:	45-55 FT. LBS.

CONGRATULATIONS on your purchase of a new Tractor. It has been designed, engineered and manufactured to give you the best possible dependability and performance.

Should you experience any problem you cannot easily remedy, please contact your nearest authorized service center/department. We have competent, well-trained technicians and the proper tools to service or repair this tractor.

Please read and retain this manual. The instructions will enable you to assemble and maintain your tractor properly. Always observe the "SAFETY RULES".

MAINTENANCE AGREEMENT

A Maintenance Agreement is available on this product. Contact your nearest Sears store for details.

CUSTOMER RESPONSIBILITIES

- Read and observe the safety rules.
- Follow a regular schedule in maintaining, caring for and using your tractor.
- Follow the instructions under "Maintenance" and "Storage" sections of this owner's manual.

WARNING: This tractor is equipped with an internal combustion engine and should not be used on or near any unimproved forest-covered, brush-covered or grass-covered land unless the engine's exhaust system is equipped with a spark arrester meeting applicable local or state laws (if any). If a spark arrester is used, it should be maintained in effective working order by the operator.

A spark arrester for the muffler is available through your nearest authorized service center/department (See REPAIR PARTS section of this manual).

LIMITED TWO (2) YEAR WARRANTY ON CRAFTSMAN TRACTOR (RIDING EQUIPMENT)

For two (2) years from date of purchase Sears Canada, Inc. will repair or replace at Sears option free of charge parts which are defective as a result of material or workmanship.

FULL ONE (1) YEAR WARRANTY ON BATTERY

For one (1) year from date of purchase, if any battery included with this riding equipment proves defective in material or workmanship and our testing determines the battery will not hold a charge, Sears will replace the battery at no charge.

COMMERCIAL OR RENTAL USE

Warranty on Riding Equipment used for commercial or rental purposes is limited to ninety (90) days.

This Warranty does NOT cover:

1. Pre-delivery set-up.
2. Tire replacement or repair caused by punctures from outside objects (such as nails, thorns, stumps, or glass).
3. Expendable items which become worn during normal use, such as blades, spark plug, air cleaners and belts.
4. Repairs necessary because of operator abuse or negligence, including damaged jackshaft or mandrel and the failure to operate and maintain the equipment according to the instructions contained in the Owner's Manual.

Warranty service is available by returning the Craftsman Riding Equipment to the nearest Sears Service Centre/Department in Canada. This warranty applies only while this product is in use in Canada.

This warranty is in addition to any statutory warranty and does not exclude or limit legal rights you may have but shall run concurrently with applicable provincial legislation. Furthermore, some provinces do NOT allow limitation on how long an implied warranty will last so the above limitations may not apply to you.

SEARS CANADA, INC., TORONTO, ONTARIO M5B 2B8

UNASSEMBLED PARTS

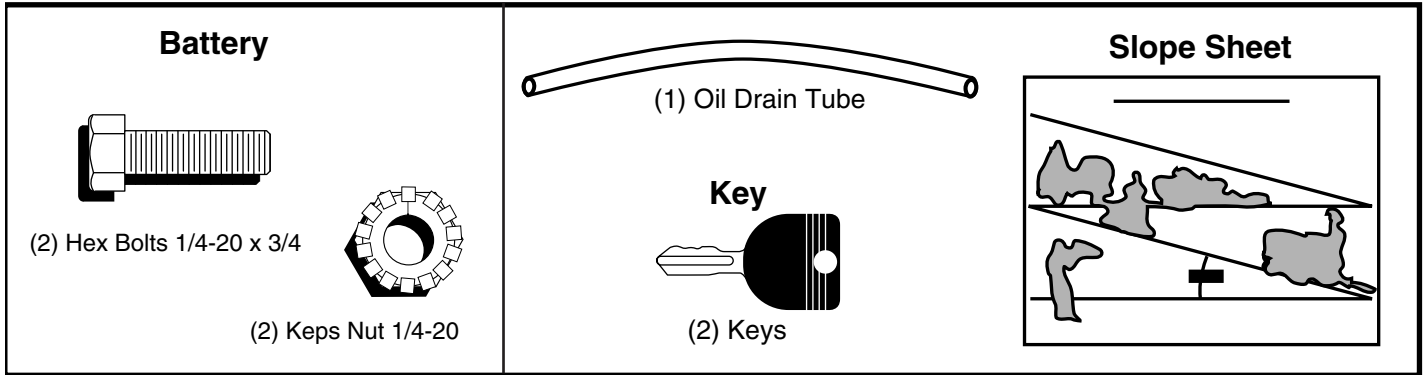

ASSEMBLY

Your new tractor has been assembled at the factory with the exception of those parts left unassembled for shipping purposes.

TOOLS REQUIRED FOR ASSEMBLY

A socket wrench set will make assembly easier. Standard wrench sizes are listed.

(2) 7/16" wrenches

When right or left hand is mentioned in this manual, it means when you are in the operating position (seated behind the steering wheel).

TO REMOVE TRACTOR FROM CARTON

UNPACK CARTON

- Remove all accessible loose parts and parts cartons from carton.
- Cut along dashed lines on all four panels of carton. Remove end panels and lay side panels flat.
- Check for any additional loose parts or cartons and remove.

CONNECT BATTERY (See Fig. 1)



CAUTION: Do not short battery terminals by allowing a wrench or any other object to contact both terminals at the same time. Before connecting battery, remove metal bracelets, wristwatch bands, rings, etc.

Positive terminal must be connected first to prevent sparking from accidental grounding.

- Lift hood to raised position.
- Remove terminal protective caps and discard.

NOTE: If this battery is put into service after month and year indicated on label (L) (label located between terminals) charge battery for minimum of one hour at 6-10 amps.

- First connect RED battery cable to positive (+) terminal with hex bolt and keps nut.

- Connect BLACK grounding cable to negative (-) terminal with remaining hex bolt and keps nut. Tighten securely.

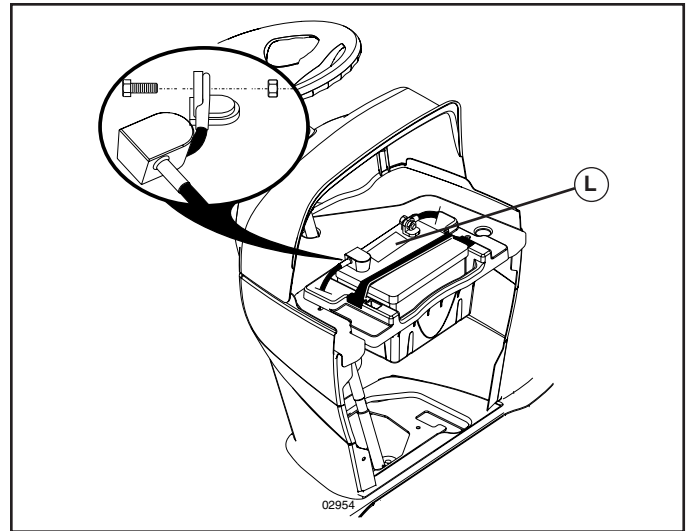

FIG. 1

ADJUST SEAT (See Fig. 2)

- Raise seat and loosen adjustment knob (A).
- Lower seat into operating position and sit in seat.
- Slide seat until a comfortable position is reached which allows you to press clutch/brake pedal all the way down.
- Get off seat without moving its adjusted position.
- Raise seat and tighten adjustment knob securely.

ASSEMBLY

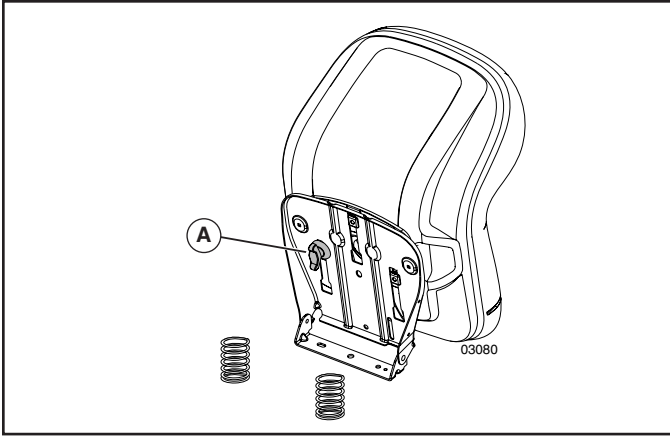

FIG. 2

NOTE: You may now roll or drive your tractor off the skid. Follow the appropriate instruction below to remove the tractor from the skid.

WARNING: Before starting, read, understand and follow all instructions in the Operation section of this manual. Be sure tractor is in a well-ventilated area. Be sure the area in front of tractor is clear of other people and objects.

TO ROLL TRACTOR OFF SKID (See Operation section for location and function of controls)

- Raise attachment lift lever to its highest position.
- Release parking brake by depressing clutch/brake pedal.
- Place freewheel control in "transmission disengaged position" (See "TO TRANSPORT" in the Operation section of this manual).
- Roll tractor forward off skid.
- Remove banding holding the deflector shield up against tractor.

TO DRIVE TRACTOR OFF SKID (See Operation section for location and function of controls)

WARNING: Before starting, read, understand and follow all instructions in the Operation section of this manual. Be sure tractor is in a well-ventilated area. Be sure the area in front of tractor is clear of other people and objects.

- Be sure all the above assembly steps have been completed.
- Check engine oil level and fill fuel tank with gasoline.
- Place freewheel control in "transmission engaged" position (see "TO TRANSPORT" in Operation section of this manual).
- Sit on seat in operating position, depress clutch/brake pedal and set the parking brake.
- Place motion control lever in neutral (N) position.
- Press lift lever plunger and raise attachment lift lever to its highest position.

- Remove key from bag and start the engine (see "TO START ENGINE" in the Operation section of this manual). After engine has started, move throttle control to idle (slow) position.
- Release parking brake.
- Slowly move the motion control lever forward and slowly drive tractor off skid.
- Apply brake to stop tractor, set parking brake and place motion control lever in neutral position.
- Turn ignition key to "STOP" position.

Continue with the instructions that follow.

INSTALL MULCHER PLATE (See Fig. 3)

(If previously removed)

- Raise and hold deflector shield in upright position.
- Place slot in mulcher plate over tab on mower and position plate over mower opening as shown.
- Hook front latch into hole on front of mower deck.
- Hook rear latch into hole on back of mower deck.



CAUTION: Do not remove deflector shield from mower.

TO CONVERT TO BAGGING OR DISCHARGING

Simply remove mulcher plate and store in a safe place. Your mower is now ready for discharging or installation of optional grass catcher accessory.

NOTE: It is not necessary to change blades. The mulcher blades are designed for discharging and bagging also.

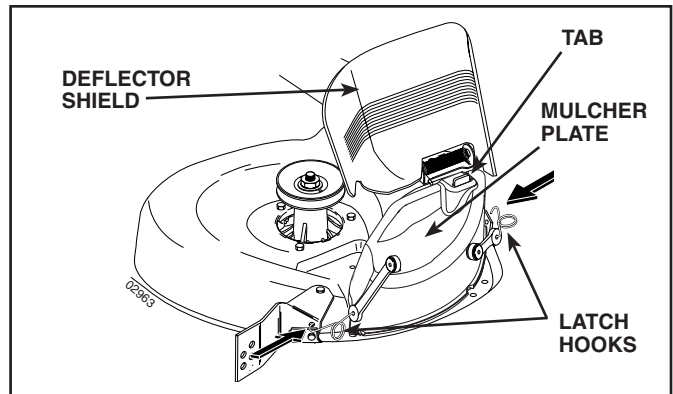

FIG. 3

ASSEMBLY

CHECK TIRE PRESSURE

The tires on your tractor were overinflated at the factory for shipping purposes. Correct tire pressure is important for best cutting performance.

- Reduce tire pressure to PSI shown on tires.

CHECK DECK LEVELNESS

For best cutting results, mower housing should be properly leveled. See "TO LEVEL MOWER HOUSING" in the Service and Adjustments section of this manual.

CHECK FOR PROPER POSITION OF ALL BELTS

See the figures that are shown for replacing motion and mower blade drive belts in the Service and Adjustments section of this manual. Verify that the belts are routed correctly.

CHECK BRAKE SYSTEM

After you learn how to operate your tractor, check to see that the brake is operating properly. See "TO CHECK BRAKE" in the Service and Adjustments section of this manual.

✓ CHECKLIST

BEFORE YOU OPERATE YOUR NEW TRACTOR, WE WISH TO ASSURE THAT YOU RECEIVE THE BEST PERFORMANCE AND SATISFACTION FROM THIS QUALITY PRODUCT.

PLEASE REVIEW THE FOLLOWING CHECKLIST:

- ✓ All assembly instructions have been completed.
- ✓ No remaining loose parts in carton.
- ✓ Battery is properly prepared and charged.
- ✓ Seat is adjusted comfortably and tightened securely.
- ✓ All tires are properly inflated. (For shipping purposes, the tires were overinflated at the factory).
- ✓ Be sure mower deck is properly leveled side-to-side/ front-to-rear for best cutting results. (Tires must be properly inflated for leveling).
- ✓ Check mower and drive belts. Be sure they are routed properly around pulleys and inside all belt keepers.
- ✓ Check wiring. See that all connections are still secure and wires are properly clamped.
- ✓ Before driving tractor, be sure freewheel control is in "transmission engaged" position (see "TO TRANSPORT" in the Operation section of this manual).

WHILE LEARNING HOW TO USE YOUR TRACTOR, PAY EXTRA ATTENTION TO THE FOLLOWING IMPORTANT ITEMS:

- ✓ Engine oil is at proper level.
- ✓ Fuel tank is filled with fresh, clean, regular unleaded gasoline.
- ✓ Become familiar with all controls, their location and function. Operate them before you start the engine.
- ✓ Be sure brake system is in safe operating condition.
- ✓ Be sure Operator Presence System and Reverse Operation System (ROS) are working properly (See the Operation and Maintenance sections in this manual).
- ✓ It is important to purge the transmission before operating your tractor for the first time. Follow proper starting and transmission purging instructions (See "TO START ENGINE" and "PURGE TRANSMISSION" in the Operation section of this manual).

OPERATION

These symbols may appear on your tractor or in literature supplied with the product. Learn and understand their meaning.

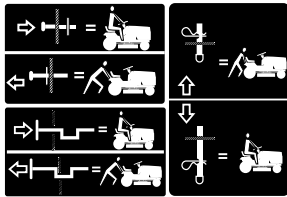

FREE WHEEL
(Automatic Models only)



Failure to follow instructions could result in serious injury or death. The safety alert symbol is used to identify safety information about hazards which can result in death, serious injury and/or property damage.



DANGER indicates a hazard which, if not avoided, will result in death or serious injury.



WARNING indicates a hazard which, if not avoided, could result in death or serious injury.



CAUTION indicates a hazard which, if not avoided, might result in minor or moderate injury.

CAUTION when used **without** the alert symbol, indicates a situation that **could result in damage to the tractor and/or engine.**



HOT SURFACES indicates a hazard which, if not avoided, **could result in death, serious injury and/or property damage.**



FIRE indicates a hazard which, if not avoided, **could result in death, serious injury and/or property damage.**

OPERATION

KNOW YOUR TRACTOR

READ THIS OWNER'S MANUAL AND SAFETY RULES BEFORE OPERATING YOUR TRACTOR

Compare the illustrations with your tractor to familiarize yourself with the locations of various controls and adjustments. Save this manual for future reference.

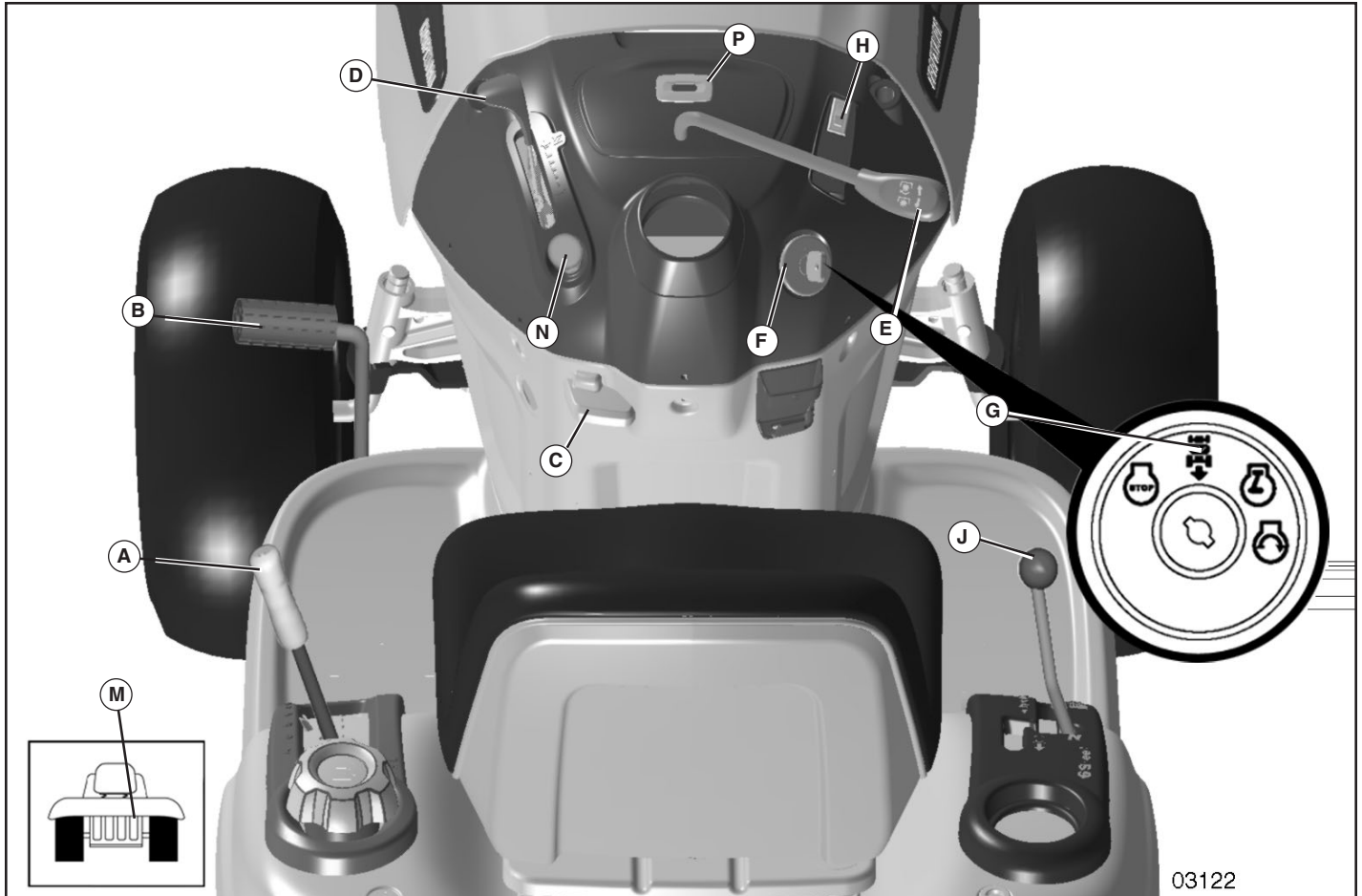

FIG. 4

Our tractors conform to the applicable safety standards of the American National Standards Institute.

(A) ATTACHMENT LIFT LEVER – Used to raise and lower the mower or other attachments mounted to your tractor.

(B) CLUTCH/BRAKE PEDAL – Used for braking the tractor and starting the engine.

(C) PARKING BRAKE – Locks clutch/brake pedal into the brake position.

(D) THROTTLE CONTROL – Used to control engine speed.

(E) ATTACHMENT CLUTCH LEVER – Used to engage the mower blades, or other attachments mounted to your tractor.

(F) IGNITION SWITCH – Used for starting and stopping the engine.

(G) REVERSE OPERATION SYSTEM (ROS) "ON" POSITION – Allows operation of mower or other powered attachment while in reverse.

(H) LIGHT SWITCH – Turns the headlights on and off.

(J) MOTION CONTROL LEVER – Selects the speed and direction of tractor.

(M) FREEWHEEL CONTROL – Disengages transmission for pushing or slowly towing the tractor with the engine off.

(N) CHOKE CONTROL - Used when starting a cold engine.

(P) SERVICE REMINDER / HOUR METER – Indicates when service is required for the engine and mower.

OPERATION



The operation of any tractor can result in foreign objects thrown into the eyes, which can result in severe eye damage. Always wear safety glasses or eye shields while operating your tractor or performing any adjustments or repairs. We recommend standard safety glasses or a wide vision safety mask worn over spectacles.

HOW TO USE YOUR TRACTOR

TO SET PARKING BRAKE (See Fig. 5)

Your tractor is equipped with an operator presence sensing switch. When engine is running, any attempt by the operator to leave the seat without first setting the parking brake will shut off the engine.

1. Depress clutch/brake pedal (B) all the way down and hold.
2. Pull parking brake lever (C) up and hold, release pressure from clutch/brake pedal (B), then release parking brake lever. Pedal should remain in brake position. Make sure parking brake will hold tractor secure.

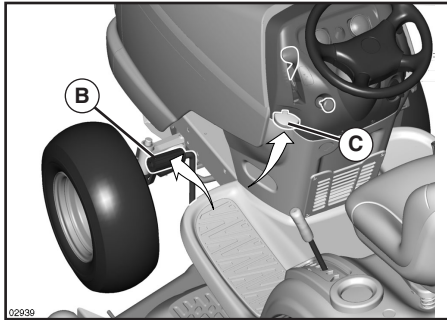

FIG. 5

STOPPING

MOWER BLADES -

- To stop mower blades, move attachment clutch lever to disengaged position (⚙).

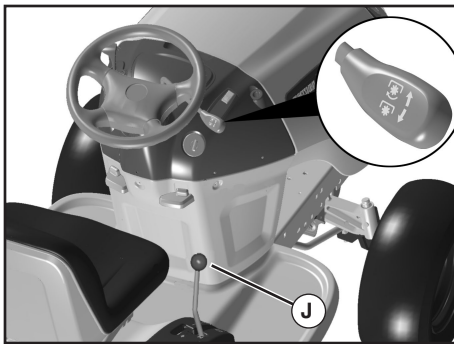

FIG. 6

(⚙) Attachment Clutch Engage Position (⚙) Disengaged Position

GROUND DRIVE -

- To stop ground drive, depress clutch/brake pedal all the way down.
- Move motion control lever (J) to neutral position.

ENGINE -

- Move throttle control (D) between half and full speed (fast) position.

NOTE: Failure to move throttle control between half and full speed (fast) position, before stopping, may cause engine to “backfire”.

- Turn ignition key (F) to “STOP” position and remove key. Always remove key when leaving tractor to prevent unauthorized use.
- Never use choke to stop engine.

IMPORTANT: Leaving the ignition switch in any position other than “STOP” will cause the battery to discharge and go dead.

NOTE: Under certain conditions when tractor is standing idle with the engine running, hot engine exhaust gases may cause “browning” of grass. To eliminate this possibility, always stop engine when stopping tractor on grass areas.



CAUTION: Always stop tractor completely, as described above, before leaving the operator's position.

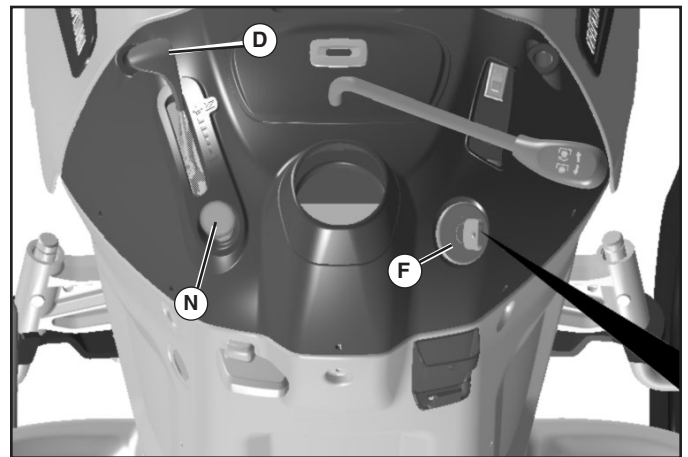

FIG. 7

TO USE THROTTLE CONTROL - D (See Fig. 7)

Always operate engine at full speed (fast).

- Operating engine at less than full speed (fast) reduces engines operating efficiency.
- Full speed (fast) offers the best bagging and mower performance.

TO USE CHOKE CONTROL - N (See Fig. 7)

Use choke control whenever you are starting a cold engine. Do not use to start a warm engine.

- To engage choke control, pull knob out. Slowly push knob in to disengage.

OPERATION

TO MOVE FORWARD AND BACKWARD (See Fig. 8)

The direction and speed of movement is controlled by the motion control lever. (J)

- Start tractor with motion control lever in neutral (N) position.
- Release parking brake.
- Slowly move motion control lever to desired position.

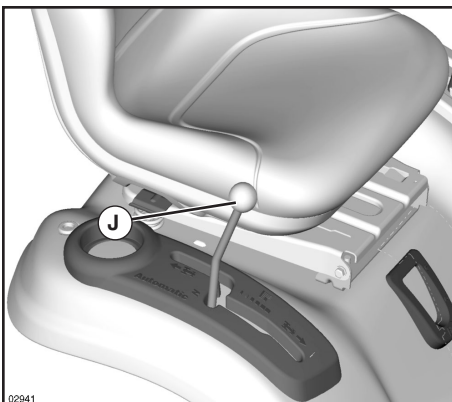

FIG. 8

TO ADJUST MOWER CUTTING HEIGHT (See Fig. 9)

The position of the attachment lift lever (A) determines the cutting height.

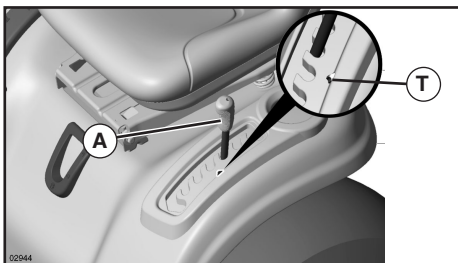

FIG. 9

- Put attachment lift lever in desired cutting height slot.
- Slide pointer tab (T) to desired cutting height as a reminder for next time you mow.

The cutting height range is approximately 1" to 4". The heights are measured from the ground to the blade tip with the engine not running. These heights are approximate and may vary depending upon soil conditions, height of grass and types of grass being mowed.

- The average lawn should be cut to approximately 2-1/2 inches during the cool season and to over 3 inches during hot months. For healthier and better looking lawns, mow often and after moderate growth.
- For best cutting performance, grass over 6 inches in height should be mowed twice. Make the first cut relatively high; the second to desired height.

TO ADJUST GAUGE WHEELS (See Fig. 10)

Gauge wheels are properly adjusted when they are slightly off the ground when mower is at the desired cutting height in operating position. Gauge wheels then keep the deck in proper position to help prevent scalping in most terrain conditions.

NOTE: Adjust gauge wheels with tractor on a flat level surface.

- Adjust mower to desired cutting height (See "TO ADJUST MOWER CUTTING HEIGHT" in this section of manual).
- With mower in desired height of cut position, gauge wheels should be assembled so they are slightly off the ground. Install gauge wheel in appropriate hole. Tighten securely.
- Repeat for all, installing gauge wheel in same adjustment hole.

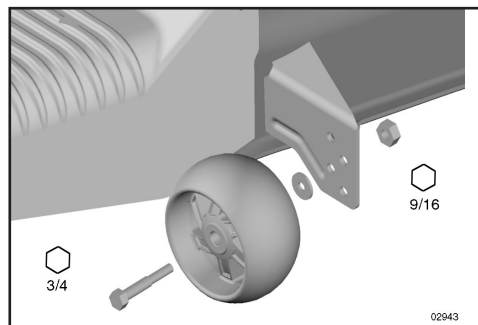

FIG. 10

TO OPERATE MOWER

Your tractor is equipped with an operator presence sensing switch. Any attempt by the operator to leave the seat with the engine running and the attachment clutch engaged will shut off the engine. You must remain fully and centrally positioned in the seat to prevent the engine from hesitating or cutting off when operating your equipment on rough, rolling terrain or hills.

- Select desired height of cut with attachment lift lever.
- Start mower blades by engaging attachment clutch control.

TO STOP MOWER BLADES - disengage attachment clutch control.



CAUTION: Do not operate the mower without either the entire grass catcher, on mowers so equipped, or the deflector shield (S) in place.

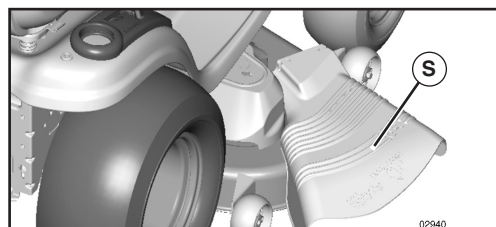

FIG. 11

OPERATION

REVERSE OPERATION SYSTEM (ROS)

Your tractor is equipped with a Reverse Operation System (ROS). Any attempt by the operator to travel in the reverse direction with the attachment clutch engaged will shut off the engine unless ignition key is placed in the ROS "ON" position.

⚠WARNING: Backing up with the attachment clutch engaged while mowing is strongly discouraged. Turning the ROS "ON", to allow reverse operation with the attachment clutch engaged, should only be done when the operator decides it is necessary to reposition the machine with the attachment engaged. **Do not mow in reverse unless absolutely necessary.**

USING THE REVERSE OPERATION SYSTEM -

Only use if you are certain no children or other bystanders will enter the mowing area.

- Move motion control lever to neutral (N) position.
- With engine running, turn ignition key counterclockwise to ROS "ON" position.
- Look down and behind before and while backing.
- Slowly move motion control lever to reverse (R) position to start movement.
- When use of the ROS is no longer needed, turn the ignition key clockwise to engine "ON" position.

ROS "ON" POSITION



ENGINE "ON" POSITION
(NORMAL OPERATING)



TO OPERATE ON HILLS



CAUTION: Do not drive up or down hills with slopes greater than 15° and do not drive across any slope.

- Choose the slowest speed before starting up or down hills.
- Avoid stopping or changing speed on hills.
- If stopping is absolutely necessary, push clutch/brake pedal quickly to brake position and engage parking brake.
- Move motion control lever to neutral (N) position.

IMPORTANT: THE MOTION CONTROL LEVER DOES NOT RETURN TO NEUTRAL (N) POSITION WHEN THE CLUTCH/BRAKE PEDAL IS DEPRESSED.

- To restart movement, slowly release parking brake and clutch/brake pedal.
- Slowly move motion control lever to slowest setting.
- Make all turns slowly.

TO TRANSPORT (See Figs. 4 and 12)

When pushing or towing your tractor, be sure to disengage transmission by placing freewheel control in freewheeling position. Free wheel control is located at the rear drawbar of tractor.

- Raise attachment lift to highest position with attachment lift control.
- Pull freewheel control out and down into the slot and release so it is held in the disengaged position.
- Do not push or tow tractor at more than two (2) MPH.
- To reengage transmission, reverse above procedure.

NOTE: To protect hood from damage when transporting your tractor on a truck or a trailer, be sure hood is closed and secured to tractor. Use an appropriate means of tying hood to tractor (rope, cord, etc.).

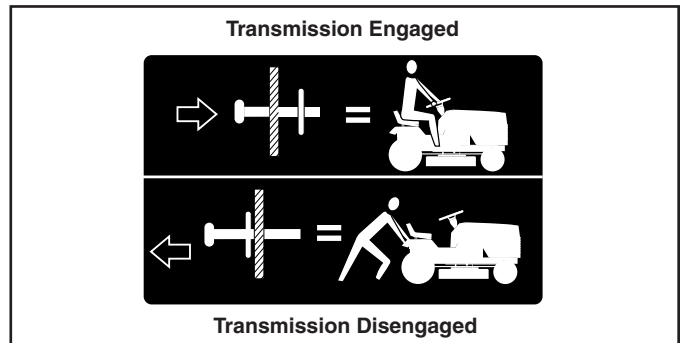

FIG. 12

SERVICE REMINDER/HOUR METER

Service reminder shows the total number of hours the engine has run and flashes to indicate that the engine or mower needs servicing. When service is required, the service reminder will flash for two hours. To service engine and mower, see the Maintenance section of this manual.

NOTE: Service reminder runs when the ignition key is in any position but "STOP". For accurate reading, be sure key remains in the "STOP" position when engine is not running.

TOWING CARTS AND OTHER ATTACHMENTS

Tow only the attachments that are recommended by and comply with specifications of the manufacturer of your tractor. Use common sense when towing. Too heavy of a load, while on a slope, is dangerous. Tires can lose traction with the ground and cause you to lose control of your tractor.

BEFORE STARTING THE ENGINE

CHECK ENGINE OIL LEVEL

The engine in your tractor has been shipped, from the factory, already filled with summer weight oil.

- Check engine oil with tractor on level ground.
- Remove oil fill cap/dipstick and wipe clean, reinsert the dipstick and screw cap tight, wait for a few seconds, remove and read oil level. If necessary, add oil until "FULL" mark on dipstick is reached. Do not overfill.
- For cold weather operation you should change oil for easier starting (See "OIL VISCOSITY CHART" in the Maintenance section of this manual).
- To change engine oil, see the Maintenance section in this manual.

OPERATION

ADD GASOLINE

- Fill fuel tank to bottom of filler neck. Do not overfill. Use fresh, clean, regular unleaded gasoline with a minimum of 87 octane. (Use of leaded gasoline will increase carbon and lead oxide deposits and reduce valve life). Do not mix oil with gasoline. Purchase fuel in quantities that can be used within 30 days to assure fuel freshness.



CAUTION: Wipe off any spilled oil or fuel. Do not store, spill or use gasoline near an open flame.

IMPORTANT: WHEN OPERATING IN TEMPERATURES BELOW 32°F (0°C), USE FRESH, CLEAN WINTER GRADE GASOLINE TO HELP INSURE GOOD COLD WEATHER STARTING.

CAUTION: Alcohol blended fuels (called gasohol or using ethanol or methanol) can attract moisture which leads to separation and formation of acids during storage. Acidic gas can damage the fuel system of an engine while in storage. To avoid engine problems, the fuel system should be emptied before storage of 30 days or longer. Drain the gas tank, start the engine and let it run until the fuel lines and carburetor are empty. Use fresh fuel next season. See Storage Instructions for additional information. Never use engine or carburetor cleaner products in the fuel tank or permanent damage may occur.

TO START ENGINE (See Fig. 4)

When starting the engine for the first time or if the engine has run out of fuel, it will take extra cranking time to move fuel from the tank to the engine.

- Be sure freewheel control is in the transmission engaged position.
- Sit on seat in operating position, depress clutch/brake pedal and set parking brake.
- Place motion control lever in neutral (N) position.
- Move attachment clutch to "DISENGAGED" position.
- Move throttle control to fast position
- Pull choke control out for a cold engine start attempt. For a warm engine start attempt the choke control may not be needed.

NOTE: Before starting, read the warm and cold starting procedures below.

- Insert key into ignition and turn key clockwise to "START" position and release key as soon as engine starts. Do not run starter continuously for more than fifteen seconds per minute. If the engine does not start after several attempts, push choke control in, wait a few minutes and try again. If engine still does not start, pull the choke control out and retry.

WARM WEATHER STARTING (50° F and above)

- When engine starts, slowly push choke control in until the engine begins to run smoothly. If the engine starts to run roughly, pull the choke control out slightly for a few seconds and then continue to push the control in

slowly.

- The attachments and ground drive can now be used. If the engine does not accept the load, restart the engine and allow it to warm up for one minute using the choke as described above.

COLD WEATHER STARTING (50° F and below)

- When engine starts, slowly push choke control in until the engine begins to run smoothly. Continue to push the choke control in small steps allowing the engine to accept small changes in speed and load, until the choke control is fully in. If the engine starts to run roughly, pull the choke control out slightly for a few seconds and then continue to push the control in slowly. This may require an engine warm-up period from several seconds to several minutes, depending on the temperature.

AUTOMATIC TRANSMISSION WARM UP

- Before driving the unit in cold weather, the transmission should be warmed up as follows:
 - Be sure the tractor is on level ground.
 - Place the motion control lever in neutral. Release the parking brake and let the clutch/brake slowly return to operating position.
 - Allow one minute for transmission to warm up. This can be done during the engine warm up period.
- The attachments can be used during the engine warm-up period after the transmission has been warmed up and may require the choke control be pulled out slightly.

NOTE: If at a high altitude (above 3000 feet) or in cold temperatures (below 32 F) the carburetor fuel mixture may need to be adjusted for best engine performance. See "TO ADJUST CARBURETOR" in the Service and Adjustments section of this manual.

PURGE TRANSMISSION



CAUTION: Never engage or disengage freewheel lever while the engine is running.

To ensure proper operation and performance, it is recommended that the transmission be purged before operating tractor for the first time. This procedure will remove any trapped air inside the transmission which may have developed during shipping of your tractor.

IMPORTANT: SHOULD YOUR TRANSMISSION REQUIRE REMOVAL FOR SERVICE OR REPLACEMENT, IT SHOULD BE PURGED AFTER REINSTALLATION BEFORE OPERATING THE TRACTOR.

- Place tractor safely on a level surface - that is clear and open - with engine off and parking brake set.
- Disengage transmission by placing freewheel control in freewheeling position (See "TO TRANSPORT" in this section of manual).
- Sitting in the tractor seat, start engine. After the engine is running, move throttle control to slow position. With motion control lever in neutral (N) position, slowly disengage clutch/brake pedal.

OPERATION



CAUTION: At any time, during step 4, there may be movement of the drive wheels.

- Move motion control lever to full forward position and hold for five (5) seconds. Move lever to full reverse position and hold for five (5) seconds. Repeat this procedure three (3) times.
- Move motion control lever to neutral (N) position. Shut-off engine and set parking brake.
- Engage transmission by placing freewheel control in engaged position (See "TO TRANSPORT" in this section of manual).
- Sitting in the tractor seat, start engine. After the engine is running, move throttle control to half (1/2) speed. With motion control lever in neutral (N) position, slowly disengage clutch/brake pedal.
- Slowly move motion control lever forward, after the tractor moves approximately five (5) feet, slowly move motion control lever to reverse position. After the tractor moves approximately five (5) feet return the motion control lever to the neutral (N) position. Repeat this procedure with the motion control lever three (3) times.

Your transmission is now purged and now ready for normal operation.

MOWING TIPS

- Mower should be properly leveled for best mowing performance. See "TO LEVEL MOWER HOUSING" in the Service and Adjustments section of this manual.
- The left hand side of mower should be used for trimming.
- Drive so that clippings are discharged onto the area that has been cut. Have the cut area to the right of the machine. This will result in a more even distribution of clippings and more uniform cutting.
- When mowing large areas, start by turning to the right so that clippings will discharge away from shrubs, fences, driveways, etc. After one or two rounds, mow in the opposite direction making left hand turns until finished (See Fig. 13).

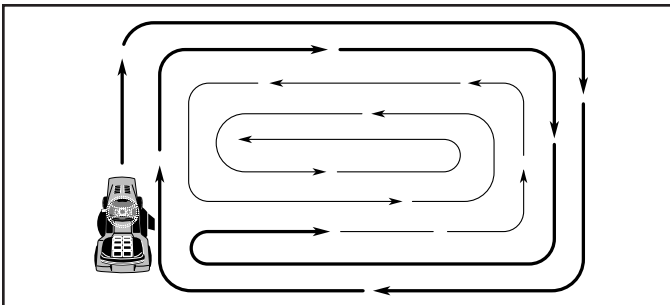

FIG. 13

- If grass is extremely tall, it should be mowed twice to reduce load and possible fire hazard from dried clippings. Make first cut relatively high; the second to the desired height.
- Do not mow grass when it is wet. Wet grass will plug mower and leave undesirable clumps. Allow grass to dry before mowing.
- **Always operate engine at full throttle when mowing** to assure better mowing performance and proper discharge of material. Regulate ground speed by selecting a low enough gear to give the mower cutting performance as well as the quality of cut desired.
- When operating attachments, select a ground speed that will suit the terrain and give best performance of the attachment being used.

MULCHING MOWING TIPS

IMPORTANT: FOR BEST PERFORMANCE, KEEP MOWER HOUSING FREE OF BUILT-UP GRASS AND TRASH. CLEAN AFTER EACH USE.

- The special mulching blade will recut the grass clippings many times and reduce them in size so that as they fall onto the lawn they will disperse into the grass and not be noticed. Also, the mulched grass will biodegrade quickly to provide nutrients for the lawn. Always mulch with your highest engine (blade) speed as this will provide the best recutting action of the blades.
- Avoid cutting your lawn when it is wet. Wet grass tends to form clumps and interferes with the mulching action. The best time to mow your lawn is the early afternoon. At this time the grass has dried, yet the newly cut area will not be exposed to direct sunlight.
- For best results, adjust the mower cutting height so that the mower cuts off only the top one-third of the grass blades (See Fig. 14). For extremely heavy mulching, reduce your width of cut on each pass and mow slowly.

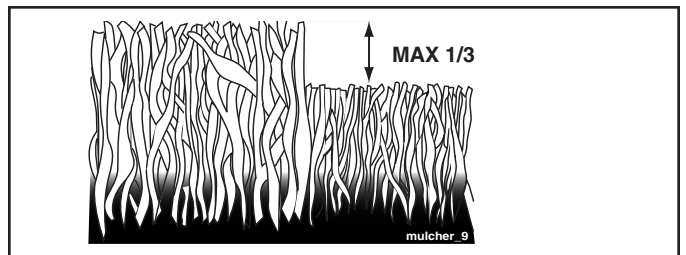

FIG. 14

- Certain types of grass and grass conditions may require that an area be mulched a second time to completely hide the clippings. When doing a second cut, mow across (perpendicular) to the first cut path.
- Change your cutting pattern from week to week. Mow north to south one week then change to east to west the next week. This will help prevent matting and graining of the lawn.

MAINTENANCE

MAINTENANCE SCHEDULE		BEFORE EACH USE	EVERY 8 HOURS	EVERY 25 HOURS	EVERY 50 HOURS	EVERY 100 HOURS	EVERY SEASON	BEFORE STORAGE
TRACTOR	Check Brake Operation	✓	✓					
	Check Tire Pressure	✓	✓					
	Check Operator Presence & ROS Systems	✓						
	Check for Loose Fasteners	✓				✓		✓
	Check/Replace Mower Blades			✓ ₃				
	Lubrication Chart			✓				✓
	Check Battery Level			✓ ₄				
	Clean Battery and Terminals			✓				✓
	Check Transaxle Cooling			✓				
	Check Mower Levelness				✓			
	Check V-Belts					✓		
ENGINE	Check Engine Oil Level	✓	✓					
	Change Engine Oil (with oil filter)				✓ _{1,2}			✓
	Change Engine Oil (without oil filter)			✓ _{1,2}				✓
	Clean Air Filter			✓ ₂				
	Clean Air Screen			✓ ₂				
	Inspect Muffler/Spark Arrester				✓			
	Replace Oil Filter (If equipped)					✓ _{1,2}		
	Clean Engine Cooling Fins					✓ ₂		
	Replace Spark Plug					✓	✓	
	Replace Air Filter Paper Cartridge					✓ ₂		
	Replace Fuel Filter						✓	

- 1 - Change more often when operating under a heavy load or in high ambient temperatures.
 2 - Service more often when operating in dirty or dusty conditions.

- 3 - Replace blades more often when mowing in sandy soil.
 4 - Not required if equipped with maintenance-free battery.

maint_sch-tractor.ROS.e

GENERAL RECOMMENDATIONS

The warranty on this tractor does not cover items that have been subjected to operator abuse or negligence. To receive full value from the warranty, operator must maintain tractor as instructed in this manual.

Some adjustments will need to be made periodically to properly maintain your tractor.

At least once a season, check to see if you should make any of the adjustments described in the Service and Adjustments section of this manual.

- At least once a year you should replace the spark plug, clean or replace air filter, and check blades and belts for wear. A new spark plug and clean air filter assure proper air-fuel mixture and help your engine run better and last longer.

BEFORE EACH USE

- Check engine oil level.
- Check brake operation.
- Check tire pressure.
- Check operator presence and ROS systems for proper operation.
- Check for loose fasteners.

LUBRICATION CHART

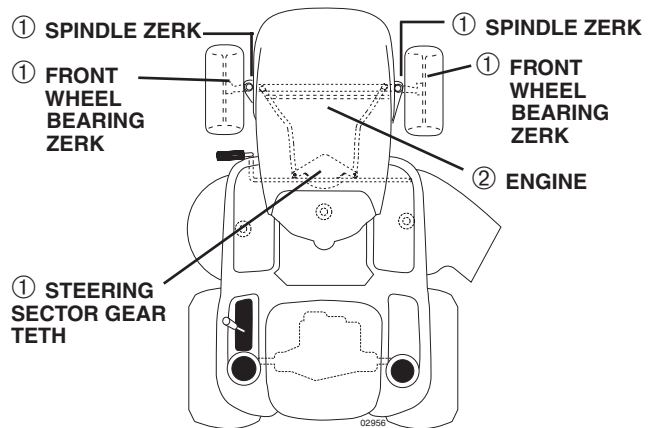

- ① General Purpose Grease
 ② Refer to Maintenance "ENGINE" Section

IMPORTANT: DO NOT OIL OR GREASE THE PIVOT POINTS WHICH HAVE SPECIAL NYLON BEARINGS. VISCOUS LUBRICANTS WILL ATTRACT DUST AND DIRT THAT WILL SHORTEN THE LIFE OF THE SELF-LUBRICATING BEARINGS. IF YOU FEEL THEY MUST BE LUBRICATED, USE ONLY A DRY, POWDERED GRAPHITE TYPE LUBRICANT SPARINGLY.

MAINTENANCE

TRACTOR

Always observe safety rules when performing any maintenance.

BRAKE OPERATION

If tractor requires more than five (5) feet to stop at highest speed in highest gear on a level, dry concrete or paved surface, then brake must be serviced. (See "TO CHECK BRAKE" in the Service and Adjustments section of this manual).

TIRES

- Maintain proper air pressure in all tires (See PSI on tires).
- Keep tires free of gasoline, oil, or insect control chemicals which can harm rubber.
- Avoid stumps, stones, deep ruts, sharp objects and other hazards that may cause tire damage.

NOTE: To seal tire punctures and prevent flat tires due to slow leaks, tire sealant may be purchased from your local parts dealer. Tire sealant also prevents tire dry rot and corrosion.

OPERATOR PRESENCE SYSTEM AND REVERSE OPERATION SYSTEM (ROS)

Be sure operator presence and reverse operation systems are working properly. If your tractor does not function as described, repair the problem immediately.

- The engine should not start unless the brake pedal is fully depressed, and the attachment clutch control is in the disengaged position.

CHECK OPERATOR PRESENCE SYSTEM

- When the engine is running, any attempt by the operator to leave the seat without first setting the parking brake should shut off the engine.
- When the engine is running and the attachment clutch is engaged, any attempt by the operator to leave the seat should shut off the engine.
- The attachment clutch should never operate unless the operator is in the seat.

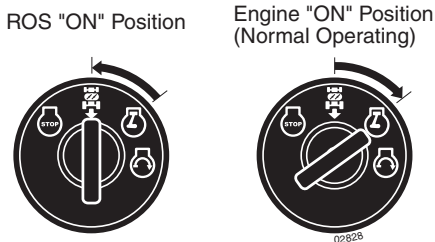

CHECK REVERSE OPERATION (ROS) SYSTEM

- When the engine is running with the ignition switch in the engine "ON" position and the attachment clutch engaged, any attempt by the operator to shift into reverse should shut off the engine.
- When the engine is running with the ignition switch in the ROS "ON" position and the attachment clutch engaged, any attempt by the operator to shift into reverse should NOT shut off the engine.

BLADE CARE

For best results mower blades must be sharp. Replace worn, bent or damaged blades.



CAUTION: Use only a replacement blade approved by the manufacturer of your tractor. Using a blade not approved by the manufacturer of your tractor is hazardous, could damage your tractor and void your warranty.

BLADE REMOVAL (See Fig. 15)

- Raise mower to highest position to allow access to blades.

NOTE: Protect your hands with gloves and/or wrap blade with heavy cloth.

- Remove blade bolt by turning counterclockwise.
- Install new blade with stamped "GRASS SIDE" facing the ground.

IMPORTANT: To ensure proper assembly, center hole in blade must align with star on mandrel assembly.

- Install and tighten blade bolt securely (45-55 Ft. Lbs. torque).

IMPORTANT: Special blade bolt is heat treated.

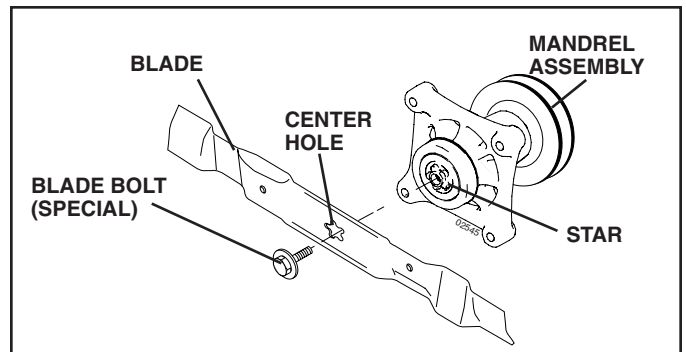

FIG. 15

BATTERY

Your tractor has a battery charging system which is sufficient for normal use. However, periodic charging of the battery with an automotive charger will extend its life.

- Keep battery and terminals clean.
- Keep battery bolts tight.
- Keep small vent holes open.
- Recharge at 6-10 amperes for 1 hour.

NOTE: The original equipment battery on your tractor is maintenance free. Do not attempt to open or remove caps or covers. Adding or checking level of electrolyte is not necessary.

TO CLEAN BATTERY AND TERMINALS

Corrosion and dirt on the battery and terminals can cause the battery to "leak" power.

- Remove terminal guard.
- Disconnect BLACK battery cable first then RED battery cable and remove battery from tractor.

MAINTENANCE

- Rinse the battery with plain water and dry.
- Clean terminals and battery cable ends with wire brush until bright.
- Coat terminals with grease or petroleum jelly.
- Reinstall battery (See "CONNECT BATTERY" in the Assembly section of this manual).

V-BELTS

Check V-belts for deterioration and wear after 100 hours of operation and replace if necessary. The belts are not adjustable. Replace belts if they begin to slip from wear.

TRANSAXLE COOLING

The transmission fan and cooling fins should be kept clean to assure proper cooling.

Do not attempt to clean fan or transmission while engine is running or while the transmission is hot. To prevent possible damage to seals, do not use high pressure water or steam to clean transaxle.

- Inspect cooling fan to be sure fan blades are intact and clean.
- Inspect cooling fins for dirt, grass clippings and other materials. To prevent damage to seals, do not use compressed air or high pressure sprayer to clean cooling fins.

TRANSAXLE PUMP FLUID

The transaxle was sealed at the factory and fluid maintenance is not required for the life of the transaxle. Should the transaxle ever leak or require servicing, contact your nearest authorized service center/department.

ENGINE

LUBRICATION

Only use high quality detergent oil rated with API service classification SG-SL. Select the oil's SAE viscosity grade according to your expected operating temperature. When operating in temperatures below 0° F (-18° C) synthetic oil must be used.

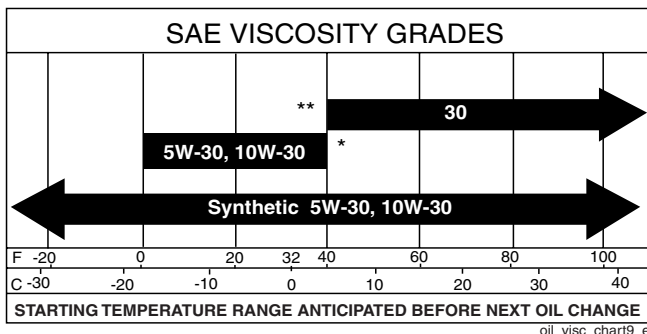

FIG. 16

*** CAUTION:** Air cooled engines run hotter than automotive engines. The use of non-synthetic multi-viscosity oils (5W30, 10W30 etc.) in temperatures above 40° F (4° C) will result in higher than normal oil consumption. When using a multi-viscosity oil, check oil level more frequently.

**** CAUTION:** SAE 30 oil, if used below 40° F (4° C), will result in hard starting and possible engine bore damage due to inadequate lubrication.



NOTE: Synthetic oil meeting ILSAC GF-2, API certification mark and API service symbol (shown at left) with "SJ/CF ENERGY CONSERVING" or higher, is an acceptable oil at all temperatures. **Use of synthetic oil does not alter required oil change intervals.**

Change the oil after every 50 hours of operation or at least once a year if the tractor is not used for 50 hours in one year.

Check the crankcase oil level before starting the engine and after each eight (8) hours of operation. Tighten oil fill cap/dipstick securely each time you check the oil level.

TO CHANGE ENGINE OIL (See Figs. 16 and 17)

Determine temperature range expected before oil change. All oil must meet API service classification SG-SL.

- Be sure tractor is on level surface.
- Oil will drain more freely when warm.
- Catch oil in a suitable container.
- Remove oil fill cap/dipstick. Be careful not to allow dirt to enter the engine when changing oil.
- Remove yellow cap from end of drain valve and install the drain tube onto the fitting.

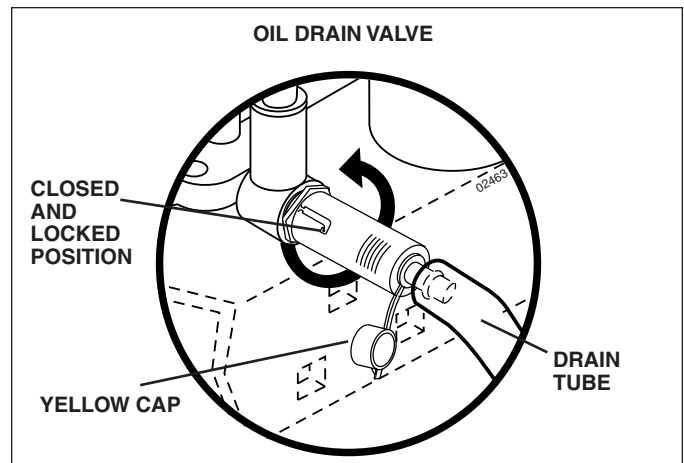

FIG. 17

- Unlock drain valve by pushing inward and turning counterclockwise.
- To open, pull out on the drain valve.
- After oil has drained completely, close and lock the drain valve by pushing inward and turning clockwise until the pin is in the locked position as shown.
- Remove the drain tube and replace the cap onto to the bottom fitting of the drain valve.
- Refill engine with oil through oil fill dipstick tube. Pour slowly. Do not overfill. For approximate capacity see "PRODUCT SPECIFICATIONS" section of this manual.
- Use gauge on oil fill cap/dipstick for checking level. Be sure dipstick cap is tightened securely for accurate reading. Keep oil at "FULL" line on dipstick. Tighten cap onto the tube securely when finished.

MAINTENANCE

CLEAN AIR SCREEN

Air screen must be kept free of dirt and chaff to prevent engine damage from overheating. Clean with a wire brush or compressed air to remove dirt and stubborn dried gum fibers.

AIR FILTER (See Fig. 18)

Your engine will not run properly using a dirty air filter. Clean the foam pre-cleaner after every 25 hours of operation or every season. Service paper cartridge every 100 hours of operation or every season, whichever occurs first.

Service air cleaner more often under dusty conditions.

- Remove cover.

TO SERVICE PRE-CLEANER

- Wash it in liquid detergent and water.
- Squeeze it dry in a clean cloth.
- Saturate it in engine oil. Wrap it in clean, absorbent cloth and squeeze to remove excess oil.
- If very dirty or damaged, replace pre-cleaner.

TO SERVICE CARTRIDGE

- Clean cartridge by tapping gently on flat surface. If very dirty or damaged, replace cartridge.
- Reinstall pre-cleaner cartridge, cover and secure.

IMPORTANT: PETROLEUM SOLVENTS, SUCH AS KEROSENE, ARE NOT TO BE USED TO CLEAN THE CARTRIDGE. THEY MAY CAUSE DETERIORATION OF THE CARTRIDGE. DO NOT OIL CARTRIDGE. DO NOT USE PRESSURIZED AIR TO CLEAN OR DRY CARTRIDGE.

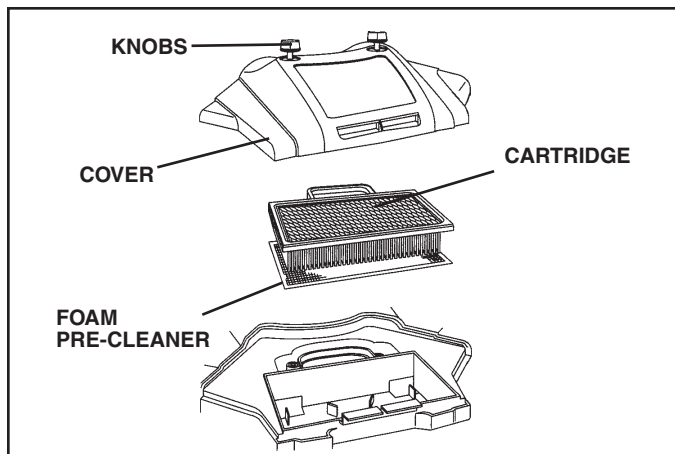

FIG. 18

ENGINE OIL FILTER

Replace the engine oil filter every season or every other oil change if the tractor is used more than 100 hours in one year.

CLEAN AIR INTAKE/COOLING AREAS

To insure proper cooling, make sure the grass screen, cooling fins, and other external surfaces of the engine are kept clean at all times.

Every 100 hours of operation (more often under extremely dusty, dirty conditions), remove the blower housing and other cooling shrouds. Clean the cooling fins and external surfaces as necessary. Make sure the cooling shrouds are reinstalled.

NOTE: Operating the engine with a blocked grass screen, dirty or plugged cooling fins, and/or cooling shrouds removed will cause engine damage due to overheating.

MUFFLER

Inspect and replace corroded muffler and spark arrester (if equipped) as it could create a fire hazard and/or damage.

SPARK PLUGS

Replace spark plugs at the beginning of each mowing season or after every 100 hours of operation, whichever occurs first. Spark plug type and gap setting are shown in "PRODUCT SPECIFICATIONS" section of this manual.

IN-LINE FUEL FILTER (See Fig. 19)

The fuel filter should be replaced once each season. If fuel filter becomes clogged, obstructing fuel flow to carburetor, replacement is required.

- With engine cool, remove filter and plug fuel line sections.
- Place new fuel filter in position in fuel line with arrow pointing towards carburetor.
- Be sure there are no fuel line leaks and clamps are properly positioned.
- Immediately wipe up any spilled gasoline.

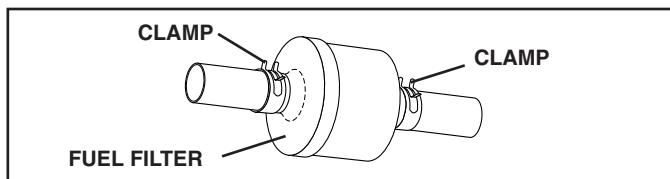

FIG. 19

CLEANING

- Clean engine, battery, seat, finish, etc. of all foreign matter.
- Keep finished surfaces and wheels free of all gasoline, oil, etc.
- Protect painted surfaces with automotive type wax.

We do not recommend using a garden hose or pressure washer to clean your tractor unless the engine and transmission are covered to keep water out. Water in engine or transmission will shorten the useful life of your tractor. Use compressed air or a leaf blower to remove grass, leaves and trash from tractor and mower.

SERVICE AND ADJUSTMENTS



WARNING: TO AVOID SERIOUS INJURY, BEFORE PERFORMING ANY SERVICE OR ADJUSTMENTS:

- Depress clutch/brake pedal fully and set parking brake.
- Place motion control lever in neutral (N) position.
- Place attachment clutch in “DISENGAGED” position.
- Turn ignition key to “STOP” and remove key.
- Make sure the blades and all moving parts have completely stopped.
- Disconnect spark plug wire from spark plug and place wire where it cannot come in contact with plug.

TRACTOR

TO REMOVE MOWER (See Fig. 20)

- Place attachment clutch in “DISENGAGED” position.
- Lower attachment lift lever to its lowest position.
- Roll belt off engine pulley (M).
- Remove retainer spring (K), slide collar (L) off and push housing guide (P) out of bracket.
- Remove clutch cable spring (Q) from idler arm (R).
- Disconnect front link (E) from mower - remove retainer spring and washer.
- Go to either side of mower and disconnect mower suspension arm (A) from chassis pin (B) and rear lift link (C) from rear mower bracket (D) - remove retainer springs and washers.
- Go to other side of mower and disconnect the suspension arm and rear lift link.



CAUTION: After rear lift links are disconnected, the attachment lift lever will be spring loaded. Have a tight grip on lift lever when changing position of the lever.

- Slide mower out from under right side of tractor.

IMPORTANT: If an attachment other than the mower deck is to be mounted on the tractor, remove the front link (E) and rear lift links (C) from tractor.

TO INSTALL MOWER (See Figs. 21-24)

Be sure tractor is on level surface and engage parking brake.

- Lower attachment lift lever to its lowest position.



CAUTION: Lift lever is spring loaded. Have a tight grip on lift lever, lower it slowly and engage in lowest position.

NOTE: Be sure mower side suspension arms (A) are pointing forward before sliding mower under tractor.

- Slide mower under tractor until it is centered under tractor.
- ATTACH MOWER SIDE SUSPENSION ARMS (A) TO CHASSIS - Position hole in arm over pin (B) on outside of tractor chassis and secure with washer and retainer spring.
- Repeat on opposite side of tractor.

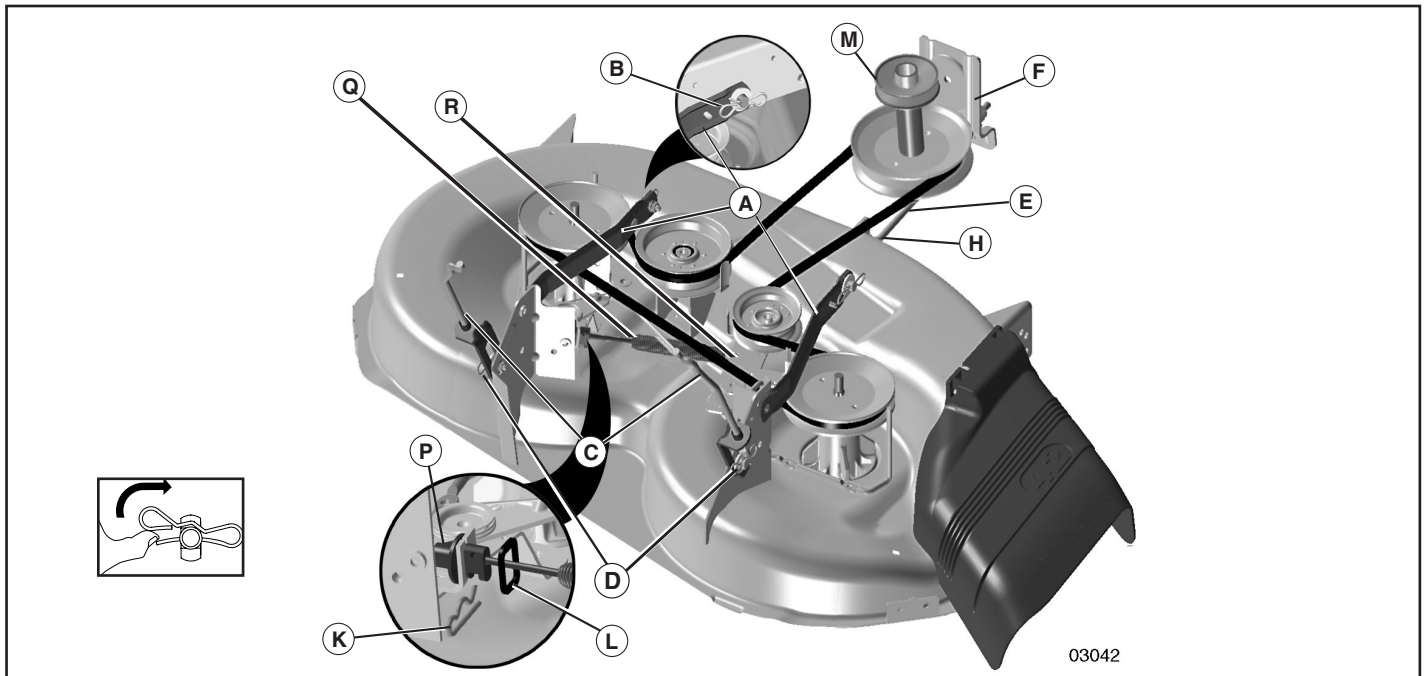

FIG. 20

SERVICE AND ADJUSTMENTS

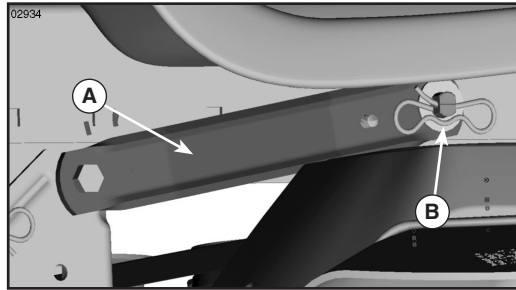

FIG. 21

- ATTACH REAR LIFT LINKS (C) - Lift rear corner of mower and position slot in link assembly over pin on rear mower bracket (D) and secure with washer and retainer spring.
- Repeat on opposite side of tractor.

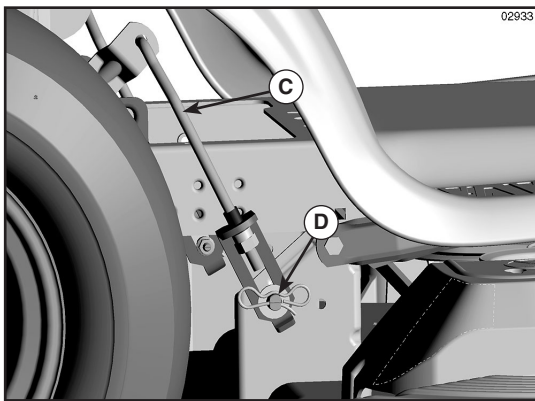

FIG. 22

- ATTACH FRONT LINK (E) - Work from left side of tractor. Insert rod end of link assembly through front hole in tractor front suspension bracket (F).
- Insert end of link (E) into hole in front mower bracket (H) and secure with washer and retainer spring (J).

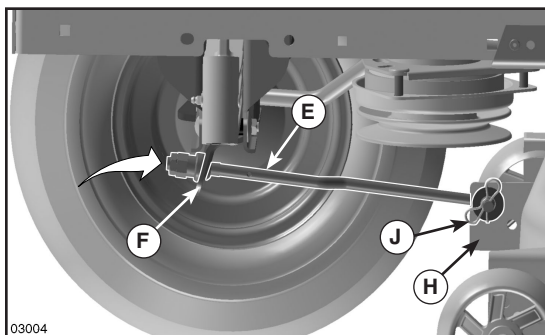

FIG. 23

- Push clutch cable housing guide (P) into bracket, slide collar (L) onto guide and secure with retainer spring (K).
- Hook end of clutch cable spring (Q) into hole in idler arm (R).
- Install belt onto engine pulley (M).

IMPORTANT: Check belt for proper routing in all mower pulley grooves.

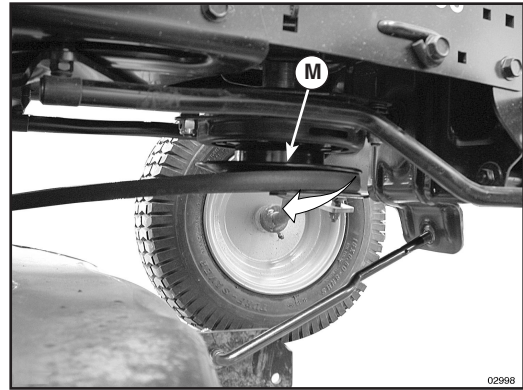

FIG. 24

- Raise attachment lift lever to highest position.
- If necessary, adjust gauge wheels before operating mower as shown in the Operation section of this manual.

TO LEVEL MOWER

Make sure tires are properly inflated to the PSI shown on tires. If tires are over or under inflated, it may affect the appearance of your lawn and lead you to think the mower is not adjusted properly.

VISUAL SIDE-TO-SIDE ADJUSTMENT (See Fig. 25)

- With all tires properly inflated and if your lawn appears unevenly cut, determine which side of mower is cutting lower.

NOTE: As desired, you can raise the low side of mower or lower the high side.

- Go to side of mower you wish to adjust.
- With a 3/4" or adjustable wrench, turn lift link adjustment nut (A) to the left to lower the mower, or, to the right to raise the mower.

NOTE: Each full turn of adjustment nut will change mower height about 3/16".

- Test your adjustment by mowing some uncut grass and visually checking the appearance. Readjust, if necessary, until you are satisfied with the results.

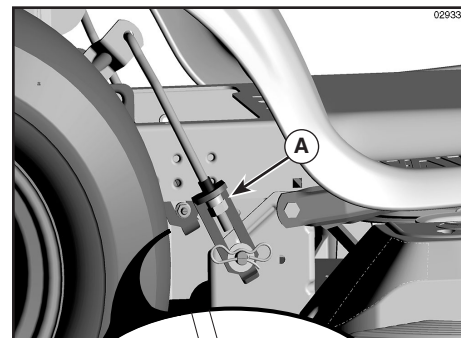

Turn nut right to raise mower
Turn nut left to lower mower

FIG. 25

SERVICE AND ADJUSTMENTS

PRECISION SIDE-TO-SIDE ADJUSTMENT

(See Fig. 26)

- With all tires properly inflated, park tractor on level ground or driveway.



CAUTION: Blades are sharp. Protect your hands with gloves and/or wrap blade with heavy cloth.

- Raise mower to its highest position.
- At both sides of mower, position blade at side and measure the distance (A) from bottom edge of blade to the ground. The distance should be the same on both sides.
- If adjustment is necessary, see steps in Visual Adjustment instructions above.
- Recheck measurements, adjust if necessary until both sides are equal.

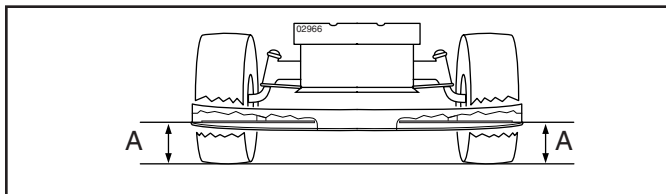

FIG. 26

FRONT-TO-BACK ADJUSTMENT (See Figs. 27 and 28)

IMPORTANT: Deck must be level side-to-side.

To obtain the best cutting results, the mower blades should be adjusted so the front tip is 1/8" to 1/2" lower than the rear tip when the mower is in its highest position.



CAUTION: Blades are sharp. Protect your hands with gloves and/or wrap blade with heavy cloth.

- Raise mower to highest position.
- Position any blade so the tip is pointing straight forward. Measure distance (B) to the ground at front and rear tip of the blade.
- If front tip of blade is not 1/8" to 1/2" lower than the rear tip, go to the front of tractor.
- With an 11/16" or adjustable wrench, loosen jam nut A several turns to clear adjustment nut B.
- With a 3/4" or adjustable wrench, turn front link adjustment nut (B) clockwise (tighten) to raise the front of mower, or, counterclockwise (loosen) to lower the front mower.

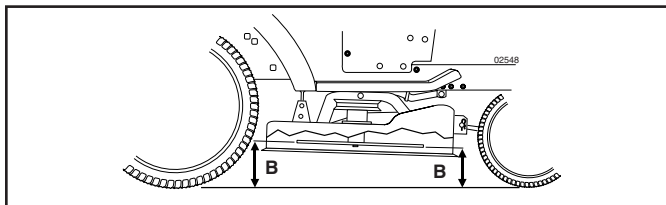
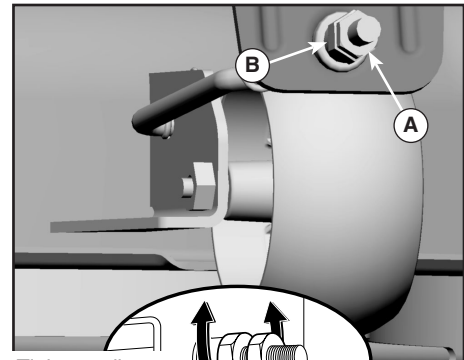

FIG. 27

NOTE: Each full turn of the adjustment nut will change mower height about 1/8".

- Recheck measurements, adjust if necessary until front tip of blade is 1/8" to 1/2" lower than the rear tip.
- Hold adjustment nut in position with wrench and tighten jam nut securely against adjustment nut.



Tighten adjust nut B to raise mower
Loosen adjust nut B to lower mower

Loosen jam nut A first

FIG. 28

TO REPLACE MOWER DRIVE BELT

(See Fig. 29)

MOWER DRIVE BELT REMOVAL

- Park tractor on a level surface. Engage parking brake.
- Lower attachment lift lever to its lowest position.
- Remove any dirt or grass clippings which may have accumulated around mandrels and entire upper deck surface.
- Remove belt from electric clutch pulley (M), both mandrel pulleys (R) and all idler pulleys (S).

MOWER DRIVE BELT INSTALLATION

- Install belt around all mandrel pulleys (R) and around idler pulleys (S) as shown.
- Install belt onto electric clutch pulley (M).

IMPORTANT: Check belt for proper routing in all mower pulley grooves.

- Raise attachment lift lever to highest position.

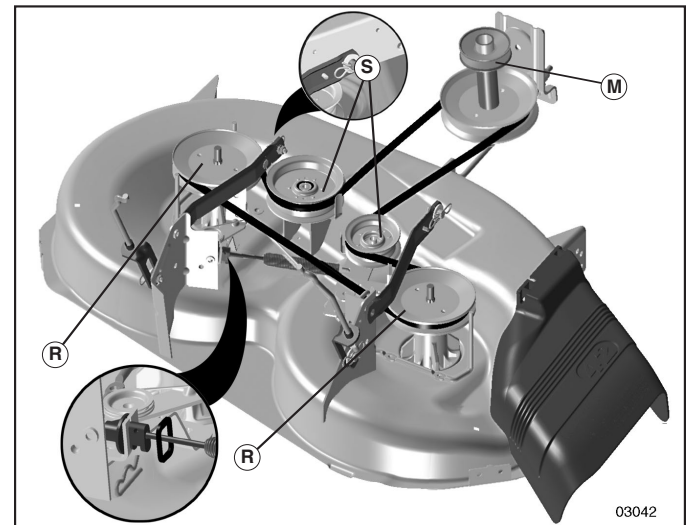

FIG. 29

TO CHECK BRAKE

If tractor requires more than five (5) feet to stop at highest speed in highest gear on a level, dry concrete or paved surface, then brake must be serviced.

SERVICE AND ADJUSTMENTS

You may also check brake by:

1. Park tractor on a level, dry concrete or paved surface, depress clutch/brake pedal all the way down and engage parking brake.
2. Disengage transmission by placing freewheel control in "transmission disengaged" position. Pull freewheel control out and into the slot and release so it is held in the disengaged position.

The rear wheels must lock and skid when you try to manually push the tractor forward. If the rear wheels rotate, then the brake needs to be serviced. Contact a Sears or other qualified service center.

TO REPLACE MOTION DRIVE BELT

(See Fig. 30)

Park the tractor on level surface. Engage parking brake. For assistance, there is a belt installation guide decal on bottom side of left footrest.

BELT REMOVAL -

- Remove mower (See "TO REMOVE MOWER" in this section of manual).

NOTE: Observe entire motion drive belt and position of all belt guides and keepers.

- Remove belt from stationary idler (A) and clutching idler (B).
- Remove belt from centerspan idler (C).
- Pull belt slack toward rear of tractor. Remove belt upwards from transaxle input pulley (D).
- Remove belt downward from engine pulley (E).
- Slide belt toward rear of tractor, off the steering plate (F) and remove from tractor.

BELT INSTALLATION -

- Install new belt from tractor rear to front, over the steering plate (F) and above clutch brake pedal shaft (G).
- Pull belt toward front of tractor and roll belt onto engine pulley (E).
- Pull belt toward rear of tractor. Carefully work belt down around transaxle input pulley (D). Be sure belt is inside the belt keeper.

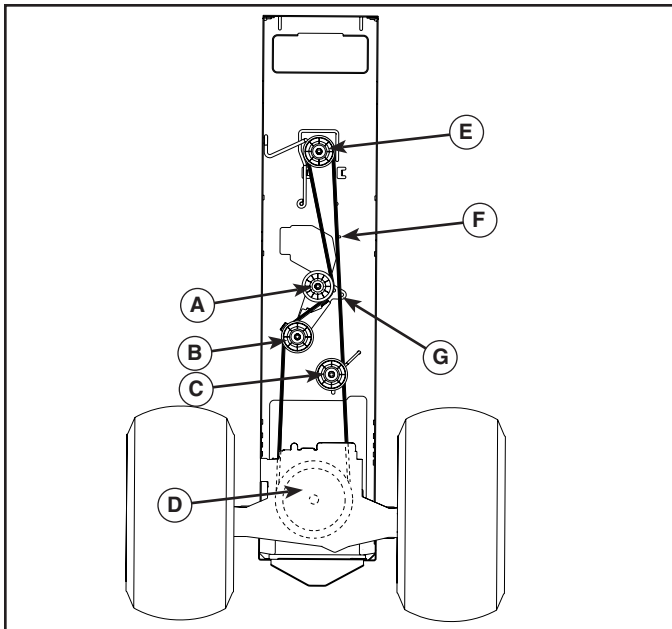

FIG. 30

- Install belt on centerspan idler (C).
- Install belt through stationary idler (A) and clutching idler (B).
- Make sure belt is in all pulley grooves and inside all belt guides and keepers.
- Install mower (See "TO INSTALL MOWER" in this section of manual).

FRONT WHEEL TOE-IN/CAMBER

Your new tractor front wheel toe-in and camber is set at the factory and is normal. The front wheel toe-in and camber are not adjustable. If damage has occurred to affect the factory set front wheel toe-in or camber, contact a qualified service center.

TO REMOVE WHEEL FOR REPAIRS

(See Fig. 31)

- Block up axle securely.
- Remove axle cover, retaining ring and washers to allow wheel removal (rear wheel contains a square key - Do not lose).
- Repair tire and reassemble.
- On rear wheels only: align grooves in rear wheel hub and axle. Insert square key.
- Replace washers and snap retaining ring securely in axle groove.
- Replace axle cover.

NOTE: To seal tire punctures and prevent flat tires due to slow leaks, tire sealant may be purchased from your local parts dealer. Tire sealant also prevents tire dry rot and corrosion.

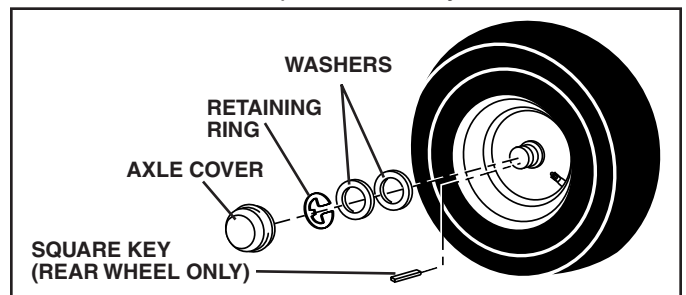

FIG. 31

TO START ENGINE WITH A WEAK BATTERY

(See Fig. 32)



WARNING: Lead-acid batteries generate explosive gases. Keep sparks, flame and smoking materials away from batteries. Always wear eye protection when around batteries.

If your battery is too weak to start the engine, it should be recharged. (See "BATTERY" in the MAINTENANCE section of this manual).

If "jumper cables" are used for emergency starting, follow this procedure:

IMPORTANT: YOUR TRACTOR IS EQUIPPED WITH A 12 VOLT SYSTEM. THE OTHER VEHICLE MUST ALSO BE A 12 VOLT SYSTEM. DO NOT USE YOUR TRACTOR BATTERY TO START OTHER VEHICLES.

TO ATTACH JUMPER CABLES -

- Connect one end of the RED cable to the POSITIVE (+) terminal of each battery(A-B), taking care not to short against tractor chassis.

SERVICE AND ADJUSTMENTS

- Connect one end of the BLACK cable to the NEGATIVE (-) terminal (C) of fully charged battery.
- Connect the other end of the BLACK cable (D) to good chassis ground, away from fuel tank and battery.

TO REMOVE CABLES, REVERSE ORDER -

- BLACK cable first from chassis and then from the fully charged battery.
- RED cable last from both batteries.

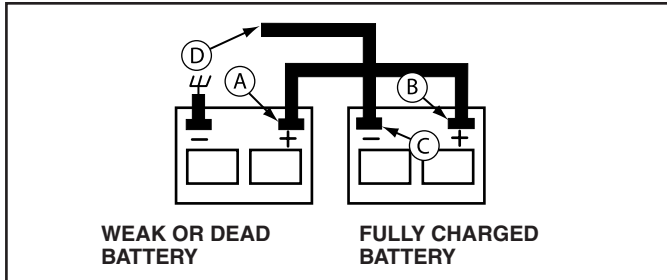

FIG. 32

TO REPLACE HEADLIGHT BULB

- Raise hood.
- Pull bulb holder out of the hole in the backside of the grill.
- Replace bulb in holder and push bulb holder securely back into the hole in the backside of the grill.
- Close hood.

INTERLOCKS AND RELAYS

Loose or damaged wiring may cause your tractor to run poorly, stop running, or prevent it from starting.

- Check wiring. See electrical wiring diagram in the Repair Parts section.

TO REPLACE FUSE

Replace with 20 amp automotive-type plug-in fuse. The fuse holder is located behind the dash.

TO REMOVE HOOD AND GRILL ASSEMBLY (See Fig. 33)

- Raise hood.
- Unsnap headlight wire connector.
- Stand in front of tractor. Grasp hood at sides, tilt toward engine and lift off of tractor.
- To replace, reverse above procedure.

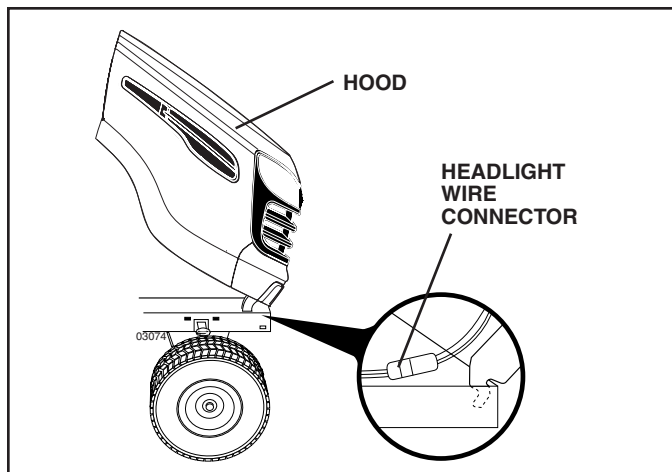

FIG. 33

ENGINE

TO ADJUST THROTTLE CONTROL CABLE (See Fig. 34)

The throttle control has been preset at the factory and adjustment should not be necessary. Check adjustment as described below before loosening cable. If adjustment is necessary, proceed as follows:

- With engine not running, move throttle control lever to fast position.
- Check that swivel is against stop. If it is not, loosen cable clamp screw and pull cable back until swivel is against stop. Tighten cable clamp screw securely.

TO ADJUST CHOKE CONTROL (See Fig. 35)

The choke control has been preset at the factory and adjustment should not be necessary. Check adjustment as described below before loosening cable. If adjustment is necessary, proceed as follows:

- With engine not running, move choke control (located on dash panel) to full choke position.
- Loosen knob and remove cover assembly from air cleaner.
- Choke should be closed. If it is not, loosen casing clamp screw and move choke cable until choke is completely closed. Tighten casing clamp screw securely.
- Replace air cleaner cover assembly and tighten knob.

TO ADJUST CARBURETOR

Your carburetor is not adjustable. If your engine does not operate properly due to suspected carburetor problems, take your tractor to an authorized service center for repair and/or adjustment.

High speed stop is factory adjusted. Do not adjust - damage may result.

IMPORTANT: NEVER TAMPER WITH THE ENGINE GOVERNOR, WHICH IS FACTORY SET FOR PROPER ENGINE SPEED. OVERSPEEDING THE ENGINE ABOVE THE FACTORY HIGH SPEED SETTING CAN BE DANGEROUS. IF YOU THINK THE ENGINE-GOVERNED HIGH SPEED NEEDS ADJUSTING, CONTACT YOUR NEAREST AUTHORIZED SERVICE CENTER/DEPARTMENT, WHICH HAS PROPER EQUIPMENT AND EXPERIENCE TO MAKE ANY NECESSARY ADJUSTMENTS.

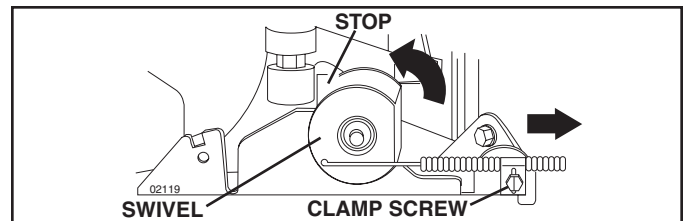

FIG. 34

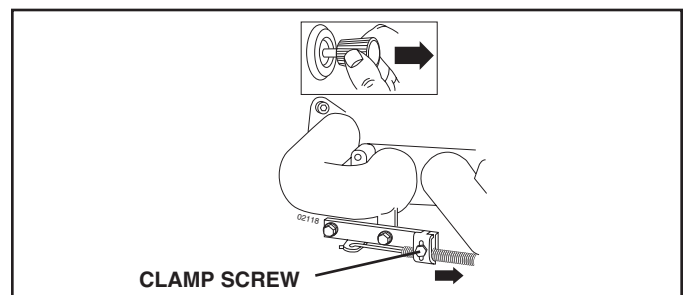

FIG. 35

STORAGE

Immediately prepare your tractor for storage at the end of the season or if the tractor will not be used for 30 days or more.



WARNING: Never store the tractor with gasoline in the tank inside a building where fumes may reach an open flame or spark. Allow the engine to cool before storing in any enclosure.

TRACTOR

Remove mower from tractor for winter storage. When mower is to be stored for a period of time, clean it thoroughly, remove all dirt, grease, leaves, etc. Store in a clean, dry area.

- Clean entire tractor (See “CLEANING” in the Maintenance section of this manual).
- Inspect and replace belts, if necessary (See belt replacement instructions in the Service and Adjustments section of this manual).
- Lubricate as shown in the Maintenance section of this manual.
- Be sure that all nuts, bolts and screws are securely fastened. Inspect moving parts for damage, breakage and wear. Replace if necessary.
- Touch up all rusted or chipped paint surfaces; sand lightly before painting.

BATTERY

- Fully charge the battery for storage.
- After a period of time in storage, battery may require recharging.
- To help prevent corrosion and power leakage during long periods of storage, battery cables should be disconnected and battery cleaned thoroughly (see “TO CLEAN BATTERY AND TERMINALS” in the Maintenance section of this manual).
- After cleaning, leave cables disconnected and place cables where they cannot come in contact with battery terminals.
- If battery is removed from tractor for storage, do not store battery directly on concrete or damp surfaces.

ENGINE

FUEL SYSTEM

IMPORTANT: IT IS IMPORTANT TO PREVENT GUM DEPOSITS FROM FORMING IN ESSENTIAL FUEL SYSTEM PARTS SUCH AS CARBURETOR, FUEL FILTER, FUEL HOSE, OR TANK DURING STORAGE. ALSO, EXPERIENCE INDICATES THAT ALCOHOL BLENDED FUELS (CALLED GASOHOL OR USING ETHANOL OR METHANOL) CAN ATTRACT MOISTURE WHICH LEADS TO SEPARATION AND FORMATION OF ACIDS DURING STORAGE. ACIDIC GAS CAN DAMAGE THE FUEL SYSTEM OF AN ENGINE WHILE IN STORAGE.

- Empty the fuel tank by starting the engine and let it run until the fuel lines and carburetor are empty.
- Never use engine or carburetor cleaner products in the fuel tank or permanent damage may occur.
- Use fresh fuel next season.

NOTE: Fuel stabilizer is an acceptable alternative in minimizing the formation of fuel gum deposits during storage. Add stabilizer to gasoline in fuel tank or storage container. Always follow the mix ratio found on stabilizer container. Run engine at least 10 minutes after adding stabilizer to allow the stabilizer to reach the carburetor. Do not empty the gas tank and carburetor if using fuel stabilizer.

ENGINE OIL

Drain oil (with engine warm) and replace with clean engine oil. (See “ENGINE” in the Maintenance section of this manual).

CYLINDER(S)

- Remove spark plug(s).
- Pour one ounce of oil through spark plug hole(s) into cylinder(s).
- Turn ignition key to “START” position for a few seconds to distribute oil.
- Replace with new spark plug(s).

OTHER

- Do not store gasoline from one season to another.
- Replace your gasoline can if your can starts to rust. Rust and/or dirt in your gasoline will cause problems.
- If possible, store your tractor indoors and cover it to give protection from dust and dirt.
- Cover your tractor with a suitable protective cover that does not retain moisture. Do not use plastic. Plastic cannot breathe which allows condensation to form and will cause your tractor to rust.

IMPORTANT: NEVER COVER TRACTOR WHILE ENGINE AND EXHAUST AREAS ARE STILL WARM.

TROUBLESHOOTING POINTS

PROBLEM	CAUSE	CORRECTION
Will not start	<ol style="list-style-type: none"> 1. Out of fuel. 2. Engine not "CHOKED" properly. 3. Engine flooded. 4. Bad spark plug. 5. Weak or dead battery. 6. Dirty air filter. 7. Dirty fuel filter. 8. Water in fuel. 9. Loose or damaged wiring. 10. Carburetor out of adjustment. 11. Engine valves out of adjustment. 	<ol style="list-style-type: none"> 1. Fill fuel tank. 2. See "TO START ENGINE" in Operation section. 3. Wait several minutes before attempting to start. 4. Replace spark plug. 5. Recharge or replace battery. 6. Clean/replace air filter. 7. Replace fuel filter. 8. Empty fuel tank and carburetor, refill tank with fresh gasoline and replace fuel filter. 9. Check all wiring. 10. See "To Adjust Carburetor" in Service Adjustments section. 11. Contact an authorized service center/department.
Hard to start	<ol style="list-style-type: none"> 1. Dirty air filter. 2. Bad spark plug. 3. Weak or dead battery. 4. Dirty fuel filter. 5. Stale or dirty fuel. 6. Loose or damaged wiring. 7. Carburetor out of adjustment. 8. Engine valves out of adjustment. 	<ol style="list-style-type: none"> 1. Clean/replace air filter. 2. Replace spark plug. 3. Recharge or replace battery. 4. Replace fuel filter. 5. Empty fuel tank and refill tank with fresh, clean gasoline. 6. Check all wiring. 7. See "To Adjust Carburetor" in Service Adjustments section. 8. Contact an authorized service center/department.
Engine will not turn over	<ol style="list-style-type: none"> 1. Brake pedal not depressed. 2. Attachment clutch is engaged. 3. Weak or dead battery. 4. Blown fuse. 5. Corroded battery terminals. 6. Loose or damaged wiring. 7. Faulty ignition switch. 8. Faulty solenoid or starter. 9. Faulty operator presence switch(es). 	<ol style="list-style-type: none"> 1. Depress brake pedal. 2. Disengage attachment clutch. 3. Recharge or replace battery. 4. Replace fuse. 5. Clean battery terminals. 6. Check all wiring. 7. Check/replace ignition switch. 8. Check/replace solenoid or starter. 9. Contact an authorized service center/department.
Engine clicks but will not start	<ol style="list-style-type: none"> 1. Weak or dead battery. 2. Corroded battery terminals. 3. Loose or damaged wiring. 4. Faulty solenoid or starter. 	<ol style="list-style-type: none"> 1. Recharge or replace battery. 2. Clean battery terminals. 3. Check all wiring. 4. Check/replace solenoid or starter.
Loss of power	<ol style="list-style-type: none"> 1. Cutting too much grass/too fast. 2. Throttle in "CHOKE" position. 3. Build-up of grass, leaves and trash under mower. 4. Dirty air filter. 5. Low oil level/dirty oil. 6. Faulty spark plug. 7. Dirty fuel filter. 8. Stale or dirty fuel. 9. Water in fuel. 10. Spark plug wire loose. 11. Dirty engine air screen/fins. 12. Dirty/clogged muffler. 13. Loose or damaged wiring. 14. Carburetor out of adjustment. 15. Engine valves out of adjustment. 	<ol style="list-style-type: none"> 1. Raise cutting height/reduce speed. 2. Adjust throttle control. 3. Clean underside of mower housing. 4. Clean/replace air filter. 5. Check oil level/change oil. 6. Clean and regap or change spark plug. 7. Replace fuel filter. 8. Empty fuel tank and refill tank with fresh, clean gasoline. 9. Empty fuel tank and carburetor, refill tank with fresh gasoline and replace fuel filter. 10. Connect and tighten spark plug wire. 11. Clean engine air screen/fins. 12. Clean/replace muffler. 13. Check all wiring. 14. See "To Adjust Carburetor" in Service Adjustments section. 15. Contact an authorized service center/department.
Excessive vibration	<ol style="list-style-type: none"> 1. Worn, bent or loose blade. 2. Bent blade mandrel. 3. Loose/damaged part(s). 	<ol style="list-style-type: none"> 1. Replace blade. Tighten blade bolt. 2. Replace blade mandrel. 3. Tighten loose part(s). Replace damaged parts.

TROUBLESHOOTING POINTS

PROBLEM	CAUSE	CORRECTION
Engine dies when tractor is shifted into reverse	<ol style="list-style-type: none"> Reverse operation system (ROS) is not "ON" while mower or other attachment is engaged. 	<ol style="list-style-type: none"> Turn ignition key to ROS "ON" position. See Operation section.
Engine continues to run when operator leaves seat with attachment clutch engaged	<ol style="list-style-type: none"> Faulty operator-safety presence control system. 	<ol style="list-style-type: none"> Check wiring, switches and connections. If not corrected, contact an authorized service center/department.
Poor cut - uneven	<ol style="list-style-type: none"> Worn, bent or loose blade. Mower deck not level. Buildup of grass, leaves, and trash under mower. Bent blade mandrel. Clogged mower deck vent holes from buildup of grass, leaves, and trash around mandrels. 	<ol style="list-style-type: none"> Replace blade. Tighten blade bolt. Level mower deck. Clean underside of mower housing. Replace blade mandrel. Clean around mandrels to open vent holes.
Mower blades will not rotate	<ol style="list-style-type: none"> Obstruction in clutch mechanism. Worn/damaged mower drive belt. Frozen idler pulley. Frozen blade mandrel. 	<ol style="list-style-type: none"> Remove obstruction. Replace mower drive belt. Replace idler pulley. Replace blade mandrel.
Poor grass discharge	<ol style="list-style-type: none"> Engine speed too slow. Travel speed too fast. Wet grass. Mower deck not level. Low/uneven tire air pressure. Worn, bent or loose blade. Buildup of grass, leaves and trash under mower. Mower drive belt worn. Blades improperly installed. Improper blades used. Clogged mower deck vent holes from buildup of grass, leaves, and trash around mandrels. 	<ol style="list-style-type: none"> Place throttle control in "FAST" position. Shift to slower speed. Allow grass to dry before mowing. Level mower deck. Check tires for proper air pressure. Replace blade. Tighten blade bolt. Clean underside of mower housing. Replace mower drive belt. Reinstall blades sharp edge down. Replace with blades listed in this manual. Clean around mandrels to open vent holes.
Headlight(s) not working (if so equipped)	<ol style="list-style-type: none"> Light switch is "OFF". Bulb(s) or lamp(s) burned out. Faulty light switch. Loose or damaged wiring. Blown fuse. 	<ol style="list-style-type: none"> Turn light switch "ON". Replace bulb(s) or lamp(s). Check/replace light switch. Check wiring and connections. Replace fuse.
Battery will not charge	<ol style="list-style-type: none"> Bad battery cell(s). Poor cable connections. Faulty regulator (if so equipped). Faulty alternator. 	<ol style="list-style-type: none"> Replace battery. Check/clean all connections. Replace regulator. Replace alternator.
Loss of drive	<ol style="list-style-type: none"> Freewheel control in "disengaged" position. Motion drive belt worn, damaged, or broken. Air trapped in transmission during shipment or servicing. 	<ol style="list-style-type: none"> Place freewheel control in "engaged" position. Replace motion drive belt. Purge transmission.
Engine "backfires" when turning engine "OFF"	<ol style="list-style-type: none"> Engine throttle control not set between half and full speed (fast) position before stopping engine. 	<ol style="list-style-type: none"> Move throttle control between half and full speed (fast) position before stopping engine.

TRACTOR - - MODEL NUMBER 944.606912

SCHEMATIC

03094-194276_Manual-Tex

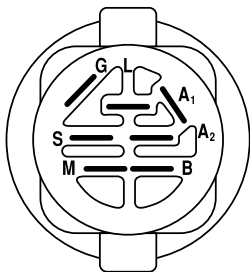
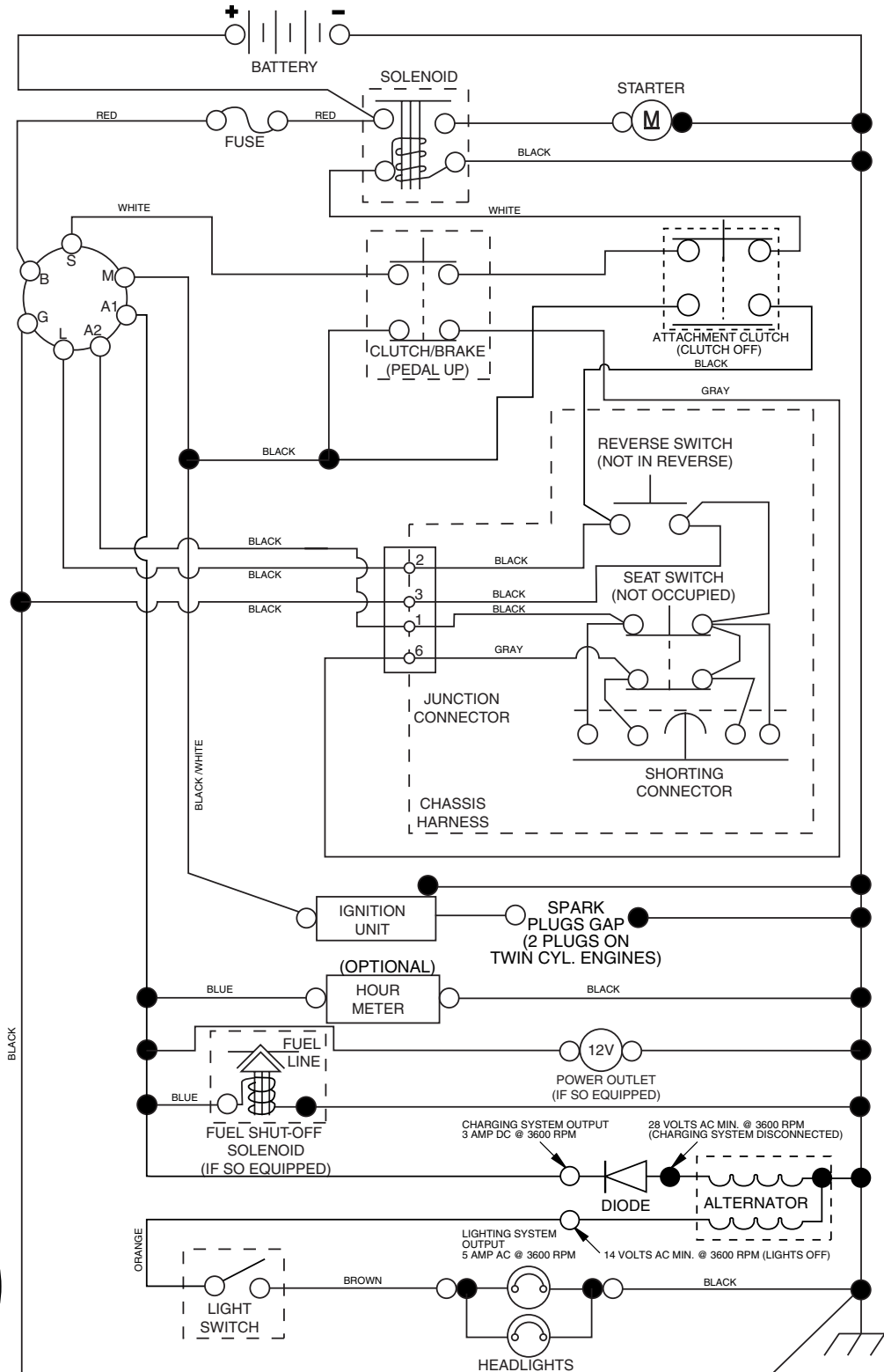

IGNITION SWITCH

POSITION	CIRCUIT "MAKE"
OFF	M+G+A1
RUN/OVERRIDE	B+A1
RUN	B+A1 L+A2
START	B + S + A1

03094

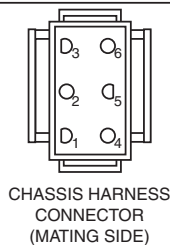

CHASSIS HARNESS CONNECTOR (MATING SIDE)

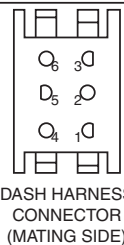

DASH HARNESS CONNECTOR (MATING SIDE)

WIRING INSULATED CLIPS
NOTE: IF WIRING INSULATED CLIPS WERE REMOVED FOR SERVICING OF UNIT, THEY SHOULD BE REPLACED TO PROPERLY SECURE YOUR WIRING.

●
NON-REMOVABLE CONNECTIONS

○
REMOVABLE CONNECTIONS

TRACTOR - - MODEL NUMBER 944.606912

ELECTRICAL

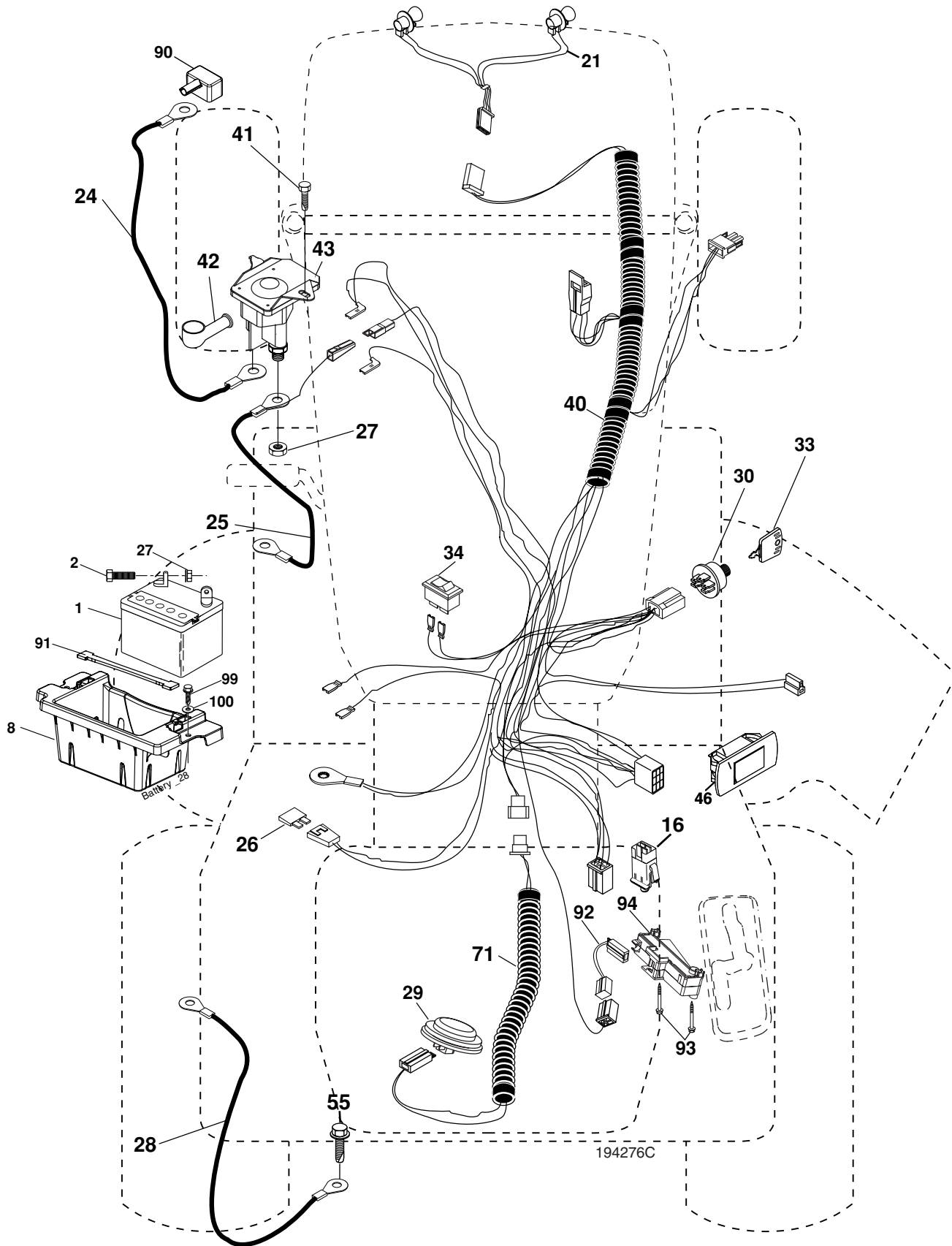

TRACTOR - - MODEL NUMBER 944.606912

ELECTRICAL

KEY NO.	PART NO.	DESCRIPTION
1	144927	Battery
2	74760412	Bolt Hex Head 1/4-20 x 3/4
8	186491	Box Battery
16	176138	Switch Interlock Push-In
21	400252	Harness Socket Light
22	4152J	Bulb Light
24	400253	Cable Btry.
25	198893	Cable Starter
26	175158	Fuse
27	73510400	Nut Keps Hex 1/4-20 unc
28	145491	Cable, Ground
29	192749	Switch, Seat
30	193350	Switch, Ign
33	140403	Key, Ignition
34	110712X	Switch Light / Reset
40	194276	Harness Ign.
41	17720408	Screw Thd Cut 1/4-20 x 1/2
42	131563	Cover, Terminal
43	192507	Solenoid
46	198138	Gauge Hourmeter
55	17490512	Screw Thdrol 5/16-18 x 3/4 TYTT
71	401098	Harness Ign. Dash
90	400724	Cover Terminal Battery
91	190270	Strap Battery Mount Front
92	196615	Harness Pigtail
93	192540	Screw Plastite 10-14 x 2.0
94	191834	Module Reverse ROS
99	17670412	Screw Hexwsh Thdrol 1/4-20 x 3/4
100	19091416	Washer 9/32 x 7/8 x 16 Ga.

NOTE: All component dimensions given in U.S. inches
1 inch = 25.4 mm

TRACTOR - - MODEL NUMBER 944.606912

CHASSIS

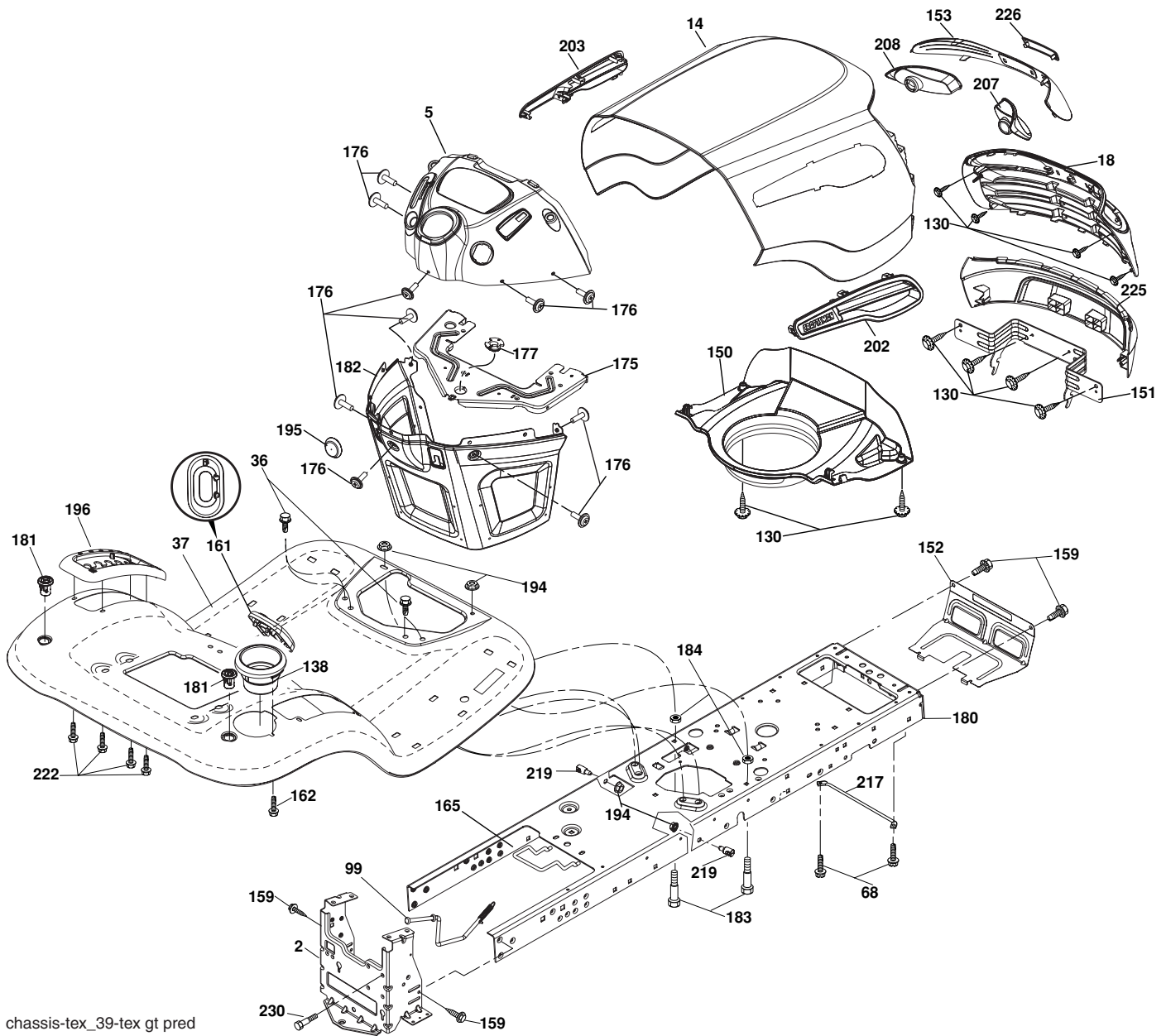

chassis-tex_39-tex gt pred

TRACTOR - - MODEL NUMBER 944.606912

CHASSIS

KEY NO.	PART NO.	DESCRIPTION
2	194263	Drawbar
5	199674X428	Dash
14	404654X615	Hood
18	404624	Grille
36	17060512	Screw 5/16-18 x 3/4
37	405107X615	Fender
68	17490508	Screw THDROL 5/16-18 x 1/2
99	401530	Rod Bypass Asm
130	191611	Screw 10 x 3/4 Single Lead-Hex
138	193224X428	Cupholder
150	199412	Duct Heat Hood
151	196332	Bracket Pivot
152	194329	Shield Browning/Debris
153	198965	Lens Bar
159	17000612	Screw Hexwsh Thdrol 3/8-16 x 3/4
161	193229X428	Window Fuel
162	142432	Screw Hex Wsh Hi-Lo 1/4 x 1/2 unc
165	400315	Support Tank Rear
175	196304	Crossmember
176	400776	Screw 10-24 x 5/8 Wshd Qdrx
177	195227	Bushing Steering
180	194260	Chassis
181	193102X428	Bushing Mtg. Fender Crgo.
182	194787	Dash Lower
183	74780520	Bolt Fin Hex 5/16-18 x 1-1/4
184	195780	Spacer Fender
194	73900500	Nut Lock Hex Flange 5/16-18
195	401556X428	Plug Hole Dash Lower
196	196378X428	Console Asm. Deck Lift
197	156524	Rod Pivot Chassis
202	198968X428	Vent Side Hood RH
203	198969X428	Vent Side Hood LH
207	198963	Bezel RH
208	198964	Bezel LH
219	195161	Stud Fastener
222	137729	Screw Thd Roll 1/4-20 x 5/8
225	198962X615	Bumper
226	198967X428	Logo
230	170165	Bolt Shoulder 5/16-18
--	199783X428	Plug Cruise/Hook/Phone

NOTE: All component dimensions given in U.S. inches
1 inch = 25.4 mm

TRACTOR - - MODEL NUMBER 944.606912

DRIVE

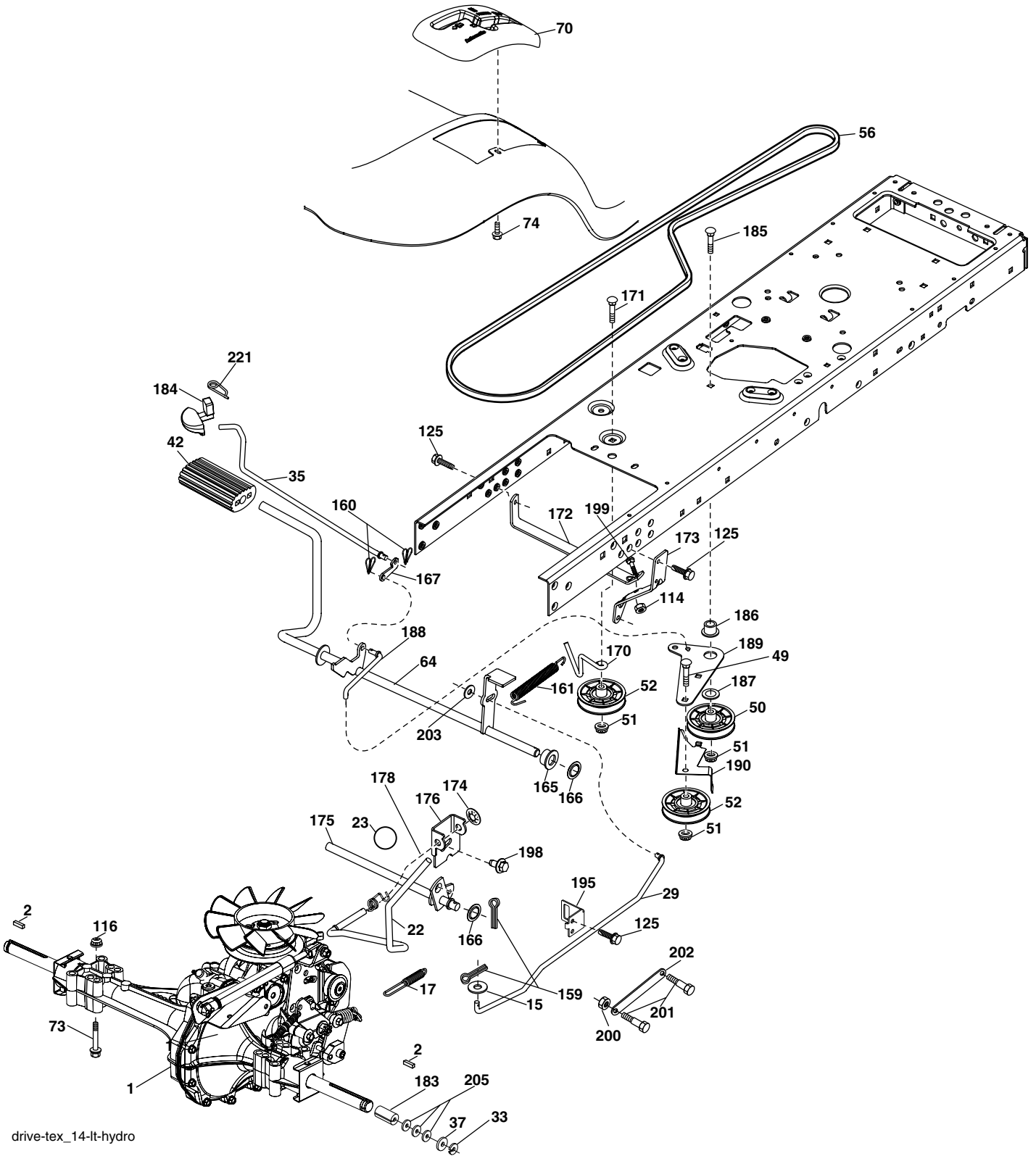

drive-tex_14-lt-hydro

TRACTOR - - MODEL NUMBER 944.606912

DRIVE

KEY NO.	PART NO.	DESCRIPTION	KEY NO.	PART NO.	DESCRIPTION
1	-----	Transaxle, Hydro 351-0510 (See transaxle breakdown)	167	196211	Latch Brake Parking
2	123583X	Key	170	194322	Keeper Belt Centerspan
15	19131316	Washer 13/32 x 13/16 x 16 Ga.	171	72110616	Bolt
17	197296	Spring, Brake	172	197656	Strap Torque LH
22	197660	Rod Shift	173	197655	Strap Torque RH
23	130564	Knob Deluxe	174	197289	Nut Push
29	197659	Rod, Brake	175	197653	Shaft Asm
33	12000001	Ring E	176	196214	Asm Clevis Rod Shift
35	199591	Rod, Brake, Park	178	197456	Spring Shift
37	121749X	Washer 25/32 x 1-1/4 x 16 Ga.	183	137057	Spacer Axle
42	8883R	Cover, Foot Pedal	184	196439X505	Handle Parking Brake
49	72110614	Bolt	185	72110620	Bolt
50	194327	Pulley Idler Flat	186	194321	Spacer Retainer
51	73900600	Lock Nut 3/8-16	187	19133210	Washer
52	194326	Idler V-Groove 910" Offset	188	194323	Link Clutch Ground Drive
56	140218	V-Belt, Drive	189	194317	Bellcrank Ground Drive
64	196200	Shaft Asm. Pedal Brake Control	190	194318	Keeper Bellcrank Ground Drive
70	193220X428	Console Shift	195	198012	Bracket Rod Brake
73	74490544	Bolt Hex Flghd 5/16-18 Gr. 5	198	199496	Screw 7/16-147 x 7/8 flange head
74	142432	Screw Hex wsh Hi-Lo 1/4 x 1/2 unc	199	72140508	Bolt RDHD SQNK 5/16-18 unc x 1
114	73800500	Nut Lock Hex W/INS 5/16-18 unc	200	73930500	Nut Center Lock 5/16-18 unc
116	73900500	Nut Lock Hex Flange 5/16-18	201	169612	Bolt Shoulder 5/16-18 unc
125	17000512	Screw 5/16-18 x 3/4	202	197714	Link Trans
159	76020412	Pin Cotter 1/8 x 3/4	203	19111116	Washer 11/32 x 11/16 x 16 Ga.
160	169484	Retainer Clip	205	121748X	Washer 25/32 x 1-5/8 x 16 Ga.
161	195403	Spring, Return, Clutch	221	403187	Retainer Spring Clip Handle
165	196212	Bushing			
166	197290	Nut Push .625			

NOTE: All component dimensions given in U.S. inches
1 inch = 25.4 mm

TRACTOR - - MODEL NUMBER 944.606912

STEERING ASSEMBLY

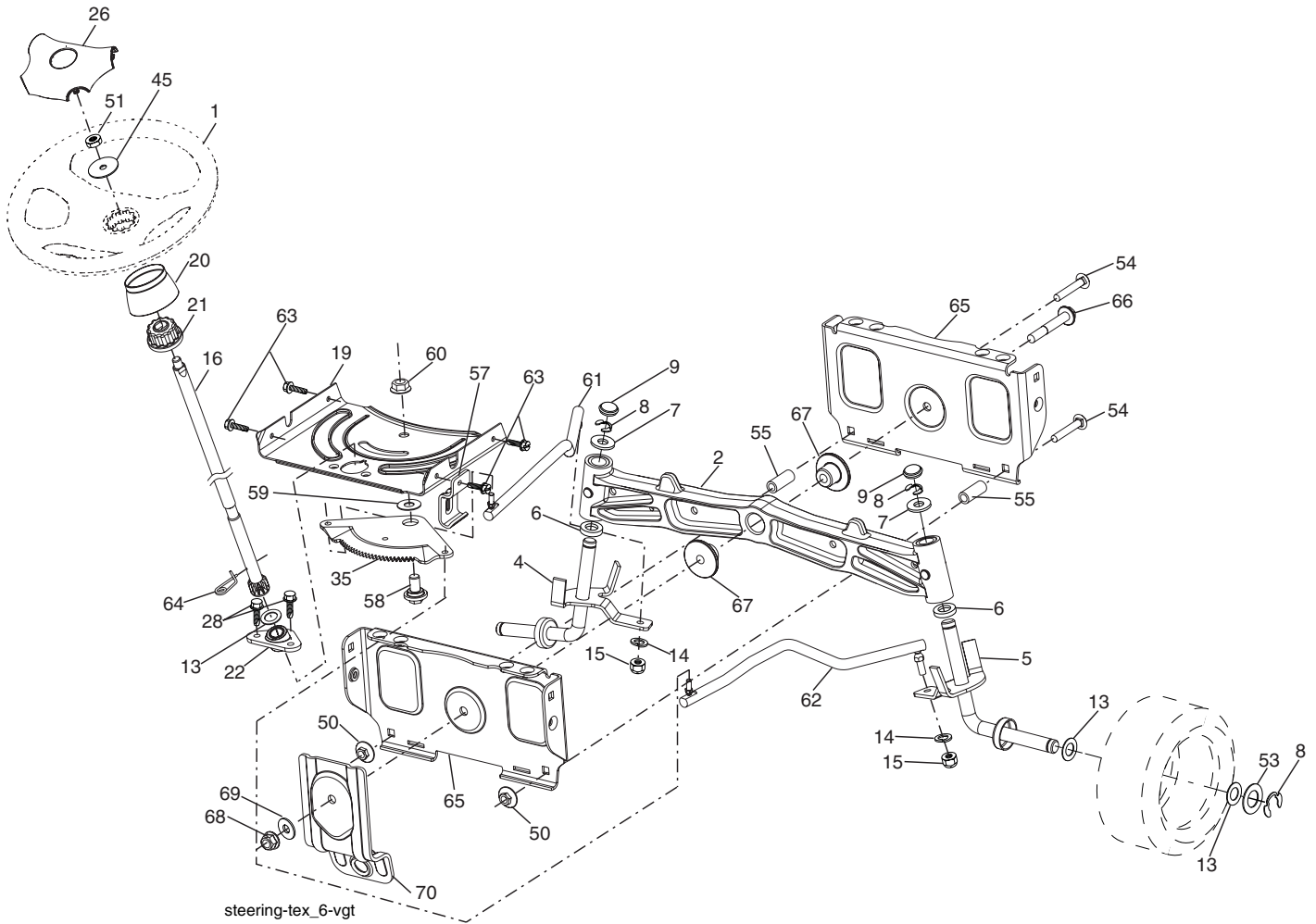

TRACTOR - - MODEL NUMBER 944.606912

STEERING ASSEMBLY

KEY NO.	PART NO.	DESCRIPTION
1	186093X428	Wheel, Steering
2	195968	Axle Asm., Front
4	403087	Spindle Asm., LH
5	403088	Spindle Asm., RH
6	6266H	Bearing, Race Thrust Harden
7	121748X	Washer 25/32 x 1-5/8 x 16 Ga.
8	1200029	Ring, Klip #T5304-75
9	184946X505	Cap, Spindle
13	121749X	Washer 25/32 x 1-1/4 x 16 Ga.
14	10040600	Washer, Lock Hvy Hlcl Spr 3/8
15	73540600	Nut, Crown Lock 3/8-24 unf
16	194746	Shaft Steering
19	194729	Plate Steering
20	199676X428	Boot, Steering
21	186737	Adapter, Wheel Steering
22	194845	Bushing, Strg. Blk
26	186095X428	Insert, Wheel Steering
28	17000612	Screw 3/8-16 x 3/4
35	194732	Gear, Sector Plate
45	19183812	Washer 9/16 ID x 2-3/8 OD x 12 Ga.
50	73900600	Nut Lock 3/8-16 unc
51	73940800	Nut Hex Jam Toplock 1/2-20 unf
53	188967	Washer Hardened .793 x 1.637 x .060
54	74760636	Bolt Hex 3/8-16 unc x 2-1/4
55	197636	Spacer Brace Axle
57	197246	Bracket Upstop
58	194747	Bolt Shoulder Sector Pivot CFM
59	194748	Washer Thrust Sector Steering
60	73971000	Nut Flange Lock 5/8-11
61	194740	Draglink LH
62	194741	Draglink, RH
63	17000512	Screw 5/16-18 x 3/4
64	199849	Retainer Clip Spring Steering
65	194734	Brace Axle Front
66	71020748	Bolt Hex Fghd 7/16-14 x 3 Serr
67	194737	Bushing PM Front Axle
68	73900700	Nut Lock Flange 7/16-14 Gr. 5
69	199162	Washer 1.5 x .505 x .118
70	196197	Bracket Deck Susp. Front

NOTE: All component dimensions given in U.S. inches
1 inch = 25.4 mm

TRACTOR - - MODEL NUMBER 944.606912

ENGINE

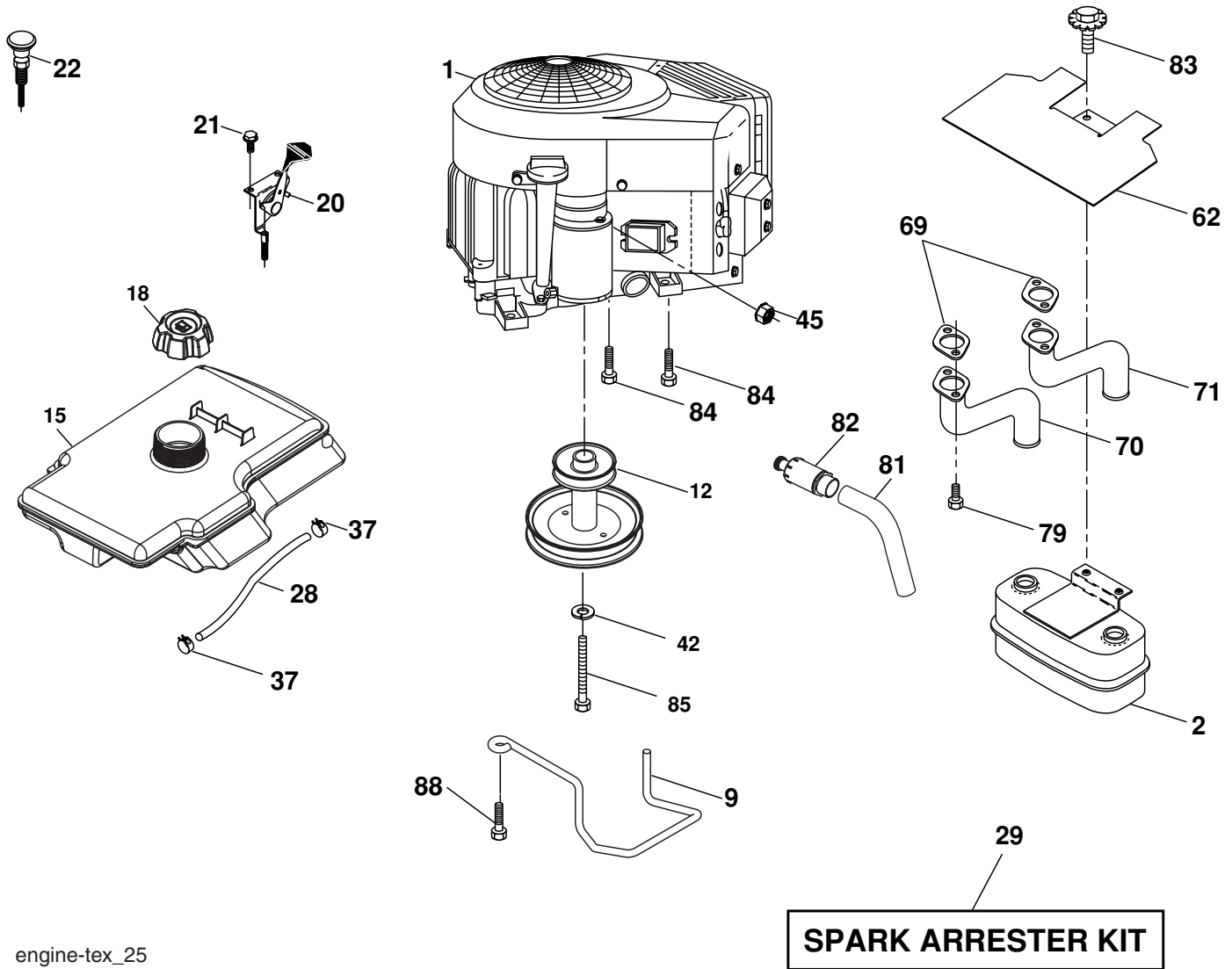

engine-tex_25

KEY NO.	PART NO.	DESCRIPTION
1	-----	Engine Briggs Model No. 406577-0411-E1 (See Breakdown)
2	149723	Muffler
9	194319	Keeper Belt Engine
12	401985	Pulley Engine
15	197024	Tank Fuel
18	195951	Cap Asm
20	175437X428	Control Throttle
21	191611	Screw 10 x 3/4 Single Lead-Hex
22	187767X428	Control Choke
28	8543R	Fuel Line
29	137180	Spark Arrester Kit
37	123487X	Clamp Hose
42	10040700	Washer Lock 7/16
45	73510400	Nut Keps Hex 1/4-20 unc
62	146629	Shield Heat Muffler

KEY NO.	PART NO.	DESCRIPTION
69	165391	Gasket
70	159955	Exhaust Tube LH
71	160589	Exhaust Tube RH
79	183906	Screw Socket Head 5/16-18 x .75
81	148456	Tube Drain Oil Easy
82	181654	Plug Drain Oil
83	171877	Bolt 5/16-18 x 3/4
84	17060620	Screw 3/8-16 x 1-1/4
85	173937	Bolt Hex 7/16-20 x 4 x Gr. 5-1.5
88	17060616	Screw 3/8-16 x 1

NOTE: All component dimensions given in U.S. inches
1 inch = 25.4 mm

TRACTOR - - MODEL NUMBER 944.606912

SEAT ASSEMBLY

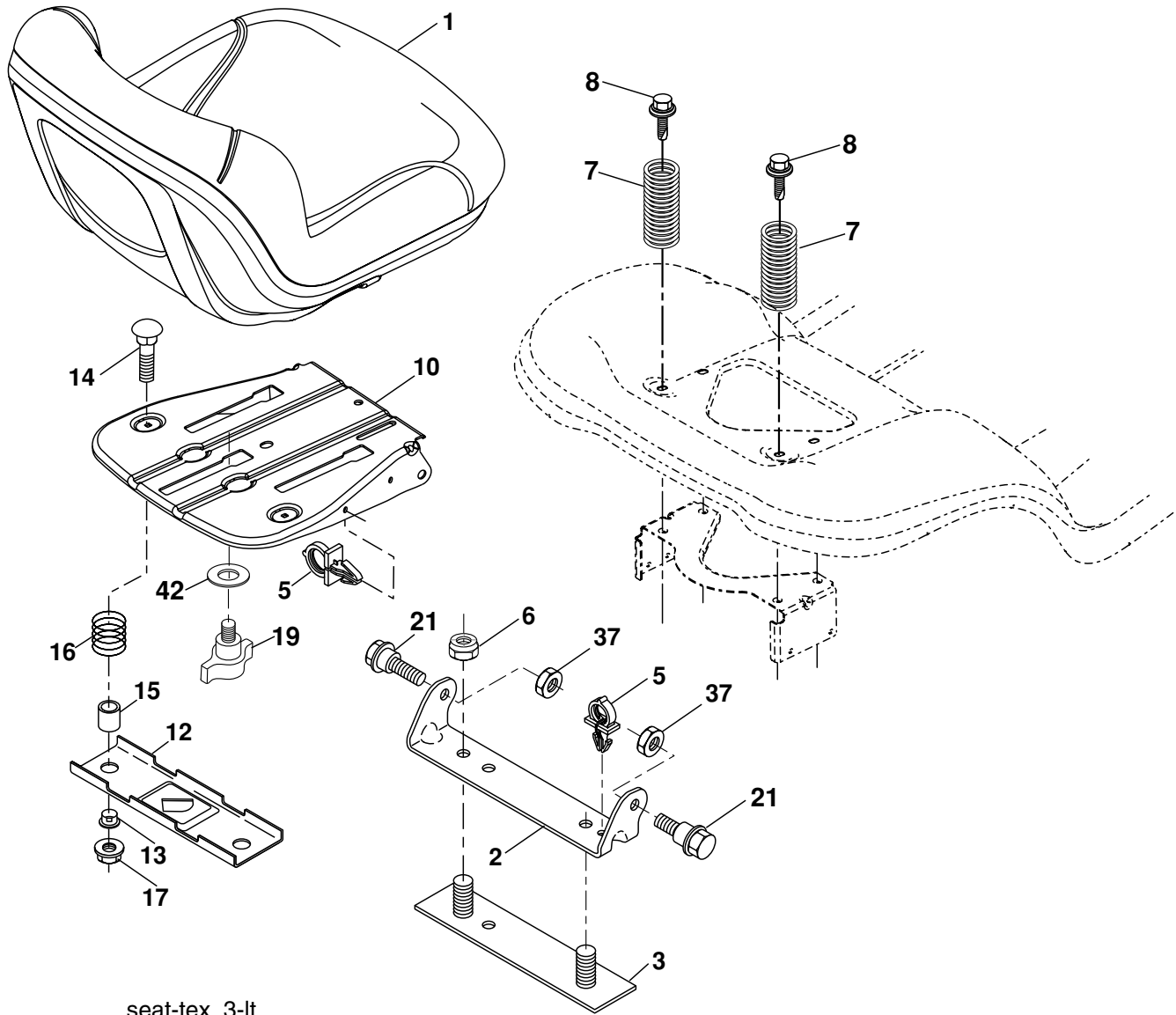

seat-tex_3-lt

KEY NO.	PART NO.	DESCRIPTION
1	197520	Seat
2	180166	Bracket Pivot Fender
3	140675	Strap, Asm Fender
5	145006	Clip, Push In, Hinged
6	73800600	Nut, Lock W/Ins. 3/8-16 unc
7	124181X	Spring, Seat Cprsn
8	171877	Bolt 5/16-18 uncx 3/4 w/Sems
10	199180	Pan, Seat
12	199370	Bracket Mnt Opc Seat
13	121248X	Bushing Snap
14	72050412	Bolt Rdhd Sh Nk 1/4-20 x 1-1/2

KEY NO.	PART NO.	DESCRIPTION
15	134300	Spacer Split .28 x .96
16	123740X	Spring
17	123976X	Nut Lock 1/4 Lrg Flg Gr. 5
19	199372	Knob Seat
21	171852	Bolt, Shoulder 5/16-18
37	73800500	Nut, Lock 5/16-18 unc
42	199371	Washer

NOTE: All component dimensions given in U.S. inches
1 inch = 25.4 mm

TRACTOR - - MODEL NUMBER 944.606912

DECALS

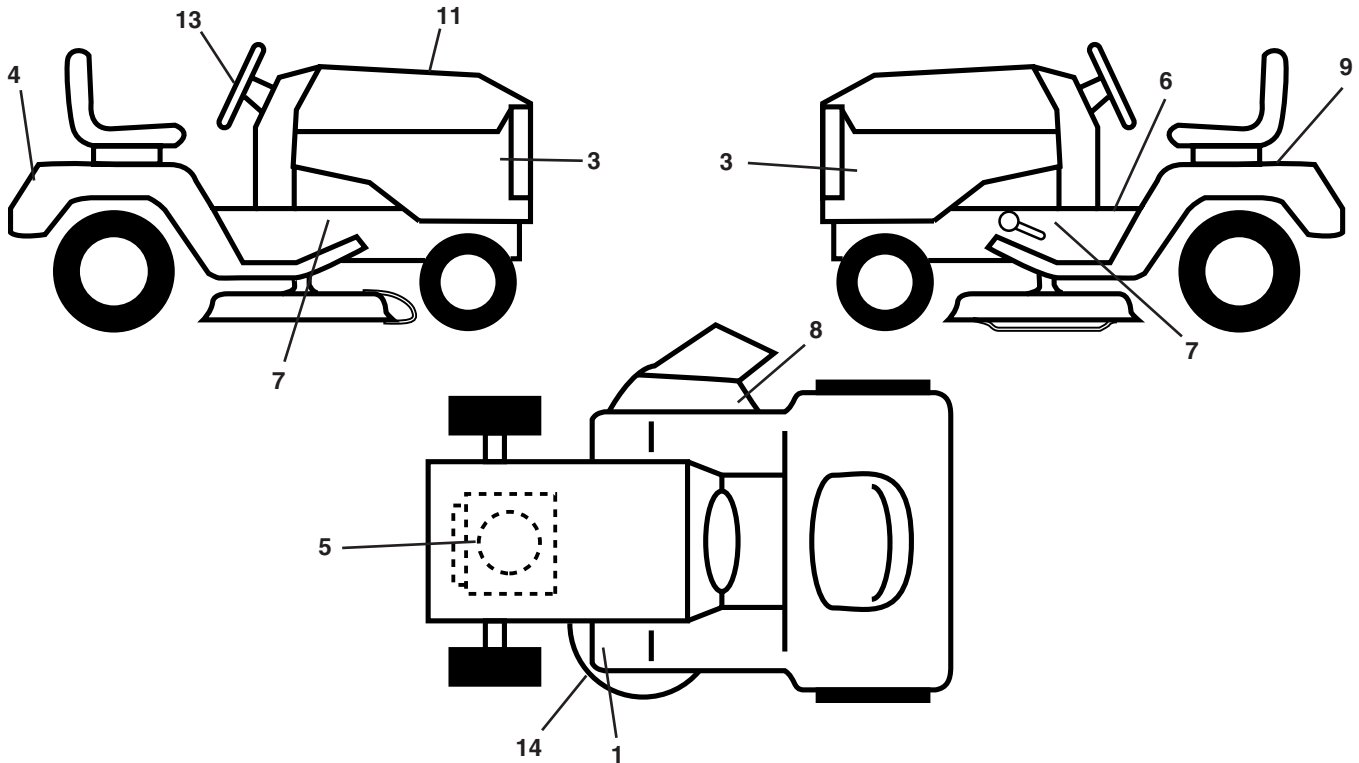

KEY NO.	PART NO.	DESCRIPTION
1	199135	Decal, Mower V-Belt Sch
3	403260	Decal, Side Panel
4	403259	Decal, Fender
5	189525	Decal, Engine
6	199114	Decal, Fender Operator's
7	405070	Decal, Chas 20 B&S
8	170563	Decal, Warning
9	149517	Decal, Battery Dnge/Poi
11	405042	Decal, Replacement

KEY NO.	PART NO.	DESCRIPTION
13	164065	Decal, Steering Wheel
14	160396	Decal, Mower Schematic
--	193227X428	Pad, Footrest, RH
--	166960	Decal, Bypass
--	193226X428	Pad, Footrest, LH
--	406211	Manual, Owner's English
--	406212	Manual, Owner's French

WHEELS AND TIRES

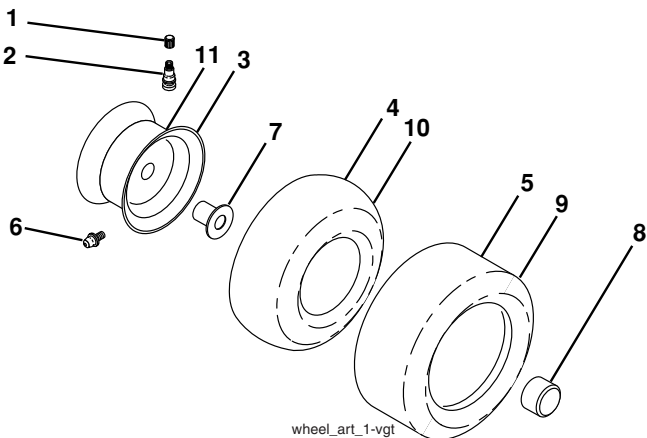

KEY NO.	PART NO.	DESCRIPTION
1	59192	Cap, Valve, Tire
2	65139	Stem, Valve
3	106732X643	Rim Assembly, Front
4	59904	Tube, Front
5	106222X	Tire, Front
6	278H	Fitting, Grease
7	9040H	Bearing, Flange
8	104757X643	Cap, Axle (Front Wheel Only)
9	138468	Tire, Rear
10	7152J	Tube, Rear
11	106108X643	Rim Assembly, Rear
--	144334	Sealant, Tire (10 oz. Tube)

NOTE: All component dimensions given in U.S. inches
1 inch = 25.4 mm

TRACTOR - - MODEL NUMBER 944.606912

MOWER LIFT

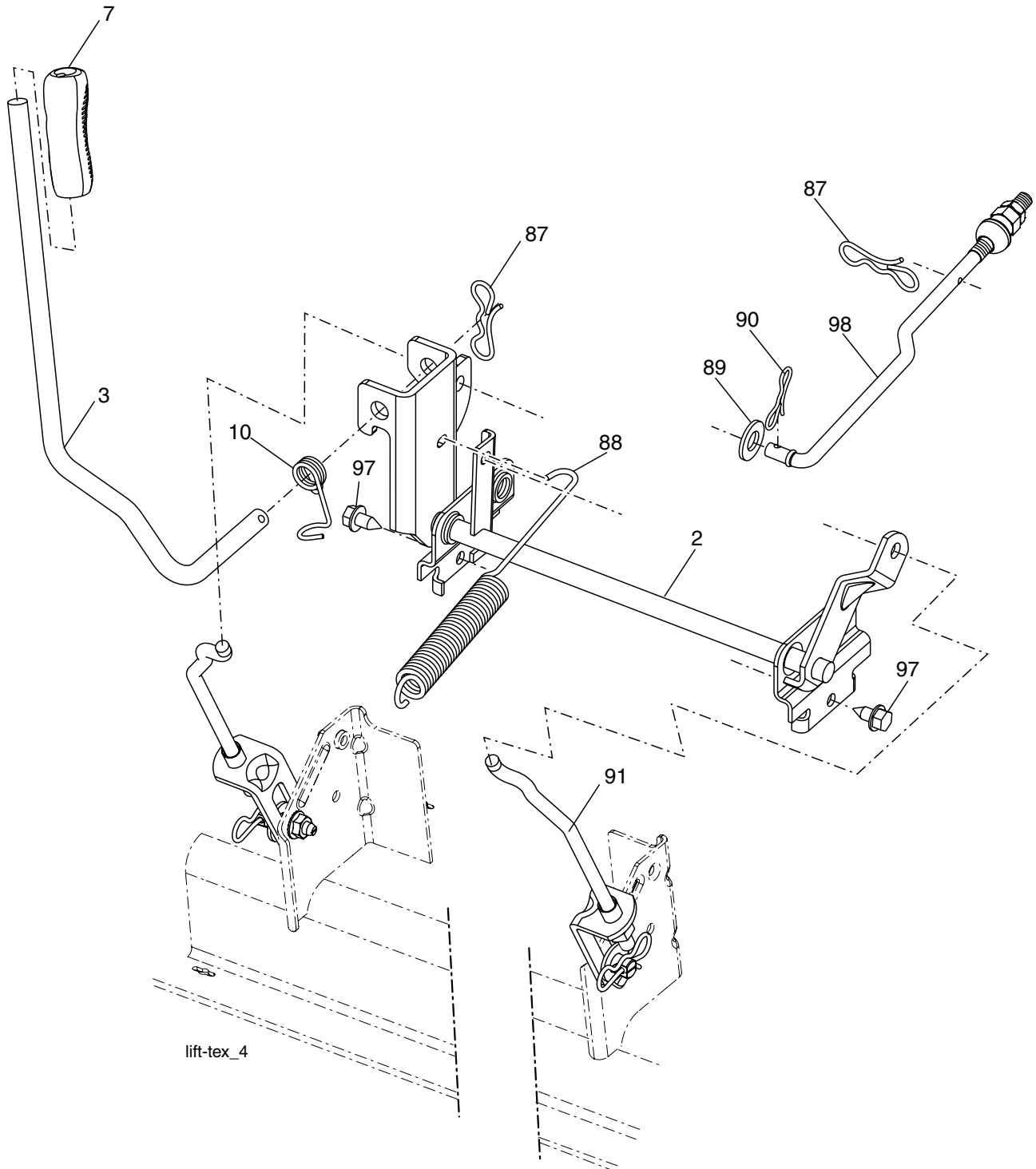

KEY NO.	PART NO.	DESCRIPTION
2	195223	Shaft Asm., Lift
3	195231	Lever Asm., Lift Rh
7	196492	Grip, Lever
10	196314	Spring Torsion
87	194209	Pin Cotter 7/16 Bow Tie Lock
88	195303	Spring Lift Assist
89	19191912	Washer Clear Zinc
90	194208	Pin Cotter 5/16 Bow Tie Lock

KEY NO.	PART NO.	DESCRIPTION
91	195181	Link Asm. Lift Rear
97	17060612	Screw 3/8-16 x .75 Smgml Tap/R.Z
98	195270	Link Lift Susp. Front Mower

NOTE: All component dimensions given in U.S. inches
1 inch = 25.4 mm

TRACTOR - - MODEL NUMBER 944.606912

MOWER DECK

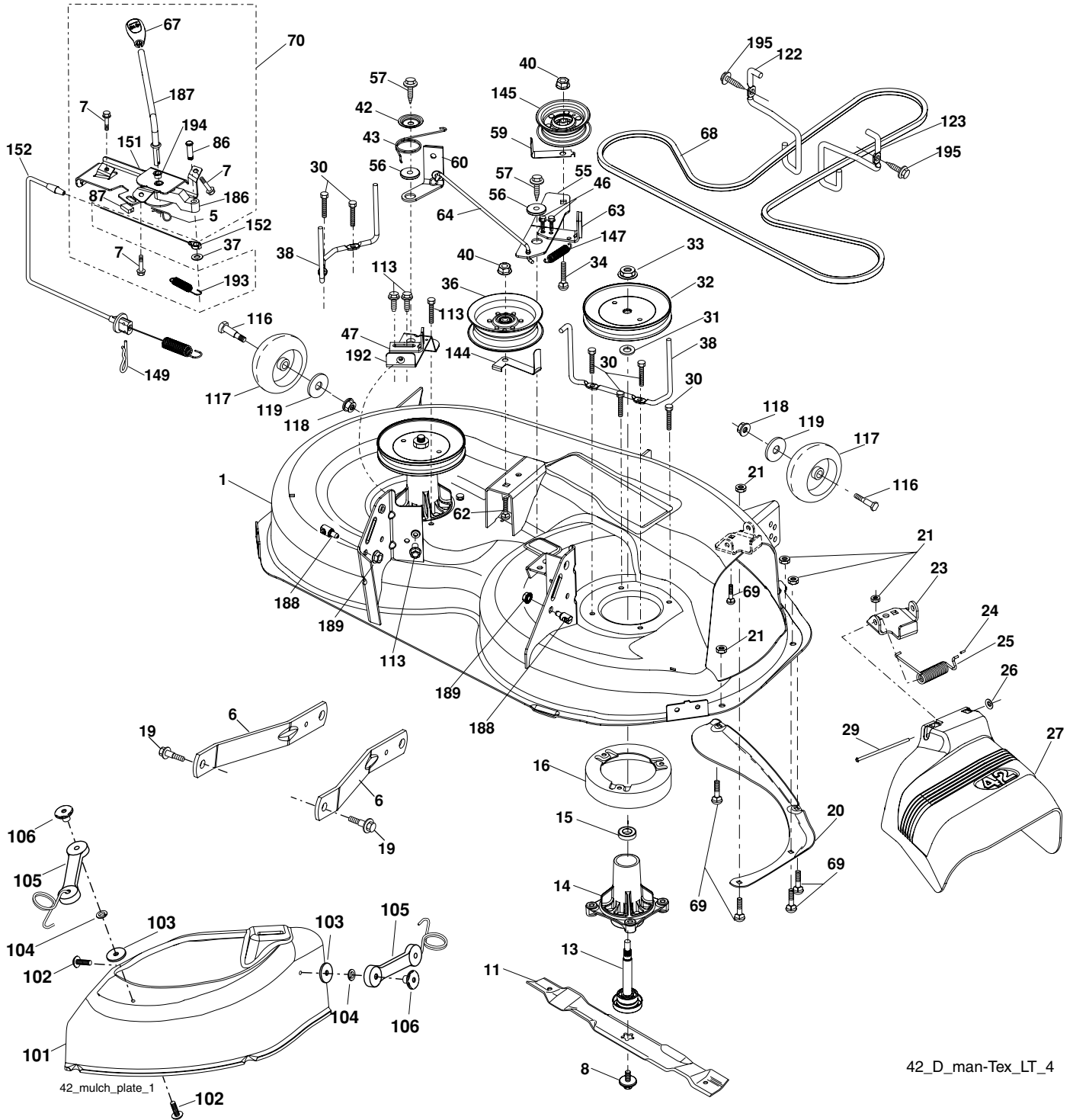

42_D_man-Tex_LT_4

TRACTOR - - MODEL NUMBER 944.606912

MOWER DECK

KEY NO.	PART NO.	DESCRIPTION	KEY NO.	PART NO.	DESCRIPTION
1	196495	Deck Weldment Mower	63	199477	Arm Brake Mower
5	4939M	Retainer Spring	64	199790	Link Brake Asm
6	195186	Arm Suspension	67	198398X505	Handle Clutch Cable
7	191611	Screw 10 x 3/4 Single Lead Hex	68	197253	V-Belt
8	193003	Bolt/Washer asm 7/16-20 unf	69	72140505	Bolt
11	138971	Blade, 42" Hi-Lift (For bagging or discharge)	70	199972	Clutch Asm Manual
--	134149	Blade, 42" Mulching Std (For mulching mowers only)	86	197798	Pin Attachment Cable
--	139775	Blade, 42" Mulching Premium (For better wear when mulching)	87	197802	Switch Interlock Clutch Cable
13	192872	Shaft Assembly, Mandrel	101	193107	Cover Mulching
14	187281	Housing, Mandrel	102	71081010	Screw Pan Hd Phillips 10-24 x 5/8
15	110485X	Bearing, Ball, Mandrel	103	19061216	Washer #10
16	174493	Stripper, Mower Deck	104	1007100	Washer Lock #10
19	196539	Bolt, Shoulder	105	160793	Latch Asm
20	159770	Baffle, Vortex	106	2029J	Nut Weld .327-.304 #10-24
21	73680500	Nut, Crownlock 5/16-18 unc	113	17000510	Bolt 5/16-18
23	192557	Bracket, Deflector	116	4898H	Bolt, Shoulder
24	105304X	Cap, Sleeve	117	188606	Wheel, Gauge
25	197026	Spring, Torsion, Deflector	118	73930600	Nut, Crownlock 3/8-1
26	110452X	Nut, Push	119	19121414	Washer 13/32 x 7/8 x 14 Ga.
27	193108X428	Shield, Deflector	122	197258	Keeper Belt Engine LH
29	131491	Rod, Hinge	123	197259	Keeper Belt Engine RH
30	173984	Screw Thdrol Rolling Wsh Hd	144	199204	Keeper Belt
31	187690	Washer, Spacer	145	193197	Pulley Idler
32	197473	Pulley, Mandrel	147	401971	Spring Return
33	400234	Nut, Toplock, Flanged	149	165898	Retainer Spring
34	72110612	Bolt Carr Sh. 3/8-16 x 1-1/2 Gr. 5	151	199971	Bracket Clutch
36	197379	Pulley, Idler, Flat	152	197257	Manual Clutch Cable
37	19131316	Washer	186	197799	Arm Actuator
38	199189	Keeper Belt LH Mandrel	187	199869	Lever Control
40	73900600	Nut, Lock Flg. 3/8-16 unc	188	195161	Stud Fastener
42	198410	Spring Torsion Brake	189	73900500	Nut Lock Hex Flange
43	197256	Spring Torsion Retainer	192	197260	Bracket Brake Stand LH
46	137729	Screw Thd Roll 1/4-20 x 5/8	193	197801	Spring Plunger Activator
47	197250	Bracket Clutch Cable	194	197797	Bearing Control Lever Clutch
55	197249	Arm, Idler	195	17000612	Screw Hex Wsh Thdr 3/8-16 x 3/4
56	199092	Spacer, Retainer	--	192870	Mandrel Assembly (Includes housing, shaft and shaft hardware only-pulley not included)
57	17000616	Screw 3/8-16 x 1	--	405126	Replacement Mower, Complete
59	141043	Guard, Tuv Idler			
60	197261	Arm Brake Mower			
62	72110616	Bolt Rd Hd Sq Nk 3/8-16 unc x 2			

NOTE: All component dimensions given in U.S. inches
1 inch = 25.4 mm

REPAIR PARTS

TRACTOR - - MODEL NUMBER 944.606912

HYDRO TRANSAXLE - - MODEL NUMBER 351-0510

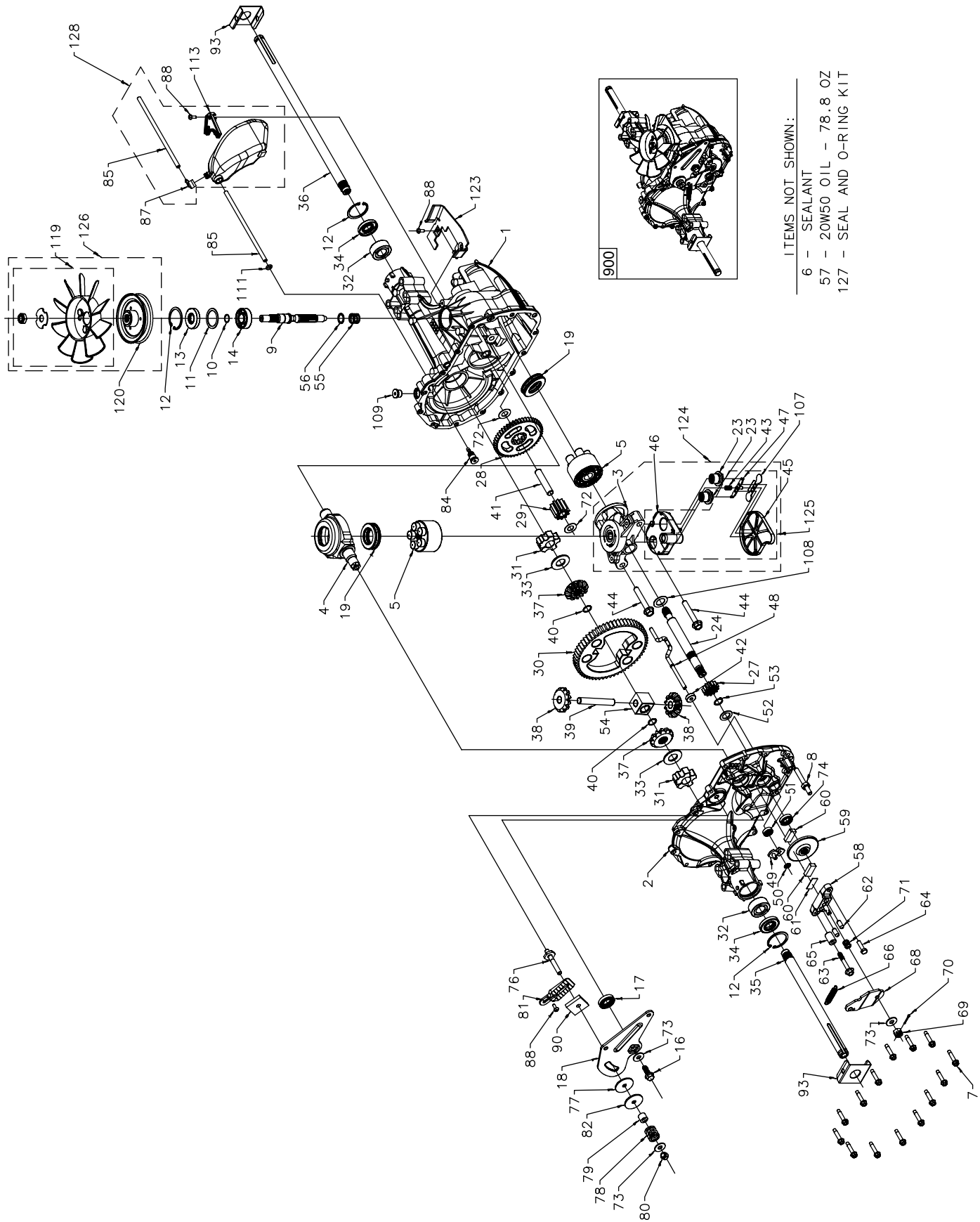

REPAIR PARTS

TRACTOR - - MODEL NUMBER 944.606912

HYDRO TRANSAXLE - - MODEL NUMBER 351-0510

KEY PART NO.	NO.	DESCRIPTION	KEY PART NO.	NO.	DESCRIPTION
1	170351	Kit, Main Housing	68	401263	Arm-brake, RH
		Main Housing, Machined	69	170415	Nut, Castle 5/16-24
		Bushing .865 X .985 X .790	70	170416	Pin, Cotter 3/32x3/4
2	170352	Kit, Side Housing	71	170417	Brake Spring
		Side Housing, Machined	72	170418	Washer (310-0750)
		Bushing .865 X .985 X .790	73	142884	Washer, Flat
		Bushing .624 X .719 X .562	74	170419	Seal, Oil
3	170353	Kit, Center Section	75	170420	Ass'y Check Plug
		Center Section, Machined	76	170421	Bolt, Stud 5/16-24
		Bushing .707 X .788 X .591	77	170422	Puck, Friction
4	170354	Swashplate, Trunnion Machined	78	142969	Spring
5	169898	Kit, Cylinder Block (10CC)	79	142980	Spacer
		Block - Cylinder	80	150778	Nut, Nylon Insert Hex Lock 5/16-24
		Piston	81	170423	Wedge, Friction
		Spring, Compression	82	170424	Clip, Washer
		Washer Thrust	84	170425	Fitting, 5/16 X Sae 5/32 Tube
6	178322	Sealant Tube	85	170426	Hose, Expansion Tank
7	170356	Hexflange Screw 1/4-20 X 1.25	87	401264	Cap, Barbed Vent
8	170357	Stud, 5/16-24 Hex Double End	88	178334	Bolt, Self Tapping (BDR)
9	170358	Shaft, Input	90	170430	Puck, Inner Wedge
10	170359	Retaining Ring	93	170431	Spring Clip, Housing
11	170360	Spacer	107	170432	Deflector
12	169870	Retaining Ring	108	170433	Washer, Motor Shaft .71id X 1.15OD X .03 Thick
13	170361	Seal, Lip .67 X 1.58 X .276	109	170434	Plug, Straight Thread 9/16-18
14	173158	Bearing, Ball 6203 (BDR)	111	170435	O-ring .7 X .301 ID
16	170362	Hex Flange Head Screw 1/4-20 X 1.25	113	170437	Bracket, Support Expansion Tank
17	170363	Seal, Lip 18 X 32 X 7	119	191031	Kit, Fan - Washer - Nut
18	170364	Arm, Control			Fan, 7 In
19	173159	Bearing, Thrust (10cc)			Hex Lock Nut 1/2-20 (Nylon Insert)
23	170365	Check Plug Assembly			Washer, Or Slotted, .53 X 1.63 X .06
24	170366	Shaft Motor	120	170440	Pulley
27	170367	Gear, Pinion, 13T	123	401265	Belt Keeper
28	170368	10T / 48T Gear	124	170444	Kit, Center Section Filter Bypass
29	170369	Gear, 10T Jackshaft			Center Section Machining
30	170370	60T Bullgear			Base Filter W/ Poppet
31	170371	Sleeve Bearing .75 X 1.75 X .625			Check Plug Assembly, .027 Washer
32	170389	Sleeve Bearing (Outboard) .75 X 1.575 X .625			Check Plug Assembly, Washer
33	142991	Washer			Spring, Bypass
34	170390	Lip Seal, Axle Shaft			Actuator, Bypass
35	170391	Shaft, Axle (Keyed, R.H.)			Deflector
36	170392	Shaft, Axle (Keyed, L.H.)			Bottom, Filter
37	401260	Miter Gear (Splined)			Bushing, .707 X .788 X .591
38	401261	Miter Gear	125	170445	Kit, Filter
39	150809	Differential Shaft (310-0750)			Bottom, Filter
40	170393	Retaining Ring			Spring, Bypass
41	170394	Pin, Jackshaft			Actuator, Bypass
42	170395	Magnet, Ring			Deflector
43	170396	Spring, Bypass			Base, Filter W/ Poppet
44	150797	Bolt 3/8-24 X 2-1/2	126	170446	Kit, Fan/pulley
45	170397	Filter			Hex Jam 1/20-20 (Nylon Inset)
46	170398	Base, Filter			Washer, OD Slotted, .53 X 1.63 X .06
47	170399	Actuator, Bypass			Fan, 7 In
48	170400	Rod, Bypass Actuator			Pulley
49	196599	Arm, Bypass	127	170447	Kit, Seal
50	170402	Retaining Ring .25 External			Lip Seal .67 X 1.58 X .276
51	170403	Seal, Lip .741 X .25 X .25			Lip Seal 18 X 32 X 7
52	170404	Washer, Flat 0.050" (210-1000)			Lip Seal .706 X 1.584 X .25
53	170405	Retaining Ring			Lip Seal .741 X .250 X .250 TC
54	170406	Bearing, Center Block			Oil Seal .625 X 1.0 X .25
55	142977	Spring, Helical Compression			O-ring .07 X .301 ID
56	142978	Washer, Block Thrust	128	401266	Kit, Expansion Tank
57		20vv-50 Oil			Tank, Expansion Assembly
58	142929	Kit, Brake Yoke			Cap, Barbed Vent
59	170408	Rotor, Brake			Bolt, Self Tapping 10-32 X 1/2
60	142883	Brake Puck			Bracket, Support Expansion Tank
61	142882	Brake Puck Plate			Hose, Expansion Tank
62	170409	Pin, Brake Actuating	900	197942	Transaxle Assembly - Complete
63	170410	Hfhcs 1/4-20 X 2 W/patch, Special Flange			
64	142892	Bolt, Nylok			
65	170411	Spacer, Brake Torsion Spring			
66	401262	Spring, Brake Arm Bias			

NOTE: All Component Dimensions Given In U.S. Inches 1 Inch = 25.4 mm

REPAIR PARTS

TRACTOR - - MODEL NUMBER 944.606912

BRIGGS & STRATTON ENGINE - MODEL NUMBER 406577, TYPE NUMBER 0411-E1

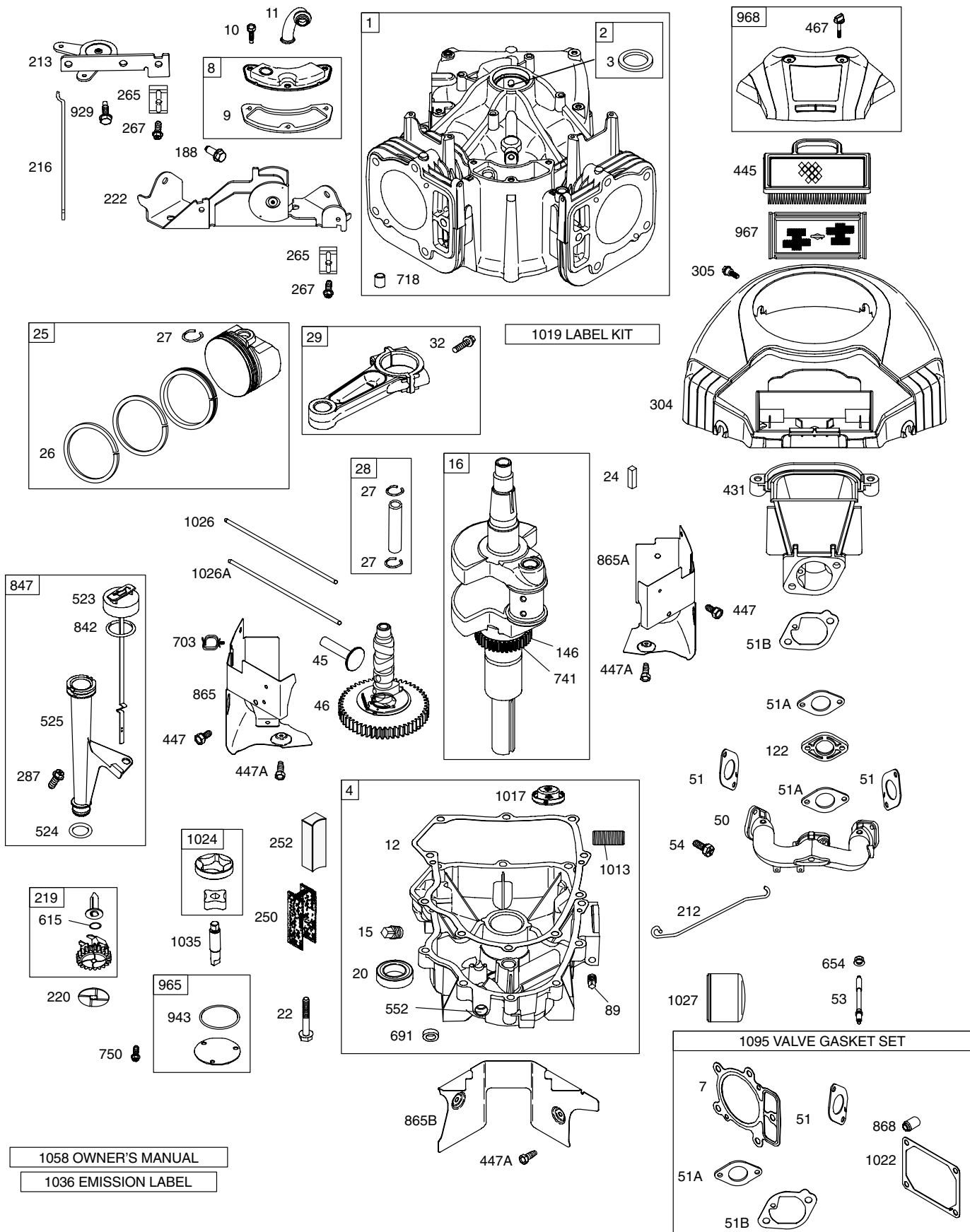

REPAIR PARTS

TRACTOR - - MODEL NUMBER 944.606912

BRIGGS & STRATTON ENGINE - MODEL NUMBER 406577, TYPE NUMBER 0411-E1

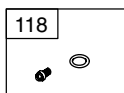
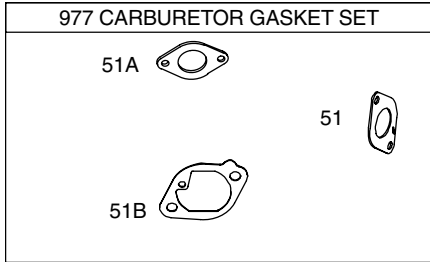
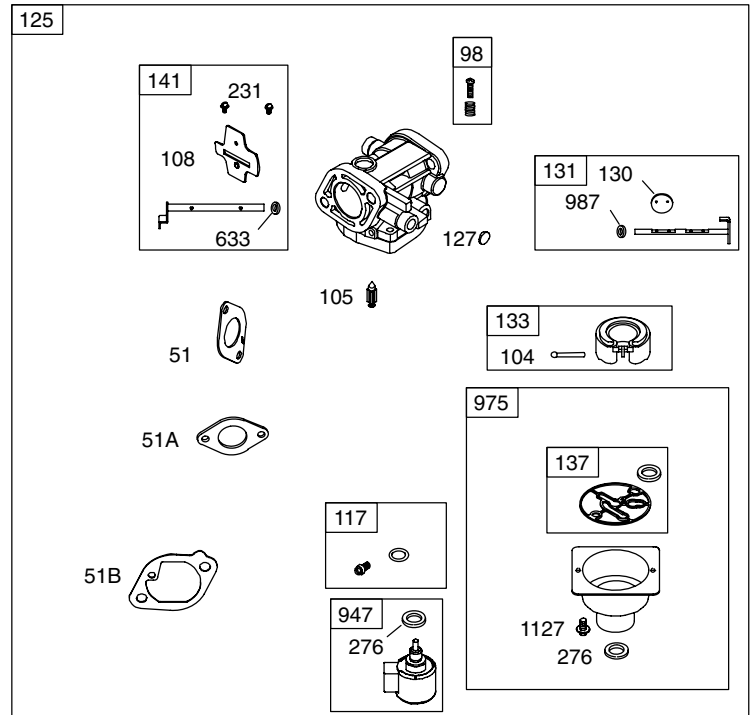
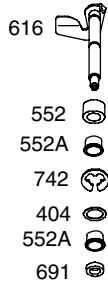
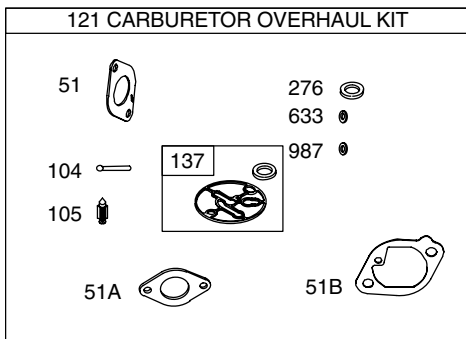
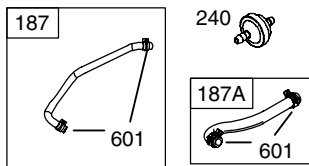
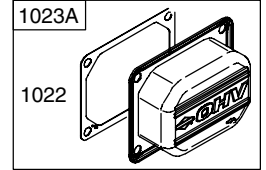
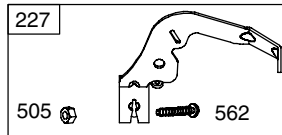
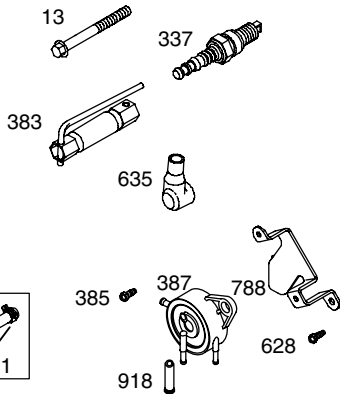
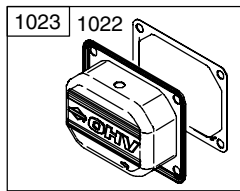
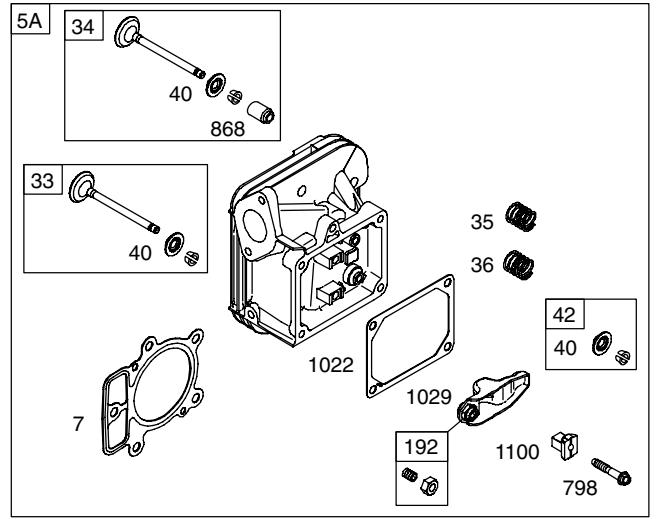
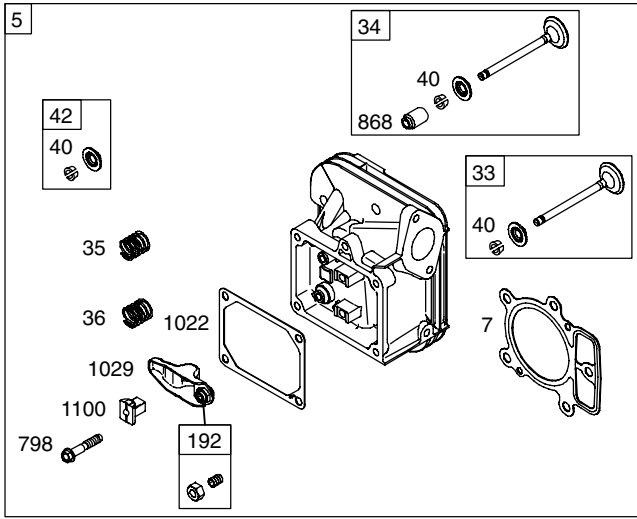

REPAIR PARTS

TRACTOR - - MODEL NUMBER 944.606912

BRIGGS & STRATTON ENGINE - MODEL NUMBER 406577, TYPE NUMBER 0411-E1

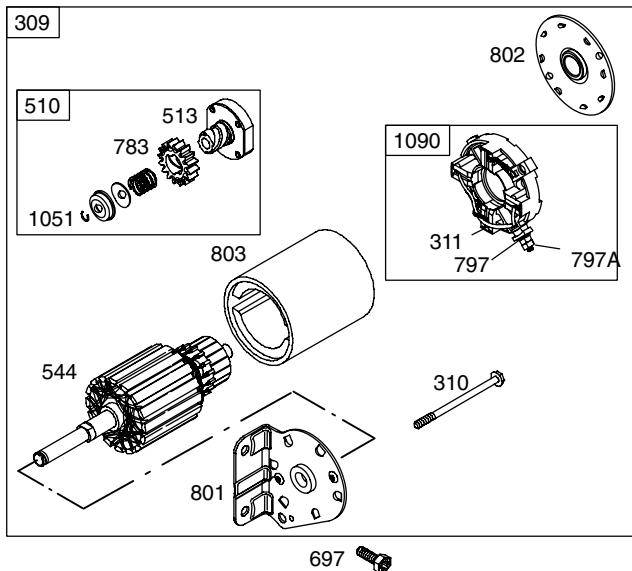
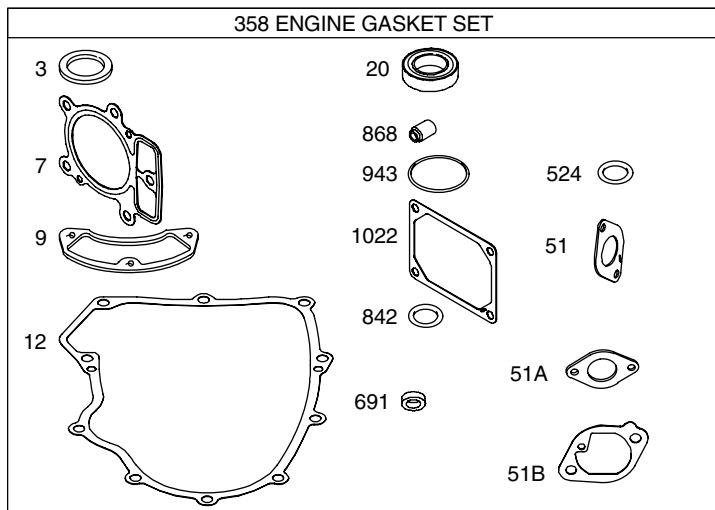
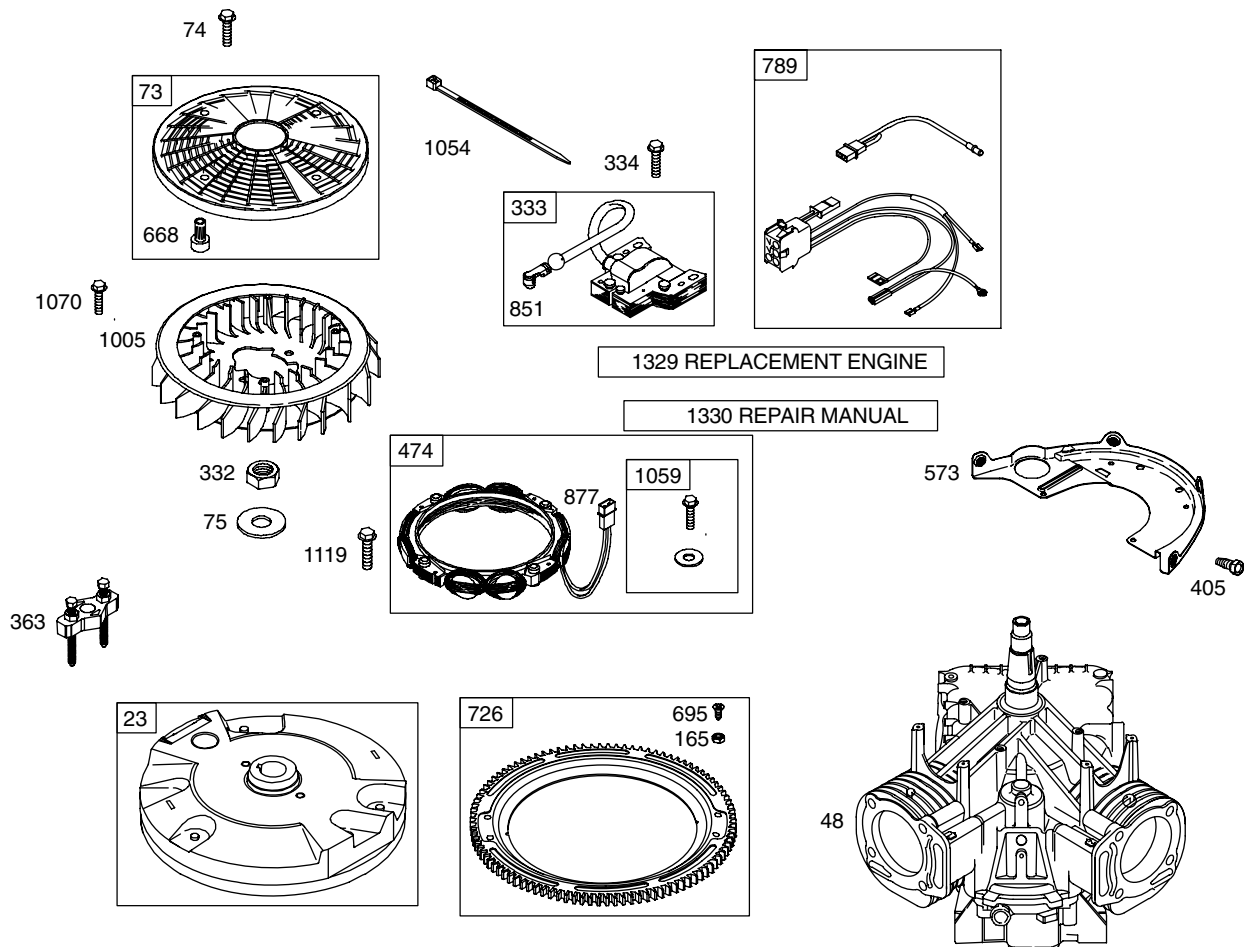

REPAIR PARTS

TRACTOR - - MODEL NUMBER 944.606912

BRIGGS & STRATTON ENGINE - MODEL NUMBER 406577, TYPE NUMBER 0411-E1

KEY NO.	PART NO.	DESCRIPTION	KEY NO.	PART NO.	DESCRIPTION
1	699751	Cylinder Assembly	130	699809	Valve-Throttle
2	499585	Kit-Bushing/Seal (Magneto Side)	131	699812	Kit-Throttle Shaft
3	391086	• Seal-Oil (Magneto Side)	133	694914	Float-Carburetor
4	699747	Sump-Engine	137	698781	∅ Gasket-Float Bowl
5	693998	Head-Cylinder (Cylinder 1)	141	699811	Kit-Choke Shaft
5A	693999	Head-Cylinder (Cylinder 2)	146	690979	Key-Timing
7	690962	•+ Gasket-Cylinder Head	165	693148	Nut (Ring Gear)
8	499601	Breather Assembly	187	699799	Line-Fuel
9	690937	• Gasket-Breather	187A	691049	Line-Fuel (Molded)
10	690960	Screw (Breather Assembly)	188	690960	Screw (Control Bracket)
11	690942	Tube-Breather	192	690083	Adjuster-Rocker Arm
12	697227	• Gasket-Crankcase	209	692909	Spring-Governor
13	690360	Screw (Cylinder Head)	211	691019	Spring-Governed Idle
15	690946	Plug-Oil Drain	212	699805	Link-Throttle
16	691046	Crankshaft	213	691021	Bracket-Choke Control
20	690947	• Seal-Oil (PTO Side)	216	691022	Link-Choke
22	694966	Screw (Engine Sump)	219	698231	Gear-Governor
23	691054	Flywheel	220	690412	Washer (Governor Lever)
24	222698	Key-Flywheel	222	698761	Bracket-Control
25	499588	Piston Assembly (Standard)	227	691048	Lever-Governor Control
25	499590	Piston Assembly (.020" Oversize)	231	690718	Screw (Choke Valve)
26	499604	Ring Set-Piston (Standard)	240	691035	Filter-Fuel
26	499606	Ring Set-Piston (.020" Oversize)	250	690957	Retainer-Breather
27	690975	Lock-Piston Pin	252	690956	Collector-Oil
28	690229	Pin-Piston	265	691024	Clamp-Casing
29	499583	Rod-Connecting	267	695134	Screw (Casing Clamp)
32	690976	Screw (Connecting Rod)	276	695410	+ Washer-Sealing
33	499596	Valve-Exhaust	287	690960	Screw (Dipstick Tube)
34	499597	Valve-Intake	304	695277	Housing-Blower
35	690963	Spring-Valve (Intake)	305	691005	Screw (Blower Housing)
36	690963	Spring-Valve (Exhaust)	309	497595	Motor-Starter
40	690964	Retainer-Valve	310	690323	Bolt (Starter Motor)
42	499586	Keeper-Valve	311	497608	Brush Set
45	690977	Tappet-Valve	332	691059	Nut (Flywheel)
46	699748	Camshaft	333	691060	Armature-Magneto
48	692714	Short Block	334	691061	Screw (Magneto Armature)
50	699801	Manifold-Intake	337	691043	Spark Plug
51	690949+• ∅‡	Gasket-Intake	358	699823	Set-Engine Gasket
51A	699803+• ∅‡	Gasket-Intake	363	691062	Flywheel Puller
51B	699800+• ∅‡	Gasket-Intake	383	690966	Wrench-Spark Plug
53	690951	Stud (Carburetor)	385	690960	Screw (Fuel Pump)
54	699816	Screw (Intake Manifold)	387	808656	Pump-Fuel
73	691055	Screen-Rotating	404	690442	Washer (Governor Crank)
74	691057	Screw (Rotating Screen)	405	697820	Screw (Back Plate)
75	691056	Washer (Flywheel)	431	699806	Elbow-Intake
89	690283	Plug-Oil	445	499486	Filter-Air Cleaner Cartridge
98	699721	Kit-Idle Speed	447	691003	Screw (Air Guide Cover)
104	694918	∅ Pin-Float Hinge	447A	690960	Screw (Air Guide Cover)
105	698537	∅ Valve-Float Needle			
108	699808	Valve-Choke			
117	698784	Jet-Main (Standard)	•		Included in Engine Gasket Set, Key. No. 358
118	699820	Jet-Main (High Altitude)	∅		Included in Carburetor Overhaul Kit, Key. No. 121
121	699814	Kit-Carburetor Overhaul	‡		Included in Carburetor Gasket Set, Key. No. 977
122	699802	Spacer-Carburetor	+		Included in Valve Gasket Set, Key. No. 1095
125	699807	Carburetor			
127	699810	Plug-Welch			

NOTE: All component dimensions given in U.S. inches 1 inch = 25.4 mm

REPAIR PARTS

TRACTOR - - MODEL NUMBER 944.606912

BRIGGS & STRATTON ENGINE - MODEL NUMBER 406577, TYPE NUMBER 0411-E1

KEY NO.	PART NO.	DESCRIPTION	KEY NO.	PART NO.	DESCRIPTION
467	691008	Knob-Air Cleaner	877	393456	Wire/Connector-Alternator
474	696459	Alternator	914	691127	Screw (Rocker Cover)
505	691029	Nut (Governor Control Lever)	918	694000	Hose-Vacuum
510	497606	Drive-Starter	929	691003	Screw (Choke Control Bracket)
513	692024	Clutch-Drive	943	690589	• Seal-O Ring (Oil Pump Cover)
523	691036	Dipstick	947	699728	Solenoid-Fuel
524	691032	• Seal-Dipstick Tube	965	499613	Cover-Oil Pump
525	691037	Tube-Dipstick	967	273638	Filter-Pre Cleaner
544	692034	Armature-Starter	968	499788	Cover-Air Cleaner
552	690552	Bushing-Governor Crank	975	699502	Bowl-Float
552A	690553	Bushing-Governor Crank	977	699815	Gasket Set-Carburetor
562	690311	Bolt (Governor Control Lever)	987	699813	Ø Seal-Throttle Shaft
573	691009	Plate-Back	1005	499603	Fan-Flywheel
601	95162	Clamp-Hose	1013	690954	Nipple-Oil Filter
615	698290	Retainer-Governor Shaft	1017	690770	Screen-Oil Pump
616	691045	Crank-Governor	1019	690103	Kit-Label
628	690960	Screw (Fuel Pump Bracket)	1022	690971	•+ Gasket-Rocker Cover
633	695414	Ø Seal-Choke/Throttle Shaft	1023	499599	Cover-Rocker (Cylinder 1)
635	66538	Boot-Spark Plug	1023A	499600	Cover-Rocker (Cylinder 2)
654	690958	Nut (Carburetor)	1024	499054	Pump-Oil
668	691215	Spacer	1026	690981	Rod-Push (Steel)
691	690657	• Seal-Governor Shaft	1026A	690982	Rod-Push (Aluminum)
695	693149	Screw (Ring Gear)	1027	492932	Filter-Oil
697	690372	Screw (Drive Cap)	1029	690972	Arm-Rocker
703	691010	Clip	1035	691042	Shaft-Pump
718	690959	Pin-Locating	1036	695704	Label-Emission
726	499612	Gear-Ring	1051	691265	Ring-Retaining
741	690980	Gear-Timing	1054	280275	Cable-Tie
742	690328	Retainer-E Ring	1058	275475	Owner's Manual
750	696999	Screw (Oil Pump Cover)	1059	698516	Kit-Screw/Washer
783	693058	Gear-Pinion	1070	691674	Screw (Flywheel Fan)
788	691039	Bracket-Fuel Pump	1090	691293	Retainer-Brush
789	698330	Harness-Wiring	1095	699822	Gasket Set-Valve
797	691029	Nut (Brush Retainer)	1100	690973	Pivot-Rocker Arm
797A	693167	Nut (Brush Retainer)	1119	691183	Screw (Alternator)
798	697890	Screw (Rocker Arm)	1127	695407	Screw (Float Bowl)
801	691283	Cap-Drive	1329	407577-0025	Replacement Engine
802	691286	Cap-End	1330	273521	Repair Manual
803	693757	Housing-Starter			
842	691031	• Seal-Dipstick/Tube	•		Included in Engine Gasket Set, Key. No. 358
847	499602	Dipstick/Tube Assembly	Ø		Included in Carburetor Overhaul Kit, Key. No. 121
851	493880	Terminal-Spark Plug	‡		Included in Carburetor Gasket Set, Key. No. 977
865	691012	Cover-Air Guide	+		Included in Valve Gasket Set, Key. No. 1095
865A	691014	Cover-Air Guide			
865B	691015	Cover-Air Guide			
868	690968	•+ Seal-Valve			

NOTE: All component dimensions given in U.S. inches 1 inch = 25.4 mm

SERVICE NOTES

SERVICE NOTES

SUGGESTED GUIDE FOR SIGHTING SLOPES FOR SAFE OPERATION

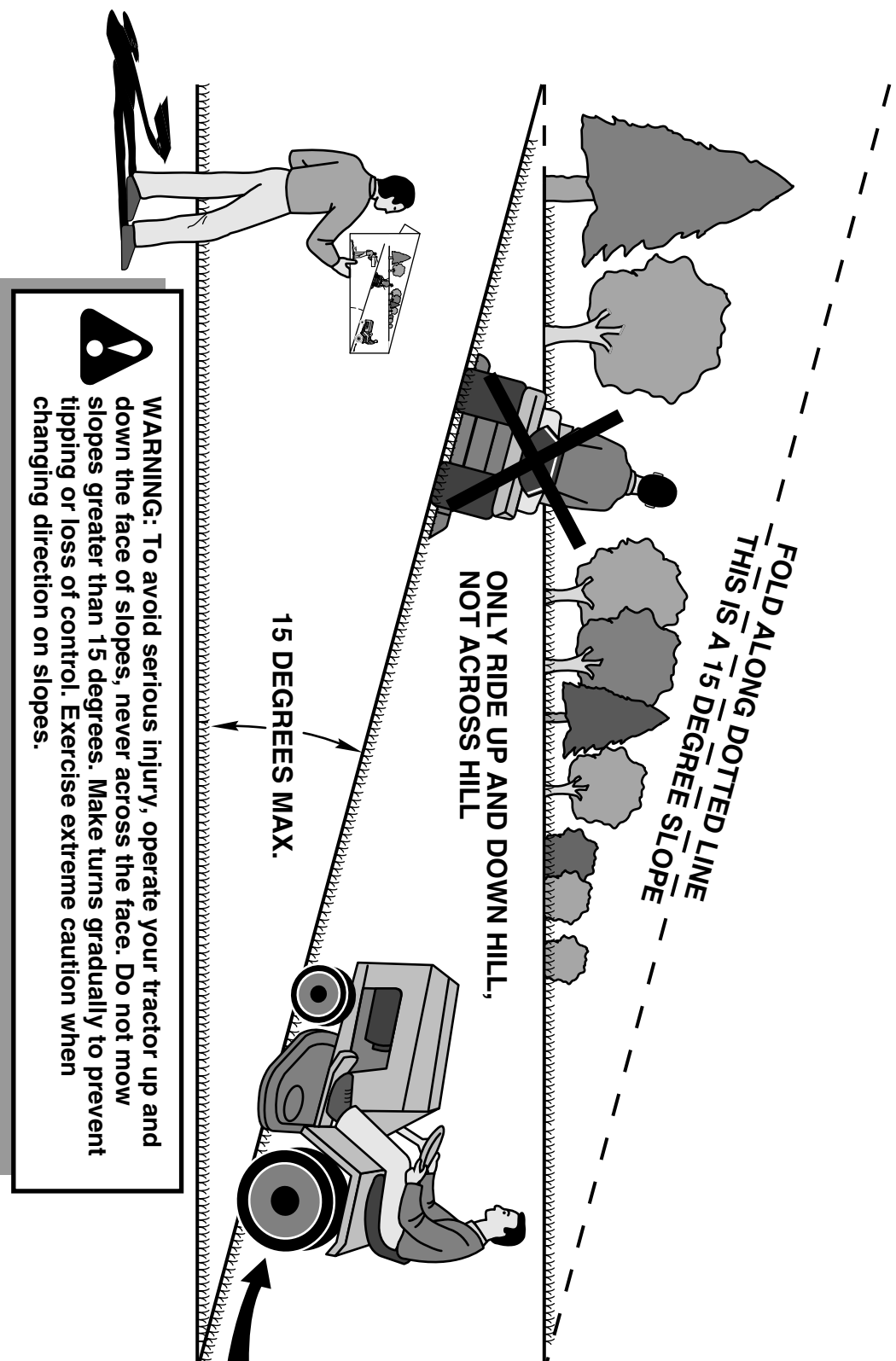

Get it fixed, at your home or ours!

Just Call:

1-800-4-MY-HOME[®]

(1-800-469-4663)

24 hours a day, 7 days a week

For the repair of major brand appliances **in your own home...**
no matter who made it, no matter who sold it!

For your nearest **Sears Parts and Service** location,
to bring in products like vacuums, lawn equipment and electronics.

For **Sears Parts & Service**, to order the replacement parts,
accessories and owner's manuals that you need to do-it-yourself.

www.sears.ca

To purchase or inquire about a Sears Maintenance Agreement, call:

1-800-361-6665

9 a.m. – 11 p.m. Mon. – Fri., EST, 9 a.m. – 4 p.m. Sat.

Pour service en français:

1-800-LE-FOYER^{MC}

(1-800-533-6937)

www.sears.ca



02488

® / TM Trademarks of Sears, Roebuck and Co. used under license by Sears Canada

MD Marque déposée / MC Marque de commerce de Sears, Roebuck and Co. utilisée en vertu d'une licence de Sears Canada