

SEARS

same as a 944.607040 and
607043

CRAFTSMAN®

MODEL NUMBER 917.258513 OWNER'S MANUAL

- Assembly
- Operation
- Customer Responsibilities
- Service and Adjustments
- Repair Parts

FILE COPY

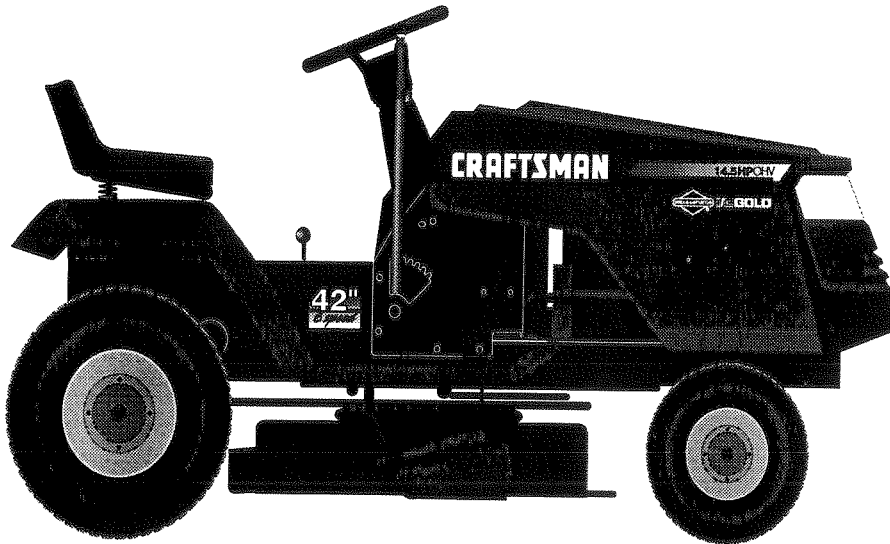

CAUTION: Read and follow all safety rules and instructions before operating this equipment.
FOR CONSUMER ASSISTANCE HOT LINE, CALL THIS TOLL FREE NUMBER: 1-800-659-5917

Sears, Roebuck and Co., Hoffman Estates, IL 60179 U.S.A.

TRACTOR -- MODEL NUMBER 917.258513

SCHEMATIC

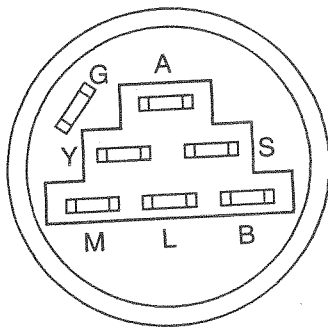
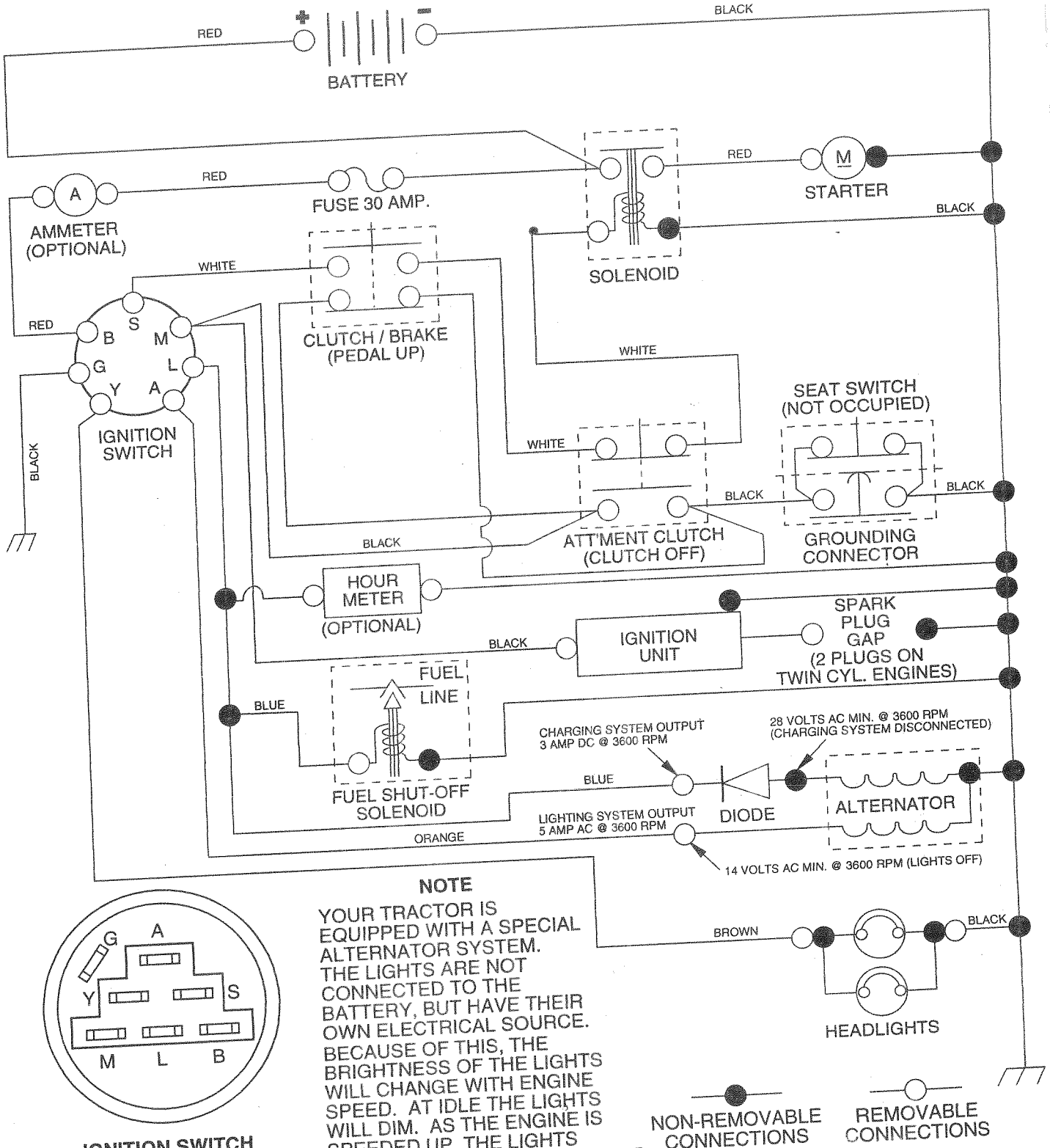

IGNITION SWITCH

POSITION	CIRCUIT	"MAKE"
OFF	G + M + L	NONE
RUN/LIGHT	B + L	A + Y
RUN	B + L	NONE
START	B + L + S	NONE

NOTE
 YOUR TRACTOR IS EQUIPPED WITH A SPECIAL ALTERNATOR SYSTEM. THE LIGHTS ARE NOT CONNECTED TO THE BATTERY, BUT HAVE THEIR OWN ELECTRICAL SOURCE. BECAUSE OF THIS, THE BRIGHTNESS OF THE LIGHTS WILL CHANGE WITH ENGINE SPEED. AT IDLE THE LIGHTS WILL DIM. AS THE ENGINE IS SPEEDED UP, THE LIGHTS WILL BECOME THEIR BRIGHTEST.

WIRING INSULATED CLIPS

NOTE: IF WIRING INSULATED CLIPS WERE REMOVED FOR SERVICING OF UNIT, THEY SHOULD BE REPLACED TO PROPERLY SECURE YOUR WIRING.

NON-REMOVABLE CONNECTIONS

REMOVABLE CONNECTIONS

REPAIR PARTS

TRACTOR - - MODEL NUMBER 917.258513

CHASSIS AND ENCLOSURES

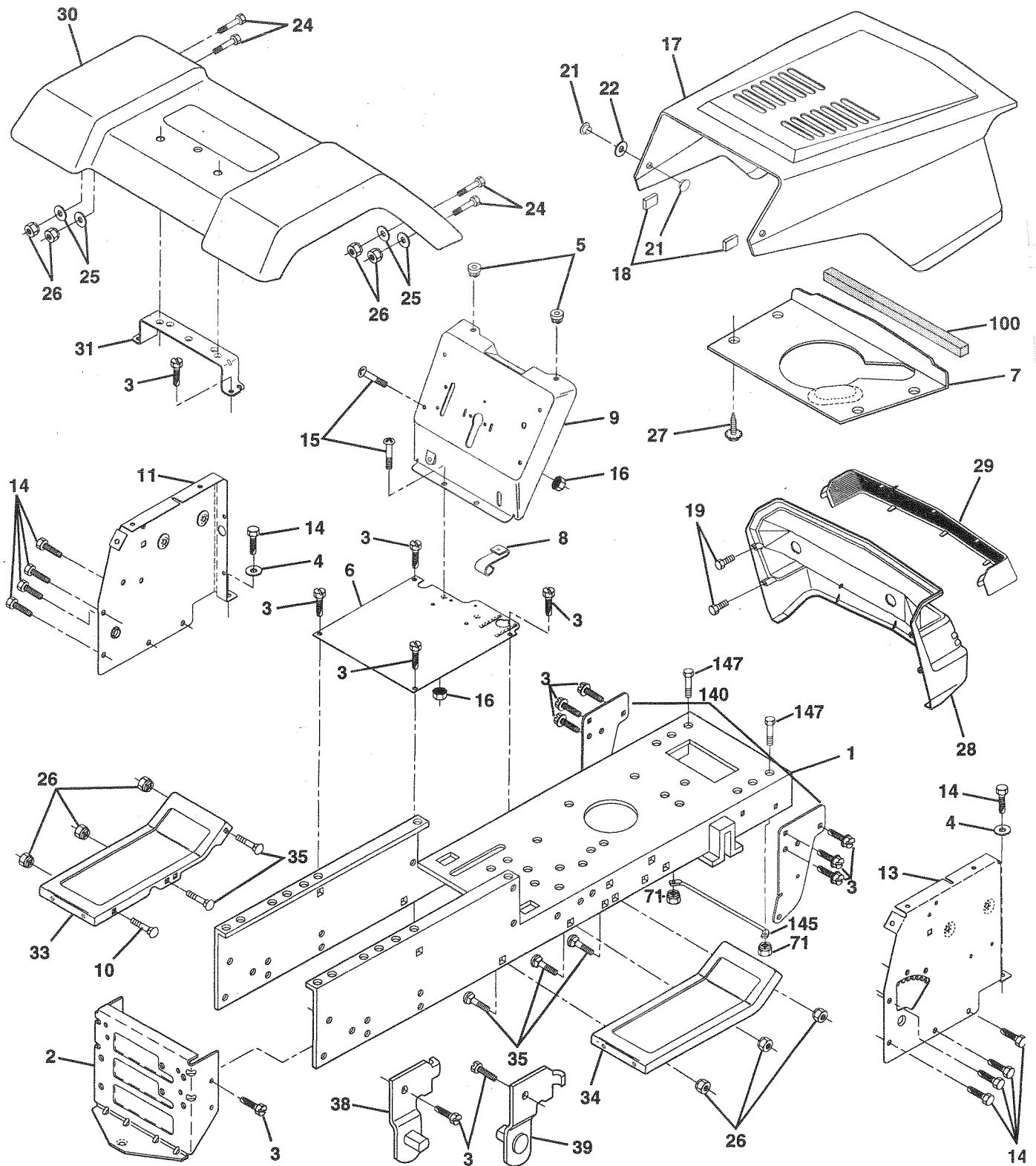

PAIR PARTS

TRACTOR - - MODEL NUMBER 917.258513

ASSIS AND ENCLOSURES

KEY NO.	PART NO.	DESCRIPTION
1	155051	Chassis Wldmt
2	140356	Drawbar Stretch
3	17490612	Screw Thdrol 3/8-16 x 3/4 Ty-tt
4	STD551025	Washer 13/32 X 3/4 X 16 Ga
5	155272	Bumper Dash Hood
6	155924X015	Saddle Slkscr Flt Lt 6sp Peerless
7	126842X	Shield Ht. Hood Kohl/Dia Engine
8	155138	Clip Retainer Slide On
9	156275X010	Dash Slkscr 1-pc
10	STD533710	Bolt Rdhd Sqnk 3/8-16unc X 1
11	146956	Panel Dash LH
13	146961X012	Panel Slkscr Dash RH
14	17490608	Screw Thdrol 3/8-16 x 1/2 Ty-tt
15	74180512	Screw Mach TRHD 5/16-18 unc x 3/4
16	STD541431	Nut Keps 5/16-18 Unc
17	154988X574	Hood Asm Pnt Slope Weld Ms-574
18	126938X	Bumper Hood
19	17521312	Screw Sltd Hex Hd W/Pl Washer
21	122933X	Rivet Ratchet Nylon
22	124479X	Washer Nylon Blk 28 x 75 x 19
24	STD523710	Bolt Fin Hex 3/8-16 unc x 1 Gr. 5
25	19131312	Washer 13/32 X 13/16 x 12 Ga
26	STD541437	Nut Hex Lock W/Ins. 3/8-16 Unc
27	17030814	Screw Spiderloc Hex Hd #8 x 7/8
28	140137	Grille Grey
29	124029X	Lens Headlight Bar Clear
30	109872X574	Fender Pnt LT W/o Shift
31	136619	Bracket Fender Repl 109873x
33	145244X574	Footrest Pnt Lh
34	145243X574	Footrest Pnt Rh
35	STD533707	Bolt Rdhd Sht Sqnk 3/8-16 x 3/4
38	139886	Bracket Asm Pvt LH MWR Rear
39	139887	Bracket Asm Pvt RH MWR Rear
71	73680400	Nut Crownlock 1/4-20 Unc
100	105037X	Strip Foam 18"
140	150556	Bracket Chassis Front 7 Ga.
145	156524	Rod Pivot Chassis/Hood
147	74760412	Bolt Hex Hd 1/4-20 Unc x 3/4
--	5479J	Plug Button Blk 359 Dia Choke

NOTE: All component dimensions given in U.S. inches
 1 inch = 25.4 mm

REPAIR PARTS

TRACTOR -- MODEL NUMBER 917.258513

DRIVE

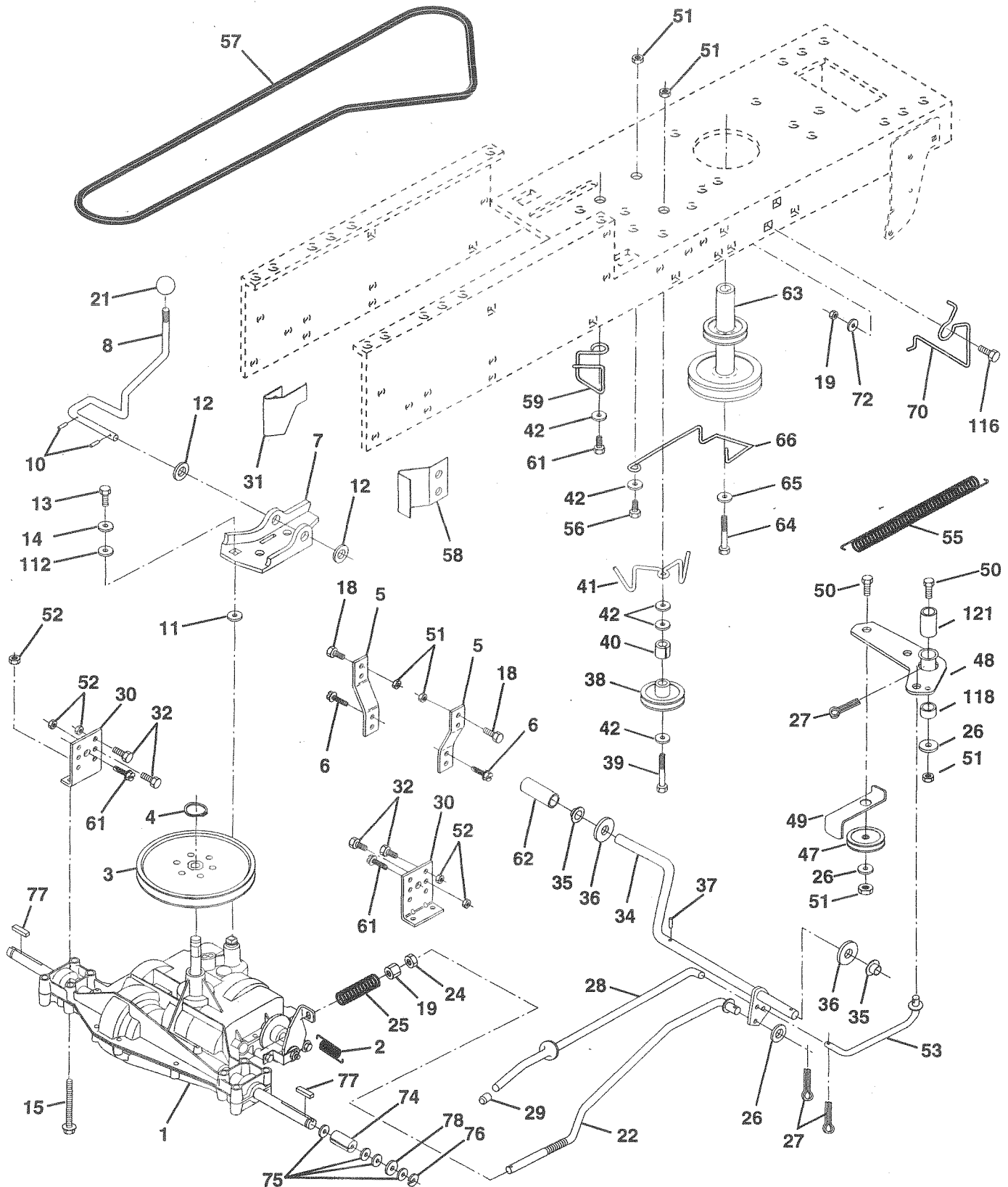

PAIR PARTS

TRACTOR - - MODEL NUMBER 917.258513

E

PART NO.	DESCRIPTION	KEY NO.	PART NO.	DESCRIPTION
-----	Transaxle (See Breakdown)	41	154777	Keeper Belt Idler
	Dana Model 4360-79	42	19131312	Washer 13/32 X 13/16 X 12 Ga
146682	Spring Return Brake T/a Zinc	47	127783	Pulley Idler V Groove Plastic
123666X	Pulley Transaxle 18/20" tires	48	154604	Bellcrank Asm Clutch
12000028	Ring Retainer # 5100-62	49	123205X	Retainer Belt Style Spring
121520X	Strap Torque 30 Degrees	50	STD523715	Bolt Hex Hd 3/8-16unc X 1-1/2
17490512	Screw Thdrol 5/16-18 X 3/4 TYT	51	STD541374	Nut Crownlock 3/8-16 UNC
130802	Bracket Saddle Shift T/a	52	STD541431	Nut Crown Lock 5/16-18
131679	Rod Shf Sdl LY/YT Str Blk Zinc	53	105710X	Link Clutch 7 66
STD561210	Pin Cotter 1/8 X 1 Cad	54	2751R	Clip Line Fuel 13/32 Mtg Hole
105701X	Washer Plate Shf 388 Sq Hole	55	105709X	Spring Return Clutch 6 75
19151216	Washer 15/32 X 3/4 X 16ga	56	STD523712	Bolt Fin Hex 3/8-16 unc x 1-1/4
74550412	Bolt 1/4-28unf Gr8 W/Patch	57	130801	V-Belt Gd Drive 95 25
STD551125	Washer Lock Hvy Helical 1/4	58	127274X	Keeper Belt RH LT Pnt/zinc 16g
74490544	Bolt Hex FLGHD5/16-18Gr.5	59	140312	Keeper Belt Centerspan
STD523710	Bolt Fin Hex	61	17490612	Screw Thdrol 3/8-16x3/4 Ty-tt
STD541437	Nut Lock Hex W/Ins. 3/8-16 Unc	62	8883R	Cover Pedal Blk Round
106933X	Knob Rd 1/2-13 Plstc Thds Blk	63	140186	Pulley Eng CI Mech 38deg LT/YT
130804	Rod Brake Blk Zinc 26 840	64	71170764	Bolt Hex 7/16-20x4 Gr 5
STD541237	Nut Hex Jam 3/8-16 Unc	65	STD551143	Washer Lock Hvy Hlcl Spr 7/16
106888X	Spring Rod Brake 2 00 Zinc	66	154778	Keeper Belt Engine
STD551037	Washer 13/32 X 13/16 X 16 Ga	70	134683	Guide Belt Mower Drive RH
STD561210	Pin Cotter 1/8 X 3/4 Cad	72	19132012	Washer 13/32 X 1-1/4 X 12 Ga
145204	Rod Brake Parking Lt/Yt	74	109502X	Spacer Axle
124236X	Cap Brake Parking Red	75	121749X	Washer 25/32 X 1 1/4 X 16 Ga
130807	Bracket Mtg Transaxle	76	STD581075	E-ring #5133-75
127275X	Keeper Belt LH LT 14 Ga	77	123583X	Key Square 2 0 X 1845/ 1865
STD523107	Bolt Hex Hd 5/16-18unc X 3/4	78	121748X	Washer 25/32 X 1-5/8 X 16ga
155071	Shaft Asm Pedal Foot	112	19091210	Washer 9/32 X 3/4 X 10 Ga
120183X	Bearing Nylon Blk 629 Id	116	72110610	Bolt Rdhd Sq Neck 3/8-16 x 1.25
STD551062	Washer 21/32 X 1 X 16 Ga	118	154774	Spacer Bellcrank
1572H	Pin Roll 3/16 X 1"	121	154419	Nyliner Clutching Stl
123674X	Pulley Idler Flat			
STD523727	Bolt Fin Hex 3/8-16unc X 2-3/4			
4470J	Spacer Split 395 X 59 Bzp			

NOTE: All component dimensions given in U.S. inches.
1 inch = 25.4 mm

REPAIR PARTS

TRACTOR - - MODEL NUMBER 917.258513

STEERING ASSEMBLY

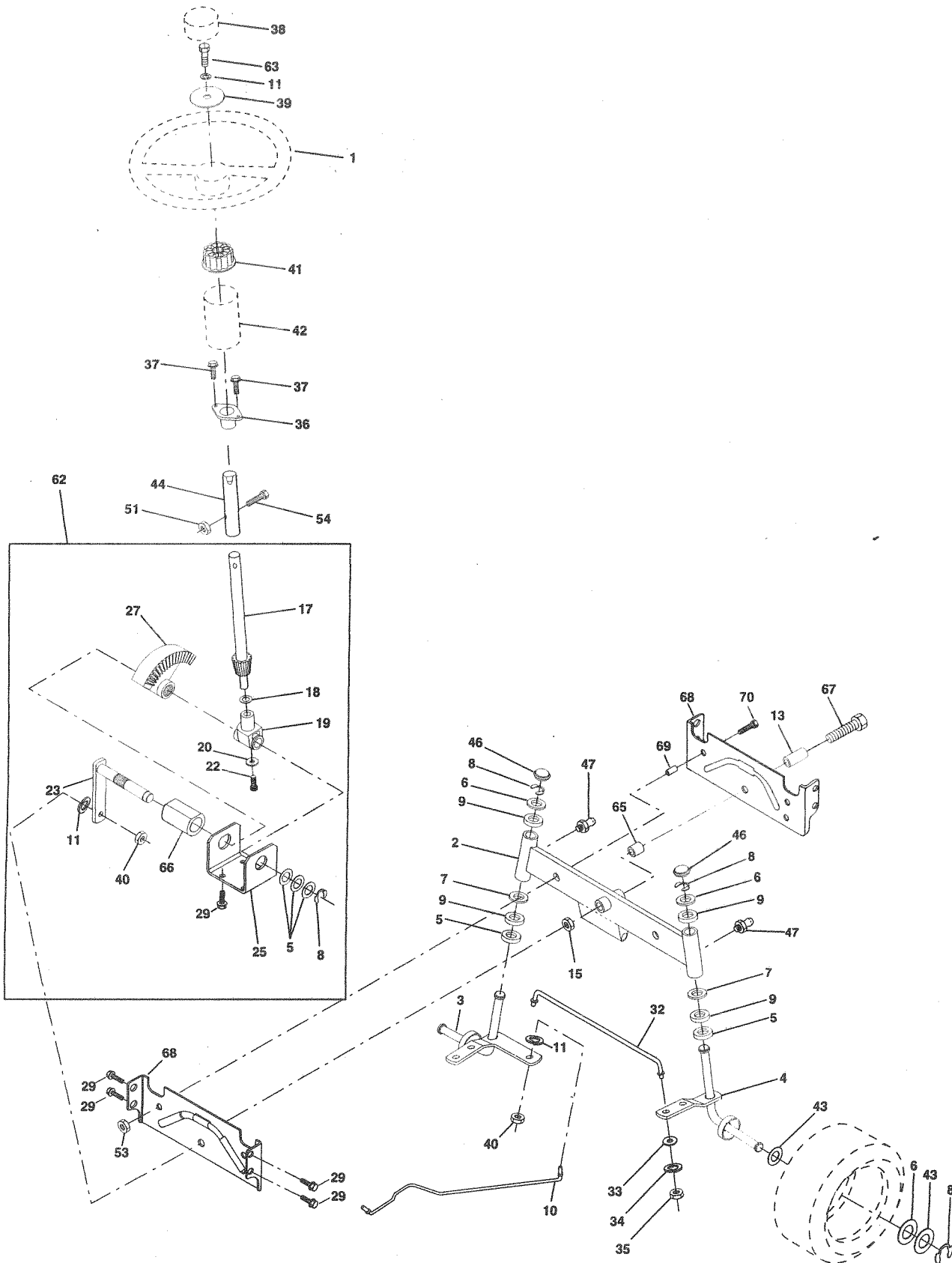

PAIR PARTS

TRACTOR -- MODEL NUMBER 917.258513

STEERING ASSEMBLY

KEY NO.	PART NO.	DESCRIPTION
1	139768	Wheel Steering Opp Sears Blk
2	154427	Axle Asm Front Lt
3	154422	Spindle Asm Lh
4	154423	Spindle Asm Rh
5	6266H	Washer Thrust .75 x 1.230
6	121748X	Washer 25/32 x 1-5/8 x 16 Ga.
7	19272016	Washer 27/32 x 1-1/4 x 16 Ga.
8	12000029	RingKlip #T5304-75
9	3366R	Bearing Col Strg Blk
10	156438	Draglink Extended Stamped
11	STD551137	Washer Lock Hvy Hlcl Spr 3/8
13	154779	Bearing Axle
15	73901000	Locknut Flange 5/8-11 UNC
17	156545	Shaft Asm Strg 5/8 x 15.19 Lt
18	57079	Washer Thrust .515 x .750 x .033
19	124035X	Support Shaft
20	126684X	Washer Shim 1/4 x 5/8 x .062
21	STD551125	Washer Lock Hvy Helical 1/4
22	71100410	Screw Cap Sckt Hd Phos & Oil
23	127501	Shaft Asm Pittman
25	154406	Bracket Steering
26	126847X	Bushing Link Drag Blk LR
27	136874	Gear Sector 22 Teeth
28	19131416	Washer 13/32 x 7/8 x 16 Ga.
29	17490612	Screw Thdrol 3/8-16 x 3/4 TY-TT
30	STD561210	Pin Cotter 1/8 x 3/4 Cad
32	130465	Rod Tie Wire Form 19.75 Mech
36	155099	Bushing Strg. 5/8 ID Dash
37	152927	Screw
38	155118	Cap Wheel Steer Opp Sears USA
39	19133808	Washer 13/32 x 2-3/8 x 8 Ga.
40	STD541537	Locknut Center 3/8-24 Unf
41	104820X	Adaptor Wheel Strg. .640/.635 Id
42	124417X	Boot Shaft Steering Craftsman
43	121749X	Washer 25/32 x 1-1/4 x 16 Ga.
46	121232X	Cap Spindle Fr Top Blk
47	6855M	Fitting Grease
51	73800500	Nut Lock Hex w/Ins. 5/16-18 Unc P
53	73680600	Nut Crownlock 3/8-16 Unc
54	74780520	Bolt Fin Hex 5/16-18 Unc P
56	19131210	Washer 13/32 x 3/4 x 10 Ga.
62	156593	Steering Assembly
63	74780616	Bolt Fin Hex 3/8-16 x 1 Gr. 5
65	154780	Spacer Axle
66	154404	Bearing Arm Pittman
67	74781044	Bolt Fin Hex 5/8-11 UNC x 2-3/4
68	154429	Brace Axle
69	160367	Spacer, Brace, Axle
70	74780636	Bolt, Fin Hex 3/8-16 Unc x 2-1/4

NOTE: All component dimensions given in U.S. inches
1 inch = 25.4 mm

REPAIR PARTS

TRACTOR - - MODEL NUMBER 917.258513

ENGINE

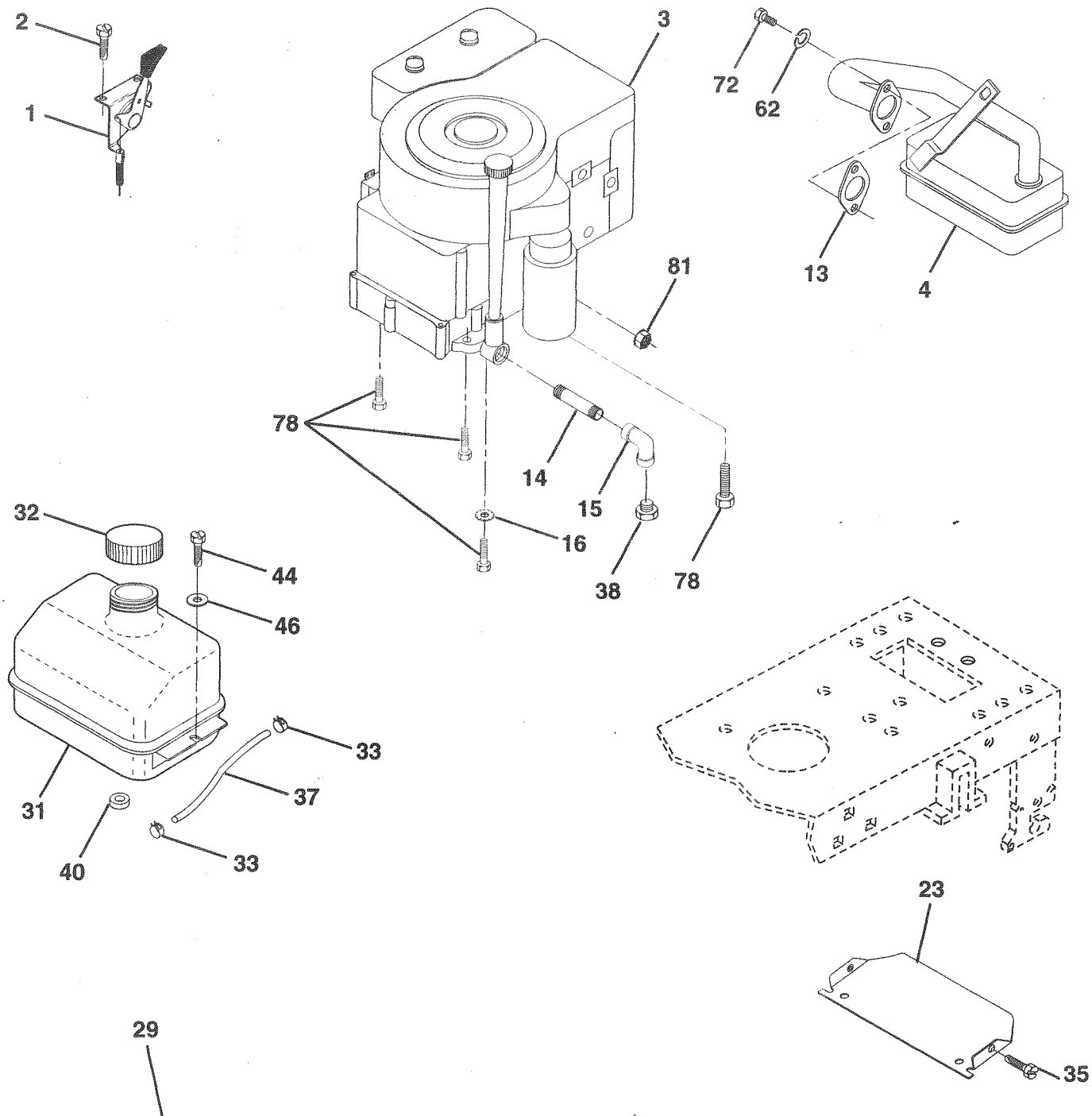

OPTIONAL EQUIPMENT
Spark Arrester

AIR PARTS

TRACTOR -- MODEL NUMBER 917.258513

E

KEY NO.	PART NO.	DESCRIPTION
1	132759	Control Th/ch RH Blk Pdl 15 10
2	17720410	Screw Hex Thd Cut 1/4-20x5/8 T
3	-----	Engine (See Breakdown)Briggs Model No 287707-0255-01
4	137352	Muffler Exh LT B&S 14HP IC OHV
13	272293	Gasket Eng 1 313 Id Tin Plated
14	13280324	Nipple Pipe 3/8 Npt x 3"
15	13200300	Elbow Std 90 Degree 3/8-18 Npt
16	STD551237	Washer Lock Ext Tooth 3/8
23	156123	Shield Browning
29	137180	Kit Spark Arrestor (Flat Scrn)
31	109202X	Tank Fuel Front 1 25
32	123549X	Cap Asm Fuel W/sym Vented
33	123487X	Clamp Hose Blk
35	17490512	Screw Thdrol 5/16-18 x 3/4 TYT
37	137040	Line Fuel 20"
38	-----	Plug Oil Drain (Order From Engine Manufacturer)
40	124028X	Bushing Snap Nyl Blk Fuel Line
44	17490412	Screw Hexwsh Thdrol 1/4-20 x 3/4
46	19091416	Washer 9/32 x 7/8 x 16 ga
62	STD551131	Washer Lock Hvy Hlcl Spr 5/16
72	71070512	Screw Hex Hd Cap 5/16-18 X 3/4
78	17490620	Screw Thdrol 3/8-16x1-1/4 TYTT
81	128861	Nut Flange 1/4-20 Starter Nut

NOTE: All component dimensions given in U.S. inches
1 inch = 25.4 mm

REPAIR PARTS

TRACTOR -- MODEL NUMBER 917.258513

SEAT ASSEMBLY

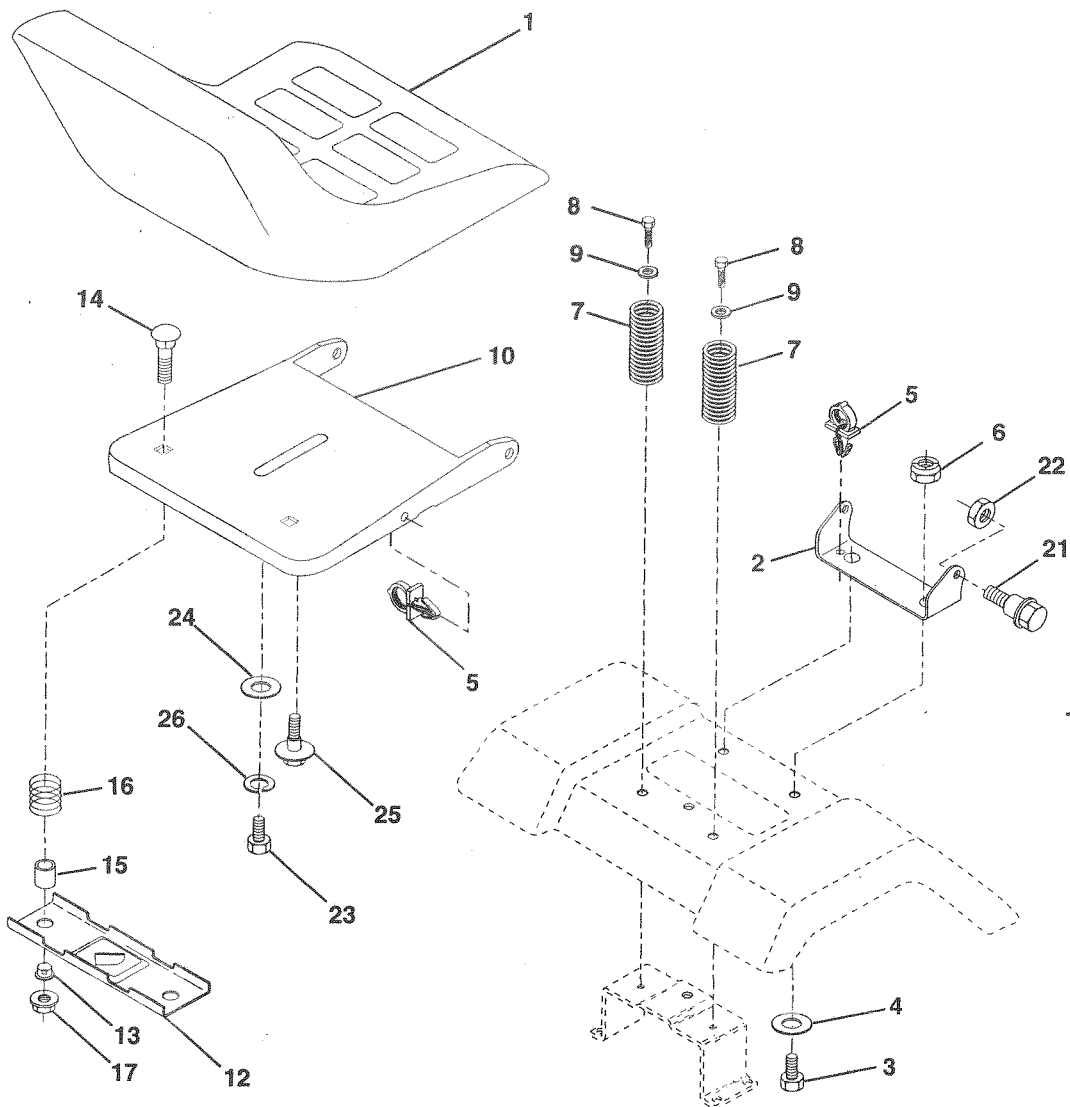

KEY NO.	PART NO.	DESCRIPTION
1	140122	Seat
2	140551	Bracket Pvt St
3	STD523710	Bolt Fin Hex 3/8-16unc X 1
4	19131610	Washer Flat 13/32 X 1 X 10 Ga
5	145006	Clip Push-In Hinged
6	STD541437	Locknut Hex W/Wsh 3/8-16
7	124181X	Spring Seat Cprsn 2 250 Blk Zi
8	17490616	Screw Thdrol 3/8-16 X 1 Ty-tt
9	19131614	Washer 13/32 X 1 X 14 Ga
10	155925	Pan Seat
12	121246X	Bracket Mounting Switch
13	121248X	Bushing Snap Blk Nyl 50 Id

KEY NO.	PART NO.	DESCRIPTION
14	72050411	Bolt Rdhd Sht Nk 1/4-20x1-3/8
15	134300	Spacer Split 28x 96 Yel Zinc
16	121250X	Spring Cprsn 1 27 Blk Pnt
17	123976X	Nut Lock 1/4 Lge Flg Gr 5 Zinc
21	153236	Bolt Shld 5/16-18 Unc
22	STD541431	Nut Lock Hex "W/Ins 5/16-18
23	74780814	Bolt Fin Hex 1/2-13 X 7/8 Gr 5
24	19171912	Washer 17/32 X 1-3/16 X 12 Ga
25	127018X	Bolt Shoulder 5/16-18 X 62
26	STD551150	Washer Lock Hvy Hlcl Spr 1/2

NOTE: All component dimensions given in U.S. inches
1 inch = 25.4 mm

AIR PARTS

TRACTOR -- MODEL NUMBER 917.258513

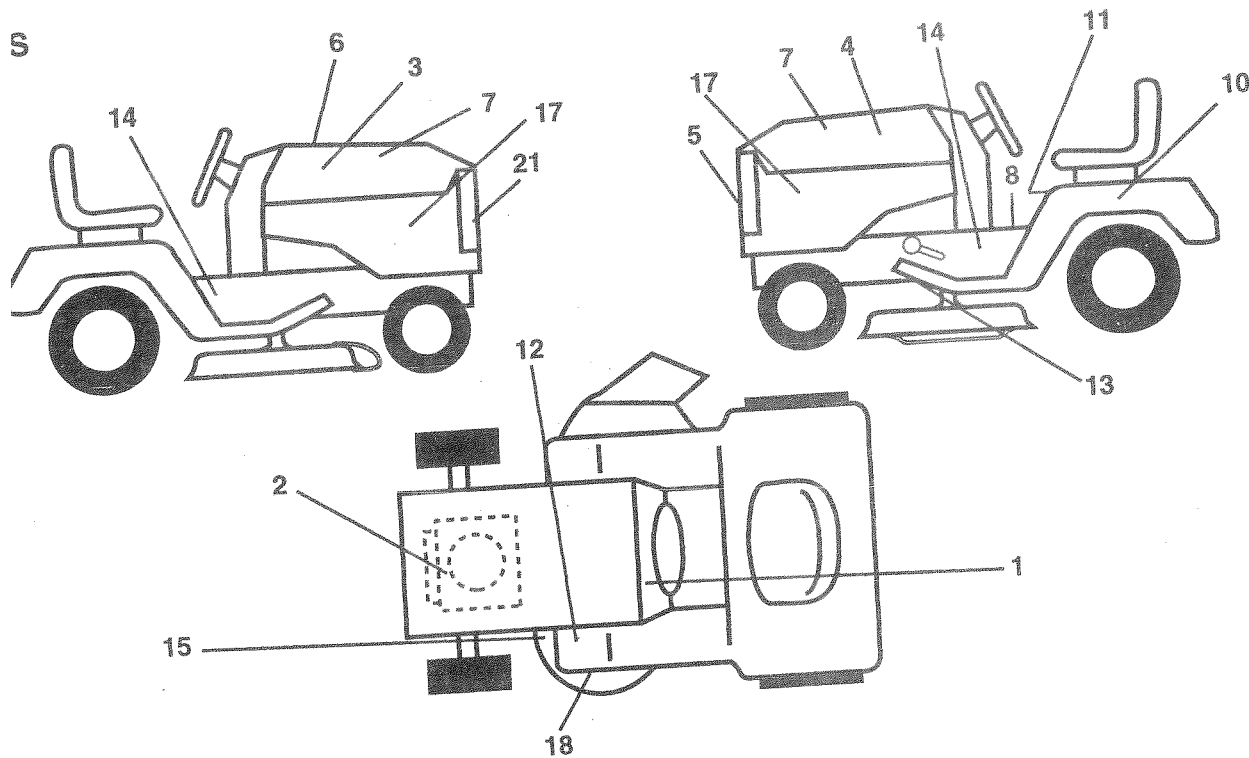

PART NO.	DESCRIPTION	KEY NO.	PART NO.	DESCRIPTION
156834	Decal Dash Inst Oper English	13	146046	Decal V-Belt Dr Sch Tractor
273504	Decal HP Engine	14	150678	Decal Chassis 6sp 42"
160302	Decal Hood RH	15	160396	Decal V-Belt Sch
160303	Decal Hood LH	17	156858	Decal Ins Hood
150680	Decal Grille Crafts	18	156787	Decal Mower EZ3 Mulch
133644	Decal Maint Cust Sears Domesti	19	150333	Decal Cap CNSMR Help Line SRS
142235	Decal Side Pnl lcgold Blk B & S	21	131265	Decal Lightbox
140837	Decal Brake Parking Saddle	--	145245	Pad Footrest
128314	Decal Fender Craftsman White	--	145247	Fastener Pop In
149516	Decal Battery Dngr/Psn Eng Acme	--	138311	Decal Handle Lft Height Adjust
156439	Decal Danger Fender Eng/span	--	160649	Manual Owners English
4900J	Decal Clutch/brake English	--	160650	Manual Owners Spanish

WHEELS & TIRES

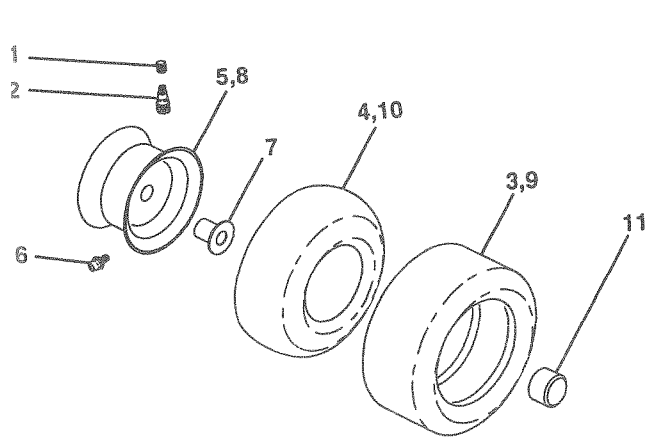

KEY NO.	PART NO.	DESCRIPTION
1	59192	Cap Valve Tire
2	65139	Stem Valve
3	106222X	Tire F Ts 15 X 6 0 - 6 Service
4	59904	Tube Front (Service Item Only)
5	106732X427	Rim Asm 6" front White Service
6	278H	Fitting Grease (Front Wheel Only)
7	9040H	Bearing Flange (Front Wheel Only)
8	106108X427	Rim Asm 8" rear white Service
9	124635X	Tire R Ts 18x8 5-8 C Service
10	7152J	Tube Rear (Service Item Only)
11	104757X	Cap Hub Axle Blk 1 50 X 1 00
--	144334	Sealant, Tire (10 oz. Tube)

NOTE: All component dimensions given in U.S. inches
1 inch = 25.4 mm

REPAIR PARTS

TRACTOR -- MODEL NUMBER 917.258513

LIFT

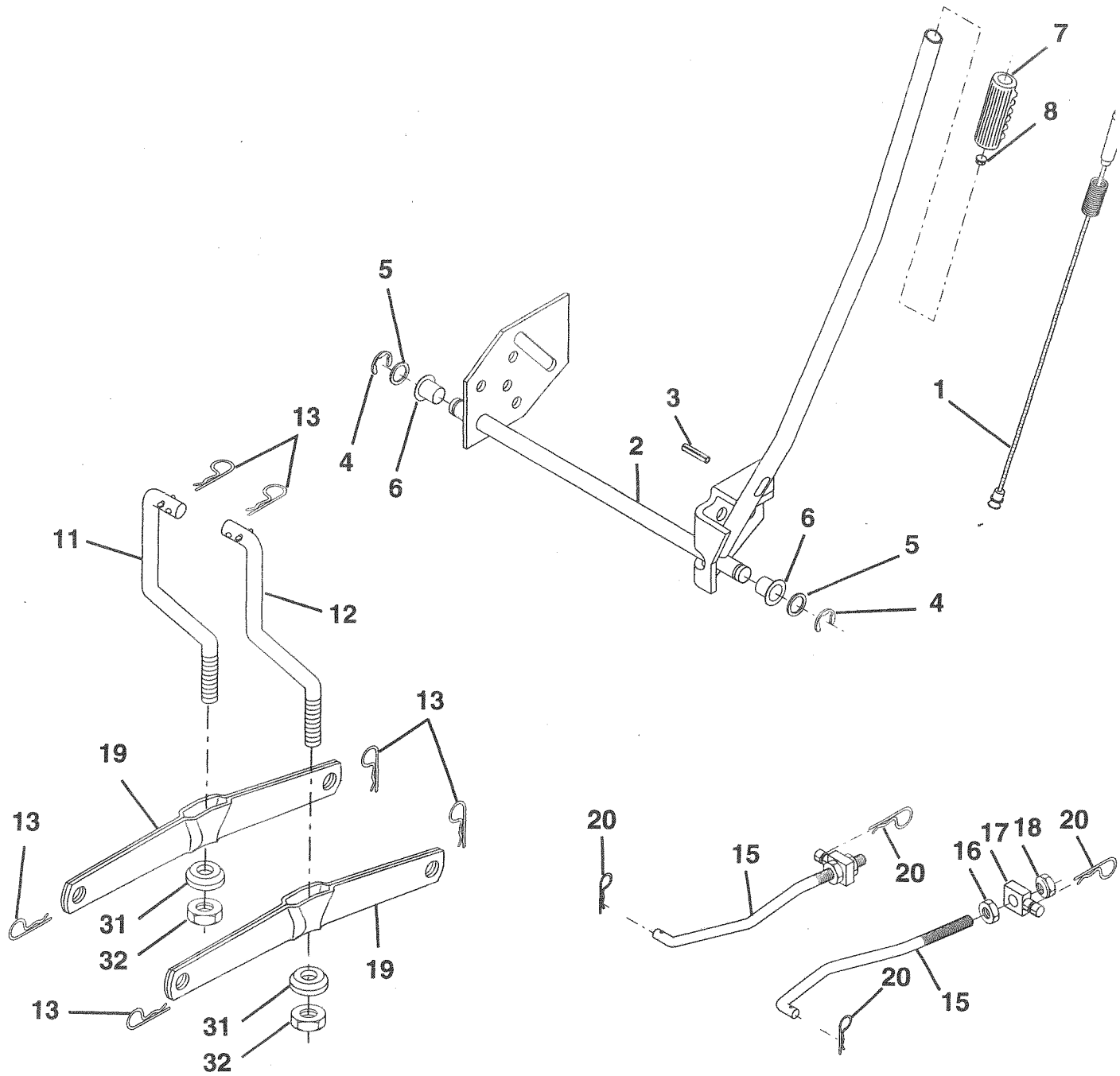

KEY NO.	PART NO.	DESCRIPTION
1	159460	Wire Asm Inner/Sprg W/plunger LT
2	159474	Shaft Asm Lift
3	105767X	Pin Groove 1 500 Zinc
4	12000002	E Ring #5133-62
5	19211621	Washer Pltd 21/32 X 1 X 21ga
6	120183X	Bearing Nylon Blk 629 Id
7	125631X	Grip Handle Fluted Blk
8	122365X	Button Plunger Red
11	139865	Link Lift LH
12	139866	Link Lift RH
13	STD624008	Retainer Spring
15	127218	Link Front
16	73350800	Nut Jam Hex 1/2-13 Unc
17	130171	Trunnion Blk Zinc
18	73800800	Nut Lock W/wsh 1/2-13unc
19	139868	Arm Suspension Rear
20	STD624008	Retainer Spring Zinc
31	140302	Bearing Pvt Lift Spherical
32	73540600	Nut Crownlock 3/8-24

NOTE: All component dimensions given in U.S. inches
 1 inch = 25.4 mm

REPAIR PARTS

TRACTOR - - MODEL NUMBER 917.258513

MOWER

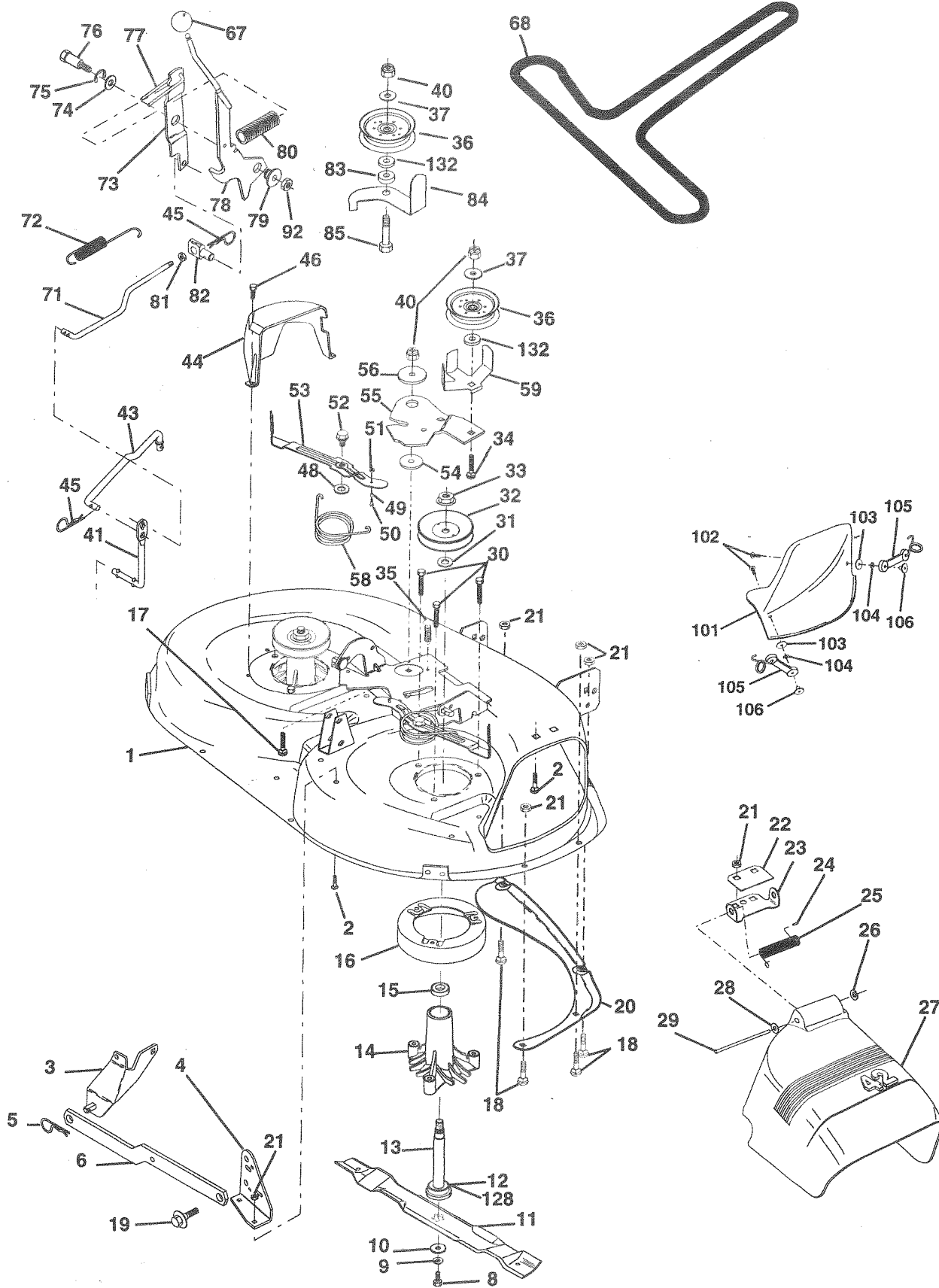

AIR PARTS

TRACTOR - - MODEL NUMBER 917.258513

OWER

PART NO.	DESCRIPTION	KEY NO.	PART NO.	DESCRIPTION
44393	Mower Housing	51	STD541410	Locknut
TD533107	Bolt	52	139888	Bolt, Shoulder 5/16-18 UNC
38017	Bracket Assembly, Sway Bar, Front	53	131845X900	Arm Assembly, Pad, Brake
38440	Bracket Assembly, Sway Bar	54	133943	Washer, Hardened
TD624008	Retainer Spring	55	155046	Arm, Idler
30832	Arm, Suspension, Rear	56	122052X	Spacer, Retainer
50857	Bolt, Hex 3/8-24 x 1.25 Grade 8	58	140086	Spring, Torsion Brakes
STD551137	Washer, Lock	59	141043	Guard, TUV Idler
40296	Washer, Hardened	67	149846	Knob Custom Oval
134149	Blade, Mulching	68	144200	V-Belt
129895	Bearing, Ball	71	142427	Rod, Clutch, Primary, with Nibs
137645	Shaft Assembly, Mandrel, Vented (Includes Key Number 6)	72	131870	Spring, Return
	Housing, Mandrel, Vented	73	127847	Arm, Clutch, Secondary
128774	Bearing, Ball, Mandrel	74	121748X	Washer 25/32 x 1-5/8 x 16 Gauge
110485X	Stripper, Vented Mower Deck	75	12000029	Ring, Klip
140329	Bolt, Carriage 3/8-16 x 1-1/4	76	128903	Bolt, Shoulder 3/8-16 UNC x 1.44
72110610	Bolt, Carriage 5/16-18 x 5/8	77	127845	Keeper, Spring
72140505	Bolt, Shoulder	78	154810	Lever Asm. Clutch Pri Plm STLT
132827	Baffle, Vortex	79	127498	Bushing, Large, Brass
136888	Nut Crownlock 5/16-18 UNC	80	153701	Spring, Mower Clutch
STD541431	Stiffener Bracket	81	73350600	Nut, Hex Jam 3/8-16 Unc
134753	Bracket, Deflector	82	142028	Trunnion, Adj.
131267	Cap, Sleeve	83	120958X	Washer Sintered
105304X	Spring, Torsion, Deflector	84	156084	Keeper Belt Idler
123713X	Nut, Push	85	72140618	Bolt Carriage 3/8-16 x 2-1/4
110452X	Shield, Deflector	92	STD541437	Nut
130968	Washer 11/32 x 5/8 x 16 Gauge	101	136420	Mulcher Cover
19111016	Rod, Hinge	102	71161010	Screw
131491	Screw Thdrol Washer Head	103	19061216	Washer #10
157722	Washer, Spacer	104	STD551110	Washer, Lock
129963	Pulley, Mandrel	105	130758	Latch Assembly, Bagger
153535	Nut, Toplock, Flanged	106	2029J	Nut, Weld
137266	Bolt	128	153390	Washer Felt
STD533717	Fastner, Christmas Tree	132	19132203	Spacer, Washer 13/32 I.D. x 1-3/8 O.D. x 1/4
133835	Pulley, Idler, Flat	--	130794	Mandrel Assembly (Includes Key Numbers 8-10, 12-15, 31 and 32)
131494	Washer 13/32 x 13/16 x 16 Gauge	--	145411	Mower Deck, Complete (Standard Deck, Order Separately Mulcher Plate and Gauge Wheel Components, Key Nos. 101-106 and 111-121)
19131316	Nut Crownlock 3/8-16 UNC			
STD541437	Rod, Pivot, with Nibs			
133551	Rod, Clutch, Secondary, with Nibs			
140083	Guard, Mandrel, L.H.			
140088	Retainer			
STD624003	Screw, Thd. Roll 1/4-20 x 5/8			
137729	Washer, Hardened			
133944	Roller Assembly, Cam Follower			
155066	Bolt, Shoulder #10-24 Grade 5			
131340				

NOTE: All component dimensions given in U.S. inches
1 inch = 25.4 mm.

REPAIR PARTS

TRACTOR - - MODEL NUMBER 917.258513

DANA TRANSAXLE - MODEL NUMBER 4360-79

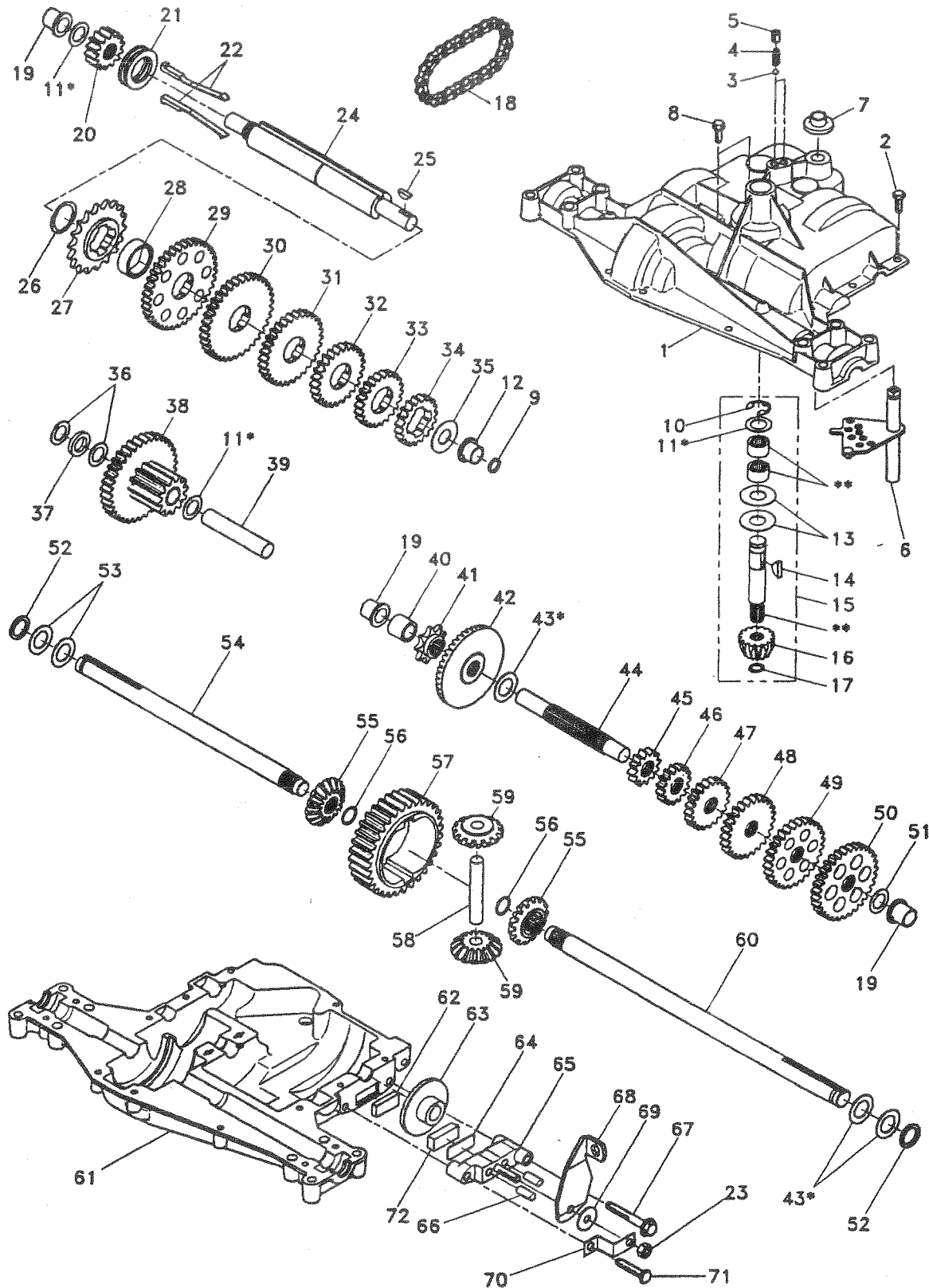

AIR PARTS

TRACTOR - - MODEL NUMBER 917.258513

TRANSAXLE - MODEL NUMBER 4360-79

RT I.	DESCRIPTION	KEY PART NO. NO.	DESCRIPTION
2671	Housing, Upper	41	Sprocket, 9 Teeth (Reverse)
74J	Screw, Self-Tapping, Large 1/4-20 x .734	42	Gear, Bevel, 42 Teeth
4400	Ball, Detent	43	* Assembly, Kit, Shim .750 Shaft
15904X	Spring, Detent	44	Shaft, Drive
15905X	Screw, Set	45	Gear, Spur, 12 Teeth (1 ^a)
18235	Kit, Shifter Assembly	46	Gear, Spur, 15 Teeth (2 ^a)
14399	Boot, Shifter	47	Gear, Spur, 20 Teeth (3 ^a)
14791	Screw, Tapping w/Sealer	48	Gear, Spur, 25 Teeth (4 ^a)
18241	Square Ring	49	Gear, Spur, 28 Teeth (5 ^a)
12672	Ring, Retaining	50	Gear, Spur, 31 Teeth (6 ^a)
14793	* Assembly, Kit, Shim .625 Shaft	51	Washer, Plain .632 x 1.00 x .060
12673	Bearing, Flange	52	Washer, Neoprene
20415X	Washer, Plain .632 x 1.38 x .046	53	Washer, Plain .758 x 1.25 x .031
12674	Key, Woodruff, #9	54	Axle, L.H.
18234	Assembly, Kit, Input Shaft	55	Gear, Miter, 15 Teeth
10078X	Pinion, Bevel, 14 Teeth	56	Ring, Retaining
05909X	Ring, Retaining	57	Gear, Spur, 32 Teeth
05910X	Chain, 24 Pitches	58	Shaft, Cross
105911X	Bearing, Flange	59	Gear, Miter, 15 Teeth
142675	Gear, Spur, 14 Teeth	60	Axle, R.H.
138246	Collar, Clutch	61	Housing, Lower
138236	Assembly, Kit, Clutch Keys	62	Puck, Friction
73810500	Locknut 5/16-24	63	Disc, Brake
142676	Shaft, Intermediate	64	Spacer
2244J	Key, Woodruff, #61	65	Jaw, Brake
105916X	Ring, Retaining	66	Pin, Dowel
120470X	Sprocket, 18 Teeth (Reverse)	67	Screw, Self-Tapping, Large 5/16-18 x 2.25
110070X	Spacer	68	Lever, Actuating
142677	Gear, Spur, 37 Teeth (1 ^a)	69	Washer, Plain .321 x 1.00 x .055
142681	Gear, Spur, 35 Teeth (2 ^a)	70	Bracket, Anti-Rotation
120405X	Gear, Spur, 30 Teeth (3 ^a)	71	Screw, Self-Tapping, Large 5/16-18 x 1.44
108980X	Gear, Spur, 25 Teeth (4 ^a)	72	Puck, Friction
120406X	Gear, Spur, 22 Teeth (5 ^a)	73	Grease
134796	Gear, Spur, 19 Teeth (6 ^a)		
105925X	Washer, Plain .640 x 1.37 x .061		
2232J	Washer, Plain .632 x 1.00 x .026		
108978X	Spacer .630 x 1.00 x .169		
110079X	Assembly, Gear, Combination of 12 Teeth and 35 Teeth		
124639X	Shaft, Idler		
120472X	Spacer .635 x .875 x .755		

* Use in combinations to maintain proper clearances

** Order Key No. 15

NOTE: All component dimensions given in U.S. inches
1 inch = 25.4 mm