

SEARS
OWNER'S
MANUAL

MODEL NO.
944.607930

Important:
Read and follow
all Safety Rules
and Instructions
Before Operating
This Equipment



CRAFTSMAN®

20.0 HP*
ELECTRIC START
42" MOWER
AUTOMATIC TRANSMISSION
LAWN TRACTOR

- Assembly
- Operation
- Maintenance
- Service and Adjustments
- Repair Parts

*As rated by the engine manufacturer

Sears Canada, Inc., Toronto, Ontario M5B 2B8



SAFETY RULES



Safe Operation Practices for Ride-On Mowers

DANGER: THIS CUTTING MACHINE IS CAPABLE OF AMPUTATING HANDS AND FEET AND THROWING OBJECTS. FAILURE TO OBSERVE THE FOLLOWING SAFETY INSTRUCTIONS COULD RESULT IN SERIOUS INJURY OR DEATH.



WARNING: In order to prevent accidental starting when setting up, transporting, adjusting or making repairs, always disconnect spark plug wire and place wire where it cannot contact spark plug.



WARNING: Do not coast down a hill in neutral, you may lose control of the tractor.



WARNING: Tow only the attachments that are recommended by and comply with specifications of the manufacturer of your tractor. Use common sense when towing. Operate only at the lowest possible speed when on a slope. Too heavy of a load, while on a slope, is dangerous. Tires can lose traction with the ground and cause you to lose control of your tractor.

I. GENERAL OPERATION

- Read, understand, and follow all instructions on the machine and in the manual before starting.
- Do not put hands or feet near rotating parts or under the machine. Keep clear of the discharge opening at all times.
- Only allow responsible adults, who are familiar with the instructions, to operate the machine.
- Clear the area of objects such as rocks, toys, wire, etc., which could be picked up and thrown by the blades.
- Be sure the area is clear of bystanders before operating. Stop machine if anyone enters the area.
- Never carry passengers.
- Do not mow in reverse unless absolutely necessary. Always look down and behind before and while backing.
- Never direct discharged material toward anyone. Avoid discharging material against a wall or obstruction. Material may ricochet back toward the operator. Stop the blades when crossing gravel surfaces.
- Do not operate machine without the entire grass catcher, discharge guard, or other safety devices in place and working.
- Slow down before turning.
- Never leave a running machine unattended. Always turn off blades, set parking brake, stop engine, and remove keys before dismounting.
- Disengage blades when not mowing. Shut off engine and wait for all parts to come to a complete stop before cleaning the machine, removing the grass catcher, or unclogging the discharge guard.
- Operate machine only in daylight or good artificial light.
- Do not operate the machine while under the influence of alcohol or drugs.
- Watch for traffic when operating near or crossing roadways.
- Use extra care when loading or unloading the machine into a trailer or truck.
- Always wear eye protection when operating machine.

- Data indicates that operators, age 60 years and above, are involved in a large percentage of riding mower-related injuries. These operators should evaluate their ability to operate the riding mower safely enough to protect themselves and others from serious injury.
- Follow the manufacturer's recommendation for wheel weights or counterweights.
- Keep machine free of grass, leaves or other debris build-up which can touch hot exhaust / engine parts and burn. Do not allow the mower deck to plow leaves or other debris which can cause build-up to occur. Clean any oil or fuel spillage before operating or storing the machine. Allow machine to cool before storage.

II. SLOPE OPERATION

Slopes are a major factor related to loss of control and tip-over accidents, which can result in severe injury or death. Operation on all slopes requires extra caution. If you cannot back up the slope or if you feel uneasy on it, do not mow it.

- Mow up and down slopes, not across.
- Watch for holes, ruts, bumps, rocks, or other hidden objects. Uneven terrain could overturn the machine. Tall grass can hide obstacles.
- Choose a low ground speed so that you will not have to stop or shift while on the slope.
- Do not mow on wet grass. Tires may lose traction. Always keep the machine in gear when going down slopes. Do not shift to neutral and coast downhill.
- Avoid starting, stopping, or turning on a slope. If the tires lose traction, disengage the blades and proceed slowly straight down the slope.
- Keep all movement on the slopes slow and gradual. Do not make sudden changes in speed or direction, which could cause the machine to roll over.
- Use extra care while operating machine with grass catchers or other attachments; they can affect the stability of the machine. Do no use on steep slopes.
- Do not try to stabilize the machine by putting your foot on the ground.
- Do not mow near drop-offs, ditches, or embankments. The machine could suddenly roll over if a wheel is over the edge or if the edge caves in.

III. CHILDREN

Tragic accidents can occur if the operator is not alert to the presence of children. Children are often attracted to the machine and the mowing activity. *Never* assume that children will remain where you last saw them.

- Keep children out of the mowing area and in the watchful care of a responsible adult other than the operator.
- Be alert and turn machine off if a child enters the area.
- Before and while backing, look behind and down for small children.
- Never carry children, even with the blades shut off. They may fall off and be seriously injured or interfere with safe machine operation. Children who have been given rides in the past may suddenly appear in the mowing area for another ride and be run over or backed over by the machine.
- Never allow children to operate the machine.
- Use extra care when approaching blind corners, shrubs, trees, or other objects that may block your view of a child.



SAFETY RULES

Safe Operation Practices for Ride-On Mowers



IV. TOWING

- Tow only with a machine that has a hitch designed for towing. Do not attach towed equipment except at the hitch point.
- Follow the manufacturer's recommendation for weight limits for towed equipment and towing on slopes.
- Never allow children or others in or on towed equipment.
- On slopes, the weight of the towed equipment may cause loss of traction and loss of control.
- Travel slowly and allow extra distance to stop.

V. SERVICE

SAFE HANDLING OF GASOLINE

To avoid personal injury or property damage, use extreme care in handling gasoline. Gasoline is extremely flammable and the vapors are explosive.

- Extinguish all cigarettes, cigars, pipes, and other sources of ignition.
- Use only approved gasoline container.
- Never remove gas cap or add fuel with the engine running. Allow engine to cool before refueling.
- Never fuel the machine indoors.
- Never store the machine or fuel container where there is an open flame, spark, or pilot light such as on a water heater or other appliances.
- Never fill containers inside a vehicle or on a truck or trailer bed with plastic liner. Always place containers on the ground away from your vehicle when filling.
- Remove gas-powered equipment from the truck or trailer and refuel it on the ground. If this is not possible, then refuel such equipment with a portable container, rather than from a gasoline dispenser nozzle.
- Keep the nozzle in contact with the rim of the fuel tank or container opening at all times until fueling is complete. Do not use a nozzle lock-open device.
- If fuel is spilled on clothing, change clothing immediately.
- Never overfill fuel tank. Replace gas cap and tighten securely.

GENERAL SERVICE

- Never operate machine in a closed area.
- Keep all nuts and bolts tight to be sure the equipment is in safe working condition.
- Never tamper with safety devices. Check their proper operation regularly.
- Keep machine free of grass, leaves, or other debris build-up. Clean oil or fuel spillage and remove any fuel-soaked debris. Allow machine to cool before storing.
- If you strike a foreign object, stop and inspect the machine. Repair, if necessary, before restarting.

- Never make any adjustments or repairs with the engine running.
- Check grass catcher components and the discharge guard frequently and replace with manufacturer's recommended parts, when necessary.
- Mower blades are sharp. Wrap the blade or wear gloves, and use extra caution when servicing them.
- Check brake operation frequently. Adjust and service as required.
- Maintain or replace safety and instruction labels, as necessary.



- Be sure the area is clear of bystanders before operating. Stop machine if anyone enters the area.
- Never carry passengers.
- Do not mow in reverse unless absolutely necessary. Always look down and behind before and while backing.
- Never carry children, even with the blades shut off. They may fall off and be seriously injured or interfere with safe machine operation. Children who have been given rides in the past may suddenly appear in the mowing area for another ride and be run over or backed over by the machine.
- Keep children out of the mowing area and in the watchful care of a responsible adult other than the operator.
- Be alert and turn machine off if a child enters the area.
- Before and while backing, look behind and down for small children.
- Mow up and down slopes (15° Max), not across.
- Choose a low ground speed so that you will not have to stop or shift while on the slope.
- Avoid starting, stopping, or turning on a slope. If the tires lose traction, disengage the blades and proceed slowly straight down the slope.
- If machine stops while going uphill, disengage blades, shift into reverse and back down slowly.
- Do not turn on slopes unless necessary, and then, turn slowly and gradually downhill, if possible.

TABLE OF CONTENTS

SAFETY RULES	2-3
PRODUCT SPECIFICATIONS.....	4
CUSTOMER RESPONSIBILITIES.....	4
WARRANTY.....	4
ASSEMBLY.....	5-8
OPERATION	9-15
MAINTENANCE SCHEDULE	16

MAINTENANCE.....	16-19
SERVICE AND ADJUSTMENTS	20-25
STORAGE.....	26
TROUBLESHOOTING.....	27-28
REPAIR PARTS - TRACTOR	30-45
REPAIR PARTS - ENGINE	46-49
PARTS ORDERING/SERVICE	BACK COVER

PRODUCT SPECIFICATIONS

Gasoline Capacity and type:	1.50 Gallons Unleaded Regular
Oil Type (API-SG-SL):	SAE 30 (above 32°F) SAE 5W-30 (below 32°F) Synthetic (below 0°F)
Your tractor was shipped from the factory with non-synthetic SAE 10W30 motor oil	
Oil Capacity:	W/Filter: 56 oz W/O Filter: 48 oz
Spark Plug:	Champion RC12YC (Gap: .030")
Ground Speed (MPH):	Forward: 0-5.5 Reverse: 0-2.4
Charging System:	3 Amps Battery 5 Amps Headlights
Battery:	AMP/HR: 28 Min. CCA: 280
Case Size:	U1R
Blade Bolt Torque:	45-55 FT. LBS.

CONGRATULATIONS on your purchase of a new Tractor. It has been designed, engineered and manufactured to give you the best possible dependability and performance.

Should you experience any problem you cannot easily remedy, please contact your nearest authorized service center/department. We have competent, well-trained representatives and the proper tools to service or repair this tractor.

Please read and retain this manual. The instructions will enable you to assemble and maintain your tractor properly. Always observe the "SAFETY RULES".

MAINTENANCE AGREEMENT

A Maintenance Agreement is available on this product. Contact your nearest Sears store for details.

CUSTOMER RESPONSIBILITIES

- Read and observe the safety rules.
- Follow a regular schedule in maintaining, caring for and using your tractor.
- Follow the instructions under "Maintenance" and "Storage" sections of this owner's manual.

WARNING: This tractor is equipped with an internal combustion engine and should not be used on or near any unimproved forest-covered, brush-covered or grass-covered land unless the engine's exhaust system is equipped with a spark arrester meeting applicable local or state laws (if any). If a spark arrester is used, it should be maintained in effective working order by the operator.

A spark arrester for the muffler is available through your nearest authorized service center/department (See REPAIR PARTS section of this manual).

LIMITED TWO (2) YEAR WARRANTY ON CRAFTSMAN TRACTOR (RIDING EQUIPMENT)

For two (2) years from date of purchase Sears Canada, Inc. will repair or replace at Sears option free of charge parts which are defective as a result of material or workmanship.

FULL ONE (1) YEAR WARRANTY ON BATTERY

For one (1) year from date of purchase, if any battery included with this riding equipment proves defective in material or workmanship and our testing determines the battery will not hold a charge, Sears will replace the battery at no charge.

COMMERCIAL OR RENTAL USE

Warranty on Riding Equipment used for commercial or rental purposes is limited to ninety (90) days.

This Warranty does NOT cover:

1. Pre-delivery set-up.
2. Tire replacement or repair caused by punctures from outside objects (such as nails, thorns, stumps, or glass).
3. Expendable items which become worn during normal use, such as blades, spark plug, air cleaners and belts.
4. Repairs necessary because of operator abuse or negligence, including damaged jackshaft or mandrel and the failure to operate and maintain the equipment according to the instructions contained in the Owner's Manual.

Warranty service is available by returning the Craftsman Riding Equipment to the nearest Sears Service Centre/Department in Canada. This warranty applies only while this product is in use in Canada.

This warranty is in addition to any statutory warranty and does not exclude or limit legal rights you may have but shall run concurrently with applicable provincial legislation. Furthermore, some provinces do NOT allow limitation on how long an implied warranty will last so the above limitations may not apply to you.

SEARS CANADA, INC., TORONTO, ONTARIO M5B 2B8

UNASSEMBLED PARTS

Steering Wheel

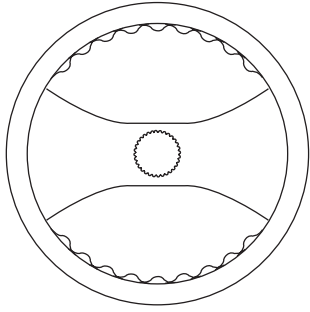

Steering Boot



Steering Extension Shaft

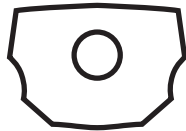

Insert



Steering Wheel Adapter

(1) Large Flat Washer

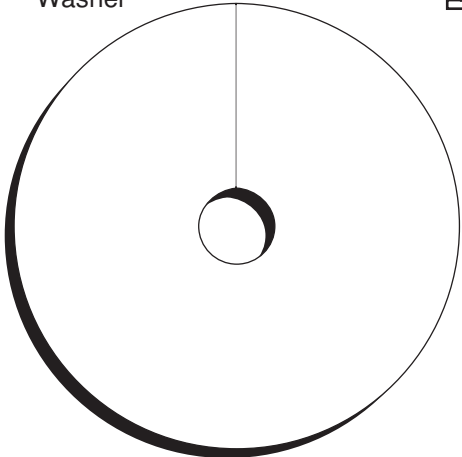

(1) Large Flat Washer



(1) 5/16 Lock Washer

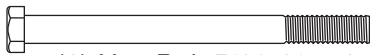

(1) Hex Bolt 5/16-18 x 4

Seat

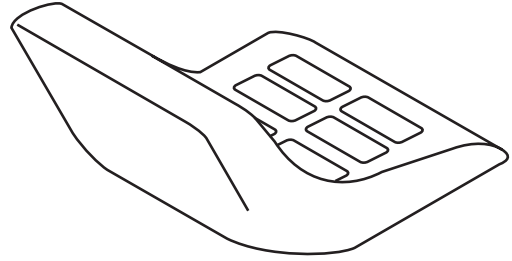

(1) Cup Washer
17/32 x 1-3/16 x 12 Gauge



(1) Knob

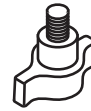

Battery

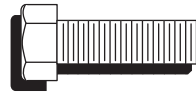

(2) Hex Bolts 1/4-20 x 3/4

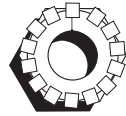

(2) Keps Nuts 1/4-20



(1) Oil Drain Tube

Keys

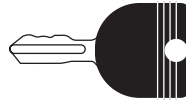

(2) Keys

Slope Sheet

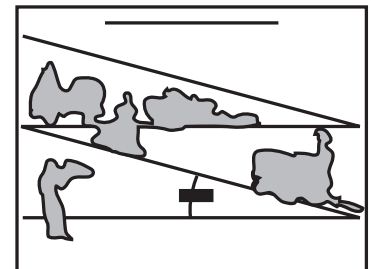

ASSEMBLY

Your new tractor has been assembled at the factory with the exception of those parts left unassembled for shipping purposes.

TOOLS REQUIRED FOR ASSEMBLY

A socket wrench set will make assembly easier. Standard wrench sizes are listed.

(2) 7/16" wrenches

When right or left hand is mentioned in this manual, it means when you are in the operating position (seated behind the steering wheel).

TO REMOVE TRACTOR FROM CARTON

UNPACK CARTON

- Remove all accessible loose parts and parts cartons from carton.
- Cut along dashed lines on all four panels of carton. Remove end panels and lay side panels flat.
- Check for any additional loose parts or cartons and remove.

BEFORE REMOVING TRACTOR FROM SKID

ATTACH STEERING WHEEL (See Fig. 1)

- Remove locknut and large flat washer from steering shaft.
- Position front wheels of the tractor so they are pointing straight forward.
- Slide the steering sleeve over the steering shaft.
- Position steering wheel so cross bars are horizontal (left to right) and slide onto steering wheel adapter.
- Secure steering wheel to steering shaft with locknut and large flat washer previously removed. Tighten securely.
- Snap steering wheel insert into center of steering wheel.
- Remove protective materials from tractor hood and grill.

IMPORTANT: CHECK FOR AND REMOVE ANY STAPLES IN SKID THAT MAY PUNCTURE TIRES WHERE TRACTOR IS TO ROLL OFF SKID.

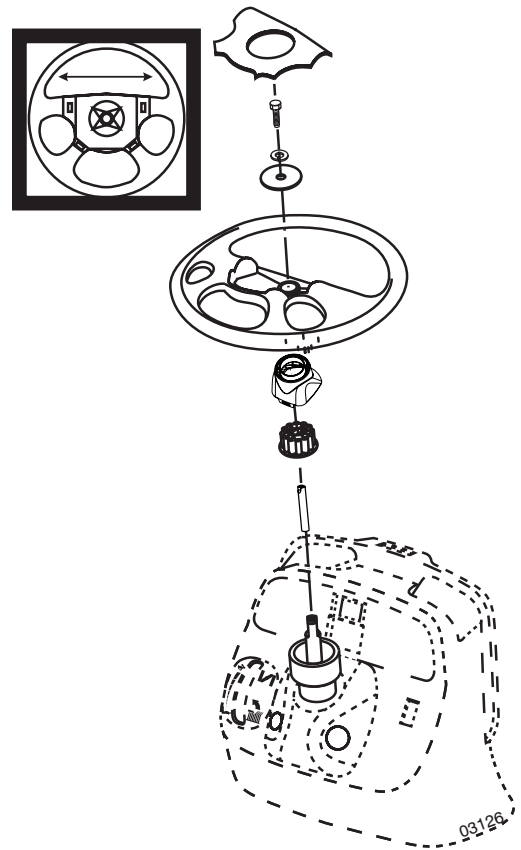

FIG. 1

CHECK BATTERY (See Fig. 2)

- Lift seat pan to raised position and open battery box door.
- If this battery is put into service after month and year indicated on label (label located between terminals) charge battery for minimum of one hour at 6-10 amps. (See "BATTERY" in Maintenance section of this manual for charging instructions).

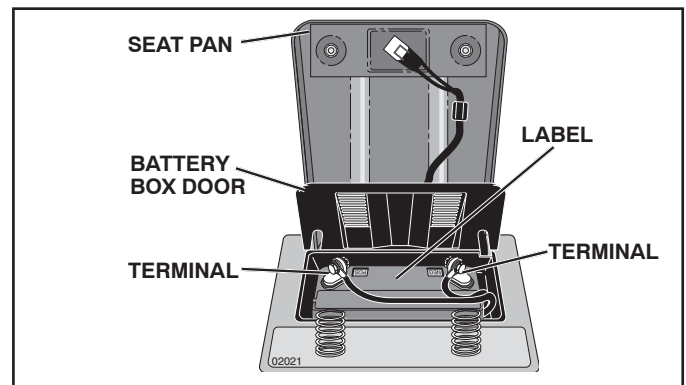

FIG. 2

ASSEMBLY

INSTALL SEAT (See Fig. 3)

Adjust seat before tightening adjustment knob.

- Remove adjustment knob and cup washer securing seat to cardboard packing and set aside.
- Remove seat from the cardboard packing and set seat aside. Remove the cardboard packing and discard.
- Place seat on seat pan so all three (3) bottom pads are positioned over large slotted holes in pan.
- Push down on seat to engage pads in slots and pull seat towards rear of tractor.
- Pivot seat and pan forward and assemble adjustment knob and cup washer loosely. Do not tighten.
- Lower seat into operating position and sit in seat.
- Slide seat until a comfortable position is reached which allows you to press clutch/brake pedal all the way down.
- Get off seat without moving its adjusted position.
- Raise seat and tighten adjustment knob securely.

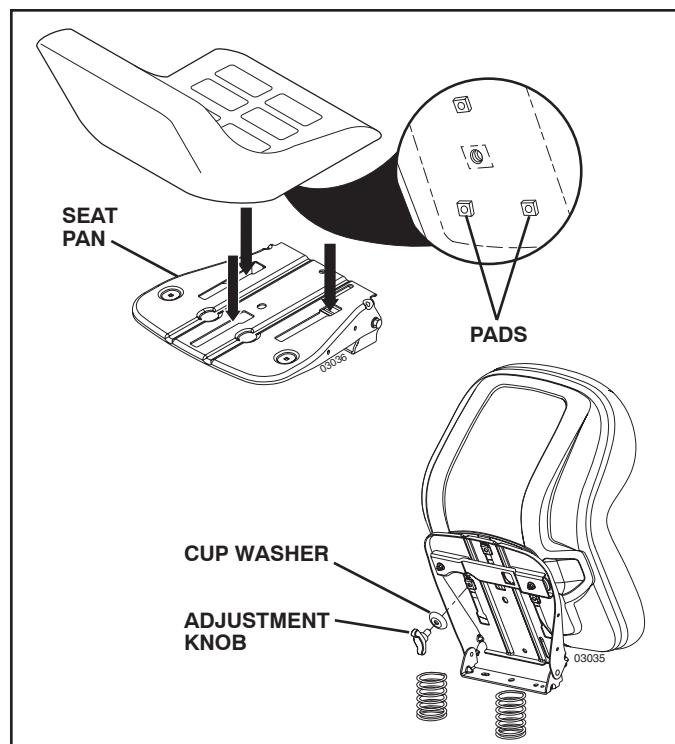

FIG. 3

NOTE: You may now roll or drive your tractor off the skid. Follow the appropriate instruction below to remove the tractor from the skid.

⚠ WARNING: Before starting, read, understand and follow all instructions in the Operation section of this manual. Be sure tractor is in a well-ventilated area. Be sure the area in front of tractor is clear of other people and objects.

TO ROLL TRACTOR OFF SKID (See Operation section for location and function of controls)

- Raise attachment lift lever to its highest position.
- Release parking brake by depressing clutch/brake pedal.
- Place freewheel control in "transmission disengaged position" (See "TO TRANSPORT" in the Operation section of this manual).
- Roll tractor forward off skid.
- Remove banding holding the deflector shield up against tractor.

TO DRIVE TRACTOR OFF SKID (See Operation section for location and function of controls)

⚠ WARNING: Before starting, read, understand and follow all instructions in the Operation section of this manual. Be sure tractor is in a well-ventilated area. Be sure the area in front of tractor is clear of other people and objects.

- Be sure all the above assembly steps have been completed.
- Check engine oil level and fill fuel tank with gasoline.
- Place freewheel control in "transmission engaged" position (see "TO TRANSPORT" in Operation section of this manual).
- Sit on seat in operating position, depress clutch/brake pedal and set the parking brake.
- Place motion control lever in neutral (N) position.
- Press lift lever plunger and raise attachment lift lever to its highest position.
- Remove key from bag and start the engine (see "TO START ENGINE" in the Operation section of this manual). After engine has started, move throttle control to idle (slow) position.
- Release parking brake.
- Slowly move the motion control lever forward and slowly drive tractor off skid.
- Apply brake to stop tractor, set parking brake and place motion control lever in neutral position.
- Turn ignition key to "STOP" position.

Continue with the instructions that follow.

ASSEMBLY

INSTALL MULCHER PLATE (See Fig. 4)

(If previously removed)

- Raise and hold deflector shield in upright position.
- Place slot in mulcher plate over tab on mower and position plate over mower opening as shown.
- Hook front latch into hole on front of mower deck.
- Hook rear latch into hole on back of mower deck.



CAUTION: Do not remove deflector shield from mower.

TO CONVERT TO BAGGING OR DISCHARGING

Simply remove mulcher plate and store in a safe place. Your mower is now ready for discharging or installation of optional grass catcher accessory.

NOTE: It is not necessary to change blades. The mulcher blades are designed for discharging and bagging also.

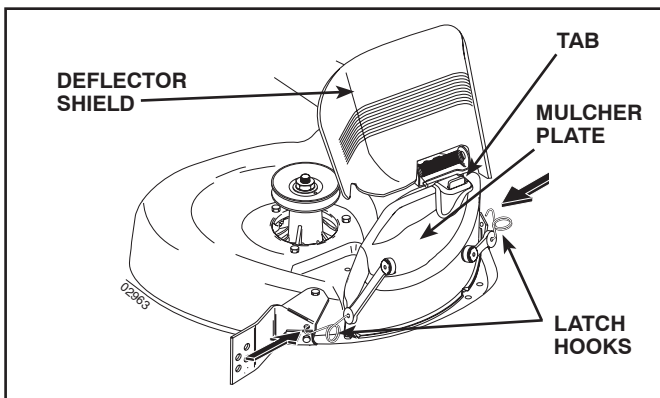

FIG. 4

CHECK TIRE PRESSURE

The tires on your tractor were overinflated at the factory for shipping purposes. Correct tire pressure is important for best cutting performance.

- Reduce tire pressure to PSI shown on tires.

CHECK DECK LEVELNESS

For best cutting results, mower housing should be properly leveled. See "TO LEVEL MOWER HOUSING" in the Service and Adjustments section of this manual.

CHECK FOR PROPER POSITION OF ALL BELTS

See the figures that are shown for replacing motion and mower blade drive belts in the Service and Adjustments section of this manual. Verify that the belts are routed correctly.

CHECK BRAKE SYSTEM

After you learn how to operate your tractor, check to see that the brake is operating properly. See "TO CHECK BRAKE" in the Service and Adjustments section of this manual.

✓ CHECKLIST

BEFORE YOU OPERATE YOUR NEW TRACTOR, WE WISH TO ASSURE THAT YOU RECEIVE THE BEST PERFORMANCE AND SATISFACTION FROM THIS QUALITY PRODUCT.

PLEASE REVIEW THE FOLLOWING CHECKLIST:

- ✓ All assembly instructions have been completed.
- ✓ No remaining loose parts in carton.
- ✓ Battery is properly prepared and charged.
- ✓ Seat is adjusted comfortably and tightened securely.
- ✓ All tires are properly inflated. (For shipping purposes, the tires were overinflated at the factory).
- ✓ Be sure mower deck is properly leveled side-to-side/front-to-rear for best cutting results. (Tires must be properly inflated for leveling).
- ✓ Check mower and drive belts. Be sure they are routed properly around pulleys and inside all belt keepers.
- ✓ Check wiring. See that all connections are still secure and wires are properly clamped.
- ✓ Before driving tractor, be sure freewheel control is in "transmission engaged" position (see "TO TRANSPORT" in the Operation section of this manual).

WHILE LEARNING HOW TO USE YOUR TRACTOR, PAY EXTRA ATTENTION TO THE FOLLOWING IMPORTANT ITEMS:

- ✓ Engine oil is at proper level.
- ✓ Fuel tank is filled with fresh, clean, regular unleaded gasoline.
- ✓ Become familiar with all controls, their location and function. Operate them before you start the engine.
- ✓ Be sure brake system is in safe operating condition.
- ✓ Be sure Operator Presence System and Reverse Operation System (ROS) are working properly (See the Operation and Maintenance sections in this manual).
- ✓ It is important to purge the transmission before operating your tractor for the first time. Follow proper starting and transmission purging instructions (See "TO START ENGINE" and "PURGE TRANSMISSION" in the Operation section of this manual).

OPERATION

These symbols may appear on your tractor or in literature supplied with the product. Learn and understand their meaning.

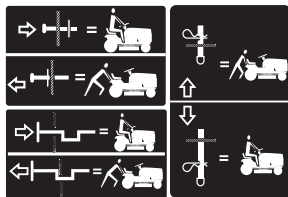

FREE WHEEL
(Automatic Models only)



Failure to follow instructions could result in serious injury or death. The safety alert symbol is used to identify safety information about hazards which can result in death, serious injury and/or property damage.



DANGER indicates a hazard which, if not avoided, will result in death or serious injury.



WARNING indicates a hazard which, if not avoided, could result in death or serious injury.



CAUTION indicates a hazard which, if not avoided, might result in minor or moderate injury.

CAUTION when used **without** the alert symbol, indicates a situation that **could result in damage to the tractor and/or engine.**



HOT SURFACES indicates a hazard which, if not avoided, could result in death, serious injury and/or property damage.



FIRE indicates a hazard which, if not avoided, could result in death, serious injury and/or property damage.

OPERATION

KNOW YOUR TRACTOR

READ THIS OWNER'S MANUAL AND SAFETY RULES BEFORE OPERATING YOUR TRACTOR

Compare the illustrations with your tractor to familiarize yourself with the locations of various controls and adjustments. Save this manual for future reference.

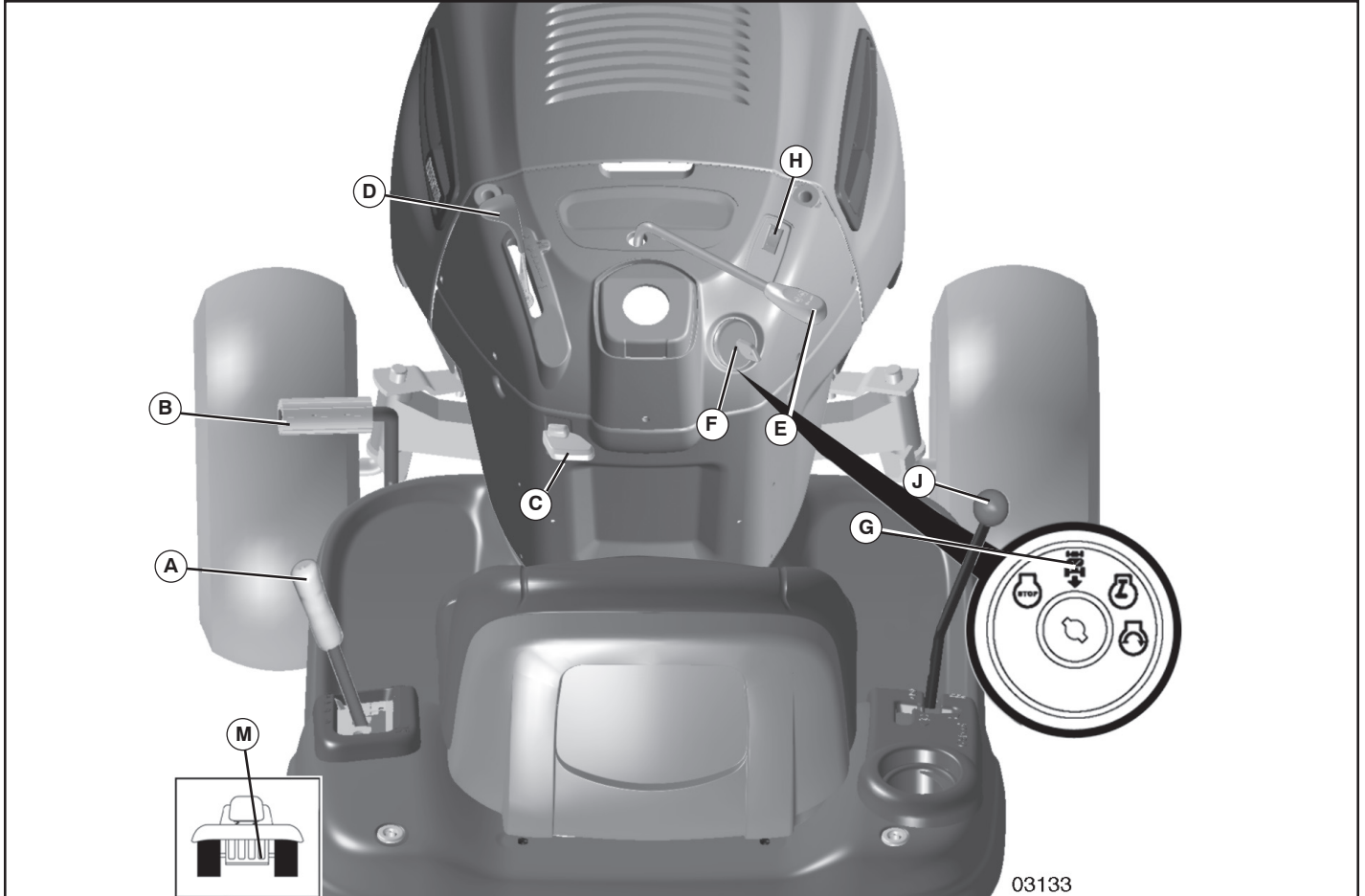

FIG. 5

Our tractors conform to the applicable safety standards of the American National Standards Institute.

(A) ATTACHMENT LIFT LEVER – Used to raise and lower the mower or other attachments mounted to your tractor.

(B) CLUTCH/BRAKE PEDAL – Used for braking the tractor and starting the engine.

(C) PARKING BRAKE – Locks clutch/brake pedal into the brake position.

(D) THROTTLE/CHOKE CONTROL - Used for starting and controlling engine speed.

(E) ATTACHMENT CLUTCH LEVER – Used to engage the mower blades, or other attachments mounted to your tractor.

(F) IGNITION SWITCH – Used for starting and stopping the engine.

(G) REVERSE OPERATION SYSTEM (ROS) "ON" POSITION – Allows operation of mower or other powered attachment while in reverse.

(H) LIGHT SWITCH – Turns the headlights on and off.

(J) MOTION CONTROL LEVER – Selects the speed and direction of tractor.

(M) FREEWHEEL CONTROL – Disengages transmission for pushing or slowly towing the tractor with the engine off.

OPERATION



The operation of any tractor can result in foreign objects thrown into the eyes, which can result in severe eye damage. Always wear safety glasses or eye shields while operating your tractor or performing any adjustments or repairs. We recommend standard safety glasses or a wide vision safety mask worn over spectacles.

HOW TO USE YOUR TRACTOR

TO SET PARKING BRAKE (See Fig. 6)

Your tractor is equipped with an operator presence sensing switch. When engine is running, any attempt by the operator to leave the seat without first setting the parking brake will shut off the engine.

1. Depress clutch/brake pedal (B) all the way down and hold.
2. Pull parking brake lever (C) up and hold, release pressure from clutch/brake pedal (B), then release parking brake lever. Pedal should remain in brake position. Make sure parking brake will hold tractor secure.

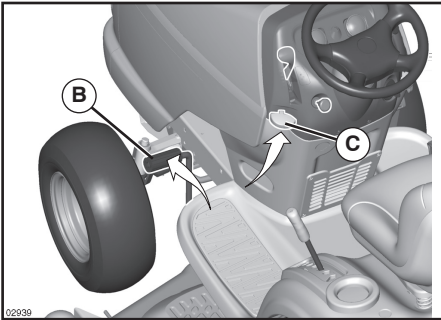

FIG. 6

STOPPING

MOWER BLADES -

- To stop mower blades, move attachment clutch lever to disengaged position (☒).

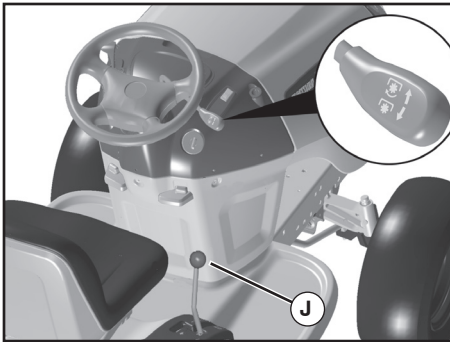

FIG. 7

(☒) Attachment Clutch Engage Position

(☒) Disengaged Position

GROUND DRIVE -

- To stop ground drive, depress clutch/brake pedal all the way down.
- Move motion control lever (J) to neutral position.

ENGINE -

- Move throttle control (D) between half and full speed (fast) position.

NOTE: Failure to move throttle control between half and full speed (fast) position, before stopping, may cause engine to “backfire”.

- Turn ignition key (F) to “STOP” position and remove key. Always remove key when leaving tractor to prevent unauthorized use.
- Never use choke to stop engine.

IMPORTANT: Leaving the ignition switch in any position other than “STOP” will cause the battery to discharge and go dead.

NOTE: Under certain conditions when tractor is standing idle with the engine running, hot engine exhaust gases may cause “browning” of grass. To eliminate this possibility, always stop engine when stopping tractor on grass areas.



CAUTION: Always stop tractor completely, as described above, before leaving the operator's position.

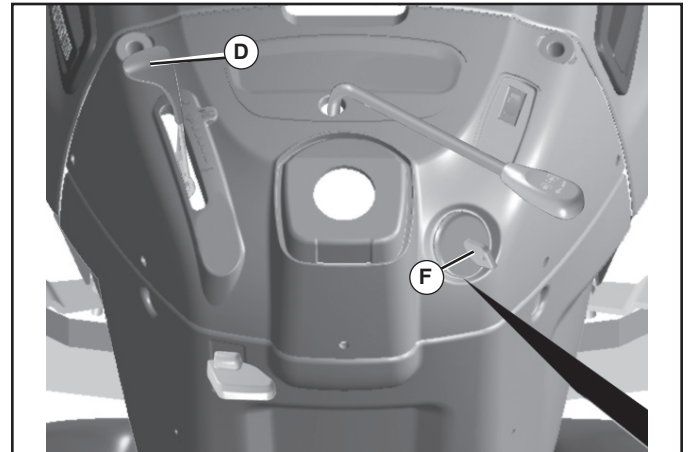

FIG. 8

TO USE THROTTLE CONTROL - D (See Fig. 8)

Always operate engine at full speed (fast).

- Operating engine at less than full speed (fast) reduces engines operating efficiency.
- Full speed (fast) offers the best bagging and mower performance.

OPERATION

TO MOVE FORWARD AND BACKWARD (See Fig. 9)

The direction and speed of movement is controlled by the motion control lever. (J)

- Start tractor with motion control lever in neutral (N) position.
- Release parking brake.
- Slowly move motion control lever to desired position.

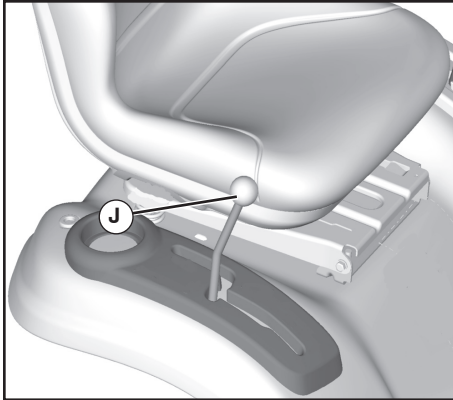

FIG. 9

TO ADJUST MOWER CUTTING HEIGHT (See Fig. 10)

The position of the attachment lift lever (A) determines the cutting height.

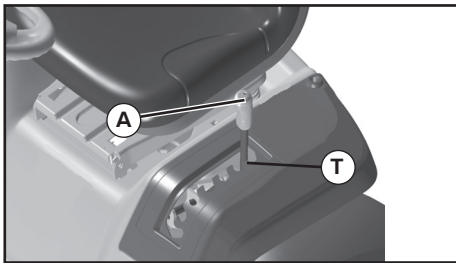

FIG. 10

- Put attachment lift lever in desired cutting height slot.
- Slide pointer tab (T) to desired cutting height as a reminder for next time you mow.

The cutting height range is approximately 1" to 4". The heights are measured from the ground to the blade tip with the engine not running. These heights are approximate and may vary depending upon soil conditions, height of grass and types of grass being mowed.

- The average lawn should be cut to approximately 2-1/2 inches during the cool season and to over 3 inches during hot months. For healthier and better looking lawns, mow often and after moderate growth.
- For best cutting performance, grass over 6 inches in height should be mowed twice. Make the first cut relatively high; the second to desired height.

TO ADJUST GAUGE WHEELS (See Fig. 11)

Gauge wheels are properly adjusted when they are slightly off the ground when mower is at the desired cutting height in operating position. Gauge wheels then keep the deck in proper position to help prevent scalping in most terrain conditions.

NOTE: Adjust gauge wheels with tractor on a flat level surface.

- Adjust mower to desired cutting height (See "TO ADJUST MOWER CUTTING HEIGHT" in this section of manual).
- With mower in desired height of cut position, gauge wheels should be assembled so they are slightly off the ground. Install gauge wheel in appropriate hole. Tighten securely.
- Repeat for all, installing gauge wheel in same adjustment hole.

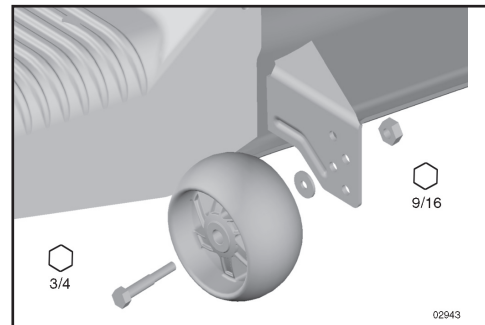

FIG. 11

TO OPERATE MOWER

Your tractor is equipped with an operator presence sensing switch. Any attempt by the operator to leave the seat with the engine running and the attachment clutch engaged will shut off the engine. You must remain fully and centrally positioned in the seat to prevent the engine from hesitating or cutting off when operating your equipment on rough, rolling terrain or hills.

- Select desired height of cut with attachment lift lever.
- Start mower blades by engaging attachment clutch control.

TO STOP MOWER BLADES -
disengage attachment clutch control.



CAUTION: Do not operate the mower without either the entire grass catcher, on mowers so equipped, or the deflector shield (S) in place.

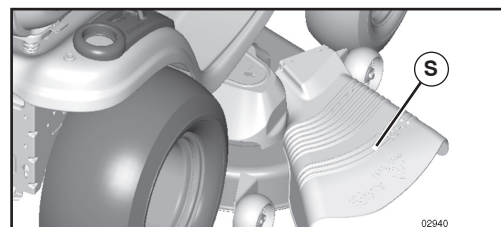

FIG. 12

OPERATION

REVERSE OPERATION SYSTEM (ROS)

Your tractor is equipped with a Reverse Operation System (ROS). Any attempt by the operator to travel in the reverse direction with the attachment clutch engaged will shut off the engine unless ignition key is placed in the ROS "ON" position.

⚠WARNING: Backing up with the attachment clutch engaged while mowing is strongly discouraged. Turning the ROS "ON", to allow reverse operation with the attachment clutch engaged, should only be done when the operator decides it is necessary to reposition the machine with the attachment engaged. **Do not mow in reverse unless absolutely necessary.**

USING THE REVERSE OPERATION SYSTEM -

Only use if you are certain no children or other bystanders will enter the mowing area.

- Move motion control lever to neutral (N) position.
- With engine running, turn ignition key counterclockwise to ROS "ON" position.
- Look down and behind before and while backing.
- Slowly move motion control lever to reverse (R) position to start movement.
- When use of the ROS is no longer needed, turn the ignition key clockwise to engine "ON" position.

ROS "ON" POSITION



ENGINE "ON" POSITION
(NORMAL OPERATING)



TO OPERATE ON HILLS



CAUTION: Do not drive up or down hills with slopes greater than 15° and do not drive across any slope.

- Choose the slowest speed before starting up or down hills.
- Avoid stopping or changing speed on hills.
- If stopping is absolutely necessary, push clutch/brake pedal quickly to brake position and engage parking brake.
- Move motion control lever to neutral (N) position.

IMPORTANT: THE MOTION CONTROL LEVER DOES NOT RETURN TO NEUTRAL (N) POSITION WHEN THE CLUTCH/BRAKE PEDAL IS DEPRESSED.

- To restart movement, slowly release parking brake and clutch/brake pedal.
- Slowly move motion control lever to slowest setting.
- Make all turns slowly.

TO TRANSPORT (See Figs. 5 and 13)

When pushing or towing your tractor, be sure to disengage transmission by placing freewheel control in freewheeling position. Free wheel control is located at the rear drawbar of tractor.

- Raise attachment lift to highest position with attachment lift control.
- Pull freewheel control out and down into the slot and release so it is held in the disengaged position.
- Do not push or tow tractor at more than two (2) MPH.
- To reengage transmission, reverse above procedure.

NOTE: To protect hood from damage when transporting your tractor on a truck or a trailer, be sure hood is closed and secured to tractor. Use an appropriate means of tying hood to tractor (rope, cord, etc.).

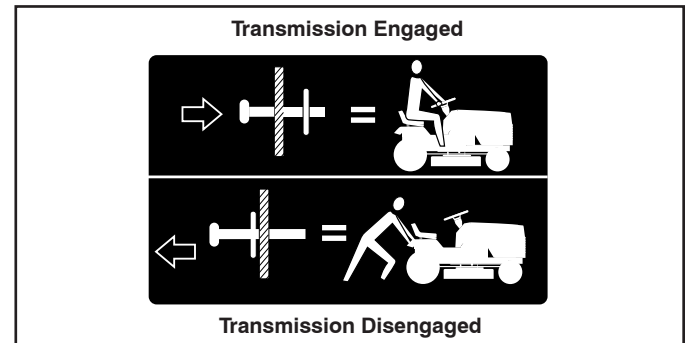

FIG. 13

TOWING CARTS AND OTHER ATTACHMENTS

Tow only the attachments that are recommended by and comply with specifications of the manufacturer of your tractor. Use common sense when towing. Too heavy of a load, while on a slope, is dangerous. Tires can lose traction with the ground and cause you to lose control of your tractor.

BEFORE STARTING THE ENGINE

CHECK ENGINE OIL LEVEL

The engine in your tractor has been shipped, from the factory, already filled with summer weight oil.

- Check engine oil with tractor on level ground.
- Remove oil fill cap/dipstick and wipe clean, reinsert the dipstick and screw cap tight, wait for a few seconds, remove and read oil level. If necessary, add oil until "FULL" mark on dipstick is reached. Do not overfill.
- For cold weather operation you should change oil for easier starting (See "OIL VISCOSITY CHART" in the Maintenance section of this manual).
- To change engine oil, see the Maintenance section in this manual.

OPERATION

ADD GASOLINE

- Fill fuel tank to bottom of filler neck. Do not overfill. Use fresh, clean, regular unleaded gasoline with a minimum of 87 octane. (Use of leaded gasoline will increase carbon and lead oxide deposits and reduce valve life). Do not mix oil with gasoline. Purchase fuel in quantities that can be used within 30 days to assure fuel freshness.



CAUTION: Wipe off any spilled oil or fuel. Do not store, spill or use gasoline near an open flame.

IMPORTANT: WHEN OPERATING IN TEMPERATURES BELOW 32°F (0°C), USE FRESH, CLEAN WINTER GRADE GASOLINE TO HELP INSURE GOOD COLD WEATHER STARTING.

CAUTION: Alcohol blended fuels (called gasohol or using ethanol or methanol) can attract moisture which leads to separation and formation of acids during storage. Acidic gas can damage the fuel system of an engine while in storage. To avoid engine problems, the fuel system should be emptied before storage of 30 days or longer. Drain the gas tank, start the engine and let it run until the fuel lines and carburetor are empty. Use fresh fuel next season. See Storage Instructions for additional information. Never use engine or carburetor cleaner products in the fuel tank or permanent damage may occur.

TO START ENGINE (See Fig. 5)

When starting the engine for the first time or if the engine has run out of fuel, it will take extra cranking time to move fuel from the tank to the engine.

- Be sure freewheel control is in the transmission engaged position.
- Sit on seat in operating position, depress clutch/brake pedal and set parking brake.
- Place motion control lever in neutral (N) position.
- Move attachment clutch to "DISENGAGED" position.
- Move throttle control to fast position
- Pull choke control out for a cold engine start attempt. For a warm engine start attempt the choke control may not be needed.

NOTE: Before starting, read the warm and cold starting procedures below.

- Insert key into ignition and turn key clockwise to "START" position and release key as soon as engine starts. Do not run starter continuously for more than fifteen seconds per minute. If the engine does not start after several attempts, push choke control in, wait a few minutes and try again. If engine still does not start, pull the choke control out and retry.

WARM WEATHER STARTING (50° F and above)

- When engine starts, slowly push choke control in until the engine begins to run smoothly. If the engine starts to run roughly, pull the choke control out slightly for a few seconds and then continue to push the control in slowly.

- The attachments and ground drive can now be used. If the engine does not accept the load, restart the engine and allow it to warm up for one minute using the choke as described above.

COLD WEATHER STARTING (50° F and below)

- When engine starts, slowly push choke control in until the engine begins to run smoothly. Continue to push the choke control in small steps allowing the engine to accept small changes in speed and load, until the choke control is fully in. If the engine starts to run roughly, pull the choke control out slightly for a few seconds and then continue to push the control in slowly. This may require an engine warm-up period from several seconds to several minutes, depending on the temperature.

AUTOMATIC TRANSMISSION WARM UP

- Before driving the unit in cold weather, the transmission should be warmed up as follows:
 - Be sure the tractor is on level ground.
 - Place the motion control lever in neutral. Release the parking brake and let the clutch/brake slowly return to operating position.
 - Allow one minute for transmission to warm up. This can be done during the engine warm up period.
- The attachments can be used during the engine warm-up period after the transmission has been warmed up and may require the choke control be pulled out slightly.

NOTE: If at a high altitude (above 3000 feet) or in cold temperatures (below 32 F) the carburetor fuel mixture may need to be adjusted for best engine performance. See "TO ADJUST CARBURETOR" in the Service and Adjustments section of this manual.

PURGE TRANSMISSION



CAUTION: Never engage or disengage freewheel lever while the engine is running.

To ensure proper operation and performance, it is recommended that the transmission be purged before operating tractor for the first time. This procedure will remove any trapped air inside the transmission which may have developed during shipping of your tractor.

IMPORTANT: SHOULD YOUR TRANSMISSION REQUIRE REMOVAL FOR SERVICE OR REPLACEMENT, IT SHOULD BE PURGED AFTER REINSTALLATION BEFORE OPERATING THE TRACTOR.

- Place tractor safely on a level surface - that is clear and open - with engine off and parking brake set.
- Disengage transmission by placing freewheel control in freewheeling position (See "TO TRANSPORT" in this section of manual).
- Sitting in the tractor seat, start engine. After the engine is running, move throttle control to slow position. With motion control lever in neutral (N) position, slowly disengage clutch/brake pedal.

OPERATION



CAUTION: At any time, during step 4, there may be movement of the drive wheels.

- Move motion control lever to full forward position and hold for five (5) seconds. Move lever to full reverse position and hold for five (5) seconds. Repeat this procedure three (3) times.
- Move motion control lever to neutral (N) position. Shut-off engine and set parking brake.
- Engage transmission by placing freewheel control in engaged position (See "TO TRANSPORT" in this section of manual).
- Sitting in the tractor seat, start engine. After the engine is running, move throttle control to half (1/2) speed. With motion control lever in neutral (N) position, slowly disengage clutch/brake pedal.
- Slowly move motion control lever forward, after the tractor moves approximately five (5) feet, slowly move motion control lever to reverse position. After the tractor moves approximately five (5) feet return the motion control lever to the neutral (N) position. Repeat this procedure with the motion control lever three (3) times.

Your transmission is now purged and now ready for normal operation.

MOWING TIPS

- Mower should be properly leveled for best mowing performance. See "TO LEVEL MOWER HOUSING" in the Service and Adjustments section of this manual.
- The left hand side of mower should be used for trimming.
- Drive so that clippings are discharged onto the area that has been cut. Have the cut area to the right of the machine. This will result in a more even distribution of clippings and more uniform cutting.
- When mowing large areas, start by turning to the right so that clippings will discharge away from shrubs, fences, driveways, etc. After one or two rounds, mow in the opposite direction making left hand turns until finished (See Fig. 13).

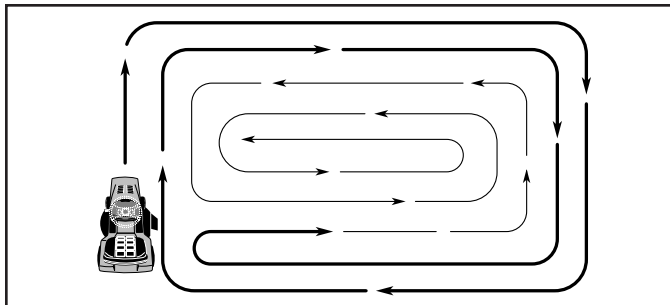

FIG. 14

- If grass is extremely tall, it should be mowed twice to reduce load and possible fire hazard from dried clippings. Make first cut relatively high; the second to the desired height.
- Do not mow grass when it is wet. Wet grass will plug mower and leave undesirable clumps. Allow grass to dry before mowing.
- **Always operate engine at full throttle when mowing** to assure better mowing performance and proper discharge of material. Regulate ground speed by selecting a low enough gear to give the mower cutting performance as well as the quality of cut desired.
- When operating attachments, select a ground speed that will suit the terrain and give best performance of the attachment being used.

MULCHING MOWING TIPS

IMPORTANT: FOR BEST PERFORMANCE, KEEP MOWER HOUSING FREE OF BUILT-UP GRASS AND TRASH. CLEAN AFTER EACH USE.

- The special mulching blade will recut the grass clippings many times and reduce them in size so that as they fall onto the lawn they will disperse into the grass and not be noticed. Also, the mulched grass will biodegrade quickly to provide nutrients for the lawn. Always mulch with your highest engine (blade) speed as this will provide the best recutting action of the blades.
- Avoid cutting your lawn when it is wet. Wet grass tends to form clumps and interferes with the mulching action. The best time to mow your lawn is the early afternoon. At this time the grass has dried, yet the newly cut area will not be exposed to direct sunlight.
- For best results, adjust the mower cutting height so that the mower cuts off only the top one-third of the grass blades (See Fig. 14). For extremely heavy mulching, reduce your width of cut on each pass and mow slowly.

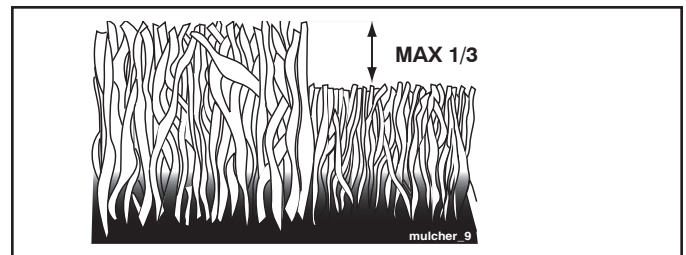

FIG. 15

- Certain types of grass and grass conditions may require that an area be mulched a second time to completely hide the clippings. When doing a second cut, mow across (perpendicular) to the first cut path.
- Change your cutting pattern from week to week. Mow north to south one week then change to east to west the next week. This will help prevent matting and graining of the lawn.

MAINTENANCE

MAINTENANCE SCHEDULE		BEFORE EACH USE	EVERY 8 HOURS	EVERY 25 HOURS	EVERY 50 HOURS	EVERY 100 HOURS	EVERY SEASON	BEFORE STORAGE
TRACTOR	Check Brake Operation	✓	✓					
	Check Tire Pressure	✓	✓					
	Check Operator Presence & ROS Systems	✓						
	Check for Loose Fasteners	✓				✓		✓
	Check/Replace Mower Blades			✓ ₃				
	Lubrication Chart			✓				✓
	Check Battery Level			✓ ₄				
	Clean Battery and Terminals			✓				✓
	Check Transaxle Cooling			✓				
	Check Mower Levelness				✓			
	Check V-Belts					✓		
	ENGINE	Check Engine Oil Level	✓	✓				
Change Engine Oil (with oil filter)					✓ _{1,2}			✓
Change Engine Oil (without oil filter)				✓ _{1,2}				✓
Clean Air Filter				✓ ₂				
Clean Air Screen				✓ ₂				
Inspect Muffler/Spark Arrester					✓			
Replace Oil Filter (If equipped)						✓ _{1,2}		
Clean Engine Cooling Fins						✓ ₂		
Replace Spark Plug						✓	✓	
Replace Air Filter Paper Cartridge						✓ ₂		
Replace Fuel Filter							✓	

- 1 - Change more often when operating under a heavy load or in high ambient temperatures.
 2 - Service more often when operating in dirty or dusty conditions.

- 3 - Replace blades more often when mowing in sandy soil.
 4 - Not required if equipped with maintenance-free battery.

maint_sch-tractor_FOS.e

GENERAL RECOMMENDATIONS

The warranty on this tractor does not cover items that have been subjected to operator abuse or negligence. To receive full value from the warranty, operator must maintain tractor as instructed in this manual.

Some adjustments will need to be made periodically to properly maintain your tractor.

At least once a season, check to see if you should make any of the adjustments described in the Service and Adjustments section of this manual.

- At least once a year you should replace the spark plug, clean or replace air filter, and check blades and belts for wear. A new spark plug and clean air filter assure proper air-fuel mixture and help your engine run better and last longer.

BEFORE EACH USE

- Check engine oil level.
- Check brake operation.
- Check tire pressure.
- Check operator presence and ROS systems for proper operation.
- Check for loose fasteners.

LUBRICATION CHART

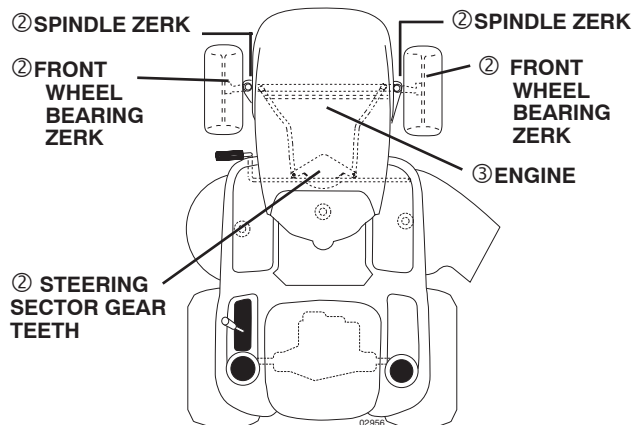

- ② General Purpose Grease
 ③ Refer to Maintenance "ENGINE" Section

IMPORTANT: DO NOT OIL OR GREASE THE PIVOT POINTS WHICH HAVE SPECIAL NYLON BEARINGS. VISCOUS LUBRICANTS WILL ATTRACT DUST AND DIRT THAT WILL SHORTEN THE LIFE OF THE SELF-LUBRICATING BEARINGS. IF YOU FEEL THEY MUST BE LUBRICATED, USE ONLY A DRY, POWDERED GRAPHITE TYPE LUBRICANT SPARINGLY.

MAINTENANCE

TRACTOR

Always observe safety rules when performing any maintenance.

BRAKE OPERATION

If tractor requires more than five (5) feet to stop at highest speed in highest gear on a level, dry concrete or paved surface, then brake must be serviced. (See "TO CHECK BRAKE" in the Service and Adjustments section of this manual).

TIRES

- Maintain proper air pressure in all tires (See PSI on tires).
- Keep tires free of gasoline, oil, or insect control chemicals which can harm rubber.
- Avoid stumps, stones, deep ruts, sharp objects and other hazards that may cause tire damage.

NOTE: To seal tire punctures and prevent flat tires due to slow leaks, tire sealant may be purchased from your local parts dealer. Tire sealant also prevents tire dry rot and corrosion.

OPERATOR PRESENCE SYSTEM AND REVERSE OPERATION SYSTEM (ROS)

Be sure operator presence and reverse operation systems are working properly. If your tractor does not function as described, repair the problem immediately.

- The engine should not start unless the brake pedal is fully depressed, and the attachment clutch control is in the disengaged position.

CHECK OPERATOR PRESENCE SYSTEM

- When the engine is running, any attempt by the operator to leave the seat without first setting the parking brake should shut off the engine.
- When the engine is running and the attachment clutch is engaged, any attempt by the operator to leave the seat should shut off the engine.
- The attachment clutch should never operate unless the operator is in the seat.

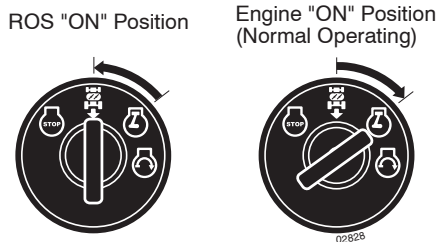

CHECK REVERSE OPERATION (ROS) SYSTEM

- When the engine is running with the ignition switch in the engine "ON" position and the attachment clutch engaged, any attempt by the operator to shift into reverse should shut off the engine.
- When the engine is running with the ignition switch in the ROS "ON" position and the attachment clutch engaged, any attempt by the operator to shift into reverse should NOT shut off the engine.

BLADE CARE

For best results mower blades must be sharp. Replace worn, bent or damaged blades.



CAUTION: Use only a replacement blade approved by the manufacturer of your tractor. Using a blade not approved by the manufacturer of your tractor is hazardous, could damage your tractor and void your warranty.

BLADE REMOVAL (See Fig. 16)

- Raise mower to highest position to allow access to blades.

NOTE: Protect your hands with gloves and/or wrap blade with heavy cloth.

- Remove blade bolt by turning counterclockwise.
- Install new blade with stamped "GRASS SIDE" facing the ground.

IMPORTANT: To ensure proper assembly, center hole in blade must align with star on mandrel assembly.

- Install and tighten blade bolt securely (45-55 Ft. Lbs. torque).

IMPORTANT: Special blade bolt is heat treated.

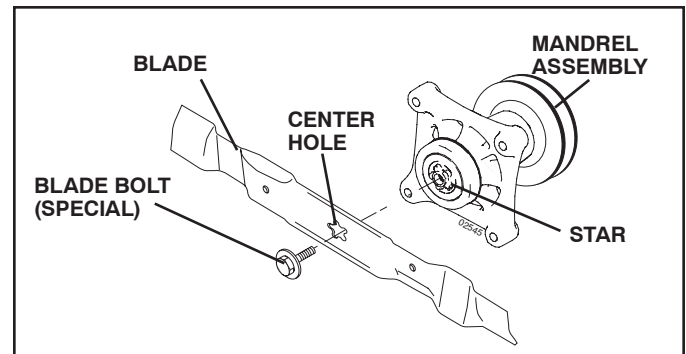

FIG. 16

BATTERY

Your tractor has a battery charging system which is sufficient for normal use. However, periodic charging of the battery with an automotive charger will extend its life.

- Keep battery and terminals clean.
- Keep battery bolts tight.
- Keep small vent holes open.
- Recharge at 6-10 amperes for 1 hour.

NOTE: The original equipment battery on your tractor is maintenance free. Do not attempt to open or remove caps or covers. Adding or checking level of electrolyte is not necessary.

TO CLEAN BATTERY AND TERMINALS

Corrosion and dirt on the battery and terminals can cause the battery to "leak" power.

- Remove terminal guard.
- Disconnect BLACK battery cable first then RED battery cable and remove battery from tractor.

MAINTENANCE

- Rinse the battery with plain water and dry.
- Clean terminals and battery cable ends with wire brush until bright.
- Coat terminals with grease or petroleum jelly.
- Reinstall battery (See "CONNECT BATTERY" in the Assembly section of this manual).

V-BELTS

Check V-belts for deterioration and wear after 100 hours of operation and replace if necessary. The belts are not adjustable. Replace belts if they begin to slip from wear.

TRANSAXLE COOLING

The transmission fan and cooling fins should be kept clean to assure proper cooling.

Do not attempt to clean fan or transmission while engine is running or while the transmission is hot. To prevent possible damage to seals, do not use high pressure water or steam to clean transaxle.

- Inspect cooling fan to be sure fan blades are intact and clean.
- Inspect cooling fins for dirt, grass clippings and other materials. To prevent damage to seals, do not use compressed air or high pressure sprayer to clean cooling fins.

TRANSAXLE PUMP FLUID

The transaxle was sealed at the factory and fluid maintenance is not required for the life of the transaxle. Should the transaxle ever leak or require servicing, contact your nearest authorized service center/department.

ENGINE

LUBRICATION

Only use high quality detergent oil rated with API service classification SG-SL. Select the oil's SAE viscosity grade according to your expected operating temperature. When operating in temperatures below 0° F (-18° C) synthetic oil must be used.

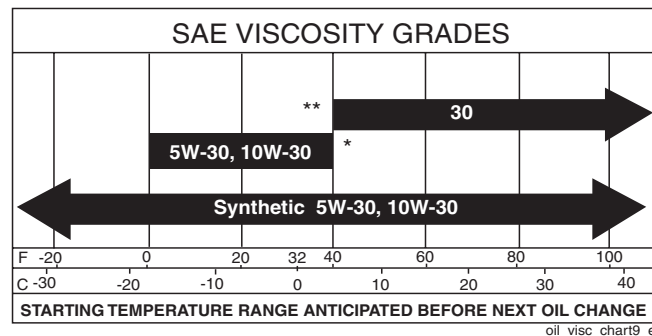

FIG. 17

*** CAUTION:** Air cooled engines run hotter than automotive engines. The use of non-synthetic multi-viscosity oils (5W30, 10W30 etc.) in temperatures above 40° F (4° C) will result in higher than normal oil consumption. When using a multi-viscosity oil, check oil level more frequently.

**** CAUTION:** SAE 30 oil, if used below 40° F (4° C), will result in hard starting and possible engine bore damage due to inadequate lubrication.



NOTE: Synthetic oil meeting ILSAC GF-2, API certification mark and API service symbol (shown at left) with "SJ/CF ENERGY CONSERVING" or higher, is an acceptable oil at all temperatures. **Use of synthetic oil does not alter required oil change intervals.**

Change the oil after every 50 hours of operation or at least once a year if the tractor is not used for 50 hours in one year.

Check the crankcase oil level before starting the engine and after each eight (8) hours of operation. Tighten oil fill cap/dipstick securely each time you check the oil level.

TO CHANGE ENGINE OIL (See Figs. 17 and 18)

Determine temperature range expected before oil change. All oil must meet API service classification SG-SL.

- Be sure tractor is on level surface.
- Oil will drain more freely when warm.
- Catch oil in a suitable container.
- Remove oil fill cap/dipstick. Be careful not to allow dirt to enter the engine when changing oil.
- Remove yellow cap from end of drain valve and install the drain tube onto the fitting.

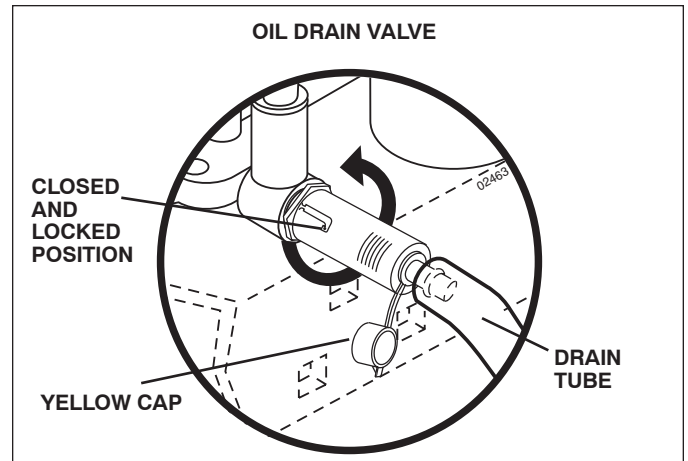

FIG. 18

- Unlock drain valve by pushing inward and turning counterclockwise.
- To open, pull out on the drain valve.
- After oil has drained completely, close and lock the drain valve by pushing inward and turning clockwise until the pin is in the locked position as shown.
- Remove the drain tube and replace the cap onto to the bottom fitting of the drain valve.
- Refill engine with oil through oil fill dipstick tube. Pour slowly. Do not overfill. For approximate capacity see "PRODUCT SPECIFICATIONS" section of this manual.
- Use gauge on oil fill cap/dipstick for checking level. Be sure dipstick cap is tightened securely for accurate reading. Keep oil at "FULL" line on dipstick. Tighten cap onto the tube securely when finished.

MAINTENANCE

CLEAN AIR SCREEN

Air screen must be kept free of dirt and chaff to prevent engine damage from overheating. Clean with a wire brush or compressed air to remove dirt and stubborn dried gum fibers.

AIR FILTER (See Fig. 19)

Your engine will not run properly using a dirty air filter. Replace pre-cleaner after every 25 hours of operation or every season. Service paper cartridge every 100 hours of operation or every season, whichever occurs first.

Service air cleaner more often under dusty conditions.

- Pull up on air filter cover handle and rotate towards engine.
- Remove cover.
- Carefully remove air filter cartridge and pre-cleaner from base.
- Clean base carefully to prevent debris from falling into carburetor.

NOTE: If very dirty or damaged, replace cartridge.

- Place new pre-cleaner and cartridge firmly in base.
- Align tabs on cover with slots in blower housing and replace cover.
- Hook handle on cover and push down on handle to close.

IMPORTANT: Petroleum solvents, such as kerosene, are not to be used to clean the cartridge. They may cause deterioration of the cartridge. Do not oil cartridge. Do not use pressurized air to clean cartridge.

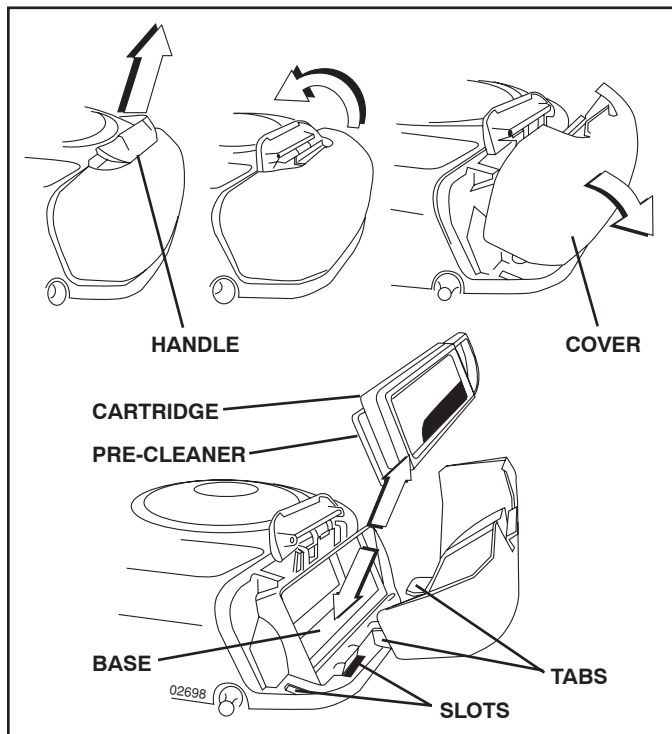

FIG. 19

ENGINE OIL FILTER

Replace the engine oil filter every season or every other oil change if the tractor is used more than 100 hours in one year.

CLEAN AIR INTAKE/COOLING AREAS

To insure proper cooling, make sure the grass screen, cooling fins, and other external surfaces of the engine are kept clean at all times.

Every 100 hours of operation (more often under extremely dusty, dirty conditions), remove the blower housing and other cooling shrouds. Clean the cooling fins and external surfaces as necessary. Make sure the cooling shrouds are reinstalled.

NOTE: Operating the engine with a blocked grass screen, dirty or plugged cooling fins, and/or cooling shrouds removed will cause engine damage due to overheating.

MUFFLER

Inspect and replace corroded muffler and spark arrester (if equipped) as it could create a fire hazard and/or damage.

SPARK PLUGS

Replace spark plugs at the beginning of each mowing season or after every 100 hours of operation, whichever occurs first. Spark plug type and gap setting are shown in "PRODUCT SPECIFICATIONS" section of this manual.

IN-LINE FUEL FILTER (See Fig. 20)

The fuel filter should be replaced once each season. If fuel filter becomes clogged, obstructing fuel flow to carburetor, replacement is required.

- With engine cool, remove filter and plug fuel line sections.
- Place new fuel filter in position in fuel line with arrow pointing towards carburetor.
- Be sure there are no fuel line leaks and clamps are properly positioned.
- Immediately wipe up any spilled gasoline.

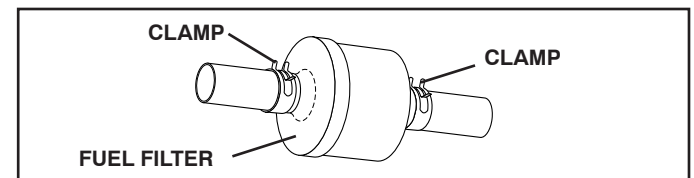

FIG. 20

CLEANING

- Clean engine, battery, seat, finish, etc. of all foreign matter.
- Keep finished surfaces and wheels free of all gasoline, oil, etc.
- Protect painted surfaces with automotive type wax.

We do not recommend using a garden hose or pressure washer to clean your tractor unless the engine and transmission are covered to keep water out. Water in engine or transmission will shorten the useful life of your tractor. Use compressed air or a leaf blower to remove grass, leaves and trash from tractor and mower.

SERVICE AND ADJUSTMENTS



WARNING: TO AVOID SERIOUS INJURY, BEFORE PERFORMING ANY SERVICE OR ADJUSTMENTS:

- Depress clutch/brake pedal fully and set parking brake.
- Place motion control lever in neutral (N) position.
- Place attachment clutch in “DISENGAGED” position.
- Turn ignition key to “STOP” and remove key.
- Make sure the blades and all moving parts have completely stopped.
- Disconnect spark plug wire from spark plug and place wire where it cannot come in contact with plug.

TO REMOVE MOWER (See Fig. 21)

- Place attachment clutch in “DISENGAGED” position.
- Lower attachment lift lever to its lowest position.
- Roll belt off engine pulley (M) and belt keepers (G).
- Remove retainer spring (K), slide collar (L) off and push housing guide (P) out of bracket.
- Remove clutch cable spring (Q) from idler arm (R).
- Disconnect front link (E) from mower - remove retainer spring and washer.
- Go to either side of mower and disconnect mower suspension arm (A) from chassis pin (B) and rear lift link (C) from rear mower bracket (D) - remove retainer springs and washers.



CAUTION: AFTER REAR LIFT LINKS ARE DISCONNECTED, THE ATTACHMENT LIFT LEVER WILL BE SPRING LOADED. HAVE A TIGHT GRIP ON LIFT LEVER WHEN CHANGING POSITION OF THE LEVER.

- Slide mower out from under right side of tractor.

IMPORTANT: IF AN ATTACHMENT OTHER THAN THE

MOWER IS TO BE MOUNTED ON THE TRACTOR, REMOVE THE FRONT LINK (E) AND REAR LIFT LINKS (C) FROM TRACTOR AND HOOK THE CLUTCH SPRING (Q) INTO THE CABLE GUIDE ON FRONT EDGE OF LOWER DASH.

TO INSTALL MOWER (See Fig. 21–25)

Be sure tractor is on level surface and engage parking brake.

- Lower attachment lift lever to it's lowest position.



CAUTION: LIFT LEVER IS SPRING LOADED. HAVE A TIGHT GRIP ON LIFT LEVER, LOWER IT SLOWLY AND ENGAGE IN LOWEST POSITION.

NOTE: Be sure mower side suspension arms (A) are pointing forward before sliding mower under tractor.

- Slide mower under tractor until it is centered under tractor.
- ATTACH MOWER SIDE SUSPENSION ARMS (A) TO CHASSIS - Position hole in arm over pin (B) on outside of tractor chassis and secure with retainer spring.
- Repeat on opposite side of tractor.
- ATTACH REAR LIFT LINKS (C) - Lift rear corner of mower and position slot in link assembly over pin (D)

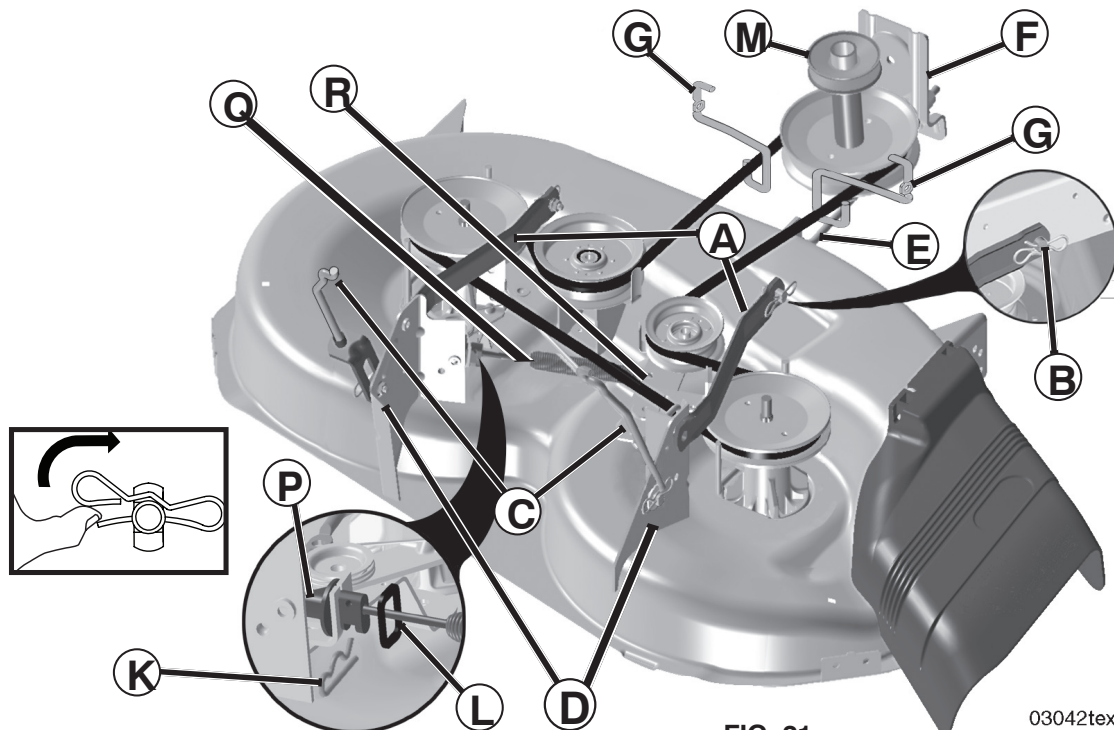

FIG. 21

03042tex

SERVICE AND ADJUSTMENTS

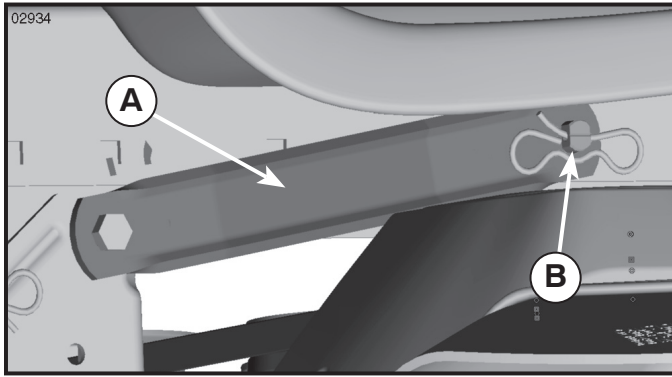

FIG. 22

on rear mower bracket and secure with washer and retainer spring.

- ATTACH FRONT LINK (E) - Work from left side of trac-

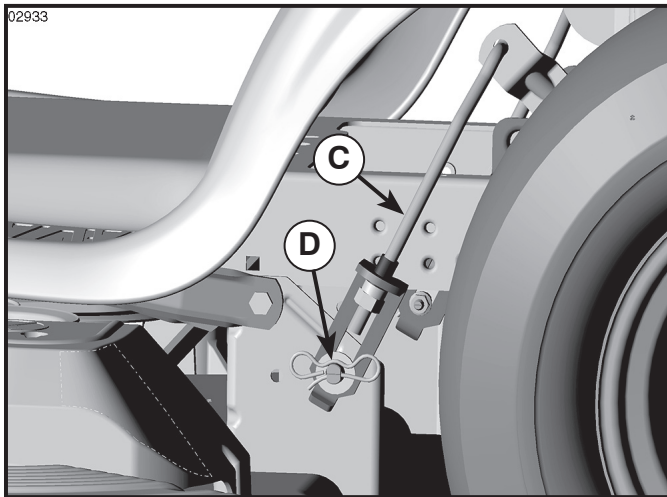

FIG. 23

tor. Insert rod end of link assembly through front hole in tractor front suspension bracket (F).

- Insert end of link (E) into hole in front mower bracket and secure with washer and retainer spring (J).
- Hook end of clutch cable spring (Q) into hole in idler

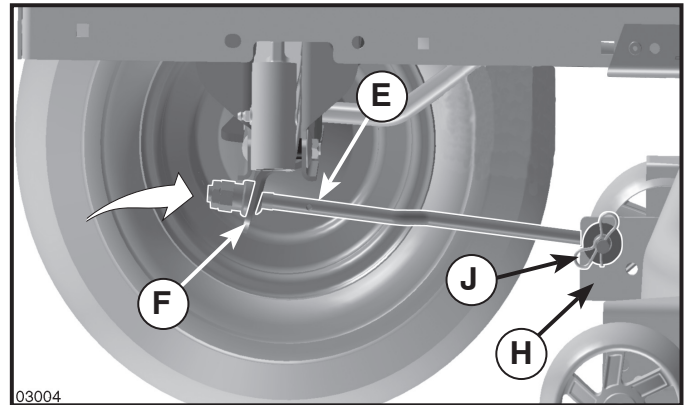

FIG. 24

arm (R).

- Push clutch cable housing guide (P) into bracket, slide collar (L) onto guide and secure with retainer spring (K).
- Install belt on engine pulley (M), in belt keepers (G).

IMPORTANT: CHECK BELT FOR PROPER ROUTING IN ALL MOWER PULLEY GROOVES.

- Raise attachment lift lever to highest position.
- If necessary, adjust gauge wheels before operating mower as shown in the Operation section of this manual.

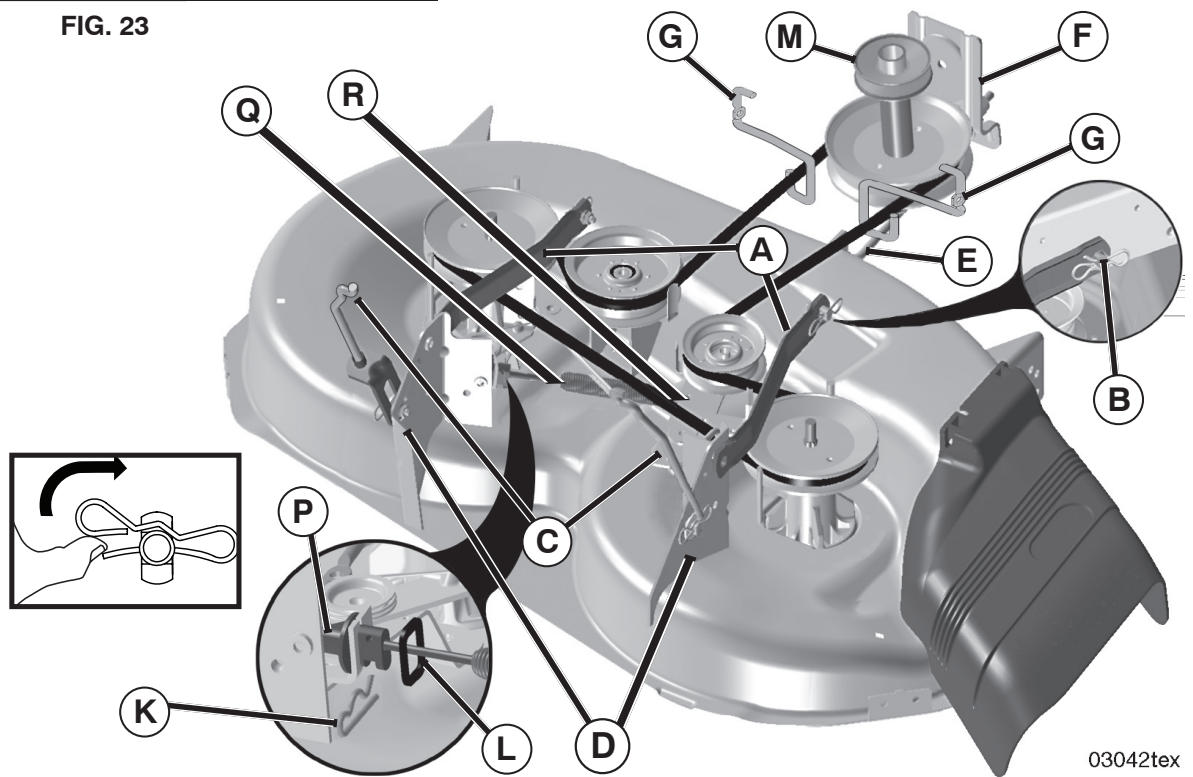

FIG. 25

03042tex

SERVICE AND ADJUSTMENTS

TO LEVEL MOWER

Make sure tires are properly inflated to the PSI shown on tires. If tires are over or under inflated, it may affect the appearance of your lawn and lead you to think the mower is not adjusted properly.

VISUAL SIDE-TO-SIDE ADJUSTMENT (See Fig. 26)

- With all tires properly inflated and if your lawn appears unevenly cut, determine which side of mower is cutting lower.
- With a 3/4" or adjustable wrench, turn lift link adjustment nut (A) to the left to lower LH side of mower, or, to the right to raise LH side of mower.

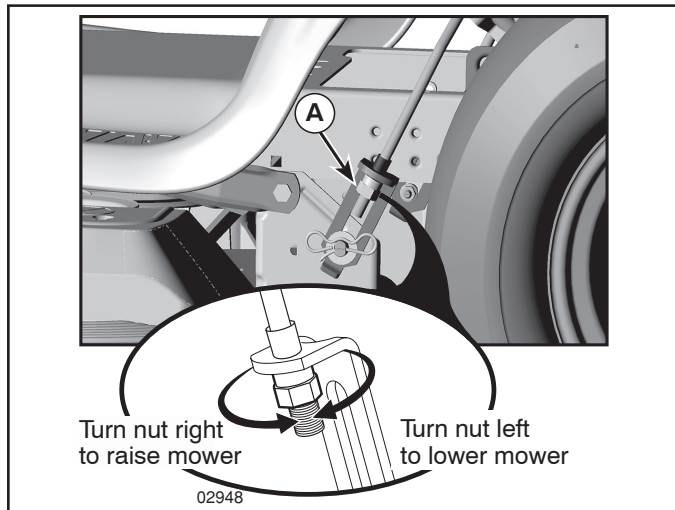

FIG. 26

NOTE: Each full turn of adjustment nut will change mower height about 3/16".

- Test your adjustment by mowing some uncut grass and visually checking the appearance. Readjust, if necessary, until you are satisfied with the results.

PRECISION SIDE-TO-SIDE ADJUSTMENT (See Fig. 27)

- With all tires properly inflated, park tractor on level ground or driveway.



CAUTION: Blades are sharp. Protect your hands with gloves and/or wrap blade with heavy cloth.

- Raise mower to its highest position.
- At both sides of mower, position blade at side and measure the distance (A) from bottom edge of blade to the ground. The distance should be the same on both sides.

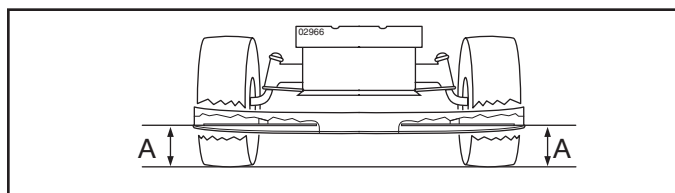

FIG. 27

- If adjustment is necessary, see step in Visual Adjustment instructions above.
- Recheck measurements, adjust if necessary until both sides are equal.

FRONT-TO-BACK ADJUSTMENT (See Figs. 28 and 29)

IMPORTANT: Deck must be level side-to-side.

To obtain the best cutting results, the mower blades should be adjusted so the front tip is 1/8" to 1/2" lower than the rear tip when the mower is in its highest position.



CAUTION: Blades are sharp. Protect your hands with gloves and/or wrap blade with heavy cloth.

- Raise mower to highest position.
- Position any blade so the tip is pointing straight forward. Measure distance (B) to the ground at front and rear tip of the blade.
- If front tip of blade is not 1/8" to 1/2" lower than the rear

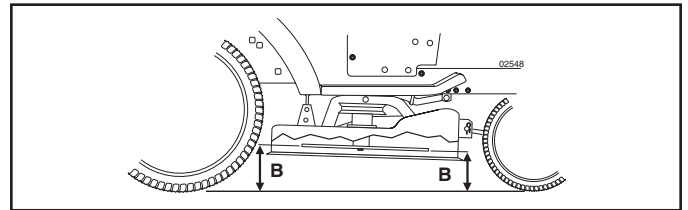

FIG. 28

tip, go to the front of tractor.

- With an 11/16" or adjustable wrench, loosen jam nut A several turns to clear adjustment nut B.
- With a 3/4" or adjustable wrench, turn front link adjustment nut (B) clockwise (tighten) to raise the front of mower, or, counterclockwise (loosen) to lower the front mower.

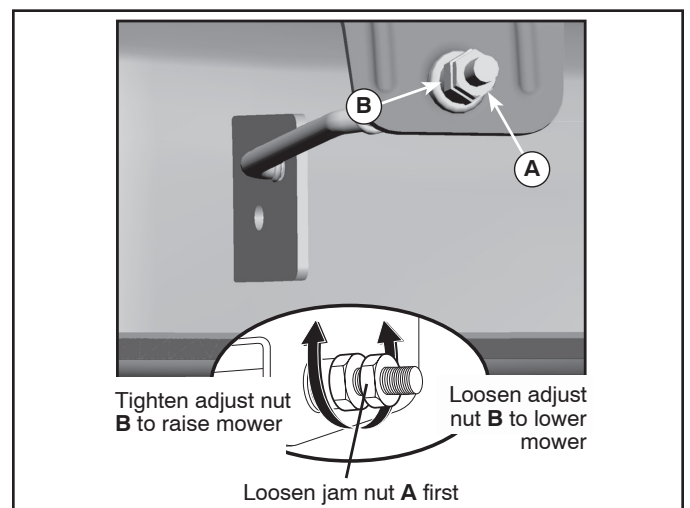

FIG. 29

NOTE: Each full turn of the adjustment nut will change mower height about 1/8".

- Recheck measurements, adjust if necessary until front tip of blade is 1/8" to 1/2" lower than the rear tip.
- Hold adjustment nut in position with wrench and tighten jam nut securely against adjustment nut.

SERVICE AND ADJUSTMENTS

TO REPLACE MOWER DRIVE BELT

(See Fig. 30)

MOWER DRIVE BELT REMOVAL

- Park tractor on a level surface. Engage parking brake.
- Lower attachment lift lever to its lowest position.
- Remove any dirt or grass clippings which may have accumulated around mandrels and entire upper deck surface.
- Remove belt from electric clutch pulley (M), both mandrel pulleys (R) and all idler pulleys (S).

MOWER DRIVE BELT INSTALLATION

- Install belt around all mandrel pulleys (R) and around idler pulleys (S) as shown.
- Install belt onto electric clutch pulley (M).

IMPORTANT: Check belt for proper routing in all mower pulley grooves.

- Raise attachment lift lever to highest position.

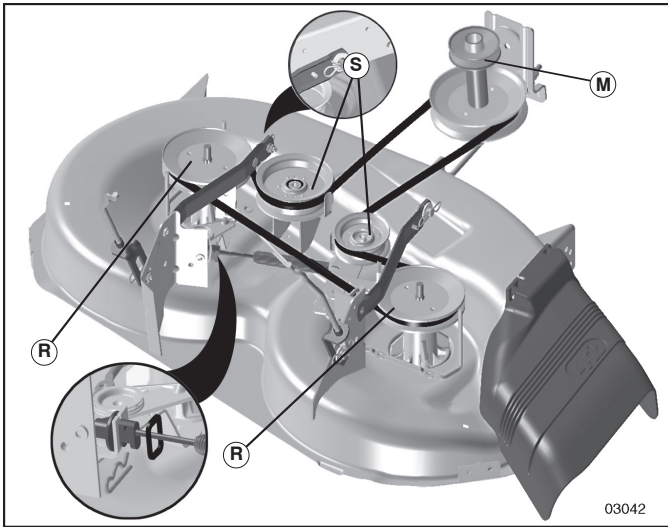

FIG. 30

TO CHECK BRAKE

If tractor requires more than five (5) feet to stop at highest speed in highest gear on a level, dry concrete or paved surface, then brake must be serviced.

You may also check brake by:

1. Park tractor on a level, dry concrete or paved surface, depress clutch/brake pedal all the way down and engage parking brake.
2. Disengage transmission by placing freewheel control in "transmission disengaged" position. Pull freewheel control out and into the slot and release so it is held in the disengaged position.

The rear wheels must lock and skid when you try to manually push the tractor forward. If the rear wheels rotate, then the brake needs to be serviced. Contact a Sears or other qualified service center.

TO REPLACE MOTION DRIVE BELT

(See Fig. 31)

Park the tractor on level surface. Engage parking brake. For assistance, there is a belt installation guide decal on bottom side of left footrest.

BELT REMOVAL -

- Remove mower (See "TO REMOVE MOWER" in this section of manual).

NOTE: Observe entire motion drive belt and position of all belt guides and keepers.

- Remove belt from stationary idler (A) and clutching idler (B).
- Remove belt from centerspan idler (C).
- Pull belt slack toward rear of tractor. Remove belt upwards from transaxle input pulley (D).
- Remove belt downward from engine pulley (E).
- Slide belt toward rear of tractor, off the steering plate (F) and remove from tractor.

BELT INSTALLATION -

- Install new belt from tractor rear to front, over the steering plate (F) and above clutch brake pedal shaft (G).
- Pull belt toward front of tractor and roll belt onto engine pulley (E).
- Pull belt toward rear of tractor. Carefully work belt down around transaxle input pulley (D). Be sure belt is inside the belt keeper.

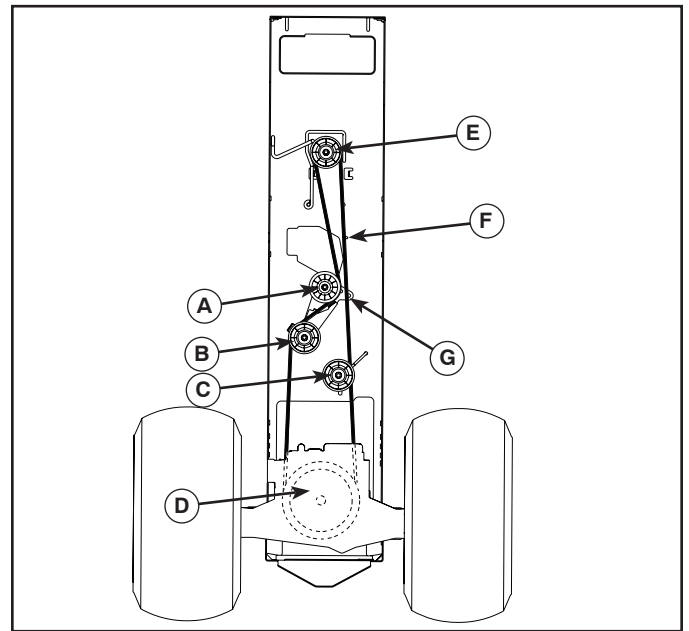

FIG. 31

- Install belt on centerspan idler (C).
- Install belt through stationary idler (A) and clutching idler (B).
- Make sure belt is in all pulley grooves and inside all belt guides and keepers.
- Install mower (See "TO INSTALL MOWER" in this section of manual).

SERVICE AND ADJUSTMENTS

FRONT WHEEL TOE-IN/CAMBER

Your new tractor front wheel toe-in and camber is set at the factory and is normal. The front wheel toe-in and camber are not adjustable. If damage has occurred to affect the factory set front wheel toe-in or camber, contact a qualified service center.

TO REMOVE WHEEL FOR REPAIRS (See Fig. 32)

- Block up axle securely.
- Remove axle cover, retaining ring and washers to allow wheel removal (rear wheel contains a square key - Do not lose).
- Repair tire and reassemble.
- On rear wheels only: align grooves in rear wheel hub and axle. Insert square key.
- Replace washers and snap retaining ring securely in axle groove.
- Replace axle cover.

NOTE: To seal tire punctures and prevent flat tires due to slow leaks, tire sealant may be purchased from your local parts dealer. Tire sealant also prevents tire dry rot and corrosion.

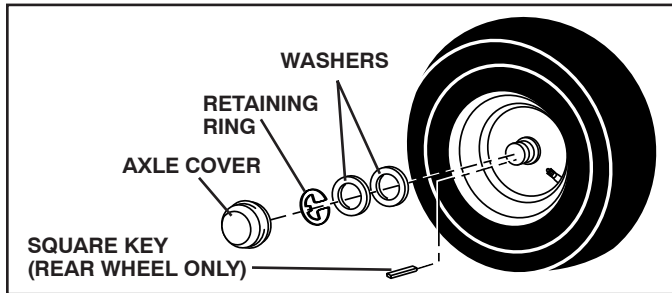

FIG. 32

TO START ENGINE WITH A WEAK BATTERY (See Fig. 33)



WARNING: Lead-acid batteries generate explosive gases. Keep sparks, flame and smoking materials away from batteries. Always wear eye protection when around batteries.

If your battery is too weak to start the engine, it should be recharged. (See "BATTERY" in the MAINTENANCE section of this manual).

If "jumper cables" are used for emergency starting, follow this procedure:

IMPORTANT: YOUR TRACTOR IS EQUIPPED WITH A 12 VOLT SYSTEM. THE OTHER VEHICLE MUST ALSO BE A 12 VOLT SYSTEM. DO NOT USE YOUR TRACTOR BATTERY TO START OTHER VEHICLES.

TO ATTACH JUMPER CABLES -

- Connect one end of the RED cable to the POSITIVE (+) terminal of each battery (A-B), taking care not to short against tractor chassis.
- Connect one end of the BLACK cable to the NEGATIVE (-) terminal (C) of fully charged battery.
- Connect the other end of the BLACK cable (D) to good chassis ground, away from fuel tank and battery.

TO REMOVE CABLES, REVERSE ORDER -

- BLACK cable first from chassis and then from the fully charged battery.
- RED cable last from both batteries.

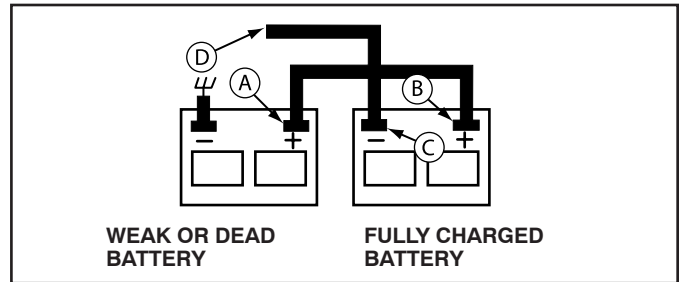

FIG. 33

TO REPLACE HEADLIGHT BULB

- Raise hood.
- Pull bulb holder out of the hole in the backside of the grill.
- Replace bulb in holder and push bulb holder securely back into the hole in the backside of the grill.
- Close hood.

INTERLOCKS AND RELAYS

Loose or damaged wiring may cause your tractor to run poorly, stop running, or prevent it from starting.

- Check wiring. See electrical wiring diagram in the Repair Parts section.

TO REPLACE FUSE

Replace with 20 amp automotive-type plug-in fuse. The fuse holder is located behind the dash.

TO REMOVE HOOD AND GRILL ASSEMBLY (See Fig. 34)

- Raise hood.
- Unsnap headlight wire connector.
- Stand in front of tractor. Grasp hood at sides, tilt toward engine and lift off of tractor.
- To replace, reverse above procedure.

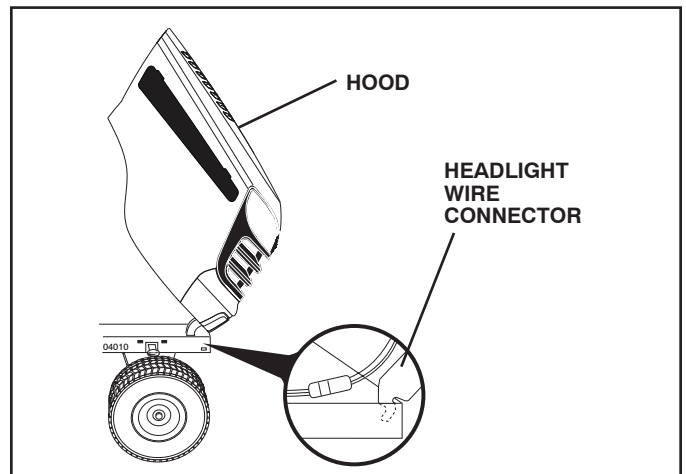

FIG. 34

SERVICE AND ADJUSTMENTS

ENGINE

Maintenance, repair, or replacement of the emission control devices and systems, which are being done at the customer's expense, may be performed by any non-road engine repair establishment or individual. Warranty repairs must be performed by an authorized engine manufacturer's service outlet.

TO ADJUST THROTTLE CONTROL CABLE (See Fig. 35)

The throttle control has been preset at the factory and adjustment should not be necessary. Check adjustment as described below before loosening cable. If adjustment is necessary, proceed as follows:

- With engine not running, move throttle control lever from slow to choke position. Slowly move lever from choke to fast position.
- Check that holes "A" in governor control lever and hole in governor plate line-up. If holes "A" are not aligned, loosen clamp screw and move throttle cable until holes are aligned. Tighten clamp screw securely.

TO ADJUST CARBURETOR (See Fig. 36)

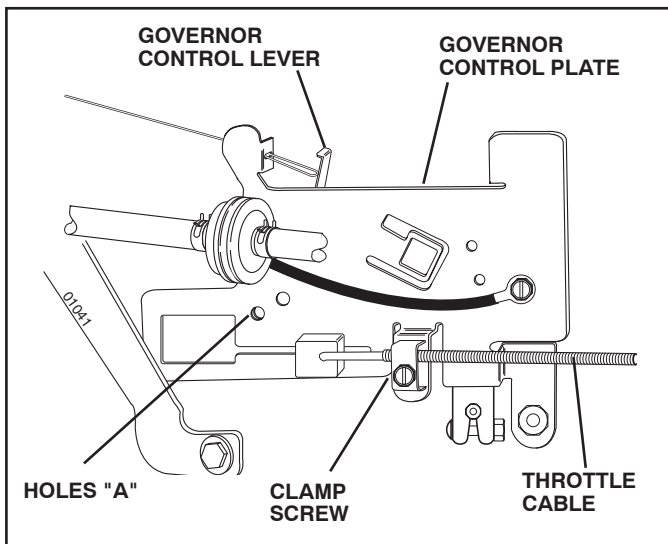

FIG. 35

NOTE: The carburetor on this engine is low emission. It is equipped with an idle fuel adjusting needle with a limiter cap, which allows some adjustment within the limits allowed by the cap. Do not attempt to remove the limiter cap. The limiter cap cannot be removed without breaking the adjusting needle.

The carburetor has been preset at the factory and adjustment should not be necessary. However, minor adjustment may be required to compensate for differences in fuel, temperature, altitude or load. If the carburetor does need adjustment, proceed as follows:

In general, turning idle mixture valve **in** (clockwise) decreases the supply of fuel to the engine giving a leaner fuel/air mixture. Turning the idle mixture valve **out** (counterclockwise) increases the supply of fuel to the engine giving a richer fuel/air mixture.

IMPORTANT: DAMAGE TO THE NEEDLE VALVE AND THE SEAT IN CARBURETOR MAY RESULT IF SCREW IS TURNED IN TOO TIGHT.

PRELIMINARY SETTING -

- Air cleaner assembly must be assembled to the carburetor when making carburetor adjustments.
- Be sure the throttle control cable is adjusted properly (see above).

FINAL SETTING -

- Start engine and allow to warm for five minutes. Make final adjustments with engine running and shift/motion control lever in neutral (**N**) position.
- Move throttle control lever to slow position. With finger, rotate and hold throttle lever against idle speed screw. Turn idle speed screw to attain 1750 RPM.
- While still holding throttle lever against idle speed screw, turn idle mixture valve full travel clockwise then counterclockwise until engine runs rough. Turn valve to a point midway between those two positions. Release throttle lever.

ACCELERATION TEST -

- Move throttle control lever from slow to fast position. If engine hesitates or dies, turn idle mixture valve **out** (counterclockwise) 1/8 turn. Repeat test and continue to adjust, if necessary, until engine accelerates smoothly.

High speed stop is factory adjusted. Do not adjust - damage may result.

IMPORTANT: NEVER TAMPER WITH THE ENGINE GOVERNOR, WHICH IS FACTORY SET FOR PROPER ENGINE SPEED. OVERSPEEDING THE ENGINE ABOVE THE FACTORY HIGH SPEED SETTING CAN BE DANGEROUS. IF YOU THINK THE ENGINE-GOVERNED HIGH SPEED NEEDS ADJUSTING, CONTACT YOUR NEAREST AUTHORIZED SERVICE CENTER/DEPARTMENT, WHICH HAS PROPER EQUIPMENT AND EXPERIENCE TO MAKE ANY NECESSARY ADJUSTMENTS.

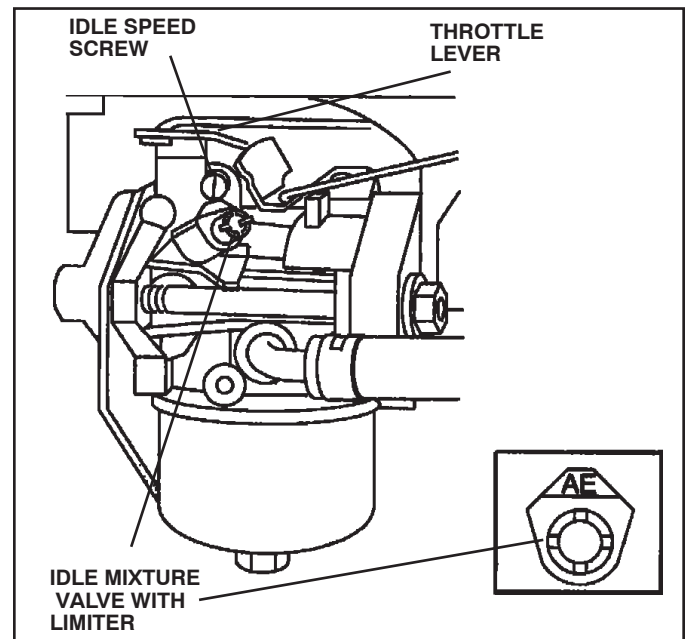

FIG. 36

STORAGE

Immediately prepare your tractor for storage at the end of the season or if the tractor will not be used for 30 days or more.



WARNING: Never store the tractor with gasoline in the tank inside a building where fumes may reach an open flame or spark. Allow the engine to cool before storing in any enclosure.

TRACTOR

Remove mower from tractor for winter storage. When mower is to be stored for a period of time, clean it thoroughly, remove all dirt, grease, leaves, etc. Store in a clean, dry area.

- Clean entire tractor (See “CLEANING” in the Maintenance section of this manual).
- Inspect and replace belts, if necessary (See belt replacement instructions in the Service and Adjustments section of this manual).
- Lubricate as shown in the Maintenance section of this manual.
- Be sure that all nuts, bolts and screws are securely fastened. Inspect moving parts for damage, breakage and wear. Replace if necessary.
- Touch up all rusted or chipped paint surfaces; sand lightly before painting.

BATTERY

- Fully charge the battery for storage.
- After a period of time in storage, battery may require recharging.
- To help prevent corrosion and power leakage during long periods of storage, battery cables should be disconnected and battery cleaned thoroughly (see “TO CLEAN BATTERY AND TERMINALS” in the Maintenance section of this manual).
- After cleaning, leave cables disconnected and place cables where they cannot come in contact with battery terminals.
- If battery is removed from tractor for storage, do not store battery directly on concrete or damp surfaces.

ENGINE

FUEL SYSTEM

IMPORTANT: IT IS IMPORTANT TO PREVENT GUM DEPOSITS FROM FORMING IN ESSENTIAL FUEL SYSTEM PARTS SUCH AS CARBURETOR, FUEL FILTER, FUEL HOSE, OR TANK DURING STORAGE. ALSO, EXPERIENCE INDICATES THAT ALCOHOL BLENDED FUELS (CALLED GASOHOL OR USING ETHANOL OR METHANOL) CAN ATTRACT MOISTURE WHICH LEADS TO SEPARATION AND FORMATION OF ACIDS DURING STORAGE. ACIDIC GAS CAN DAMAGE THE FUEL SYSTEM OF AN ENGINE WHILE IN STORAGE.

- Empty the fuel tank by starting the engine and let it run until the fuel lines and carburetor are empty.
- Never use engine or carburetor cleaner products in the fuel tank or permanent damage may occur.
- Use fresh fuel next season.

NOTE: Fuel stabilizer is an acceptable alternative in minimizing the formation of fuel gum deposits during storage. Add stabilizer to gasoline in fuel tank or storage container. Always follow the mix ratio found on stabilizer container. Run engine at least 10 minutes after adding stabilizer to allow the stabilizer to reach the carburetor. Do not empty the gas tank and carburetor if using fuel stabilizer.

ENGINE OIL

Drain oil (with engine warm) and replace with clean engine oil. (See “ENGINE” in the Maintenance section of this manual).

CYLINDER(S)

- Remove spark plug(s).
- Pour one ounce of oil through spark plug hole(s) into cylinder(s).
- Turn ignition key to “START” position for a few seconds to distribute oil.
- Replace with new spark plug(s).

OTHER

- Do not store gasoline from one season to another.
- Replace your gasoline can if your can starts to rust. Rust and/or dirt in your gasoline will cause problems.
- If possible, store your tractor indoors and cover it to give protection from dust and dirt.
- Cover your tractor with a suitable protective cover that does not retain moisture. Do not use plastic. Plastic cannot breathe which allows condensation to form and will cause your tractor to rust.

IMPORTANT: NEVER COVER TRACTOR WHILE ENGINE AND EXHAUST AREAS ARE STILL WARM.

TROUBLESHOOTING POINTS

PROBLEM	CAUSE	CORRECTION
Will not start	<ol style="list-style-type: none"> 1. Out of fuel. 2. Engine not "CHOKED" properly. 3. Engine flooded. 4. Bad spark plug. 5. Weak or dead battery. 6. Dirty air filter. 7. Dirty fuel filter. 8. Water in fuel. 9. Loose or damaged wiring. 10. Carburetor out of adjustment. 11. Engine valves out of adjustment. 	<ol style="list-style-type: none"> 1. Fill fuel tank. 2. See "TO START ENGINE" in Operation section. 3. Wait several minutes before attempting to start. 4. Replace spark plug. 5. Recharge or replace battery. 6. Clean/replace air filter. 7. Replace fuel filter. 8. Empty fuel tank and carburetor, refill tank with fresh gasoline and replace fuel filter. 9. Check all wiring. 10. See "To Adjust Carburetor" in Service Adjustments section. 11. Contact an authorized service center/department.
Hard to start	<ol style="list-style-type: none"> 1. Dirty air filter. 2. Bad spark plug. 3. Weak or dead battery. 4. Dirty fuel filter. 5. Stale or dirty fuel. 6. Loose or damaged wiring. 7. Carburetor out of adjustment. 8. Engine valves out of adjustment. 	<ol style="list-style-type: none"> 1. Clean/replace air filter. 2. Replace spark plug. 3. Recharge or replace battery. 4. Replace fuel filter. 5. Empty fuel tank and refill tank with fresh, clean gasoline. 6. Check all wiring. 7. See "To Adjust Carburetor" in Service Adjustments section. 8. Contact an authorized service center/department.
Engine will not turn over	<ol style="list-style-type: none"> 1. Brake pedal not depressed. 2. Attachment clutch is engaged. 3. Weak or dead battery. 4. Blown fuse. 5. Corroded battery terminals. 6. Loose or damaged wiring. 7. Faulty ignition switch. 8. Faulty solenoid or starter. 9. Faulty operator presence switch(es). 	<ol style="list-style-type: none"> 1. Depress brake pedal. 2. Disengage attachment clutch. 3. Recharge or replace battery. 4. Replace fuse. 5. Clean battery terminals. 6. Check all wiring. 7. Check/replace ignition switch. 8. Check/replace solenoid or starter. 9. Contact an authorized service center/department.
Engine clicks but will not start	<ol style="list-style-type: none"> 1. Weak or dead battery. 2. Corroded battery terminals. 3. Loose or damaged wiring. 4. Faulty solenoid or starter. 	<ol style="list-style-type: none"> 1. Recharge or replace battery. 2. Clean battery terminals. 3. Check all wiring. 4. Check/replace solenoid or starter.
Loss of power	<ol style="list-style-type: none"> 1. Cutting too much grass/too fast. 2. Throttle in "CHOKE" position. 3. Build-up of grass, leaves and trash under mower. 4. Dirty air filter. 5. Low oil level/dirty oil. 6. Faulty spark plug. 7. Dirty fuel filter. 8. Stale or dirty fuel. 9. Water in fuel. 10. Spark plug wire loose. 11. Dirty engine air screen/fins. 12. Dirty/clogged muffler. 13. Loose or damaged wiring. 14. Carburetor out of adjustment. 15. Engine valves out of adjustment. 	<ol style="list-style-type: none"> 1. Raise cutting height/reduce speed. 2. Adjust throttle control. 3. Clean underside of mower housing. 4. Clean/replace air filter. 5. Check oil level/change oil. 6. Clean and regap or change spark plug. 7. Replace fuel filter. 8. Empty fuel tank and refill tank with fresh, clean gasoline. 9. Empty fuel tank and carburetor, refill tank with fresh gasoline and replace fuel filter. 10. Connect and tighten spark plug wire. 11. Clean engine air screen/fins. 12. Clean/replace muffler. 13. Check all wiring. 14. See "To Adjust Carburetor" in Service Adjustments section. 15. Contact an authorized service center/department.
Excessive vibration	<ol style="list-style-type: none"> 1. Worn, bent or loose blade. 2. Bent blade mandrel. 3. Loose/damaged part(s). 	<ol style="list-style-type: none"> 1. Replace blade. Tighten blade bolt. 2. Replace blade mandrel. 3. Tighten loose part(s). Replace damaged parts.

TROUBLESHOOTING POINTS

PROBLEM	CAUSE	CORRECTION
Engine dies when tractor is shifted into reverse	<ol style="list-style-type: none"> Reverse operation system (ROS) is not "ON" while mower or other attachment is engaged. 	<ol style="list-style-type: none"> Turn ignition key to ROS "ON" position. See Operation section.
Engine continues to run when operator leaves seat with attachment clutch engaged	<ol style="list-style-type: none"> Faulty operator-safety presence control system. 	<ol style="list-style-type: none"> Check wiring, switches and connections. If not corrected, contact an authorized service center/department.
Poor cut - uneven	<ol style="list-style-type: none"> Worn, bent or loose blade. Mower deck not level. Buildup of grass, leaves, and trash under mower. Bent blade mandrel. Clogged mower deck vent holes from buildup of grass, leaves, and trash around mandrels. 	<ol style="list-style-type: none"> Replace blade. Tighten blade bolt. Level mower deck. Clean underside of mower housing. Replace blade mandrel. Clean around mandrels to open vent holes.
Mower blades will not rotate	<ol style="list-style-type: none"> Obstruction in clutch mechanism. Worn/damaged mower drive belt. Frozen idler pulley. Frozen blade mandrel. 	<ol style="list-style-type: none"> Remove obstruction. Replace mower drive belt. Replace idler pulley. Replace blade mandrel.
Poor grass discharge	<ol style="list-style-type: none"> Engine speed too slow. Travel speed too fast. Wet grass. Mower deck not level. Low/uneven tire air pressure. Worn, bent or loose blade. Buildup of grass, leaves and trash under mower. Mower drive belt worn. Blades improperly installed. Improper blades used. Clogged mower deck vent holes from buildup of grass, leaves, and trash around mandrels. 	<ol style="list-style-type: none"> Place throttle control in "FAST" position. Shift to slower speed. Allow grass to dry before mowing. Level mower deck. Check tires for proper air pressure. Replace blade. Tighten blade bolt. Clean underside of mower housing. Replace mower drive belt. Reinstall blades sharp edge down. Replace with blades listed in this manual. Clean around mandrels to open vent holes.
Headlight(s) not working (if so equipped)	<ol style="list-style-type: none"> Light switch is "OFF". Bulb(s) or lamp(s) burned out. Faulty light switch. Loose or damaged wiring. Blown fuse. 	<ol style="list-style-type: none"> Turn light switch "ON". Replace bulb(s) or lamp(s). Check/replace light switch. Check wiring and connections. Replace fuse.
Battery will not charge	<ol style="list-style-type: none"> Bad battery cell(s). Poor cable connections. Faulty regulator (if so equipped). Faulty alternator. 	<ol style="list-style-type: none"> Replace battery. Check/clean all connections. Replace regulator. Replace alternator.
Loss of drive	<ol style="list-style-type: none"> Freewheel control in "disengaged" position. Motion drive belt worn, damaged, or broken. Air trapped in transmission during shipment or servicing. 	<ol style="list-style-type: none"> Place freewheel control in "engaged" position. Replace motion drive belt. Purge transmission.
Engine "backfires" when turning engine "OFF"	<ol style="list-style-type: none"> Engine throttle control not set between half and full speed (fast) position before stopping engine. 	<ol style="list-style-type: none"> Move throttle control between half and full speed (fast) position before stopping engine.

TRACTOR - - MODEL NUMBER 944.607930

SCHEMATIC

SCH11

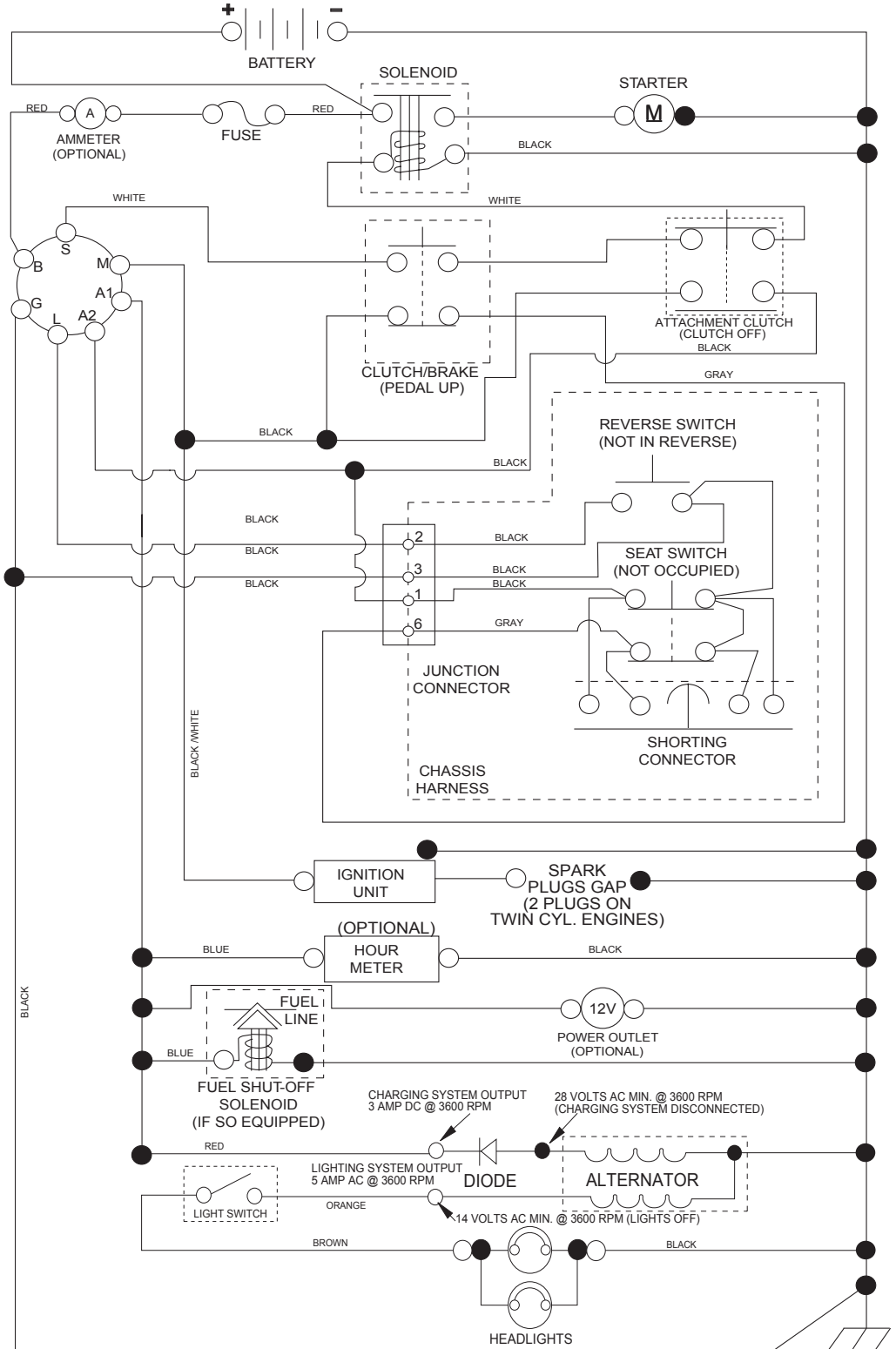

NOTE
YOUR TRACTOR IS EQUIPPED WITH A SPECIAL ALTERNATOR SYSTEM. THE LIGHTS ARE NOT CONNECTED TO THE BATTERY, BUT HAVE THEIR OWN ELECTRICAL SOURCE. BECAUSE OF THIS, THE BRIGHTNESS OF THE LIGHTS WILL CHANGE WITH ENGINE SPEED. AT IDLE THE LIGHTS WILL DIM. AS THE ENGINE IS SPEEDED UP, THE LIGHTS WILL BECOME THEIR BRIGHTEST.

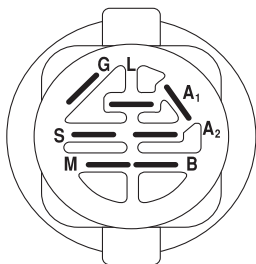

IGNITION SWITCH

POSITION	CIRCUIT	"MAKE"
OFF	M+G+A1	
RUN/OVERRIDE	B+A1	
RUN	B+A1	L+A2
START	B + S + A1	

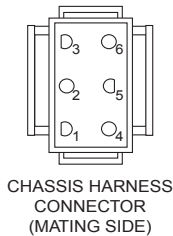

CHASSIS HARNESS CONNECTOR (MATING SIDE)

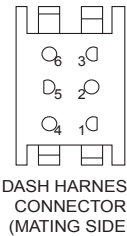

DASH HARNESS CONNECTOR (MATING SIDE)

WIRING INSULATED CLIPS
NOTE: IF WIRING INSULATED CLIPS WERE REMOVED FOR SERVICING OF UNIT, THEY SHOULD BE RE-INSTALLED TO PROPERLY SECURE YOUR WIRING.



TRACTOR - - MODEL NUMBER 944.607930

ELECTRICAL

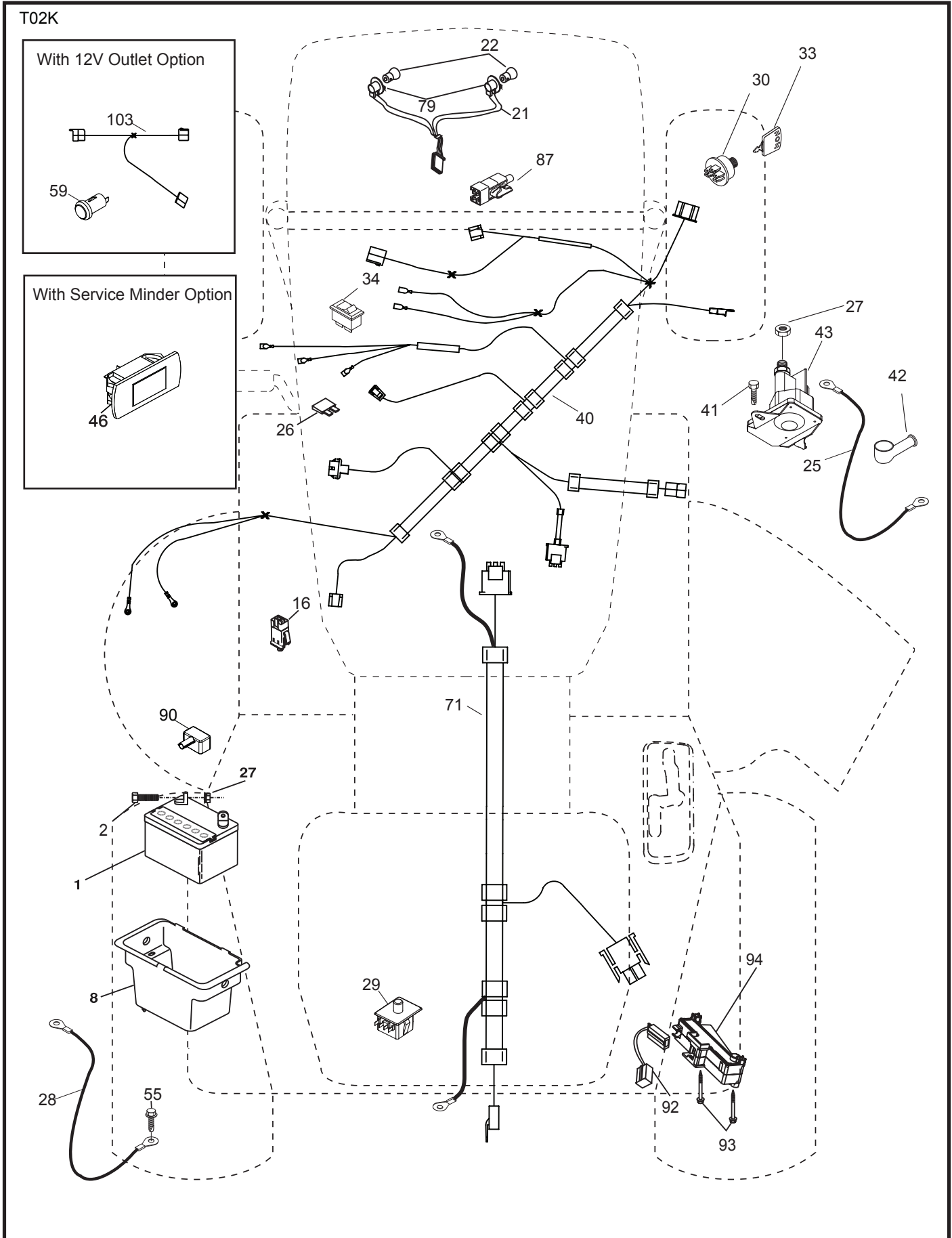

TRACTOR - - MODEL NUMBER 944.607930

ELECTRICAL

KEY NO.	PART NO.	DESCRIPTION
1	163465	Battery
2	74760412	Bolt Hex Hd 1/4-20 unc x 3/4
8	193228	Box Battery
16	176138	Switch Interlock Push-In
21	400252	Harness Socket Light W/4152J
22	4152J	Bulb Light
25	412894	Cable Starter
26	175158	Fuse
27	73510400	Nut Keps Hex 1/4-20 unc
28	198885	Cable, Ground
29	192749	Switch, Seat
30	193350	Switch, Ign
33	140403	Key, Ignition
34	110712X	Switch Light / Reset
40	401098	Harness Ign. Dash
41	17720408	Screw Thd Cut 1/4-20 x 1/2
42	131563	Cover, Terminal
43	192507	Solenoid
55	17060512	Screw Thdrol 5/16-18 x 3/4 TYTT
71	400449	Harness Ign.
79	175242	Bulbholder Asm. Incan Descent
87	197802	Switch interlock
90	400725	Cover Terminal Battery
92	196615	Harness Pigtail
93	192540	Screw Plastite 10-14 x 2.0
94	191834	Module Reverse ROS

NOTE: All component dimensions given in U.S. inches
1 inch = 25.4 mm

TRACTOR - - MODEL NUMBER 944.607930

CHASSIS

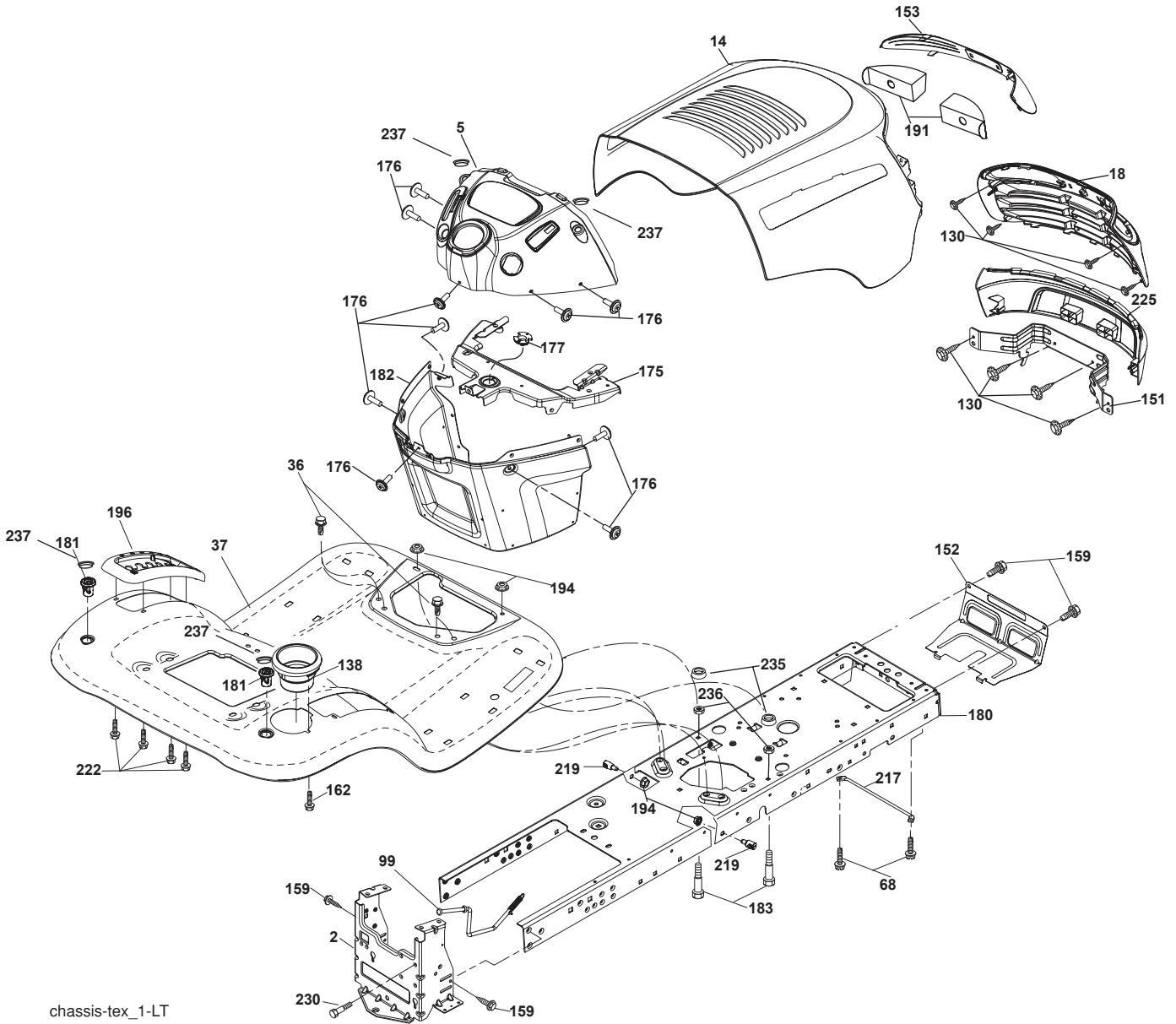

TRACTOR - - MODEL NUMBER 944.607930

CHASSIS

KEY NO.	PART NO.	DESCRIPTION
2	194263	Drawbar
5	400801X428	Dash
14	197665X615	Hood
18	400551	Grille
36	17060512	Screw 5/16-18 x 3/4
37	193218X615	Fender
68	17490508	Screw Thdrol 5/16-18 x 1/2
99	403376	Rod Asm Bypass
130	191611	Screw 10 x 3/4 Single Lead-Hex
138	193224X428	Cupholder
151	187568	Bracket Pivot
152	194329	Shield Browning/Debris
153	400550X599	Lens Bar
159	17000612	Screw Hexwsh Thdrol 3/8-16 x 3/4
162	142432	Screw Hex Wsh Hi-Lo 1/4 x 1/2
175	199472	Crossmember
176	400776	Screw 10-24 x 5/8 Wshd Qdrx
177	195228	Bushing Steering
180	194260	Chassis
181	193102X428	Bushing Mtg. Fender Crgo.
182	198917	Dash Lower
183	74780520	Bolt Fin Hex 5/16-18 x 1-1/4
191	401827	Reflector Insert
194	73900500	Nut Lock Hex Flange 5/16-18
196	196378X428	Console Asm. Deck Lift
217	156524	Rod Pivot Chassis
219	195161	Stud Fastener
222	137729	Screw Thd Roll 1/4-20 x 5/8
225	400549X615	Bumper
230	170165	Bolt Shoulder 5/16-18
235	406129	Spacer Fender
236	73930500	Nut Center Lock 5/16-18
237	403704	Plug Mount Cargo

NOTE: All component dimensions given in U.S. inches
1 inch = 25.4 mm

TRACTOR - - MODEL NUMBER 944.607930

DRIVE

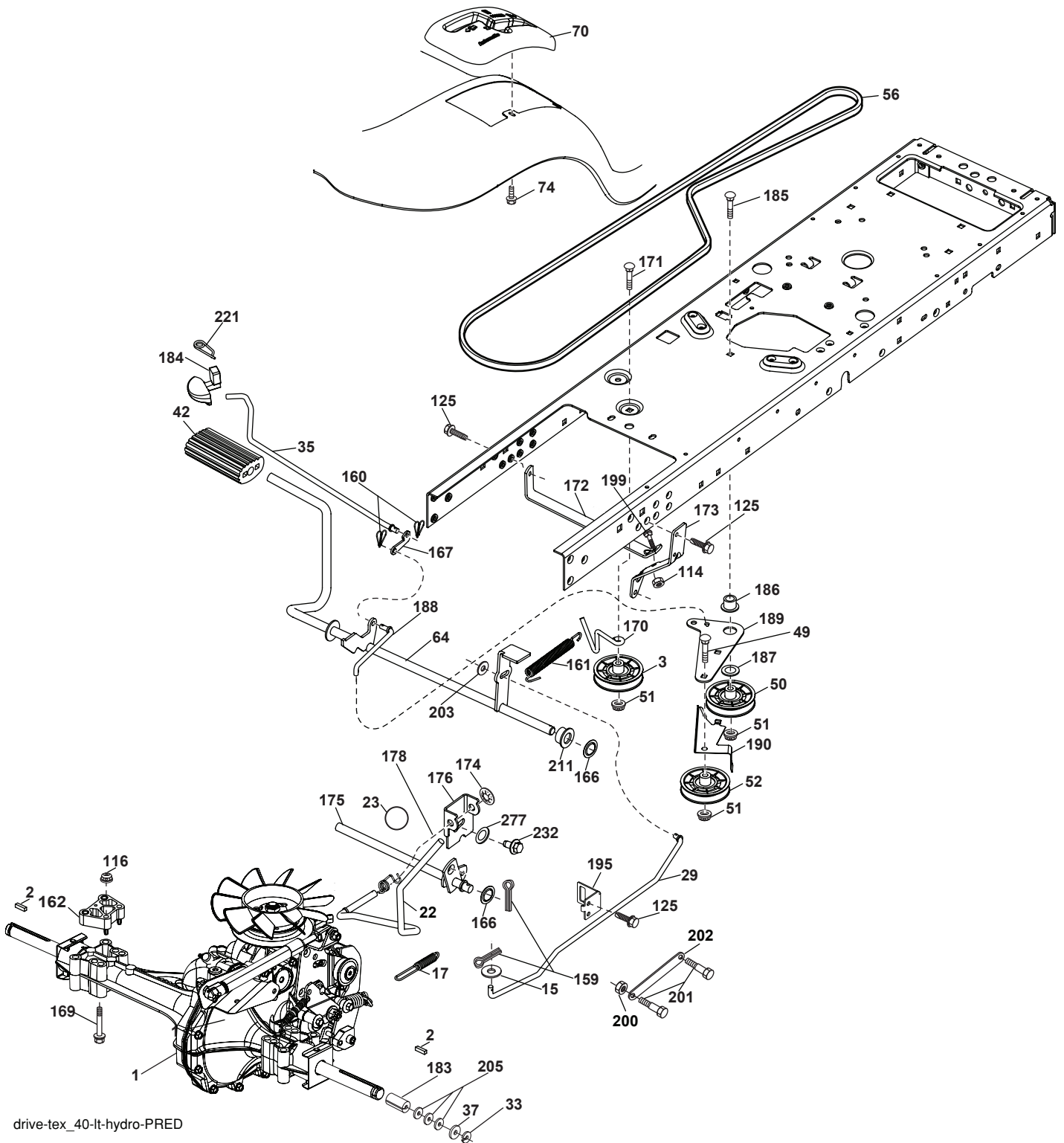

drive-tex_40-lt-hydro-PRED

TRACTOR - - MODEL NUMBER 944.607930

DRIVE

KEY NO.	PART NO.	DESCRIPTION	KEY NO.	PART NO.	DESCRIPTION
1	-----	Transaxle, Hydro Gear 0510 (See Transaxle Breakdown)	169	74490560	Bolt Hex 5/16-18x 3.75
2	123583X	Key Square	170	194322	Keeper Belt Centerspan
3	407287	Idler V-Groove	171	72110622	Bolt
15	19131316	Washer 13/32 x 13/16 x 16 Ga.	172	197656	Strap Torque LH
17	197296	Spring, Brake	173	197655	Strap Torque RH
22	197660	Rod Shift	174	197289	Nut Push
23	130564	Knob	175	197653	Shaft Asm Shift
29	197659	Rod, Brake	176	196214	Arm Clevis Rod Shift
33	12000001	Ring E	178	197456	Spring Shift
35	401031	Rod, Brake, Park	183	137057	Spacer Axle
37	121749X	Washer 25/32 x 1-1/4 x 16 Ga.	184	199996X505	Handle Parking Brake
42	8883R	Cover, Foot Pedal	185	72110620	Bolt
49	72110614	Bolt	186	194321	Spacer Retainer
50	194327	Pulley Idler Flat	187	19133210	Washer
51	73900600	Lock Nut 3/8-16	188	194323	Link Clutch Ground Drive
52	194326	Idler V-Groove 910" Offset	189	194317	Bellcrank Ground Drive
56	140218	V-Belt, Drive	190	194318	Keeper Bellcrank Ground Drive
64	196200	Shaft Asm. Pedal Brake Control	195	198012	Bracket Brake Rod
70	193220X428	Console	199	72140508	Bolt 5/16-18 UNC x 1
74	142432	Screw 1/4 x 1/2	200	73930500	Nut Center Lock 5/16-18 UNC
114	73800500	Nut Lock 5/16-18 unc	201	169612	Bolt Shoulder 5/16-18 UNC
116	73900500	Nut Lock Hex Flange 5/16-18	202	197715	Link Transaxle
125	17000512	Screw 5/16-18 x 3/4	203	19111116	Washer 11/32 x 11/16 x 16 Ga.
159	76020412	Pin Cotter 1/8 x 3/4	205	121748X	Washer 25/32 x 1-5/8 x 16 Ga.
160	169484	Retainer Clip	211	196212	Bushing
161	195403	Spring, Return, Clutch	221	403178	Retainer Spring Clip
162	195785	Spacer Transaxle	232	74780716	Bolt Fin Hex 7/16-14
166	197290	Nut Push .625	277	405296	Washer Serrated
167	405257	Latch Brake Parking			

NOTE: All component dimensions given in U.S. inches
1 inch = 25.4 mm

TRACTOR - - MODEL NUMBER 944.607930

ENGINE

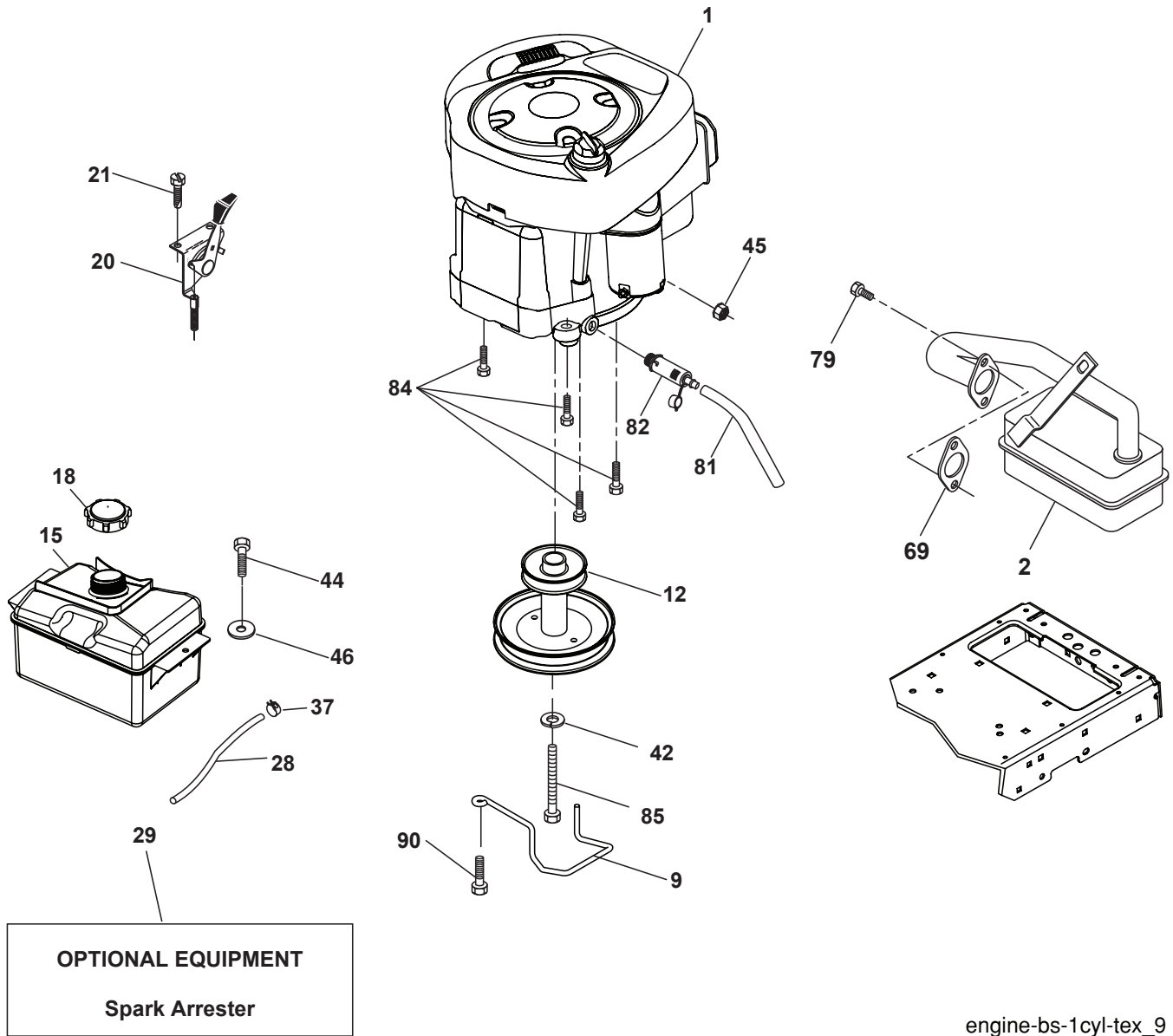

engine-bs-1cyl-tex_9

TRACTOR - - MODEL NUMBER 944.607930

ENGINE

KEY NO.	PART NO.	DESCRIPTION
1	-----	Engine B&S Model No. 31P977-0635-E1 (See Engine Breakdown)
2	137352	Muffler
9	194319	Keeper Belt Engine
12	401985	Pulley Engine
15	407545	Tank Fuel
18	197725	Cap Asm
20	176636X428	Control Throttle/Choke
21	191611	Screw 10 x 3/4 Single Lead-Hex
28	137040	Fuel Line
29	137180	Spark Arrester Kit
37	123487X	Clamp Hose
42	STD551143	Washer Lock 7/16
44	17670412	Screw Hexwsh Thdrol 1/4-20 x 3/4
45	73510400	Nut Keps Hex 1/4-20 unc
46	19091416	Washer 9/32 x 7/8 x 16
69	165291	Gasket
79	192334	Screw Socket Hd 5/16-18 x .75
81	148456	Tube Drain Oil Easy
82	181654	Plug Drain Oil
84	17060620	Screw 3/8-16 x 1-1/4
85	173937	Bolt Hex 7/16-20 x 4 x Gr. 5-1.5
90	17000616	Screw 3/8-16 x 1.0

NOTE: All component dimensions given in U.S. inches
1 inch = 25.4 mm

Engine Power Rating Information

The gross power rating for individual gas engine models is labeled in accordance with SAE (Society of Automotive Engineers) code J11940 (Small Engine Power & Torque Rating Procedure), and rating performance has been obtained and corrected in accordance with SAE J1995 (Revision 2002-5). Actual gross engine power will be lower and is affected by, among other things, ambient operating conditions and engine-to-engine variability. Given both the wide array of products on which engines are placed and the variety of environmental issues applicable to operating the equipment, the gas engine will not develop the rated gross power when used in a given piece of power equipment (actual "on-site" or net horsepower). This difference is due to a variety of factors including, but not limited to, accessories (air cleaner, exhaust, charging, cooling, carburetor, fuel pump, etc.), application limitations, ambient operating conditions (temperature, humidity, altitude), and engine-to-engine variability. Due to manufacturing and capacity limitations, Briggs & Stratton may substitute an engine of higher rated power for this Series engine.

TRACTOR - - MODEL NUMBER 944.607930

STEERING ASSEMBLY

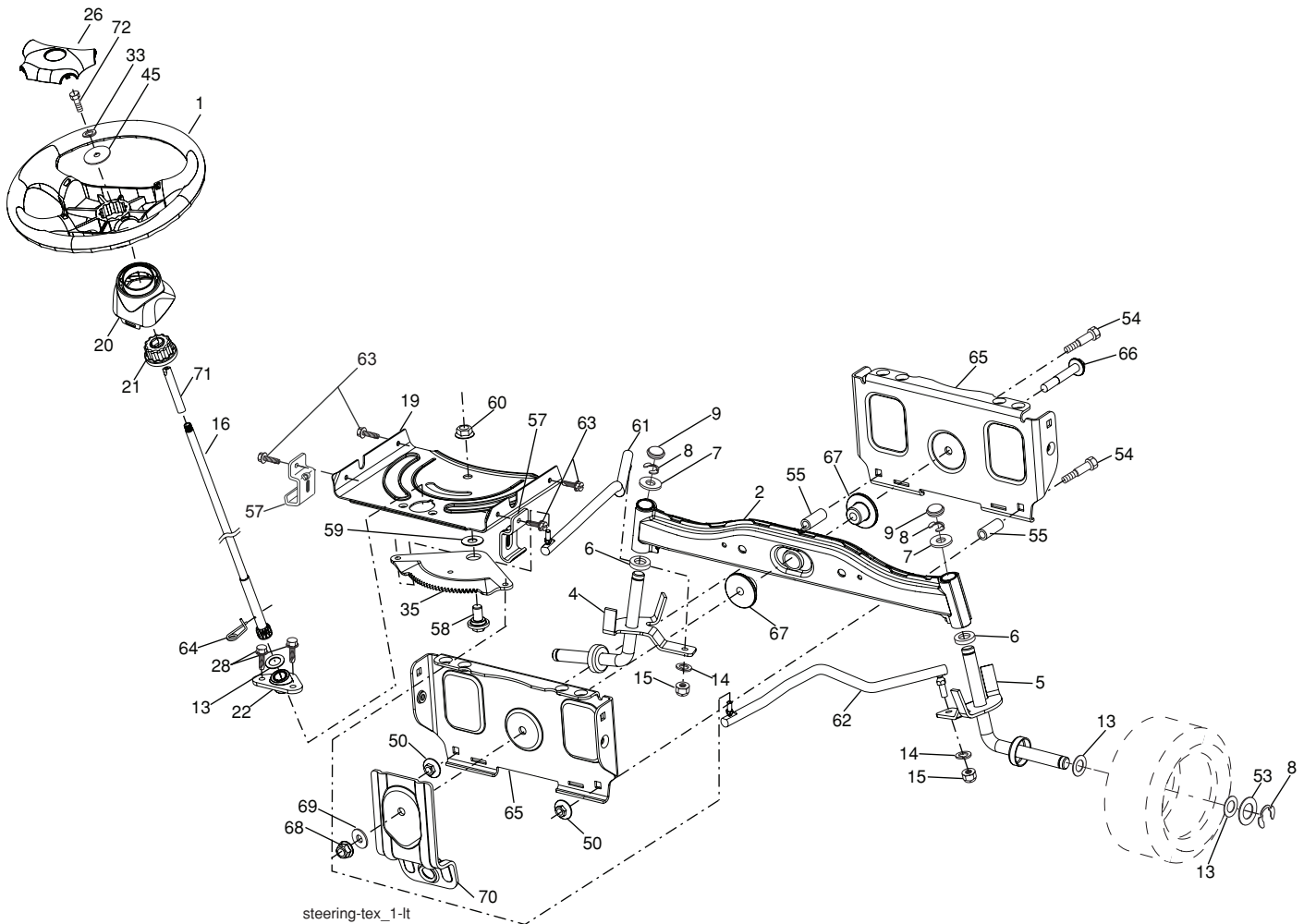

KEY NO.	PART NO.	DESCRIPTION
1	186093X428	Wheel, Steering
2	184706	Axle Asm., Front
4	403087	Spindle Asm., LH
5	403088	Spindle Asm., RH
6	6266H	Bearing, Race Thrust Harden
7	121748X	Washer 25/32 x 1-5/8 x 16 Ga.
8	12000029	Ring, Klip #T5304-75
9	184946X505	Cap, Spindle
13	121749X	Washer 25/32 x 1-1/4 x 16 Ga.
14	10040600	Washer, Lock Hvy Hlcl Spr 3/8
15	73540600	Nut, Crown Lock 3/8-24 unc
16	408220	Shaft Steering
19	194729	Plate Steering
20	400803X428	Boot, Steering
21	186737	Adapter, Wheel Steering
22	194845	Bushing, Strg. Blk
26	186095X428	Insert, Wheel Steering
28	17000612	Screw 3/8-16 x 3/4
33	10040500	Washer Lock HVY HLSPR 5/16
35	194732	Gear, Sector Plate
45	19183812	Washer 9/16 ID x 2-3/8 OD x 12 Ga.
50	73900600	Nut Lock 3/8-16 unc
53	188967	Washer Hardened .793 x 1.637 x .060

KEY NO.	PART NO.	DESCRIPTION
54	74760636	Bolt Hex 3/8-16 unc x 2-1/4
55	197636	Spacer Brace Axle
57	407465	Bracket Upstop
58	194747	Bolt Shoulder Sector Pivot CFM
59	194748	Washer Thrust Sector Steering
60	73971000	Nut Flange Lock 5/8-11
61	194740	Draglink LH
62	194741	Draglink, RH
63	17000512	Screw 5/16-18 x 3/4
64	199849	Retainer Clip Spring Steering
65	194734	Brace Axle Front
66	71020748	Bolt Hex Fghd 7/16-14 x 3 Serr
67	194737	Bushing PM Front Axle
68	73900700	Nut Lock Flange 7/16-14 Gr. 5
69	199162	Washer 1.5 x .505 x .118
70	196197	Bracket Deck Susp. Front
71	196075	Shaft Exten. Strg.
72	74780572	Bolt Fin Hex 5/16-18

NOTE: All component dimensions given in U.S. inches
1 inch = 25.4 mm

TRACTOR - - MODEL NUMBER 944.607930

SEAT ASSEMBLY

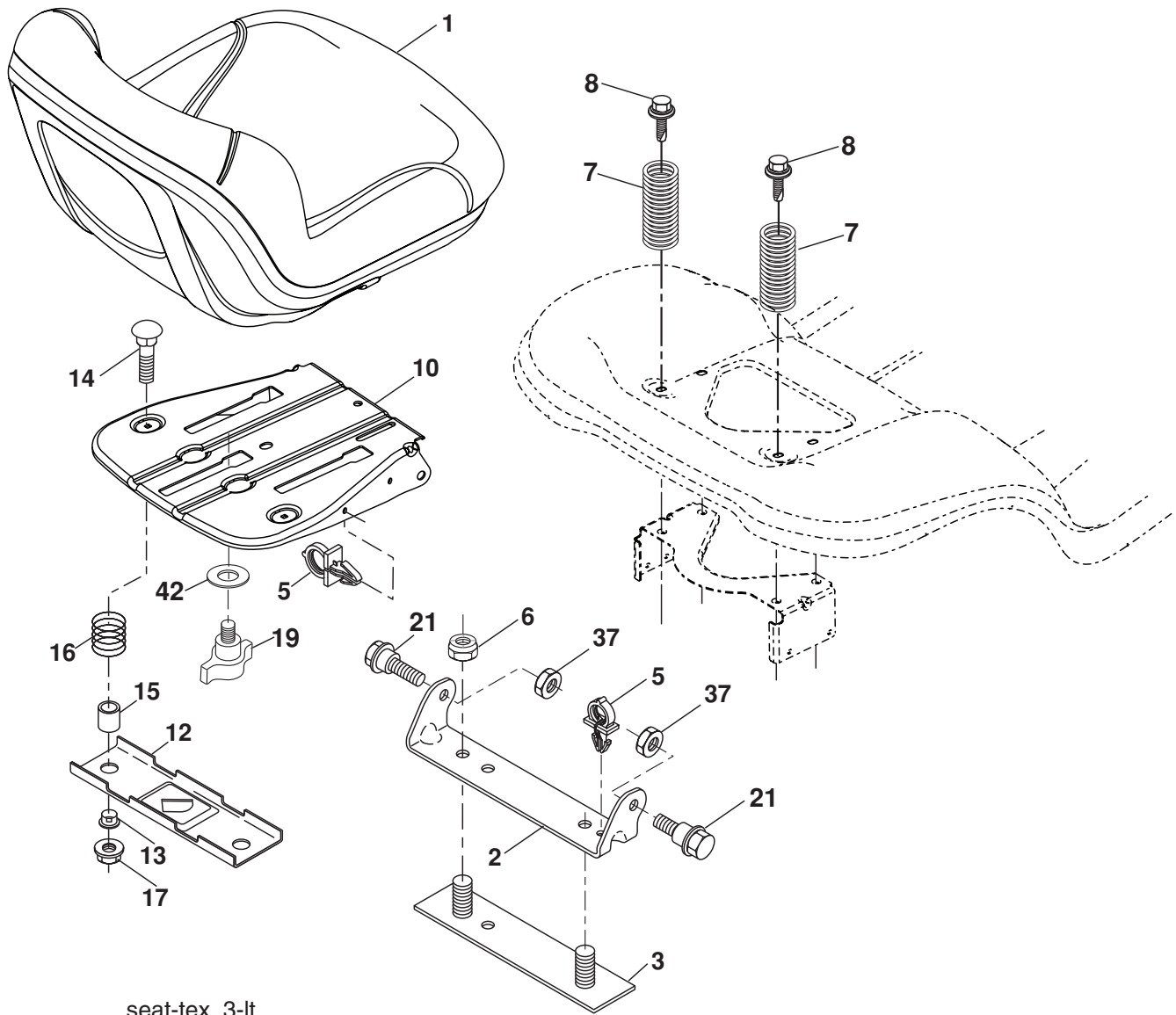

seat-tex_3-lt

KEY NO.	PART NO.	DESCRIPTION
1	197520	Seat
2	180166	Bracket Pivot Fender
3	140675	Strap, Asm Fender
5	145006	Clip, Push In, Hinged
6	73800600	Nut, Lock W/Ins. 3/8-16 unc
7	124181X	Spring, Seat Cprsn
8	171877	Bolt 5/16-18 uncx 3/4 w/Sems
10	199180	Pan, Seat
12	199370	Bracket Mnt Opc Seat
13	121248X	Bushing Snap
14	72050412	Bolt Rdhd Sh Nk 1/4-20 x 1-1/2

KEY NO.	PART NO.	DESCRIPTION
15	134300	Spacer Split .28 x .96
16	123740X	Spring
17	123976X	Nut Lock 1/4 Lrg Flg Gr. 5
19	199372	Knob Seat
21	171852	Bolt, Shoulder 5/16-18
37	73800500	Nut, Lock 5/16-18 unc
42	199371	Washer

NOTE: All component dimensions given in U.S. inches
1 inch = 25.4 mm

TRACTOR - - MODEL NUMBER 944.607930

MOWER DECK

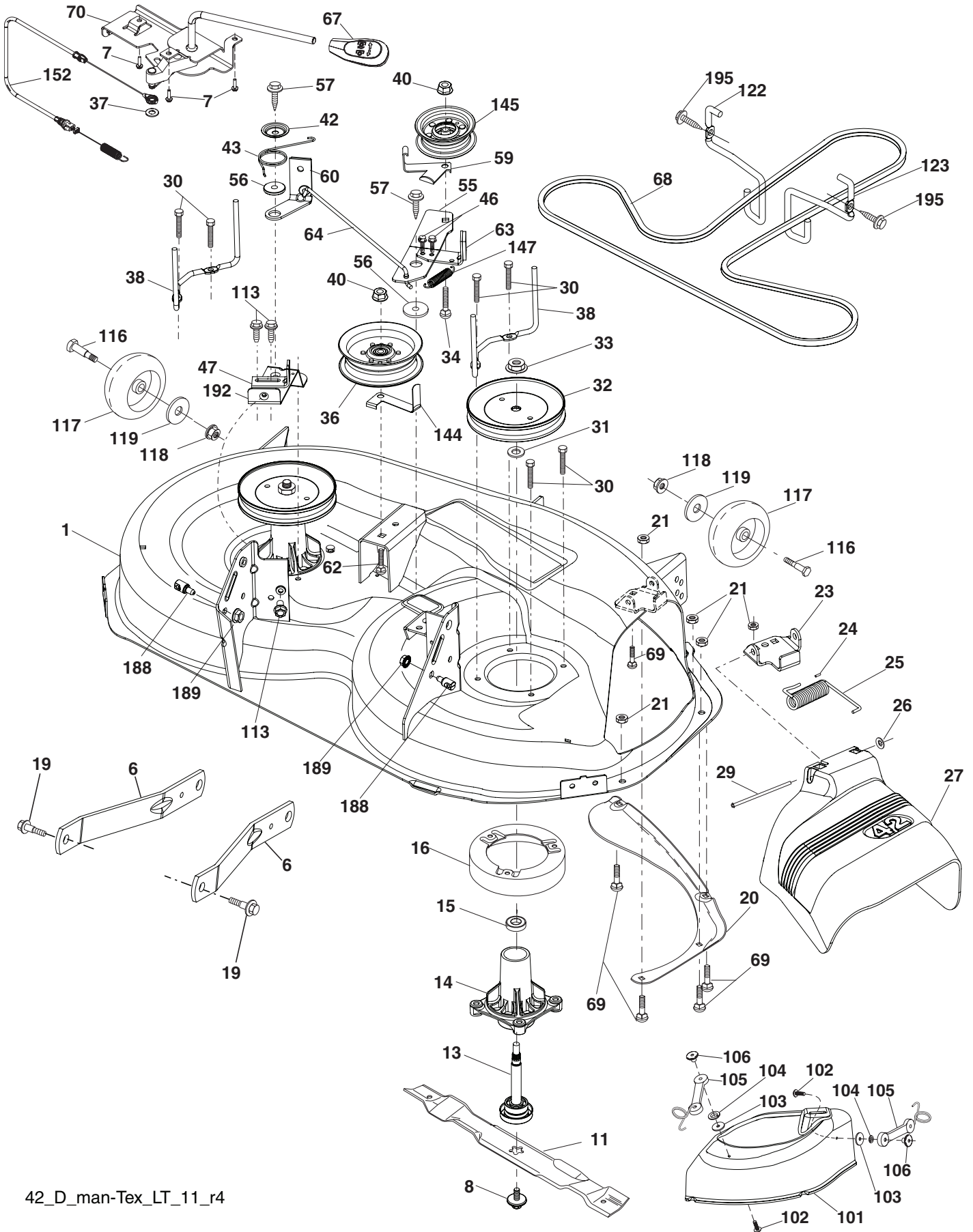

TRACTOR - - MODEL NUMBER 944.607930

MOWER DECK

KEY NO.	PART NO.	DESCRIPTION	KEY NO.	PART NO.	DESCRIPTION
1	196495	Deck Weldment Mower	60	197261	Arm Brake Mower
6	195186	Arm Suspension	62	72110616	Bolt Rd Hd Sq Nk 3/8-16 unc x 2
7	416358	Screw #10 x 0.750	63	199477	Arm Brake Mower
8	193003	Bolt/Washer asm 7/16-20 unf	64	199790	Link Brake Asm
11	134149	Blade, 42" Mulching Std (For mulching mowers only)	67	198398X505	Handle Clutch Cable
--	138971	Blade, 42" Hi-Lift (For bagging or discharge)	68	197253	V-Belt
--	139775	Blade, 42" Mulching Premium (For better wear when mulching)	69	72140505	Bolt
13	192872	Shaft Assembly, Mandrel	70	401246	Clutch Asm Manual
14	187281	Housing, Mandrel	101	193107	Cover Mulching
15	110485X	Bearing, Ball, Mandrel	102	71081010	Screw Pan Hd Phillips 10-24 x 5/8
16	174493	Stripper, Mower Deck	103	19061216	Washer #10
19	196539	Bolt, Shoulder	104	10071000	Washer Lock #10
20	159770	Baffle, Vortex	105	160793	Latch Asm
21	73680500	Nut, Crownlock 5/16-18 unc	106	2029J	Nut Weld .327-.304 #10-24
23	192557	Bracket, Deflector	113	17000510	Bolt 5/16-18
24	105304X	Cap, Sleeve	116	4898H	Bolt, Shoulder
25	197026	Spring, Torsion, Deflector	117	188606	Wheel, Gauge
26	110452X	Nut, Push	118	73930600	Nut, Crownlock 3/8-1
27	193108X428	Shield, Deflector	119	19121414	Washer 13/32 x 7/8 x 14 Ga.
29	131491	Rod, Hinge	122	197258	Keeper Belt Engine LH
30	173984	Screw Thdrol Rolling Wsh Hd	123	197259	Keeper Belt Engine RH
31	187690	Washer, Spacer	144	199204	Keeper Belt
32	197473	Pulley, Mandrel	145	193197	Pulley Idler
33	400234	Nut, Toplock, Flanged	147	401971	Spring Return
34	72110612	Bolt Carr Sh. 3/8-16 x 1-1/2 Gr. 5	152	408714	Cable Clutch Manual w/Spring
36	197379	Pulley, Idler, Flat	188	195161	Stud Fastener
37	19131316	Washer	189	73900500	Nut Lock Hex Flange
38	199189	Keeper Belt LH Mandrel	192	197260	Bracket Brake Stand LH
40	73900600	Nut, Lock Flg. 3/8-16 unc	195	17000612	Screw Hex Wsh Thdr 3/8-16 x 3/4
42	198410	Spring Torsion Brake	--	192870	Mandrel Assembly (Includes hous- ing, shaft assembly, and bearing only - pulley/nut/washer and blade bolt/washers not included)
43	197256	Spring Torsion Retainer	--	405126	Replacement Mower, Complete
46	137729	Screw Thd Roll 1/4-20 x 5/8			
47	197250	Bracket Clutch Cable			
55	197249	Arm, Idler			
56	199092	Spacer, Retainer			
57	17000616	Screw 3/8-16 x 1			
59	141043	Guard, Tuv Idler			

NOTE: All component dimensions given in U.S. inches
1 inch = 25.4 mm

TRACTOR - - MODEL NUMBER 944.607930

DECALS

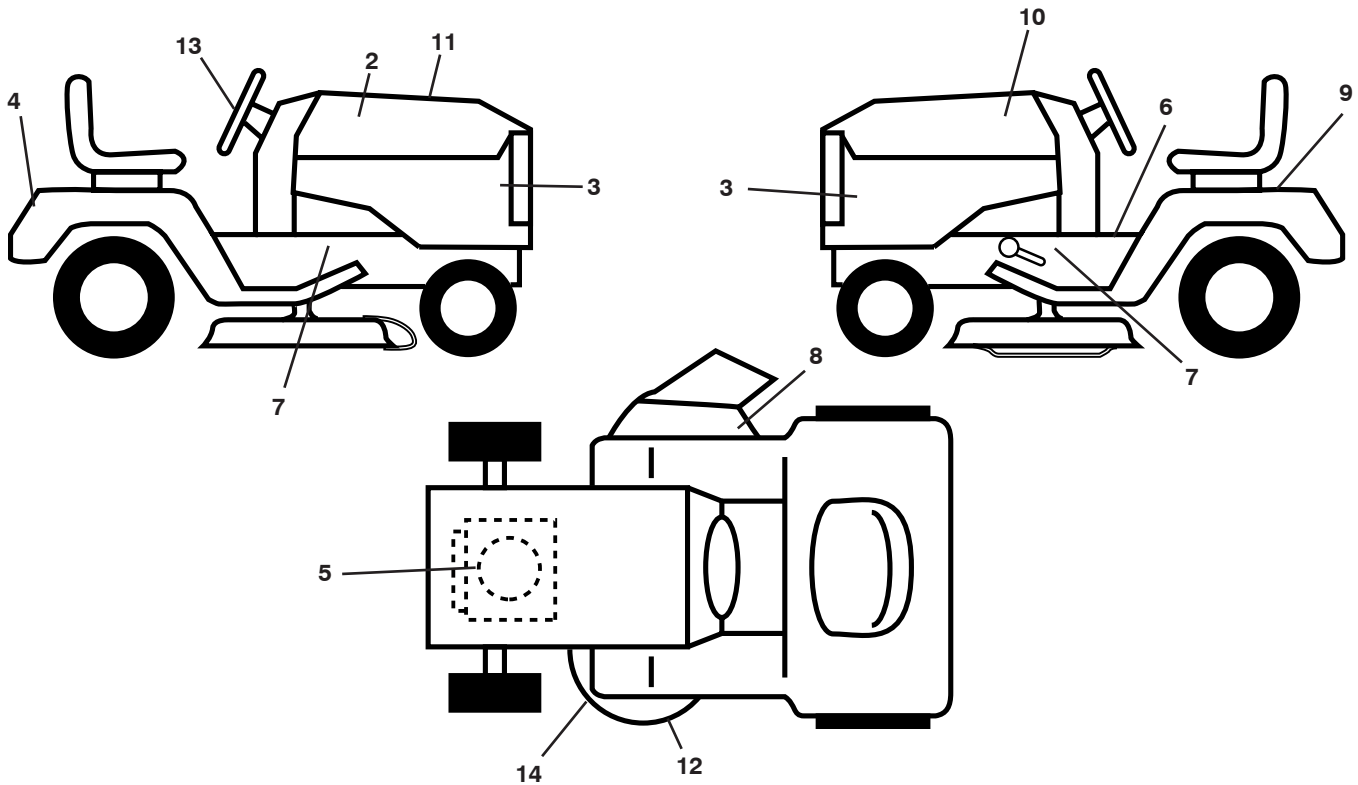

KEY NO.	PART NO.	DESCRIPTION
1	199135	Decal, Mower V-Belt Sch
2	412605	Decal, Hood RH
3	409079	Decal, Side Panel
4	411697	Decal, Fender
5	409460	Decal, Engine
6	199114	Decal, Fender Operator's
7	409080	Decal, Chas
8	170563	Decal, Warning
9	149517	Decal, Battery Dnge/Poi
10	412606	Decal, Hood LH

KEY NO.	PART NO.	DESCRIPTION
11	405123	Decal, Replacement
12	403870	Decal, Deck PRCSN
13	164065	Decal, Steering Wheel
14	160396	Decal, Mower Schematic
--	193227X428	Pad, Footrest, RH
--	166960	Decal, Bypass
--	193226X428	Pad, Footrest, LH
--	412558	Manual, Owner's English
--	412559	Manual, Owner's French

WHEELS AND TIRES

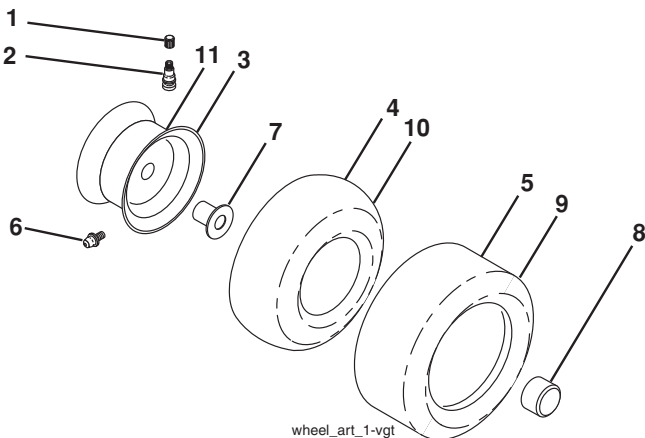

KEY NO.	PART NO.	DESCRIPTION
1	59192	Cap, Valve, Tire
2	65139	Stem, Valve
3	106732X645	Rim Assembly, Front
4	59904	Tube, Front
5	106222X	Tire, Front
6	278H	Fitting, Grease
7	9040H	Bearing, Flange
8	104757X645	Cap, Axle (Front Wheel Only)
9	106268X	Tire, Rear 18 x 9.5-8 TurfSaver
--	420531	Tire, Rear 18 x 9.5-8 TurfSaver LT
10	7152J	Tube, Rear
11	106108X645	Rim Assembly, Rear
--	144334	Sealant, Tire (10 oz. Tube)

NOTE: All component dimensions given in U.S. inches
1 inch = 25.4 mm

TRACTOR - - MODEL NUMBER 944.607930

MOWER LIFT

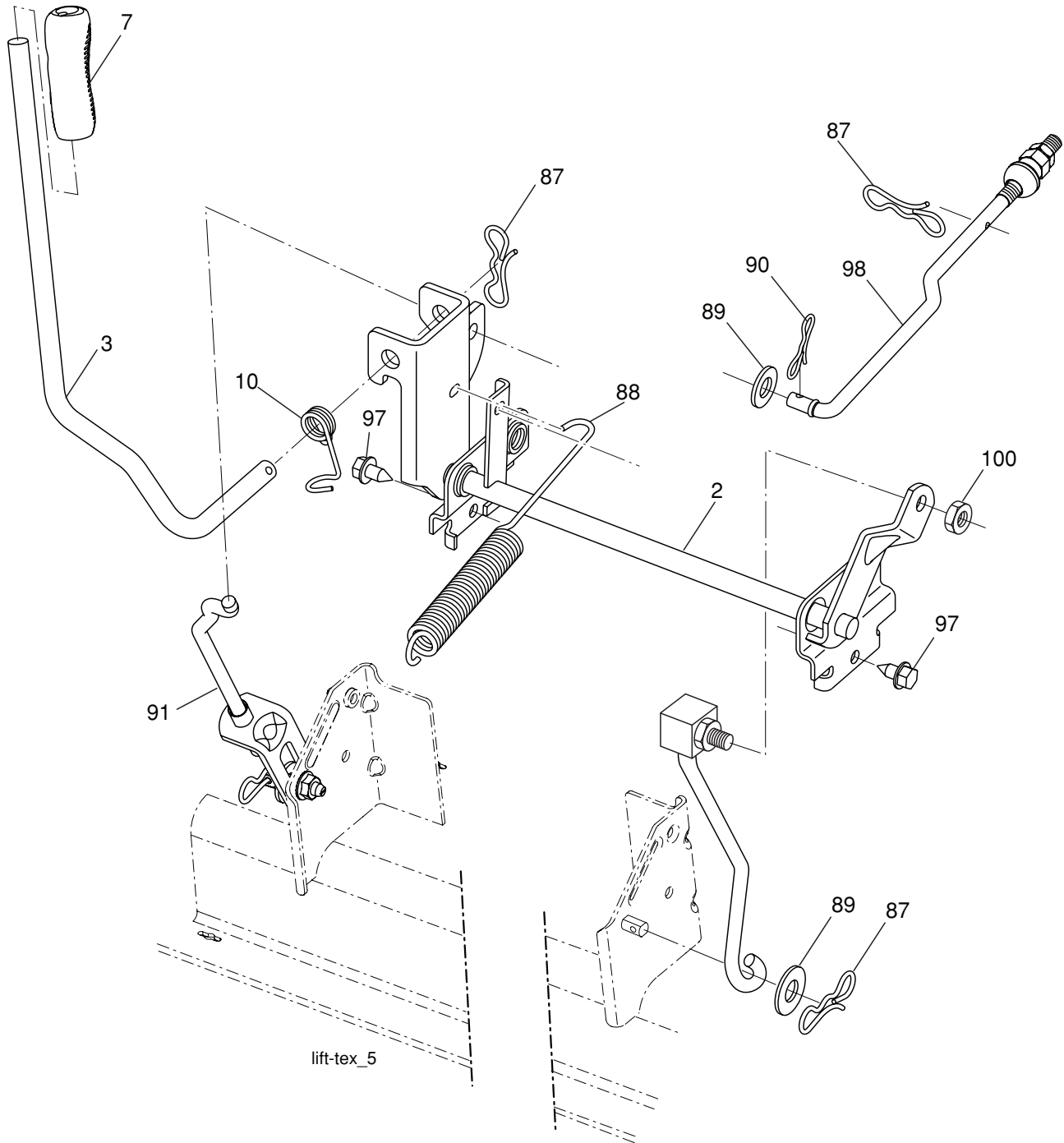

KEY NO.	PART NO.	DESCRIPTION
2	195223	Shaft Asm., Lift
3	195231	Lever Asm., Lift Rh
7	196492X428	Grip, Lever
10	196314	Spring Torsion
87	194209	Pin Cotter 7/16 Bow Tie Lock
88	410710	Spring Lift Assist
89	19191912	Washer Clear Zinc
90	194208	Pin Cotter 5/16 Bow Tie Lock

KEY NO.	PART NO.	DESCRIPTION
91	195181	Link Asm. Lift Rear
97	17060612	Screw 3/8-16 x .75 Smgml Tap/R.Z
98	195270	Link Lift Susp. Front Mower
100	73930600	Nut Centerlock 3/8-16

NOTE: All component dimensions given in U.S. inches
1 inch = 25.4 mm

TRACTOR - - MODEL NUMBER 944.607930

HYDRO TRANSAXLE - - MODEL NUMBER 351-0510

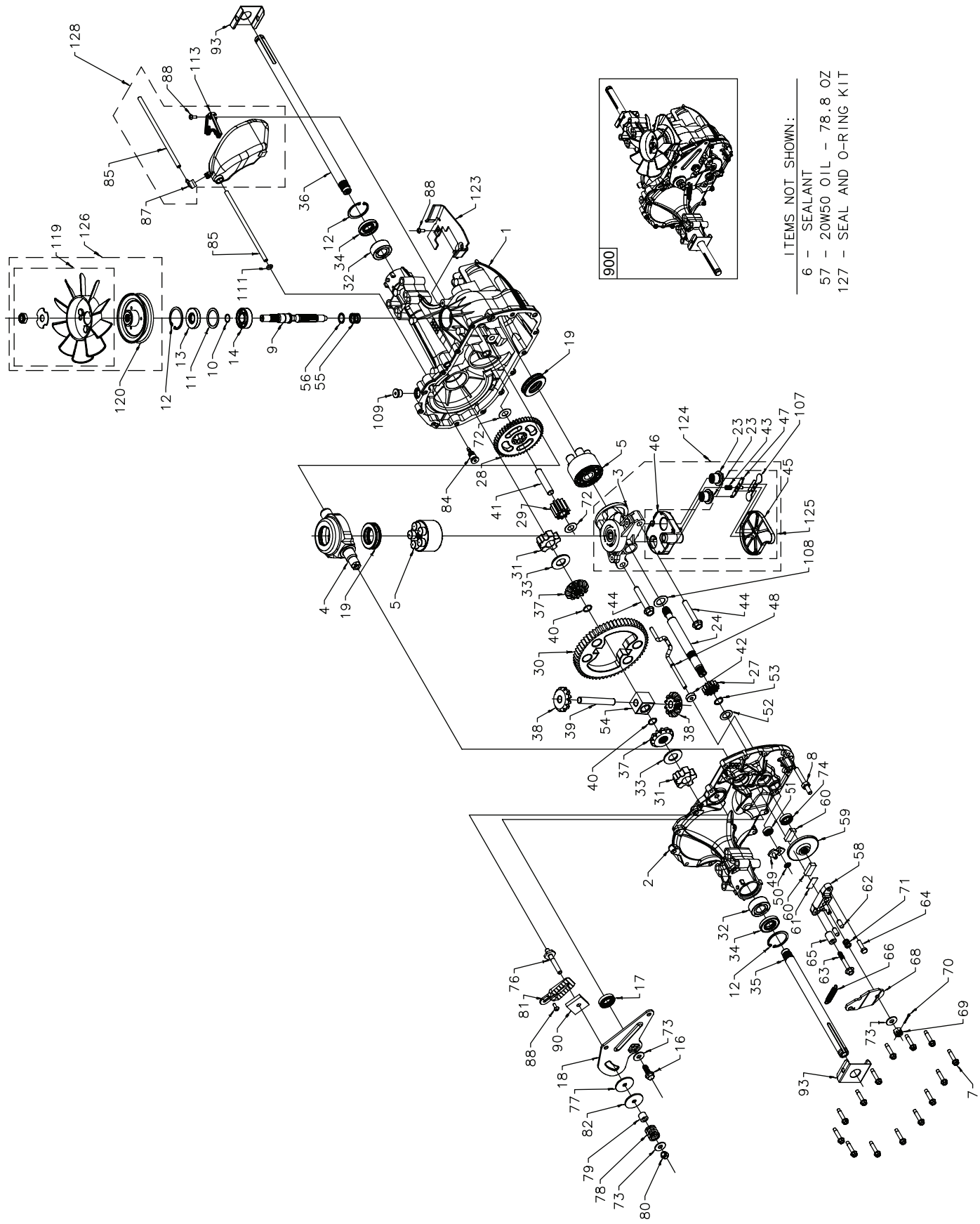

- ITEMS NOT SHOWN:
- 6 - SEALANT
 - 57 - 20W50 OIL - 78.8 OZ
 - 127 - SEAL AND O-RING KIT

TRACTOR - - MODEL NUMBER 944.607930

HYDRO TRANSAXLE - - MODEL NUMBER 351-0510

KEY NO.	PART NO.	DESCRIPTION	KEY NO.	PART NO.	DESCRIPTION
1	170351	Kit, Main Housing	68	401263	Arm-brake, RH
		Main Housing, Machined	69	170415	Nut, Castle 5/16-24
		Bushing .865 X .985 X .790	70	170416	Pin, Cotter 3/32x3/4
2	170352	Kit, Side Housing	71	170417	Brake Spring
		Side Housing, Machined	72	170418	Washer (310-0750)
		Bushing .865 X .985 X .790	73	142884	Washer, Flat
		Bushing .624 X .719 X .562	74	170419	Seal, Oil
3	170353	Kit, Center Section	75	170420	Ass'y Check Plug
		Center Section, Machined	76	170421	Bolt, Stud 5/16-24
		Bushing .707 X .788 X .591	77	170422	Puck, Friction
4	170354	Swashplate, Trunnion Machined	78	142969	Spring
5	169898	Kit, Cylinder Block (10CC)	79	142980	Spacer
		Block - Cylinder	80	150778	Nut, Nylon Insert Hex Lock 5/16-24
		Piston	81	170423	Wedge, Friction
		Spring, Compression	82	170424	Clip, Washer
		Washer Thrust	84	170425	Fitting, 5/16 X Sae 5/32 Tube
6	178322	Sealant Tube	85	170426	Hose, Expansion Tank
7	170356	Hexflange Screw 1/4-20 X 1.25	87	401264	Cap, Barbed Vent
8	170357	Stud, 5/16-24 Hex Double End	88	178334	Bolt, Self Tapping (BDR)
9	170358	Shaft, Input	90	170430	Puck, Inner Wedge
10	170359	Retaining Ring	93	170431	Spring Clip, Housing
11	170360	Spacer	107	170432	Deflector
12	169870	Retaining Ring	108	170433	Washer, Motor Shaft .71id X 1.15OD X .03 Thick
13	170361	Seal, Lip .67 X 1.58 X .276	109	170434	Plug, Straight Thread 9/16-18
14	173158	Bearing, Ball 6203 (BDR)	111	170435	O-ring, .7 X .301 ID
16	170362	Hex Flange Head Screw 1/4-20 X 1.25	113	170437	Bracket, Support Expansion Tank
17	170363	Seal, Lip 18 X 32 X 7	119	191031	Kit, Fan - Washer - Nut
18	170364	Arm, Control			Fan, 7 In
19	173159	Bearing, Thrust (10cc)			Hex Lock Nut 1/2-20 (Nylon Insert)
23	170365	Check Plug Assembly			Washer, Or Slotted, .53 X 1.63 X .06
24	170366	Shaft Motor			Pulley
27	170367	Gear, Pinion, 13T	120	170440	Belt Keeper
28	170368	10T / 48T Gear	123	401265	Kit, Center Section Filter Bypass
29	170369	Gear, 10T Jackshaft	124	170444	Center Section Machining
30	170370	60T Bullgear			Base Filter W/ Poppet
31	170371	Sleeve Bearing .75 X 1.75 X .625			Check Plug Assembly, .027 Washer
32	170389	Sleeve Bearing (Outboard) .75 X 1.575 X .625			Check Plug Assembly, Washer
33	142991	Washer			Spring, Bypass
34	170390	Lip Seal, Axle Shaft			Actuator, Bypass
35	170391	Shaft, Axle (Keyed, R.H.)			Deflector
36	170392	Shaft, Axle (Keyed, L.H.)			Bottom, Filter
37	401260	Miter Gear (Splined)			Bushing, .707 X .788 X .591
38	401261	Miter Gear	125	170445	Kit, Filter
39	150809	Differential Shaft (310-0750)			Bottom, Filter
40	170393	Retaining Ring			Spring, Bypass
41	170394	Pin, Jackshaft			Actuator, Bypass
42	170395	Magnet, Ring			Deflector
43	170396	Spring, Bypass			Base, Filter W/ Poppet
44	150797	Bolt 3/8-24 X 2-1/2	126	170446	Kit, Fan/pulley
45	170397	Filter			Hex Jam 1/20-20 (Nylon Inser)
46	170398	Base, Filter			Washer, OD Slotted, .53 X 1.63 X .06
47	170399	Actuator, Bypass			Fan, 7 In
48	170400	Rod, Bypass Actuator			Pulley
49	196599	Arm, Bypass			Kit, Seal
50	170402	Retaining Ring .25 External	127	170447	Lip Seal .67 X 1.58 X .276
51	170403	Seal, Lip .741 X .25 X .25			Lip Seal 18 X 32 X 7
52	170404	Washer, Flat 0.050" (210-1000)			Lip Seal .706 X 1.584 X .25
53	170405	Retaining Ring			Lip Seal .741 X .250 X .250 TC
54	170406	Bearing, Center Block			Oil Seal .625 X 1.0 X .25
55	142977	Spring, Helical Compression			O-ring .07 X .301 ID
56	142978	Washer, Block Thrust	128	401266	Kit, Expansion Tank
57		20v-50 Oil			Tank, Expansion Assembly
58	142929	Kit, Brake Yoke			Cap, Barbed Vent
59	170408	Rotor, Brake			Bolt, Self Tapping 10-32 X 1/2
60	142883	Brake Puck			Bracket, Support Expansion Tank
61	142882	Brake Puck Plate			Hose, Expansion Tank
62	170409	Pin, Brake Actuating			Transaxle Assembly-Complete
63	170410	Hfncs 1/4-20 X 2 W/patch, Special Flange	900	197942	
64	142892	Bolt, Nylok			
65	170411	Spacer, Brake Torsion Spring			
66	401262	Spring, Brake Arm Bias			

Note: All Component Dimensions Given In U.S.
Inches 1 Inch = 25.4 mm

TRACTOR - - MODEL NUMBER 944.607930

BRIGGS ENGINE - MODEL NUMBER 31P977, TYPE NUMBER 0635-E1

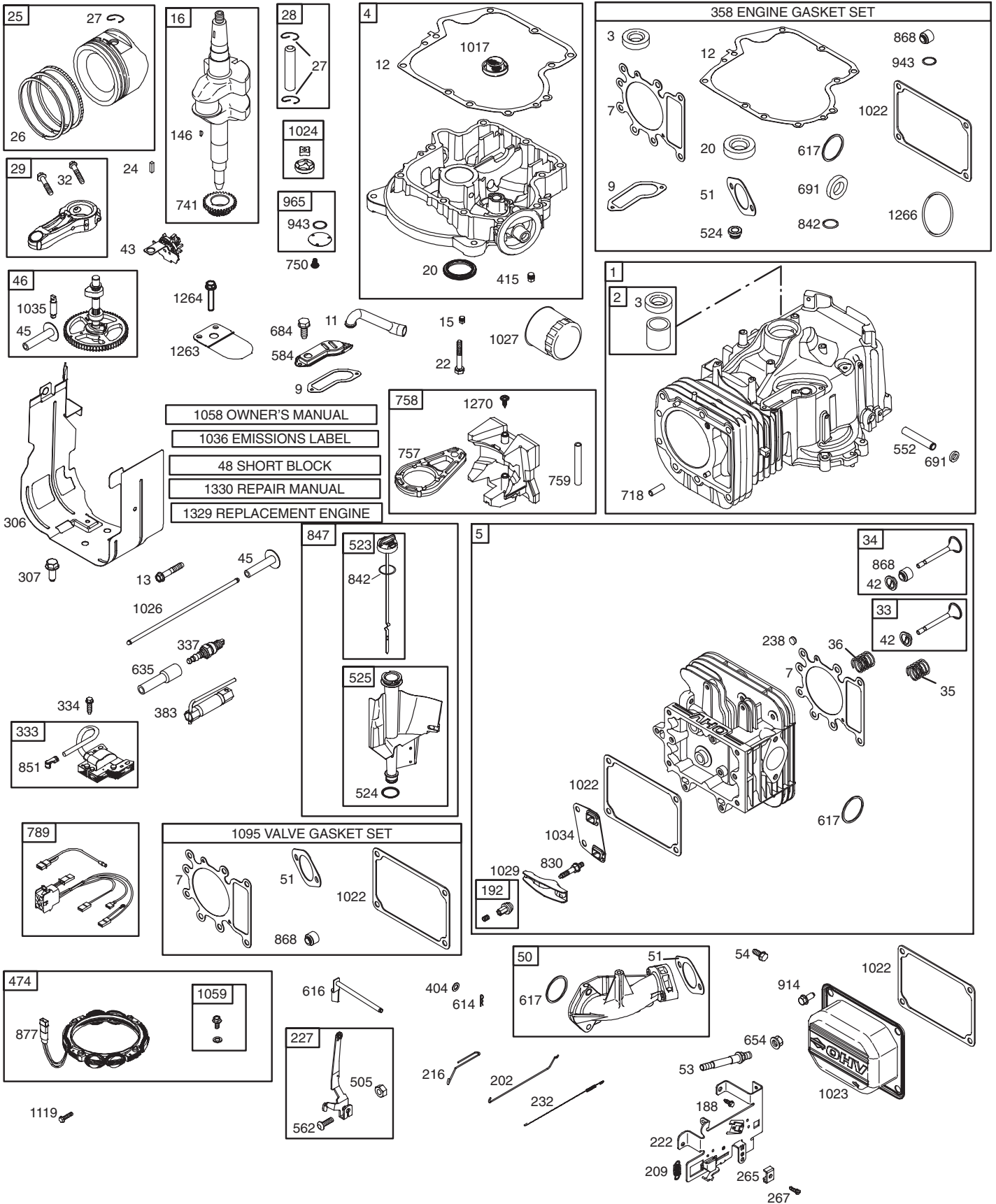

TRACTOR - - MODEL NUMBER 944.607930
BRIGGS ENGINE - MODEL NUMBER 31P977, TYPE NUMBER 0635-E1

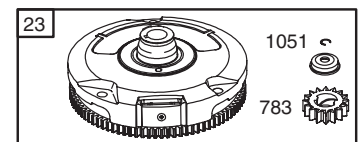
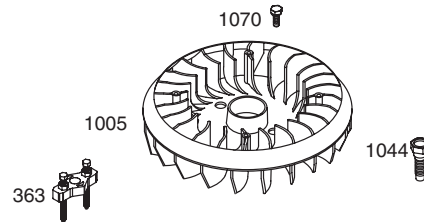
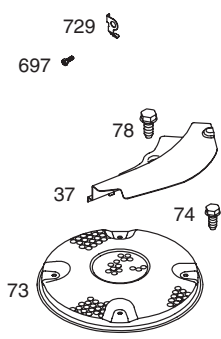
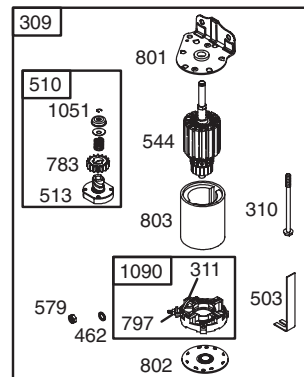
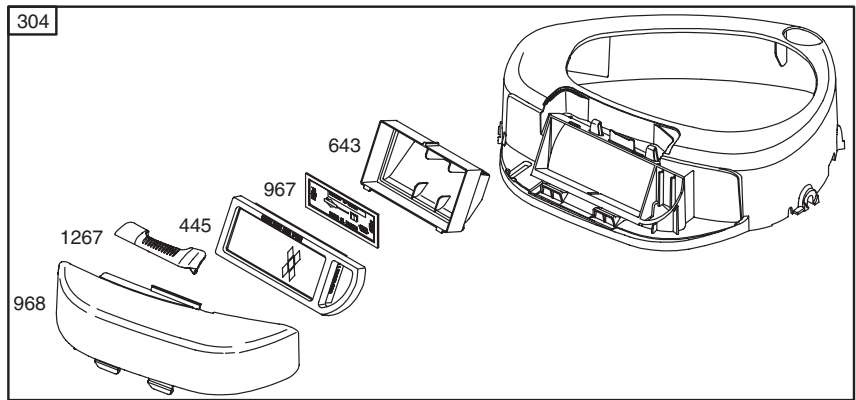
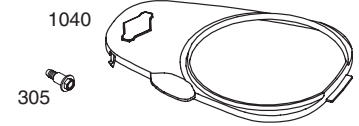
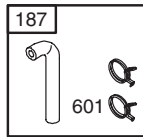
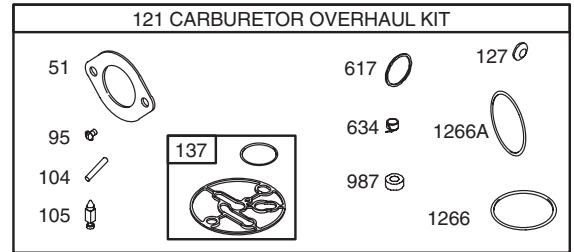
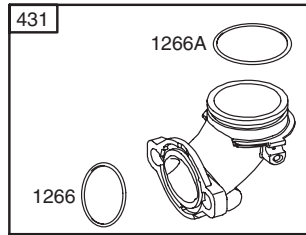
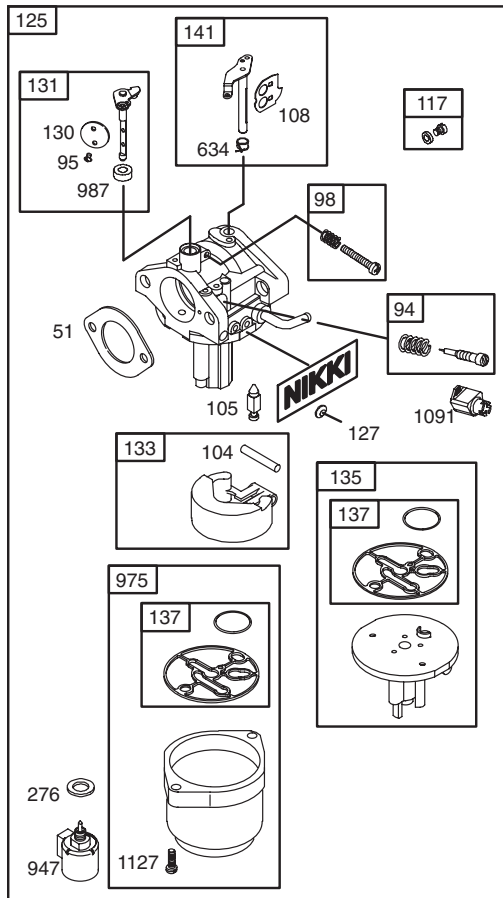

TRACTOR - - MODEL NUMBER 944.607930

BRIGGS ENGINE - MODEL NUMBER 31P977, TYPE NUMBER 0635-E1

KEY NO.	PART NO.	DESCRIPTION	KEY NO.	PART NO.	DESCRIPTION
1	697174	Cylinder Assembly	121	792369	Kit-Carburetor Overhaul
2	399265	Kit-Bushing/Seal (Magneto Side)	125	792768	Carburetor
3	391086s	• Seal-Oil (Magneto Side)	127	690727	Ø Plug-Welch
4	697188	Sump-Engine	130	792747	Valve-Throttle
5	792770	Head-Cylinder	131	792765	Kit-Throttle Shaft
7	699168	•+ Gasket-Cylinder Head	133	694914	Float-Carburetor
9	697109	• Gasket-Breather	135	698780	Tube-Fuel Transfer
11	697113	Tube-Breather	137	698781	Ø Gasket-Float Bowl
12	697110	• Gasket-Crankcase	141	792777	Kit-Choke Shaft
13	690360	Screw (Cylinder Head)	146	691639	Key-Timing
15	690946	Plug-Oil Drain	187	791805	Line-Fuel
16	697127	Crankshaft	188	691693	Screw (Control Bracket)
20	690947	• Seal-Oil (PTO Side)	192	691986	Adjuster-Rocker Arm
22	692125	Screw (Crankcase Cover/Sump)	202	691841	Link-Mechanical Governor
23	693557	Flywheel	209	692208	Spring-Governor
24	222698s	Key-Flywheel	216	691840	Link-Choke
25	791937	Piston Assembly (Standard)	222	694042	Bracket-Control
26	791936	Ring Set (Standard)	227	691374	Lever-Governor Control
27	698469	Lock-Piston Pin	232	691842	Spring-Governor
28	697099	Pin-Piston	238	691843	Cap-Valve
29	791631	Rod-Connecting	240	394358s	Filter-Fuel
32	791118	Screw (Connecting Rod)	265	691024	Clamp-Casing
33	791934	Valve-Exhaust	267	695134	Screw (Casing Clamp)
34	791935	Valve-Intake	276	695410	Ø Washer-Sealing
35	691279	Spring-Valve (Intake)	304	699704	Housing-Blower
36	691279	Spring-Valve (Exhaust)	305	697102	Screw (Blower Housing)
37	697352	Guard-Flywheel	305A	697103	Screw (Blower Housing)
42	499586	Retainer-Valve	306	697107	Shield-Cylinder
43	691968	Slinger-Governor/Oil	307	691003	Screw (Cylinder Shield)
45	690564	Tappet-Valve	309	693551	Motor-Starter
46	791942	Camshaft	310	690323	Bolt (Starter Motor)
48	N/A	Short Block	311	497608	Brush Set
50	690193	Manifold-Intake	333	492341	Armature-Magneto
51	692137	•Ø+ Gasket-Intake	334	691061	Screw (Magneto Armature)
53	690227	Stud (Carburetor)	337	491055s	Plug-Spark
54	691148	Screw (Intake Manifold)	358	697191	Gasket Set-Engine
73	697133	Screen-Rotating	363	19203	Flywheel Puller
74	697897	Screw (Rotating Screen)	383	89838s	Wrench-Spark Plug
78	691003	Screw (Flywheel Guard)	404	691691	Washer (Governor Crank)
94	695425	Kit-Idle Mixture	415	690283	Plug
95	690718	Ø Screw (Throttle Valve)	431	697122	Elbow-Intake
98	695408	Kit-Idle Speed	445	697153	Filter-Air Cleaner Cartridge
104	694918	Ø Pin-Float Hinge	462	691261	Washer (Starter Cable)
105	696136	Ø Valve-Float Needle	474	696459	Alternator
108	695419	Valve-Choke	503	691532	Strap-Starter
117	792296	Jet-Main (Standard)	505	691251	Nut (Governor Control Lever)
			510	693699	Drive-Starter
			513	692024	Clutch-Drive

TRACTOR - - MODEL NUMBER 944.607930

BRIGGS ENGINE - MODEL NUMBER 31P977, TYPE NUMBER 0635-E1

KEY NO.	PART NO.	DESCRIPTION	KEY NO.	PART NO.	DESCRIPTION
523	699908	Dipstick	965	499613	Cover-Oil Pump
524	691032	• Seal-Dipstick Tube	967	697015	Filter-Pre Cleaner
525	697184	Tube-Dipstick	968	698403	Cover-Air Cleaner
544	692034	Starter-Armature	975	699502	Bowl-Float
552	697144	Bushing-Governor Crank	987	698777	∅ Seal-Throttle Shaft
562	691119	Bolt (Governor Control Lever)	1005	699043	Fan-Flywheel
579	691029	Nut (Starter Cable)	1017	690770	Screen-Oil Pump
584	697112	Cover-Breather Passage	1022	272475s	•+ Gasket-Rocker Cover
601	791850	Clamp-Hose	1023	791079	Cover-Rocker Arm
614	691620	Pin-Cotter	1024	499054	Pump-Oil
616	692012	Crank-Governor	1026	692003	Rod-Push (Intake)
617	692138	∅ • Seal-O Ring (Intake Manifold)	-- --	692011	Rod-Push (Exhaust)
634	698779	∅ Spring/Seal Assembly (Choke A Matic)	1027	696854	Filter-Oil
635	691909	Boot-Spark Plug	1029	691751	Arm-Rocker
643	698401	Retainer-Air Filter	1034	690822	Guide-Push Rod
654	690958	Nut (Carburetor)	1035	693784	Shaft-Pump
684	697157	Screw (Breather Passage Cover)	1036	791932	Label-Emissions
691	692407	• Seal-Governor Shaft	1040	699852	Plate-Trim
697	690372	Screw (Drive Cap)	1044	698139	Screw (Flywheel)
718	690959	Pin-Locating	1051	691265	Ring-Retaining
729	691224	Clip-Wire	1058	275935	Owner's Manual
741	697128	Gear-Timing	1059	698516	Kit-Screw/Washer
750	790832	Screw (Oil Pump Cover)	1070	690372	Screw (Flywheel Fan)
757	697607	Link-Counterweight	1090	691293	Retainer-Brush
758	697134	Counterweight	1091	691333	Cap-Limiter
759	697392	Pin-Counterweight	1095	690190	Gasket Set-Valve
783	693713	Gear-Pinion	1119	691183	Screw (Alternator)
789	698329	Harness-Wiring	1127	695407	Screw (Float Bowl)
797	693167	Nut (Brush Retainer)	1263	697124	Reed-Breather
801	691283	Cap-Drive	1264	697104	Screw (Breather Reed)
802	691286	Cap-End	1266	691917	•∅ Seal-O Ring (Intake Elbow)
803	-- --	Housing-Starter (For service order complete starter motor reference 309)	1266A	697123	∅ Seal-O Ring (Intake Elbow)
830	691095	Stud (Rocker Arm)	1267	697419	Latch-Blower Housing
842	691031	• Seal-O Ring (Dipstick Tube)	1270	697156	Plug-AVS Counterweight
847	790442	Dipstick/Tube Assembly	1329	31P977-0036	Replacement Engine (Transfer Muffler and/or Spark Arrester Assembly from the original engine if suitable for additional service or add new parts as required)
851	692424	Terminal-Spark Plug			
868	690968	•+ Seal-Valve	1330	272147	Repair Manual
877	393456	Wire/Connector-Alternator			
914	691108	Screw (Rocker Cover)	•		Included in Engine Gasket Set, Key. No. 358
943	690589	• Seal-O Ring (Oil Pump Cover)	∅		Included in Carburetor Overhaul Kit, Key. No. 121
947	699915	Solenoid-Fuel	+		Included in Valve Gasket Set, Key. No. 1095

NOTE: All component dimensions given in U.S. inches
1 inch = 25.4 mm

SERVICE NOTES

SUGGESTED GUIDE FOR SIGHTING SLOPES FOR SAFE OPERATION

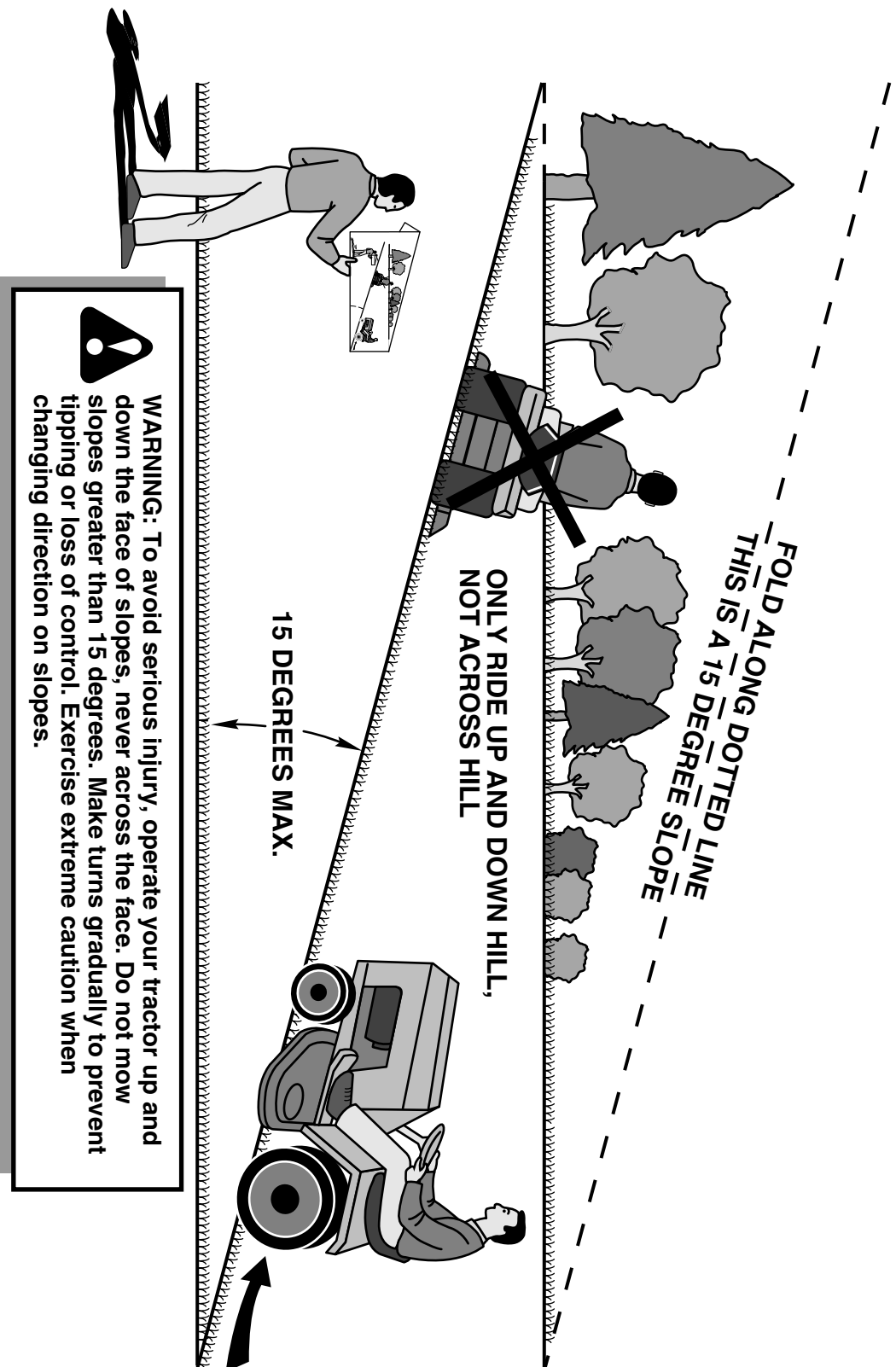

Get it fixed, at your home or ours!

Just Call:

1-800-4-MY-HOME[®]

(1-800-469-4663)

24 hours a day, 7 days a week

For the repair of major brand appliances **in your own home...**
no matter who made it, no matter who sold it!

For your nearest **Sears Parts and Service** location,
to bring in products like vacuums, lawn equipment and electronics.

For **Sears Parts & Service**, to order the replacement parts,
accessories and owner's manuals that you need to do-it-yourself.

www.sears.ca

To purchase or inquire about a Sears Maintenance Agreement, call:

1-800-361-6665

9 a.m. – 11 p.m. Mon. – Fri., EST, 9 a.m. – 4 p.m. Sat.

Pour service en français:

1-800-LE-FOYER^{MC}

(1-800-533-6937)

www.sears.ca



® / TM Trademarks of Sears, Roebuck and Co. used under license by Sears Canada

MD Marque déposée / MC Marque de commerce de Sears, Roebuck and Co. utilisée en vertu d'une licence de Sears Canada