

WEED EATER®

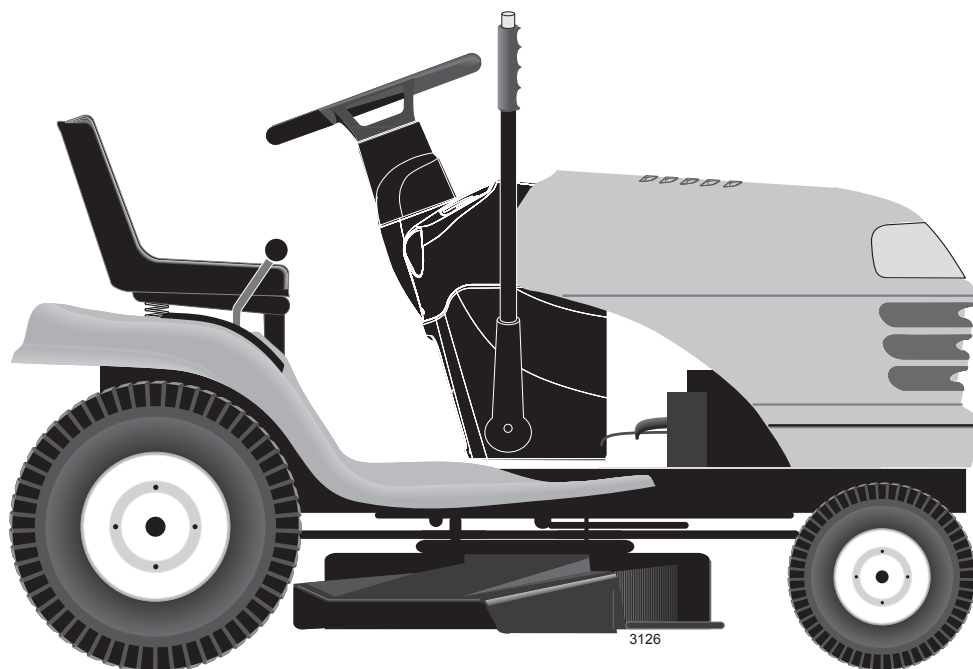

REPAIR PARTS MANUAL

MODEL:

609140

LAWN TRACTOR

ALWAYS WEAR EYE PROTECTION DURING OPERATION

Visit our website: www.weedeater.com



WARNING:

Read this Manual and follow all Warnings and Safety Instructions. Failure to do so can result in serious injury.

HOW TO USE THIS MANUAL

This manual is designed to provide the customer with a means to identify the parts on his/her tractor when ordering repair parts. The illustrations may or may not represent the actual assemblies; therefore, it is not recommended to use this manual as a guide to assemble or disassemble the tractor. Some hardware and parts are drawn larger in order to more readily identify them.

Each tractor has its own model number.

The model number for your tractor can be found on the fender under the seat.

When ordering parts, always give the following information:

- Product - "Lawn Tractor"
- MODEL NUMBER - **609140**
- Part Number
- Part Description

TABLE OF CONTENTS

SCHEMATIC	3
ELECTRICAL.....	4-5
CHASSIS	6-7
DRIVE.....	8-9
STEERING	10-11
ENGINE.....	12-13
MOWER DECK	14-15
MOWER LIFT	16
SEAT	17
DECALS.....	18

TRACTOR - - MODEL NUMBER 609140

SCHEMATIC
SCH03

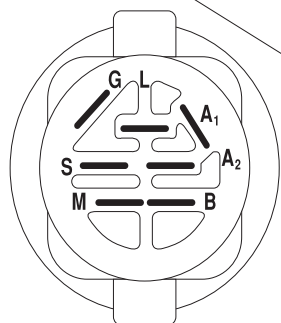
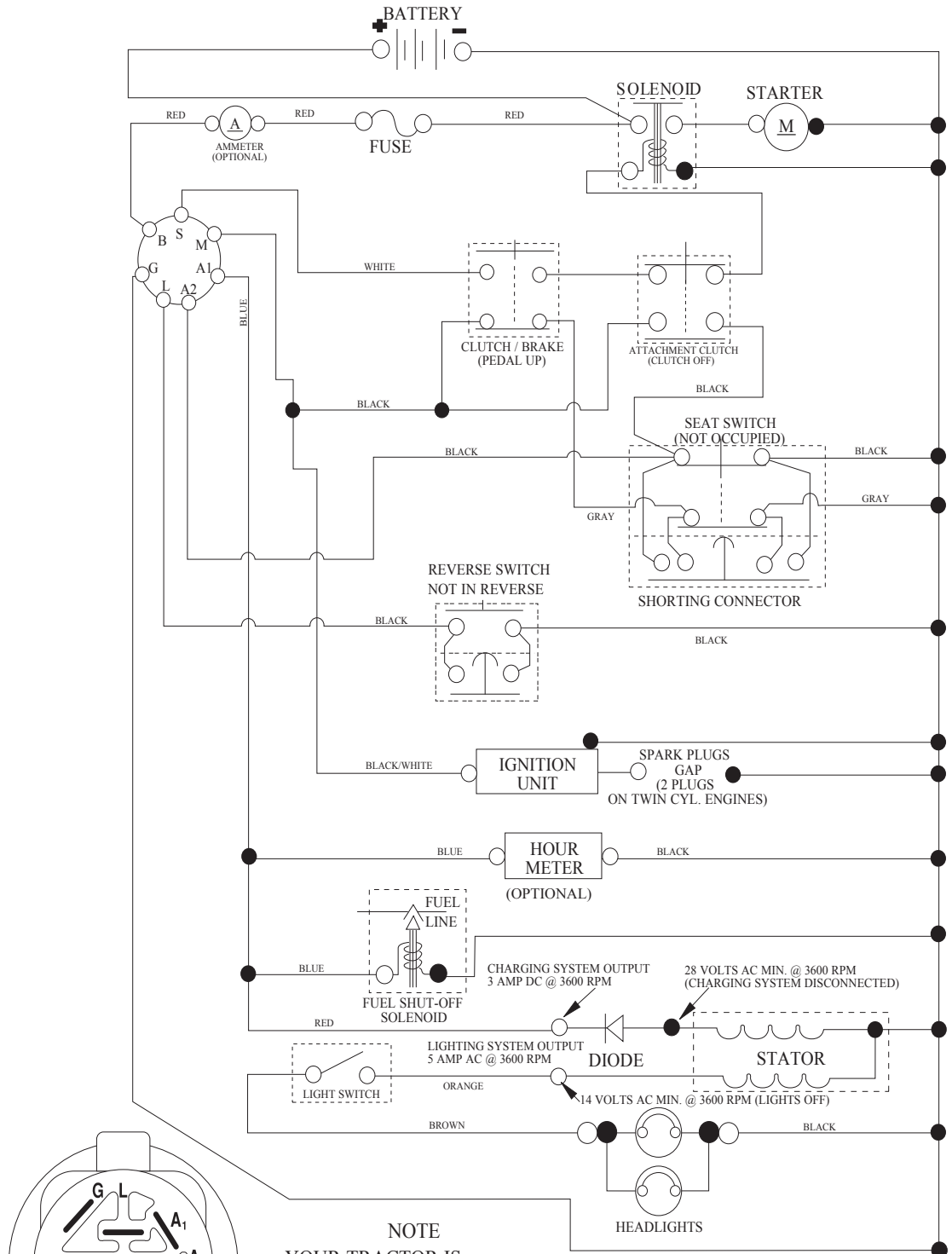

IGNITION SWITCH

POSITION	CIRCUIT	"MAKE"
OFF	M+G+A1	
RUN/OVERRIDE	B+A1	
RUN	B+A1	L+A2
START	B + S + A1	

NOTE

YOUR TRACTOR IS EQUIPPED WITH A SPECIAL ALTERNATOR SYSTEM. THE LIGHTS ARE NOT CONNECTED TO THE BATTERY, BUT HAVE THEIR OWN ELECTRICAL SOURCE. BECAUSE OF THIS, THE BRIGHTNESS OF THE LIGHTS WILL CHANGE WITH ENGINE SPEED. AT IDLE THE LIGHTS WILL DIM. AS THE ENGINE IS SPEEDED UP, THE LIGHTS WILL BECOME THEIR BRIGHTEST.



WIRING INSULATED CLIPS
NOTE: IF WIRING INSULATED CLIPS WERE REMOVED FOR SERVICING OF UNIT, THEY SHOULD BE RE-INSTALLED TO PROPERLY SECURE YOUR WIRING.

TRACTOR - - MODEL NUMBER 609140

ELECTRICAL

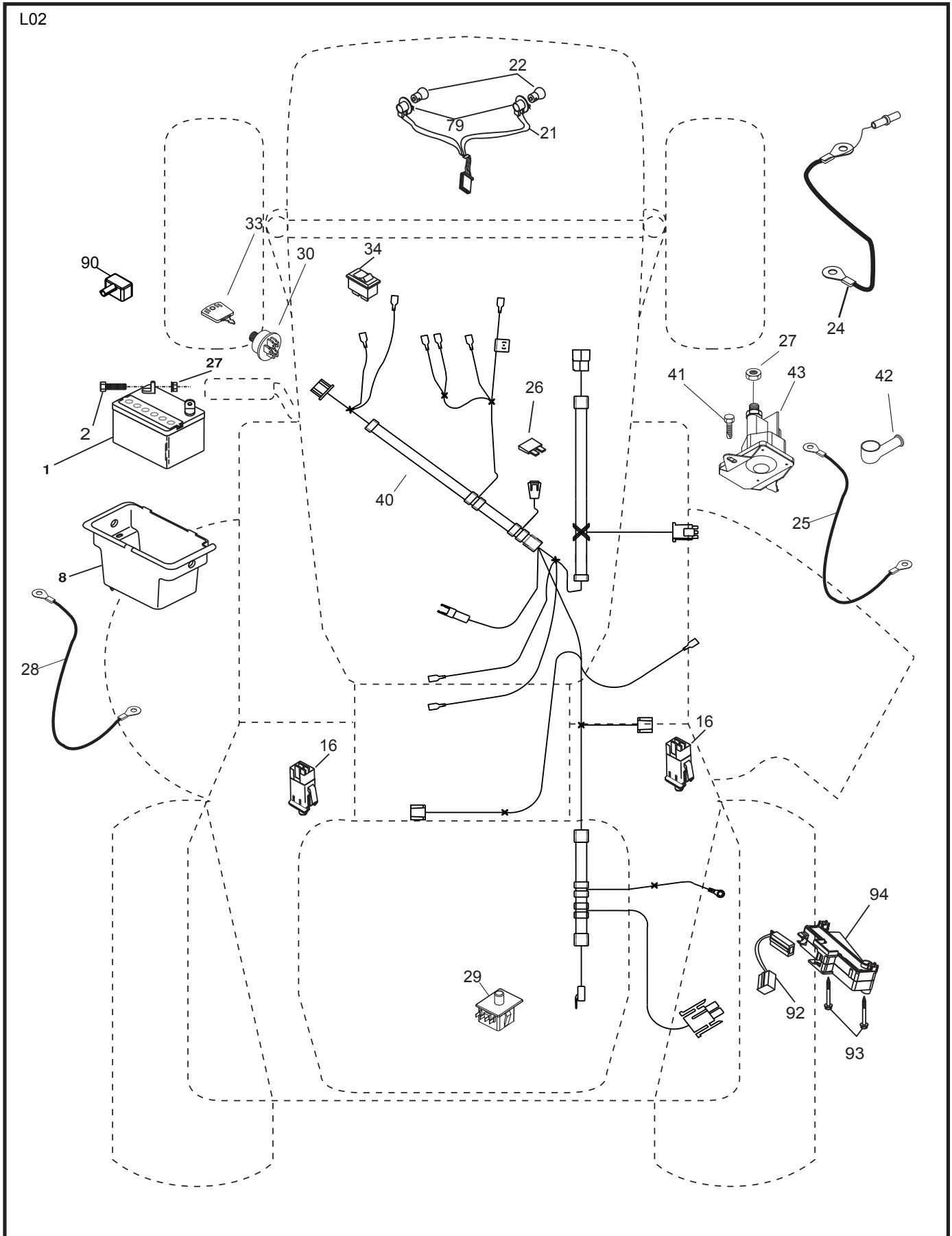

TRACTOR - - MODEL NUMBER 609140

ELECTRICAL

KEY NO.	PART NO.	DESCRIPTION
1	163465	Battery
2	74760412	Bolt Hex Hd 1/4-20 unc x 3/4
8	176689	Box Battery
16	176138	Switch Interlock
21	175688	Harness Asm Light w/4152J
22	4152J	Bulb Light #1156
24	421299	Cable Battery 6 Ga. 11" Red
25	421297	Cable Battery
26	175158	Fuse 20 AMP
27	73510400	Nut Keps Hex 1/4-20 unc
28	421298	Cable Ground 6 Ga. 12" Black
29	192749	Switch Seat
30	193350	Switch Ign
33	411935	Key/Chain
34	110712X	Switch Light/Reset
40	197428	Harness Ign
41	71110408	Bolt Blk Fin Hex 1/4-20
42	131563	Cover Terminal Red
43	192507	Solenoid
79	175242	Socket Asm. Bulb
90	180449	Cover Terminal Battery
92	196615	Harness Pigtail
93	192540	Screw Plastite 10-14 x 2.0
94	191834	Module Reverse

NOTE: All component dimensions given in U. S. inches
1 inch = 25.4 mm.

TRACTOR - - MODEL NUMBER 609140

CHASSIS

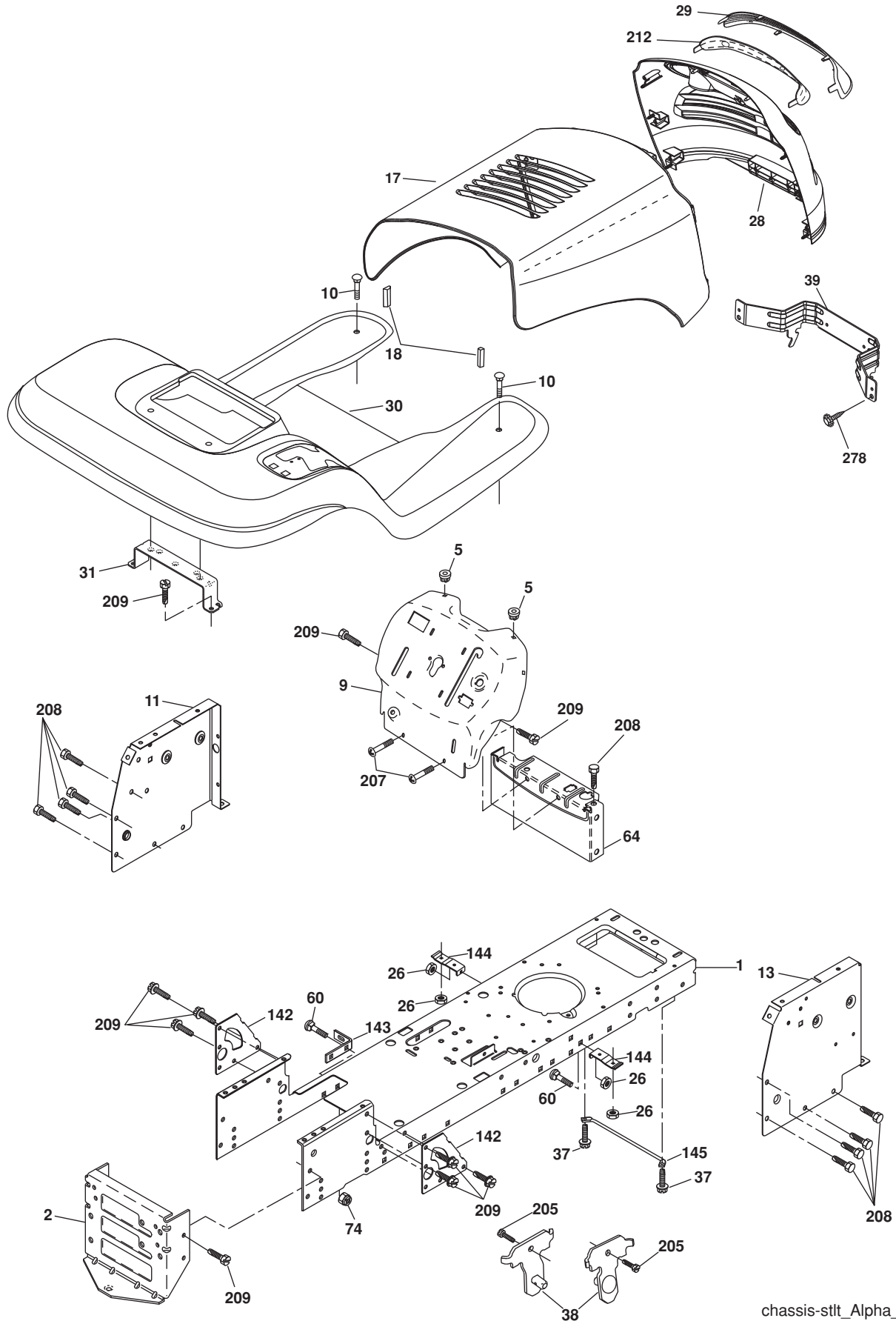

chassis-stlt_Alpha_7_r1

TRACTOR - - MODEL NUMBER 609140

CHASSIS

KEY NO.	PART NO.	DESCRIPTION
1	174619	Chassis
2	176554	Drawbar, Stretch
5	155272	Bumper, Hood/Dash
9	193510X010	Dash
10	72140608	Bolt, Carriage 3/8-16 x 1
11	174996	Panel Dash LH
13	172105X010	Panel Silkscr Dash RH
17	187559X550	Hood
18	184921	Bumper Hood
26	73800600	Nut Lock Hex w/Ins 3/8-16 unc
28	187565X428	Grille
29	187567X599	Lens Grille Basic Bar
30	192394X550	Fender
31	139976	Bracket Fender Repl 109873X
37	17490508	Screw Thdrol 5/16-18 x 1/2 TYT
38	175710	Bracket Asm. Pivot Mower
39	187568	Bracket Pivot
60	72140606	Bolt Carr 3/8-16 x 3/4
64	154798	Dash Lower
74	73680600	Nut 3/8-16 Center Lock
142	175702	Plate Reinforcement
143	186689	Bracket Swaybar Chassis
144	175582	Bracket Footrest
145	409167	Rod Pivot Hood
205	17490608	Screw Thdrol 3/8-16 x 1/2
207	17670508	Screw Thdrol 5/16-18 x 1/2
208	17670608	Screw Thdrol 3/8-16 x 1/2
209	17000612	Screw Hex Wsh Thdrol 3/8-16
212	187569	Insert Lens Reflect
278	416358	Screw #10 x 0.750
--	5479J	Plug Button Blk 359 Dia Choke
--	187801	Plug Dome Plastic

NOTE: All component dimensions given in U.S. inches
1 inch = 25.4 mm.

TRACTOR - - MODEL NUMBER 609140

DRIVE

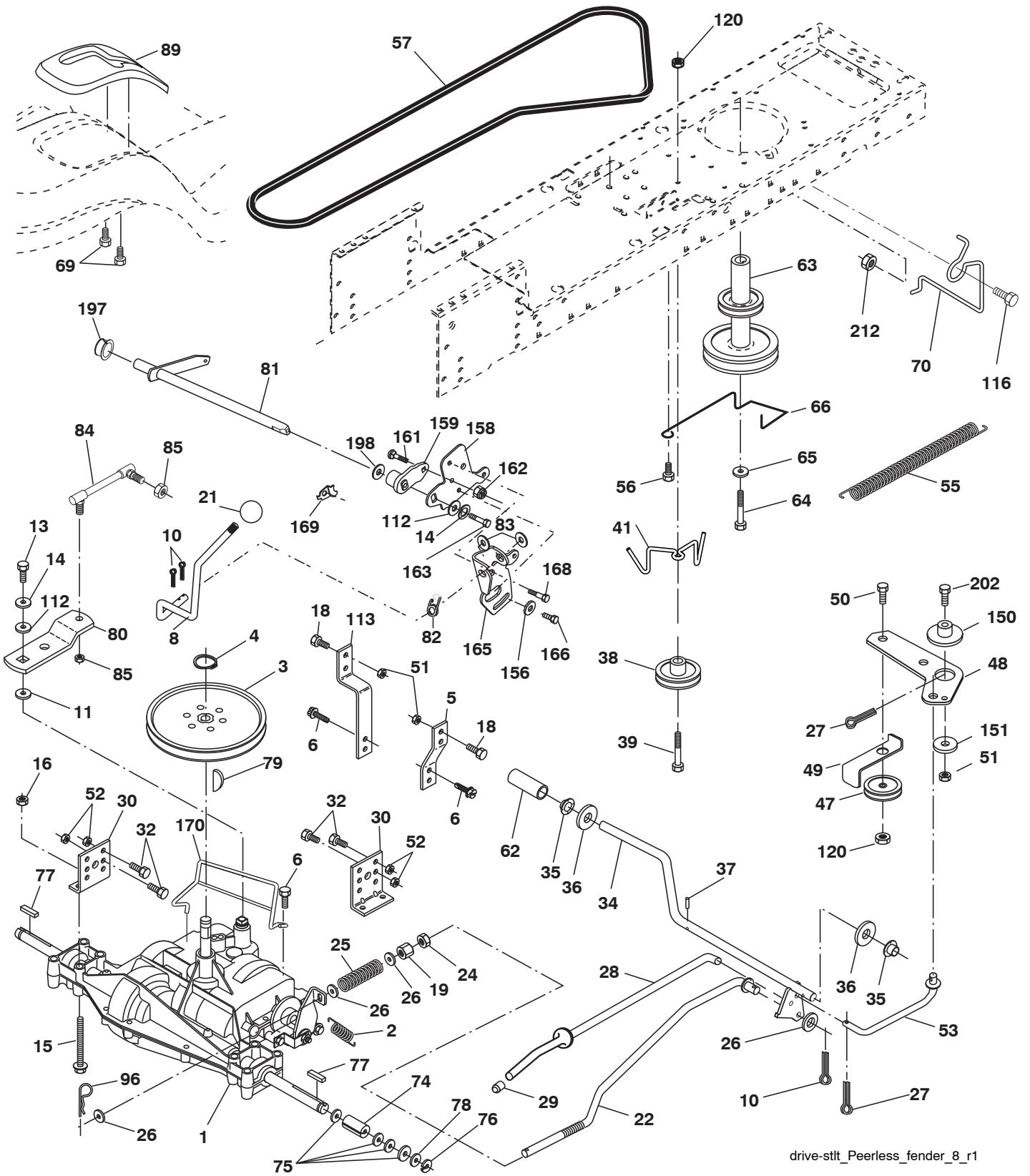

drive-sttt_Peerless_fender_8_r1

TRACTOR - - MODEL NUMBER 609140

DRIVE

KEY NO.	PART NO.	DESCRIPTION	KEY NO.	PART NO.	DESCRIPTION
1	-----	Transaxle Peerless 205-544C (Order parts from transaxle manufacturer)	64	173937	Bolt Hex
2	146682	Spring Return Brake T/a Zinc	65	10040700	Washer Lock Hvy Hlcl Spr 7/16
3	123666X	Pulley Transaxle 18" Tires	66	154778	Keeper Belt Engine Foolproof
4	1200028	Ring Retainer # 5100-62	69	142432	Screw Hex Wsh HiLo 1/4 x 1/2 unc
5	121520X	Strap Torque 30 Degrees	70	134683	Guide Belt Mower Drive RH
6	17060512	Screw 5/16-18 x 3/4	74	137057	Spacer Axle
8	192502	Rod Shift Fender Adjust Lt	75	121749X	Washer 25/32 x 1 1/4 x 16 Ga.
10	76020416	Pin Cotter 1/8 x 1 Cad	76	12000001	E-ring #5133-75
11	105701X	Washer Plate Shf 388 Sq Hole	77	123583X	Key Square 2 0 x 1845/ 1865
13	74550412	Bolt 1/4-28 unF Gr. 8 w/Patch	78	121748X	Washer 25/32 x 1-5/8 x 16 Ga.
14	10040400	Washer Lock Hvy Helical	79	2228M	Key Woodruff #9 3/16 x 3/4
15	74490544	Bolt Hex FLGHD 5/16-18 Gr. 5	80	131486	Arm Shift
16	73800500	Nut Lock Hex w/Ins 5/16-18	81	165594	Shaft Asm Cross Tapered PMST/20
18	74780616	Bolt, Fin Hex 3/8-16 unc x 1 Gr. 5	82	165711	Spring Torsion T/a
19	73800600	Nut Lock 3/8-16 unc	83	19171216	Washer 17/32 x 3/4 x 16 Ga.
21	106933X	Knob	84	166228	Link Transaxle Dana/18" Zinc
22	130804	Rod Brake Blk Zinc 26 840	85	150360	Nut Lock Center 1/4 - 28 FNTHD
24	73350600	Nut Hex Jam 3/8-16 unc	89	192389X428	Console Shift STLT
25	106888X	Spring Rod Brake 2 00 Zinc	96	4497H	Retainer Spring 1"
26	19131316	Washer 13/32 x 13/16 x 16 Ga.	112	19091210	Washer 9/32 x 3/4 x 10 Ga.
27	76020412	Pin Cotter 1/8 x 3/4 Cad	113	127285X	Strap Torque LT
28	175765	Rod Brake Parking LT/YT	116	72140608	Bolt Rdhd Sq Neck 3/8-16 x 1
29	71673	Cap Brake Parking	120	73900600	Nut Lock Flg. 3/8-16 unc
30	174973	Bracket Mtg Transaxle	150	175456	Spacer Retainer
32	74760512	Bolt Hex Hd 5/16-18 unc x 3/4	151	19133210	Washer 13/32 x 2 x 10
34	175578	Shaft Asm Pedal Foot	156	166002	Washer Srrted 5/16ID x 1.125
35	120183X	Bearing Nylon Blk 629 Id	158	165589	Bracket Shift Mount
36	19211616	Washer 21/32 x 1 x 16 Ga.	159	183900	Hub Tapered Flange Shift Lt
37	1572H	Pin Roll 3/16 x 1"	161	72140406	Bolt Rdhd Sqnk 1/4-20 x 3/4
38	179114	Pulley Composite Flat	162	73680400	Nut Crownlock 1/4-20 unc
39	72110622	Bolt RDHD 3/8-16 unc x 2-3/4 Gr. 5	163	74780416	Bolt Hex Fin 1/4-20 unc x 1 Gr. 5
41	175556	Keeper Belt Flat Idler	165	165623	Bracket Pivot Lever
47	127783	Pulley Idler V Groove Plastic	166	17490510	Screw 5/16-18 x 5/8
48	154407	Bellcrank Asm	168	165492	Bolt Shoulder 5/16-18 x .561
49	123205X	Retainer Belt Style Spring	169	165580	Plate Fastening
50	72110612	Bolt Carr. Sh. 3/8-16 x 1-1/2 Gr. 5	170	187414	Keeper Belt Transaxle Gear
51	73680600	Nut Crownlock 3/8-16 unc	197	169613	Nyliner Snap-In
52	73680500	Nut Crownlock 5/16-18 unc	198	169593	Washer Nyliner
53	199652	Link Clutch	202	72110614	Bolt RdHd 3/8-16 unc x 1-3/4 Gr. 5
55	105709X	Spring Return Clutch 6 75	212	145212	Nut Hexflange Lock
56	17060620	Screw 3/8-16 x 1-1/4			
57	138255	V-Belt Ground Drive			
62	8883R	Cover Pedal Blk Round			
63	175410	Engine Pulley			

NOTE: All component dimensions given in U.S. inches
1 inch = 25.4 mm

TRACTOR - - MODEL NUMBER 609140

STEERING

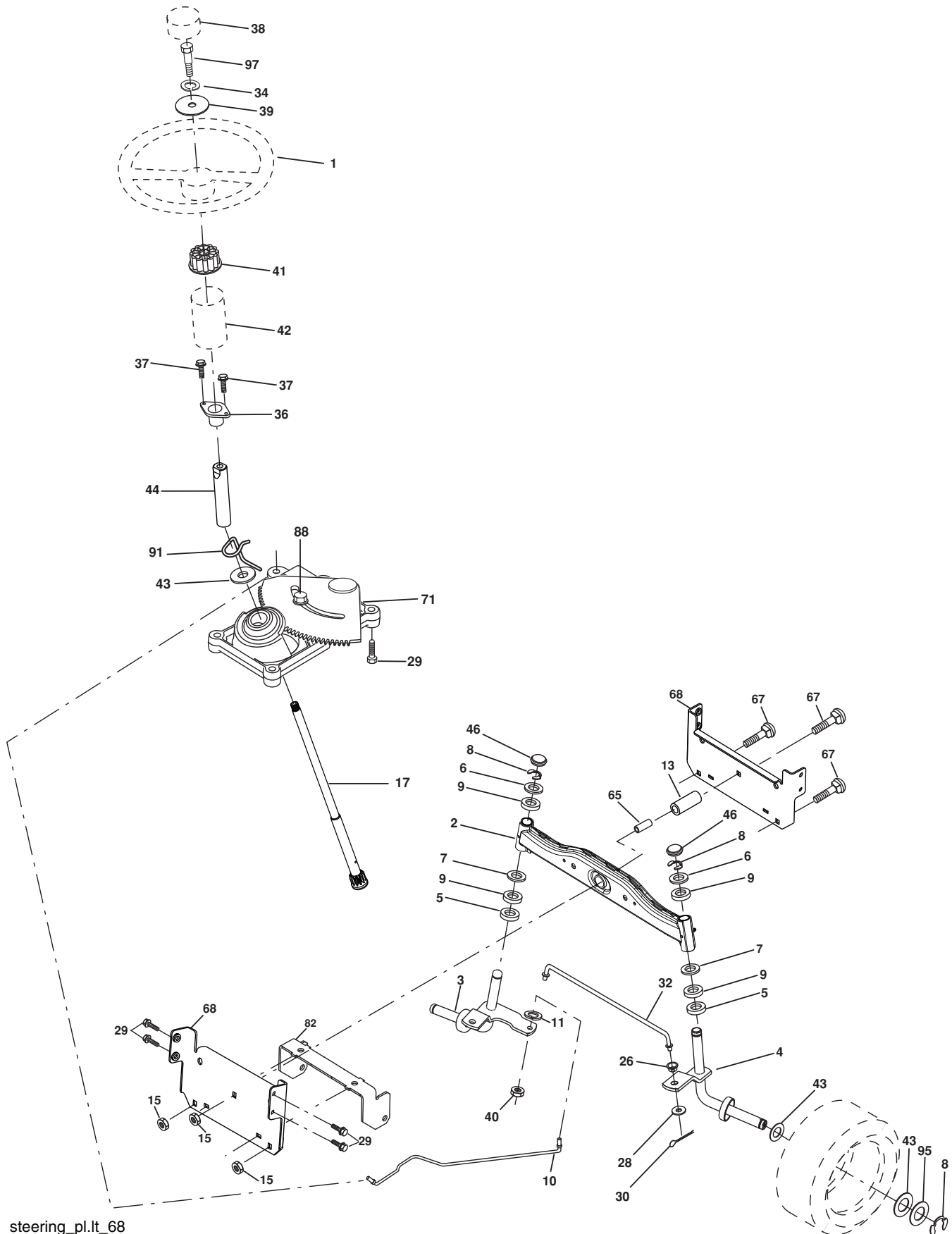

steering_pl.it_68

TRACTOR - - MODEL NUMBER 609140

STEERING

KEY NO.	PART NO.	DESCRIPTION
1	186780	Wheel Steering
2	418168	Axle Asm
3	169840	Spindle Asm LH
4	169839	Spindle Asm RH
5	6266H	Bearing Race Thrust Harden
6	121748X	Washer 25/32 x 1-5/8 x 16 Ga.
7	19272016	Washer 27/32 x 1-1/4 x 16 Ga.
8	12000029	Ring Clip #t5304-75
9	3366R	Bearing Col Strg Blk
10	175121	Link Drag
11	10040600	Washer Lock Hvy Hlcl Spr 3/8
13	136518	Spacer Bearing Axle Front
15	145212	Hexflange Lock
17	411386	Shaft Asm Strg
26	126847X	Bushing Link Drag Blk LR
28	19131416	Washer 13/32 x 7/8 x 16 Ga.
29	17000612	Screw 3/8-16 x 3/4
30	76020412	Pin Cotter 1/8 x 3/4 Cad
32	192757	Rod Tie Wire Form 19 75 Mech
34	10040500	Washer Lock Hvy Hlcl Spr 5/16
36	155099	Bushing Strg 5/8 Id Dash
37	152927	Screw
38	192916	Cap Wheel Steer Ayp
39	19113812	Washer 11/32 ID x 2-3/8 OD x 12 Ga.
40	73540600	Nut Crownlock 3/8-24
41	186737	Adapter Wheel Strg
42	145054X428	Boot Dash Mtl Steering Blk
43	121749X	Washer 25/32 x 1 1/4 x 16 Ga.
44	190752	Extension Steering
46	121232X	Cap Spindle Fr Top Blk
65	414736	Spacer Brace Axle
67	72110618	Bolt RDHD SQNK 3/8-16 x 2-1/4
68	169827	Brace Axle
71	175146	Steering Asm.
82	199978	Bracket Susp Chassis Front
88	175118	Bolt Shoulder 7/16-20
91	175553	Clip Steering
95	188967	Washer Harden .793 x 1.637 x 060
97	74780564	Bolt 5/16-18 unc x 4"L Hlcl Spr. 5/16

NOTE: All component dimensions given in U.S. inches
1 inch = 25.4 mm.

TRACTOR - - MODEL NUMBER 609140

ENGINE

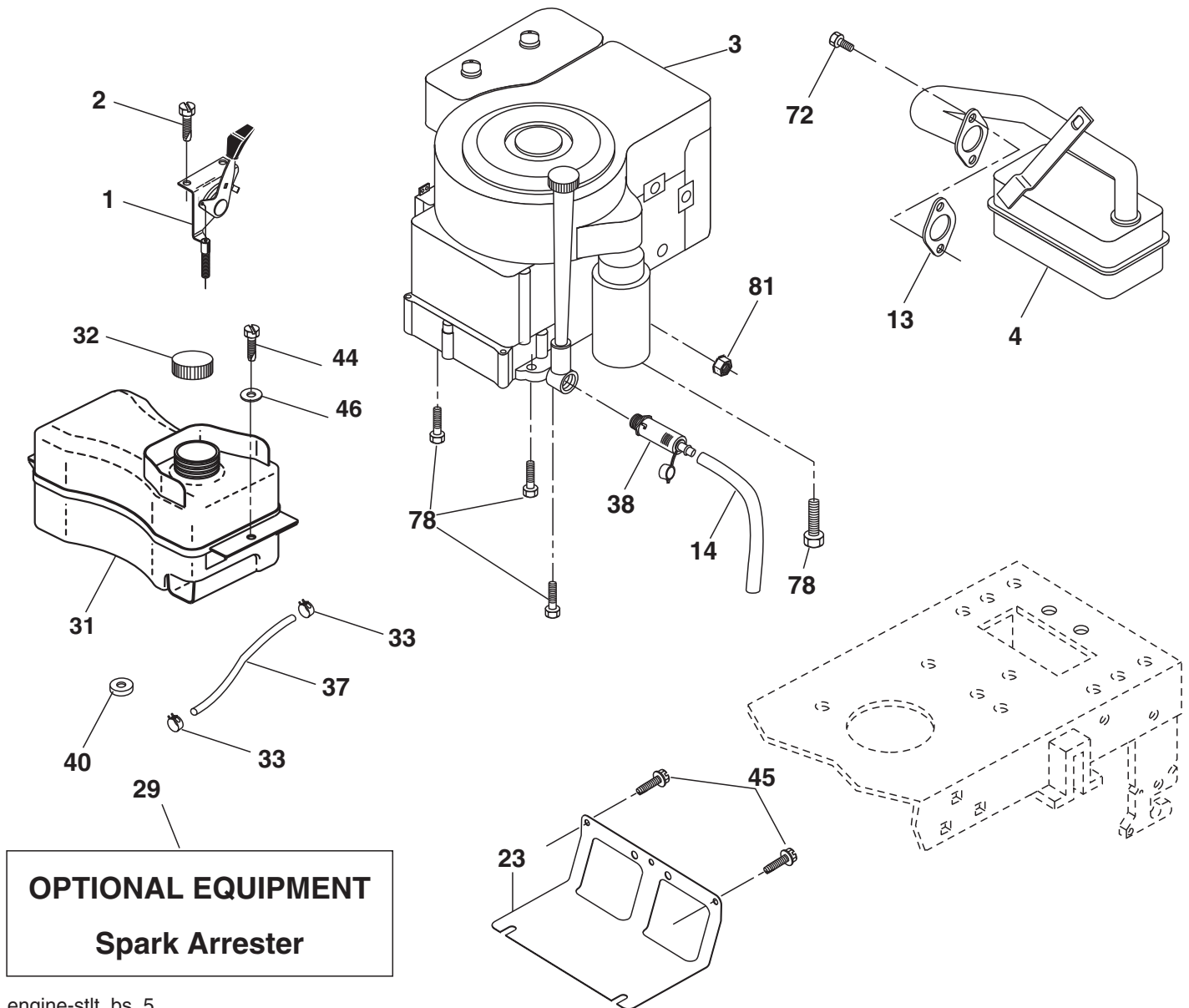

engine-stlt_bs_5

TRACTOR - - MODEL NUMBER 609140

ENGINE

KEY NO.	PART NO.	DESCRIPTION
1	170551	Control Th/ch Flag
2	17720408	Screw Hex Thd Cut 1/4-20 x 1/2
3	-----	Engine, B&S 21B807 (Order parts from engine manufacturer)
4	179758	Muffler Exhaust B&S
13	165291	Gasket Eng 1 313 Id Tin Plated
14	148456	Tube Drain Oil Easy
23	169837	Shield BRN/DBR Guard
29	137180	Kit Spark Arrestor (Flat Scrn)
31	407516	Tank Fuel Front
32	425162	Cap Asm Fuel
33	123487X	Clamp Hose
37	137040	Line Fuel
38	181654	Plug Drain Oil
40	124028X	Bushing Snap Nyl Blk Fuel Line
44	17670412	Screw Thdrol 1/4-20 x 3/4
45	17000612	Screw Hex Wsh Thdrol 3/8-16
46	19091416	Washer 9/32 x 7/8 x 16 Ga.
72	192334	Screw Socket Hd 5/16-18 x .75
78	17060620	Screw 3/8-16 x 1-1/4
81	73510400	Nut Keps Hex 1/4-20 unc

NOTE: All component dimensions given in U.S. inches
1 inch = 25.4 mm

For engine service and replacement parts, call the toll free number for your engine manufacturer listed below:

Briggs & Stratton 1-800-233-3723

Engine Power Rating Information

The gross power rating for individual gas engine models is labeled in accordance with SAE (Society of Automotive Engineers) code J11940 (Small Engine Power & Torque Rating Procedure), and rating performance has been obtained and corrected in accordance with SAE J1995 (Revision 2002-5). Actual gross engine power will be lower and is affected by, among other things, ambient operating conditions and engine-to-engine variability. Given both the wide array of products on which engines are placed and the variety of environmental issues applicable to operating the equipment, the gas engine will not develop the rated gross power when used in a given piece of power equipment (actual "on-site" or net horsepower). This difference is due to a variety of factors including, but not limited to, accessories (air cleaner, exhaust, charging, cooling, carburetor, fuel pump, etc.), application limitations, ambient operating conditions (temperature, humidity, altitude), and engine-to-engine variability. Due to manufacturing and capacity limitations, Briggs & Stratton may substitute an engine of higher rated power for this Series engine.

TRACTOR - - MODEL NUMBER 609140

MOWER DECK

KEY NO.	PART NO.	DESCRIPTION	KEY NO.	PART NO.	DESCRIPTION
1	192556	Mower Housing Assembly	72	193216	Spring Brake Return
2	72140506	Bolt Carriage 5/16-18 x 3/4	89	19131311	Washer 13/32 x 13/16 x 11 Ga.
3	138017	Bracket Asm Fr. Sway Bar	92	73800600	Nut Lock 3/8-16
4	192568	Bracket Deck Sway Bar 38"/42"	107	133502	Spacer Retainer
5	4939M	Retainer Spring	108	133503	Stiffener, Idler Arm
6	178024	Bar Sway Deck	122	410190	Link, Brake LH
7	73800500	Nut Lock Hex w/Insert 5/16-18 unc	123	410189	Link, Brake RH
8	193003	Bolt 3/8-24 x 1.25 Gr. 8	129	19131312	Washer 3/8
11	193957	Blade Mower	130	74780616	Bolt Hex 3/8-16 x 1 Gr. 5
13	192872	Shaft Assembly, Mandrel, Vented (Includes Key Number 6)	131	72140608	Bolt Carr 3/8-16 x 1
14	187281	Housing, Mandrel, Vented	144	193414	Keeper Belt Idler Tension
15	110485X	Bearing, Ball, Mandrel	148	169022	Spring Return Idler
18	72140505	Blade Rdhd Sqnk 5/16-18 x 5/8	149	165898	Retainer Spring Yellow
19	132827	Bolt, Shoulder	150	19091210	Washer 9/32 x 3/4 x 10 Ga.
20	400095	Baffle Vortex Front	152	193235	Clutch Cable 38"
21	73680500	Nut	158	17720408	Screw Hex Thd Cut 1/4-20 x 1/2
23	192557	Bracket, Mower Deflector	185	188234	Head Asm Cable Clutch
24	105304X	Cap, Sleeve	186	17490644	Screw Hex Wsh Thdrol 3/8-16 x 2-3/4
25	197026	Spring, Torsion, Deflector	187	193412	Keeper Belt M Shape
26	110452X	Nut, Push	188	165891	Bolt Carriage Idler
27	192572X428	Shield, Deflector	189	192559	Brake Stand
29	131491	Rod, Hinge	190	192560	Brake Arm
30	173984	Screw Thdrol.	191	192561	Brake Spacer
31	187690	Washer, Spacer	193	193413	Keeper Belt RH Mandrel
32	153532	Pulley, Mandrel	194	194105	Brake Guard
33	400234	Nut, Toplock	195	19133210	Washer 13/32 x 2 x 10 Ga.
36	131494	Pulley, Idler, Flat	214	193782	Bolt/Washer Asm. 5/16-18
37	193198	Pulley, Idler, Flat	--	192870	Mandrel Assembly (Includes Hous- ing, Shaft and Shaft Hardware Only - Pulley Not Included)
40	73680600	Nut, Crownlock 3/8-16 unc	--	192558	Brake Assembly
45	4497H	Retainer	--	193646	Replacement Mower, Complete
55	133840	Idler Arm Assembly			
56	165723	Spacer, Retainer			
67	106932X	Knob			
68	193214	V-Belt			

NOTE: All component dimensions given in U.S. inches
1 inch = 25.4 mm

TRACTOR - - MODEL NUMBER 609140

MOWER LIFT

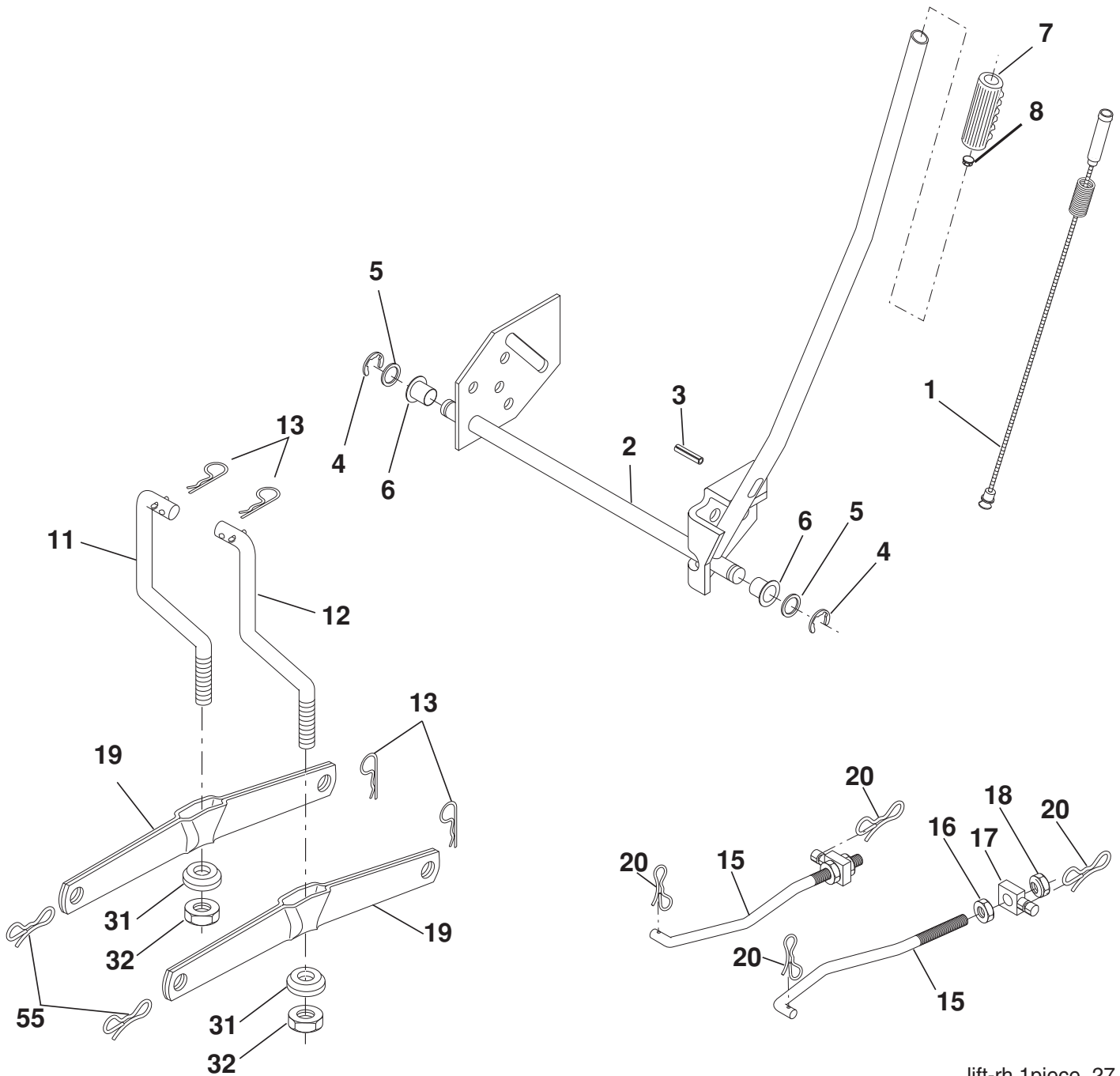

KEY NO.	PART NO.	DESCRIPTION
1	404981	Plunger Asm Lift Lever
2	159471	Shaft Asm Lift RH
3	105767X	Pin Groove 1 500 Zinc
4	12000002	E Ring #5133-62
5	19211621	Washer 21/32 x 1 x 21 Ga.
6	120183X	Bearing Nylon Blk 629 Id
7	109413X	Grip Handle Bicycle Matte Blk
8	124526X	Button Plunger Black
11	139865	Link Lift LH Fixed Length
12	139866	Link Lift RH Fixed Length
13	4939M	Retainer Spring

KEY NO.	PART NO.	DESCRIPTION
15	173288	Link Front
16	73350800	Nut Jam Hex 1/2-13 unc
17	175689	Trunnion
18	73800800	Nut Lock w/Wsh 1/2-13 unc
19	139868	Arm Suspension Rear
20	194209	Pin Cotter 7/16 Bow Tie Lock
31	169865	Bearing Pvt Lift
32	73540600	Nut Crownlock 3/8-24
55	194208	Pin Cotter 5/16

NOTE: All component dimensions given in U.S. inches
1 inch = 25.4 mm.

TRACTOR - - MODEL NUMBER 609140

SEAT

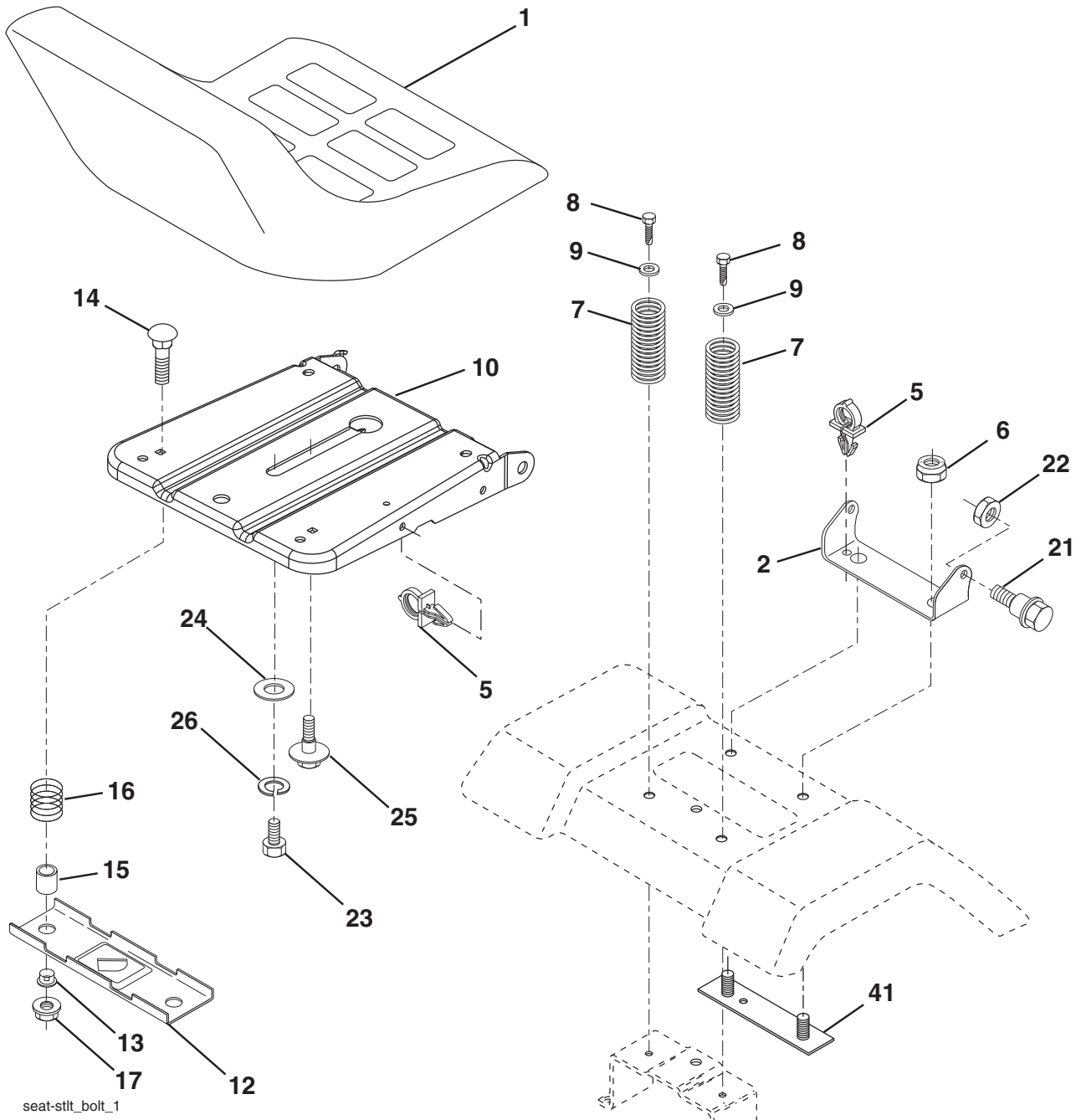

seat-stflt_bolt_1

KEY NO.	PART NO.	DESCRIPTION
1	401042	Seat
2	140551	Bracket Seat Pivot
5	145006	Clip Push-In Hinged
6	73800600	Nut Lock Hex w/Ins 3/8 - 16
7	124181X	Spring Seat Cprsn 2 250 Blk Zi
8	17000616	Screw 3/8-16 x 1.5
9	19131614	Washer 13/32 x 1 x 14 Ga.
10	195530	Pan Asm. Seat
12	174648	Bracket Pnt Mounting Switch
13	121248X	Bushing Snap Blk Nyl
14	72050412	Bolt Rdhd Sht Nk 1/4 - 20 x 1 -1/2
15	134300	Spacer Split .28 x .96

KEY NO.	PART NO.	DESCRIPTION
16	121250X	Spring Cprsn
17	123976X	Nut Lock 1/4 Lge Flg
21	171852	Bolt Shoulder 5/16-18 unc-2A
22	73800500	Nut Lock Hex w/Ins 5/16 - 18
23	71110814	Bolt Hex
24	19171912	Washer 17/32 x 1-3/16 x 12 Ga.
25	127018X	Bolt Shoulder 5/16-18 x .62
26	10040800	Washer Lock Hvy Hlcl Spr 1/2
41	140675	Strap Assembly

NOTE: All component dimensions given in U.S. inches
1 inch = 25.4 mm.

TRACTOR - - MODEL NUMBER 609140

DECALS

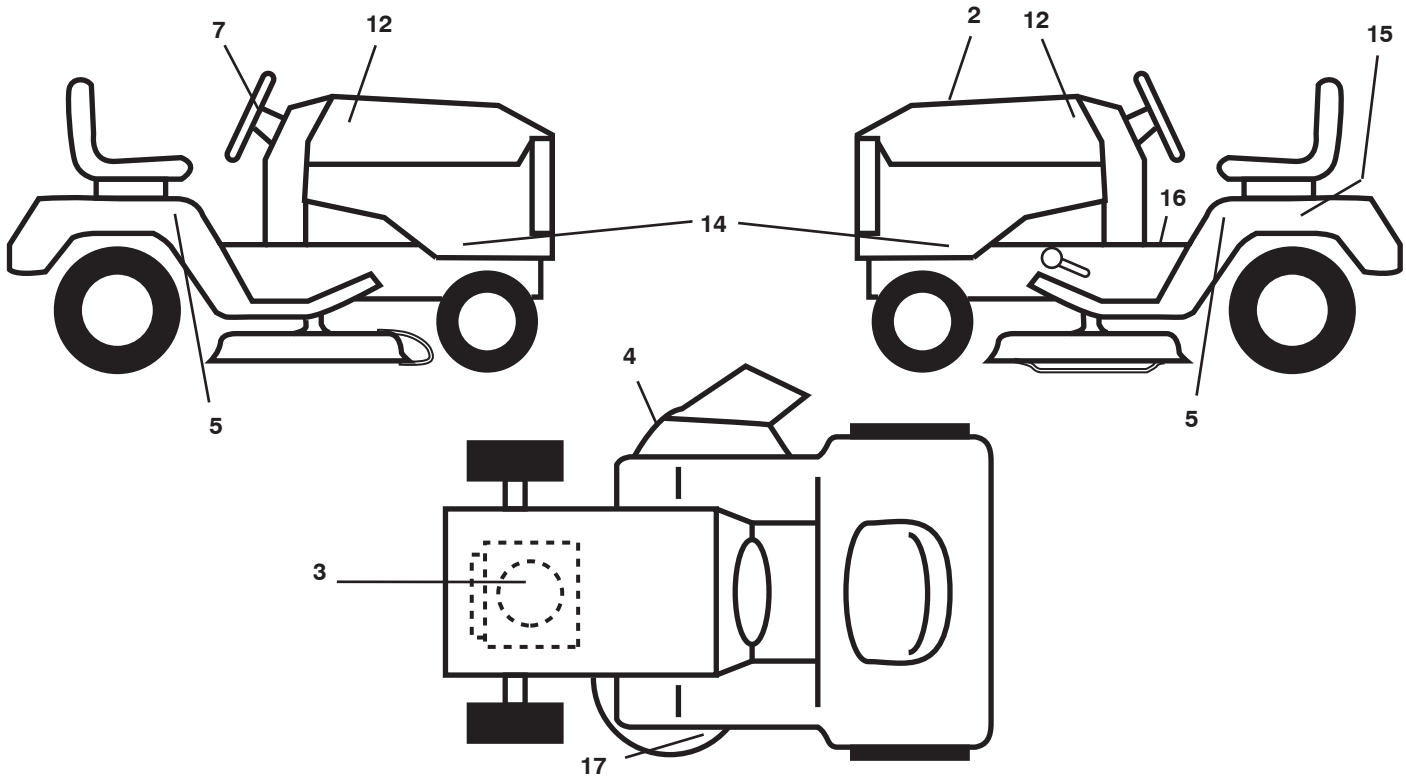

KEY NO.	PART NO.	DESCRIPTION
2	405121	Decal, Replacement
3	408815	Decal, Engine HP
4	170563	Decal, Warning
5	195979	Decal, Fender Sides
7	427365	Decal, Ins Str Wh
12	424667	Decal, Hood
14	427366	Decal, Side PNL

KEY NO.	PART NO.	DESCRIPTION
15	145005	Decal, Caution, Battery
16	411658	Decal, Fender Warning
17	194302	Decal, V-Belt Sch.
--	138311	Decal, Handle Lft Height Adj.
--	184310X428	Pad, Footrest LH
--	184311X428	Pad, Footrest RH
--	426597	Manual, Operator's E&F
--	426598	Manual, Parts E&F

WHEELS & TIRES

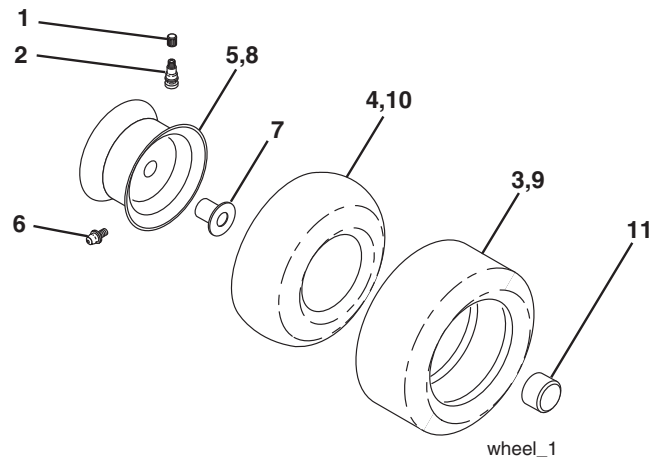

KEY NO.	PART NO.	DESCRIPTION
1	59192	Cap, Tire valve
2	65139	Stem, Valve
3	124157X	Tire, Front
4	59904	Tube, Front (Service item only)
5	106732X624	Rim assembly, 6" Front
6	278H	Fitting, Grease (Front wheel only)
7	9040H	Bearing, Flange (Front wheel only)
8	106108X624	Rim assembly, 8" Rear
9	123969X	Tire, Rear
10	7152J	Tube, Rear (Service item only)
11	104757X428	Cap, Hub Axle
--	144334	Sealant, Tire (10 oz. Tube)

NOTE: All component dimensions given in U.S. inches
1 inch = 25.4 mm