

SEARS

**OWNER'S
MANUAL**

**MODEL NO.
944.621534**

**Important:
Read and follow
all Safety Rules
and Instructions
Before Operating
This Equipment**

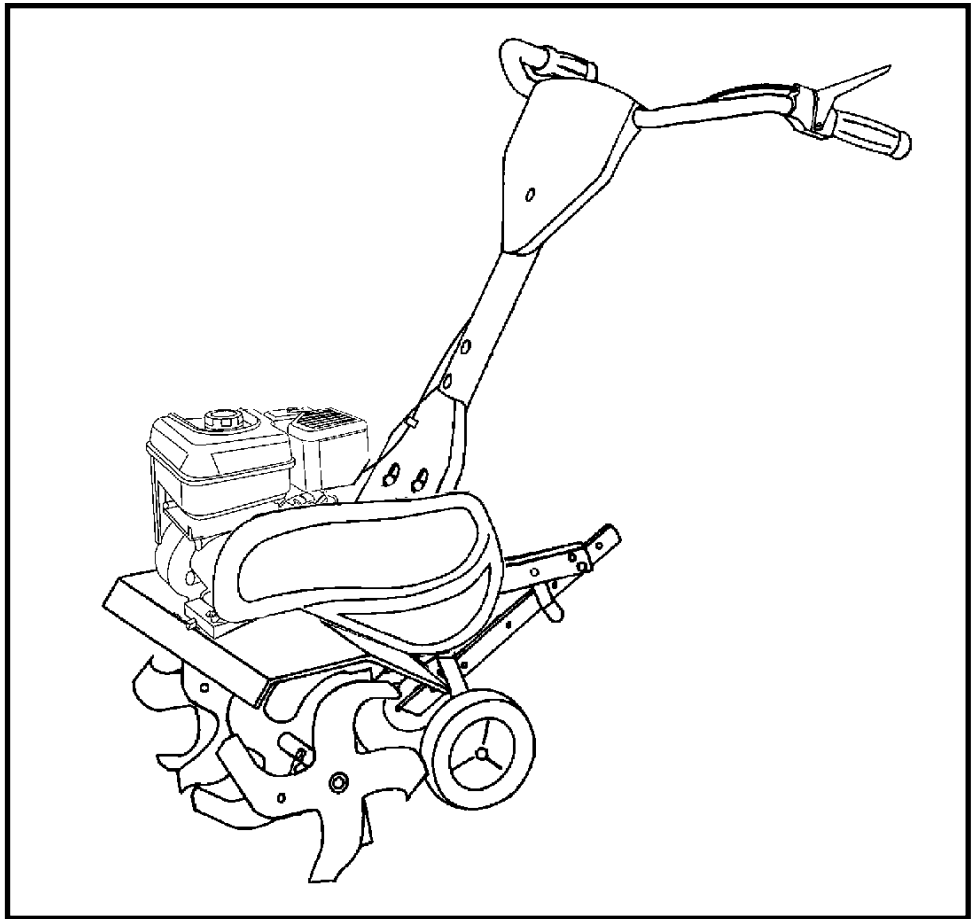

CRAFTSMAN®

**5.5 HP
24 INCH TINE WIDTH
FRONT TINE TILLER**

- **Assembly**
- **Operation**
- **Maintenance**
- **Service and Adjustments**
- **Repair Parts**

SAFETY RULES



SAFE OPERATION PRACTICES FOR WALK-BEHIND POWERED ROTARY TILLERS



TRAINING

- Read the Owner's Manual carefully. Be thoroughly familiar with the controls and the proper use of the equipment. Know how to stop the unit and disengage the controls quickly.
- Never allow children to operate the equipment. Never allow adults to operate the equipment without proper instruction.
- Keep the area of operation clear of all persons, particularly small children, and pets.

PREPARATION

- Thoroughly inspect the area where the equipment is to be used and remove all foreign objects.
- Disengage all clutches and shift into neutral before starting the engine (motor).
- Do not operate the equipment without wearing adequate outer garments. Wear footwear that will improve footing on slippery surfaces.
- Handle fuel with care; it is highly flammable.
- Use an approved fuel container.
- Never add fuel to a running engine or hot engine.
- Fill fuel tank outdoors with extreme care. Never fill fuel tank indoors.
- Replace gasoline cap securely and clean up spilled fuel before restarting.
- Use extension cords and receptacles as specified by the manufacturer for all units with electric drive motors or electric starting motors.
- Never attempt to make any adjustments while the engine (motor) is running (except where specifically recommended by manufacturer).

OPERATION

- Do not put hands or feet near or under rotating parts.
- Exercise extreme caution when operating on or crossing gravel drives, walks, or roads. Stay alert for hidden hazards or traffic. Do not carry passengers.
- After striking a foreign object, stop the engine (motor), remove the wire from the spark plug, thoroughly inspect the tiller for any damage, and repair the damage before restarting and operating the tiller.
- Exercise caution to avoid slipping or falling.
- If the unit should start to vibrate abnormally, stop the engine (motor) and check immediately for the cause. Vibration is generally a warning of trouble.
- Stop the engine (motor) when leaving the operating position.
- Take all possible precautions when leaving the machine unattended. Disengage the tines, shift into neutral, and stop the engine.
- Before cleaning, repairing, or inspecting, shut off the engine and make certain all moving parts have stopped. Disconnect the spark plug wire, and keep the wire away from the plug to prevent accidental starting. Disconnect the cord on electric motors.

- Do not run the engine indoors; exhaust fumes are dangerous.
- Never operate the tiller without proper guards, plates, or other safety protective devices in place.
- Keep children and pets away.
- Do not overload the machine capacity by attempting to till too deep at too fast a rate.
- Never operate the machine at high speeds on slippery surfaces. Look behind and use care when backing.
- Never allow bystanders near the unit.
- Use only attachments and accessories approved by the manufacturer of the tiller.
- Never operate the tiller without good visibility or light.
- Be careful when tilling in hard ground. The tines may catch in the ground and propel the tiller forward. If this occurs, let go of the handlebars and do not restrain the machine.

MAINTENANCE AND STORAGE

- Keep machine, attachments, and accessories in safe working condition.
- Check shear pins, engine mounting bolts, and other bolts at frequent intervals for proper tightness to be sure the equipment is in safe working condition.
- Never store the machine with fuel in the fuel tank inside a building where ignition sources are present, such as hot water and space heaters, clothes dryers, and the like. Allow the engine to cool before storing in any enclosure.
- Always refer to the operator's guide instructions for important details if the tiller is to be stored for an extended period.

- IMPORTANT -

CAUTIONS, IMPORTANTS, AND NOTES ARE A MEANS OF ATTRACTING ATTENTION TO IMPORTANT OR CRITICAL INFORMATION IN THIS MANUAL.

IMPORTANT: USED TO ALERT YOU THAT THERE IS A POSSIBILITY OF DAMAGING THIS EQUIPMENT.

NOTE: Gives essential information that will aid you to better understand, incorporate, or execute a particular set of instructions.



Look for this symbol to point out important safety precautions. It means CAUTION!!! BECOME ALERT!!! YOUR SAFETY IS INVOLVED.



CAUTION: Always disconnect spark plug wire and place wire where it cannot contact spark plug in order to prevent accidental starting when setting up, transporting, adjusting or making repairs.

PRODUCT SPECIFICATIONS

GASOLINE CAPACITY:	3 Quarts (2,8L) Unleaded Regular
OIL (API-SG-SL): (Capacity: 20 oz. [0.6L])	SAE 30 (Above 32°F) SAE 5w-30 (Below 32°F)
SPARK PLUG : (GAP: .030" [0.76mm])	Champion RC12YC

CONGRATULATIONS on your purchase of a tiller. It has been designed, engineered and manufactured to give you the best possible dependability and performance.

Should you experience any problems you cannot easily remedy, please contact your nearest authorized service centre/department. They have competent, well-trained technicians and the proper tools to service or repair this unit.

Please read and retain this manual. The instructions will enable you to assemble and maintain your tiller properly. Always observe the "SAFETY RULES".

MAINTENANCE AGREEMENT

A Sears Maintenance Agreement is available on this product. Contact your nearest Sears store for details.

CUSTOMER RESPONSIBILITIES

- Read and observe the safety rules.
- Follow a regular schedule in maintaining, caring for and using your tiller.
- Follow the instructions under "Maintenance" and "Storage" sections of this Owner's Manual.

IMPORTANT: THIS UNIT IS EQUIPPED WITH AN INTERNAL COMBUSTION ENGINE AND SHOULD NOT BE USED ON OR NEAR ANY UNIMPROVED FOREST-COVERED, BRUSH-COVERED OR GRASS COVERED LAND UNLESS THE ENGINE'S EXHAUST SYSTEM IS EQUIPPED WITH A SPARK ARRESTER MEETING APPLICABLE LOCAL OR STATE LAWS (IF ANY). IF A SPARK ARRESTER IS USED, IT SHOULD BE MAINTAINED IN EFFECTIVE WORKING ORDER BY THE OPERATOR.

SEE YOUR AUTHORIZED SERVICE CENTRE/DEPARTMENT FOR SPARK ARRESTER. REFER TO THE REPAIR PARTS SECTION OF THIS MANUAL FOR PART NUMBER.

LIMITED TWO (2) YEAR WARRANTY ON CRAFTSMAN TILLER

For Two (2) years from date of purchase Sears Canada, Inc. will repair or replace at Sears option free of charge parts which are defective as a result of material or workmanship.

COMMERCIAL OR RENTAL USE:

Warranty on Tiller will be thirty (30) days from date of purchase if used for commercial or rental purposes.

This Warranty does **NOT** cover:

1. Pre-delivery set-up.
2. Expendable items which become worn during normal use, such as tines, spark plugs, air cleaners, shear pins, and belts.
3. Repairs necessary because of operator abuse or negligence, including the failure to operate and maintain the equipment according to the instructions contained in the Owner's Manual.

Warranty service is available by returning the Craftsman Tiller to the nearest Sears Service Centre/Department in Canada. This warranty applies only while this product is in use in Canada.

This warranty is in addition to any statutory warranty and does not exclude or limit legal rights you may have but shall run concurrently with applicable provincial legislation. Furthermore, some provinces do NOT allow limitation on how long an implied warranty will last so the above limitations may not apply to you.

SEARS CANADA, INC., TORONTO, ONTARIO M5B 2B8

TABLE OF CONTENTS

SAFETY RULES	2
CUSTOMER RESPONSIBILITIES.....	3
PRODUCT SPECIFICATIONS.....	3
WARRANTY.....	3
ASSEMBLY.....	4-5
OPERATION	6-9
MAINTENANCE SCHEDULE	10

MAINTENANCE	10-12
SERVICE & ADJUSTMENTS	12-14
STORAGE	15
TROUBLESHOOTING	16
REPAIR PARTS-TILLER.....	17-22
REPAIR PARTS-ENGINE.....	23-28
SERVICE/PARTS ORDERING.....	BACK COVER

ASSEMBLY

Your new tiller has been assembled at the factory with exception of those parts left unassembled for shipping purposes. To ensure safe and proper operation of your tiller all parts and hardware you assemble must be tightened securely. Use the correct tools as necessary to insure proper tightness.

TOOLS REQUIRED FOR ASSEMBLY

A socket wrench set will make assembly easier. Standard wrench sizes are listed.

- (1) Utility knife
- (1) Screwdriver
- (1) Pair of pliers
- (2) 1/2" wrenches

OPERATOR'S POSITION (See Fig. 1)

When right or left hand is mentioned in this manual, it means when you are in the operating position (standing behind tiller handles).

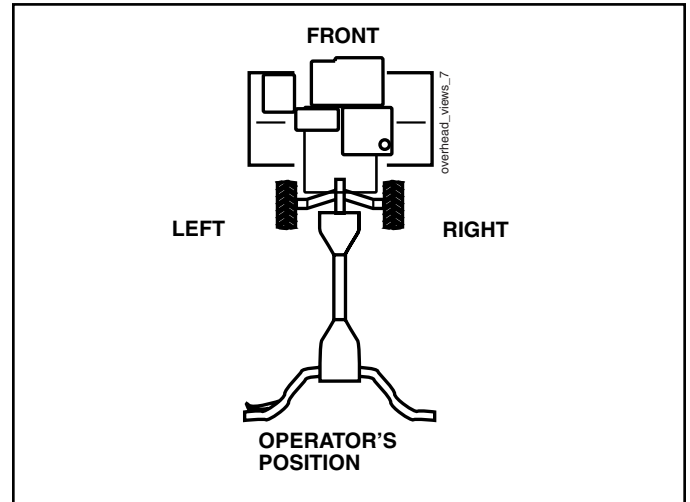
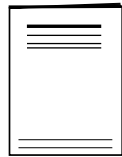
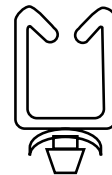

FIG. 1

CONTENTS OF HARDWARE PACK



(1) Manual



(1) Plastic Cable Clip

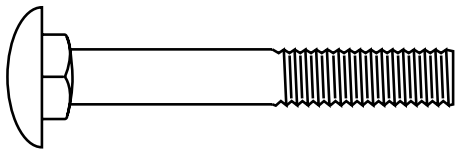

(2) Carriage Bolts 5/16-18 UNC x 2-3/8 Gr. 5

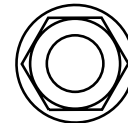

(2) Flange Locknuts 5/16-18 UNC

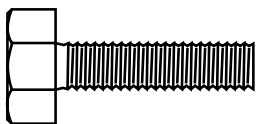

(2) Hex Bolts 5/16-18 x 1-1/4



(1) Bottle Engine Oil

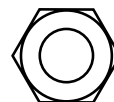

(2) Hex Nuts 5/16-18

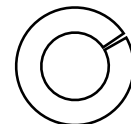

(2) Lock Washers 5/16

ASSEMBLY

UNPACK CARTON & INSTALL HANDLE (See Fig. 2)



CAUTION: Be careful of exposed staples when handling or disposing of cartoning material.

IMPORTANT: WHEN UNPACKING AND ASSEMBLING TILLER, BE CAREFUL NOT TO STRETCH OR KINK CABLE(S).

- Cut cable ties securing handle column.
- Route cable(s) as shown and slide handle column onto handle mount.
- Remove all packing from carton.
- Secure handle column using two (2) carriage bolts and two (2) flange locknuts. Tighten securely.
- Cut away carton.
- Route tine control cable(s) through plastic cable clip on handle mount.

NOTE: Cables must not touch the muffler.

- Cut cable ties securing tiller to skid. Remove tiller from skid by pulling backwards.
- Remove screws securing depth stake to skid and discard the screws.

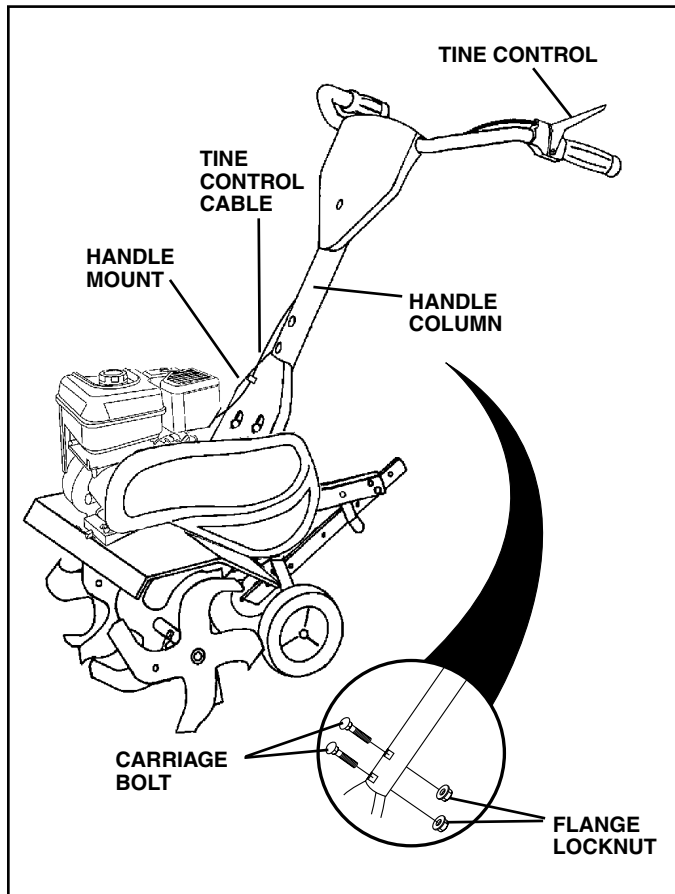

FIG. 2

INSTALL DEPTH STAKE ASSEMBLY (See Fig. 3)

- Loosen nut "A".
- Insert stake support between engine bracket halves with stake spring down.
- Bolt stake support to engine brackets with bolts, lock washers and nuts. Tighten securely. Tighten nut "A".
- Depth stake must move freely. If it does not, loosen support bolt.

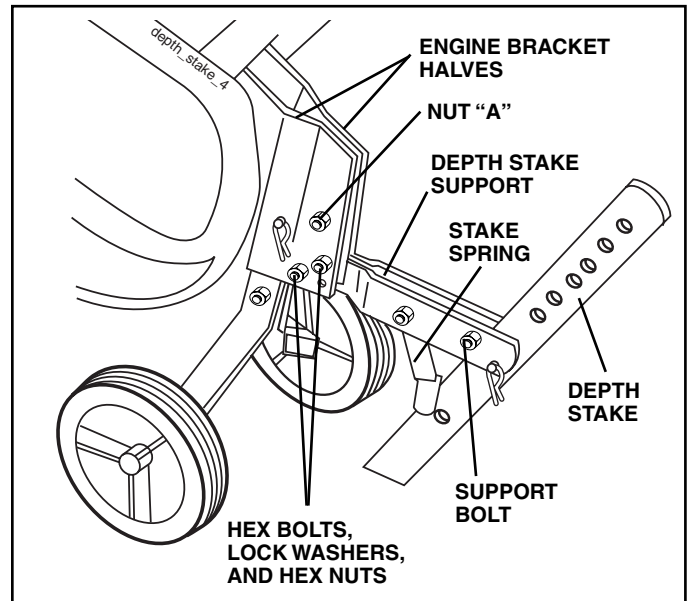

FIG. 3

HANDLE HEIGHT

- Handle height may be adjusted to better suit operator. (See "HANDLE HEIGHT" in the Service and Adjustments section of this manual).

TILLING WIDTH

- Tilling width may be adjusted to better handle your tilling conditions (See "TINE ARRANGEMENT" in the Service and Adjustments section of this manual).

TINE OPERATION

- Check tine operation before first use. (See "TINE OPERATION CHECK" in the Service and Adjustments section of this manual).

OPERATION

KNOW YOUR TILLER

READ THIS OWNER'S MANUAL AND SAFETY RULES BEFORE OPERATING YOUR TILLER

Compare the illustrations with your tiller to familiarize yourself with the locations of various controls and adjustments. Save this manual for future reference.

These symbols may appear on your tiller or in literature supplied with the product. Learn and understand their meaning.

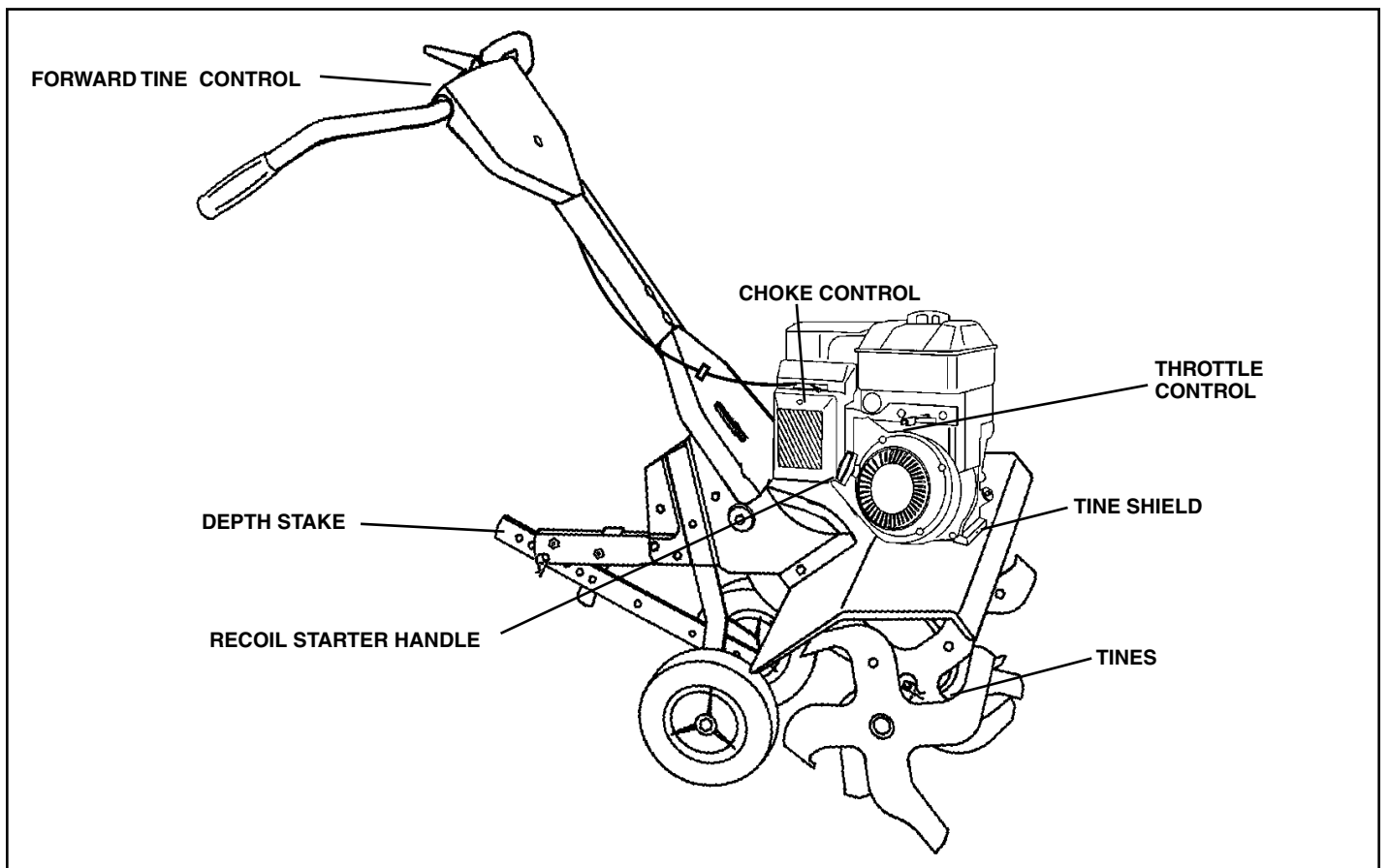
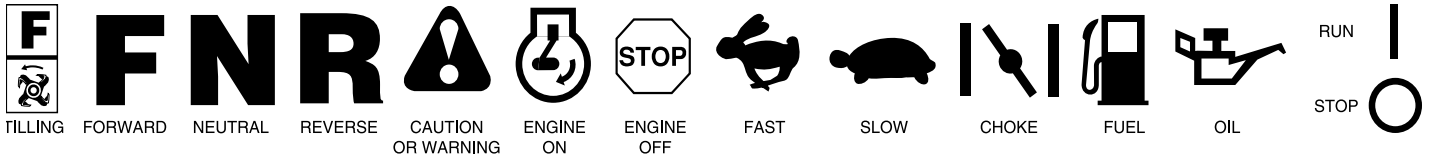

FIG. 4

MEETS ANSI SAFETY REQUIREMENTS

Our tillers conform to the safety standards of the American National Standards Institute.

FORWARD TINE CONTROL - Engages tines in forward direction.

CHOKE CONTROL - Used when starting a cold engine.

THROTTLE CONTROL - Controls engine speed.

DEPTH STAKE - Controls forward speed and the depth at which the tiller will dig.

RECOIL STARTER HANDLE - Used to start the engine.

OPERATION



The operation of any tiller can result in foreign objects thrown into the eyes, which can result in severe eye damage. Always wear safety glasses or eye shields before starting your tiller and while tilling. We recommend a wide vision safety mask over spectacles or standard safety glasses.

HOW TO USE YOUR TILLER

Know how to operate all controls before adding fuel and oil or attempting to start engine.

STOPPING (See Fig. 5)

TINES

- Release tine control to stop movement.

ENGINE

- Move throttle control to “STOP” position.
- Never use choke to stop engine.

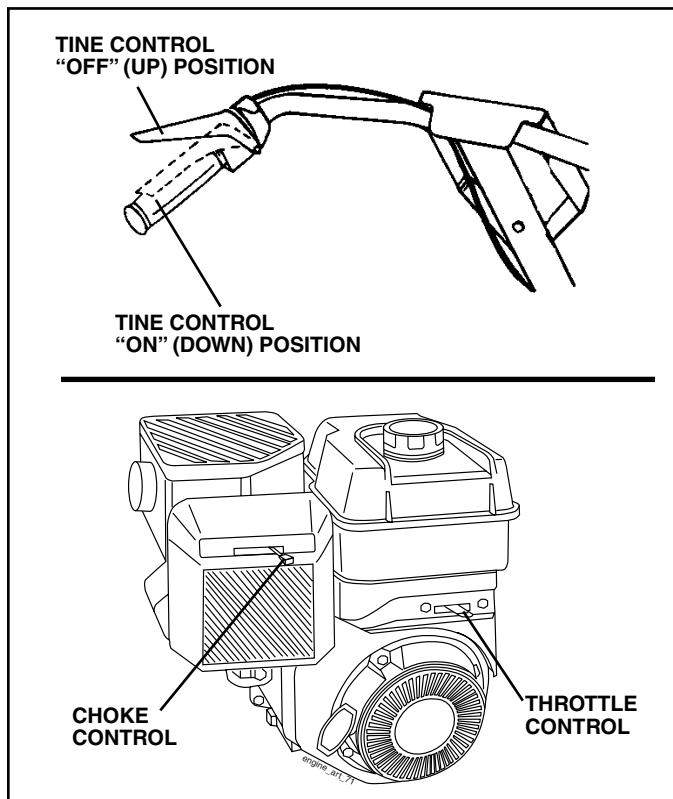

FIG. 5

TINE OPERATION (See Fig. 5)

- Squeeze tine control to handle.

TILLING

The speed and depth of tilling is regulated by the position of the depth stake and wheel height.

The depth stake should always be below the wheels for digging. It serves as a brake to slow the tiller's forward motion to enable the tines to penetrate the ground. Also, the more the depth stake is lowered into the ground the deeper the tines will dig.

DEPTH STAKE (See Fig. 6)

Adjust depth stake by removing the hairpin clip and clevis pin. Change depth stake to desired position. Replace the clevis pin and hairpin clip.

- For normal tilling, set depth stake at the second or third hole from the top.

WHEELS (See Fig. 6)

Adjust wheels by removing the hairpin clip and clevis pin. Change wheel position. Replace the hairpin clip and clevis pin.

- For normal tilling, set wheels at the second or third hole from the top.

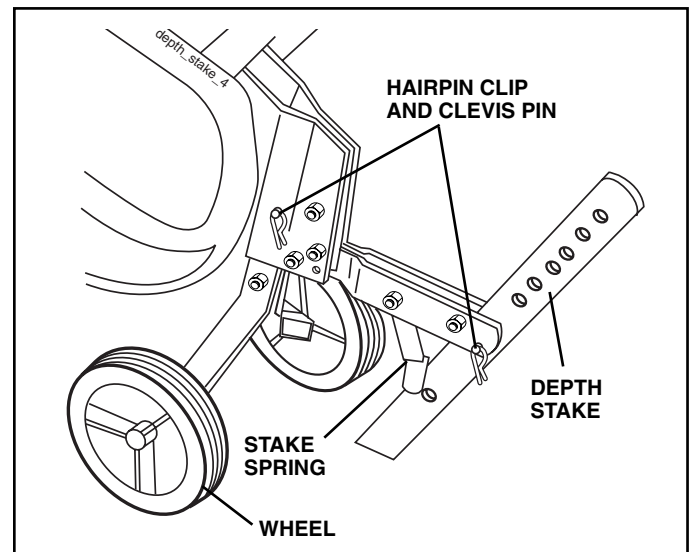

FIG. 6

TO TRANSPORT



CAUTION: Before lifting or transporting, allow tiller engine and muffler to cool. Disconnect spark plug wire. Drain gasoline from fuel tank.

AROUND THE YARD

- Tip depth stake forward until it is held by the stake spring.
- Push tiller handles down, raising tines off the ground.
- Push or pull tiller to desired location.

AROUND TOWN

- Disconnect spark plug wire.
- Drain fuel tank.
- Transport in upright position to prevent oil leakage.

OPERATION

BEFORE STARTING ENGINE

IMPORTANT: BE VERY CAREFUL NOT TO ALLOW DIRT TO ENTER THE ENGINE WHEN CHECKING OR ADDING OIL OR FUEL. USE CLEAN OIL AND FUEL AND STORE IN APPROVED, CLEAN, COVERED CONTAINERS. USE CLEAN FILL FUNNELS.

FILL ENGINE WITH OIL (See Fig. 7)

- With engine level, remove engine oil filler plug.
- Fill engine with oil to point of overflowing. For approximate capacity see "PRODUCT SPECIFICATIONS" on page 3 of this manual.
- Tilt tiller back on its wheels and then re-level.
- With engine level, refill to point of overflowing if necessary. Replace oil filler plug.
- For cold weather operation you should change oil for easier starting (See "OIL VISCOSITY CHART" in the Maintenance section of this manual).
- To change engine oil, see the Maintenance section of this manual.

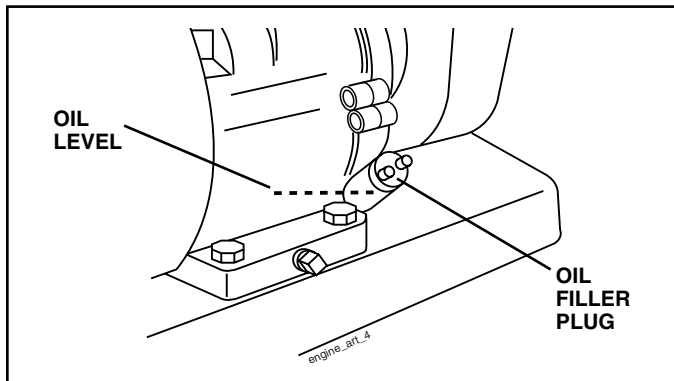

FIG. 7

ADD GASOLINE

- Fill fuel tank to bottom of filler neck. Do not overfill. Use fresh, clean, regular unleaded gasoline with a minimum of 87 octane. (Use of leaded gasoline will increase carbon and lead oxide deposits and reduce valve life). Do not mix oil with gasoline. Purchase fuel in quantities that can be used within 30 days to assure fuel freshness.



CAUTION: Fill to within 1/2 inch of top of fuel tank to prevent spills and to allow for fuel expansion. If gasoline is accidentally spilled, move machine away from area of spill. Avoid creating any source of ignition until gasoline vapors have disappeared.

Wipe off any spilled oil or fuel. Do not store, spill or use gasoline near an open flame.

IMPORTANT: WHEN OPERATING IN TEMPERATURES BELOW 32°F (0°C), USE FRESH, CLEAN WINTER GRADE GASOLINE TO HELP INSURE GOOD COLD WEATHER STARTING.

CAUTION: Alcohol blended fuels (called gasohol or using ethanol or methanol) can attract moisture which leads to separation and formation of acids during storage. Acidic gas can damage the fuel system of an engine while in storage. To avoid engine problems, the fuel system should be emptied before storage of 30 days or longer. Drain the gas tank, start the engine and let it run until the fuel lines and carburetor are empty. Use fresh fuel next season. See Storage Instructions for additional information. Never use engine or carburetor cleaner products in the fuel tank or permanent damage may occur.

TO START ENGINE (See Fig. 8)



CAUTION: Keep tine control in "OFF" position when starting engine.

When starting engine for the first time or if engine has run out of fuel, it will take extra pulls of the recoil starter to move fuel from the tank to the engine.

- Make sure spark plug wire is properly connected.
- Place throttle control in "FAST" position.
- Move choke control to full "CHOKE" position. Grasp recoil starter handle with one hand and grasp tiller handle with other hand. Pull rope out slowly until engine reaches start of compression cycle (rope will pull slightly harder at this point).
- Pull recoil starter handle quickly. Do not let starter handle snap back against starter. Repeat if necessary.
- If engine fires but does not start, move choke control to half choke position. Pull recoil starter handle until engine starts.
- When engine starts, slowly move choke control to "RUN" position as engine warms up.

NOTE: A warm engine requires less choking to start.

- Move throttle control to desired running position.
- Allow engine to warm up for a few minutes before engaging tines.

NOTE: If at a high altitude (3000 feet) or in cold temperatures (below 32°F), the carburetor fuel mixture may need to be adjusted for best engine performance. See "TO ADJUST CARBURETOR" in the Service and Adjustments section of this manual.

NOTE: If engine does not start, see troubleshooting points.

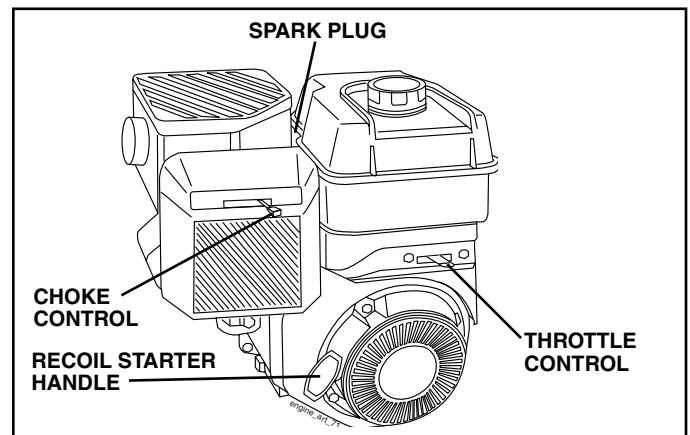

FIG. 8

OPERATION

BREAKING IN YOUR TILLER

Break-in your belt(s), pulleys and tine control before you actually begin tilling.

- Start engine, tip tines off ground by pressing handles down and engage tine control to start tine rotation. Allow tines to rotate for five minutes.
- Check tine operation and adjust if necessary. See "TINE OPERATION CHECK" in the Service and Adjustments section of this manual.

TILLING HINTS



CAUTION: Until you are accustomed to handling your tiller, start actual field use with throttle in slow position.

To help tiller move forward, lift up the handles slightly (thus lifting depth stake out of ground). To slow down the tiller, press down on handles.

If you are straining or tiller is shaking, the wheels and depth stake are not set properly in the soil being tilled. The proper setting of the wheels and depth stake is through trial and error and depends upon the soil condition. (The harder or wetter the ground, the slower the engine and tine speed needed. Under these poor conditions, at fast speed the tiller will run and jump over the ground).

A properly adjusted tiller will dig with little effort from the operator.

- Tilling is digging into, turning over, and breaking up packed soil before planting. Loose, unpacked soil helps root growth. Best tilling depth is 4"-6". A tiller will also clear the soil of unwanted vegetation. The decomposition of this vegetable matter enriches the soil. Depending on the climate (rainfall and wind), it may be advisable to till the soil at the end of the growing season to further condition the soil.
- Soil conditions are important for proper tilling. Tines will not readily penetrate dry, hard soil which may contribute to excessive bounce and difficult handling of your tiller. Hard soil should be moistened before tilling; however, extremely wet soil will "ball-up" or clump during tilling. Wait until the soil is less wet in order to achieve the best results. When tilling in the fall, remove vines and long grass to prevent them from wrapping around the tine shaft and slowing your tilling operation.
- You will find tilling much easier if you leave a row untilled between passes. Then go back between tilled rows. (See Fig. 9) There are two reasons for doing this. First, wide turns are much easier to negotiate than about-faces. Second, the tiller won't be pulling itself, and you, toward the row next to it.
- Set depth stake and wheel height for shallow tilling when working extremely hard soil or sod. Then work across the first cuts at normal depth.

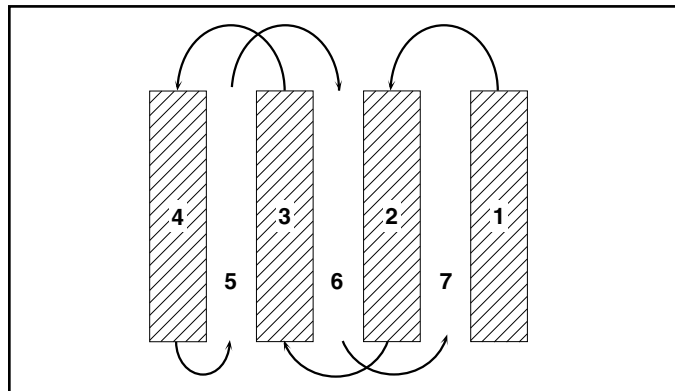

FIG. 9

CULTIVATING

Cultivating is destroying the weeds between rows to prevent them from robbing nourishment and moisture from the plants. At the same time, breaking up the upper layer of soil crust will help retain moisture in the soil. Best digging depth is 1"-3".

- You will probably not need to use the depth stake. Begin by tipping the depth stake forward until it is held by the stake spring.
- Cultivate up and down the rows at a speed which will allow tines to uproot weeds and leave the ground in rough condition, promoting no further growth of weeds and grass (See Fig. 10).

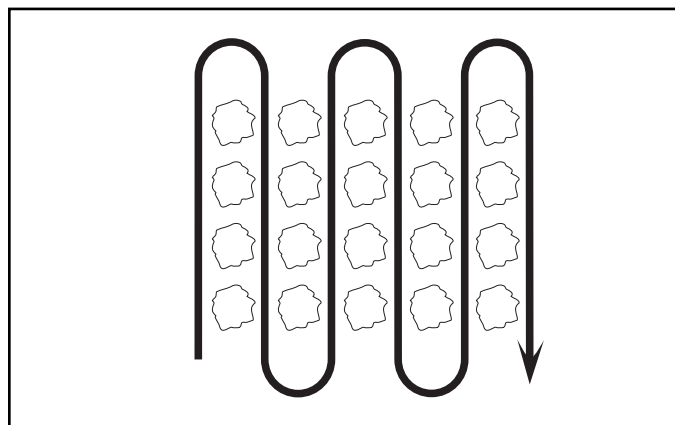

FIG. 10

MAINTENANCE

MAINTENANCE SCHEDULE					SERVICE DATES														
	BEFORE EACH USE	EVERY 5 HOURS	EVERY 25 HOURS	EVERY 50 HOURS															
FILL IN DATES AS YOU COMPLETE REGULAR SERVICE																			
Check Engine Oil Level	✓	✓																	
Change Engine Oil			✓ _{1,2}																
Oil Pivot Points		✓																	
Inspect Spark Arrester / Muffler				✓															
Inspect Air Screen	✓																		
Clean or Replace Air Cleaner Cartridge				✓ ₂															
Clean Engine Cylinder Fins				✓															
Replace Spark Plug				✓															

1 - Change more often when operating under a heavy load or in high ambient temperatures.
 2 - Service more often when operating in dirty or dusty conditions.

GENERAL RECOMMENDATIONS

The warranty on this tiller does not cover items that have been subjected to operator abuse or negligence. To receive full value from the warranty, the operator must maintain tiller as instructed in this manual.

Some adjustments will need to be made periodically to properly maintain your tiller.

All adjustments in the Service and Adjustments section of this manual should be checked at least once each season.

- Once a year you should replace the spark plug, clean or replace air filter, and check tines and belts for wear. A new spark plug and clean air filter assure proper air-fuel mixture and help your engine run better and last longer.

BEFORE EACH USE

- Check engine oil level.
- Check tine operation.
- Check for loose fasteners.

LUBRICATION

Keep unit well lubricated (See "LUBRICATION CHART").

LUBRICATION CHART

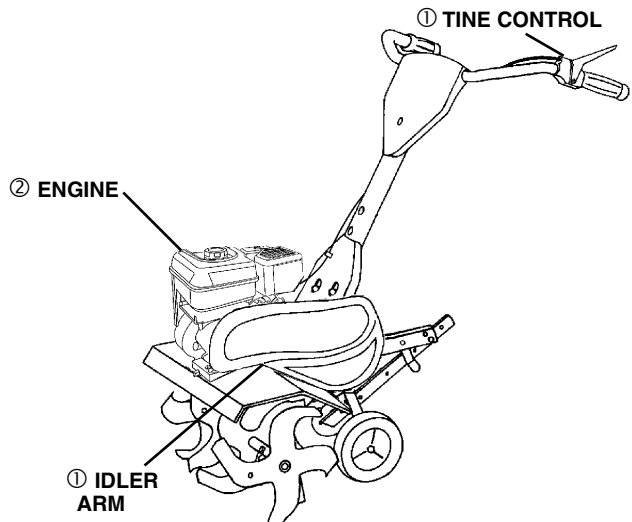

- ① SAE 30 OR 10W-30 MOTOR OIL
- ② REFER TO MAINTENANCE "ENGINE" SECTION

MAINTENANCE



Disconnect spark plug wire before performing any maintenance (except carburetor adjustment) to prevent accidental starting of engine.

Prevent fires! Keep the engine free of grass, leaves, spilled oil, or fuel. Remove fuel from tank before tipping unit for maintenance. Clean muffler area of all grass, dirt, and debris.

Do not touch hot muffler or cylinder fins as contact may cause burns.

ENGINE

LUBRICATION

Use only high quality detergent oil rated with API service classification SG-SL. Select the oil's SAE viscosity grade according to your expected temperature.

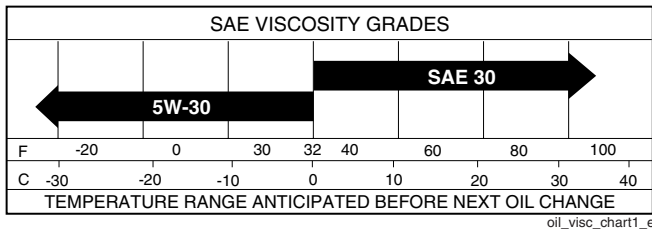

FIG. 11

NOTE: Although multi-viscosity oils (5W-30, 10W-30, etc.) improve starting in cold weather, these multi viscosity oils will result in increased oil consumption when used above 32°F (0°C). Check your engine oil level more frequently to avoid possible engine damage from running low on oil.

Change the oil after every 50 hours of operation or at least once a year if the tiller is not used for 50 hours in one year.

Check the crankcase oil level before starting the engine and after each five (5) hours of continuous use. Add SAE 30 motor oil or equivalent. Tighten oil filler plug securely each time you check the oil level.

TO CHANGE ENGINE OIL (See Figs.11 and 12)

Determine temperature range expected before oil change. All oil must meet API service classification SG-SL.

- Be sure tiller is on level surface.
- Oil will drain more freely when warm.
- Catch oil in a suitable container.
- Remove drain plug.
- Tip tiller forward to drain oil.
- After oil has drained completely, replace oil drain plug and tighten securely.
- Remove oil filler plug. Be careful not to allow dirt to enter the engine.
- Refill engine with oil. See "FILL ENGINE WITH OIL" in the Operation section of this manual.

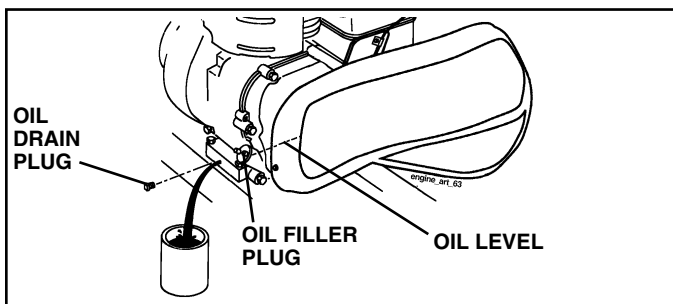

FIG. 12

AIR CLEANER (See Fig. 13)

Service air cleaner cartridge every 50 hours, more often if engine is used in very dusty conditions.

- Loosen air cleaner screws, one on each side of cover.
- Remove air cleaner cover.
- Carefully remove air cleaner cartridge. Be careful. Do not allow dirt or debris to fall into carburetor.
- Clean by tapping gently on a flat surface.
- If very dirty or damaged, replace cartridge.
- Clean and replace cover. Tighten screws securely.



CAUTION: Petroleum solvents, such as kerosene, are not to be used to clean cartridge. They may cause deterioration of the cartridge. Do not oil cartridge. Do not use pressurized air to clean or dry cartridge.

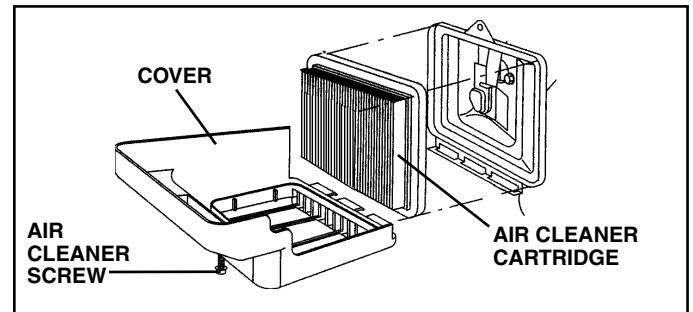

FIG. 13

COOLING SYSTEM (See Fig. 14)

Your engine is air cooled. For proper engine performance and long life keep your engine clean.

- Clean air screen frequently using a stiff-bristled brush.
- Remove blower housing and clean as necessary.
- Keep cylinder fins free of dirt and chaff.

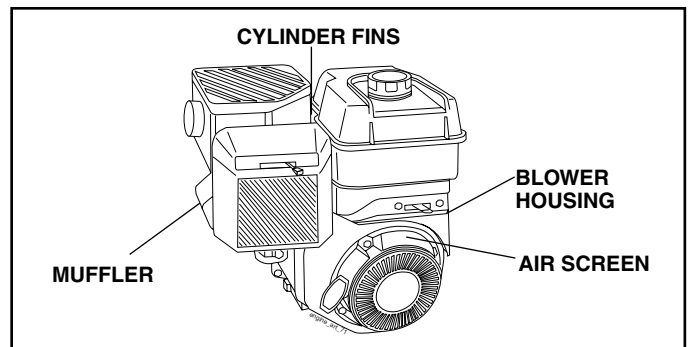

FIG. 14

MAINTENANCE

MUFFLER

Do not operate tiller without muffler. Do not tamper with exhaust system. Damaged mufflers or spark arresters could create a fire hazard. Inspect periodically and replace if necessary. If your engine is equipped with a spark arrester screen assembly, remove every 50 hours for cleaning and inspection. Replace if damaged.

SPARK PLUG

Replace spark plugs at the beginning of each tilling season or after every 50 hours of use, whichever comes first. Spark plug type and gap setting is shown in "PRODUCT SPECIFICATIONS" on page 3 of this manual.

TRANSMISSION

Your transmission is sealed and will only require lubrication if it is serviced.

CLEANING

Do not clean your tiller when the engine and transmission are hot. We do not recommend using pressurized water (garden hose, etc.) to clean your unit unless the gasket area around the transmission and the engine muffler, air filter and carburetor are covered to keep water out. Water in engine will shorten the useful life of your tiller.

- Clean engine, wheels, finish, etc. of all foreign matter.
- Keep finished surfaces and wheels free of all gasoline, oil, etc.
- Protect painted surfaces with automotive type wax.

SERVICE AND ADJUSTMENTS



CAUTION: Disconnect spark plug wire from spark plug and place wire where it cannot come into contact with plug.

TILLER

TO ADJUST HANDLE HEIGHT (SEE FIG. 15)

Factory assembly has provided lowest handle height. Select handle height best suited for your tilling conditions. Handle height will be different when tiller digs into soil.

- If a higher handle height is desired, loosen the four nuts securing handle panel to engine brackets.
- Slide handle panel to desired location.
- Tighten the four nuts securely.

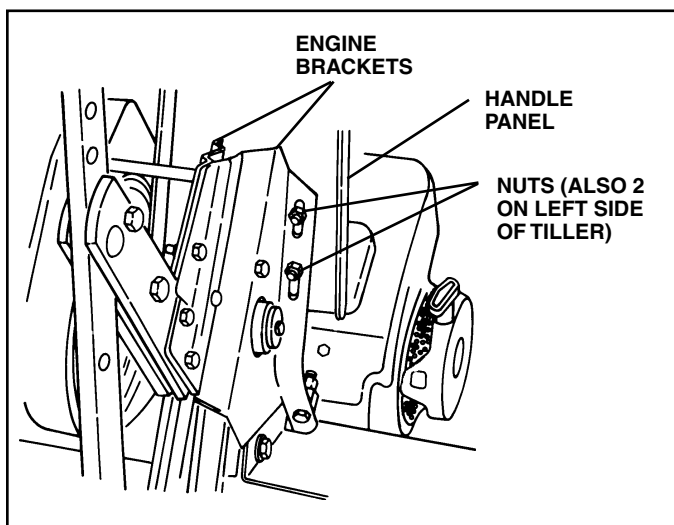

FIG. 15

TINE ARRANGEMENT

Your outer tines can be assembled in several different ways to suit your tilling or cultivating needs.



CAUTION: Tines are sharp. Wear gloves or other protection when handling tines.

NORMAL TILLING - 24" PATH (See Fig. 16)

- Assemble holes "A" in tine hubs to holes "B" in tine shaft.

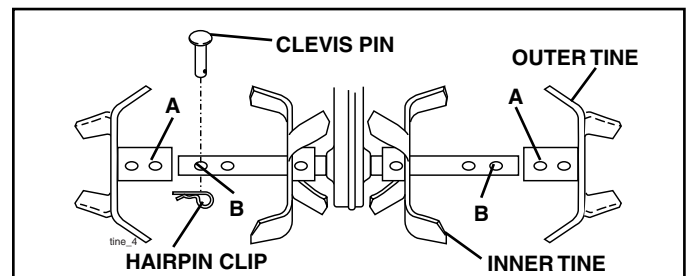

FIG. 16

MID-WIDTH TILLING - 22" PATH (See Fig. 17)

- Assemble holes "A" in tine hubs to holes "C" in tine shaft.

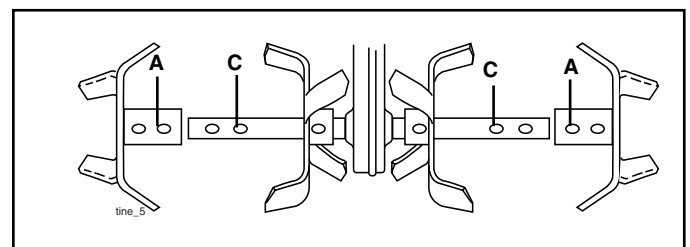

FIG. 17

SERVICE AND ADJUSTMENTS

NARROW TILLING/CULTIVATING - 12-3/4" PATH (See Fig. 18)

- Remove outer tines.

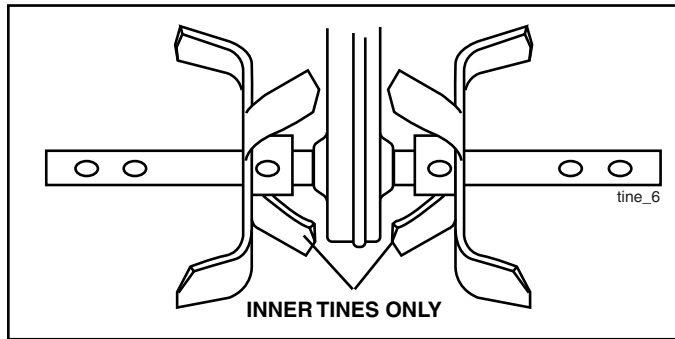

FIG. 18

NOTE: When reassembling outer tines, be sure right tine assembly (marked "R") and left tine assembly (marked "L") are mounted to correct side of tine shaft.

TINE OPERATION CHECK (See Fig. 19)



WARNING: Disconnect spark plug wire from spark plug to prevent starting while checking tine operation.

For proper tine operation, tine control lever must be against control body and all slack removed from inner wire of control cable when control is in the "OFF" (up) position.

If lever and cable are loose, loosen cable clip at lower end of cable. Pull up on cable to remove slack, without extending spring on end of cable, and retighten cable clip.

FINAL CHECK "OFF" POSITION

- With tine control "OFF" (up), push down on handle to raise tines off the ground.
- Slowly pull recoil starter handle while observing tines. Tines should not rotate.
- If tines rotate, inner wire of control cable is too tight which is extending lower spring and engaging tines. Loosen cable clip and push down on cable only enough to relieve spring tension. Tighten cable clip.
- Recheck in "OFF" position and adjust if necessary.

FINAL CHECK "ON" POSITION

- With tine control "ON" (held down to handle) push down on handle to raise tines off the ground.
- Slowly pull recoil starter handle while observing tines. Tines should rotate forward.
- If tines do not rotate, inner wire of control cable is too loose. Loosen cable clip and pull cable up to remove slack and retighten clip.
- Recheck in "ON" position and adjust if necessary.

NOTE: If "ON" position check required adjustment, recheck "OFF" position adjustment to insure tines do not rotate when control is "OFF" (up).

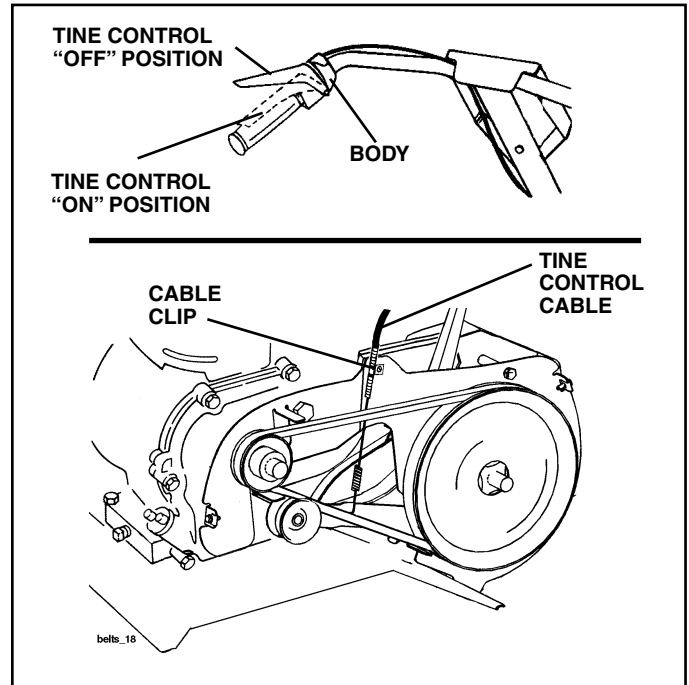

FIG. 19

TO REMOVE BELT GUARD (See Fig. 20)

- Remove screws from sides of belt guard.
- Pull belt guard out and away from unit.
- Replace belt guard by reversing above procedure. Be sure slot in bottom of belt guard is under head of tine shield bolt and all nuts are tightened securely.

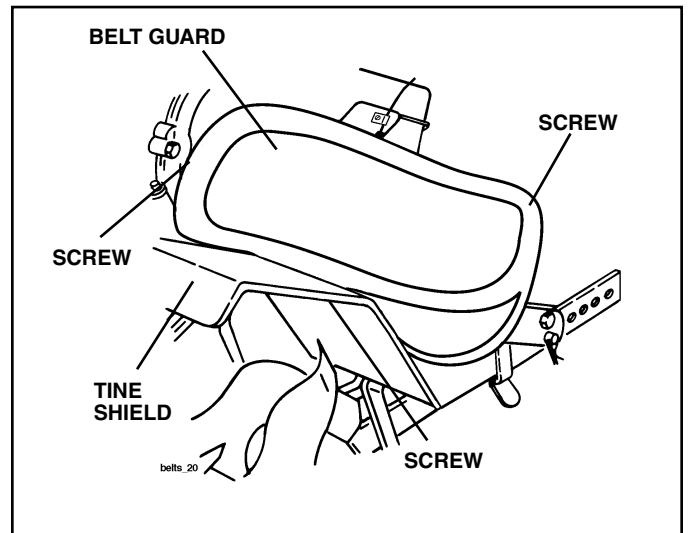

FIG. 20

SERVICE AND ADJUSTMENTS

TO REPLACE V-BELT (See Fig. 21)

Replace V-belt if it has stretched considerably or if it has cracks or frayed edges.

Belt guard must be removed to service belt. See "TO REMOVE BELT GUARD" in this section of manual.

BELT REMOVAL

- Remove V-belt from transmission pulley first and then from engine pulley.

BELT REPLACEMENT

- Install new V-belt to engine pulley first then to transmission pulley. Be sure belt is positioned on inside groove of both pulleys, inside all belt guides and rests on idler pulley.

CHECK TINE OPERATION

- See "TINE OPERATION CHECK" in this section of manual.

REPLACE BELT GUARD

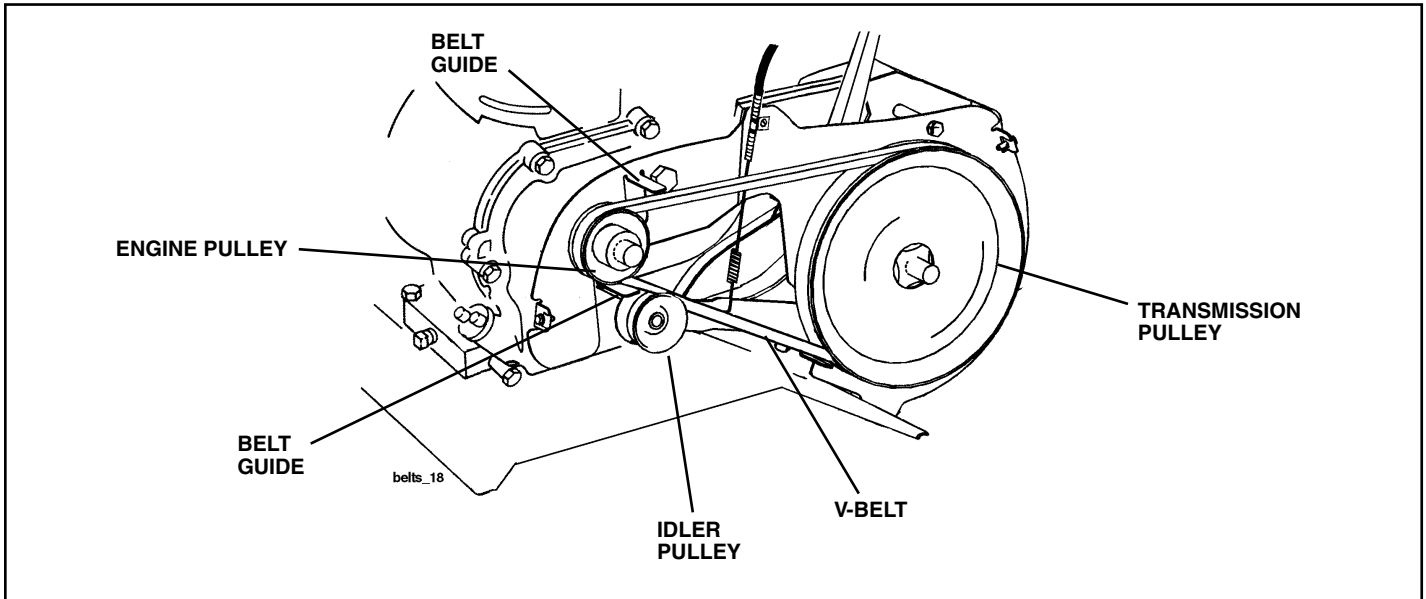

FIG. 21

ENGINE

Maintenance, repair, or replacement of the emission control devices and systems, which are being done at the customer's expense, may be performed by any non-road engine repair establishment or individual. Warranty repairs must be performed by an authorized engine manufacturer's service outlet.

TO ADJUST CARBURETOR

The carburetor has a high speed fixed jet and has been preset at the factory and adjustment should not be necessary. However, minor adjustments may be required to compensate for differences in fuel, temperature, altitude or load. If the carburetor does need adjustment, proceed as follows.

IMPORTANT: NEVER TAMPER WITH THE ENGINE GOVERNOR, WHICH IS FACTORY SET FOR PROPER ENGINE SPEED. OVERSPEEDING THE ENGINE ABOVE THE FACTORY HIGH SPEED SETTING CAN BE DANGEROUS. IF YOU THINK THE ENGINE-GOVERNED HIGH SPEED NEEDS ADJUSTING, CONTACT YOUR NEAREST AUTHORIZED SERVICE CENTER/DEPARTMENT, WHICH HAS THE PROPER EQUIPMENT AND EXPERIENCE TO MAKE ANY NECESSARY ADJUSTMENTS.

STORAGE

Immediately prepare your tiller for storage at the end of the season or if the unit will not be used for 30 days or more.



WARNING: Never store the tiller with gasoline in the tank inside a building where fumes may reach an open flame or spark. Allow the engine to cool before storing in any enclosure.

TILLER

- Clean entire tiller (See “CLEANING” in the Maintenance section of this manual).
- Inspect and replace belts, if necessary (See belt replacement instructions in the Service and Adjustments section of this manual).
- Lubricate as shown in the Maintenance section of this manual.
- Be sure that all nuts, bolts and screws are securely fastened. Inspect moving parts for damage, breakage and wear. Replace if necessary.
- Touch up all rusted or chipped paint surfaces; sand lightly before painting.

ENGINE

FUEL SYSTEM

IMPORTANT: IT IS IMPORTANT TO PREVENT GUM DEPOSITS FROM FORMING IN ESSENTIAL FUEL SYSTEM PARTS SUCH AS THE CARBURETOR, FUEL FILTER, FUEL HOSE, OR TANK DURING STORAGE. ALSO, EXPERIENCE INDICATES THAT ALCOHOL BLENDED FUELS (CALLED GASOHOL OR USING ETHANOL OR METHANOL) CAN ATTRACT MOISTURE WHICH LEADS TO SEPARATION AND FORMATION OF ACIDS DURING STORAGE. ACIDIC GAS CAN DAMAGE THE FUEL SYSTEM OF AN ENGINE WHILE IN STORAGE.

- Drain the fuel tank.
- Start the engine and let it run until the fuel lines and carburetor are empty.
- Never use engine or carburetor cleaner products in the fuel tank or permanent.

NOTE: Fuel stabilizer is an acceptable alternative in minimizing the formation of fuel gum deposits during storage. Add stabilizer to gasoline in fuel tank or storage container. Always follow the mix ratio found on stabilizer container. Run engine at least 10 minutes after adding stabilizer to allow the stabilizer to reach the carburetor. Do not drain the gas tank and carburetor if using fuel stabilizer.

ENGINE OIL

Drain oil (with engine warm) and replace with clean oil. (See “ENGINE” in the Maintenance section of this manual).

CYLINDER(S)

- Remove spark plug.
- Pour 1 ounce (29 ml) of oil through spark plug hole into cylinder.
- Pull starter handle slowly several times to distribute oil.
- Replace with new spark plug.

OTHER

- Do not store gasoline from one season to another.
- Replace your gasoline can if your can starts to rust. Rust and/or dirt in your gasoline will cause problems.
- If possible, store your unit indoors and cover it to give protection from dust and dirt.
- Cover your unit with a suitable protective cover that does not retain moisture. Do not use plastic. Plastic cannot breathe which allows condensation to form and will cause your unit to rust.

IMPORTANT: NEVER COVER TILLER WHILE ENGINE AND EXHAUST AREAS ARE STILL WARM.

TROUBLESHOOTING POINTS

PROBLEM	CAUSE	CORRECTION
Will not start	<ol style="list-style-type: none"> 1. Out of fuel. 2. Engine not "CHOKED" properly. 3. Engine flooded. 4. Dirty air cleaner. 5. Water in fuel. 6. Clogged fuel tank. 7. Loose spark plug wire. 8. Bad spark plug or improper gap. 9. Carburetor out of adjustment. 	<ol style="list-style-type: none"> 1. Fill fuel tank. 2. See "TO START ENGINE" in the Operation section. 3. Wait several minutes before attempting to start. 4. Clean or replace air cleaner cartridge. 5. Drain fuel tank and carburetor, and refill tank with fresh line. 6. Remove fuel tank and clean. 7. Make sure spark plug wire is seated properly on plug. 8. Replace spark plug or adjust gap. 9. Make necessary adjustments.
Hard to start	<ol style="list-style-type: none"> 1. Throttle control not set properly. 2. Dirty air cleaner. 3. Bad spark plug or improper gap. 4. Stale or dirty fuel. 5. Loose spark plug wire. 6. Carburetor out of adjustment. 	<ol style="list-style-type: none"> 1. Place throttle control in "FAST" position. 2. Clean or replace air cleaner cartridge. 3. Replace spark plug or adjust gap. 4. Drain fuel tank and refill with fresh gasoline. 5. Make sure spark plug wire is seated properly on plug. 6. Make necessary adjustments.
Loss of power	<ol style="list-style-type: none"> 1. Engine is overloaded. 2. Dirty air cleaner. 3. Low oil level/dirty oil. 4. Faulty spark plug. 5. Oil in fuel. 6. Stale or dirty fuel. 7. Water in fuel. 8. Clogged fuel tank. 9. Spark plug wire loose. 10. Dirty engine air screen. 11. Dirty/clogged muffler. 12. Carburetor out of adjustment. 13. Poor compression. 	<ol style="list-style-type: none"> 1. Set depth stake and wheels for shallower tilling. 2. Clean or replace air cleaner cartridge. 3. Check oil level/change oil. 4. Clean and regap or change spark plug. 5. Drain and clean fuel tank and refill, and clean carburetor. 6. Drain fuel tank and refill with fresh gasoline. 7. Drain fuel tank and carburetor, and refill tank with fresh gasoline. 8. Remove fuel tank and clean. 9. Connect and tighten spark plug wire. 10. Clean engine air screen. 11. Clean/replace muffler. 12. Make necessary adjustments. 13. Contact an authorized service center/department.
Engine overheats	<ol style="list-style-type: none"> 1. Low oil level/dirty oil. 2. Dirty engine air screen. 3. Dirty engine. 4. Partially plugged muffler. 5. Improper carburetor adjustment. 	<ol style="list-style-type: none"> 1. Check oil level/change oil. 2. Clean engine air screen. 3. Clean cylinder fins, air screen, muffler area. 4. Remove and clean muffler. 5. Adjust carburetor to richer position.
Excessive bounce/ difficult handling	<ol style="list-style-type: none"> 1. Ground too dry and hard. 2. Wheels and depth stake incorrectly adjusted. 	<ol style="list-style-type: none"> 1. Moisten ground or wait for more favorable soil conditions. 2. Adjust wheels and depth stake.
Soil balls up or clumps	<ol style="list-style-type: none"> 1. Ground too wet. 	<ol style="list-style-type: none"> 1. Wait for more favorable soil conditions.
Engine runs but tiller won't move	<ol style="list-style-type: none"> 1. Tine control is not engaged. 2. V-belt not correctly adjusted. 3. V-belt is off pulley(s). 	<ol style="list-style-type: none"> 1. Engage tine control. 2. Inspect/adjust V-belt. 3. Inspect V-belt.
Engine runs but labors when tilling	<ol style="list-style-type: none"> 1. Tilling too deep. 2. Throttle control not properly adjusted. 3. Carburetor out of adjustment. 	<ol style="list-style-type: none"> 1. Set depth stake for shallower tilling. 2. Check throttle control setting. 3. Make necessary adjustments.

REPAIR PARTS

TILLER - - MODEL NUMBER 944.621534

HANDLE ASSEMBLY

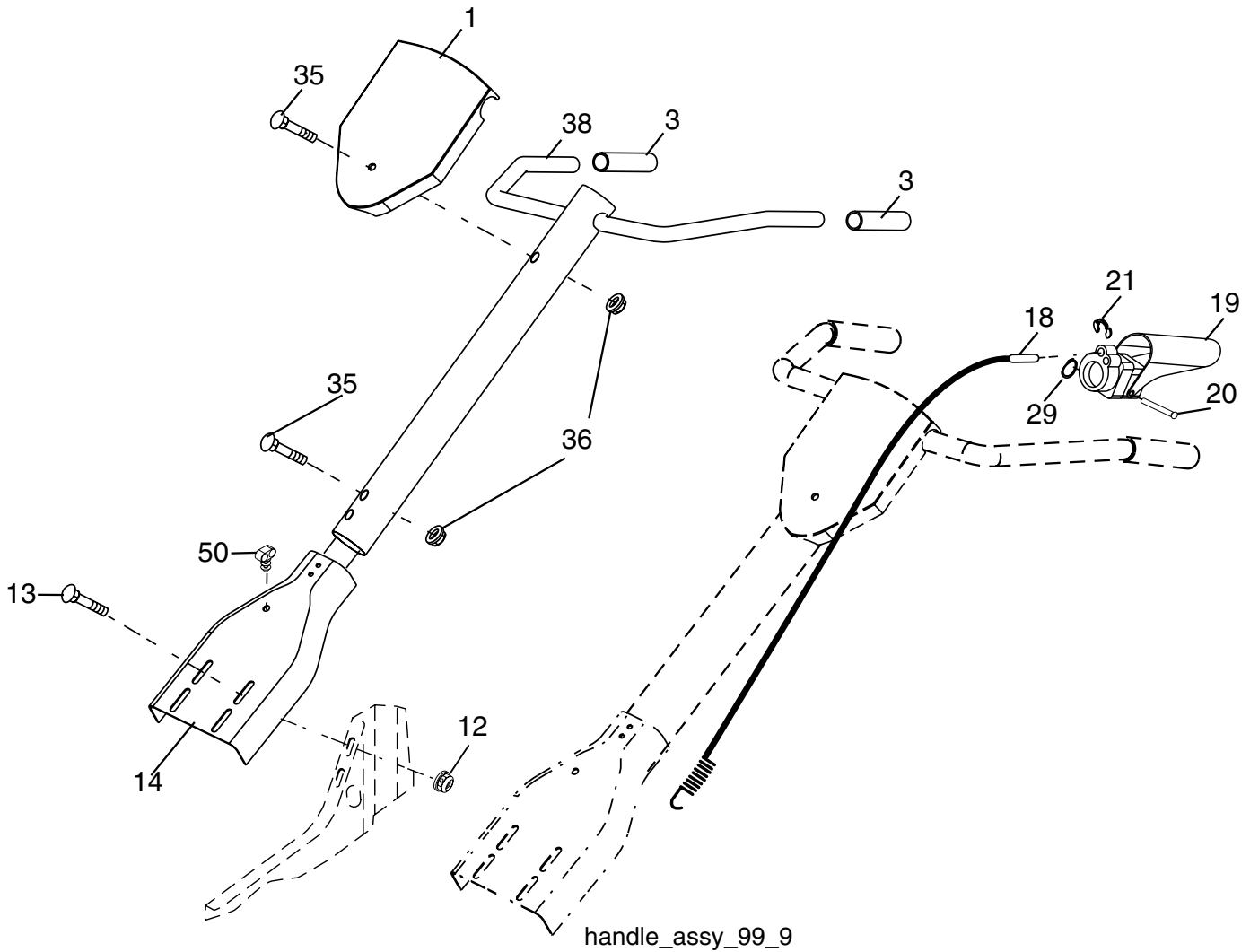

KEY NO.	PART NO.	DESCRIPTION
1	137118X021	Panel, Control
3	9266R	Grip, Handle
12	98000129	Nut, Flange
13	STD533107	Bolt, Carriage 5/16-18 x 3/4
14	181476	Assembly, Panel and Tube
18	3066J	Cable, Tine Control
19	151229	Lever, Control, Tine
20	154805	Pin, Pivot

KEY NO.	PART NO.	DESCRIPTION
21	12000027	Ring, Clip
29	12000059	Retainer, Ring
35	72010520	Bolt 5/16-18 x 2-1/2
36	73970500	Locknut, Flange 5/16-18 Unc
38	152094	Assembly, Handle Column
50	181580	Clip Dual

NOTE: All component dimensions given in U.S. inches.
1 inch = 25.4 mm

REPAIR PARTS

TILLER - - MODEL NUMBER 944.621534

BELT GUARD AND PULLEY ASSEMBLY

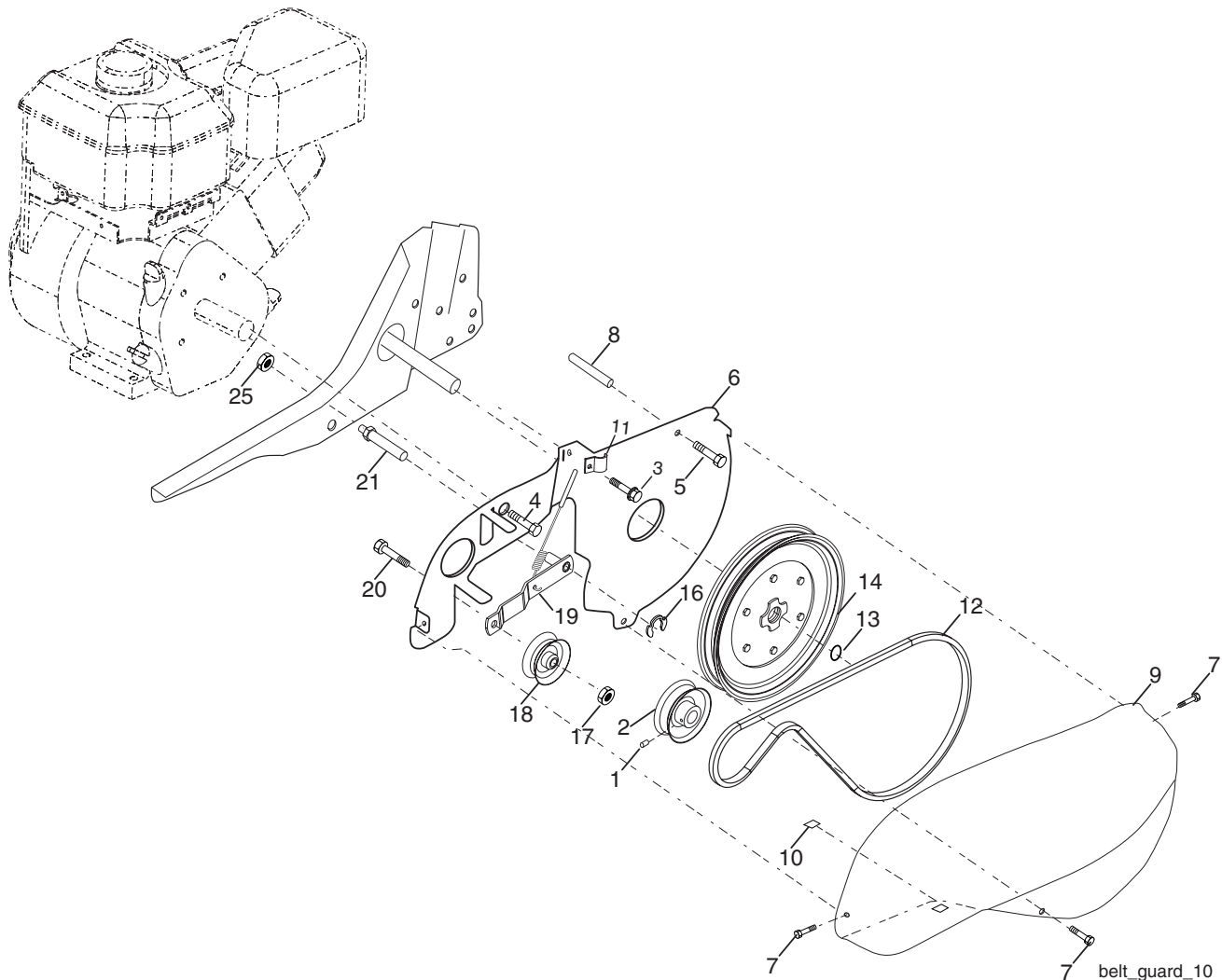

KEY NO.	PART NO.	DESCRIPTION
1	23230506	Screw Set 5/16-18 x 3/8 Patch
2	130812	Sheave, Engine
3	86777	Screw Hex Wsh SLT
4	74610812	Bolt, Hex Head 1/2-20 x 3/4
5	17490440	Bolt, Thd Roller 1/4-20 x 2-1/2
6	174898	Shield, Inner Belt Guard
7	170488	Screw Hex Wsh
8	139155	Spacer Split .523 x .718 x 2.0
9	165768X558	Guard, Belt
10	109227X	Pad, Idler
11	9484R	Clip, Cable
12	9180R	V-Belt

KEY NO.	PART NO.	DESCRIPTION
13	12000028	Ring, Retainer
14	151223	Sheave, Transmisison
16	12000036	Ring, Klip
17	STD541237	Nut, Hex, Jam 3/8-16
18	161806	Pulley, Idler
19	175377	Arm, Idler
20	STD523712	Bolt, Hex Head 3/8-16 x 1-1/4
21	106968X	Shaft, Idler Arm
25	73350500	Nut, Hex, Jam 5/16-18

NOTE: All component dimensions given in U.S. inches.
1 inch = 25.4 mm

REPAIR PARTS

TILLER - - MODEL NUMBER 944.621534

WHEEL AND DEPTH STAKE ASSEMBLY

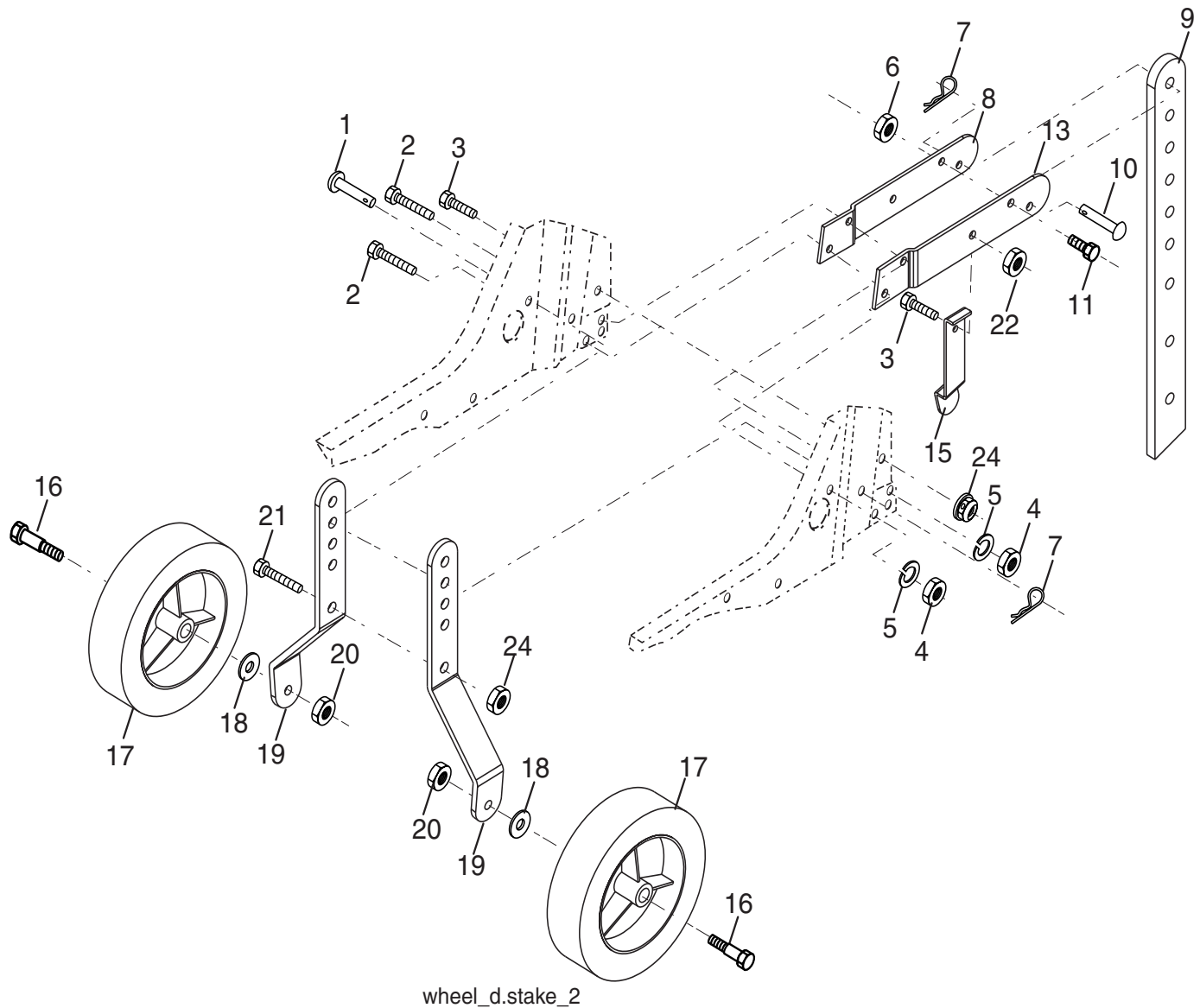

KEY NO.	PART NO.	DESCRIPTION
1	9194R	Pin, Clevis
2	74760520	Bolt, Hex Head 5/16-18 x 1-1/4
3	STD523107	Bolt, Hex Head 5/16-18 x 3/4
4	STD541031	Nut, Hex 5/16-18
5	STD551131	Washer, Lock 5/16
6	STD541437	Locknut, w/washer 3/8-16
7	4921H	Clip, Hairpin
8	1952J	Support, Depth Stake, R.H.
9	122233X	Stake, Depth
10	326J	Pin, Clevis
11	74780628	Bolt, Hex 3/8-16 x 1-3/4
13	1951J	Support, Depth Stake, L.H.

KEY NO.	PART NO.	DESCRIPTION
15	5388J	Spring, Stake
16	121117X	Bolt, Shoulder
17	9188R	Wheel
18	STD551037	Washer 13/32 x 13/16 x 11 Gauge
19	9190R	Bracket, Wheel
20	STD541437	Locknut, Crown 3/8-16
21	74760516	Bolt, Hex Head 5/16-18 x 1
22	STD541431	Locknut, w/insert 5/16-18
24	73970500	Nut Lock Hex Flange

NOTE: All component dimensions given in U.S. inches.
1 inch = 25.4 mm

REPAIR PARTS

TILLER - - MODEL NUMBER 944.621534

TINE ASSEMBLY

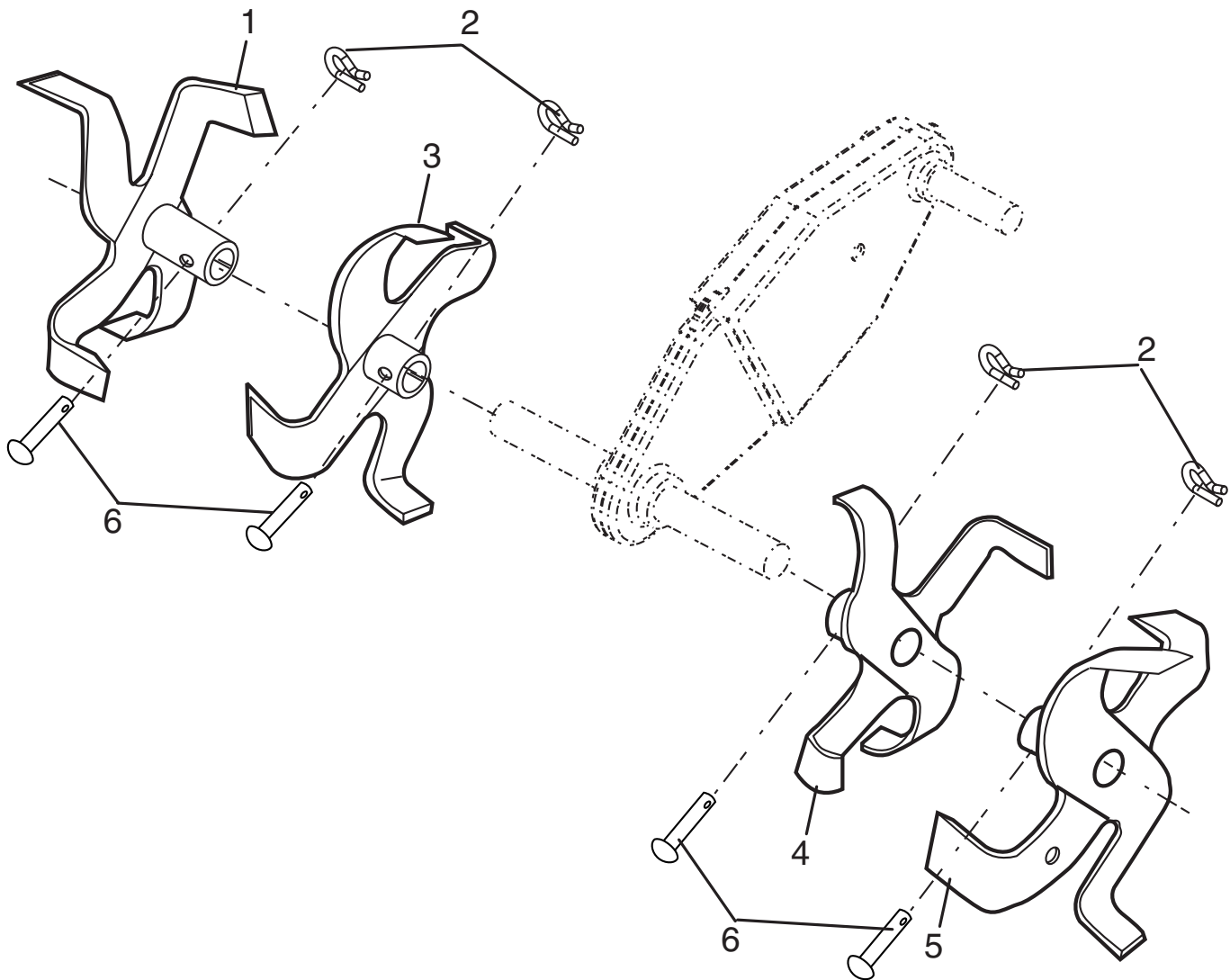

tine_ipb_3

KEY NO.	PART NO.	DESCRIPTION
1	156926	Tine, Outer, R.H.
2	3146R	Retainer, Spring Zinc
3	156924	Tine, Inner, R.H.

KEY NO.	PART NO.	DESCRIPTION
4	156923	Tine, Inner, L.H.
5	156925	Tine, Outer, L.H.
6	4929H	Pin, Clevis

REPAIR PARTS

TILLER - - MODEL NUMBER 944.621534

TRANSMISSION

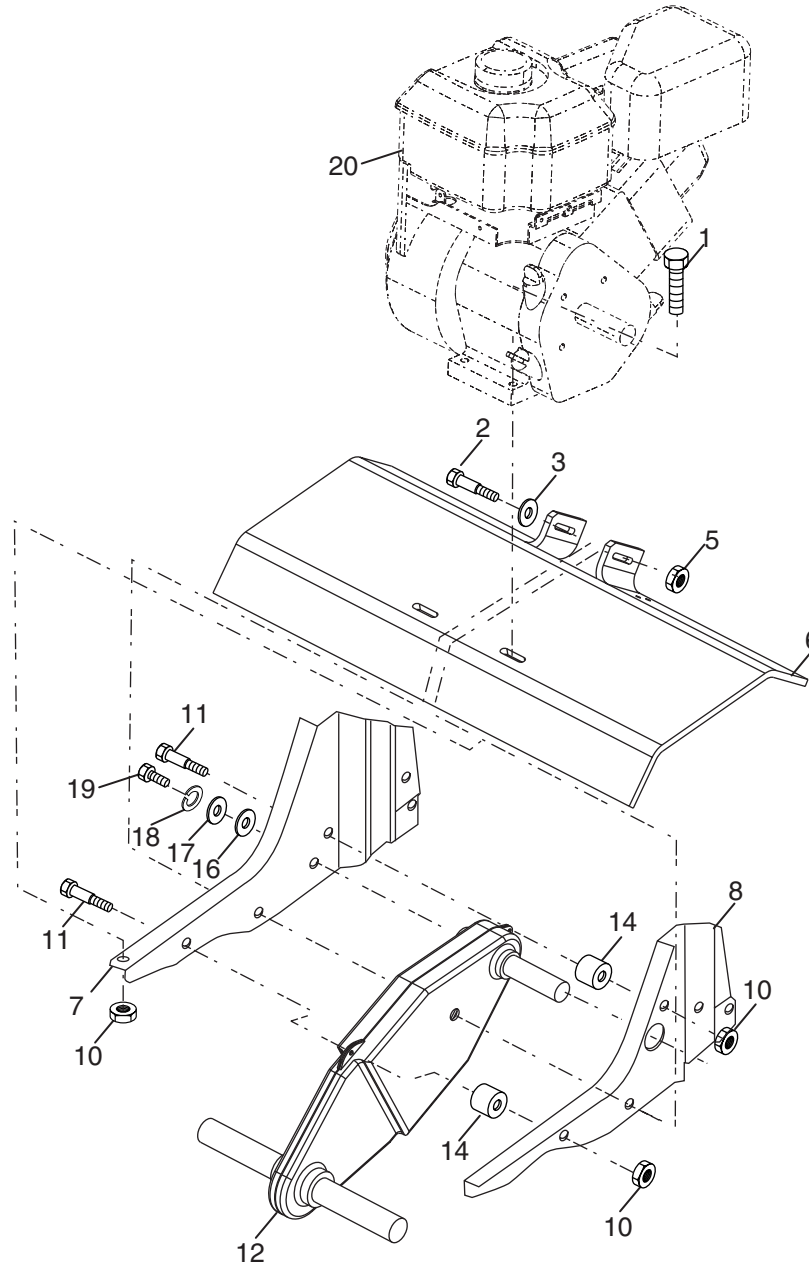

transmission_12

KEY NO.	PART NO.	DESCRIPTION
1	74760524	Bolt, Hex 5/16-18 x 1-1/2 Gr. 2
2	STD523732	Bolt, Fin, Hex 3/8-16 x 3-1/4
3	STD551037	Washer 13/32 x 13/16 x 11
5	STD541437	Locknut, w/washer 3/8-16
6	9056R558	Shield, Tine
7	188195	Bracket, Engine, R.H.
8	165834	Bracket, Engine, L.H.
10	73970500	Nut, Lock Hex Flg.
11	187912	Bolt Shoulder 5/16-18 unc x 2.5
12	176112	Transmission

KEY NO.	PART NO.	DESCRIPTION
14	9173R	Spacer, Split
16	19091412	Washer 9/32 x 7/8 x 12 Ga.
17	19092016	Washer 9/32 x 1-1/4 x 16 Ga.
18	STD551125	Washer, Lock 1/4
19	74610412	Bolt, Hex 1/4-28 x 3/4 Gr. 5
20	-----	Engine (See Breakdown) Briggs Model 126302-0206-E1

NOTE: All component dimensions given in U.S. inches.
1 inch = 25.4 mm

REPAIR PARTS

TILLER - - MODEL NUMBER 944.621534

DECALS

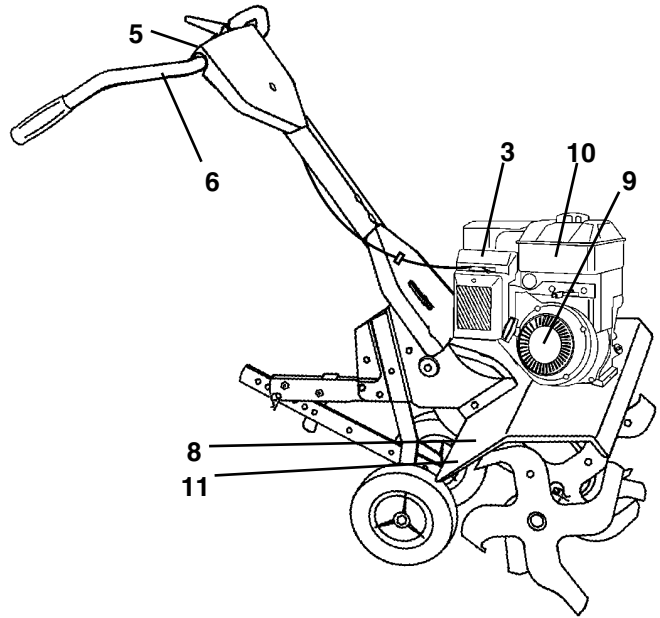
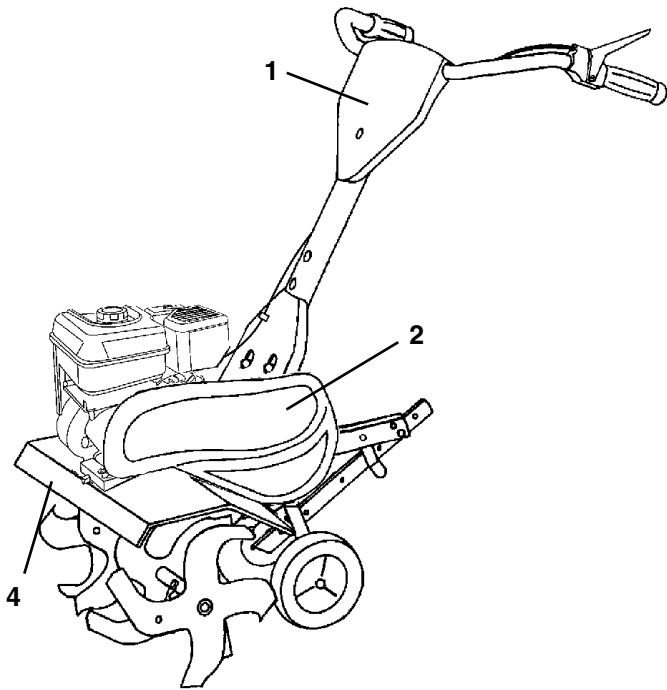

KEY NO.	PART NO.	DESCRIPTION
1	166217	Decal, Logo Control Panel
2	192380	Decal, Logo Belt Guard
3	176783	Decal, Engine Oper
4	190805	Decal, Tire Shield
5	137283	Decal, Cntrl Pnl Inst.
6	110614X	Decal, Hand Placement
8	162384	Decal, Tine Shield Warning
9	171078	Decal, Rewind/Intek
10	167156	Decal, B&S Intek
11	120076X	Decal, Warning, Rotating Tines
--	192373	Manual, Owner's (English)
--	192374	Manual, Owner's (French)

REPAIR PARTS

TILLER - - MODEL NUMBER 944.621534

ENGINE, BRIGGS & STRATTON - - MODEL NUMBER 126302, TYPE NO. 0206-E1

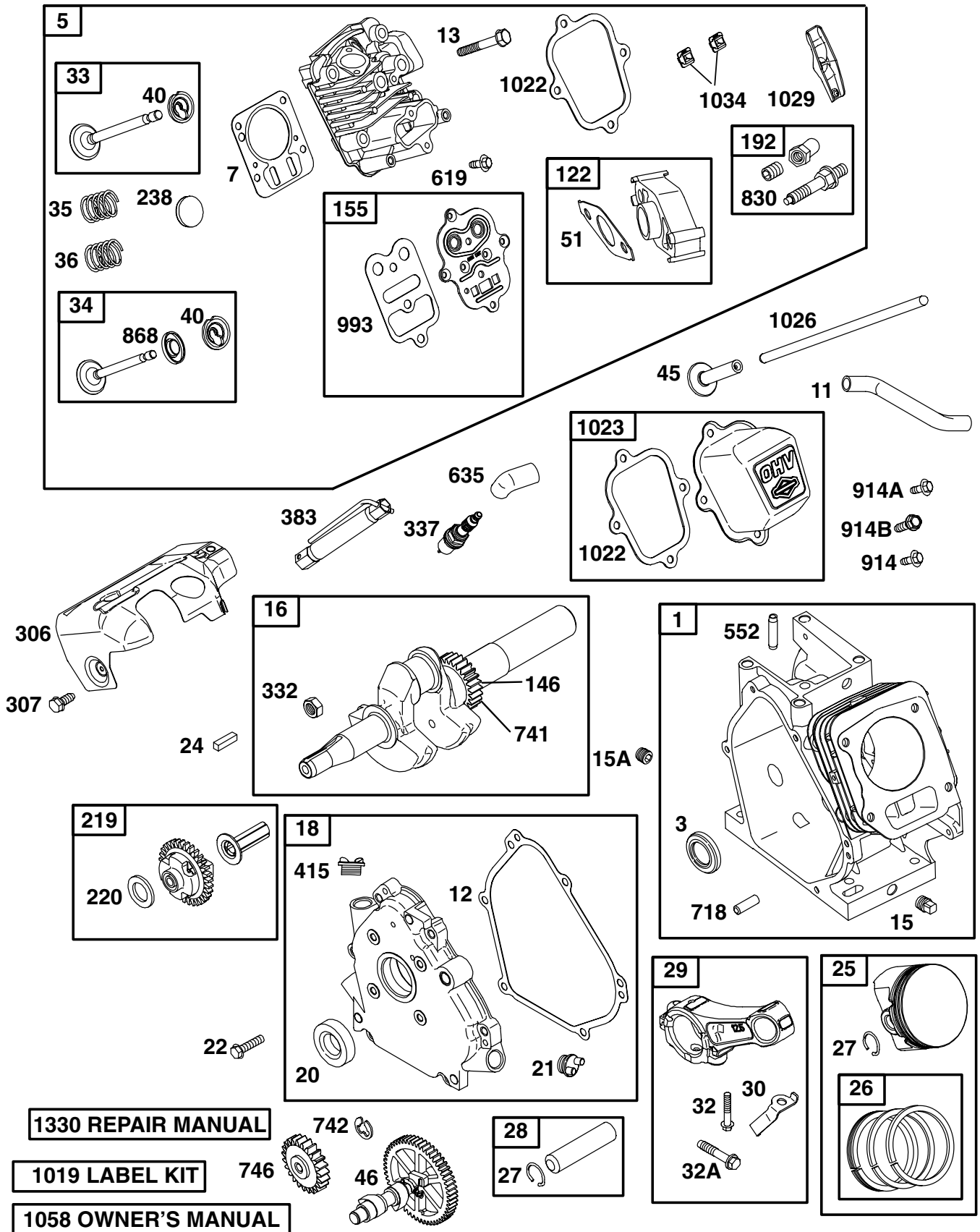

REPAIR PARTS

TILLER - - MODEL NUMBER 944.621534

ENGINE, BRIGGS & STRATTON - - MODEL NUMBER 126302, TYPE NO. 0206-E1

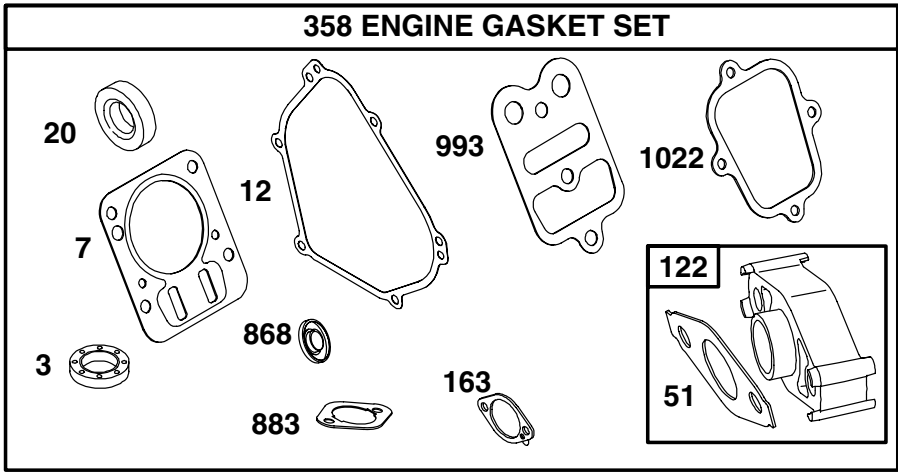
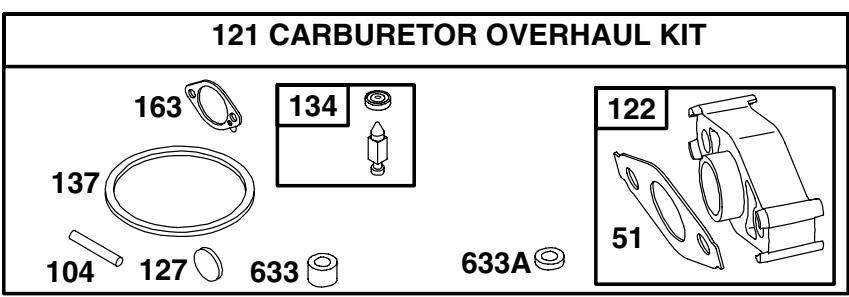
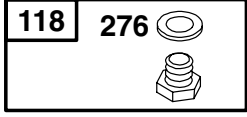
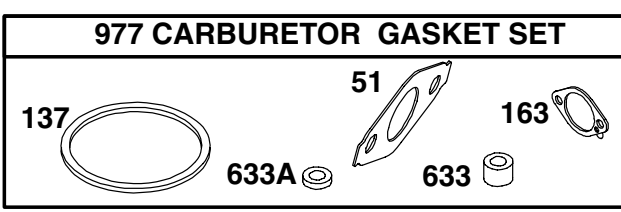
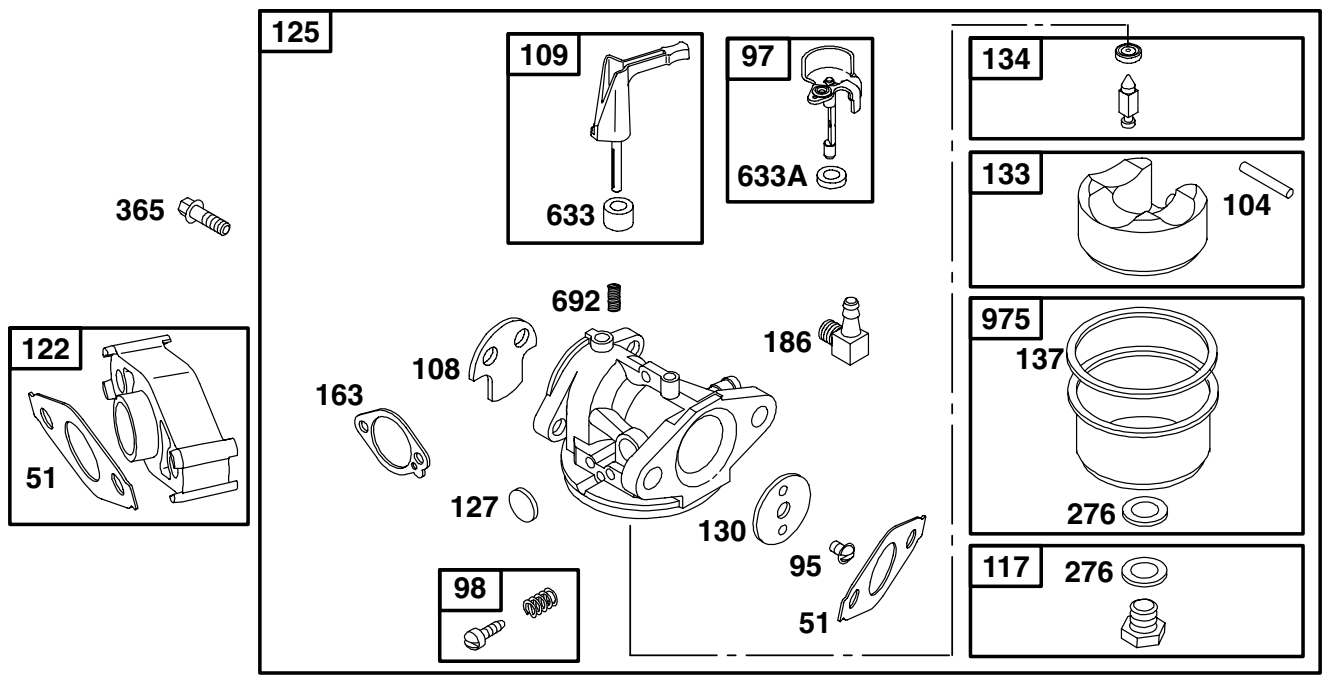

REPAIR PARTS

TILLER - - MODEL NUMBER 944.621534

ENGINE, BRIGGS & STRATTON - - MODEL NUMBER 126302, TYPE NO. 0206-E1

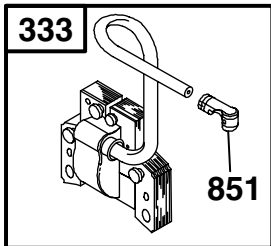
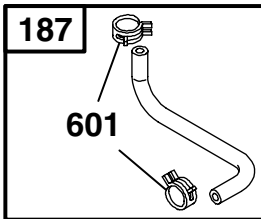
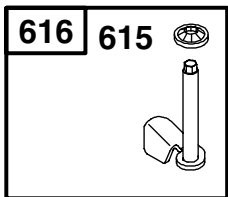
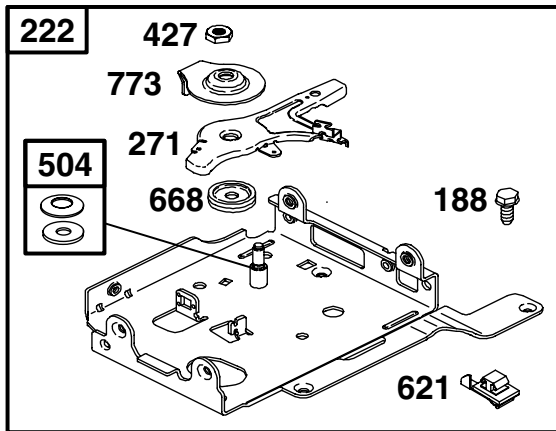
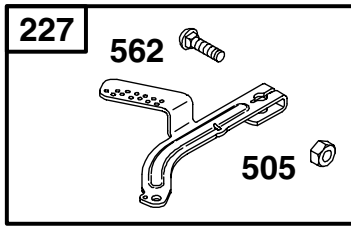

334

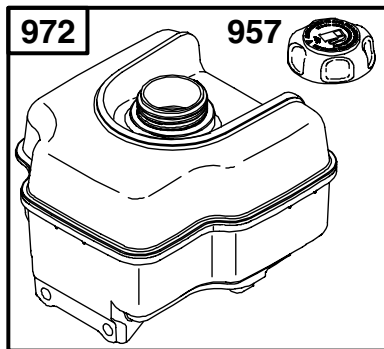

190

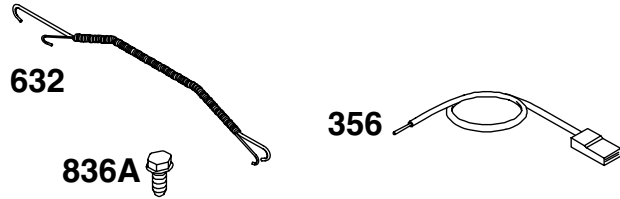
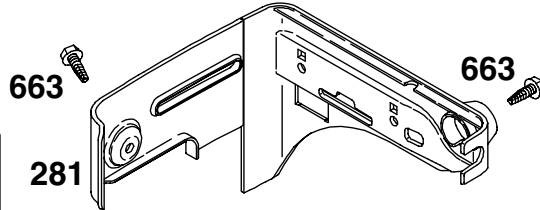

836A

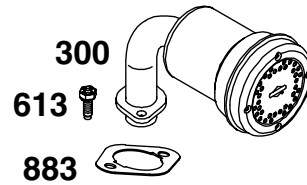
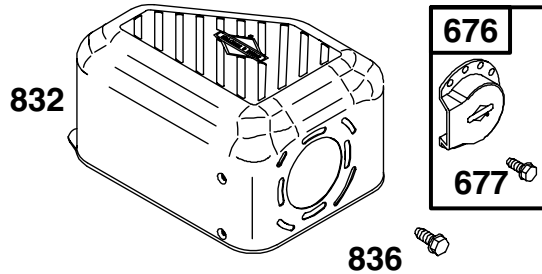

425

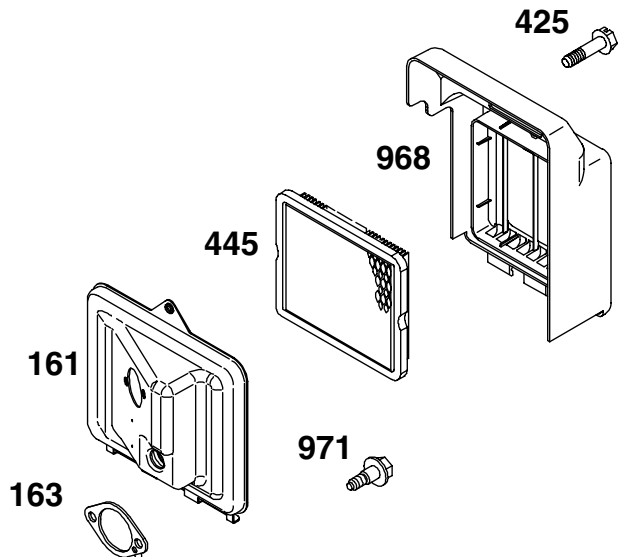

REPAIR PARTS

TILLER - - MODEL NUMBER 944.621534

ENGINE, BRIGGS & STRATTON - - MODEL NUMBER 126302, TYPE NO. 0206-E1

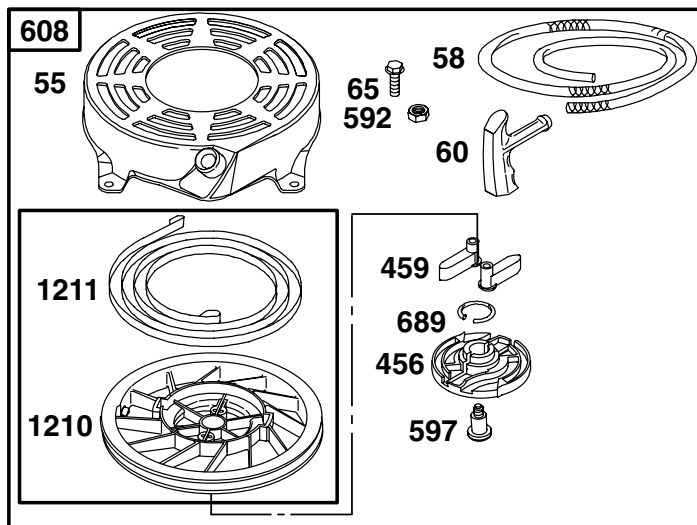

1036 EMISSIONS LABEL

1329 REPLACEMENT ENGINE

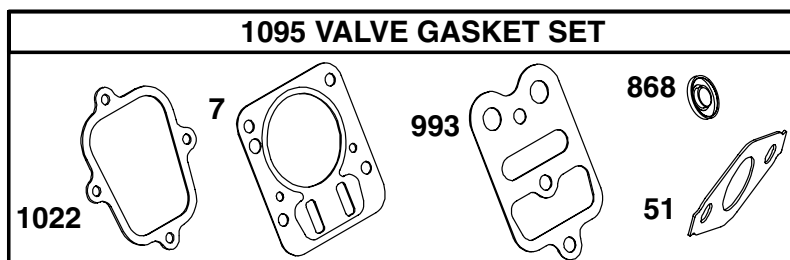
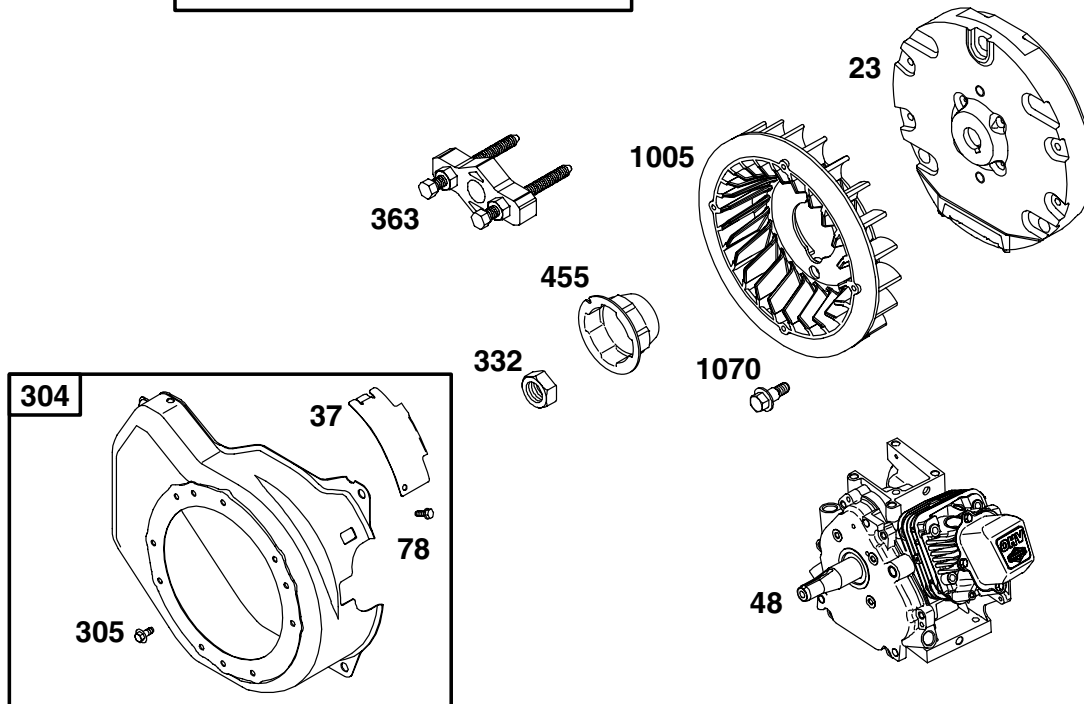

REPAIR PARTS

TILLER - - MODEL NUMBER 944.621534

ENGINE, BRIGGS & STRATTON - - MODEL NUMBER 126302, TYPE NO. 0206-E1

KEY NO.	PART NO.	DESCRIPTION	KEY NO.	PART NO.	DESCRIPTION
1	699510	Cylinder Assembly	155	698214	Plate-Cylinder Head
3	299819	• Seal-Oil (Magneto Side)	161	699207	Base-Air Cleaner
5	699486	Head-Cylinder	163	696024	•Ø‡ Gasket-Air Cleaner
7	698210	•+ Gasket-Cylinder Head	186	692317	Connector-Hose
11	692600	Tube-Breather	187	693401	Line-Fuel (Molded)
12	699485	• Gasket-Crankcase	188	699479	Screw (Control Bracket)
13	699482	Screw (Cylinder Head)	190	699220	Screw (Fuel Tank)
15	691686	Plug-Oil Drain	192	694543	Adjuster-Rocker Arm
15A	691682	Plug-Oil Drain	209	691278	Spring-Governor
16	699445	Crankshaft	209A	692571	Spring-Governor
18	699696	Cover-Crankcase	219	693578	Gear-Governor
20	692550	• Seal-Oil (PTO Side)	220	691724	Washer (Governor Gear)
21	281658	Cap-Oil Fill	222	699589	Bracket-Control
22	699478	Screw (Engine Sump)	227	692573	Control Lever-Governor
23	699488	Flywheel	238	691300	Cap-Valve
24	222698	Key-Flywheel	271	694256	Lever-Control
25	690021	Piston Assembly (Standard)	276	271716	Sealing Washer
	694168	Piston Assembly (.020" Oversize)	281	699639	Panel-Control
26	499631	Ring Set-Piston (Standard)	300	693593	Muffler
	692786	Ring Set-Piston (.020" Oversize)	304	699598	Housing-Blower
27	691866	Lock-Piston Pin	305	699480	Screw (Blower Housing)
28	499423	Pin-Piston	306	693610	Shield-Cylinder
29	690124	Rod-Connecting	307	699483	Screw (Cylinder Shield)
30	692562	Dipper-Connecting Rod	332	699359	Nut (Flywheel)
32	691664	Screw (Connecting Rod)	333	695711	Armature-Magneto
32A	695759	Screw (Connecting Rod)	334	699477	Screw (Armature Magneto)
33	499642	Valve-Exhaust	337	491055	Spark Plug
34	499641	Valve-Intake	356	692390	Wire-Stop
35	691304	Spring-Valve (Intake)	358	699638	Gasket Set-Engine
36	691304	Spring-Valve (Exhaust)	363	19069	Flywheel Puller
37	699661	Guard-Flywheel	365	692568	Screw (Carburetor)
40	692194	Retainer-Valve	383	19374	Wrench-Spark Plug
45	690977	Tappet-Valve	415	693463	Plug
46	693404	Camshaft	425	692583	Screw (Air Cleaner Cover)
48	699582	Short Block	427	694255	Nut (Control Bracket)
51	692555	•Ø‡+ Gasket-Intake	445	491588	Filter-Air Cleaner Cartridge
55	691421	Housing-Rewind Starter	455	692591	Cup-Flywheel
58	692259	Rope-Starter (Cut to Required Length)	456	692299	Plate-Pawl Friction
60	281434	Grip-Starter Rope	459	281505	Pawl-Ratchet
65	690837	Screw (Rewind Starter)	504	694254	Washer Set
78	699228	Screw (Flywheel Guard)	505	691251	Nut (Governor Control Lever)
95	691636	Screw (Throttle Valve)	552	692346	Bushing-Governor Crank
97	690024	Shaft-Throttle	562	691112	Bolt (Governor Control Lever)
98	398185	Kit-Idle Speed	592	690800	Nut (Rewind Starter)
104	691242	Ø Pin-Float Hinge	597	691696	Screw (Pawl Friction Plate)
108	692567	Valve-Choke	601	95162	Clamp-Hose
109	690023	Shaft-Choke	608	497680	Starter-Rewind
117	498978	Jet-Main (Standard)	613	699209	Screw (Muffler)
118	498975	Jet-Main (High Altitude)	615	692576	Retainer-Governor Shaft
121	696998	Kit-Carburetor Overhaul	616	692547	Crank-Governor
122	693749	• Ø Spacer-Carburetor	619	699230	Screw (Cylinder Head Plate)
125	696981	Carburetor	621	692310	Switch-Stop
127	691739	Ø Plug-Welch	632	693408	Spring/Link-Mechanical Governor
130	691181	Valve-Throttle			
133	398187	Float-Carburetor			
134	398188	Ø Kit-Needle/Seat			
137	693981	Ø‡ Gasket-Float Bowl			
146	690979	Key-Timing			

• Included in Engine Gasket Set, Key. No. 358
 Ø Included in Carburetor Overhaul Kit, Key. No. 121
 ‡ Included in Carburetor Gasket Set, Key. No. 977
 + Included in Valve Gasket Set, Key. No. 1095

NOTE: All component dimensions given in U.S. inches 1 inch = 25.4 mm

REPAIR PARTS

TILLER - - MODEL NUMBER 944.621534

ENGINE, BRIGGS & STRATTON - - MODEL NUMBER 126302, TYPE NO. 0206-E1

KEY NO.	PART NO.	DESCRIPTION
633	693867	Ø‡ Seal-Choke/Throttle Shaft
633A	691321	Ø‡ Seal-Throttle Shaft
635	692076	Boot-Spark Plug
663	699206	Screw (Control Panel)
668	694257	Spacer
676	393757	Deflector-Muffler
677	690661	Screw (Muffler Deflector)
689	691855	Spring-Friction
692	690572	Spring-Detent
718	690959	Pin-Locating
741	692565	Gear-Timing
742	692564	Retainer-E Ring
746	692566	Gear-Idler
773	694258	Retainer
830	694544	Stud (Rocker Arm)
832	693583	Guard-Muffler
836	699203	Screw (Muffler Guard)
836A	699632	Screw (Muffler Guard)
851	493880	Terminal-Spark Plug
868	692044	•+ Seal-Valve
883	691893	• Gasket-Exhaust
914	699481	Screw (Rocker Cover) (Bottom)
914A	692557	Screw (Rocker Cover) (Top)
914B	697551	Screw (Rocker Cover) (Center)
957	694261	Cap-Fuel Tank
968	692584	Cover-Air Cleaner
971	690370	Screw (Air Cleaner Base)
972	694260	Tank-Fuel
975	493640	Bowl-Float
977	697001	Gasket Set-Carburetor
993	694088	•+ Gasket-Cylinder Head Plate
1005	692592	Fan-Flywheel
1019	694851	Kit-Label
1022	691890	•+ Gasket-Rocker Cover
1023	499924	Cover-Rocker
1026	693517	Rod-Push
1029	691230	Arm-Rocker
1034	691343	Guide-Push Rod
1036	696766	Label-Emissions
1058	274781	Owner's Manual
1070	692590	Screw (Flywheel Fan)
1095	695289	Gasket Set-Valve
1210	498144	Assembly-Pulley/Spring (Pulley)
1211	498144	Assembly-Pulley/Spring (Spring)
1329	-- -- --	126312-0023 Replacement Engine (Transfer the Governor Spring and Exhaust)
1330	272147	Repair Manual

- Included in Engine Gasket Set, Key. No. 358
- Ø Included in Carburetor Overhaul Kit, Key. No. 121
- ‡ Included in Carburetor Gasket Set, Key. No. 977
- + Included in Valve Gasket Set, Key. No. 1095

NOTE: All component dimensions given in U.S. inches 1 inch = 25.4 mm

SERVICE NOTES

SERVICE NOTES

SERVICE NOTES

Get it fixed, at your home or ours!

Just Call:

1-800-4-MY-HOME[®]

(1-800-469-4663)

24 hours a day, 7 days a week

For the repair of major brand appliances **in your own home...**
no matter who made it, no matter who sold it!

For your nearest **Sears Parts and Service** location,
to bring in products like vacuums, lawn equipment and electronics.

For **Sears Parts & Service**, to order the replacement parts,
accessories and owner's manuals that you need to do-it-yourself.

www.sears.ca

To purchase or inquire about a Sears Maintenance Agreement, call:

1-800-361-6665

9 a.m. – 11 p.m. Mon. – Fri., EST, 9 a.m. – 4 p.m. Sat.

Pour service en français:

1-800-LE-FOYER^{MC}

(1-800-533-6937)

www.sears.ca



02488

® / TM Trademarks of Sears, Roebuck and Co. used under license by Sears Canada

MD Marque déposée / MC Marque de commerce de Sears, Roebuck and Co. utilisée en vertu d'une licence de Sears Canada