

SEARS

**OWNER'S
MANUAL**

**MODEL NO.
944.625930**

**Important:
Read and follow
all Safety Rules
and Instructions
Before Operating
This Equipment**

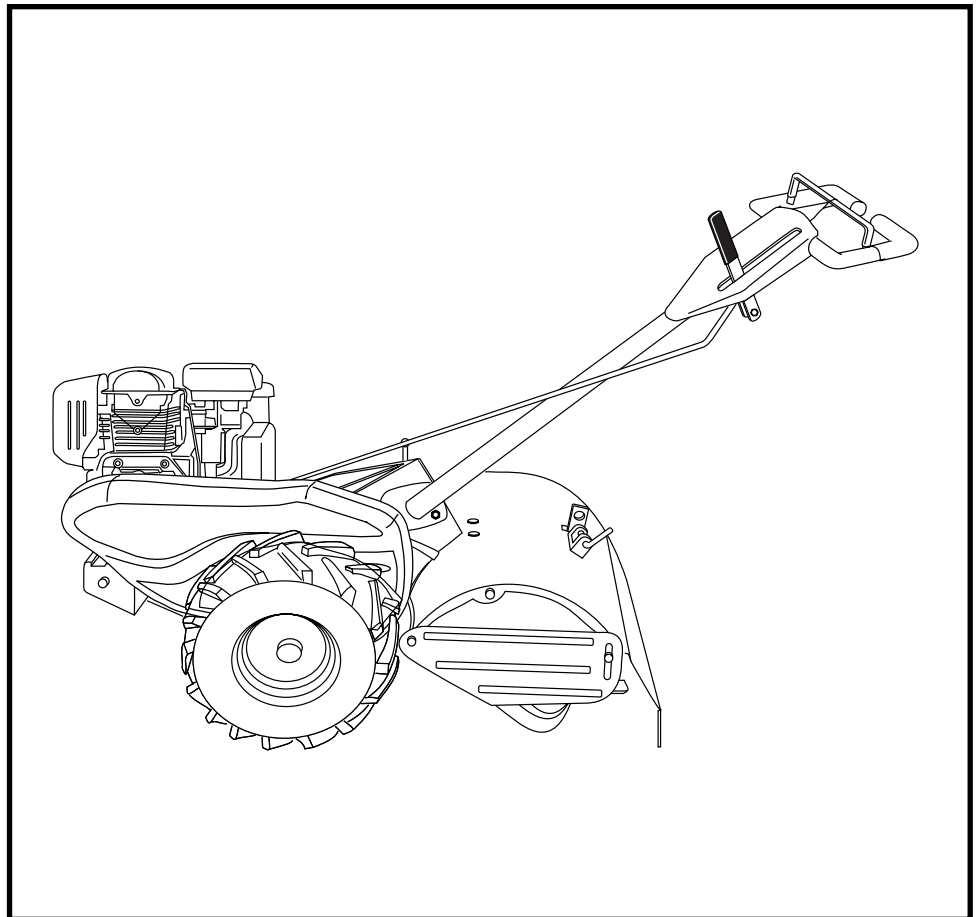

CRAFTSMAN®

**5.0 HP
17 INCH TINE WIDTH
REAR TINE TILLER WITH
COUNTER ROTATING TINES**

- **Assembly**
- **Operation**
- **Maintenance**
- **Service and Adjustments**
- **Repair Parts**

SAFETY RULES



SAFE OPERATION PRACTICES FOR WALK-BEHIND POWERED ROTARY TILLERS



TRAINING

- Read the Owner's Manual carefully. Be thoroughly familiar with the controls and the proper use of the equipment. Know how to stop the unit and disengage the controls quickly.
- Never allow children to operate the equipment. Never allow adults to operate the equipment without proper instruction.
- Keep the area of operation clear of all persons, particularly small children, and pets.

PREPARATION

- Thoroughly inspect the area where the equipment is to be used and remove all foreign objects.
- Disengage all clutches and shift into neutral before starting the engine (motor).
- Do not operate the equipment without wearing adequate outer garments. Wear footwear that will improve footing on slippery surfaces.
- Handle fuel with care; it is highly flammable.
- Use an approved fuel container.
- Never add fuel to a running engine or hot engine.
- Fill fuel tank outdoors with extreme care. Never fill fuel tank indoors.
- Replace gasoline cap securely and clean up spilled fuel before restarting.
- Use extension cords and receptacles as specified by the manufacturer for all units with electric drive motors or electric starting motors.
- Never attempt to make any adjustments while the engine (motor) is running (except where specifically recommended by manufacturer).

OPERATION

- Do not put hands or feet near or under rotating parts.
- Exercise extreme caution when operating on or crossing gravel drives, walks, or roads. Stay alert for hidden hazards or traffic. Do not carry passengers.
- After striking a foreign object, stop the engine (motor), remove the wire from the spark plug, thoroughly inspect the tiller for any damage, and repair the damage before restarting and operating the tiller.
- Exercise caution to avoid slipping or falling.
- If the unit should start to vibrate abnormally, stop the engine (motor) and check immediately for the cause. Vibration is generally a warning of trouble.
- Stop the engine (motor) when leaving the operating position.
- Take all possible precautions when leaving the machine unattended. Disengage the tines, shift into neutral, and stop the engine.
- Before cleaning, repairing, or inspecting, shut off the engine and make certain all moving parts have stopped. Disconnect the spark plug wire, and keep the wire away from the plug to prevent accidental starting. Disconnect the cord on electric motors.

- Do not run the engine indoors; exhaust fumes are dangerous.
- Never operate the tiller without proper guards, plates, or other safety protective devices in place.
- Keep children and pets away.
- Do not overload the machine capacity by attempting to till too deep at too fast a rate.
- Never operate the machine at high speeds on slippery surfaces. Look behind and use care when backing.
- Never allow bystanders near the unit.
- Use only attachments and accessories approved by the manufacturer of the tiller.
- Never operate the tiller without good visibility or light.
- Be careful when tilling in hard ground. The tines may catch in the ground and propel the tiller forward. If this occurs, let go of the handlebars and do not restrain the machine.

MAINTENANCE AND STORAGE

- Keep machine, attachments, and accessories in safe working condition.
- Check shear pins, engine mounting bolts, and other bolts at frequent intervals for proper tightness to be sure the equipment is in safe working condition.
- Never store the machine with fuel in the fuel tank inside a building where ignition sources are present, such as hot water and space heaters, clothes dryers, and the like. Allow the engine to cool before storing in any enclosure.
- Always refer to the operator's guide instructions for important details if the tiller is to be stored for an extended period.

- IMPORTANT -

CAUTIONS, IMPORTANTS, AND NOTES ARE A MEANS OF ATTRACTING ATTENTION TO IMPORTANT OR CRITICAL INFORMATION IN THIS MANUAL.

IMPORTANT: USED TO ALERT YOU THAT THERE IS A POSSIBILITY OF DAMAGING THIS EQUIPMENT.

NOTE: Gives essential information that will aid you to better understand, incorporate, or execute a particular set of instructions.



Look for this symbol to point out important safety precautions. It means CAUTION!!! BECOME ALERT!!! YOUR SAFETY IS INVOLVED.



CAUTION: Always disconnect spark plug wire and place wire where it cannot contact spark plug in order to prevent accidental starting when setting up, transporting, adjusting or making repairs.

PRODUCT SPECIFICATIONS

Gasoline Capacity:	2 Quarts (1,89L) Unleaded Regular
Oil (API-SF-SJ): (Capacity: 20 oz./0.6L)	SAE 30 (Above 40°F/4°C) SAE 5w-30/10W-30
Spark Plug : (Gap: .030"/0.76mm)	NGK BPR6ES

CONGRATULATIONS on your purchase of a Sears Tiller. It has been designed, engineered and manufactured to give you the best possible dependability and performance.

Should you experience any problems you cannot easily remedy, please contact your nearest authorized Sears Service Centre/Department. They have competent, well-trained technicians and the proper tools to service or repair this unit.

Please read and retain this manual. The instructions will enable you to assemble and maintain your tiller properly. Always observe the "SAFETY RULES".

CUSTOMER RESPONSIBILITIES

- Read and observe the safety rules.
- Follow a regular schedule in maintaining, caring for and using your tiller.
- Follow the instructions under the "Maintenance" and "Storage" sections of this Owner's Manual.

IMPORTANT: THIS UNIT IS EQUIPPED WITH AN INTERNAL COMBUSTION ENGINE AND SHOULD NOT BE USED ON OR NEAR ANY UNIMPROVED FOREST-COVERED, BRUSH-COVERED OR GRASS COVERED LAND UNLESS THE ENGINE'S EXHAUST SYSTEM IS EQUIPPED WITH A SPARK ARRESTER MEETING APPLICABLE LOCAL OR STATE LAWS (IF ANY). IF A SPARK ARRESTER IS USED, IT SHOULD BE MAINTAINED IN EFFECTIVE WORKING ORDER BY THE OPERATOR.

SEE YOUR SEARS AUTHORIZED SERVICE CENTRE/DEPARTMENT FOR SPARK ARRESTER. REFER TO THE REPAIR PARTS SECTION OF THIS MANUAL FOR PART NUMBER.

LIMITED TWO (2) YEAR WARRANTY ON CRAFTSMAN TILLER

For Two (2) years from date of purchase Sears Canada, Inc. will repair or replace at Sears option free of charge parts which are defective as a result of material or workmanship.

COMMERCIAL OR RENTAL USE:

Warranty on Tiller will be thirty (30) days from date of purchase if used for commercial or rental purposes.

This Warranty does **NOT** cover:

1. Pre-delivery set-up.
2. Expendable items which become worn during normal use, such as tines, spark plugs, air cleaners, shear pins, and belts.
3. Repairs necessary because of operator abuse or negligence, including the failure to operate and maintain the equipment according to the instructions contained in the Owner's Manual.
4. In Home Service

Warranty service is available by returning the Craftsman Tiller to the nearest Sears Service Centre/Department in Canada. This warranty applies only while this product is in use in Canada.

This warranty is in addition to any statutory warranty and does not exclude or limit legal rights you may have but shall run concurrently with applicable provincial legislation. Furthermore, some provinces do NOT allow limitation on how long an implied warranty will last so the above limitations may not apply to you.

SEARS CANADA, INC., TORONTO, ONTARIO M5B 2B8

TABLE OF CONTENTS

SAFETY RULES	2	MAINTENANCE SCHEDULE	12-13
CUSTOMER RESPONSIBILITIES	3	SERVICE & ADJUSTMENTS	14-16
PRODUCT SPECIFICATIONS	3	STORAGE	17
WARRANTY	3	TROUBLESHOOTING	18
ASSEMBLY	4-6	REPAIR PARTS-TILLER	19-25
OPERATION	7-11	REPAIR PARTS-ENGINE	26-30
MAINTENANCE SCHEDULE	12	SERVICE/PARTS ORDERING	BACK COVER

ASSEMBLY

Your new tiller has been assembled at the factory with exception of those parts left unassembled for shipping purposes. To ensure safe and proper operation of your tiller all parts and hardware you assemble must be tightened securely. Use the correct tools as necessary to insure proper tightness.

TOOLS REQUIRED FOR ASSEMBLY

A socket wrench set will make assembly easier. Standard wrench sizes are listed.

- (1) Utility knife
- (1) Wire cutter
- (1) Screwdriver
- (1) Tire pressure gauge
- (1) Pair of pliers
- (1) 9/16" wrench

OPERATOR'S POSITION (See Fig. 1)

When right or left hand is mentioned in this manual, it means when you are in the operating position (standing behind tiller handles).

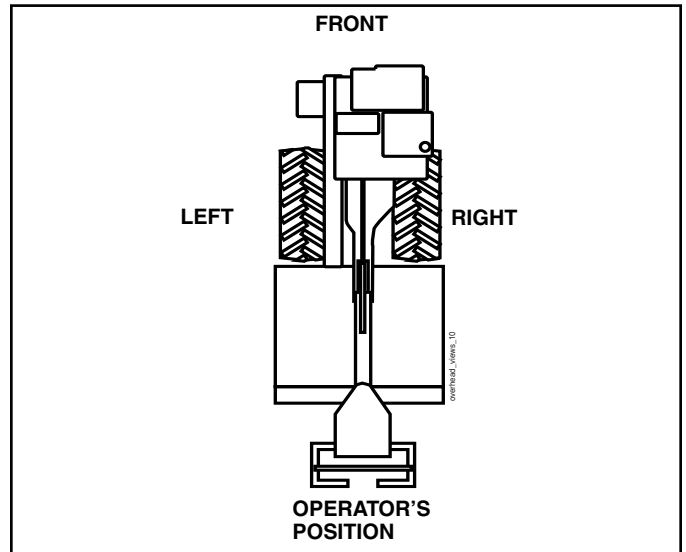
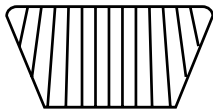
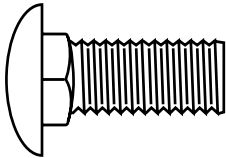

FIG. 1

CONTENTS OF HARDWARE PACK



(2) Handle Lock



(1) Carriage Bolt
3/8-16 UNC x 1 Gr. 5

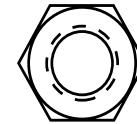

(1) Center Locknut
3/8-16 UNC

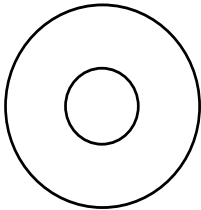

(1) Flat Washer 13/32 x 1 x 11 Ga.

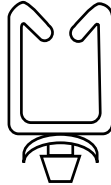

(1) Cable Clip

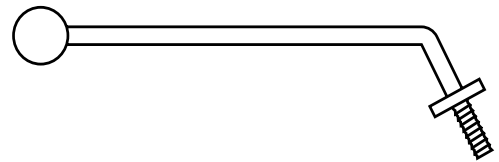

(1) Handle Lock Lever

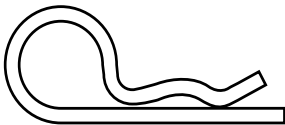

(1) Hairpin Clip

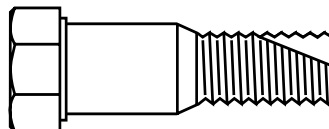

(1) Pivot Bolt
3/8-16 UNC Grade 5

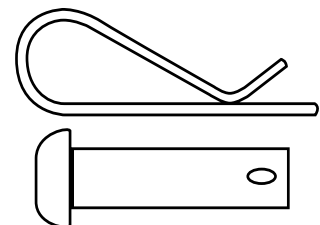

(2) Shear Pins & Clips

ASSEMBLY

UNPACKING CARTON (See Fig. 2)

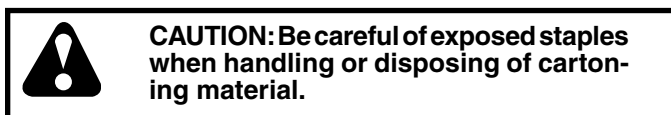

IMPORTANT: WHEN UNPACKING AND ASSEMBLING TILLER, BE CAREFUL NOT TO STRETCH OR KINK CABLES.

- While holding handle assembly, cut cable ties securing handle assembly to top frame. Let handle assembly rest on tiller.
- Remove top frame of carton.
- Slowly ease handle assembly up and place on top of carton.
- Cut down right hand front and right hand rear corners of carton, lay side carton wall down.
- Remove packing material from handle assembly.
- Separate shift rod from handle assembly.

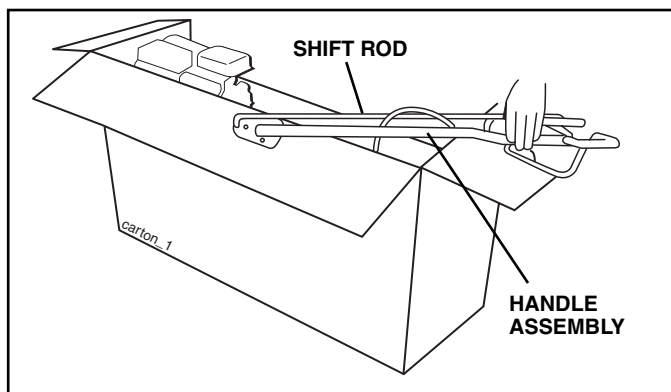

FIG. 2

INSTALL HANDLE (See Figs. 3, 4, and 5)

- Insert one handle lock (with teeth facing outward) in gearcase notch. (Apply grease on smooth side of handle lock to aid in keeping lock in place until handle assembly is lowered into position.)

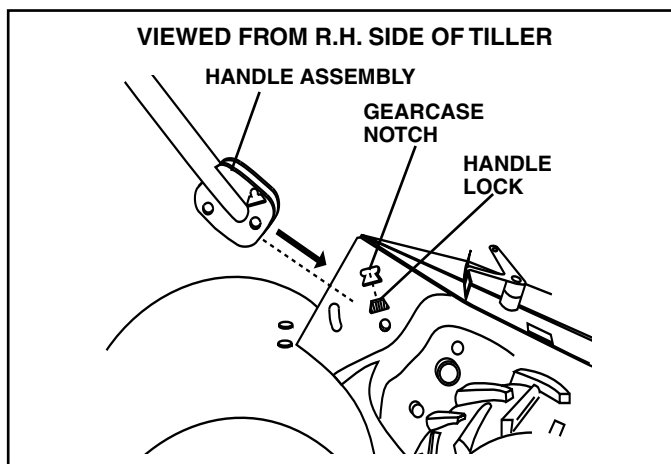

FIG. 3

- Grasp handle assembly. Hold in "up" position. Be sure handle lock remains in gearcase notch. Slide handle assembly into position.

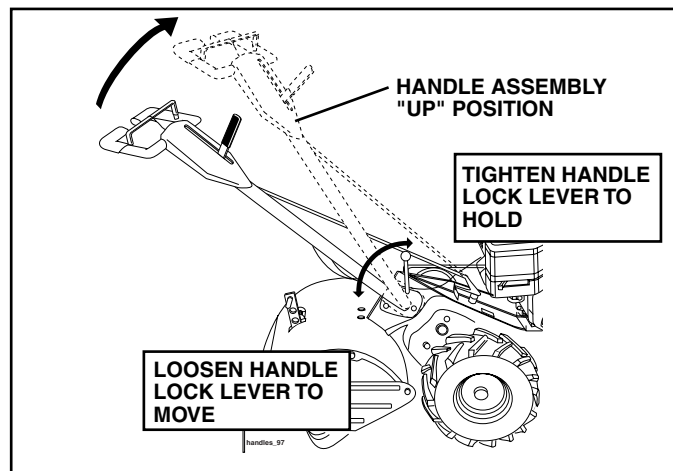

FIG. 4

- Rotate handle assembly down. Insert rear carriage bolt first, with head of bolt on L.H. side of tiller and loosely assemble locknut (See Fig. 5).
- Insert pivot bolt in front part of plate and tighten.
- Cut down remaining corners of carton and lay panels flat.
- Lower the handle assembly. Tighten nut on carriage bolt so handle moves with some resistance. This will allow for easier adjustment.
- Place flat washer on threaded end of handle lock lever.
- Insert handle lock lever through handle base and gearcase. Screw in handle lock lever just enough to hold lever in place.
- Insert second handle lock (with teeth inward) in the slot of the handle base (just inside of washer).
- Raise handle assembly to highest position and securely tighten handle lock lever by rotating clockwise. Leaving handle assembly in highest position will make it easier to connect shift rod.

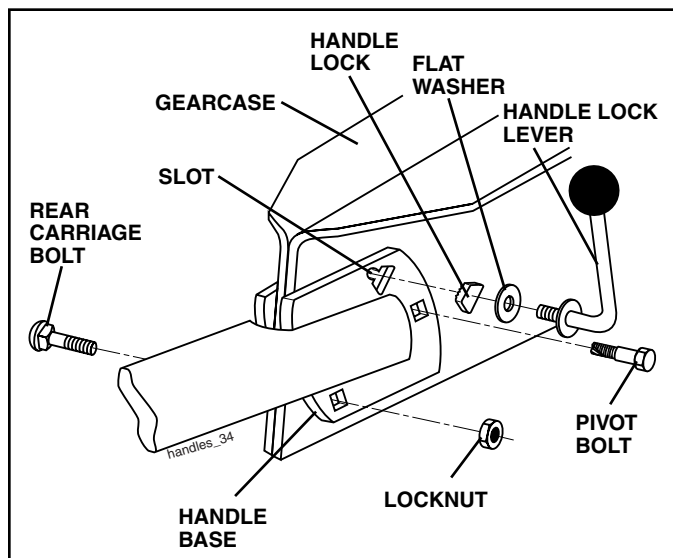

FIG. 5

ASSEMBLY

INSERT CABLE CLIP (See Fig. 6)

- Insert plastic cable clip into hole on the back of handle column. Push cables into clip.

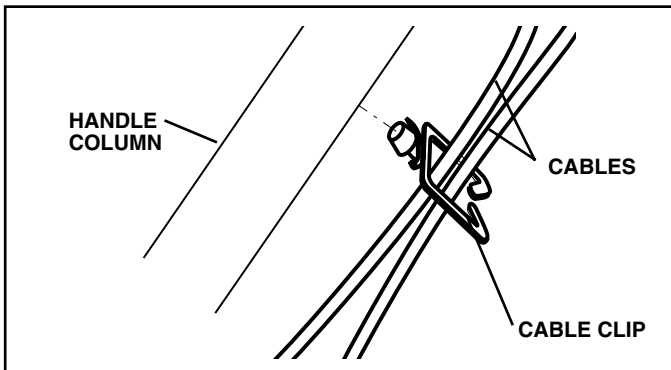

FIG. 6

CONNECT SHIFT ROD (See Fig. 7)

- Insert end of shift rod farthest from bend into hole of shift lever indicator.
- Insert hairpin clip through hole of shift rod to secure with bend of clip on right side.

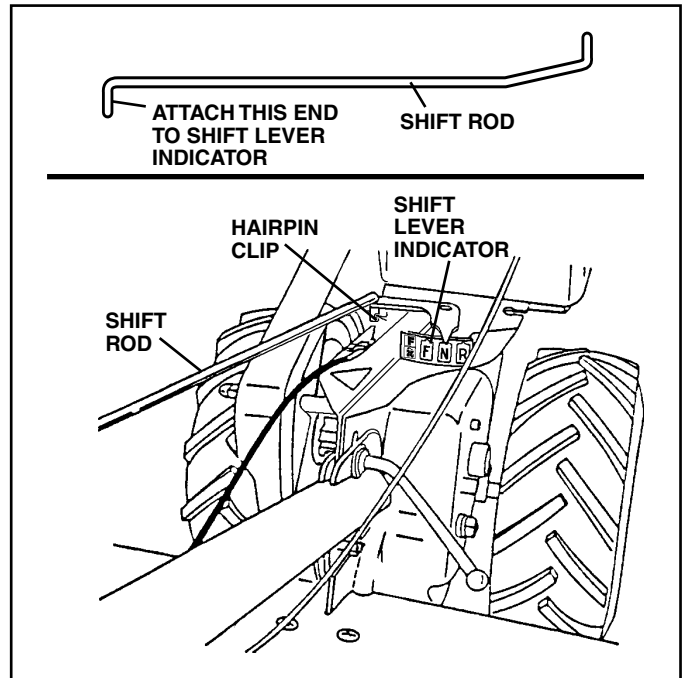

FIG. 7

REMOVE TILLER FROM CRATE

- Adjust handle assembly to lowest position. Be sure lock lever is tightened securely.
- Make sure shift lever indicator is in "N" (neutral) position (See Fig. 7)
- Tilt tiller forward by lifting handle. Separate cardboard cover from leveling shield.
- Rotate tiller handle to the right and pull tiller out of carton.

CHECK TIRE PRESSURE

The tires on your unit were overinflated at the factory for shipping purposes. Correct and equal tire pressure is important for best tilling performance.

- Reduce tire pressure to 20 PSI (1.4 kg/cm²)

HANDLE HEIGHT

- Handle height may be adjusted to better suit operator. (See "TO ADJUST HANDLE HEIGHT" in the Service and Adjustments section of this manual).

OPERATION

KNOW YOUR TILLER

READ THIS OWNER'S MANUAL AND SAFETY RULES BEFORE OPERATING YOUR TILLER.

Compare the illustrations with your tiller to familiarize yourself with the location of various controls and adjustments. Save this manual for future reference.

These symbols may appear on your Tiller or in literature supplied with the product. Learn and understand their meaning.

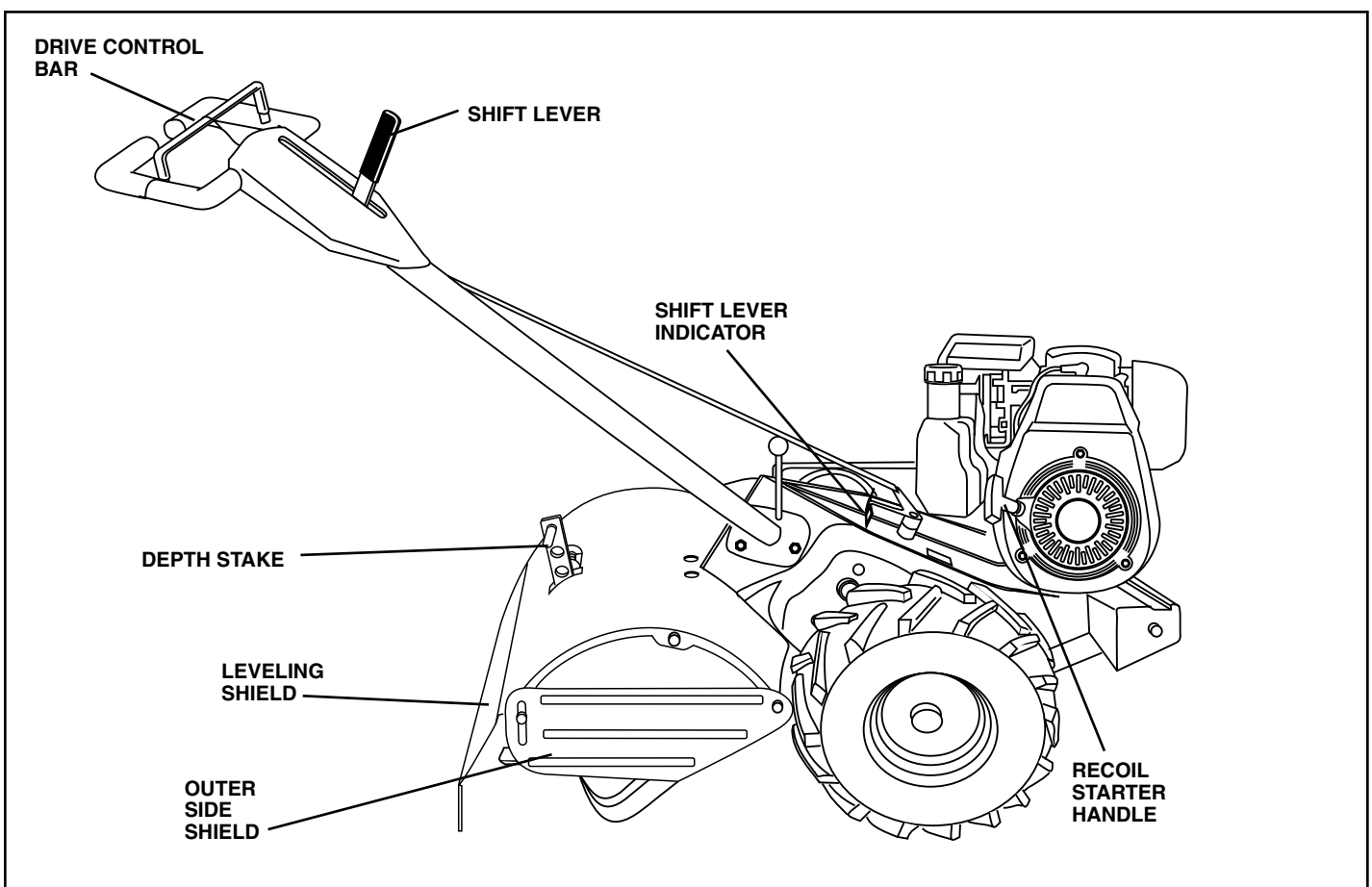
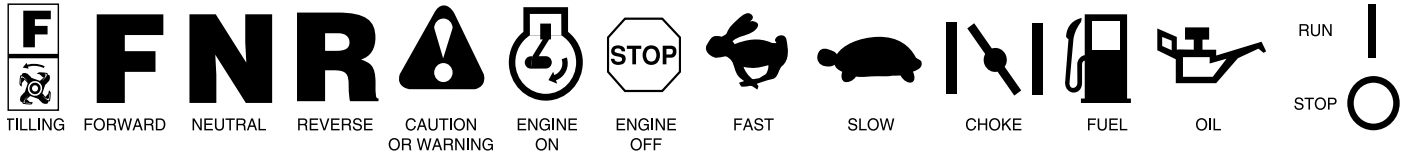

FIG. 8

MEETS ANSI SAFETY REQUIREMENTS

Our tillers conform to the safety standards of the American National Standards Institute.

DEPTH STAKE - Controls depth at which tiller will dig.

DRIVE CONTROL BAR - Used to engage tines.

LEVELING SHIELD - Levels tilled soil.

OUTER SIDE SHIELD - Adjustable to protect small plants from being buried.

SHIFT LEVER - Used to shift transmission gears.

SHIFT LEVER INDICATOR - Shows which gear the transmission is in.

RECOIL STARTER HANDLE - Used to start the engine.

OPERATION



The operation of any tiller can result in foreign objects thrown into the eyes, which can result in severe eye damage. Always wear safety glasses or eye shields before starting your tiller and while tilling. We recommend a wide vision safety mask for over spectacles or standard safety glasses.

HOW TO USE YOUR TILLER

Know how to operate all controls before adding fuel and oil or attempting to start engine.

STOPPING (See Fig. 9)

TINES AND DRIVE

- Release drive control bar to stop movement.
- Move shift lever to “N” (neutral) position.

ENGINE

- Move throttle control to “STOP” position. If equipped with stop switch, move switch to “STOP” position.
- Never use choke to stop engine.

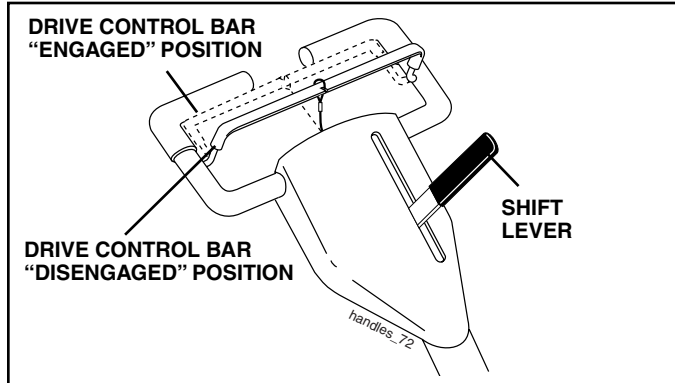



FIG. 9

TINE OPERATION - WITH WHEEL DRIVE

- Always release drive control bar before moving shift lever into another position.
- Tine movement is achieved by moving shift lever to  till position and engaging drive control bar.

FORWARD - WHEELS ONLY/TINES STOPPED

- Release drive control bar and move shift lever indicator to “F” (forward) position. Engage drive control bar and tiller will move forward.

REVERSE - WHEELS ONLY/TINES STOPPED

- DO NOT STAND DIRECTLY BEHIND TILLER.
- Release the drive control bar.
- Move throttle control to “SLOW” position.
- Move shift lever indicator to “R” (reverse) position.
- Hold drive control bar against the handle to start tiller movement.

HARD TO SHIFT GEARS

- Briefly engage drive control bar and release or rock tiller forward and backward until are able to shift gears.

DEPTH STAKE (See Fig. 10)

The depth stake can be raised or lowered to allow you more versatile tilling and cultivating, or to more easily transport your tiller.

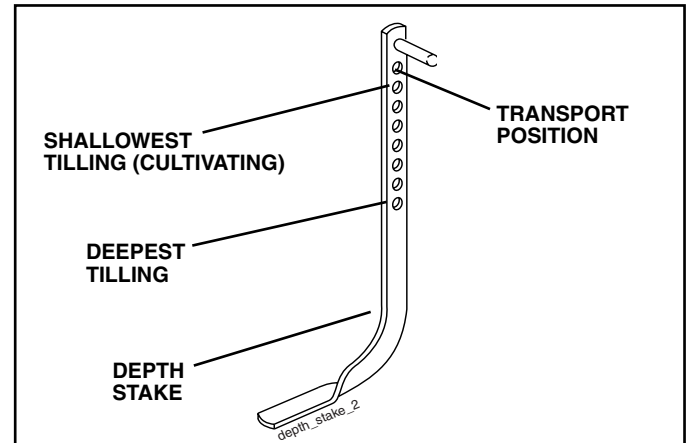

FIG. 10

TILLING (See Fig. 11)

- Release depth stake pin. Pull the depth stake up for increased tilling depth. Place depth stake pin in hole of depth stake to lock in position.
- Place shift lever indicator in till position.
- Hold the drive control bar against the handle to start tilling movement. Tines and wheels will both turn.
- Move throttle control to “FAST” position for deep tilling. To cultivate, throttle control can be set at any desired speed, depending on how fast or slow you wish to cultivate.

IMPORTANT: ALWAYS RELEASE DRIVE CONTROL BAR BEFORE MOVING SHIFT LEVER INTO ANOTHER POSITION.

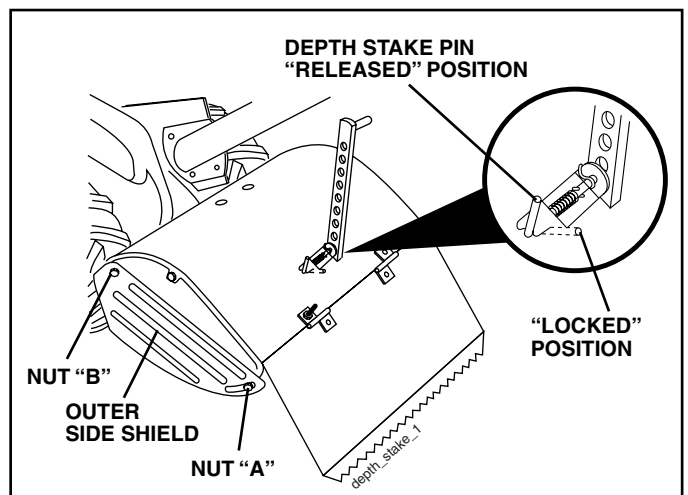

FIG. 11

OPERATION

TURNING

- Release the drive control bar.
- Move throttle control to "SLOW" position.
- Place shift lever indicator in "F" (forward) position. Tines will not turn.
- Lift handle to raise tines out of ground.
- Swing the handle in the opposite direction you wish to turn, being careful to keep feet and legs away from tines.
- When you have completed your turn-around, release the drive control bar and lower handle. Place shift lever in till position and move throttle control to desired speed. To begin tilling, hold drive control bar against the handle.

OUTER SIDE SHIELDS (See Fig. 11)

The back edges of the outer side shields are slotted so that the shields can be raised for deep tilling and lowered for shallow tilling to protect small plants from being buried. Loosen nut "A" in slot and nut "B". Move shield to desired position (both sides). Retighten nuts.

TO TRANSPORT



CAUTION: Before lifting or transporting, allow tiller engine and muffler to cool. Disconnect spark plug wire. Drain gasoline from fuel tank.

AROUND THE YARD

- Release the depth stake pin. Move the depth stake down to the top hole for transporting the tiller. Place depth stake pin in hole of depth stake to lock in position. This prevents tines from scuffing the ground.
- Place shift lever indicator in "F" (forward) position for transporting.
- Hold the drive control bar against the handle to start tiller movement. Tines will not turn.
- Move throttle control to desired speed.

AROUND TOWN

- Disconnect spark plug wire.
- Drain fuel tank.
- Transport in upright position to prevent oil leakage.

BEFORE STARTING ENGINE

IMPORTANT: BE VERY CAREFUL NOT TO ALLOW DIRT TO ENTER THE ENGINE WHEN CHECKING OR ADDING OIL OR FUEL. USE CLEAN OIL AND FUEL AND STORE IN APPROVED, CLEAN, COVERED CONTAINERS. USE CLEAN FILL FUNNELS.

CHECK ENGINE OIL LEVEL (See Fig. 12)

- The engine in your unit has been shipped, from the factory, already filled with SAE 30 summer weight oil.
- With engine level, clean area around oil filler plug and remove plug.

- Engine oil should be to point of overflowing when engine is level. For approximate capacity see "PRODUCT SPECIFICATIONS" on page 3 of this manual. All oil must meet A.P.I. Service Classification SG-SL
- For cold weather operation you should change oil for easier starting (See oil viscosity chart in the Maintenance section of this manual).
- To change engine oil, see the Maintenance section in this manual.

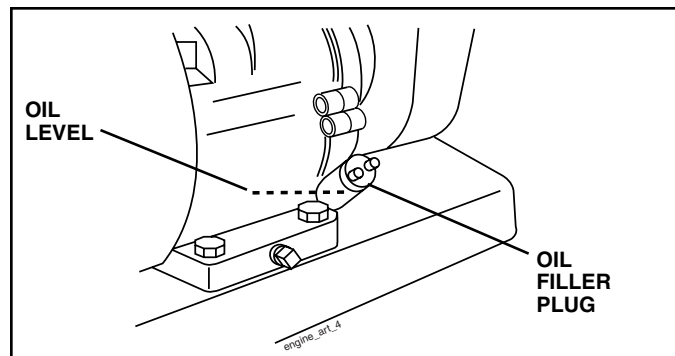

FIG. 12

ADD GASOLINE

- Fill fuel tank to bottom of filler neck. Do not overfill. Use fresh, clean, regular unleaded gasoline with a minimum of 87 octane. (Use of leaded gasoline will increase carbon and lead oxide deposits and reduce valve life). Do not mix oil with gasoline. Purchase fuel in quantities that can be used within 30 days to assure fuel freshness.



CAUTION: Fill to within 1/2 inch of top of fuel tank to prevent spills and to allow for fuel expansion. If gasoline is accidentally spilled, move machine away from area of spill. Avoid creating any source of ignition until gasoline vapors have disappeared.

Wipe off any spilled oil or fuel. Do not store, spill or use gasoline near an open flame.

IMPORTANT: WHEN OPERATING IN TEMPERATURES BELOW 32°F (0°C), USE FRESH, CLEAN WINTER GRADE GASOLINE TO HELP INSURE GOOD COLD WEATHER STARTING.

CAUTION: Alcohol blended fuels (called gasohol or using ethanol or methanol) can attract moisture which leads to separation and formation of acids during storage. Acidic gas can damage the fuel system of an engine while in storage. To avoid engine problems, the fuel system should be emptied before storage of 30 days or longer. Drain the gas tank, start the engine and let it run until the fuel lines and carburetor are empty. Use fresh fuel next season. See Storage Instructions for additional information. Never use engine or carburetor cleaner products in the fuel tank or permanent damage may occur.

OPERATION

TO START ENGINE (See Fig. 13)



CAUTION: Keep drive control bar in “DISENGAGED” position when starting engine.

When starting engine for the first time or if engine has run out of fuel, it will take extra pulls of the recoil starter to move fuel from the tank to the engine.

- Make sure spark plug wire is properly connected.
- Move shift lever indicator to “N” (neutral) position.
- Place throttle control in “FAST” position.
- Move choke control to full “CHOKE” position. Grasp recoil starter handle with one hand and grasp tiller handle with other hand. Pull rope out slowly until engine reaches start of compression cycle (rope will pull slightly harder at this point).
- Pull recoil starter handle quickly. Do not let starter handle snap back against starter. Repeat if necessary.
- If engine fires but does not start, move choke control to half choke position. Pull recoil starter handle until engine starts.
- When engine starts, slowly move choke control to “RUN” position as engine warms up.

NOTE: A warm engine requires less choking to start.

- Move throttle control to desired running position.
- Allow engine to warm up for a few minutes before engaging tines.

NOTE: If at a high altitude (above 3000 feet) or in cold temperatures (below 32°F), the carburetor fuel mixture may need to be adjusted for best engine performance. See “TO ADJUST CARBURETOR” in the Service and Adjustments section of this manual.

NOTE: If engine does not start, see troubleshooting points.

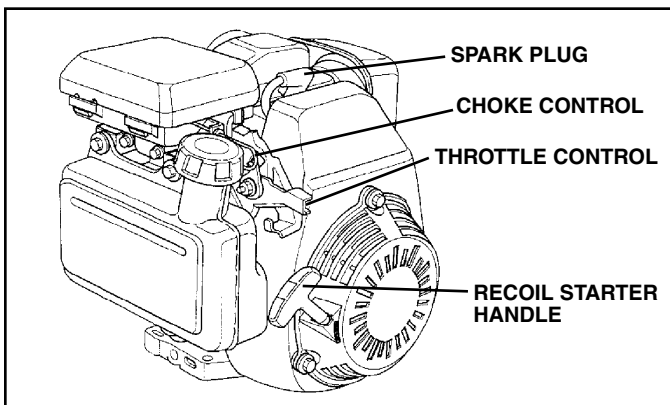

FIG. 13

TILLING HINTS



CAUTION: Until you are accustomed to handling your tiller, start actual field use with throttle in slow position.

- Tilling is digging into, turning over, and breaking up packed soil before planting. Loose, unpacked soil helps root growth. Best tilling depth is 4" to 6" (10-15cm). A tiller will also clear the soil of unwanted vegetation. The decomposition of this vegetable matter enriches the soil. Depending on the climate (rainfall and wind), it may be advisable to till the soil at the end of the growing season to further condition the soil.
- Soil conditions are important for proper tilling. Tines will not readily penetrate dry, hard soil which may contribute to excessive bounce and difficult handling of your tiller. Hard soil should be moistened before tilling; however, extremely wet soil will “ball-up” or clump during tilling. Wait until the soil is less wet in order to achieve the best results. When tilling in the fall, remove vines and long grass to prevent them from wrapping around the tine shaft and slowing your tilling operation.
- You will find tilling much easier if you leave a row untilled between passes. Then go back between tilled rows. (See Fig. 14) There are two reasons for doing this. First, wide turns are much easier to negotiate than about-faces. Second, the tiller won't be pulling itself, and you, toward the row next to it.
- Do not lean on handle. This takes weight off the wheels and reduces traction. To get through a really tough section of sod or hard ground, apply upward pressure on handle or lower the depth stake.

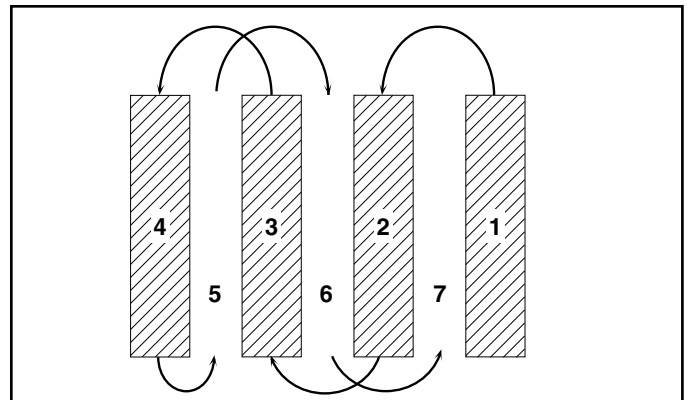

FIG. 14

TINE SHEAR PINS

The tine assemblies on your tiller are secured to the tine shaft with shear pins (See “TINE REPLACEMENT” in the Service and Adjustments section of this manual).

If the tiller is unusually overloaded or jammed, the shear pins are designed to break before internal damage occurs to the transmission.

- If shear pin(s) break, replace only with those shown in the Repair Parts section of this manual.

OPERATION

CULTIVATING

Cultivating is destroying the weeds between rows to prevent them from robbing nourishment and moisture from the plants. At the same time, breaking up the upper layer of soil crust will help retain moisture in the soil. Best digging depth is 1" to 3" (2.5-7.5 cm). Lower the outer side shields to protect small plants from being buried.

- Cultivate up and down the rows at a speed which will allow tines to uproot weeds and leave the ground in rough condition, promoting no further growth of weeds and grass (See Fig. 15).

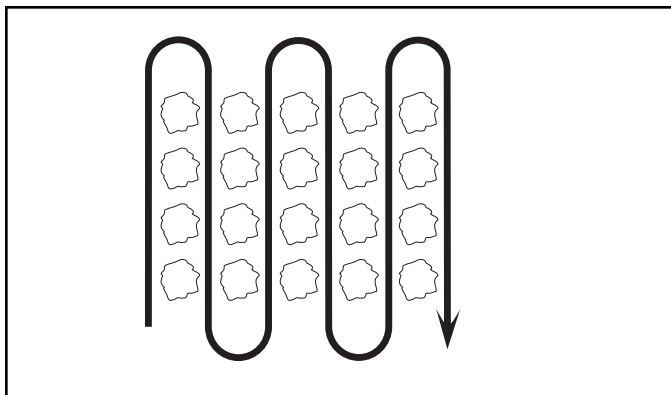

FIG. 15

ADJUST WHEELS FOR CULTIVATING (See Figs. 16 and 17)

- Place blocks under right hand side of tiller and remove hairpin clip and clevis pin from right hand wheel.
- Move wheel outward approximately 1 inch until hole in inner wheel hub lines up with inner hole in axle.
- Replace clevis pin and hairpin clip on inside of wheel and remove blocks.
- Repeat preceding steps on left hand side.

NOTE: In extremely rough conditions and while cultivating, the wheels should be moved outward on the axle for increased stability.

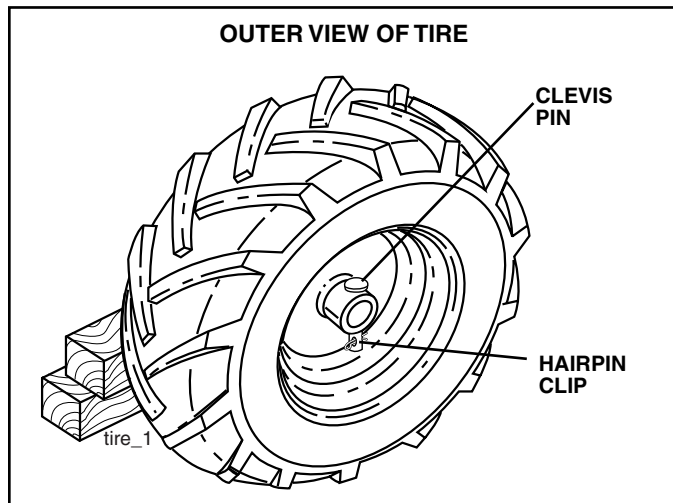

FIG. 16

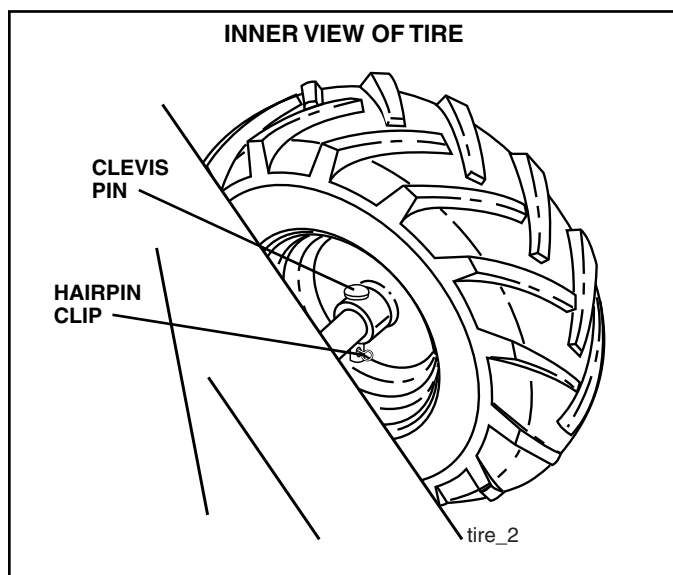

FIG. 17

MAINTENANCE

MAINTENANCE SCHEDULE	SERVICE DATES											
	BEFORE EACH USE	EVERY 5 HOURS	EVERY 25 HOURS	EVERY 50 HOURS	EVERY SEASON							
FILL IN DATES AS YOU COMPLETE REGULAR SERVICE												
Check Engine Oil Level	✓	✓										
Change Engine Oil				✓ _{1,2}								
Oil Pivot Points		✓										
Inspect Spark Arrester / Muffler				✓								
Inspect Air Screen	✓											
Clean or Replace Air Cleaner Cartridge				✓ ₂								
Clean Engine Cylinder Fins				✓								
Replace Spark Plug				✓								
RH Gear Case Grease Fitting (1oz.)					✓							

1 - Change more often when operating under a heavy load or in high ambient temperatures.
 2 - Service more often when operating in dirty or dusty conditions.

GENERAL RECOMMENDATIONS

The warranty on this tiller does not cover items that have been subjected to operator abuse or negligence. To receive full value from the warranty, the operator must maintain tiller as instructed in this manual.

Some adjustments will need to be made periodically to properly maintain your tiller.

All adjustments in the Service and Adjustments section of this manual should be checked at least once each season.

- Once a year you should replace the spark plug, clean or replace air filter, and check tines and belts for wear. A new spark plug and clean air filter assure proper air-fuel mixture and help your engine run better and last longer.

BEFORE EACH USE

- Check engine oil level.
- Check tine operation.
- Check for loose fasteners.

LUBRICATION

Keep unit well lubricated (See "LUBRICATION CHART")

LUBRICATION CHART

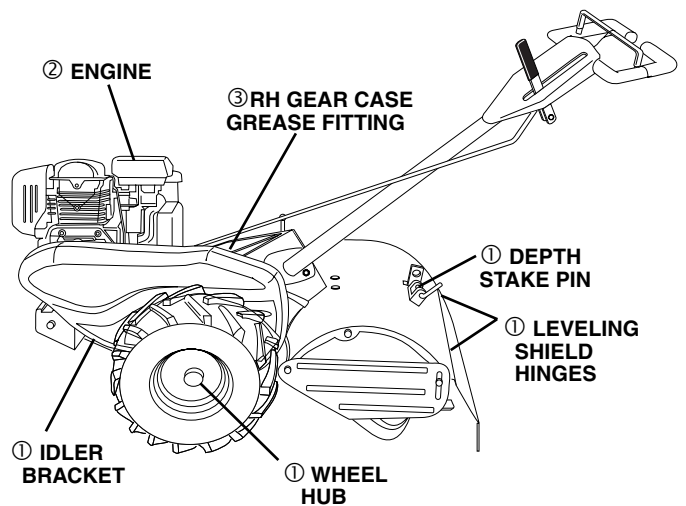

- ① SAE 30 OR 10W-30 MOTOR OIL
- ② REFER TO MAINTENANCE "ENGINE" SECTION
- ③ EP #1 GREASE

MAINTENANCE



Disconnect spark plug wire before performing any maintenance (except carburetor adjustment) to prevent accidental starting of engine.
Prevent fires! Keep the engine free of grass, leaves, spilled oil, or fuel. Remove fuel from tank before tipping unit for maintenance. Clean muffler area of all grass, dirt, and debris.
Do not touch hot muffler or cylinder fins as contact may cause burns.

ENGINE

LUBRICATION

Use only high quality detergent oil rated with API service classification SG-SL. Select the oil's SAE viscosity grade according to your expected temperature.

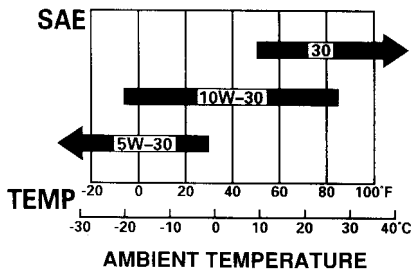

FIG. 18

NOTE: Although multi-viscosity oils (5W-30, 10W-30, etc.) improve starting in cold weather, these multi-viscosity oils will result in increased oil consumption when used above 40°F (4°C). Check your engine oil level more frequently to avoid possible engine damage from running low on oil.

Change the oil after every 25 hours of operation or at least once a year if the tiller is not used for 25 hours in one year.

Check the crankcase oil level before starting the engine and after each five (5) hours of continuous use. Add SAE 30 motor oil or equivalent. Tighten oil filler plug securely each time you check the oil level.

TO CHANGE ENGINE OIL (See Figs. 18 and 19)

Determine temperature range expected before oil change. All oil must meet API service classification SG-SL.

- Be sure tiller is on level surface.
- Oil will drain more freely when warm.
- Use a funnel to prevent oil spill on tiller, and catch oil in a suitable container.
- Remove drain plug.
- Tip tiller forward to drain oil.
- After oil has drained completely, replace oil drain plug and tighten securely.
- Refill engine with oil. See "CHECK ENGINE OIL LEVEL" in the Operation section of this manual.
- Replace oil drain plug and tighten securely.

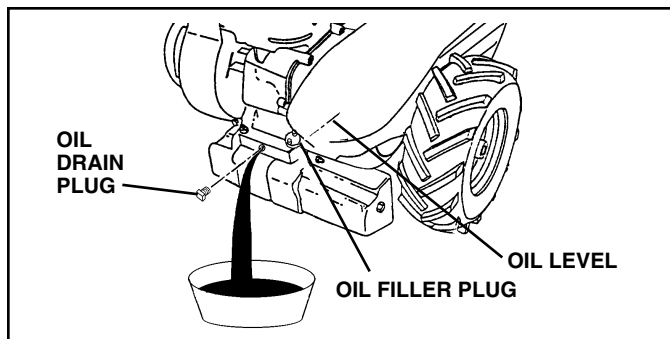

FIG. 19

AIR FILTER (See Fig. 20)

Your engine will not run properly and may be damaged by using a dirty air filter. Replace the air filter every 100 hours of operation or every season, whichever occurs first. Service air cleaner more often under dusty conditions.

TO CLEAN AIR FILTER

- Remove cover.
- Carefully remove cartridge.
- Clean by gently tapping on a flat surface. If very dirty, replace cartridge.
- Install cartridge, then replace cover.

IMPORTANT: PETROLEUM SOLVENTS, SUCH AS KEROSENE, ARE NOT TO BE USED TO CLEAN CARTRIDGE. THEY MAY CAUSE DETERIORATION OF THE CARTRIDGE. DO NOT OIL CARTRIDGE. DO NOT USE PRESSURIZED AIR TO CLEAN OR DRY CARTRIDGE.

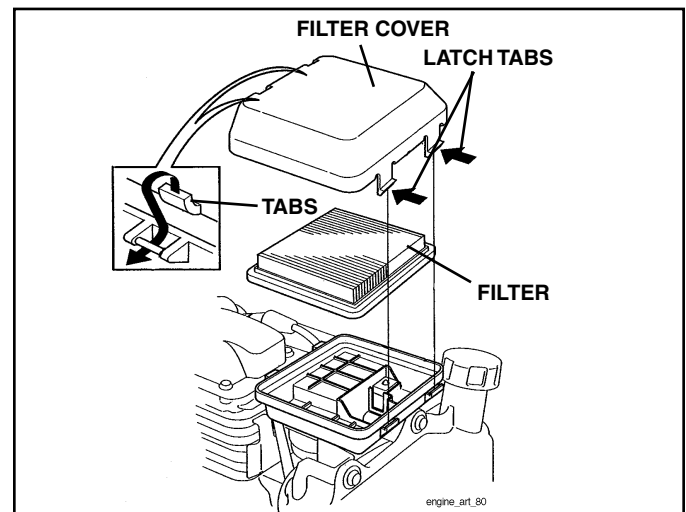

FIG. 20

MUFFLER

Do not operate tiller without muffler. Do not tamper with exhaust system. Damaged mufflers or spark arresters could create a fire hazard. Inspect periodically and replace if necessary. If your engine is equipped with a spark arrester screen assembly, remove every 50 hours for cleaning and inspection. Replace if damaged.

SPARK PLUG

Replace spark plugs at the beginning of each tilling season or after every 50 hours of use, whichever comes first. Spark plug type and gap setting are shown in "PRODUCT SPECIFICATIONS" on page 3 of this manual.

TRANSMISSION

Once a season, lubricate the right hand side gear case grease fitting with 1 oz. of EP #1 Grease.

MAINTENANCE

CLEANING

Do not clean your tiller when the engine and transmission are hot. We do not recommend using pressurized water (garden hose, etc.) to clean your unit unless the gasket area around the transmission and the engine muffler, air filter and carburetor are covered to keep water out. Water in engine will shorten the useful life of your tiller.

- Clean engine, wheels, finish, etc. of all foreign matter.
- Keep finished surfaces and wheels free of all gasoline, oil, etc.
- Protect painted surfaces with automotive type wax.

SERVICE AND ADJUSTMENTS



CAUTION: Disconnect spark plug wire from spark plug and place wire where it cannot come into contact with plug.

TILLER

TO ADJUST HANDLE HEIGHT (See Fig. 21)

Select handle height best suited for your tilling conditions. Handle height will be different when tiller digs into soil.

- First loosen handle lock lever.
- Handle can be positioned at different settings between "HIGH" and "LOW" positions.
- Retighten handle lock lever securely after adjusting.

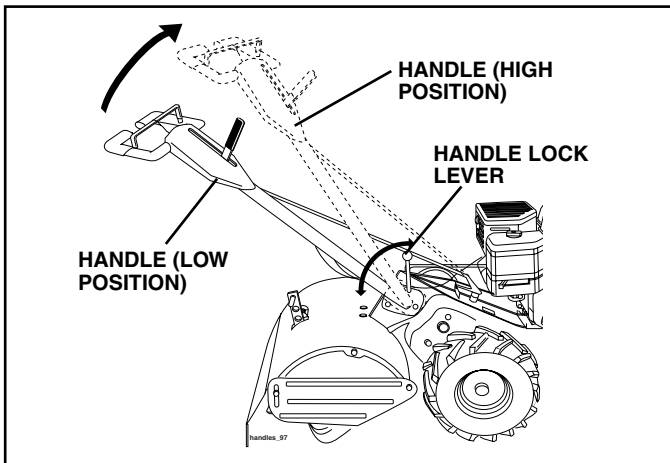

FIG. 21

TIRE CARE



CAUTION: When mounting tires, unless beads are seated, overinflation can cause an explosion.

- Maintain 20 pounds of tire pressure. If tire pressures are not equal, tiller will pull to one side.
- Keep tires free of gasoline or oil which can damage rubber.

TO REMOVE WHEEL (See Fig. 22)

- Place blocks under transmission to keep tiller from tipping.
- Remove hairpin clip and clevis pin from wheel.
- Remove wheel and tire.
- Repair tire and reassemble.

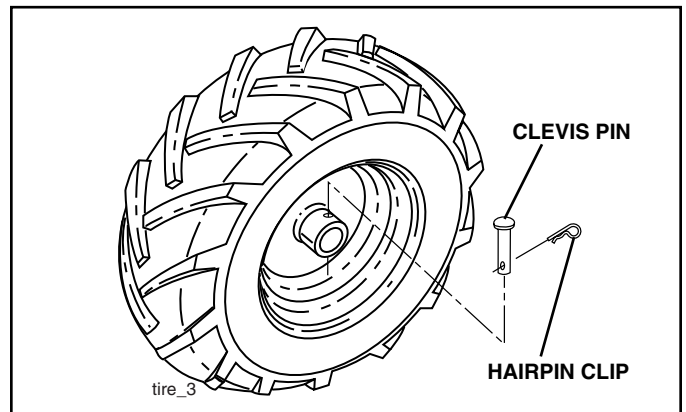

FIG. 22

TO REMOVE BELT GUARD (See Fig. 23)

- Remove L.H. outer and inner side shields (See "TO REMOVE WHEEL" in this section of this manual).
- Remove hairpin clip and clevis pin from left wheel. Pull wheel out from tiller about 1 inch.
- Remove two (2) screws from side of belt guard.
- Remove hex nut and washer from bottom of belt guard (located behind wheel).
- Pull belt guard out and away from unit.
- Replace belt guard by reversing above procedure.

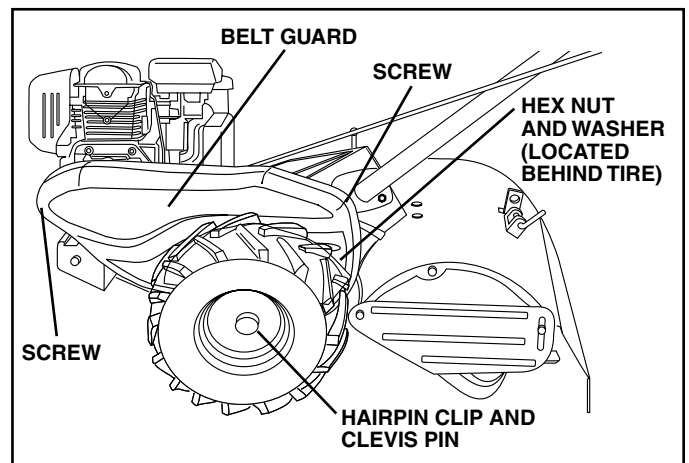

FIG. 23

SERVICE AND ADJUSTMENTS

TINE REPLACEMENT (See Figs. 24, 25 and 26)



CAUTION: Tines are sharp. Wear gloves or other protection when handling tines.

A badly worn tine causes your tiller to work harder and dig more shallow. Most important, worn tines cannot chop and shred organic matter as effectively nor bury it as deeply as good tines. A tine this worn needs to be replaced.

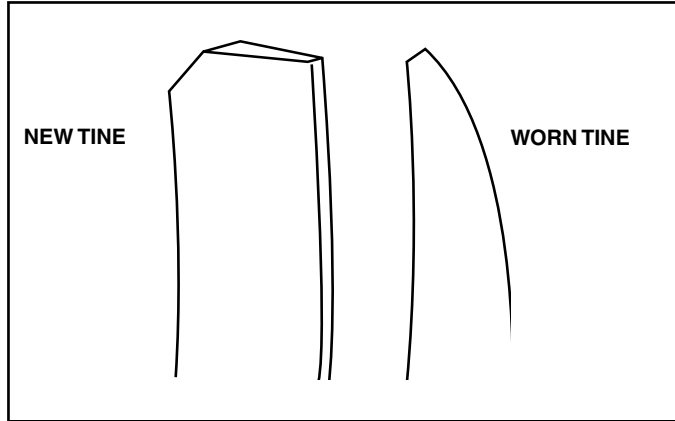

FIG. 24

- To maintain the superb tilling performance of this machine the tines should be checked for sharpness, wear, and bending, particularly the tines which are next to the transmission. If the gap between the tines exceeds 3-1/2 inches they should be replaced or straightened as necessary.
- New tines should be assembled as shown in Fig. 26. Sharpened tine edges will rotate rearward from above.

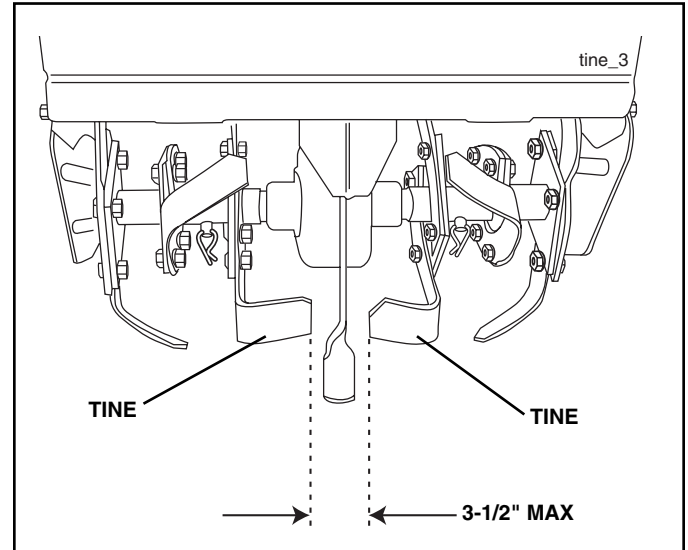

FIG. 25

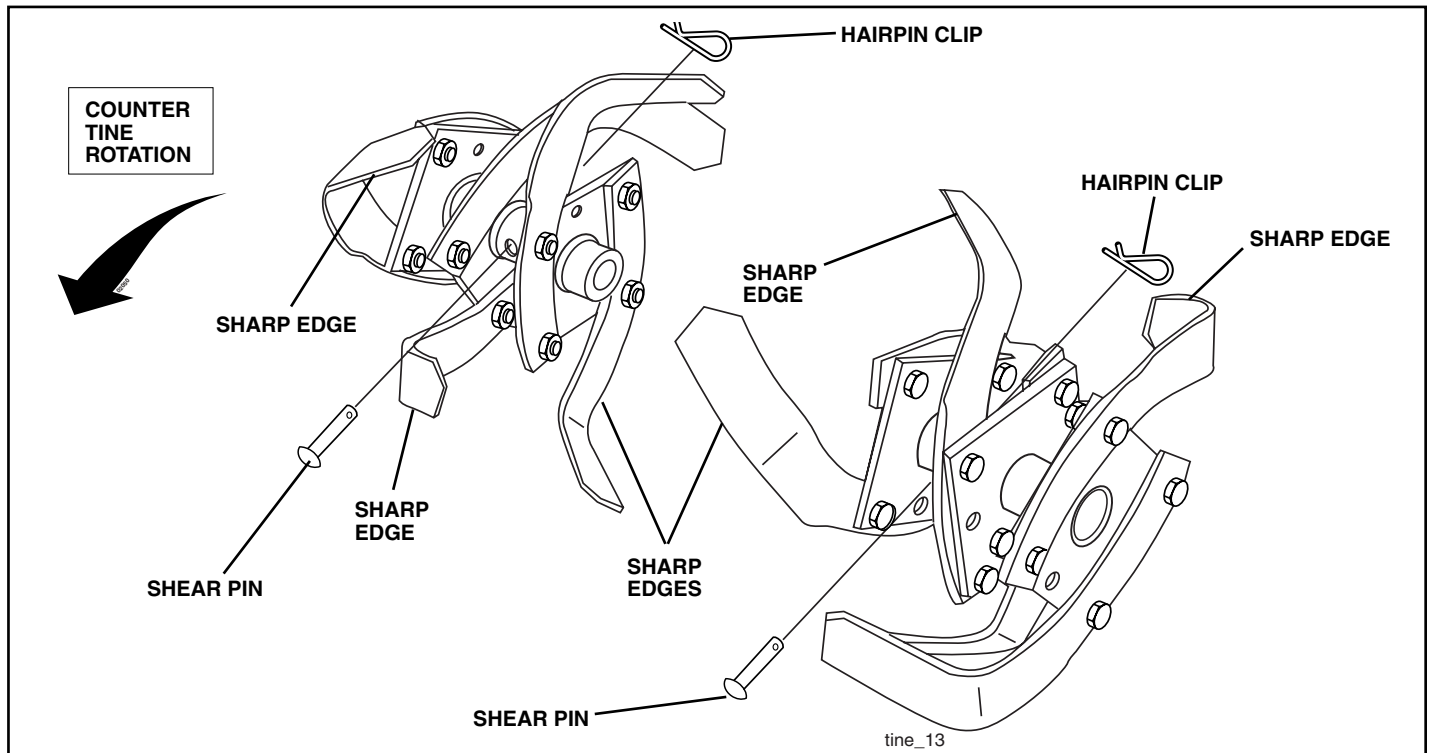

FIG. 26

SERVICE AND ADJUSTMENTS

TO REPLACE GROUND DRIVE BELT (See Figs. 23 and 28)

- Remove belt guard (See "TO REMOVE BELT GUARD" in this section of this manual).
- Remove old belt by slipping off engine pulley first then remove from transmission pulley.
- Place new belt in groove of transmission pulley and into engine pulley. BELT MUST BE IN GROOVE ON TOP OF IDLER PULLEY. NOTE POSITION OF BELT TO GUIDES.
- Check belt adjustment as described below.
- Replace belt guard.
- Reposition wheel and replace clevis pin and hairpin clip.
- Replace inner and outer side shields.

GROUND DRIVE BELT ADJUSTMENT (See Fig. 28)

For proper belt tension, the extension spring should have about 5/8 inch stretch when drive control bar is in "ENGAGED" position. This tension can be attained as follows:

- Loosen cable clip screw securing the drive control cable.
- Slide cable forward for less tension and rearward for more tension until about 5/8 inch stretch is obtained while the drive control bar is engaged.
- Tighten cable clip screw securely.

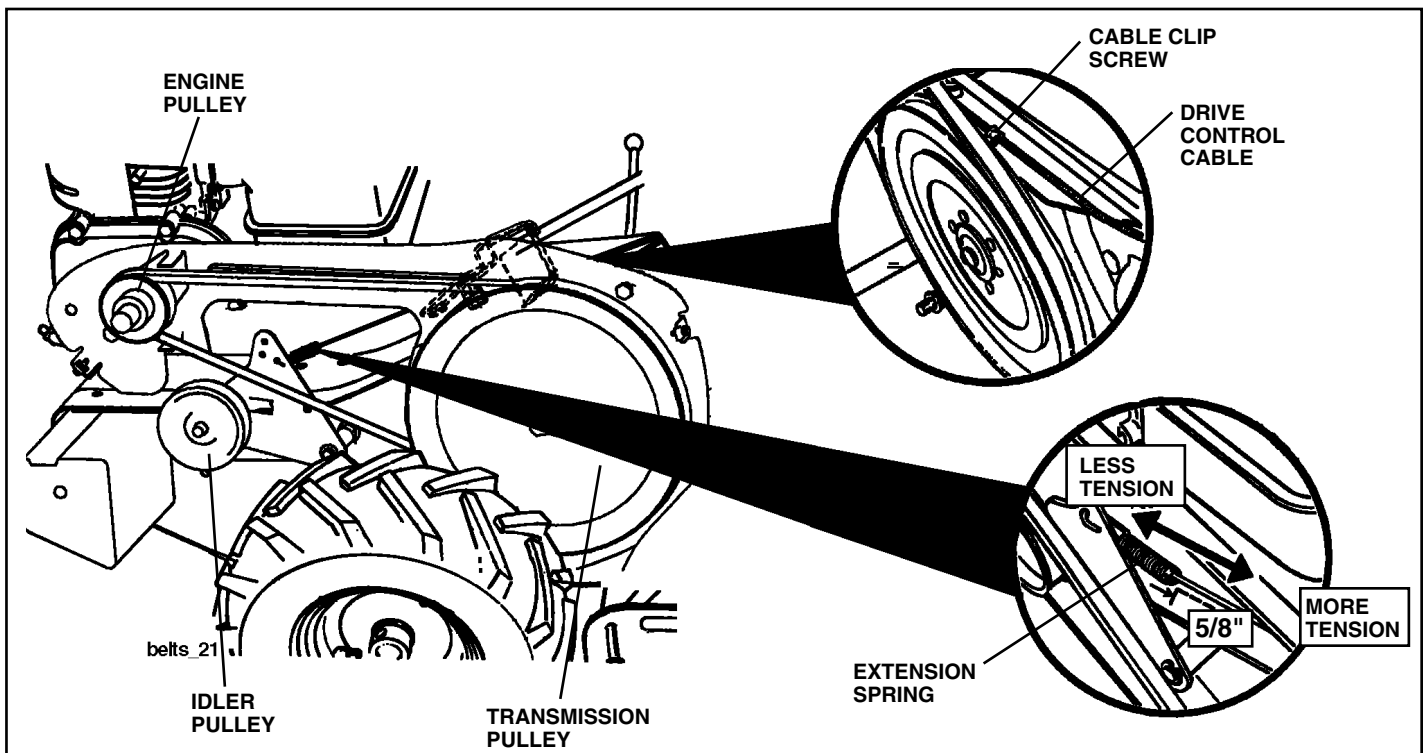

FIG. 28

ENGINE

Maintenance, repair, or replacement of the emission control devices and systems, which are being done at the customer's expense, may be performed by any non-road engine repair establishment or individual. Warranty repairs must be performed by an authorized engine manufacturer's service outlet.

TO ADJUST CARBURETOR

The carburetor has been preset at the factory and adjustment should not be necessary. However, engine performance can be affected by differences in fuel, temperature, altitude or load. If the carburetor does need adjustment, contact your nearest Sears or other qualified service center.

IMPORTANT: NEVER TAMPER WITH THE ENGINE GOVERNOR, WHICH IS FACTORY SET FOR PROPER ENGINE SPEED. OVERSPEEDING THE ENGINE ABOVE THE FACTORY HIGH SPEED SETTING CAN BE DANGEROUS. IF YOU THINK THE ENGINE-GOVERNED HIGH SPEED NEEDS ADJUSTING, CONTACT YOUR NEAREST SEARS OR OTHER QUALIFIED SERVICE CENTER WHICH HAS THE PROPER EQUIPMENT AND EXPERIENCE TO MAKE ANY NECESSARY ADJUSTMENTS.

STORAGE

Immediately prepare your tiller for storage at the end of the season or if the unit will not be used for 30 days or more.



WARNING: Never store the tiller with gasoline in the tank inside a building where fumes may reach an open flame or spark. Allow the engine to cool before storing in any enclosure.

TILLER

- Clean entire tiller (See “CLEANING” in the Maintenance section of this manual).
- Inspect and replace belts, if necessary (See belt replacement instructions in the Service and Adjustments section of this manual).
- Lubricate as shown in the Maintenance section of this manual.
- Be sure that all nuts, bolts and screws are securely fastened. Inspect moving parts for damage, breakage and wear. Replace if necessary.
- Touch up all rusted or chipped paint surfaces; sand lightly before painting.

ENGINE

FUEL SYSTEM

IMPORTANT: IT IS IMPORTANT TO PREVENT GUM DEPOSITS FROM FORMING IN ESSENTIAL FUEL SYSTEM PARTS SUCH AS THE CARBURETOR, FUEL FILTER, FUEL HOSE, OR TANK DURING STORAGE. ALSO, EXPERIENCE INDICATES THAT ALCOHOL BLENDED FUELS (CALLED GASOHOL OR USING ETHANOL OR METHANOL) CAN ATTRACT MOISTURE WHICH LEADS TO SEPARATION AND FORMATION OF ACIDS DURING STORAGE. ACIDIC GAS CAN DAMAGE THE FUEL SYSTEM OF AN ENGINE WHILE IN STORAGE.

- Drain the fuel tank.
- Start the engine and let it run until the fuel lines and carburetor are empty.
- Never use engine or carburetor cleaner products in the fuel tank or permanent.

NOTE: Fuel stabilizer is an acceptable alternative in minimizing the formation of fuel gum deposits during storage. Add stabilizer to gasoline in fuel tank or storage container. Always follow the mix ratio found on stabilizer container. Run engine at least 10 minutes after adding stabilizer to allow the stabilizer to reach the carburetor. Do not drain the gas tank and carburetor if using fuel stabilizer.

ENGINE OIL

Drain oil (with engine warm) and replace with clean oil. (See “ENGINE” in the Maintenance section of this manual).

CYLINDER(S)

- Remove spark plug.
- Pour 1 ounce (29 ml) of oil through spark plug hole into cylinder.
- Pull starter handle slowly several times to distribute oil.
- Replace with new spark plug.

OTHER

- Do not store gasoline from one season to another.
- Replace your gasoline can if your can starts to rust. Rust and/or dirt in your gasoline will cause problems.
- If possible, store your unit indoors and cover it to give protection from dust and dirt.
- Cover your unit with a suitable protective cover that does not retain moisture. Do not use plastic. Plastic cannot breathe which allows condensation to form and will cause your unit to rust.

IMPORTANT: NEVER COVER TILLER WHILE ENGINE AND EXHAUST AREAS ARE STILL WARM.

TROUBLESHOOTING POINTS

PROBLEM	CAUSE	CORRECTION
Will not start	<ol style="list-style-type: none"> 1. Out of fuel. 2. Engine flooded. 3. Dirty air cleaner. 4. Water in fuel. 5. Clogged fuel tank. 6. Loose spark plug wire. 7. Bad spark plug or improper gap. 8. Carburetor out of adjustment. 9. Oil soaked air filter. 	<ol style="list-style-type: none"> 1. Fill fuel tank. 2. Wait several minutes before attempting to start. 3. Clean or replace air cleaner cartridge. 4. Drain fuel tank and carburetor, and refill tank with fresh gasoline. 5. Remove fuel tank and clean. 6. Make sure spark plug wire is seated properly on plug. 7. Replace spark plug or adjust gap. 8. Make necessary adjustments. 9. Replace air filter.
Hard to start	<ol style="list-style-type: none"> 1. Throttle control not set properly. 2. Dirty air cleaner. 3. Bad spark plug or improper gap. 4. Stale or dirty fuel. 5. Loose spark plug wire. 6. Carburetor out of adjustment. 	<ol style="list-style-type: none"> 1. Place throttle control in "FAST" position. 2. Clean or replace air cleaner cartridge. 3. Replace spark plug or adjust gap. 4. Drain fuel tank and refill with fresh gasoline. 5. Make sure spark plug wire is seated properly on plug. 6. Make necessary adjustments.
Loss of power	<ol style="list-style-type: none"> 1. Engine is overloaded. 2. Dirty air cleaner. 3. Low oil level/dirty oil. 4. Faulty spark plug. 5. Oil in fuel. 6. Stale or dirty fuel. 7. Water in fuel. 8. Clogged fuel tank. 9. Spark plug wire loose. 10. Dirty engine air screen. 11. Dirty/clogged muffler. 12. Carburetor out of adjustment. 13. Poor compression. 	<ol style="list-style-type: none"> 1. Set depth stake for shallower tilling. 2. Clean or replace air cleaner cartridge. 3. Check oil level/change oil. 4. Clean and regap or change spark plug. 5. Drain and clean fuel tank and refill, and clean carburetor. 6. Drain fuel tank and refill with fresh gasoline. 7. Drain fuel tank and carburetor, and refill tank with fresh gasoline. 8. Remove fuel tank and clean. 9. Connect and tighten spark plug wire. 10. Clean engine air screen. 11. Clean/replace muffler. 12. Make necessary adjustments. 13. Contact an authorized service center/department.
Engine overheats	<ol style="list-style-type: none"> 1. Low oil level/dirty oil. 2. Dirty engine air screen. 3. Dirty engine. 4. Partially plugged muffler. 5. Improper carburetor adjustment. 	<ol style="list-style-type: none"> 1. Check oil level/change oil. 2. Clean engine air screen. 3. Clean cylinder fins, air screen, and muffler area. 4. Remove and clean muffler. 5. Adjust carburetor to richer position.
Excessive bounce/ difficult handling	<ol style="list-style-type: none"> 1. Ground too dry and hard. 	<ol style="list-style-type: none"> 1. Moisten ground or wait for more favorable soil conditions.
Soil balls up or clumps	<ol style="list-style-type: none"> 1. Ground too wet. 	<ol style="list-style-type: none"> 1. Wait for more favorable soil conditions.
Engine runs but tiller won't move	<ol style="list-style-type: none"> 1. Drive control bar is not engaged. 2. V-belt not correctly adjusted. 3. V-belt is off pulley(s). 	<ol style="list-style-type: none"> 1. Engage drive control. 2. Inspect/adjust V-belt. 3. Inspect V-belt.
Engine runs but labors when tilling	<ol style="list-style-type: none"> 1. Tilling too deep. 2. Throttle control not properly adjusted. 3. Carburetor out of adjustment. 	<ol style="list-style-type: none"> 1. Set depth stake for shallower tilling. 2. Check throttle control setting. 3. Make necessary adjustments.
Tines will not rotate	<ol style="list-style-type: none"> 1. Shear pin(s) broken. 	<ol style="list-style-type: none"> 1. Replace shear pin(s).

REPAIR PARTS

TILLER - - MODEL NUMBER 944.625930

HANDLES

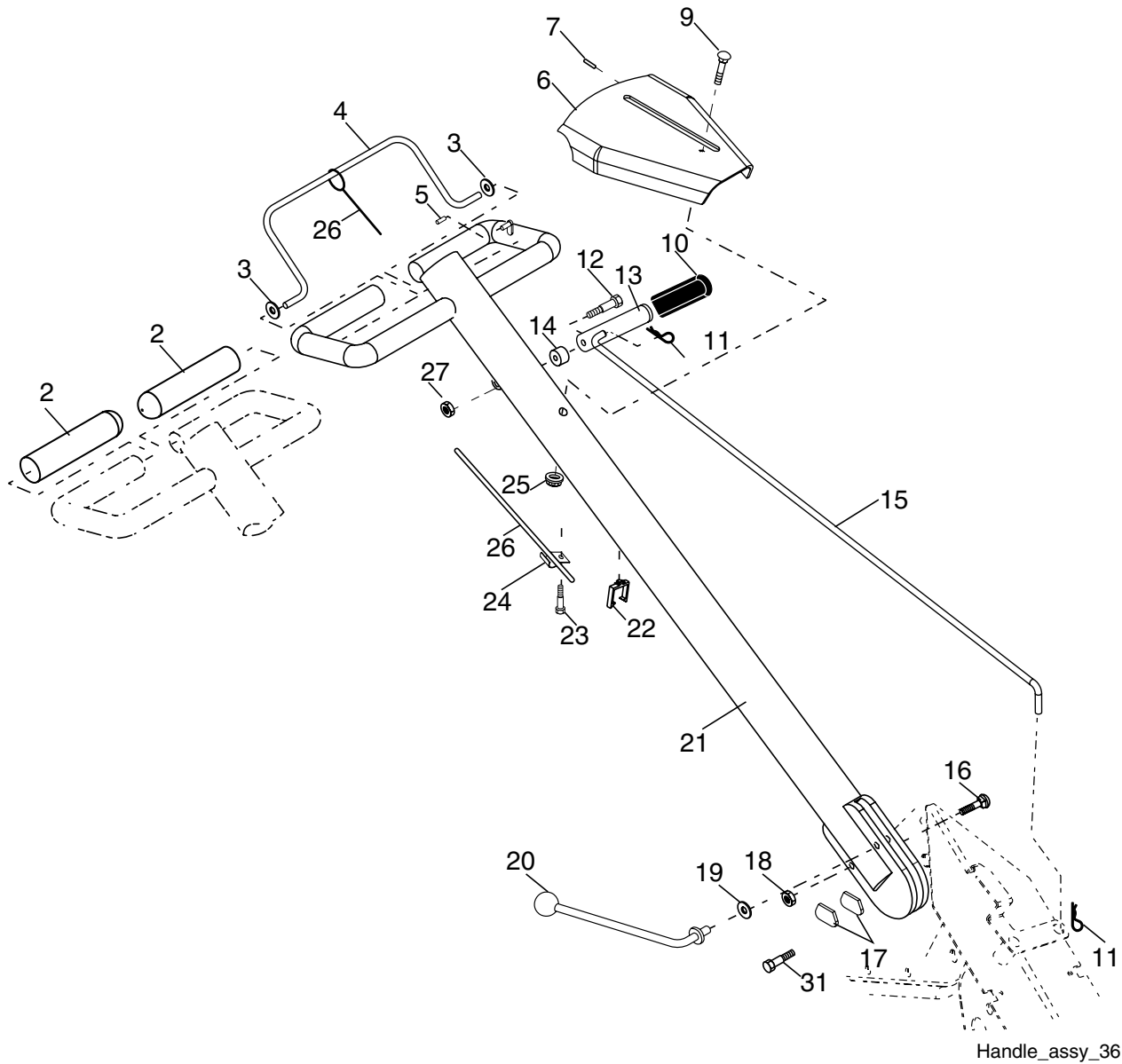

KEY NO.	PART NO.	DESCRIPTION
2	141406	Grip, Handle
3	110673X	Grommet, Handle
4	127254X	Bar, Drive Control Assembly
5	6712J	Cap, Vinyl
6	189347X010	Panel, Control
7	110641X	Bushing, Split
9	72010520	Bolt 5/16-18 unc x 2-1/2
10	110646X	Handle, Grip
11	STD624003	Retainer Spring
12	81328	Bolt, Shoulder
13	187497	Handle, Shift
14	109313X	Grommet, Rubber
15	110702X	Rod, Shift
16	STD533710	Bolt, Carriage 3/8-16 x 1 Gr. 5
17	109229X	Lock, Handle

KEY NO.	PART NO.	DESCRIPTION
18	STD541437	Nut, Crownlock 3/8-16
19	19131611	Washer 13/32 x 1 x 11 Ga.
20	109228X	Lever, Lock, Handle
21	150628	Handle, Assemble
22	165197	Clip, Plastic, Cable
23	86777	Screw, Hex, Washer Hd, Slotted #10-24 x 1/2
24	9484R	Clip
25	73970500	Locknut, Hex, Flange
26	110675X	Clutch, Cable
27	73900400	Nut, Lock 1/4-20
31	150696	Bolt, Pivot

NOTE: All component dimensions given in U.S. inches.
1 inch = 25.4 mm

REPAIR PARTS

TILLER - - MODEL NUMBER 944.625930

MAINFRAME, LEFT SIDE

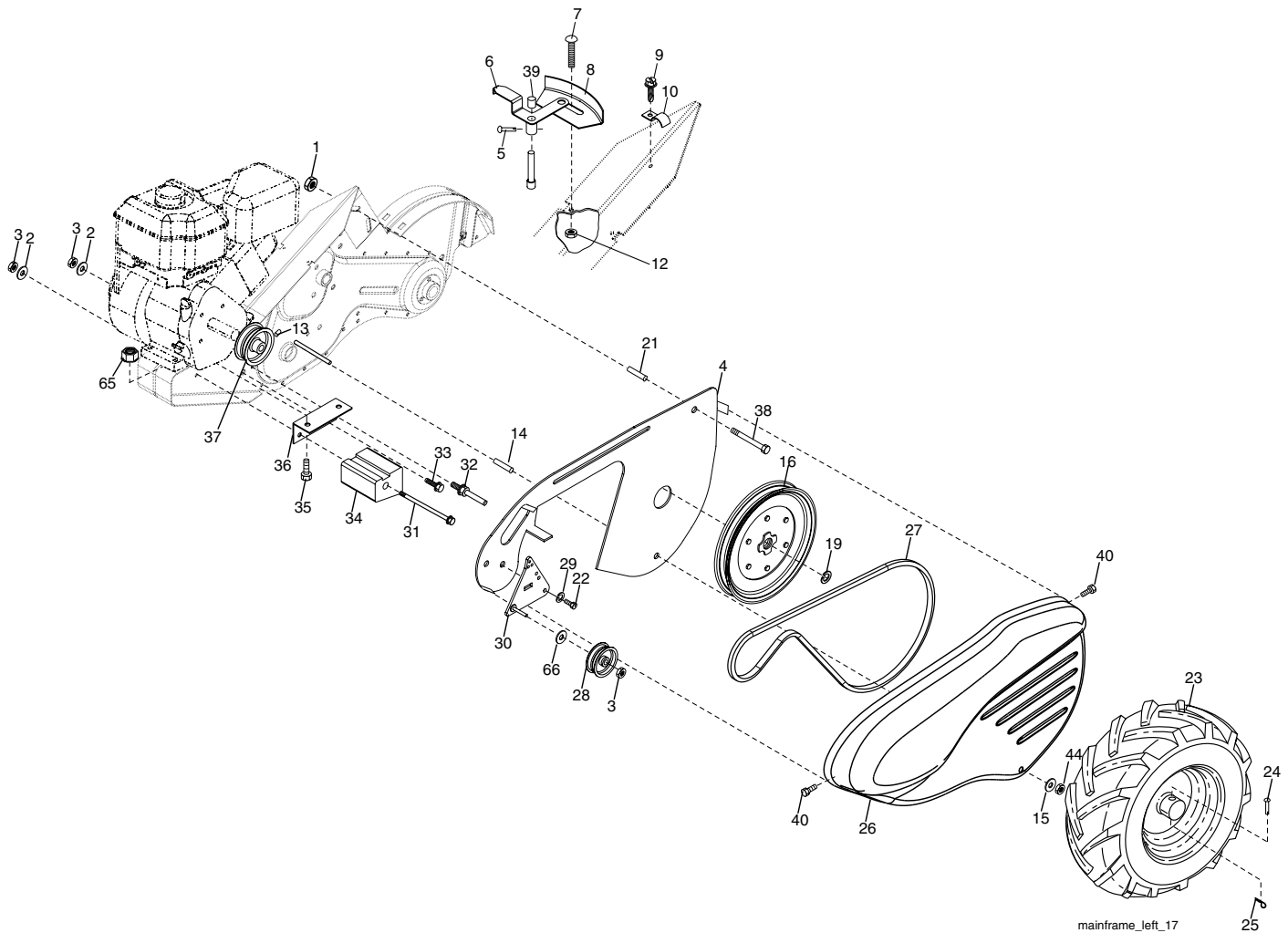

KEY NO.	PART NO.	DESCRIPTION
1	STD541431	Nut, Keps 5/16-18
2	STD551137	Washer, Lock 3/8
3	STD541037	Nut, Hex 3/8-16
4	170127	Shield, Inner Belt Guard
5	164329	Pin Spirol Flared
6	110111X	Lever, Shift
7	STD532505	Bolt, Carriage 1/4-20 x 1/2 Gr. 5
8	8700J	Plate, Shift Indicator
9	86777	Screw, Hex, Washer Head, Slotted #10-24 x 1/2
10	9484R	Clip
12	STD541425	Nut, Hex 1/4-20
13	23230506	Screw, Set, Hex 5/16-18 x 3/8
14	156117	Spacer Split .327 x 42 x 1.220
15	STD551031	Washer 11/32 x 11/16 x 16 Ga.
16	145102	Sheave, Transmission
19	12000028	Ring, Retainer
21	110652X	Spacer, Split 0.327 x 0.42 x 12.09
22	74770508	Belt, Fin Hex 5/16-24 x 1/2
23	102190X	Tire
	183122X624	Rim
	795R	Tire Valve
24	126875X	Rivet, Drilled

KEY NO.	PART NO.	DESCRIPTION
25	STD624003	Clip, Hairpin
26	165501X428	Guard, Belt
27	132801	Belt, V
28	104679X	Pulley, Idler
29	12000032	Ring, Klip
30	159229	Bracket, Idler
31	102384X	Bolt, Hex 5/16-16 x 12
32	102141X	Shaft, Idler Arm
33	STD523710	Bolt, Hex 3/8-16 x 1
34	102383X	Counterweight, L.H.
35	STD523715	Bolt, Hex 5/16-18 x 1-1/2
36	102331X	Bracket, Reinforcement, L.H.
37	130812	Sheave, Engine
38	74760544	Bolt, Fin Hex 5/16-18 x 2-3/4
39	140062	Cap, Plunger, Blk
40	170488	Screw Hex Wsh. Hd # 10-32 x 9/16
44	STD541431	Nut, Lock 5/16-18
65	73970500	Locknut, Hex Flange 5/16-18
66	19131312	Washer 13/32 x 13/16 x 12 Ga.

NOTE: All component dimensions given in U.S. inches.
1 inch = 25.4 mm

REPAIR PARTS

TILLER - - MODEL NUMBER 944.625930

MAINFRAME, RIGHT SIDE

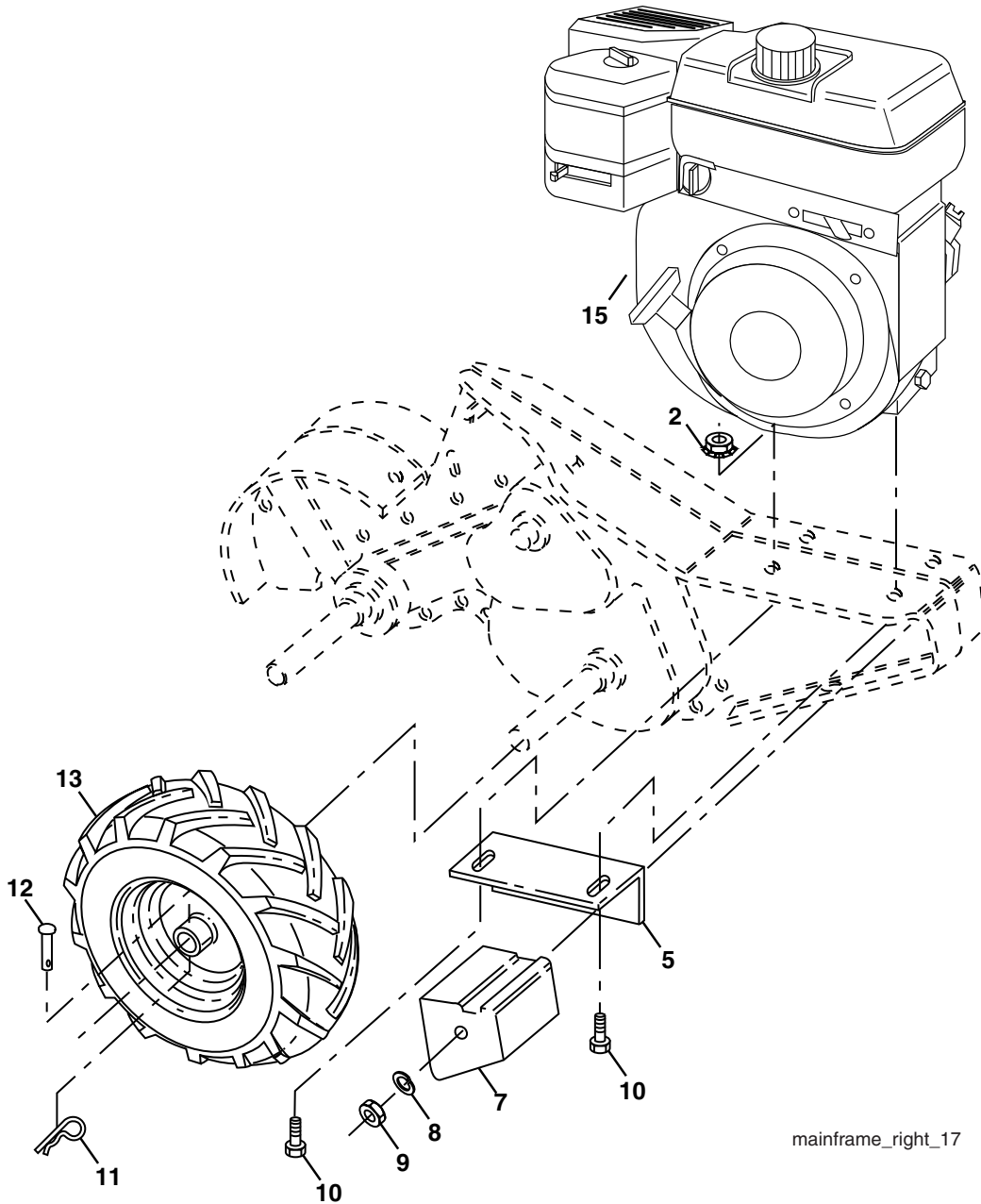

mainframe_right_17

KEY NO.	PART NO.	DESCRIPTION
2	73970500	Locknut, Hex, Flange 5/16-18
5	102332X	Bracket, Reinforcement
7	102173X	Counter Weight, R.H.
8	STD551137 *	Washer, Lock 3/8
9	STD541037 *	Nut, Hex 3/8-16
10	STD523715	Bolt, Hex 5/16-18 x 1-1/2
11	STD624003 *	Clip, Hairpin
12	126875X	Rivet, Drilled

KEY NO.	PART NO.	DESCRIPTION
13	102190X	Tire
	183122X624	Rim
	795R	Tire Valve
15	-----	Engine(See breakdown) Honda Model GC160QHA2

* STANDARD HARDWARE - - PURCHASE LOCALLY

NOTE: All component dimensions given in U.S.inches.
1 inch = 25.4 mm

REPAIR PARTS

TILLER - - MODEL NUMBER 944.625930

TRANSMISSION

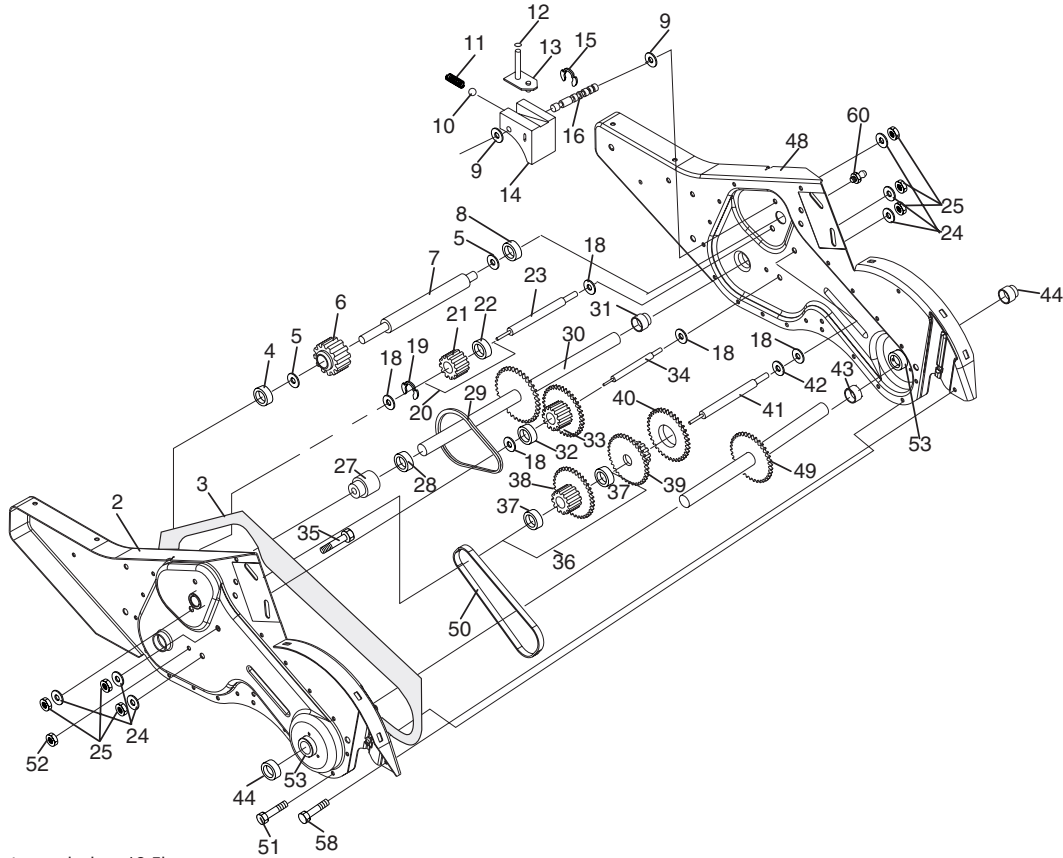

transmission_19.5b

KEY NO.	PART NO.	DESCRIPTION	KEY NO.	PART NO.	DESCRIPTION
1	188554	Transmission Assembly (Includes Key Nos. 2-52)	29	102134X	Chain #35-50 Pitch
2	188482	Gearcase, L.H. w/Bearing (Includes Key No. 4)	30	150737	Ground Shaft Assembly
3	161963	Gasket, Gearcase	31	143008	Bearing, Shaft, Ground Drive R.H.
4	5020J	Bearing, Needle	32	106388X	Spacer 0.70 x 1.00 x 1.150
5	1370H	Washer, Thrust 5/8 x 1.10 x 1/32	33	102121X	Sprocket and Gear Assembly
6	137335	Pinion, Input	34	102112X	Shaft, Reduction (2nd)
7	145101	Shaft, Input	35	102101X	Screw, Whiz, Lock 5/16-18 x 3-1/2
8	4895H	Bearing, Needle	36	154355	Sprocket Assembly w/Bearing (Includes Key Nos. 37 and 38)
9	154467	Washer, Seal	37	4422J	Bearing, Needle
10	7392M	Ball, Steel	38	154356	Sprocket, Tine
11	100371K	Spring, Shift, Fork	39	105345X	Gear, Cluster, Red 1st & 2nd
12	106160X	O-Ring	40	105346X	Gear, Reverse
13	142145	Arm, Shift	41	8358J	Shaft, Reduction (1st)
14	8353J	Fork, Shift	42	4220R	Washer, Thrust
15	12000039	Ring, Klip	43	106146X	Spacer 1.01 x 1.75 x 0.760
16	154466	Shaft, Shift	44	155236	Seal, Oil
18	4358J	Washer	48	188485	Gearcase, R.H. w/Bearing (Includes Key No. 8)
19	12000040	Ring, Klip	49	132688	Shaft, Tine
20	102114X	Gear, Assembly, Reverse Idler (Includes Key Nos. 21 and 22)	50	106147X	Chain, Roller #50-50 Pitch
21	102115X	Gear, Reverse Idler	51	17720408	Screw 1/4-20 x 1/2
22	6803J	Bearing, Needle	52	STD541031	Nut, Hex 5/16-18
23	102111X	Shaft, Reverse Idler	53	165140	Kit, Bearing
24	STD551143	Washer, Lock 7/16	58	179520	Bolt Shoulder
25	STD541143	Nut, Hex 7/16-20	60	183226	Fitting Grease
27	143009	Bearing, Shaft, Ground Drive L.H.	--	6066J	Grease, Plastilube #1
28	106390X	Spacer 0.765 x 1.125 x 1.23			

NOTE: All component dimensions given in U.S. inches.
1 inch = 25.4 mm

REPAIR PARTS

TILLER - - MODEL NUMBER 944.625930

TINE SHIELD

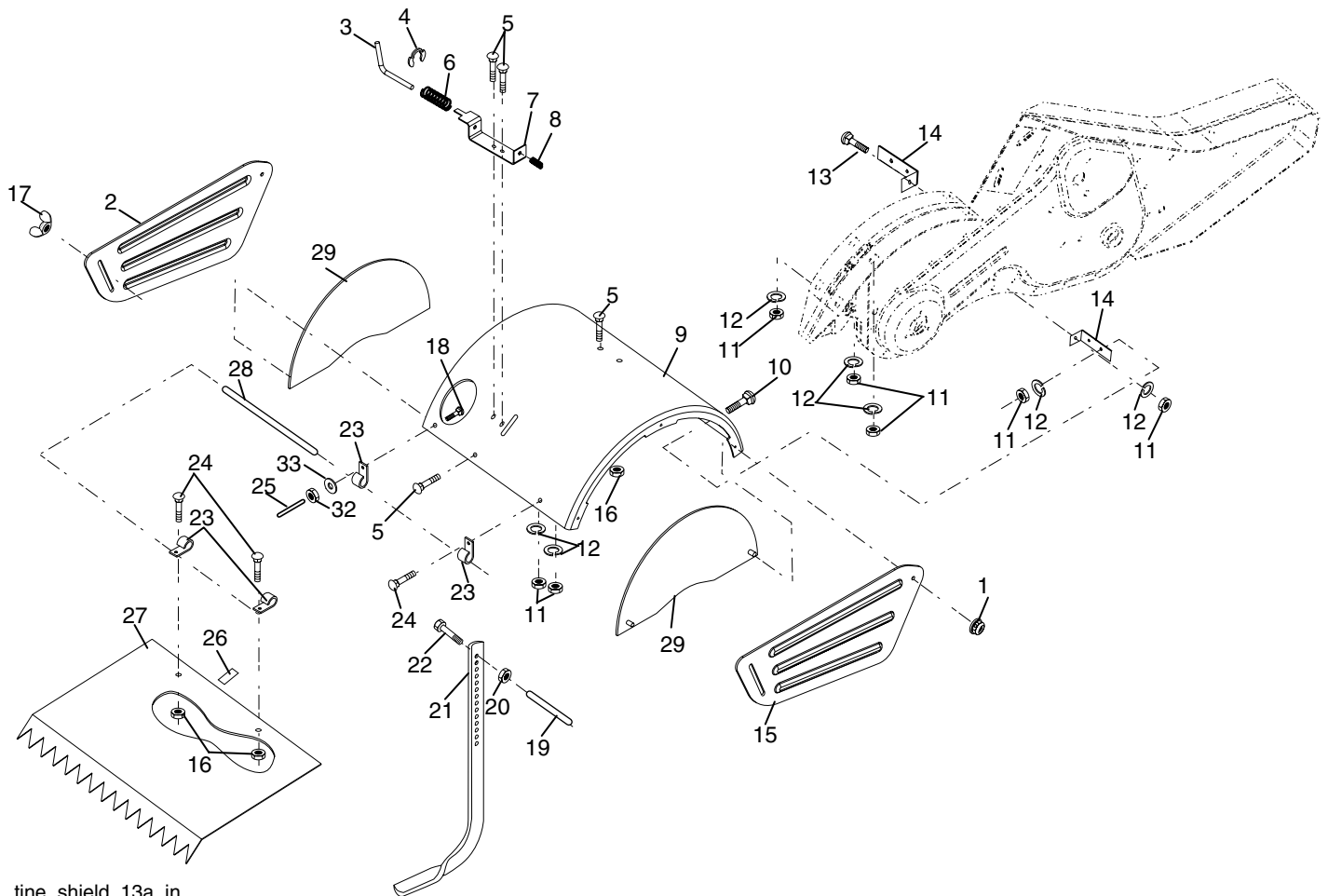

tine_shield_13a_in

KEY NO.	PART NO.	DESCRIPTION
1	73900500	Nut, Lock Flange 5/16-18 Unc
2	161415X428	Shield, Side, Outer L. H.
3	8393J	Pin, Stake, Depth
4	12000035	Ring, Klip
5	180847	Bolt, Carriage 5/16-18 x 3/4
6	8394J	Spring
7	8392J	Bracket, Latch
8	109230X	Spring, Depth Stake
9	102326X428	Shield, Tine
10	STD533110	Bolt, Carriage 5/16-18 x 1
11	STD541031	Nut, Hex 5/16-18
12	STD551131	Washer, Lock 5/16
13	STD533112	Bolt, Carriage 5/16-18 x 1-1/4
14	124343X	Bracket, Shield Tine
15	161414X428	Shield, Side, Outer R.H.
16	73900400	Nut, Flangelock 1/4-20
17	162175	Nut, Wing

KEY NO.	PART NO.	DESCRIPTION
18	STD532512	Bolt, Carriage 1/4-20 x 1-1/4 Gr. 5
19	102701X	Grip
20	STD541037	Nut, Hex 3/8-16
21	102156X	Stake, Depth
22	74930632	Bolt, Hex 3/8-16 x 2
23	4440J	Hinge
24	STD532505	Bolt, Carriage 1/4-20 x 1/2
25	6712J	Cap, Vinyl
26	109227X	Pad, Idler
27	102695X428	Shield, Leveling
28	120588X	Pin, Hinge
29	104085X428	Shield, Side
32	73220400	Nut Fin Hex 1/4-20 Unc
33	STD551125	Washer Lock Hvy Hel 1/4

NOTE: All component dimensions given in U.S. inches.
1 inch = 25.4 mm

REPAIR PARTS

TILLER - - MODEL NUMBER 944.625930

TINE ASSEMBLY

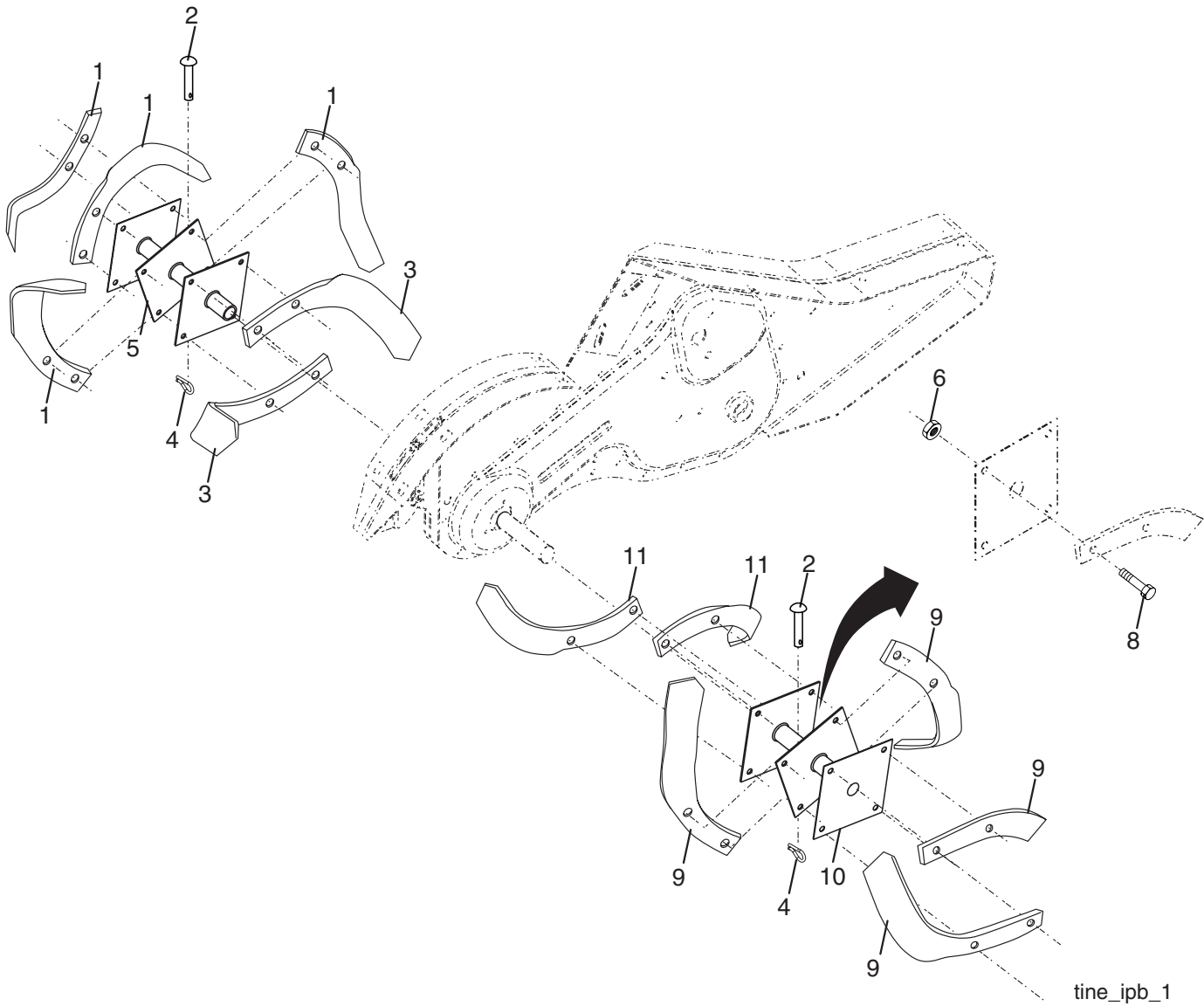

KEY NO.	PART NO.	DESCRIPTION
1	4459J	Tine LH
2	132673	Pin, Shear
3	6554J	Tine LH
4	3146R	Retainer Spring
5	132727	Hub Asm. LH 17"
6	73540600	Nut, Crownlock 3/8-24

KEY NO.	PART NO.	DESCRIPTION
8	74610616	Bolt Hex Hd 3/8-24 x 1
9	4460J	Tine RH
10	132728	Hub Asm. RH 17"
11	6555J	Tine RH

NOTE: All component dimensions given in U.S. inches.
1 inch = 25.4 mm

REPAIR PARTS

TILLER - - MODEL NUMBER 944.625930

DECALS

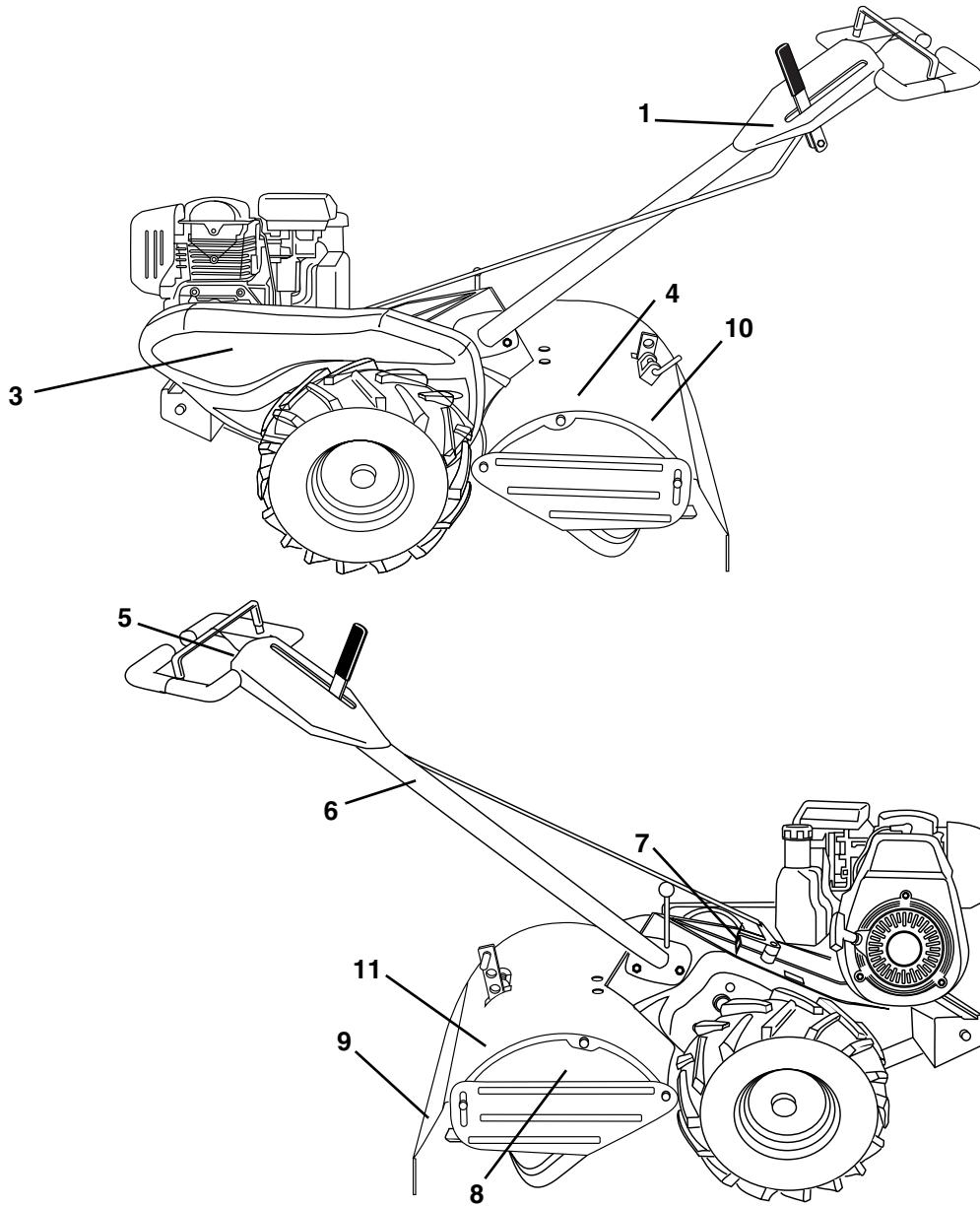

KEY NO.	PART NO.	DESCRIPTION
1	189358	Decal, Logo
3	196534	Decal, Logo
4	196532	Decal, Description
5	137282	Decal, Tine Control
6	110614X	Decal, Hand Placement
7	102180X	Decal, Shift Indicator
8	157984	Decal, Cout. Rot. Tines
9	120076X	Decal, Warning, Rotating Tines
10	168260	Decal, Tine Depth Stake
11	162384	Decal, Warning, Tine Shield
--	196535	Manual, Owner's (English)
--	196536	Manual, Owner's (French)

REPAIR PARTS

TILLER - - MODEL NUMBER 944.625930

ENGINE, HONDA - - MODEL NUMBER GC160QHA2

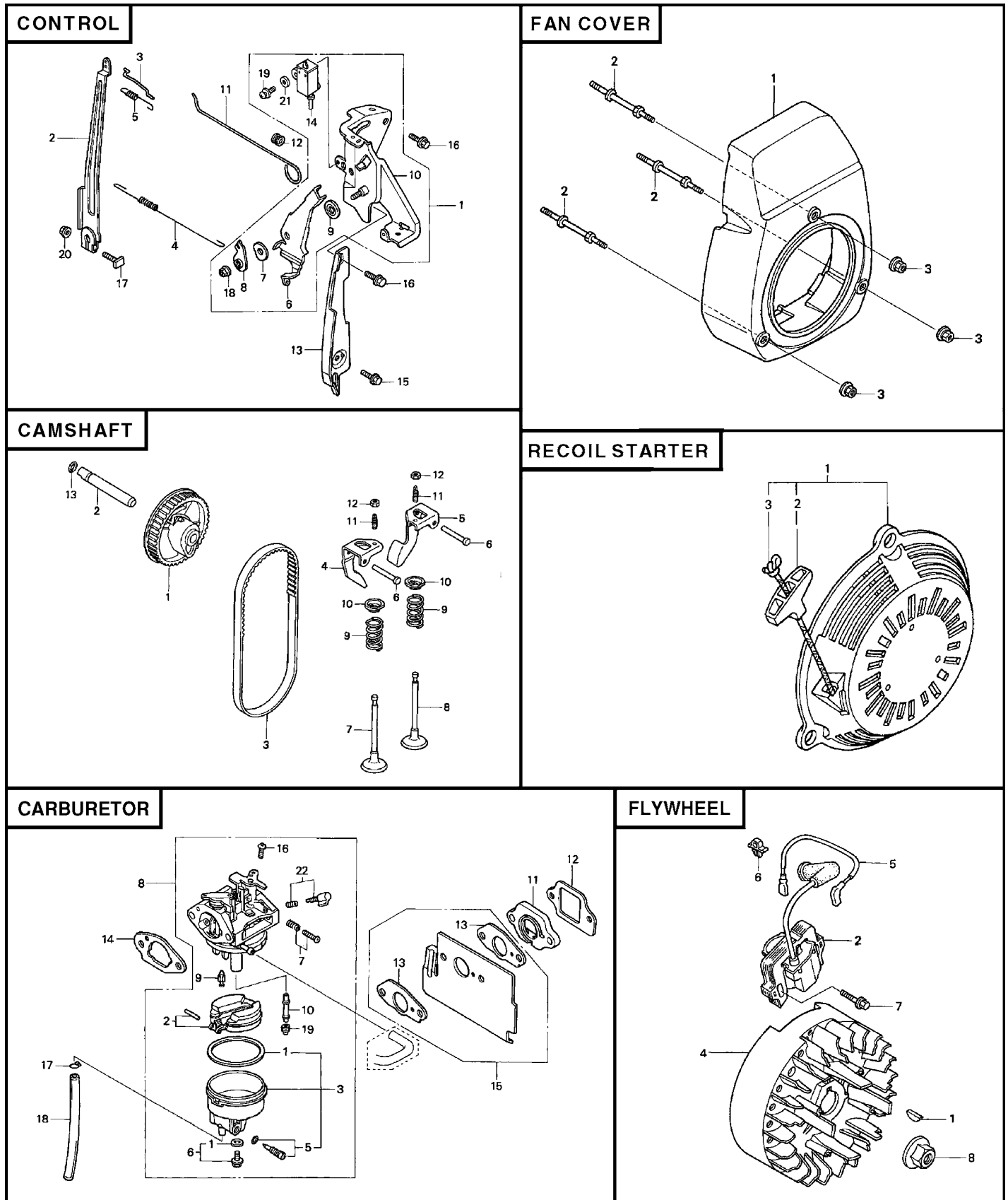

REPAIR PARTS

TILLER - - MODEL NUMBER 944.625930

ENGINE, HONDA - - MODEL NUMBER GC160QHA2

CONTROL

KEY NO.	PART NO	DESCRIPTION
1	5611074	Control assy.
2	5611132	Arm, governor
3	5611140	Rod, governor
4	5611157	Spring, governor
5	5927033	Spring, throttle return
6	5611181	Lever, control
7	1427384	Spring, lever
8	5611215	Washer, control lever
9	1427400	Spacer, control lever
10	5611256	Base, control
11	5611272	Rod, choke control
12	0788596	Grommet, choke rod
13	5656020	Plate, side
14	5611520	Switch assy., Engine stop (n.O)
15	0636845	Bolt, flange (6x12) (ct200)
16	0803619	Bolt, flange (6x14)
17	2418671	Bolt, governor arm
18	1410182	Nut, self-lock (6mm)
19	0485946	Screw-washer (4x12)
20	0471623	Nut, flange (6mm)
21	1510361	Washer, plain (4mm)

FAN COVER

KEY NO.	PART NO	DESCRIPTION
1	5611413	Cover, fan *nh1* (black)
2	5581004	Bolt, stud
3	6478812	Nut, flange (6mm)

CAMSHAFT

KEY NO.	PART NO	DESCRIPTION
1	7049679	Pulley, camshaft
2	5580063	Shaft, cam pulley
3	7058985	Belt, timing (84hu7 g-200)
4	5580089	Arm, in. Valve rocker
5	5580097	Arm, ex. Valve rocker
6	5580105	Shaft, rocker arm
7	5580113	Valve, in.
8	5580121	Valve, ex.
9	5580139	Spring, valve
10	1426980	Retainer, in. Valve spring
11	0294819	Screw, tappet adj.
12	0004598	Nut, tappet adj.
13	6315873	O-ring (6.8X1.9)

RECOIL STARTER

KEY NO.	PART NO	DESCRIPTION
1	6061204	Starter assy., Recoil *nh1* (black)
2	5580634	Knob, recoil starter
3	5611454	Rope, recoil starter (#3.5X52")

CARBURETOR

KEY NO.	PART NO	DESCRIPTION
1	3088416	Gasket set
2	5580162	Float set
3	5611033	Chamber set, float
5	0640052	Screw set, drain
6	1441518	Screw set b
7	5580170	Screw set
8	5875687	Carburetor assy. (Bb61b c)
9	5611058	Valve, float.
10	5611066	Nozzle, main
11	5580238	Insulator, carburetor
12	5580246	Gasket, insulator
13	4581120	Gasket, carburetor
14	5580253	Gasket, carburetor (choke side)
15	5611421	Guide, air
16	0639419	Screw, pan (5x6)
17	0315705	Clip, tube (b6.5)
18	4750725	Bulk hose, vinyl (4x7x8000)
19	0635474	Jet, main (#60)Optional
--	0635482	Jet, main (#62)Optional
--	0636126	Jet, main (#65)Optional
22	4481818	Screw set

FLYWHEEL - IGNITION COIL

KEY NO.	PART NO	DESCRIPTION
1	0348433	Key, special woodruff (25x18)
2	6859722	Coil assy., Ignition
4	5656053	Flywheel
5	5611504	Wire, stop switch
6	1429141	Holder, stop switch wire
7	0671552	Bolt, flange (6x20) (ct200)
8	0442038	Nut, special (14mm)

REPAIR PARTS

TILLER - - MODEL NUMBER 944.625930

ENGINE, HONDA - - MODEL NUMBER GC160QHA2

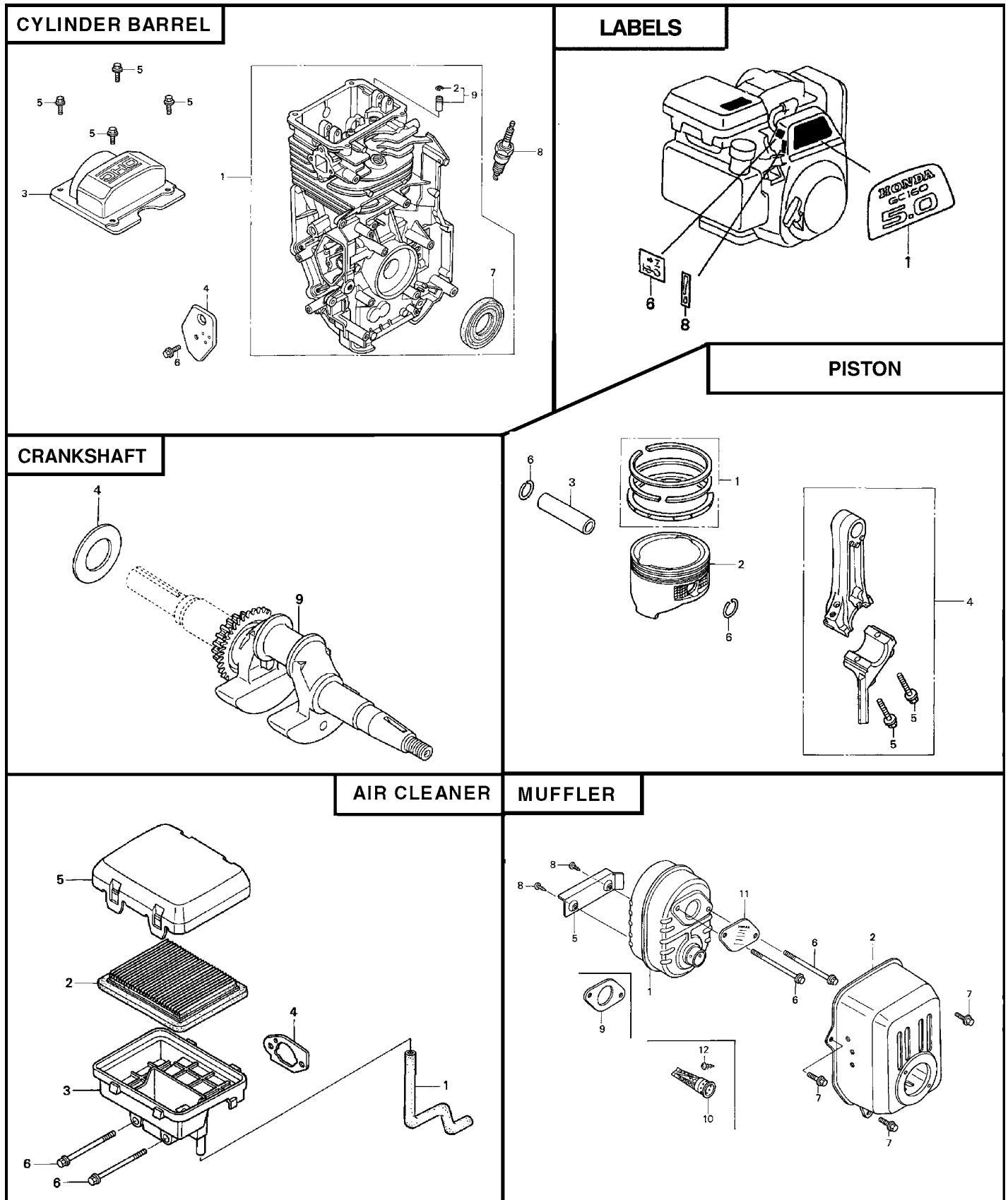

REPAIR PARTS

TILLER - - MODEL NUMBER 944.625930

ENGINE, HONDA - - MODEL NUMBER GC160QHA2

CYLINDER BARREL

KEY NO.	PART NO	DESCRIPTION
1	6842413	Cylinder assy. (010)
2	2399780	Clip, valve guide
3	6325211	Cover, head
4	5580006	Cover, breather(Breather valve assy.)
5	0636845	Bolt, flange (6x12) (ct200)
6	0803619	Bolt, flange (6x14)
7	5581038	Oil seal (25.4X62x6).
8	1441112	Spark plug (bpr6es) (ngk)
9	1899848	Guide, ex. Valve (os)

LABELS

KEY NO.	PART NO	DESCRIPTION
1	5611611	Mark, emblem (5.0)
6	5611637	Mark, choke
8	5656160	Mark, throttle indication

CRANKSHAFT

KEY NO.	PART NO	DESCRIPTION
4	5581012	Washer, thrust
9	5610985	Crankshaft (q-type)

PISTON

KEY NO.	PART NO	DESCRIPTION
1	5655949	Ring set, piston (riken)
--	6315717	Ring set, piston (teikoku)
2	5580014	Piston
3	1426576	Pin, piston
4	5580022	Rod assy.,
5	1431055	Bolt, connecting rod
6	1431055	Clip, piston pin (13mm)

AIR CLEANER

KEY NO.	PART NO	DESCRIPTION
1	5611025	Tube, breather
2	6718159	Element, air cleaner
3	5611314	Housing, air cleaner
4	5580436	Gasket, air cleaner
5	7498041	Cover, air cleaner
6	5611660	Bolt, flange (6x112) (ct200)

MUFFLER

KEY NO.	PART NO	DESCRIPTION
1	5611389	Muffler
2	5580501	Protector, muffler
5	5611439	Shroud, muffler
6	5580972	Bolt, flange (6x79) (ct200)
7	0636845	Bolt, flange (6x12) (ct200)
8	1431121	Screw, tapping (4x6)
9	5737457	Gasket, muffler
10	5656012	Arrester, Spark
11	5611397	Plate, Arrester Number
12	1431121	Screw, Tapping (4x6)

REPAIR PARTS

TILLER - - MODEL NUMBER 944.625930

ENGINE, HONDA - - MODEL NUMBER GC160QHA2

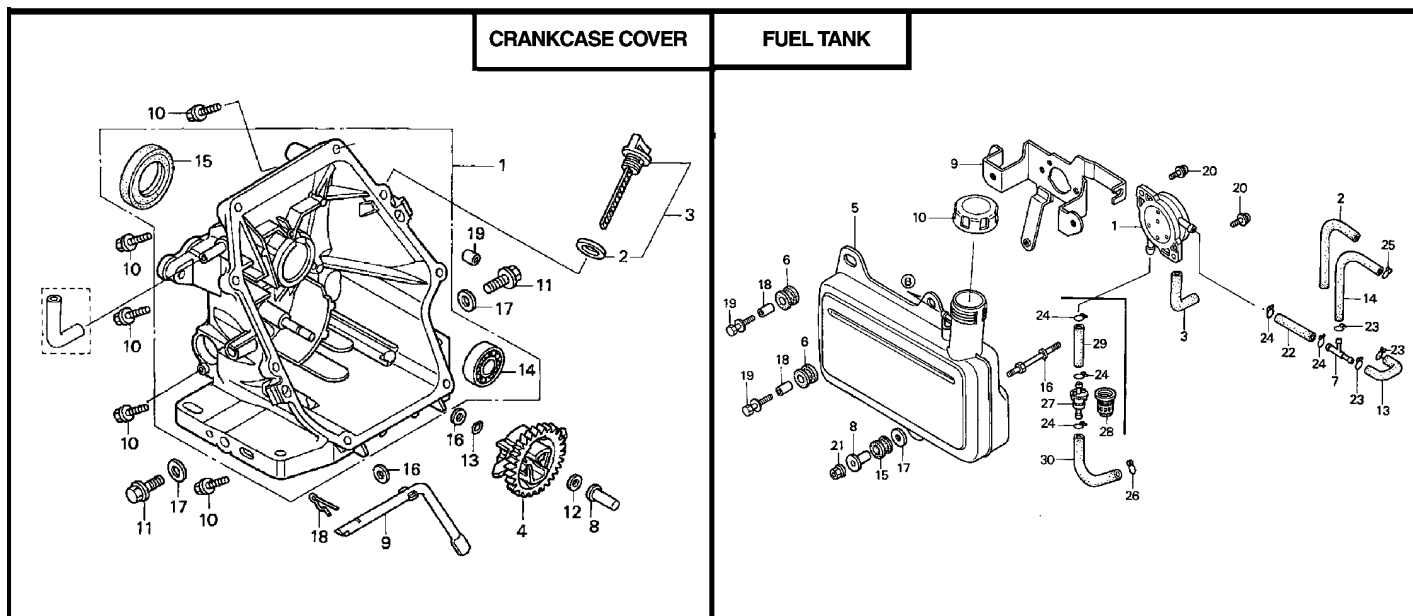

CRANKCASE COVER

KEY NO.	PART NO	DESCRIPTION
1	6262422	Cover assy., Crankcase
2	4497947	Gasket, oil filler cap
3	7310998	Gauge assy., Oil level
4	5611108	Governor assy.
8	1427251	Slider, governor
9	5611124	Shaft, governor arm
10	0748111	Bolt, flange (6x25)
12	2413862	Washer, thrust (6mm)
13	2456697	Clip, governor holder
15	5581046	Oil seal (28x41.25X6)
16	0345900	Washer, plain (6mm)
18	0115527	Pin, lock (8mm)
19	1417369	Pin, dowel (8x20)

FUEL TANK

KEY NO.	PART NO	DESCRIPTION
1	7378482	Pump assy., Fuel
2	3683646	Rubber, supporter (107mm)
3	5611306	Tube, diaphragm
5	5655972	Tank, fuel
6	1814698	Rubber b, tank mounting
7	5655980	Joint, fuel tube
8	1762962	Collar, fuel tank setting
9	5611355	Stay a, fuel tank
10	6673289	Cap assy., Fuel tank
13	5655998	Tube, fuel
14	5656004	Tube, fuel return
15	1490408	Rubber, rr. Fender
16	5611686	Bolt, stud (f/tank)
17	1033497	Washer (8mm)
18	5611702	Collar (14x6.1)
19	3473428	Bolt-washer (6x25)
20	5611736	Screw-washer (5x14)
21	0471623	Nut, flange (6mm)
22	4260352	Bulk hose, fuel (5.5X8000)
23	0250647	Clip, tube (b8)
24	0250985	Clip, tube (b10)
25	0053447	Clip, tube (c9)
26	0053595	Clip, tube (c11)
27	4432233	Filter, fuel
28	2795284	Suspension, strainer
29	5813951	Tube, fuel tank
30	5813969	Tube, fuel pump

SERVICE NOTES

Get it fixed, at your home or ours!

Just Call:

1-800-4-MY-HOME[®]

(1-800-469-4663)

24 hours a day, 7 days a week

For the repair of major brand appliances **in your own home...**
no matter who made it, no matter who sold it!

For your nearest **Sears Parts and Service** location,
to bring in products like vacuums, lawn equipment and electronics.

For **Sears Parts & Service**, to order the replacement parts,
accessories and owner's manuals that you need to do-it-yourself.

www.sears.ca

To purchase or inquire about a Sears Maintenance Agreement, call:

1-800-361-6665

9 a.m. – 11 p.m. Mon. – Fri., EST, 9 a.m. – 4 p.m. Sat.

Pour service en français:

1-800-LE-FOYER^{MC}

(1-800-533-6937)

www.sears.ca



02488

® / TM Trademarks of Sears, Roebuck and Co. used under license by Sears Canada

^{MD} Marque déposée / ^{MC} Marque de commerce de Sears, Roebuck and Co. utilisée en vertu d'une licence de Sears Canada